

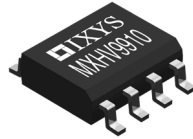

**THE DATASHEET OF
MXHV9910DB3**





Features

- 8V_{DC} to 450V_{DC} Input Voltage Range
- >90% Efficiency
- Drives Multiple LEDs in Series/Parallel Combinations
- Regulated LED Drive Current
- Linear or PWM Brightness Control
- Resistor-Programmable Oscillator Frequency
- RoHS Compliant

Applications

- Flat-Panel Display RGB Backlighting
- Signage and Decorative LED Lighting
- DC/DC or AC/DC LED Driver Applications



Description

The MXHV9910 is a low-cost, high-brightness (HB) LED driver manufactured using IXYS IC Division's high-voltage BCDMOS on SOI process. This driver has internal circuitry that allows it to operate from a universal AC line or from 8V_{DC} to 450V_{DC}. This highly versatile input operating voltage enables this IC to be used in a broad range of HB LED applications.

The driver features a fixed-frequency, peak-current control method, which provides an ideal solution for driving multiple LEDs in series and in parallel. In addition, LED dimming can be implemented by applying a small DC voltage to the LD pin, or by applying a low-frequency digital PWM signal to the PWMD pin.

The MXHV9910 is available in a standard 8-lead SOIC package and a thermally enhanced 8-lead SOIC package with an Exposed Thermal Pad (EP)

Ordering Information

Part	Description
MXHV9910B	SOIC-8 (100/Tube)
MXHV9910BTR	SOIC-8 Tape & Reel (2000/Reel)
MXHV9910BE	SOIC-8 EP (100/Tube) With Exposed Thermal Pad
MXHV9910BETR	SOIC-8 EP Tape & Reel (2000/Reel) With Exposed Thermal Pad

MXHV9910 Block Diagram

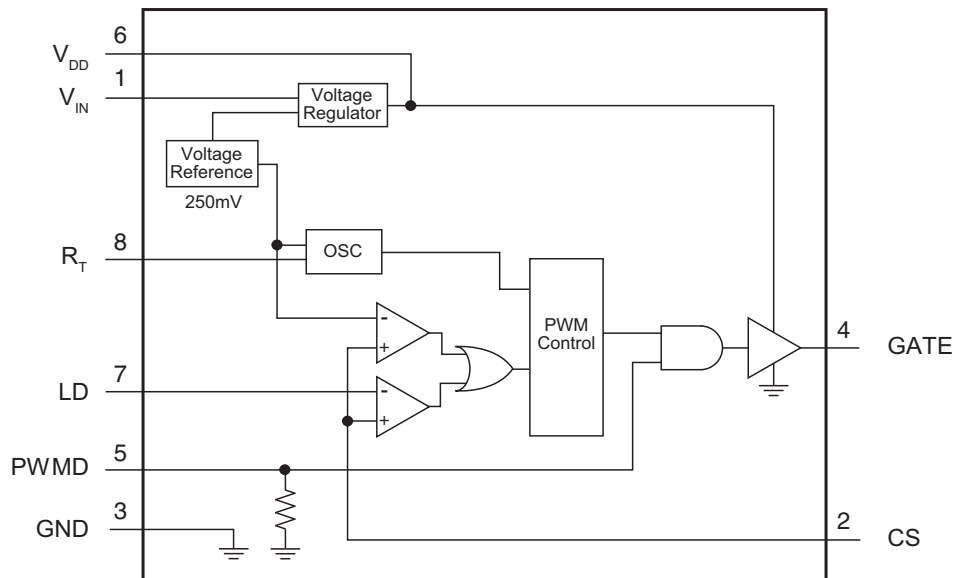

1	Specifications	3
1.1	Package Pinout	3
1.2	Pin Description	3
1.3	Absolute Maximum Ratings	3
1.4	Recommended Operating Conditions	4
1.5	Electrical Characteristics	4
1.6	Thermal Characteristics	4
2	Functional Description	5
2.1	Overview	5
2.2	LED Driver Theory of Operation	5
2.2.1	Input Voltage Regulator	6
2.2.2	Current Sense Resistor	6
2.2.3	Current Sense Blanking	7
2.2.4	Enable/Disable	7
2.2.5	Oscillator	7
2.2.6	Inductor Design	7
2.2.7	Gate Output Drive	8
2.2.8	Linear Dimming	8
2.2.9	PWM Dimming	8
2.2.10	Combination Linear and PWM Dimming	9
3	Manufacturing Information	10
3.1	Moisture Sensitivity	10
3.2	ESD Sensitivity	10
3.3	Reflow Profile	10
3.4	Board Wash	10
3.5	Mechanical Dimensions	11
3.5.1	MXHV9910B: SOIC-8	11
3.5.2	MXHV9910BE: SOIC-8 With Exposed Thermal Pad	11
3.6	Packaging Information	12
3.6.1	Tape & Reel Information for both 8-Pin Packages	12

1. Specifications

1.1 Package Pinout

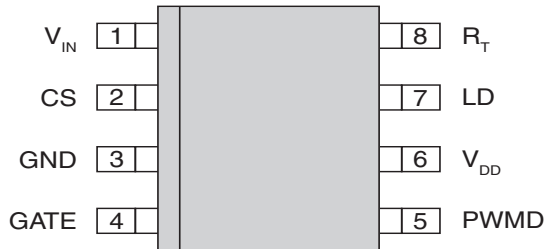

1.2 Pin Description

Pin#	Name	Description
1	V _{IN}	Input voltage
2	CS	LED Current Sense input. Internal current sense threshold is set at 250mV. The external sense resistor sets the maximum LED current.
3	GND	Device Ground
4	GATE	External MOSFET gate driver output
5	PWMD	Low-frequency PWM dimming control input with internal pull-down resistor.
6	V _{DD}	Regulated supply voltage output. Requires a storage capacitor to GND. Can be overdriven by external voltage applied to V _{DD} .
7	LD	Linear Dimming. Apply a voltage less than V _{CS(high)} to dim the LED(s).
8	R _T	Resistor to GND sets the oscillator/primary PWM frequency.
EP	-	Electrical and thermal conductive pad on the bottom of the MXHV9910BE. Connect this pad to ground, and provide sufficient thermal coupling to remove heat from the package.

1.3 Absolute Maximum Ratings

Parameter	Symbol	Maximum	Unit
Input Voltage to GND	V _{IN}	-0.5 to +460	V
Inputs & Outputs Voltage to GND	CS, LD, PWMD, GATE	-0.3 to V _{DD} +0.3	V
V _{DD} , Externally Applied	V _{DD,EXT}	15	V
Power Dissipation			
SOIC-8 With Thermal Tab	P _D	2.5	W
SOIC-8 W/O Thermal Tab		0.975	W
Maximum Junction Temperature	T _{Jmax}	150	°C
Operating Temperature	T _A	-40 to +85	°C
Junction Temperature (Operating)	T _J	-40 to +150	°C
Storage Temperature	T _{STG}	-55 to +150	°C

Electrical absolute maximum ratings are at 25°C.

Absolute maximum ratings are stress ratings. Stresses in excess of these ratings can cause permanent damage to the device. Functional operation of the device at conditions beyond those indicated in the operational sections of this data sheet is not implied.

1.4 Recommended Operating Conditions

Parameter	Symbol	Minimum	Nominal	Maximum	Unit
Input Voltage Range	V_{IN}	8	-	450	V_{DC}
PWMD Frequency	f_{PWMD}	-	500	-	Hz
Operating Temperature	T_A	-40	-	+85	$^{\circ}C$

1.5 Electrical Characteristics

Unless otherwise specified, all electrical specifications are provided for $T_A=25^{\circ}C$.

Parameter	Conditions	Symbol	Minimum	Typical	Maximum	Unit
Input						
Input DC Voltage Range	DC Input Voltage	V_{IN}	8	-	450	V_{DC}
Shut-Down Mode Supply Current	PWMD to GND, $V_{IN}=15$ to 450V	I_{INSD}	-	0.3	0.6	mA
Maximum Voltage to V_{DD} Pin	External Voltage applied to V_{DD} Pin	V_{DDmax}	-	-	12	V
Regulator						
Internal Voltage Regulator	$V_{IN}=15V$ to 450V, $I_{DD(ext)}=0$, GATE Output=Open	V_{DD}	7.2	7.8	8.4	V_{DC}
V_{DD} Current Available for External Circuitry	-	$I_{DD(ext)}$	-	-	2	mA
V_{DD} Load Regulation	$V_{IN}=15V$, $I_L=1mA$	ΔV_{DD}	-	-	200	mV
PWM Dimming						
PWMD Input Low Voltage	$V_{IN}=8V$ to 450V	$V_{EN(low)}$	-	-	0.5	V
PWMD Input High Voltage	$V_{IN}=8V$ to 450V	$V_{EN(high)}$	2.4	-	-	
PWMD Pull-Down Resistance	$V_{IN}=12V$, $V_{PWMD}=V_{DD}$	R_{EN}	70	115	165	k Ω
Current Sense Comparator						
Current Sense (CS) Input Current						μA
CS Low	CS=0V	I_{IL}	-	-45	-90	
CS High	CS= V_{DD}	I_{IH}	-	0	± 15	
Current Sense Threshold Voltage	$-40^{\circ}C < T_A < 85^{\circ}C$	$V_{CS(high)}$	200	-	280	mV
Current Sense Blanking Interval	$R_T=400k\Omega$	t_{BLANK}	-	400	-	ns
Delay from CS Trip to Gate Low	$R_T=400k\Omega$	t_{DELAY}	-	300	-	ns
Oscillator						
Oscillator Frequency (Gate Driver)	$R_T=400k\Omega$	f_S	51	64	77	kHz
Gate Driver						
Gate High Output Voltage	$I_{OUT}=-10mA$	$V_{GATE(hi)}$	$V_{DD}-0.3$	-	-	V
Gate Low Output Voltage	$I_{OUT}=10mA$	$V_{GATE(lo)}$	-	0.03	0.3	
Gate Output Rise Time	$C_{GATE}=500pF$	t_{RISE}	-	16	-	ns
Gate Output Fall Time	$C_{GATE}=500pF$	t_{FALL}	-	7	-	

1.6 Thermal Characteristics

Parameter	Package	Symbol	Minimum	Typical	Maximum	Unit
Thermal Resistance, Junction-to-Ambient	SOIC-8 With Thermal Pad (BE) ¹	$R_{\theta JA}$	-	50	-	$^{\circ}C/W$
	SOIC-8 W/O Thermal Pad (B)		-	128	-	

¹ Use of a four-layer PCB can improve thermal dissipation (reference EIA/JEDEC JESD51-5).

2. Functional Description

Figure 1 Typical Application Circuit

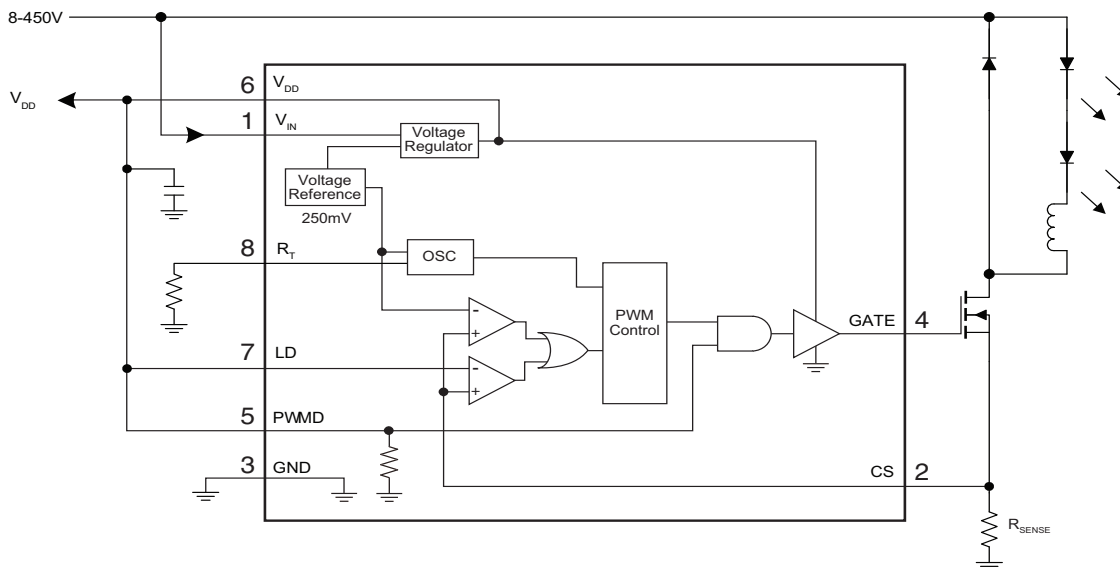

2.1 Overview

The MXHV9910 is a high-efficiency, low cost, off-line LED driver designed using IXYS IC Division's state of the art BCDMOS on SOI process. The driver can operate from a DC supply voltage between 8 to 450V_{DC}. The versatile input supply voltage range enables this driver to be used in a broad range of applications such as flat panel display RGB backlighting, signage, decorative LED lighting, and incandescent lamp replacement.

The MXHV9910 IC is configured in a buck converter topology, which is a perfect choice for off-line and DC applications driving multiple LEDs in series or parallel. This method provides excellent efficiency and enables a buck switcher design using a minimum number of external components. An external current sense resistor sets the peak current to the LED string. In addition, LED dimming can be implemented by either applying a DC control voltage to the LD pin, or by applying a low frequency, pulse-width modulated digital signal to the PWMD pin (typically 500 Hz).

2.2 LED Driver Theory of Operation

The gate driver pulse width mode (PWM) control circuit is enabled by connecting the PWMD pin to the V_{DD} pin. When enabled, the rising edge of each internal clock turns on the gate driver and the external power MOSFET, causing the inductor current to ramp

up the voltage across the current sense resistor located at the CS pin. When the rising voltage at the current sense, CS, pin exceeds V_{CS(high)}, the internally set threshold, the gate drive signal goes low and turns off the external power MOSFET. Turning the power MOSFET off causes the inductor current to decay until the next rising edge of the clock, and the process repeats.

The peak current threshold is set by comparing the voltage developed across the R_{SENSE} resistor to the internal threshold, V_{CS(high)}. This default threshold can be overridden externally by applying a voltage less than V_{CS(high)} to the LD pin. The lower of these two thresholds limits the peak current in the inductor

A soft-start function can be implemented by slowly ramping up the DC voltage at the LD pin from 0mV to a level greater than 250mV. **Figure 2** shows a typical recommended soft-start circuit design.

Figure 2 Soft-Start RC Network

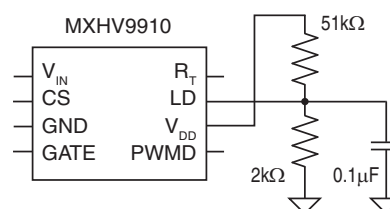
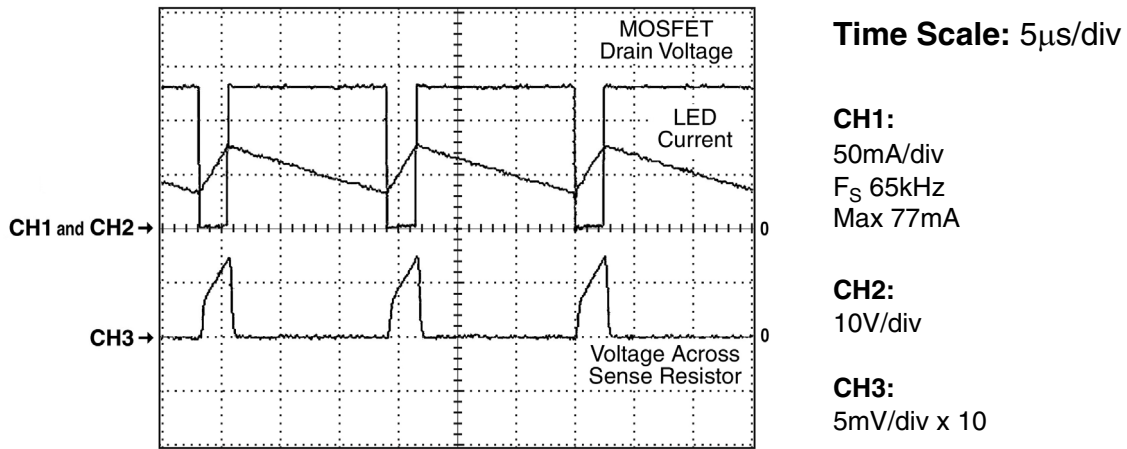

Figure 3 MXHV9910 Waveforms (From Application Circuit in Figure 6)



2.2.1 Input Voltage Regulator

The MXHV9910 has an internal voltage regulator that can work with input voltages ranging from 12V_{DC} to 450 V_{DC}. When the input voltage applied at the V_{IN} pin is greater than 12V_{DC}, the internal voltage regulator regulates this voltage down to a typical 7.8V. The V_{DD} pin is the internal regulator output pin and must be bypassed by a low ESR capacitor, typically 0.1µF, to provide a low impedance path for high frequency switching noise.

The MXHV9910 driver does not require the bulky start-up resistors typically needed for off-line controllers. An internal voltage regulator provides sufficient voltage and current to power the internal IC circuits. This voltage is also available at the V_{DD} pin, and can be used as bias voltage for external circuitry.

The internal voltage regulator can be bypassed by applying an external DC voltage to the V_{DD} pin that is slightly higher than the internal regulator’s maximum output voltage. This feature reduces power dissipation of the integrated circuit and is more suitable in isolated applications where an auxiliary transformer winding could be used to supply V_{DD}.

The total input current drawn by the V_{IN} pin is equal to the integrated circuit quiescent current, which is 0.6mA maximum, plus the gate driver current. The gate driver current is dependant on the switching frequency and the gate charge of the external power MOSFET.

The following equation can be used to approximate the V_{IN} input current:

$$I_{IN} \approx 0.6mA + (Q_{GATE} \times f_S)$$

Where Q_{GATE} is the total gate charge of the external power MOSFET, and f_S is the switching oscillator frequency.

2.2.2 Current Sense Resistor

The peak LED current is set by an external current sense resistor connected from the CS pin to ground. The value of the current sense resistor is calculated based on the desired average LED current, the current sense threshold, and the inductor ripple current.

The inductor is typically selected to be large enough to keep the ripple current (the peak-to-peak difference in the inductor current waveform) to less than 30% of the average LED current. Factoring in this ripple current requirement, the current sense resistor can be determined by:

$$R_{sense} = \frac{V_{csth}}{[1 + (0.5 \times r_{iout})] \times I_{LED}}$$

Where:

- V_{csth} = nominal current sense threshold = 0.25V
- r_{iout} = inductor ripple = 0.3
- I_{LED} = average LED current

The power dissipation rating of the sense resistor can be found with the following formula:

$$P = I_{LED}^2 \times R_{sense}$$

It is a good practice to select a power rating that is at least twice the calculated value. This will give proper margins, and make the design more reliable.

2.2.3 Current Sense Blanking

The MXHV9910 has an internal current-sense blanking circuit. When the power MOSFET is turned on, the external inductor can cause an undesired spike at the current sense pin, CS, initiating a premature termination of the gate pulse. To avoid this condition, a typical 400ns internal leading edge blanking time is implemented. This internal feature eliminates the need for external RC filtering, thus simplifying the design. During the current sense blanking time, the current limit comparator is disabled, preventing the gate-drive circuit from terminating the gate-drive signal.

2.2.4 Enable/Disable

Connecting the PWMD pin to V_{DD} enables the gate driver. Connecting PWMD to GND disables the gate driver and sets the device into the shut-down mode. In the shut-down mode, the gate output drive is disabled while all other functions remain active. The maximum quiescent current in the shut-down mode is 0.6mA.

2.2.5 Oscillator

The MXHV9910 operates in a constant frequency mode. Setting the oscillator frequency is achieved by connecting an external resistor between R_T and GND. In general, switching frequency selection is based on the inductor size, controller power dissipation, and the input filter capacitor.

The typical off-line LED driver switching frequency, f_s , is between 30kHz and 120kHz. This operating range gives designers a reasonable compromise between switching losses and inductor size. The internal RC oscillator has a frequency accuracy of $\pm 20\%$. **Figure 4** shows the R_T resistor selection for the desired f_s .

Figure 4 Resistor Selection

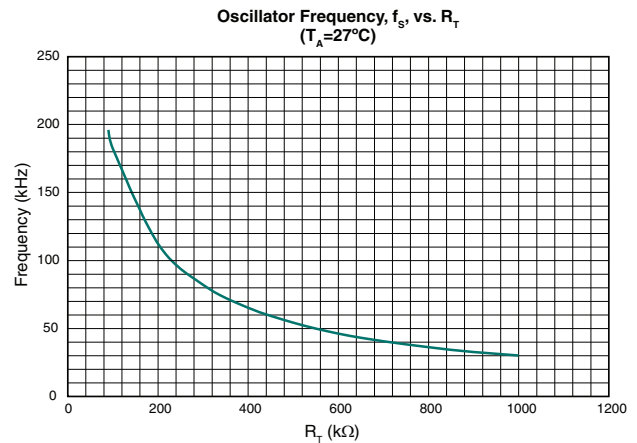

2.2.6 Inductor Design

The inductor value is determined based on LED ripple current, maximum on-time, the forward voltage drop of all LEDs in a string at the desired current, and the minimum input voltage, which is based on design requirements. The maximum on-time is determined by the duty cycle and switching frequency. The maximum duty cycle is given by:

$$D_{max} = \frac{V_{LEDstring}}{V_{in}}$$

Where:

- $V_{LEDstring}$ is the LED string voltage at desired average LED current.
- V_{in} is the minimum input voltage to V_{IN}

The maximum duty cycle must be restricted to less than 50% in order to prevent sub-harmonic oscillations and open loop instability.

The converter maximum ON-time is given by:

$$t_{ONmax} = \frac{D_{max}}{f_s}$$

Where f_s is the switching frequency of the internal oscillator.

The inductor value for the given ripple is:

$$L_{min} = \frac{(V_{in} - V_{LEDstring}) \times t_{ONmax}}{r_{iout} \times I_{LED}}$$

The inductor peak current rating is given by:

$$I_{Lmax} = I_{LED} \times [1 + (0.5 \times r_{iout})]$$

2.2.7 Gate Output Drive

The MXHV9910 uses an internal gate drive circuit to turn on and off an external power MOSFET. The gate driver can drive a variety of MOSFETs. For a typical off-line application, the total MOSFET gate charge will be less than 25nC.

2.2.8 Linear Dimming

A linear dimming function can be implemented by applying a DC control voltage to the LD pin. By varying this voltage, the user can adjust the current level in the LEDs, which in turn will increase or decrease the light intensity. The control voltage to the LD pin can be generated from an external voltage divider network from V_{DD} . This function is useful if the user requires a LED current at a particular level and there is no exact R_{sense} value available. Note that applying a voltage higher than the current sense threshold voltage at the LD pin will not change the output current due to the fixed threshold setting. When the LD pin is not used, it should be connected to V_{DD} .

Figure 5 Typical Linear Dimming Application Circuit

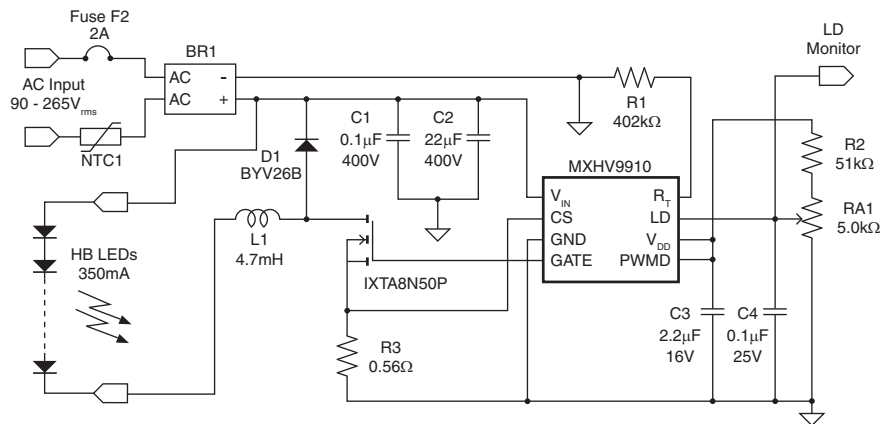

2.2.9 PWM Dimming

Pulse width modulation dimming can be implemented by driving the PWMD pin with a low frequency square wave signal in the range of a few hundred Hertz. The PWMD signal controls the LED brightness by gating the PWM gate driver output pin GATE.

The signal can be generated by a microcontroller or a pulse generator with a duty cycle proportional to the amount of desired light output. When PWMD is low, gate drive is off; when PWMD is high, gate drive is enabled.

Figure 6 Buck Driver for PWM Dimming Application Circuit

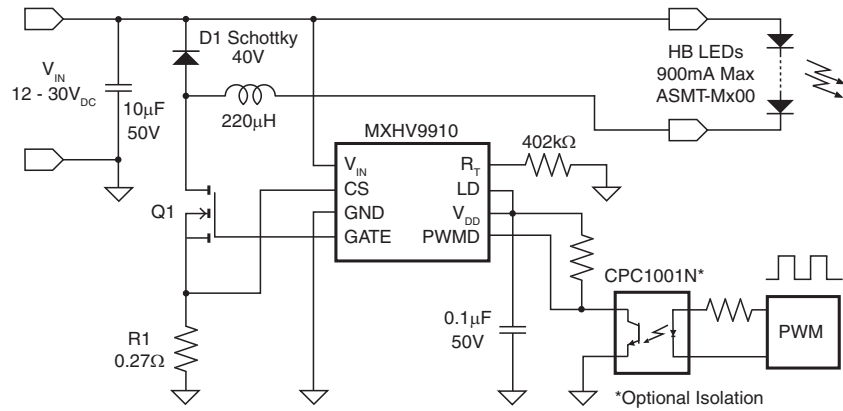

2.2.10 Combination Linear and PWM Dimming

A combination of linear and PWM dimming techniques can be used to achieve a large dimming ratio.

Note: The output current will not go to zero if the LD pin is pulled to GND because the minimum gate driver on-time is equal to the current sense blanking interval. To achieve zero LED current, the PWMD pin should be used.

3. Manufacturing Information

3.1 Moisture Sensitivity



All plastic encapsulated semiconductor packages are susceptible to moisture ingress. IXYS Integrated Circuits Division classified all of its plastic encapsulated devices for moisture sensitivity according to the latest version of the joint industry standard, **IPC/JEDEC J-STD-020**, in force at the time of product evaluation. We test all of our products to the maximum conditions set forth in the standard, and guarantee proper operation of our devices when handled according to the limitations and information in that standard as well as to any limitations set forth in the information or standards referenced below.

Failure to adhere to the warnings or limitations as established by the listed specifications could result in reduced product performance, reduction of operable life, and/or reduction of overall reliability.

This product carries a **Moisture Sensitivity Level (MSL) rating** as shown below, and should be handled according to the requirements of the latest version of the joint industry standard **IPC/JEDEC J-STD-033**.

Device	Moisture Sensitivity Level (MSL) Rating
MXHV9910B / MXHV9910BE	MSL 1

3.2 ESD Sensitivity



This product is **ESD Sensitive**, and should be handled according to the industry standard **JESD-625**.

3.3 Reflow Profile

This product has a maximum body temperature and time rating as shown below. All other guidelines of **J-STD-020** must be observed.

Device	Maximum Temperature x Time
MXHV9910B / MXHV9910BE	260°C for 30 seconds

3.4 Board Wash

IXYS Integrated Circuits Division recommends the use of no-clean flux formulations. However, board washing to remove flux residue is acceptable, and the use of a short drying bake may be necessary. Chlorine-based or Fluorine-based solvents or fluxes should not be used. Cleaning methods that employ ultrasonic energy should not be used.



3.6 Packaging Information

3.6.1 Tape & Reel Information for both 8-Pin Packages

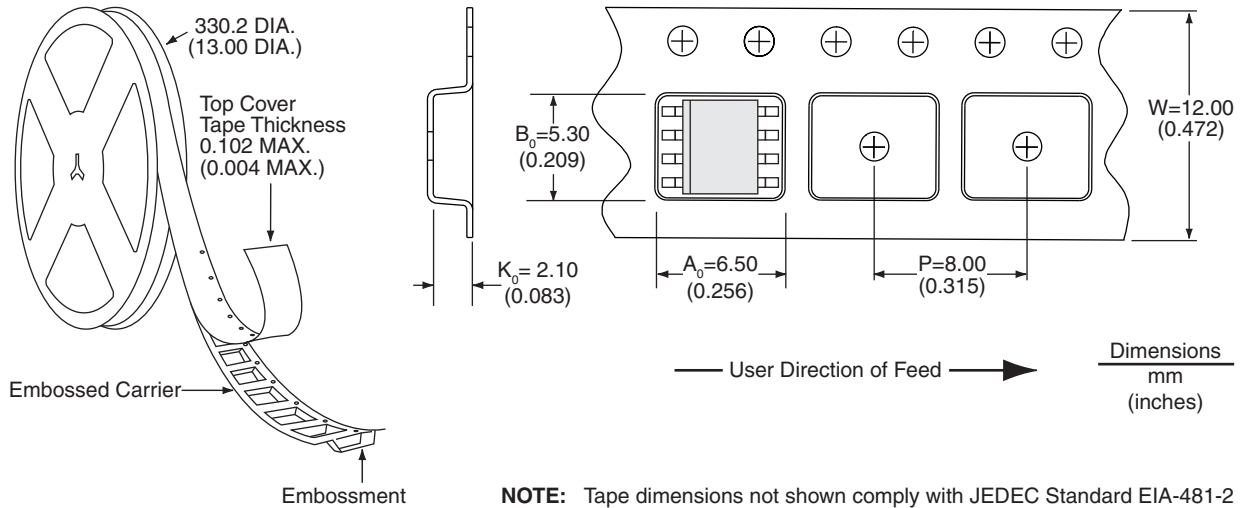

For additional information please visit www.ixysic.com

IXYS Integrated Circuits Division makes no representations or warranties with respect to the accuracy or completeness of the contents of this publication and reserves the right to make changes to specifications and product descriptions at any time without notice. Neither circuit patent licenses or indemnity are expressed or implied. Except as set forth in IXYS Integrated Circuits Division's Standard Terms and Conditions of Sale, IXYS Integrated Circuits Division assumes no liability whatsoever, and disclaims any express or implied warranty relating to its products, including, but not limited to, the implied warranty of merchantability, fitness for a particular purpose, or infringement of any intellectual property right.

The products described in this document are not designed, intended, authorized, or warranted for use as components in systems intended for surgical implant into the body, or in other applications intended to support or sustain life, or where malfunction of IXYS Integrated Circuits Division's product may result in direct physical harm, injury, or death to a person or severe property or environmental damage. IXYS Integrated Circuits Division reserves the right to discontinue or make changes to its products at any time without notice.

Specifications: DS-MXHV9910-R04
© Copyright 2014, IXYS Integrated Circuits Division
All rights reserved. Printed in USA.
6/16/2014

Looking for pricing, stock, or lifecycle information?

Click below to explore more details on WIN SOURCE:

 [View MXHV9910DB3 on WIN SOURCE](#)

 [IXYS Information](#)

Optimize Your Supply Chain with WIN SOURCE Solutions

-  Global Sourcing Solution
-  Obsolete Management
-  Cost Control Management
-  Shortage Management
-  Alternative Solution
-  Excess Inventory Management