

20-Channel Serial-Input Vacuum Fluorescent Display Driver for Anode or Grid

Features

- HVCMOS[®] Technology for High Performance
- Operating Voltage of up to 80V
- High-speed Source Driver
- 5V CMOS Logic Circuitry
- Up to 5 MHz Data Input Rate
- Excellent Noise Immunity
- Flexible High-voltage Supplies

Applications

- Display Driver

General Description

The HV5812 is a 20-channel serial-input vacuum fluorescent display driver. It combines a 20-bit CMOS shift register, data latches and control circuitry with high-voltage MOSFET outputs. The HV5812 is primarily designed for vacuum fluorescent displays.

The CMOS shift register and latches allow direct interfacing with microprocessor-based systems. Data input rates are typically over 5 MHz with 5V logic supply. Especially useful for interdigit blanking, the blanking input disables the output source drives and turns on the sink drivers. Using with TTL may require external pull-up resistors to ensure an input logic high.

Package Types

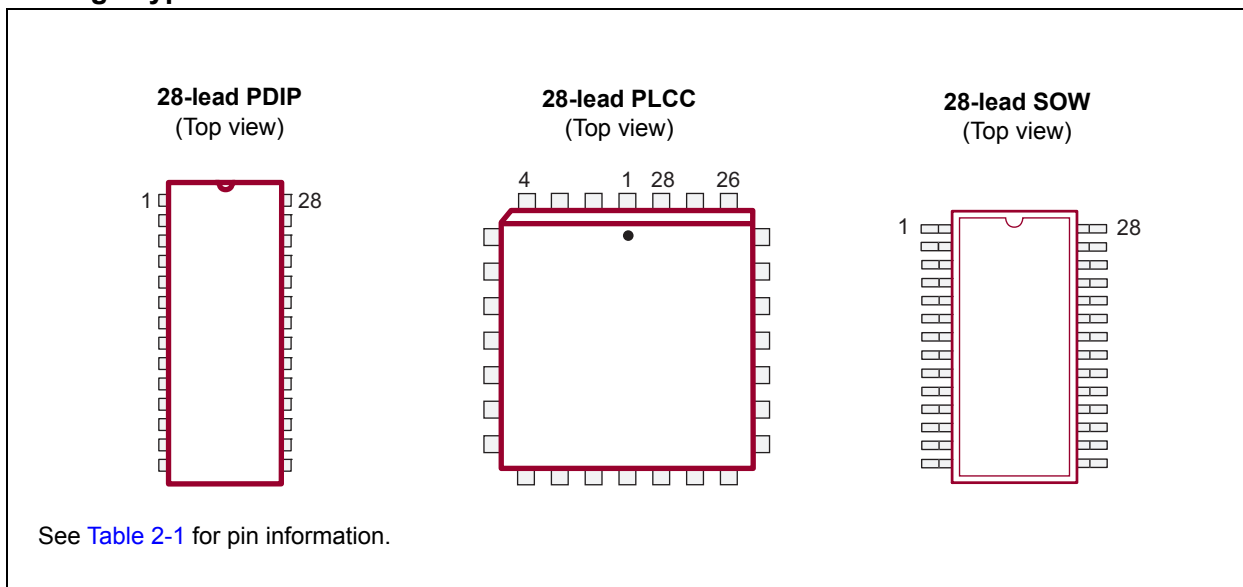

HV5812

Functional Block Diagram

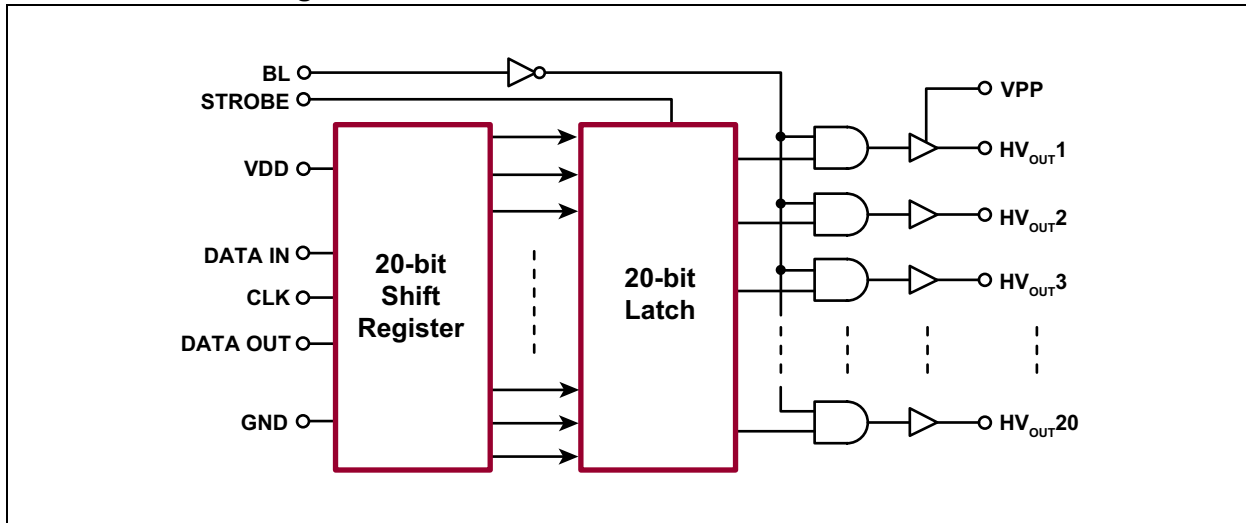

1.0 ELECTRICAL CHARACTERISTICS

Absolute Maximum Ratings†

Supply Voltage, V_{DD}	-0.5V to +7.5V
Supply Voltage, V_{PP}	-0.5V to +90V
Logic Input Levels.....	-0.3V to $V_{DD} + 0.3V$
Maximum Operating Junction Temperature.....	+125°C
Storage Temperature.....	-55°C to +150°C
Power Dissipation:	
28-lead PDIP.....	2000 mW
28-lead PLCC.....	1900 mW
28-Lead SOW.....	1700 mW

† **Notice:** Stresses above those listed under “Absolute Maximum Ratings” may cause permanent damage to the device. This is a stress rating only, and functional operation of the device at those or any other conditions above those indicated in the operational sections of this specification is not intended. Exposure to maximum rating conditions for extended periods may affect device reliability.

RECOMMENDED OPERATING CONDITIONS

Parameter	Sym.	Min.	Typ.	Max.	Unit	Conditions
Supply Voltage	V_{DD}	4.5	—	5.5	V	
Supply Voltage	V_{PP}	20	—	80	V	
Operating Junction Temperature	T_J	-40	—	+125	°C	

DC ELECTRICAL CHARACTERISTICS

Electrical Specifications: Over recommended operating conditions; $T_A = 25^\circ\text{C}$ unless otherwise indicated.

Parameter	Sym.	Min.	Typ.	Max.	Unit	Conditions	
Output Leakage Current	I_{DSS}	—	-5	-15	μA	$V_{OUT} = 0V, T_A = +70^\circ\text{C}$	
High-level Output	V_{OH}	HV_{OUT}	78	78.5	—	V	$I_{OUT} = -25\text{ mA}, V_{PP} = 80V, T_J = +25^\circ\text{C}$
		HV_{OUT}	77	78	—	V	$I_{OUT} = -25\text{ mA}, V_{PP} = 80V, T_J = +125^\circ\text{C}$
	DATA OUT	4.5	4.7	—	V	$I_{OUT} = -200\ \mu\text{A}, V_{DD} = 5V$	
Low-level Output	V_{OL}	HV_{OUT}	—	1.5	3	V	$I_{OUT} = 1\text{ mA}, T_J = +25^\circ\text{C}, V_{DD} = 5V$
		HV_{OUT}	—	2.3	4	V	$I_{OUT} = 1\text{ mA}, T_J = +125^\circ\text{C}, V_{DD} = 5V$
	DATA OUT	—	200	250	V	$I_{OUT} = +200\ \mu\text{A}, V_{DD} = 5V$	
Output Pull-down Current	I_{SINK}	2	3.5	—	mA	$V_{OUT} = 5V\text{ to }V_{PP}, V_{DD} = 5V$	
High-level Logic Input Voltage	V_{IH}	3.5	—	5.3	V	$V_{DD} = 5V$	
Low-level Logic Input Voltage	V_{IL}	-0.3	—	0.8	V		
High-level Logic Input Current	I_{IH}	—	0.05	0.5	μA	$V_{IN} = V_{DD}, V_{DD} = 5V$	
Low-level Logic Input Current	I_{IL}	—	-0.05	-0.5	μA	$V_{IN} = 0.8V, V_{DD} = 5V$	
Quiescent V_{DD} Supply Current	I_{DDQ}	—	100	300	μA	All outputs high, $V_{DD} = 5V$	
		—	100	300	μA	All outputs low, $V_{DD} = 5V$	
Quiescent V_{PP} Supply Current	I_{PPQ}	—	10	100	μA	All outputs high, no load	
		—	10	100	μA	All outputs low, no load	

HV5812

AC ELECTRICAL CHARACTERISTICS

Electrical Specifications: Over recommended operating conditions; $T_A = 25^\circ\text{C}$ unless otherwise indicated.						
Parameter	Sym.	Min.	Typ.	Max.	Unit	Conditions
Blanking to Output Delay	t_{PHL}	—	2000	—	ns	$C_L = 30 \text{ pF}$, 50% to 50%, $V_{\text{DD}}=5\text{V}$
	t_{PLH}	—	1000	—		
Output Fall Time	t_f	—	1450	—	ns	$C_L = 30 \text{ pF}$, 90% to 10%, $V_{\text{DD}} = 5\text{V}$
Output Rise Time	t_r	—	650	—	ns	$C_L = 30 \text{ pF}$, 10% to 90%, $V_{\text{DD}} = 5\text{V}$
Data Set-up Time	t_{SU}	75	—	—	ns	See Timing Waveforms .
Data Hold Time	t_{H}	75	—	—	ns	See Timing Waveforms .
Minimum Data Pulse Width	t_{PWD}	150	—	—	ns	See Timing Waveforms .
Minimum Clock Pulse Width	t_{PWCLK}	150	—	—	ns	See Timing Waveforms .
Minimum Time between Clock Activation and Strobe	t_{CKS}	300	—	—	ns	See Timing Waveforms .
Minimum Strobe Pulse Width	t_{PWS}	100	—	—	ns	See Timing Waveforms .
Typical Time between Strobe Activation and Output Transition	t_{STO}	—	500	—	ns	See Timing Waveforms .
Maximum Clock Frequency	f_{CLK}	—	8	—	MHz	$T_J = +25^\circ\text{C}$, $V_{\text{DD}} = 5\text{V}$
		—	5	—		$T_J = +125^\circ\text{C}$, $V_{\text{DD}} = 5\text{V}$

TEMPERATURE SPECIFICATIONS

Parameter	Sym.	Min.	Typ.	Max.	Unit	Conditions
TEMPERATURE RANGE						
Operating Junction Temperature	T_J	-40	—	+125	$^\circ\text{C}$	
Storage Temperature	T_S	-55	—	+150	$^\circ\text{C}$	
PACKAGE THERMAL RESISTANCE						
28-lead PDIP	θ_{JA}	—	43	—	$^\circ\text{C/W}$	
28-lead PLCC	θ_{JA}	—	48	—	$^\circ\text{C/W}$	
28-lead SOW	θ_{JA}	—	55	—	$^\circ\text{C/W}$	

Timing Waveforms

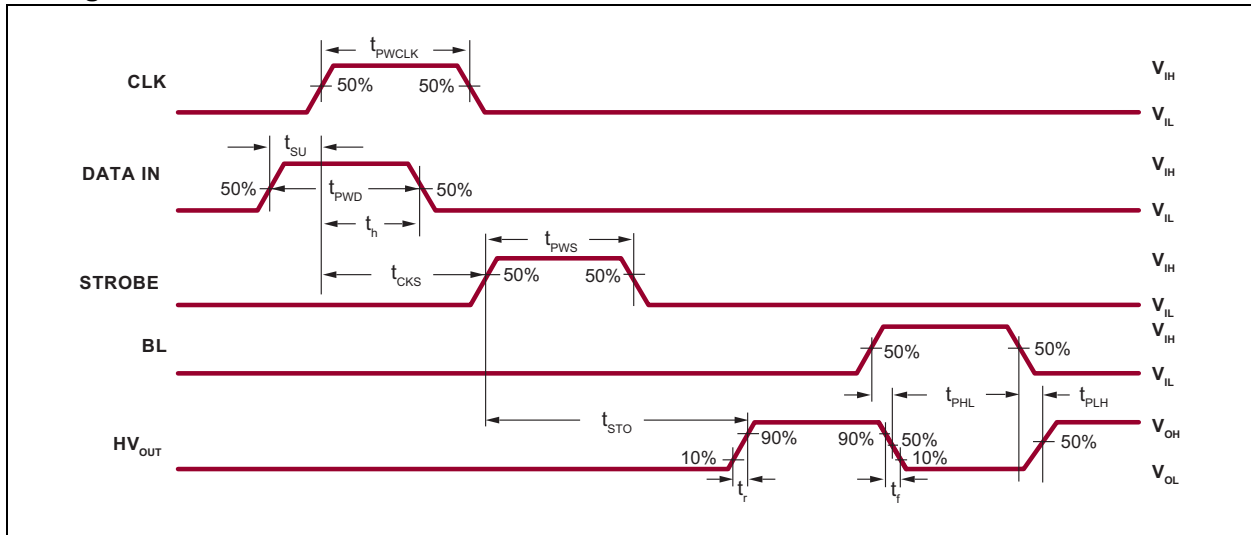

HV5812

2.0 PIN DESCRIPTION

The details on the pins of HV5812 28-lead PDIP, 28-lead PLCC and 28-lead SOW are listed on [Table 2-1](#). Refer to [Package Types](#) for the location of pins.

TABLE 2-1: PIN FUNCTION TABLE

Pin Number	Pin Name	Description
1	VPP	High-voltage power rail
2	Data Out	Serial data output. Data output for cascading to the data input of the next device.
3	HV _{OUT} 20	High-voltage output
4	HV _{OUT} 19	High-voltage output
5	HV _{OUT} 18	High-voltage output
6	HV _{OUT} 17	High-voltage output
7	HV _{OUT} 16	High-voltage output
8	HV _{OUT} 15	High-voltage output
9	HV _{OUT} 14	High-voltage output
10	HV _{OUT} 13	High-voltage output
11	HV _{OUT} 12	High-voltage output
12	HV _{OUT} 11	High-voltage output
13	BLANKING	Blank
14	GND	Logic and high-voltage ground
15	CLOCK	Data shift register clock
16	STROBE	Strobe
17	HV _{OUT} 10	High-voltage output
18	HV _{OUT} 9	High-voltage output
19	HV _{OUT} 8	High-voltage output
20	HV _{OUT} 7	High-voltage output
21	HV _{OUT} 6	High-voltage output
22	HV _{OUT} 5	High-voltage output
23	HV _{OUT} 4	High-voltage output
24	HV _{OUT} 3	High-voltage output
25	HV _{OUT} 2	High-voltage output
26	HV _{OUT} 1	High-voltage output
27	Data In	Serial data input
28	VDD	Low-voltage logic power rail

3.0 FUNCTIONAL DESCRIPTION

Follow the steps below to power up and power down the HV5812:

POWER-UP AND POWER-DOWN SEQUENCE

Power-up		Power-down	
Step	Description	Step	Description
1	Connect ground.	1	Remove V_{PP} .
2	Apply V_{DD} .	2	Remove all inputs.
3	Set all inputs (Data, CLK, etc.) to a known state	3	Remove V_{DD} .
4	Apply V_{PP} (Note 1)	4	Disconnect ground.

Note 1: The V_{PP} should not drop below V_{DD} during operation.

FUNCTION TABLE (**Note 1**)

Serial Data Input	Clock Input	Shift Register Contents				Serial Data Output	Strobe Input	Latch Contents				Blanking	Output Contents					
		I_1	I_2	$I_3...I_{N-1}$	I_N			I_1	I_2	$I_3...I_{N-1}$	I_N		O_1	O_2	$O_3...O_{N-1}$	O_N		
H	L to H	H	R_1	$R_2...R_{N-2}$	R_{N-1}	R_{N-1}	—	—	—	—	—	—	—	—	—	—	—	—
L	L to H	L	R_1	$R_2...R_{N-2}$	R_{N-1}	R_{N-1}	—	—	—	—	—	—	—	—	—	—	—	—
X	H to L	R_1	R_2	$R_3...R_{N-1}$	R_N	R_N	—	—	—	—	—	—	—	—	—	—	—	—
—	—	X	X	$X...X$	X	X	L	R_1	R_2	$R_3...R_{N-1}$	R_N	—	—	—	—	—	—	—
—	—	P_1	P_2	$P_3...P_{N-1}$	P_N	P_N	H	P_1	P_2	$P_3...P_{N-1}$	P_N	L	P_1	P_2	$P_3...P_{N-1}$	P_N	—	—
—	—	—	—	—	—	—	—	X	X	$X...X$	X	H	L	L	$L...L$	L	—	—

Note 1: L = Low logic level
 H = High logic level
 X = Irrelevant
 P = Present state
 R = Previous state

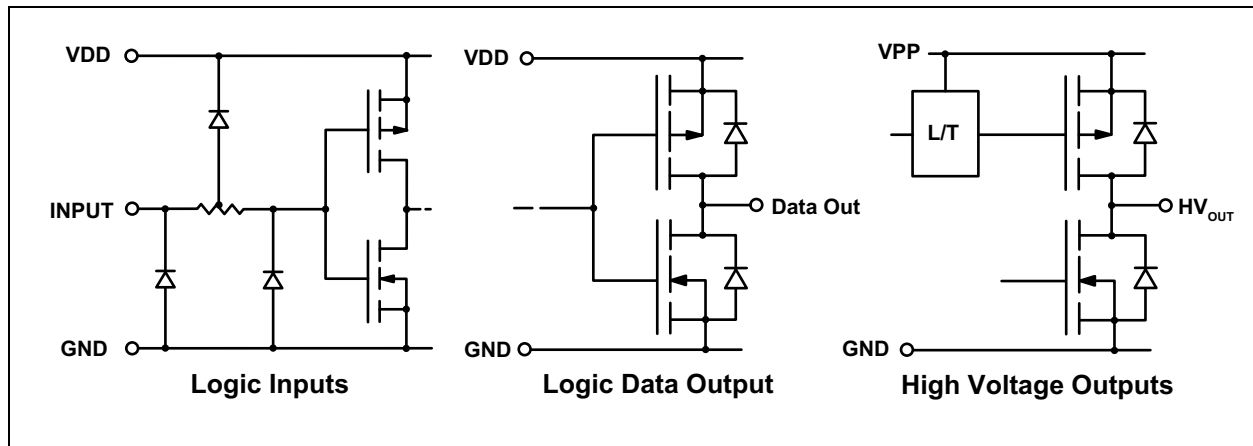

FIGURE 3-1: IO Circuits.

HV5812

4.0 PACKAGE MARKING INFORMATION

4.1 Packaging Information

28-lead PDIP



Example



28-lead PLCC

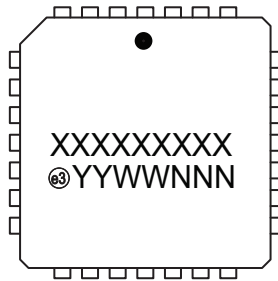

Example

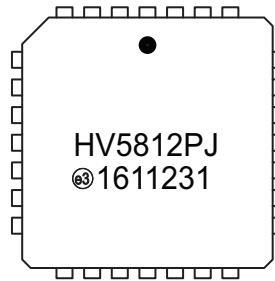

28-lead SOW



Example



Legend:	XX...X	Product Code or Customer-specific information
	Y	Year code (last digit of calendar year)
	YY	Year code (last 2 digits of calendar year)
	WW	Week code (week of January 1 is week '01')
	NNN	Alphanumeric traceability code
	ⓔ3	Pb-free JEDEC® designator for Matte Tin (Sn)
	*	This package is Pb-free. The Pb-free JEDEC designator (ⓔ3) can be found on the outer packaging for this package.

Note: In the event the full Microchip part number cannot be marked on one line, it will be carried over to the next line, thus limiting the number of available characters for product code or customer-specific information. Package may or not include the corporate logo.

28-Lead PDIP (.600in Row Spacing) Package Outline (P) 1.565x.580in body, .250in height (max), .100in pitch

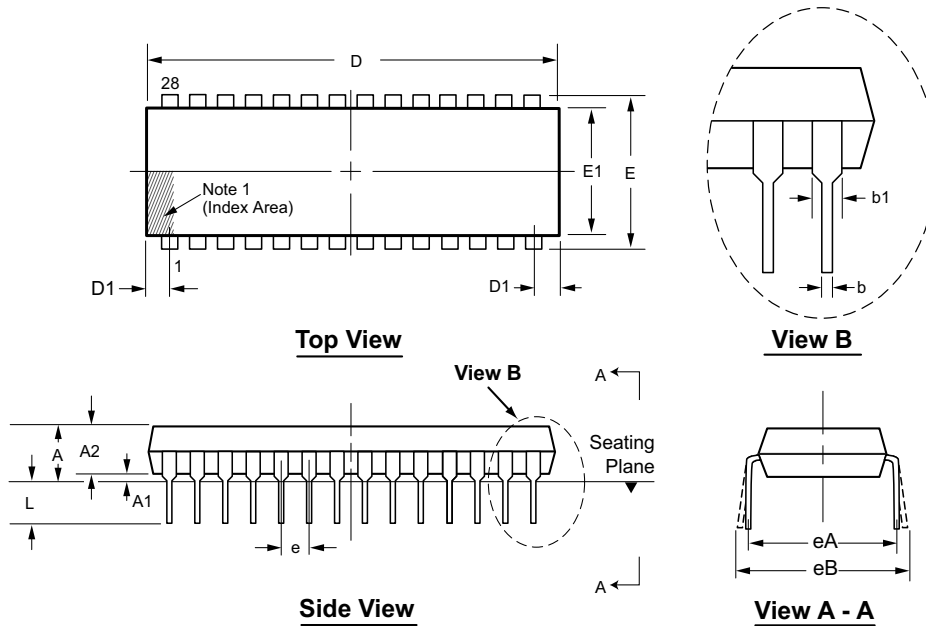

Note: For the most current package drawings, see the Microchip Packaging Specification at www.microchip.com/packaging.

Note:

1. A Pin 1 identifier must be located in the index area indicated. The Pin 1 identifier can be: a molded mark/identifier; an embedded metal marker; or a printed indicator.

Symbol	A	A1	A2	b	b1	D	D1	E	E1	e	eA	eB	L	
Dimension (inches)	MIN	.140*	.015	.125	.014	.030	1.380	.065†	.590†	.485	.100 BSC	.600 BSC	.600*	.115
	NOM	-	-	-	-	-	-	-	-	-			-	-
	MAX	.250	.055*	.195	.023†	.070	1.565	.085*	.625	.580			.700	.200

JEDEC Registration MS-011, Variation AB, Issue B, June, 1988.

* This dimension is not specified in the JEDEC drawing.

† This dimension differs from the JEDEC drawing.

Drawings not to scale.

28-Lead PLCC Package Outline (PJ) .453x.453in. body, .180in. height (max), .050in. pitch

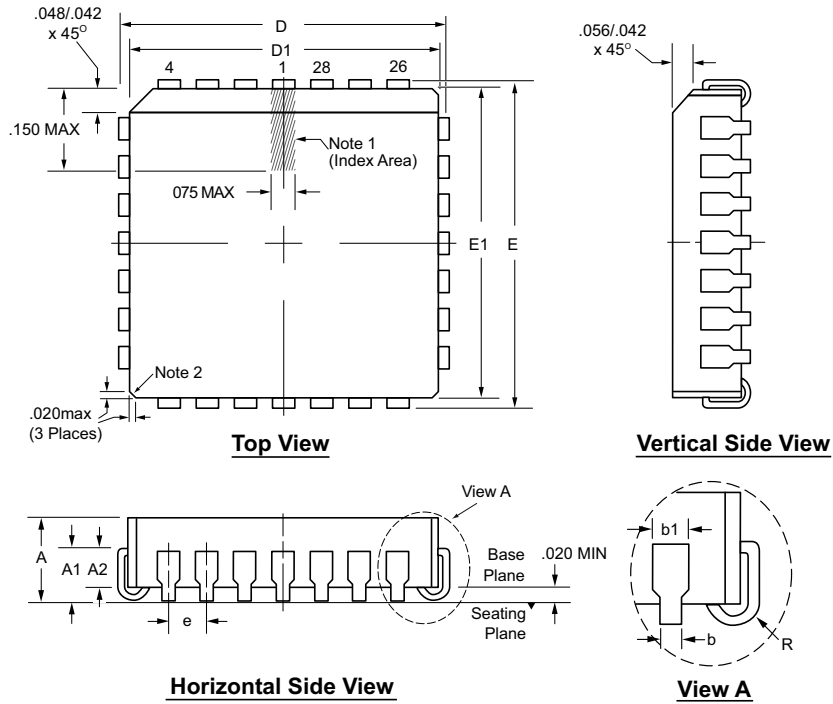

Note: For the most current package drawings, see the Microchip Packaging Specification at www.microchip.com/packaging.

Notes:

1. A Pin 1 identifier must be located in the index area indicated. The Pin 1 identifier can be: a molded mark/identifier; an embedded metal marker; or a printed indicator.
2. Actual shape of this feature may vary.

Symbol		A	A1	A2	b	b1	D	D1	E	E1	e	R
Dimension (inches)	MIN	.165	.090	.062	.013	.026	.485	.450	.485	.450	.050 BSC	.025
	NOM	.172	.105	-	-	-	.490	.453	.490	.453		.035
	MAX	.180	.120	.083	.021	.032	.495	.456	.495	.456		.045

JEDEC Registration MS-018, Variation AB, Issue A, June, 1993.
 Drawings not to scale.

28-Lead SOW (Wide Body) Package Outline (WG) 17.90x7.50mm body, 2.65mm height (max), 1.27mm pitch

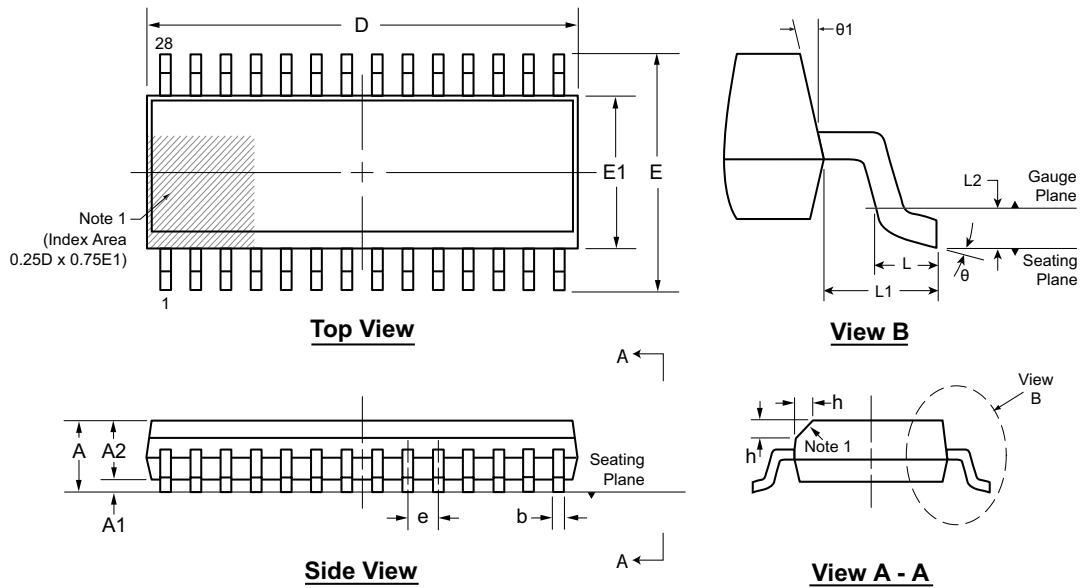

Note: For the most current package drawings, see the Microchip Packaging Specification at www.microchip.com/packaging.

Note:

1. A Pin 1 identifier must be located in the index area indicated. The Pin 1 identifier can be: a molded mark/identifier; an embedded metal marker; or a printed indicator.

Symbol	A	A1	A2	b	D	E	E1	e	h	L	L1	L2	θ	$\theta 1$
Dimension (mm)	MIN	2.15*	0.10	2.05	0.31	17.70*	9.97*	7.40*	0.25	0.40	1.40 REF	0.25 BSC	0°	5°
	NOM	-	-	-	-	17.90	10.30	7.50	-	-			-	-
	MAX	2.65	0.30	2.55*	0.51	18.10*	10.63*	7.60*	0.75	1.27			8°	15°

JEDEC Registration MS-013, Variation AE, Issue E, Sep. 2005.

* This dimension is not specified in the JEDEC drawing.

Drawings are not to scale.

HV5812

NOTES:

APPENDIX A: REVISION HISTORY

Revision A (October 2016)

- Converted Supertex Doc# DSFP-HV5812 to Microchip DS20005629A
- Changed the packaging quantity of 28-lead PLCC (PJ M904) from 500/Reel to 750/Reel and 28-lead SOW (WG) from 1000/Reel to 1600/Reel
- Made minor text changes throughout the document

HV5812

PRODUCT IDENTIFICATION SYSTEM

To order or obtain information, e.g., on pricing or delivery, contact your local Microchip representative or sales office.

<u>PART NO.</u>	<u>XX</u>	-	<u>X</u>	-	<u>X</u>
Device	Package Options		Environmental		Media Type
Device:	HV5812	=	20-Channel Serial-Input Vacuum Fluorescent Display Driver for Anode or Grid		
Packages:	P	=	28-lead PDIP		
	PJ	=	28-lead PLCC		
	WG	=	28-lead SOW		
Environmental:	G	=	Lead (Pb)-free/RoHS-compliant Package		
Media Types:	(blank)	=	13/Tube for a P Package		
		=	38/Tube for a PJ Package		
		=	1600/Reel for a WG Package		
	M904	=	750/Reel for a PJ Package		

Examples:	
a) HV5812P-G:	20-Channel Serial-Input Vacuum Fluorescent Display Driver for Anode or Grid, 28-lead PDIP, 13/Tube
b) HV5812PJ-G:	20-Channel Serial-Input Vacuum Fluorescent Display Driver for Anode or Grid, 28-lead PLCC, 38/Tube
c) HV5812PJ-G-M904:	20-Channel Serial-Input Vacuum Fluorescent Display Driver for Anode or Grid, 28-lead PLCC, 750/Reel
d) HV5812WG-G:	20-Channel Serial-Input Vacuum Fluorescent Display Driver for Anode or Grid, 28-lead SOW, 1600/Reel

Note the following details of the code protection feature on Microchip devices:

- Microchip products meet the specification contained in their particular Microchip Data Sheet.
- Microchip believes that its family of products is one of the most secure families of its kind on the market today, when used in the intended manner and under normal conditions.
- There are dishonest and possibly illegal methods used to breach the code protection feature. All of these methods, to our knowledge, require using the Microchip products in a manner outside the operating specifications contained in Microchip's Data Sheets. Most likely, the person doing so is engaged in theft of intellectual property.
- Microchip is willing to work with the customer who is concerned about the integrity of their code.
- Neither Microchip nor any other semiconductor manufacturer can guarantee the security of their code. Code protection does not mean that we are guaranteeing the product as “unbreakable.”

Code protection is constantly evolving. We at Microchip are committed to continuously improving the code protection features of our products. Attempts to break Microchip's code protection feature may be a violation of the Digital Millennium Copyright Act. If such acts allow unauthorized access to your software or other copyrighted work, you may have a right to sue for relief under that Act.

Information contained in this publication regarding device applications and the like is provided only for your convenience and may be superseded by updates. It is your responsibility to ensure that your application meets with your specifications. MICROCHIP MAKES NO REPRESENTATIONS OR WARRANTIES OF ANY KIND WHETHER EXPRESS OR IMPLIED, WRITTEN OR ORAL, STATUTORY OR OTHERWISE, RELATED TO THE INFORMATION, INCLUDING BUT NOT LIMITED TO ITS CONDITION, QUALITY, PERFORMANCE, MERCHANTABILITY OR FITNESS FOR PURPOSE. Microchip disclaims all liability arising from this information and its use. Use of Microchip devices in life support and/or safety applications is entirely at the buyer's risk, and the buyer agrees to defend, indemnify and hold harmless Microchip from any and all damages, claims, suits, or expenses resulting from such use. No licenses are conveyed, implicitly or otherwise, under any Microchip intellectual property rights unless otherwise stated.

Microchip received ISO/TS-16949:2009 certification for its worldwide headquarters, design and wafer fabrication facilities in Chandler and Tempe, Arizona; Gresham, Oregon and design centers in California and India. The Company's quality system processes and procedures are for its PIC® MCUs and dsPIC® DSCs, KEELOQ® code hopping devices, Serial EEPROMs, microperipherals, nonvolatile memory and analog products. In addition, Microchip's quality system for the design and manufacture of development systems is ISO 9001:2000 certified.

**QUALITY MANAGEMENT SYSTEM
CERTIFIED BY DNV
= ISO/TS 16949 =**

Trademarks

The Microchip name and logo, the Microchip logo, AnyRate, dsPIC, FlashFlex, flexPWR, Heldo, JukeBlox, KeeLoq, KeeLoq logo, Klear, LANCheck, LINK MD, MediaLB, MOST, MOST logo, MPLAB, OptoLyzer, PIC, PICSTART, PIC32 logo, RightTouch, SpyNIC, SST, SST Logo, SuperFlash and UNI/O are registered trademarks of Microchip Technology Incorporated in the U.S.A. and other countries.

ClockWorks, The Embedded Control Solutions Company, ETHERSYNCH, Hyper Speed Control, HyperLight Load, IntellIMOS, mTouch, Precision Edge, and QUIET-WIRE are registered trademarks of Microchip Technology Incorporated in the U.S.A.

Analog-for-the-Digital Age, Any Capacitor, AnyIn, AnyOut, BodyCom, chipKIT, chipKIT logo, CodeGuard, dsPICDEM, dsPICDEM.net, Dynamic Average Matching, DAM, ECAN, EtherGREEN, In-Circuit Serial Programming, ICSP, Inter-Chip Connectivity, JitterBlocker, KlearNet, KlearNet logo, MiWi, motorBench, MPASM, MPF, MPLAB Certified logo, MPLIB, MPLINK, MultiTRAK, NetDetach, Omniscient Code Generation, PICDEM, PICDEM.net, PICkit, PICtail, PureSilicon, RightTouch logo, REAL ICE, Ripple Blocker, Serial Quad I/O, SQL, SuperSwitcher, SuperSwitcher II, Total Endurance, TSHARC, USBCheck, VariSense, ViewSpan, WiperLock, Wireless DNA, and ZENA are trademarks of Microchip Technology Incorporated in the U.S.A. and other countries.

SQTP is a service mark of Microchip Technology Incorporated in the U.S.A.

Silicon Storage Technology is a registered trademark of Microchip Technology Inc. in other countries.

GestIC is a registered trademarks of Microchip Technology Germany II GmbH & Co. KG, a subsidiary of Microchip Technology Inc., in other countries.

All other trademarks mentioned herein are property of their respective companies.

© 2016, Microchip Technology Incorporated, Printed in the U.S.A., All Rights Reserved.

ISBN: 978-1-5224-0999-1



MICROCHIP

Worldwide Sales and Service

AMERICAS

Corporate Office

2355 West Chandler Blvd.
Chandler, AZ 85224-6199

Tel: 480-792-7200

Fax: 480-792-7277

Technical Support:

[http://www.microchip.com/
support](http://www.microchip.com/support)

Web Address:

www.microchip.com

Atlanta

Duluth, GA

Tel: 678-957-9614

Fax: 678-957-1455

Austin, TX

Tel: 512-257-3370

Boston

Westborough, MA

Tel: 774-760-0087

Fax: 774-760-0088

Chicago

Itasca, IL

Tel: 630-285-0071

Fax: 630-285-0075

Cleveland

Independence, OH

Tel: 216-447-0464

Fax: 216-447-0643

Dallas

Addison, TX

Tel: 972-818-7423

Fax: 972-818-2924

Detroit

Novi, MI

Tel: 248-848-4000

Houston, TX

Tel: 281-894-5983

Indianapolis

Noblesville, IN

Tel: 317-773-8323

Fax: 317-773-5453

Los Angeles

Mission Viejo, CA

Tel: 949-462-9523

Fax: 949-462-9608

New York, NY

Tel: 631-435-6000

San Jose, CA

Tel: 408-735-9110

Canada - Toronto

Tel: 905-695-1980

Fax: 905-695-2078

ASIA/PACIFIC

Asia Pacific Office

Suites 3707-14, 37th Floor
Tower 6, The Gateway
Harbour City, Kowloon

Hong Kong

Tel: 852-2943-5100

Fax: 852-2401-3431

Australia - Sydney

Tel: 61-2-9868-6733

Fax: 61-2-9868-6755

China - Beijing

Tel: 86-10-8569-7000

Fax: 86-10-8528-2104

China - Chengdu

Tel: 86-28-8665-5511

Fax: 86-28-8665-7889

China - Chongqing

Tel: 86-23-8980-9588

Fax: 86-23-8980-9500

China - Dongguan

Tel: 86-769-8702-9880

China - Guangzhou

Tel: 86-20-8755-8029

China - Hangzhou

Tel: 86-571-8792-8115

Fax: 86-571-8792-8116

China - Hong Kong SAR

Tel: 852-2943-5100

Fax: 852-2401-3431

China - Nanjing

Tel: 86-25-8473-2460

Fax: 86-25-8473-2470

China - Qingdao

Tel: 86-532-8502-7355

Fax: 86-532-8502-7205

China - Shanghai

Tel: 86-21-5407-5533

Fax: 86-21-5407-5066

China - Shenyang

Tel: 86-24-2334-2829

Fax: 86-24-2334-2393

China - Shenzhen

Tel: 86-755-8864-2200

Fax: 86-755-8203-1760

China - Wuhan

Tel: 86-27-5980-5300

Fax: 86-27-5980-5118

China - Xian

Tel: 86-29-8833-7252

Fax: 86-29-8833-7256

ASIA/PACIFIC

China - Xiamen

Tel: 86-592-2388138

Fax: 86-592-2388130

China - Zhuhai

Tel: 86-756-3210040

Fax: 86-756-3210049

India - Bangalore

Tel: 91-80-3090-4444

Fax: 91-80-3090-4123

India - New Delhi

Tel: 91-11-4160-8631

Fax: 91-11-4160-8632

India - Pune

Tel: 91-20-3019-1500

Japan - Osaka

Tel: 81-6-6152-7160

Fax: 81-6-6152-9310

Japan - Tokyo

Tel: 81-3-6880-3770

Fax: 81-3-6880-3771

Korea - Daegu

Tel: 82-53-744-4301

Fax: 82-53-744-4302

Korea - Seoul

Tel: 82-2-554-7200

Fax: 82-2-558-5932 or

82-2-558-5934

Malaysia - Kuala Lumpur

Tel: 60-3-6201-9857

Fax: 60-3-6201-9859

Malaysia - Penang

Tel: 60-4-227-8870

Fax: 60-4-227-4068

Philippines - Manila

Tel: 63-2-634-9065

Fax: 63-2-634-9069

Singapore

Tel: 65-6334-8870

Fax: 65-6334-8850

Taiwan - Hsin Chu

Tel: 886-3-5778-366

Fax: 886-3-5770-955

Taiwan - Kaohsiung

Tel: 886-7-213-7828

Taiwan - Taipei

Tel: 886-2-2508-8600

Fax: 886-2-2508-0102

Thailand - Bangkok

Tel: 66-2-694-1351

Fax: 66-2-694-1350

EUROPE

Austria - Wels

Tel: 43-7242-2244-39

Fax: 43-7242-2244-393

Denmark - Copenhagen

Tel: 45-4450-2828

Fax: 45-4485-2829

France - Paris

Tel: 33-1-69-53-63-20

Fax: 33-1-69-30-90-79

Germany - Dusseldorf

Tel: 49-2129-3766400

Germany - Karlsruhe

Tel: 49-721-625370

Germany - Munich

Tel: 49-89-627-144-0

Fax: 49-89-627-144-44

Italy - Milan

Tel: 39-0331-742611

Fax: 39-0331-466781

Italy - Venice

Tel: 39-049-7625286

Netherlands - Drunen

Tel: 31-416-690399

Fax: 31-416-690340

Poland - Warsaw

Tel: 48-22-3325737

Spain - Madrid

Tel: 34-91-708-08-90

Fax: 34-91-708-08-91

Sweden - Stockholm

Tel: 46-8-5090-4654

UK - Wokingham

Tel: 44-118-921-5800

Fax: 44-118-921-5820

06/23/16

Looking for pricing, stock, or lifecycle information?

Click below to explore more details on WIN SOURCE:

- ⊖ [View HV5812WG-G on WIN SOURCE](#)
- ⊖ [Microchip Technology](#) Information

Optimize Your Supply Chain with WIN SOURCE Solutions

- ✓ Global Sourcing Solution
- ✓ Obsolete Management
- ✓ Cost Control Management
- ✓ Shortage Management
- ✓ Alternative Solution
- ✓ Excess Inventory Management