



# THE DATASHEET OF HV230G1-G



# Low Charge Injection, 8-Channel, High Voltage Analog Switches with Bleed Resistors

## Features

- ▶ HVCMOS® technology for high performance
- ▶ Very low quiescent power dissipation (-10µA max.)
- ▶ Output on-resistance typically (22Ω typ.)
- ▶ Integrated bleed resistors on the outputs
- ▶ Low parasitic capacitances
- ▶ DC to 50MHz small signal frequency response
- ▶ -60dB typical output OFF isolation at 5.0MHz
- ▶ CMOS logic circuitry for low power
- ▶ Excellent noise immunity
- ▶ ON-chip shift register, latch and clear logic circuitry
- ▶ Flexible high voltage supplies

## Applications

- ▶ Medical ultrasound imaging
- ▶ Piezoelectric transducer drivers

## General Description

The Supertex HV230 is a low charge injection 8-channel, high-voltage, analog switch integrated circuit (IC) with bleed resistors. This device can be used in applications requiring high voltage switching controlled by low voltage control signals, such as ultrasound imaging and printers. The bleed resistors eliminate voltage built up on capacitive loads such as piezoelectric transducers. Input data is shifted into an 8-bit shift register which can then be retained in an 8-bit latch. To reduce any possible clock feed-through noise, Latch Enable ( $\overline{LE}$ ) should be left high until all bits are clocked in. Using HVCMOS® technology, this switch combines high voltage bilateral DMOS switches and low power CMOS logic to provide efficient control of high voltage analog signals.

This IC is suitable for various combinations of high voltage supplies, e.g.,  $V_{PP}/V_{NN}$ : +50V/-150V, or +100V/-100V.

## Block Diagram

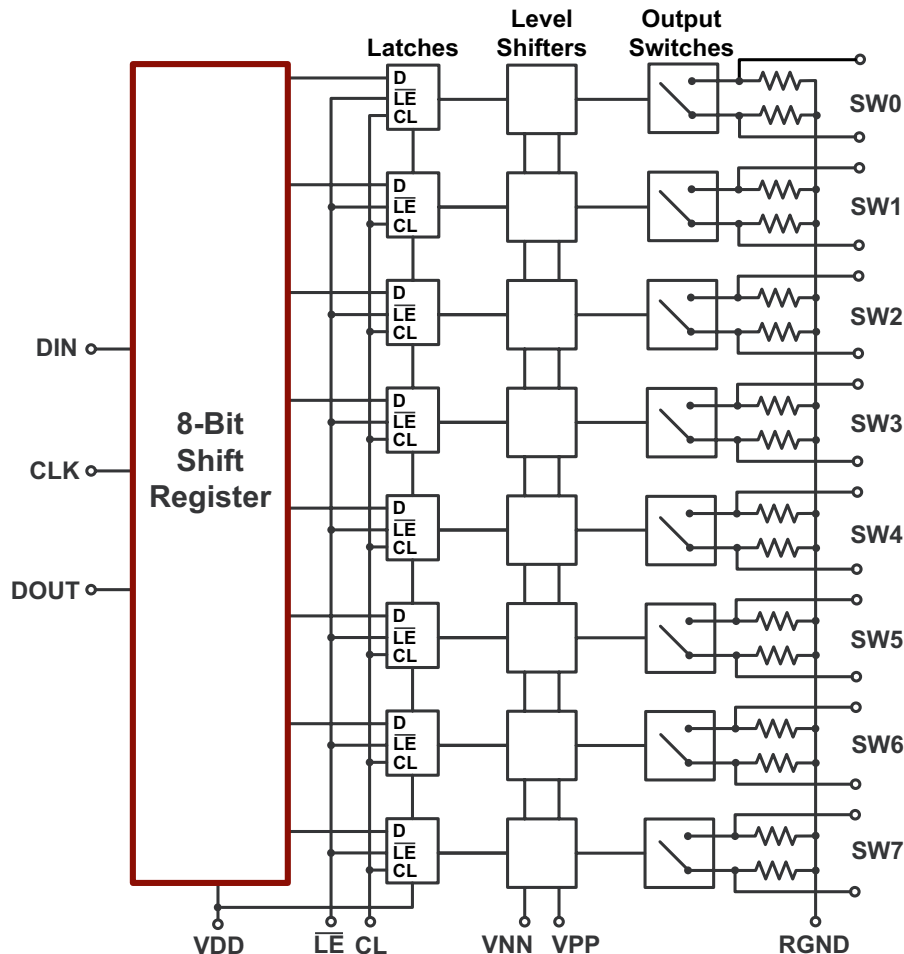

## Ordering Information

Part Number	Package Option	Packing
HV230G1-G	26-Lead LLGA	400/Tray
HV230GA-G	26-Ball fpBGA	<b>Consult factory</b>

-G denotes a lead (Pb)-free / RoHS compliant package

## Pin Configuration

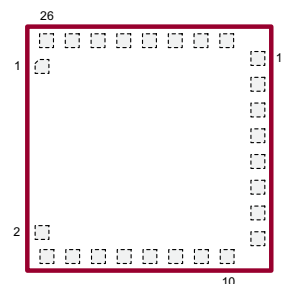

**26-Lead LLGA**  
(top view)

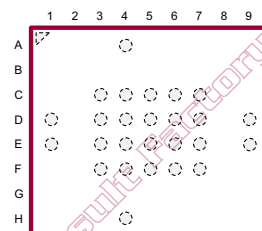

**26-Ball fpBGA**  
(top view)

## Absolute Maximum Ratings

Parameter	Value
$V_{DD}$ logic power supply voltage	-0.5V to +15V
$V_{PP} - V_{NN}$ supply voltage	220V
$V_{PP}$ positive high voltage supply	-0.5V to $V_{NN} + 200V$
$V_{NN}$ negative high voltage supply	+0.5V to -200V
Logic input voltages	-0.5V to $V_{DD} + 0.3V$
Analog signal range	$V_{NN}$ to $V_{PP}$
Peak analog signal current/channel	3.0A
Storage temperature	-65°C to +150°C
Power dissipation:	
26-Lead LLGA	1.0W
26-Ball fpBGA	1.0W

Absolute Maximum Ratings are those values beyond which damage to the device may occur. Functional operation under these conditions is not implied. Continuous operation of the device at the absolute rating level may affect device reliability. All voltages are referenced to device ground.

## Typical Thermal Resistance

Package	$\theta_{ja}$
26-Lead LLGA	41°C/W
26-Ball fpBGA	-

## Product Marking

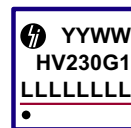

YY = Year Sealed  
WW = Week Sealed  
L = Lot Number  
\_\_\_\_\_ = "Green" Packaging

Package may or may not include the following marks: Si or

**26-Lead LLGA**



YY = Year Sealed  
WW = Week Sealed  
L = Lot Number  
\_\_\_\_\_ = "Green" Packaging

Package may or may not include the following marks: Si or

**26-Ball fpBGA**

## Operating Conditions

Sym	Parameter	Value
$V_{DD}$	Logic power supply voltage <sup>1,3</sup>	4.5V to 13.2V
$V_{PP}$	Positive high voltage supply <sup>1,3</sup>	40V to $V_{NN} + 200V$
$V_{NN}$	Negative high voltage supply <sup>1,3</sup>	-40V to -160V
$V_{IH}$	High level input voltage	$V_{DD} - 1.5V$ to $V_{DD}$
$V_{IL}$	Low-level input voltage	0V to 1.5V
$V_{SIG}$	Analog signal voltage peak-to-peak <sup>2</sup>	$V_{NN} + 10V$ to $V_{PP} - 10V$
$T_A$	Operating free air temperature	0°C to 70°C

### Notes:

- Power up/down sequence is arbitrary except GND must be powered-up first and powered-down last.
- $V_{SIG}$  must be  $V_{NN} \leq V_{SIG} \leq V_{PP}$  or floating during power up/down transition.
- Rise and fall times of power supplies  $V_{DD}$ ,  $V_{PP}$  and  $V_{NN}$  should not be less than 1.0msec.

## DC Electrical Characteristics (Over operating conditions unless otherwise specified)

Sym	Parameter	0°C		+25°C			+70°C		Unit	Conditions	
		Min	Max	Min	Typ	Max	Min	Max			
$R_{ONS}$	Small signal switch ON-resistance	-	30	-	-	38	-	48	$\Omega$	$I_{SIG} = 5.0mA$	$V_{PP} = +40V$ $V_{NN} = -160V$
		-	25	-	-	27	-	32		$I_{SIG} = 200mA$	$V_{PP} = +100V$ $V_{NN} = -100V$
		-	25	-	-	27	-	30		$I_{SIG} = 5.0mA$	$V_{PP} = +160V$ $V_{NN} = -40V$
		-	18	-	-	24	-	27		$I_{SIG} = 200mA$	
		-	23	-	-	25	-	30			
		-	22	-	-	25	-	27			
$\Delta R_{ONS}$	Small signal switch ON-resistance matching	-	20	-	-	20	-	20	%	$I_{SIG} = 5.0mA, V_{PP} = +100V,$ $V_{NN} = -100V$	
$R_{ONL}$	Large signal switch ON-resistance	-	-	-	15	-	-	-	$\Omega$	$V_{SIG} = V_{PP} - 10V, I_{SIG} = 1.0A$	
$R_{INT}$	Output switch shunt resistance	-	-	20	-	50	-	-	K $\Omega$	Output switch to $R_{GND}$ $I_{RINT} = 0.5mA$	
$I_{SOL}$	Switch OFF leakage per switch	-	5.0	-	-	10	-	15	$\mu A$	$V_{SIG} = V_{PP} - 10V$	
$V_{OS}$	DC offset switch OFF	-	300	-	-	300	-	300	mV	No load	
	DC offset switch ON	-	500	-	-	500	-	500	mV	No load	
$I_{PPQ}$	Quiescent $V_{PP}$ supply current	-	-	-	-	50	-	-	$\mu A$	All switches OFF	
$I_{NNQ}$	Quiescent $V_{NN}$ supply current	-	-	-	-	-50	-	-	$\mu A$	All switches OFF	
$I_{PPQ}$	Quiescent $V_{PP}$ supply current	-	-	-	-	50	-	-	$\mu A$	All switches ON, $I_{SW} = 5.0mA$	
$I_{NNQ}$	Quiescent $V_{NN}$ supply current	-	-	-	-	-50	-	-	$\mu A$	All switches ON, $I_{SW} = 5.0mA$	
$I_{SW}$	Switch output peak current	-	3.0	-	-	2.0	-	2.0	A	$V_{SIG}$ duty cycle -0.1%	
$f_{SW}$	Output switching frequency	-	-	-	-	50	-	-	kHz	Duty cycle = 50%	
$I_{PP}$	Supply current	-	6.5	-	-	7.0	-	8.0	mA	$V_{PP} = +40V$ $V_{NN} = -160V$	All output switches are turning On and Off at 50kHz with no load
		-	4.0	-	-	5.0	-	5.5		$V_{PP} = +100V$ $V_{NN} = -100V$	
		-	4.0	-	-	5.0	-	5.5		$V_{PP} = +160V$ $V_{NN} = -40V$	
$I_{NN}$	Supply current	-	6.5	-	-	7.0	-	8.0	mA	$V_{PP} = +40V$ $V_{NN} = -160V$	All output switches are turning On and Off at 50kHz with no load
		-	4.0	-	-	5.0	-	5.5		$V_{PP} = +100V$ $V_{NN} = -100V$	
		-	4.0	-	-	5.0	-	5.5		$V_{PP} = +160V$ $V_{NN} = -40V$	
$I_{DD}$	Logic supply average current	-	4.0	-	-	4.0	-	4.0	mA	$f_{CLK} = 5.0MHz, V_{DD} = 5.0V$	
$I_{DDQ}$	Logic supply quiescent current	-	10	-	-	10	-	10	$\mu A$	---	
$I_{SOR}$	Data out source current	0.45	-	0.45	-	-	0.40	-	mA	$V_{OUT} = V_{DD} - 0.7V$	
$I_{SINK}$	Data out sink current	0.45	-	0.45	-	-	0.40	-	mA	$V_{OUT} = 0.7V$	
$C_{IN}$	Logic input capacitance	-	10	-	-	10	-	10	pF	---	

**AC Electrical Characteristics** (Over recommended operating conditions,  $V_{DD} = 5.0V$ , unless otherwise specified)

Sym	Parameter	0°C		+25°C			+70°C		Unit	Conditions
		Min	Max	Min	Typ	Max	Min	Max		
$t_{SD}$	Set up time before $\overline{LE}$ rises	150	-	150	-	-	150	-	ns	---
$t_{WLE}$	Time width of $\overline{LE}$	150	-	150	-	-	150	-	ns	---
$t_{DO}$	Clock delay time to data out	55	150	60	-	150	70	150	ns	---
$t_{WCL}$	Time width of CL	150	-	150	-	-	150	-	ns	---
$t_{SU}$	Set up time data to clock	15	-	15	-	-	20	-	ns	---
$t_H$	Hold time data from clock	35	-	35	-	-	35	-	ns	---
$f_{CLK}$	Clock frequency	-	5.0	-	-	5.0	-	5.0	MHz	50% Duty cycle, $f_{DATA} = f_{CLK}/2$
$t_R, t_F$	Clock rise and fall times	-	1.0	-	-	1.0	-	1.0	$\mu s$	---
$t_{ON}$	Turn ON time	-	5.0	-	-	5.0	-	5.0	$\mu s$	$V_{SIG} = V_{PP} - 10V, R_L = 10k\Omega$
$t_{OFF}$	Turn OFF time	-	5.0	-	-	5.0	-	5.0	$\mu s$	$V_{SIG} = V_{PP} - 10V, R_L = 10k\Omega$
dv/dt	Maximum $V_{SIG}$ slew rate	-	20	-	-	20	-	20	V/ns	$V_{PP} = +160V, V_{NN} = -40V$
		-	20	-	-	20	-	20		$V_{PP} = +100V, V_{NN} = -100V$
		-	20	-	-	20	-	20		$V_{PP} = +40V, V_{NN} = -160V$
$K_O$	OFF isolation	-30	-	-30	-	-	-30	-	dB	f = 5.0MHz, 1.0k $\Omega$ /15pF load
		-58	-	-58	-	-	-58	-		f = 5.0MHz, 50 $\Omega$ load
$K_{CR}$	Switch crosstalk	-60	-	-60	-	-	-60	-	dB	f = 5.0MHz, 50 $\Omega$ load
$I_{ID}$	Output switch isolation diode current	-	300	-	-	300	-	300	mA	300ns pulse width, 2.0% duty cycle
$C_{SG(OFF)}$	OFF capacitance SW to GND	5.0	17	5.0	-	17	5.0	17	pF	0V, f = 1.0MHz
$C_{SG(ON)}$	ON capacitance SW to GND	25	50	25	-	50	25	50	pF	0V, f = 1.0MHz
$+V_{SPK}$	Output voltage spike	-	-	-	-	150	-	-	mV	$V_{PP} = +40V, V_{NN} = -160V,$ $R_L = 50\Omega$
$-V_{SPK}$		-	-	-	-	150	-	-		
$+V_{SPK}$		-	-	-	-	150	-	-		$V_{PP} = +100V, V_{NN} = -100V,$ $R_L = 50\Omega$
$-V_{SPK}$		-	-	-	-	150	-	-		
$+V_{SPK}$		-	-	-	-	150	-	-		$V_{PP} = +160V, V_{NN} = -40V,$ $R_L = 50\Omega$
$-V_{SPK}$		-	-	-	-	150	-	-		

Truth Table

D0	D1	D2	D3	D4	D5	D6	D7	$\overline{LE}$	CLK	SW0	SW1	SW2	SW3	SW4	SW5	SW6	SW7
L								L	L	OFF							
H								L	L	ON							
	L							L	L		OFF						
	H							L	L		ON						
		L						L	L			OFF					
		H						L	L			ON					
			L					L	L				OFF				
			H					L	L				ON				
				L				L	L					OFF			
				H				L	L					ON			
					L			L	L						OFF		
					H			L	L						ON		
						L		L	L							OFF	
						H		L	L							ON	
							L	L	L								OFF
							H	L	L								ON
X	X	X	X	X	X	X	X	H	L	Hold Previous State							
X	X	X	X	X	X	X	X	X	H	All Switches OFF							

Notes:

1. The eight switches operate independently.
2. Serial data is clocked in on the L to H transition of the CLK.
3. The switches go to a state retaining their present condition at the rising edge of  $\overline{LE}$ . When  $\overline{LE}$  is low the shift register data flow through the latch.
4.  $D_{OUT}$  is high when data in the shift register 7 is high.
5. Shift register clocking has no effect on the switch states if  $\overline{LE}$  is high.
6. The CLR clear input overrides all other inputs.

Logic Timing Waveforms

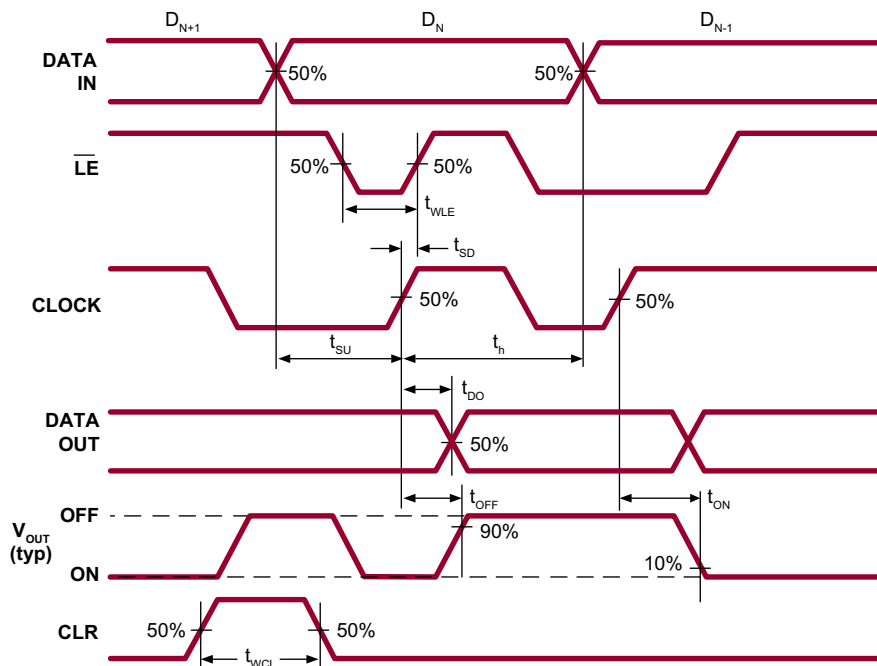

### Test Circuits

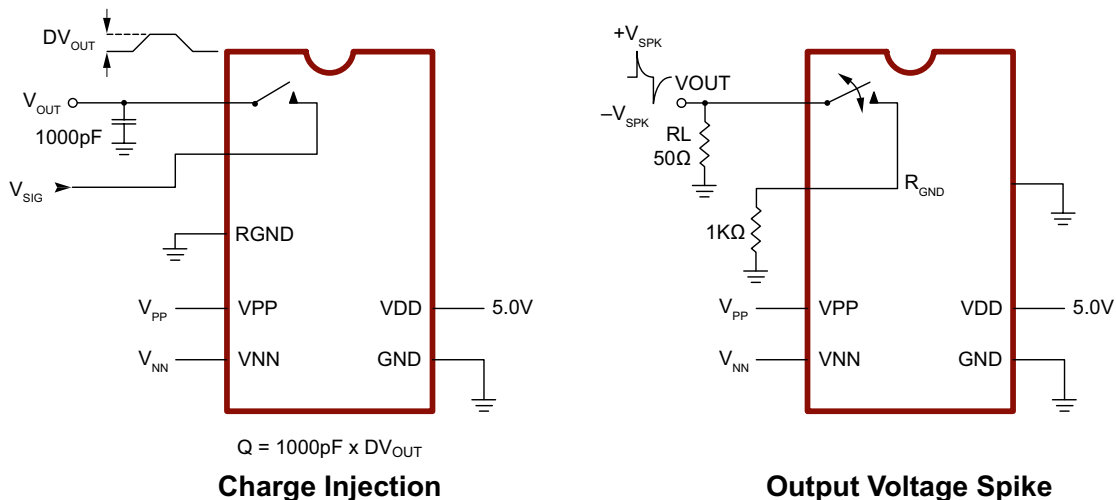
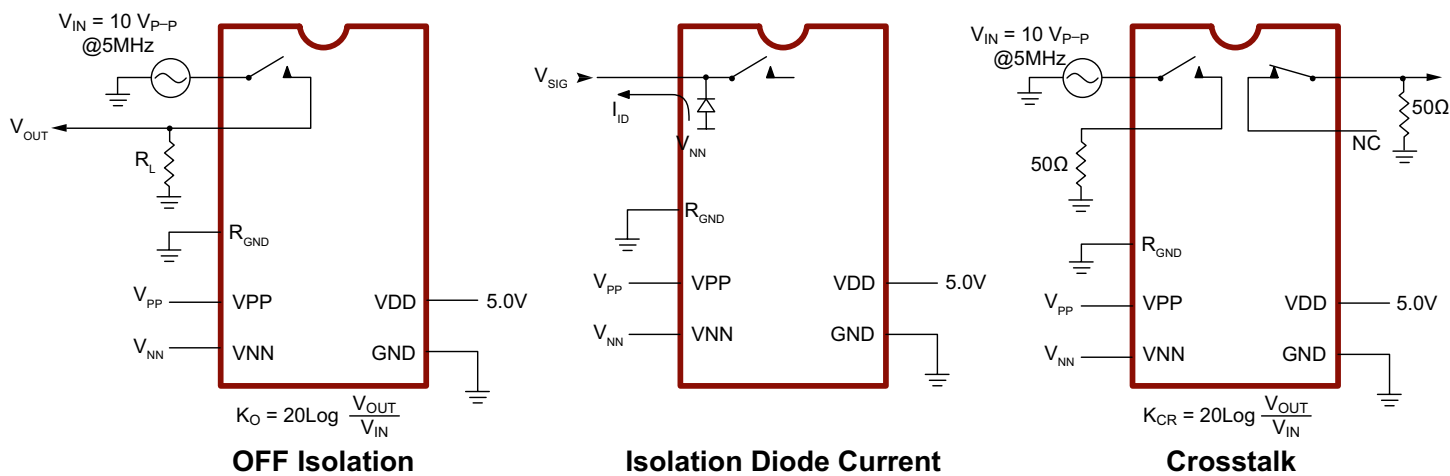
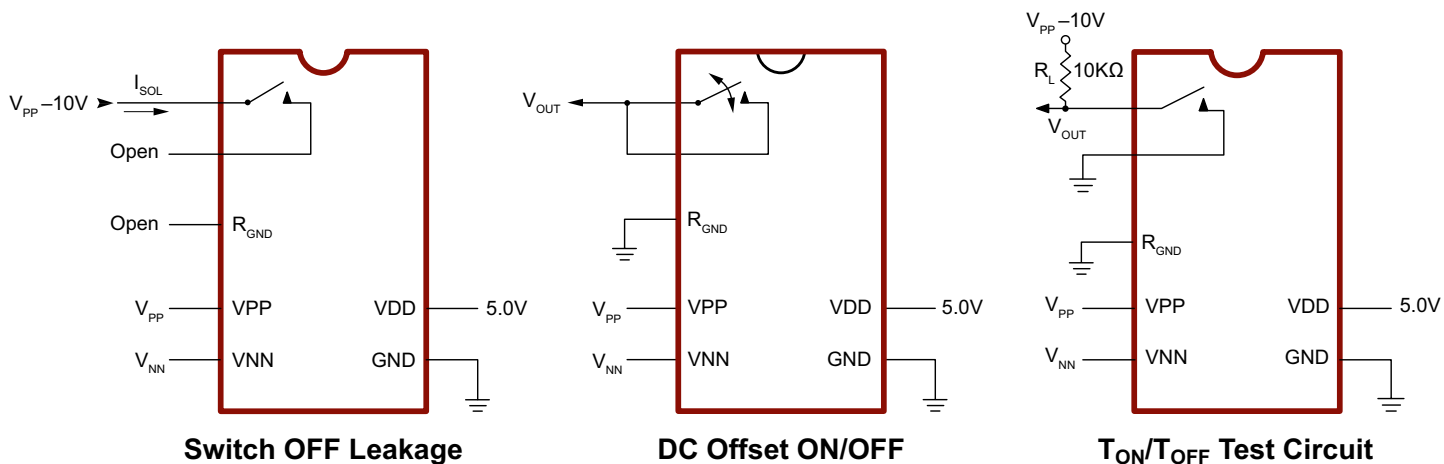

## Pin Description (26-Lead LLGA)

Pin	Function	Pin	Function
1	SW4	14	VDD
2	SW3	15	DIN
3	SW3	16	CLK
4	SW2	17	$\overline{\text{LE}}$
5	SW2	18	CL
6	SW1	19	DOUT
7	SW1	20	SW7
8	SW0	21	SW7
9	SW0	22	SW6
10	VPP	23	SW6
11	VNN	24	SW5
12	RGND	25	SW5
13	GND	26	SW4

## Pin Description (26-Ball fpBGA)

Ball Location	Function	Ball Location	Function
A4	SW1	E1	SW4
C3	SW2	E3	SW4
C4	SW1	E4	SW5
C5	SW0	E5	SW7
C6	VPP	E6	$\overline{\text{LE}}$
C7	VNN	E7	CLK
D1	SW3	E9	DIN
D3	SW3	F3	SW5
D4	SW2	F4	SW6
D5	SW0	F5	SW7
D6	RGND	F6	DOUT
D7	GND	F7	CLR
D9	VDD	H4	SW6

# 26-Lead LLGA Package Outline (G1)

6.00x6.00mm body, 0.60mm height (max), 0.65mm pitch

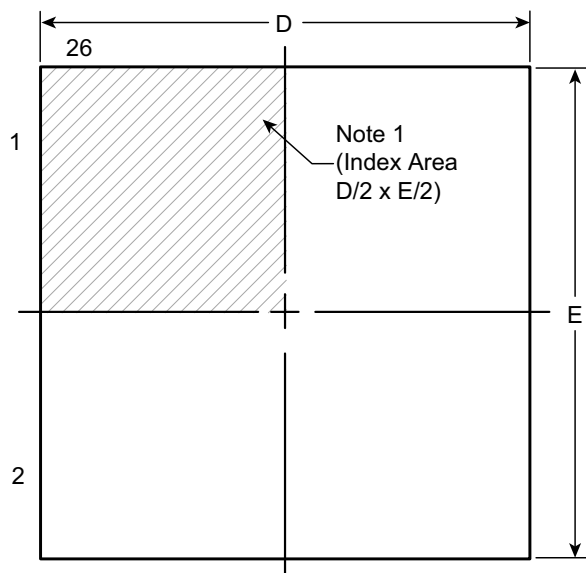

**Top View**

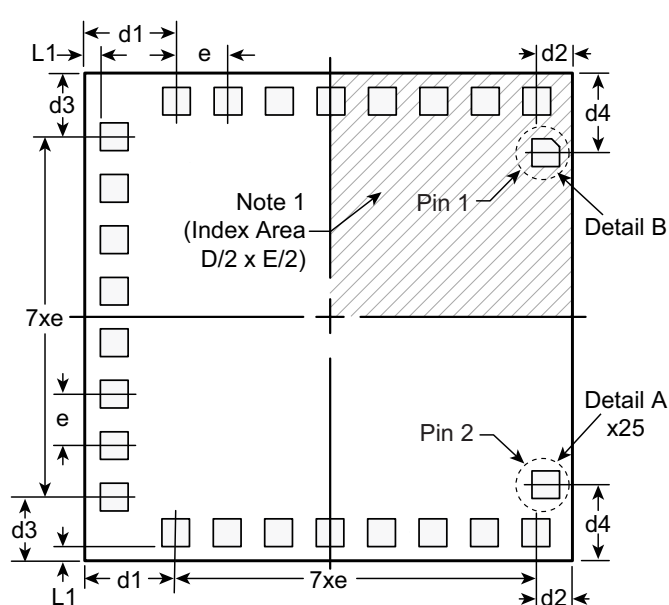

**Bottom View**



**Side View**

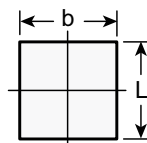

**Detail A**

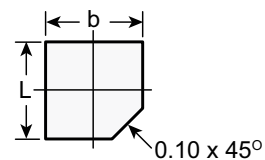

**Detail B**

**Note:**  
 1. A Pin 1 identifier must be located in the index area indicated. The Pin 1 Identifier can be: a molded mark/identifier; an embedded metal marker; or a printed indicator.

Symbol	A	A1	b	D	d1	d2	d3	d4	E	e	L	L1	
Dimension (mm)	MIN	0.50	0.00	0.25	5.90	1.050 REF	0.400 REF	0.725 REF	0.925 REF	5.90	0.65 BSC	0.25	0.10 REF
	NOM	0.55	-	0.35	6.00					6.00		0.35	
	MAX	0.60	0.05	0.45	6.10					6.10		0.45	

Drawings not to scale.

Supertex Doc. #: DSPD-26LLGAG1, Version A090808.

# 26-Ball fpBGA Package Outline (GA)

6.00x5.35mm body, 1.20mm height (max), 0.65mm pitch

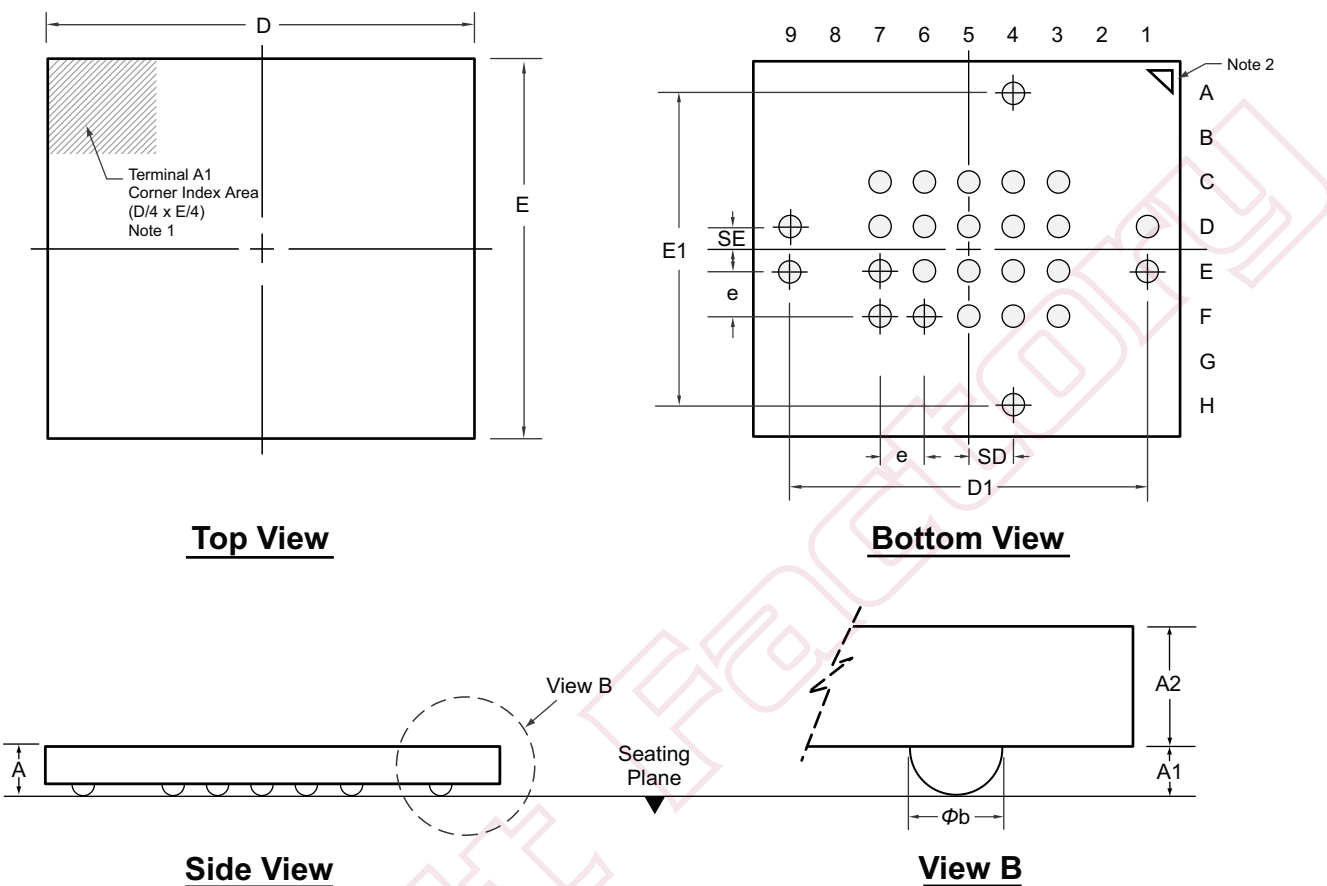

**Notes:**

1. A Ball A1 identifier must be located in the index area indicated. The Ball A1 identifier can be: a molded mark/identifier; an embedded metal marker; or a printed indicator.
2. Corner A1 identifier (actual shape may vary).

Symbol		A	A1	A2	$\phi_b$	D	D1	E	E1	e	SD	SE
Dimension (mm)	MIN	0.844	0.18	0.664	0.25	5.90	5.20 BSC	5.25	4.55 BSC	0.65 BSC	0.65 BSC	0.325 BSC
	NOM	0.994	0.23	0.764	0.30	6.00		5.35				
	MAX	1.200	0.28	0.864	0.35	6.10		5.45				

Drawings not to scale.  
Supertex Doc. #: DSPD-26fpBGAGA, Version A092208.

(The package drawing(s) in this data sheet may not reflect the most current specifications. For the latest package outline information go to <http://www.supertex.com/packaging.html>.)

Supertex inc. does not recommend the use of its products in life support applications, and will not knowingly sell them for use in such applications unless it receives an adequate "product liability indemnification insurance agreement." Supertex inc. does not assume responsibility for use of devices described, and limits its liability to the replacement of the devices determined defective due to workmanship. No responsibility is assumed for possible omissions and inaccuracies. Circuitry and specifications are subject to change without notice. For the latest product specifications refer to the Supertex inc. (website: <http://www.supertex.com>)

## Looking for pricing, stock, or lifecycle information?

Click below to explore more details on WIN SOURCE:

- ⊖ [View HV230G1-G on WIN SOURCE](#)
- ⊖ [Microchip Technology](#) Information

## Optimize Your Supply Chain with WIN SOURCE Solutions

- ✓ Global Sourcing Solution
- ✓ Obsolete Management
- ✓ Cost Control Management
- ✓ Shortage Management
- ✓ Alternative Solution
- ✓ Excess Inventory Management