



# THE DATASHEET OF HMC307QS16GETR



## 1dB LSB GaAs MMIC 5-BIT DIGITAL ATTENUATOR, DC - 4 GHz



### Typical Applications

The HMC307QS16G(E) is ideal for:

- Cellular
- PCS, ISM, MMDS
- Wireless Local Loop

### Features

- 1 dB LSB Steps to 31 dB
- Single Control Line Per Bit
- ± 0.5 dB Typical Bit Error
- Miniature QSOP-16 Package: 29.4 mm<sup>2</sup>

### Functional Diagram

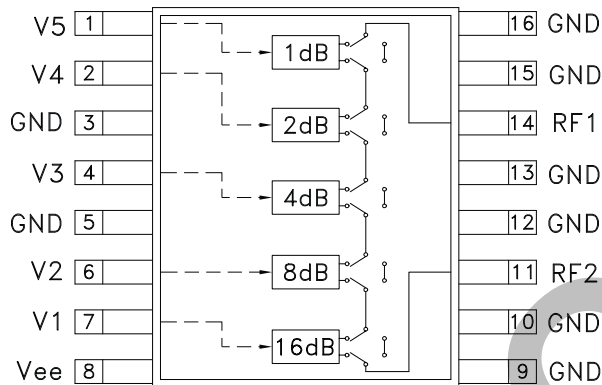

### General Description

The HMC307QS16G(E) are broadband 5-bit GaAs IC digital attenuators in 16 lead QSOP grounded base surface mount plastic packages. Covering DC to 4 GHz, the insertion loss is less than 2 dB typical. The attenuator bit values are 1 (LSB), 2, 4, 8, and 16 dB for a total attenuation of 31 dB. Attenuation accuracy is excellent at ± 0.5 dB typical with an IIP3 of up to +44 dBm. Five bit control voltage inputs, toggled between 0 and -5V, are used to select each attenuation state at less than 50 uA each. A single Vee bias of -5V allows operation down to DC. This product is an excellent alternative to the HMC235QS16G.

### Electrical Specifications, $T_A = +25^\circ\text{C}$ , $V_{ee} = -5\text{V}$ & $V_{CTL} = 0/V_{ee}$

Parameter	Frequency	Min.	Typical	Max.	Units
Insertion Loss	DC - 1.4 GHz		1.8	2.2	dB
	1.4 - 2.3 GHz		1.9	2.4	dB
	2.3 - 2.7 GHz		2.0	2.5	dB
	2.7 - 4.0 GHz		2.1	2.7	dB
Attenuation Range	DC - 4 GHz		31		dB
Return Loss (RF1 & RF2, All Atten. States)	DC - 1.4 GHz	11	15		dB
	1.4 - 2.3 GHz	11	17		dB
	2.3 - 2.7 GHz	10	18		dB
	2.7 - 4.0 GHz	8	15		dB
Attenuation Accuracy: (Referenced to Insertion Loss)	DC - 2.7 GHz	± 0.2 + 3% of Atten. Setting Max			dB
	DC - 2.7 GHz	± 0.3 + 5% of Atten. Setting Max			dB
	2.7 - 4.0 GHz	± 0.3 + 5% of Atten. Setting Max			dB
	2.7 - 4.0 GHz	± 0.6 + 10% of Atten. Setting Max			dB
Input Power for 0.1 dB Compression	0.5 - 4.0 GHz		24		dBm
Input Third Order Intercept Point (Two-tone Input Power = 0 dBm Each Tone)	0.5 - 4.0 GHz		44		dBm
Switching Characteristics	DC - 4 GHz				
		tRISE, tFALL (10/90% RF)		140	ns
		tON, tOFF (50% CTL to 10/90% RF)		160	ns

Information furnished by Analog Devices is believed to be accurate and reliable. However, no responsibility is assumed by Analog Devices for its use, nor for any infringements of patents or other rights of third parties that may result from its use. Specifications subject to change without notice. No license is granted by implication or otherwise under any patent or patent rights of Analog Devices. Trademarks and registered trademarks are the property of their respective owners.

For price, delivery, and to place orders: Analog Devices, Inc., One Technology Way, P.O. Box 9106, Norwood, MA 02062-9106 Phone: 781-329-4700 • Order online at [www.analog.com](http://www.analog.com) Application Support: Phone: 1-800-ANALOG-D



**1dB LSB GaAs MMIC 5-BIT DIGITAL ATTENUATOR, DC - 4 GHz**

**Insertion Loss**

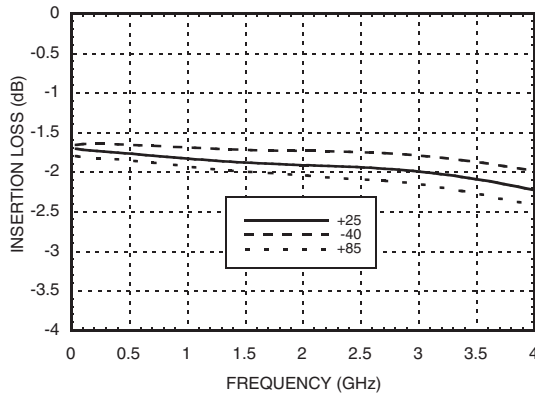

**Return Loss RF1, RF2**  
(Only Major States are Shown)

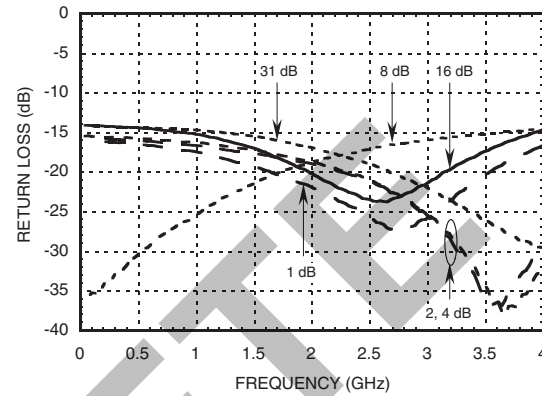

**Normalized Attenuation**  
(Only Major States are Shown)

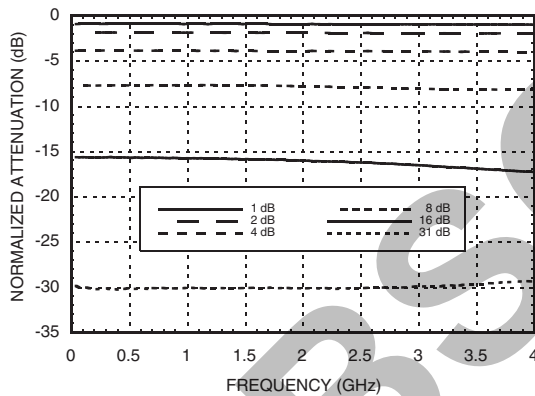

**Absolute Bit Error vs. Attenuation State**

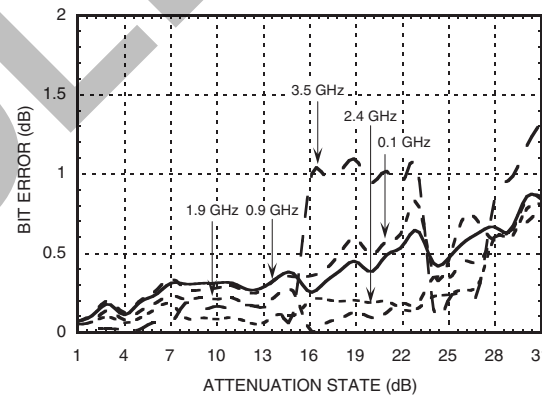

**Absolute Bit Error vs. Frequency**  
(Only Major States are Shown)

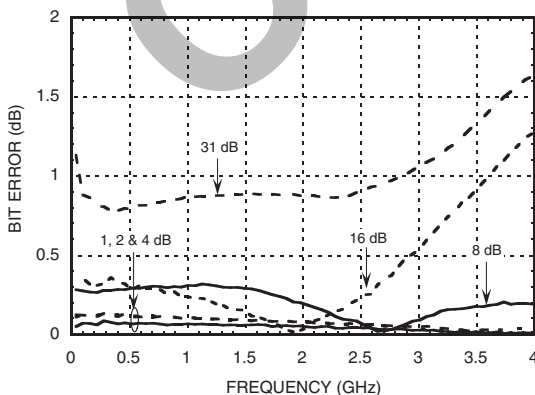

**Relative Phase vs. Frequency**  
(Only Major States are Shown)

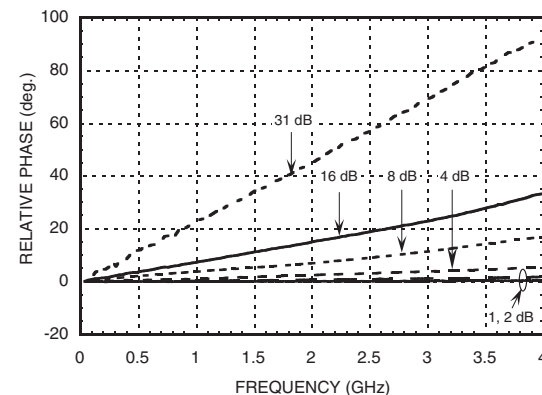

Information furnished by Analog Devices is believed to be accurate and reliable. However, no responsibility is assumed by Analog Devices for its use, nor for any infringements of patents or other rights of third parties that may result from its use. Specifications subject to change without notice. No license is granted by implication or otherwise under any patent or patent rights of Analog Devices. Trademarks and registered trademarks are the property of their respective owners.

For price, delivery, and to place orders: Analog Devices, Inc., One Technology Way, P.O. Box 9106, Norwood, MA 02062-9106 Phone: 781-329-4700 • Order online at [www.analog.com](http://www.analog.com) Application Support: Phone: 1-800-ANALOG-D



**1dB LSB GaAs MMIC 5-BIT DIGITAL ATTENUATOR, DC - 4 GHz**

5

ATTENUATORS - SMT

**Control Voltage**

State	Bias Condition
Low	0 to -3V @ 70 uA Typ.
High	Vee + 0.8V @ 5 uA Typ.

Note: Vee = -5V ± 10%

**Truth Table**

Control Voltage Input					Attenuation State RF1 - RF2
V1 16 dB	V2 8 dB	V3 4 dB	V4 2 dB	V5 1 dB	
Low	Low	Low	Low	Low	Reference I.L.
Low	Low	Low	Low	High	1 dB
Low	Low	Low	High	Low	2 dB
Low	Low	High	Low	Low	4 dB
Low	High	Low	Low	Low	8 dB
High	Low	Low	Low	Low	16 dB
High	High	High	High	High	31 dB Max. Atten.

Any combination of the above states will provide an attenuation approximately equal to the sum of the bits selected.

**Bias Voltage & Current**

Vee Range = -5.0 Vdc ± 10%		
Vee (VDC)	Iee (Typ.) (mA)	Iee (Max.) (mA)
-5.0	3	6

**Application Circuit**

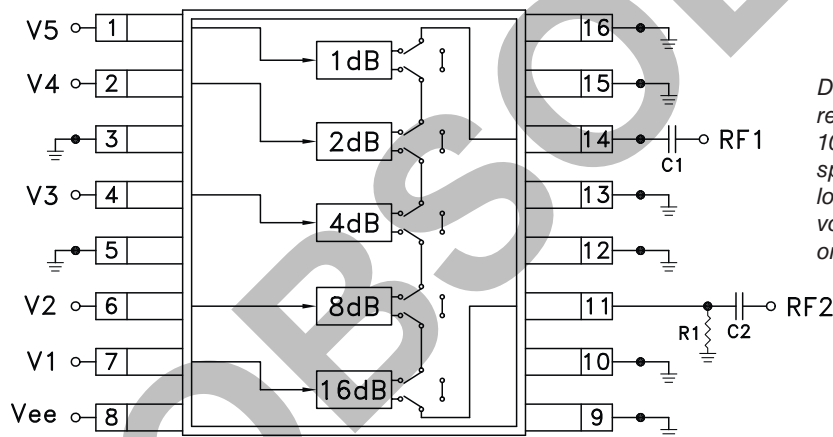

DC Blocking Capacitors C1 & C2 are required on RF1 & RF2. Choose C1 = C2 = 100 pF ~ 0.1 uF to allow lowest customer specific frequency to pass with minimal loss. R1= 5K Ohm is required to supply voltage to the circuit through either Pin 11 or Pin 14.

**Suggested Driver Circuit (One Circuit Required Per Bit Control Input)**

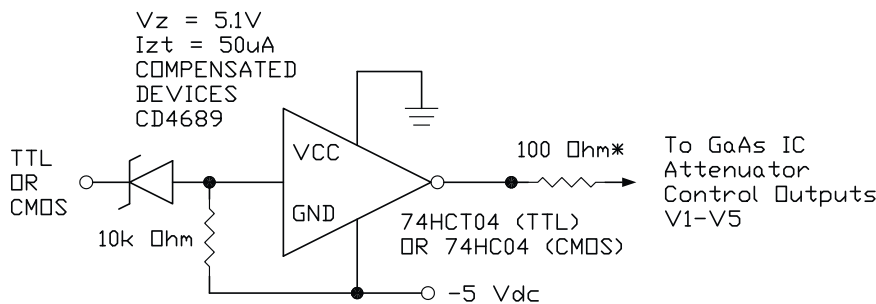

Simple driver using inexpensive standard logic ICs provides fast switching using minimum DC current. \* Recommended value to suppress unwanted RF signals at V1 - V5 control lines.

Information furnished by Analog Devices is believed to be accurate and reliable. However, no responsibility is assumed by Analog Devices for its use, nor for any infringements of patents or other rights of third parties that may result from its use. Specifications subject to change without notice. No license is granted by implication or otherwise under any patent or patent rights of Analog Devices. Trademarks and registered trademarks are the property of their respective owners.

For price, delivery, and to place orders: Analog Devices, Inc., One Technology Way, P.O. Box 9106, Norwood, MA 02062-9106  
Phone: 781-329-4700 • Order online at [www.analog.com](http://www.analog.com)  
Application Support: Phone: 1-800-ANALOG-D



## 1dB LSB GaAs MMIC 5-BIT DIGITAL ATTENUATOR, DC - 4 GHz

### Absolute Maximum Ratings

Control Voltage (V1 - V5)	Vee - 0.5 Vdc
Bias Voltage (Vee)	-7.0 Vdc
Storage Temperature	-65 to +150 °C
Operating Temperature	-40 to +85 °C
RF Input Power (0.5 - 4 GHz)	+26 dBm
ESD Sensitivity (HBM)	Class 1A



ELECTROSTATIC SENSITIVE DEVICE  
OBSERVE HANDLING PRECAUTIONS

### Outline Drawing

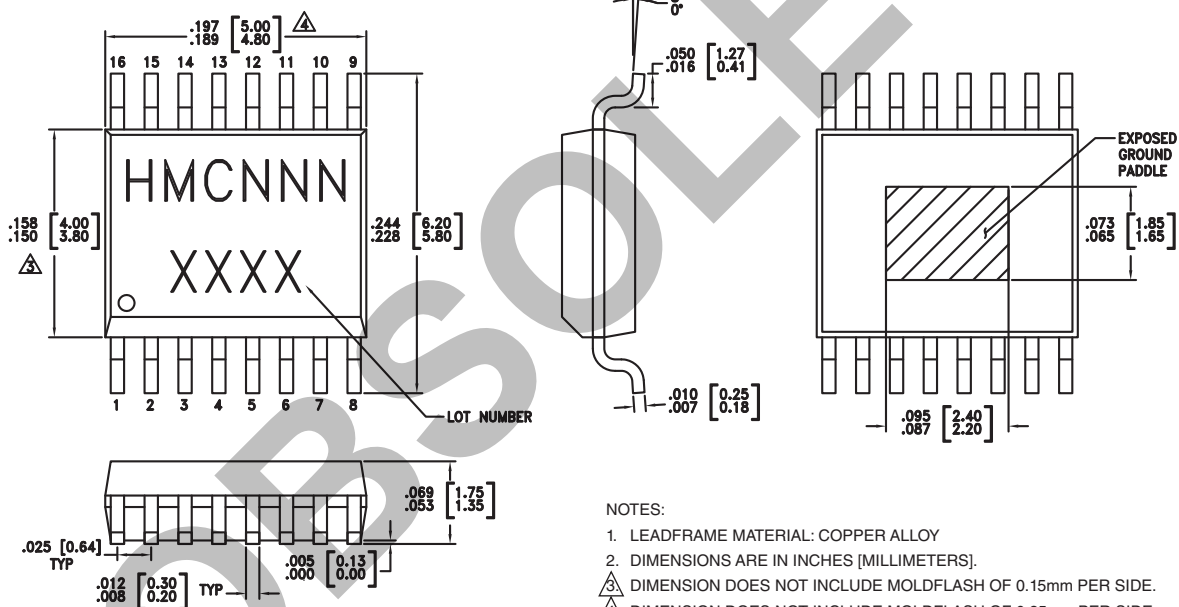

NOTES:

- LEADFRAME MATERIAL: COPPER ALLOY
- DIMENSIONS ARE IN INCHES [MILLIMETERS].
- DIMENSION DOES NOT INCLUDE MOLDFLASH OF 0.15mm PER SIDE.
- DIMENSION DOES NOT INCLUDE MOLDFLASH OF 0.25mm PER SIDE.
- ALL GROUND LEADS AND GROUND PADDLE MUST BE SOLDERED TO PCB RF GROUND.

### Package Information

Part Number	Package Body Material	Lead Finish	MSL Rating	Package Marking <sup>[3]</sup>
HMC307QS16G	Low Stress Injection Molded Plastic	Sn/Pb Solder	MSL1 <sup>[1]</sup>	HMC307 XXXX
HMC307QS16GE	RoHS-compliant Low Stress Injection Molded Plastic	100% matte Sn	MSL1 <sup>[2]</sup>	HMC307 XXXX

[1] Max peak reflow temperature of 235 °C

[2] Max peak reflow temperature of 260 °C

[3] 4-Digit lot number XXXX

Information furnished by Analog Devices is believed to be accurate and reliable. However, no responsibility is assumed by Analog Devices for its use, nor for any infringements of patents or other rights of third parties that may result from its use. Specifications subject to change without notice. No license is granted by implication or otherwise under any patent or patent rights of Analog Devices. Trademarks and registered trademarks are the property of their respective owners.

For price, delivery, and to place orders: Analog Devices, Inc., One Technology Way, P.O. Box 9106, Norwood, MA 02062-9106  
Phone: 781-329-4700 • Order online at [www.analog.com](http://www.analog.com)  
Application Support: Phone: 1-800-ANALOG-D



**1dB LSB GaAs MMIC 5-BIT DIGITAL  
ATTENUATOR, DC - 4 GHz**

**Evaluation Circuit Board**

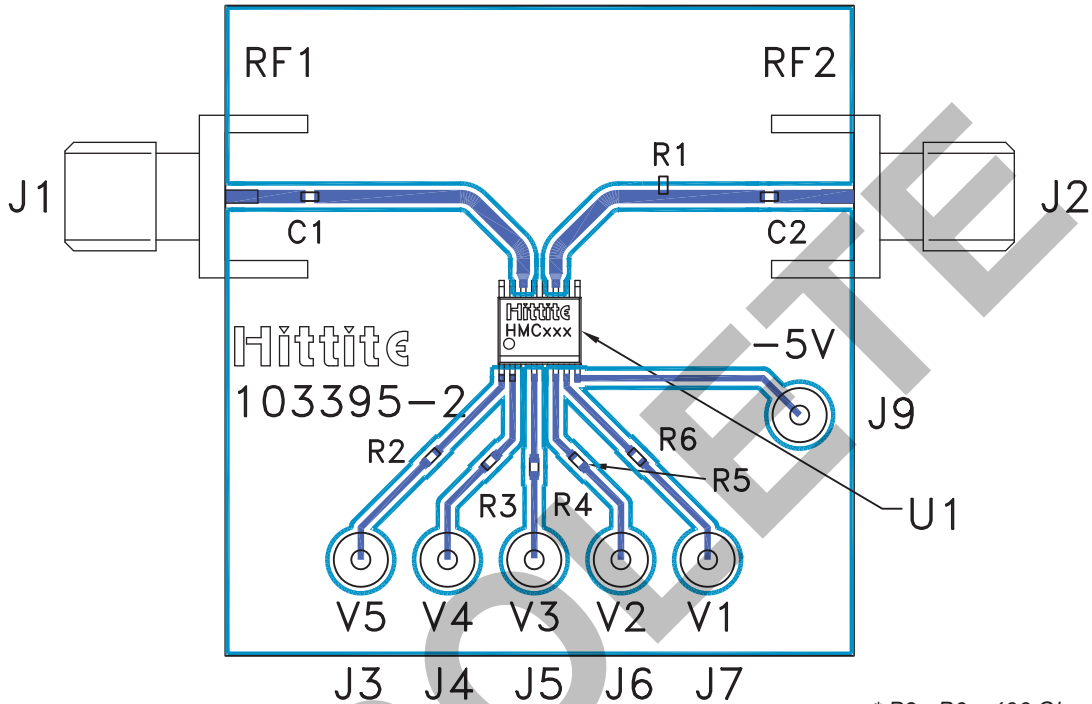

\* R2 - R6 = 100 Ohm.  
These resistors are optional and may be used to enhance decoupling of the RF path from the control inputs.

**List of Materials for Evaluation PCB 103397 [1]**

Item	Description
J1 - J2	PCB Mount SMA Connector
J3 - J9	DC Pin
R1	5k Ohm Resistor, 0402 Pkg.
R2 - R6	100 Ohm Resistor, 0402 Pkg.
C1, C2	0402 Chip Capacitor, Select Value for Lowest Frequency of Operation
U1	HMC307QS16G(E) Digital Attenuator
PCB [2]	103395 Evaluation PCB 1.5" x 1.5"

[1] Reference this number when ordering complete evaluation PCB

[2] Circuit Board Material: Rogers 4350

The circuit board used in the final application should use RF circuit design techniques. Signal lines should have 50 ohm impedance while the package ground leads and exposed paddle should be connected directly to the ground plane similar to that shown. A sufficient number of via holes should be used to connect the top and bottom ground planes. The evaluation circuit board shown is available from Hittite upon request.

**1dB LSB GaAs MMIC 5-BIT DIGITAL  
ATTENUATOR, DC - 4 GHz****Notes:**

OBSOLETE

## Looking for pricing, stock, or lifecycle information?

Click below to explore more details on WIN SOURCE:

- ⊖ [View HMC307QS16GETR on WIN SOURCE](#)
- ⊖ [Analog Devices Inc. Information](#)

## Optimize Your Supply Chain with WIN SOURCE Solutions

- ✓ Global Sourcing Solution
- ✓ Obsolete Management
- ✓ Cost Control Management
- ✓ Shortage Management
- ✓ Alternative Solution
- ✓ Excess Inventory Management