



**THE DATASHEET OF
HM16S-CALBL-001**



SynJet[®] MR16 Style Cooler 20W

SynJet cooling technology provides the most reliable thermal management solution available. This LED cooler has been developed by Aavid for cooling LED tracklights styled after MR16 halogen fixtures.

- Cools up to 20W⁴
- L10 of 100K Hours at 60°C
- Energy Efficient
- 5 Yr Warranty
- Small Form Factor
- Quiet Acoustics



Specifications¹

Thermal & Acoustic

SynJet Setting ²	Θs-a ³	TDP ⁴ (W)	SPL (dBA) ⁵	Wire Connections
High Performance	2.0	20	30	Red to +VDC Black & Blue to Ground
Standard Performance	2.65	15	19	Red to +VDC Black only to Ground
Silent Performance	3.25	12	16	Red to +VDC Black & Purple to Ground

Electrical

SynJet Setting ²	Voltage (VDC) +/- 10%	Current (mA) ⁶			Pavg (mW)	Voltage (VDC)	Current (mA) ⁶			Pavg (mW)
		Imin	Iavg	Ipeak			Imin	Iavg	Ipeak	
High Performance	5	20	116	232	580	12	10	67	134	800
Standard			126	252	630			74	148	890
Silent			48	96	240			37	74	440
PWM at 100% duty cycle			116	232	580			67	134	800

Environmental

All Settings	Min	Max	Units	Conditions
Operating Temperature	-40	70	°C	Air temperature surrounding cooler
Storage Temperature	-50	85	°C	Air temperature surrounding cooler
Storage Altitude		15K	m	Above sea level
Operating Relative Humidity	5	95	%	Non-condensing
Weight		120	g	SynJet with heatsink
Reliability		100K	hrs	L10 @ 60°C
Regulatory Compliance				RoHS, UL, FCC Part 15 Class B, CE

¹ All values are typical at 25°C unless otherwise stated.

² The Level Select model should be used for discrete performance settings. Follow the instructions in the Product Design Guide for adjusting settings.

³ Thermal resistance values are given as reference only and are measured in free air without airflow obstructions. Thermal resistance is measured from the bottom middle of the heat sink, with a heat source at least 1cm², to ambient air measured at the inlet to the SynJet. Actual thermal performance may vary by application and final product design should be tested to assure proper thermal performance.

⁴ Thermal Design Power is based on a 30°C temperature rise of heat sink mounting surface above ambient temperature around cooler.

⁵ Sound Pressure Level is measured at 1 meter distance per ISO 7779.

⁶ The SynJet has a time varying current. The current waveform is sinusoidal and the average current (Iavg) is used to calculate the average power consumption (Pavg) at nominal input voltage (VDC). See the Electrical section in the Product Design Guide for a detailed explanation.

Mechanical
SynJet Cooling Solution shown with Configurable heat sink

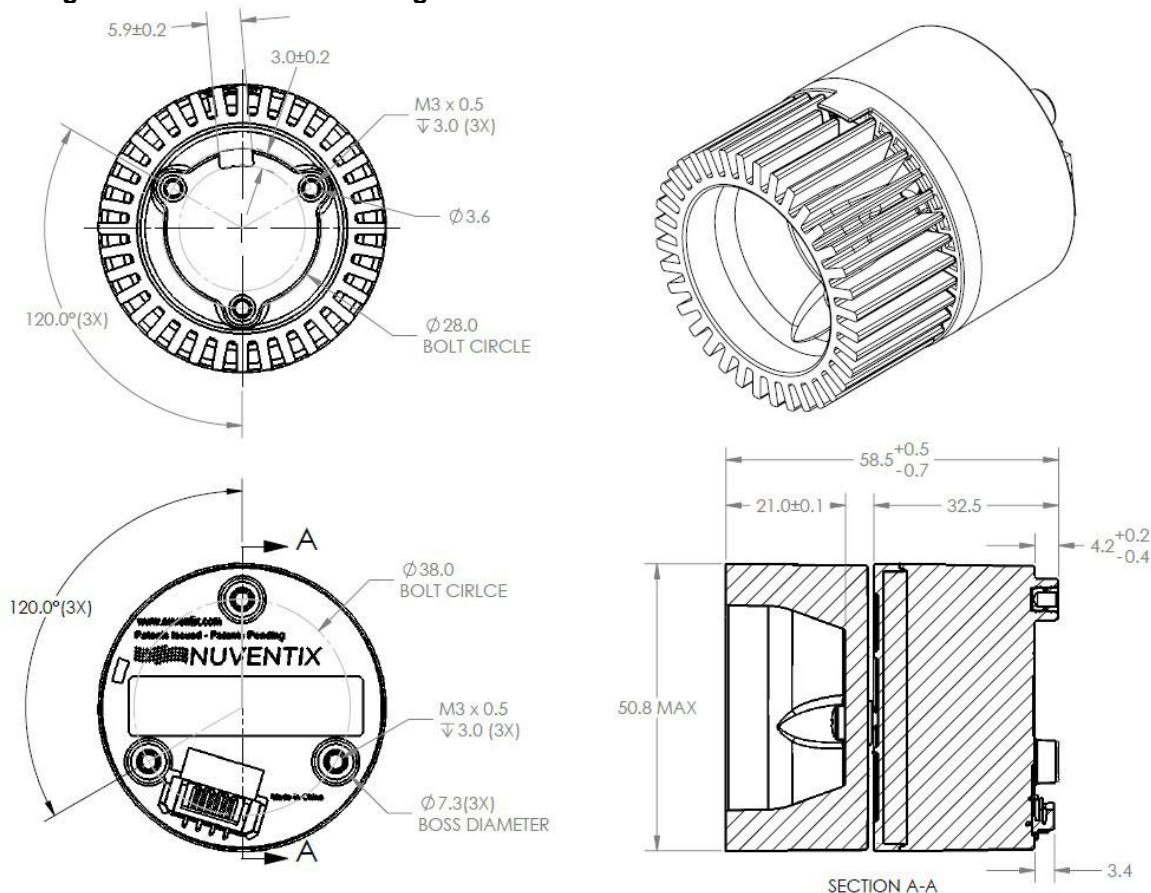

All dimensions are nominal and in mm unless otherwise stated. See product drawings for more detail.

SynJet Wire Harness

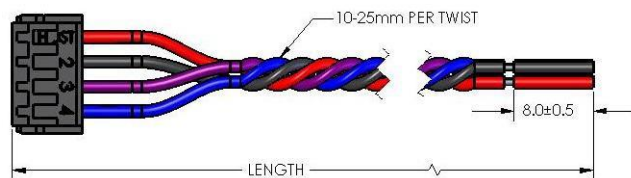

Connector Pinout

Pin	Wire Color	Symbol	Description
1	Red	+VDC	5 V or 12 V depending on model
2	Black	GND	Ground
3	Purple	CTRL2	Input for Level Select model Status signal for PWM model
4	Blue	CTRL1	Input for Level Select model PWM input for PWM model

IMPORTANT: SynJets should be completely wired to the power supply before the power supply is energized. The power supply should be turned off before the SynJet Cooler is disconnected. SynJet Coolers are not designed for “hot swap” or “hot plug” applications.

Part Numbers

Part Number	Description	Notes
SM16S-CM005-012	SynJet, ZFlow 50, Level Select, 5V	Hard wired performance settings
SM16S-CM005-010	SynJet, ZFlow 50, PWM, 5V	Use PWM input to control performance setting
SM16S-CM012-011	SynJet, ZFlow 50, Level Select, 12V	Hard wired performance settings
SM16S-CM012-012	SynJet, ZFlow 50, PWM, 12V	Use PWM input to control performance setting
HM16S-CALBL-001	Heatsink, 20W, MR16 Style, Configurable, Black	Contact sales for other heatsink options
WALLS-C4150-001	Wire Harness, 4-Wire, 150 mm Length	Contact sales for other lengths
WALLS-C4600-001	Wire Harness, 4-Wire, 600 mm Length	Contact sales for other lengths

Aavid reserves the right to make changes to the products or information contained herein without notice. No liability is assumed as a result of their use or applications. For additional information, please contact Aavid directly.

Looking for pricing, stock, or lifecycle information?

Click below to explore more details on WIN SOURCE:

- ⊖ [View HM16S-CALBL-001 on WIN SOURCE](#)
- ⊖ [Aavid Thermalloy Information](#)

Optimize Your Supply Chain with WIN SOURCE Solutions

- ✓ Global Sourcing Solution
- ✓ Obsolete Management
- ✓ Cost Control Management
- ✓ Shortage Management
- ✓ Alternative Solution
- ✓ Excess Inventory Management