



**THE DATASHEET OF
HEDS-9731#251**



Data Sheet



Description

The HEDS-973X is a high performance incremental encoder module. When operated in conjunction with either a codewheel or codestrip, this module detects rotary or linear position. The encoder consists of a lensed LED source and a detector IC enclosed in a small C-shaped plastic package. Due to a highly collimated light source and a unique photodetector array, the module is extremely tolerant to mounting misalignment.

The two channel digital outputs and 3.3V supply input are accessed through four solder plated leads located on 2.54mm (0.1inch) centers.

The standard HEDS-973X is designed for use with an appropriate optical radius codewheel or linear codestrip. Other options are available. Please contact the factory for more information.

Features

- Small Size
- High Resolution
- Two Channel Quadrature Output
- Linear and Rotary Applications
- No Signal Adjustment required
- TTL or 3.3V/5V CMOS Compatible
- Wave Solderable
- Lead-free Package
- -40°C to 85°C Operating Temperature
- Single 3.3V Supply

Applications

The HEDS-973X provides sophisticated motion detection, making closed loop control very cost competitive. Typical applications include printers, plotters, copiers and office automation equipment.

Note:
 Avago Technologies' encoders are not recommended for use in safety critical applications, e.g., ABS braking systems and critical-care medical equipment. Please contact a sales representative if more clarification is needed.

Block Diagram

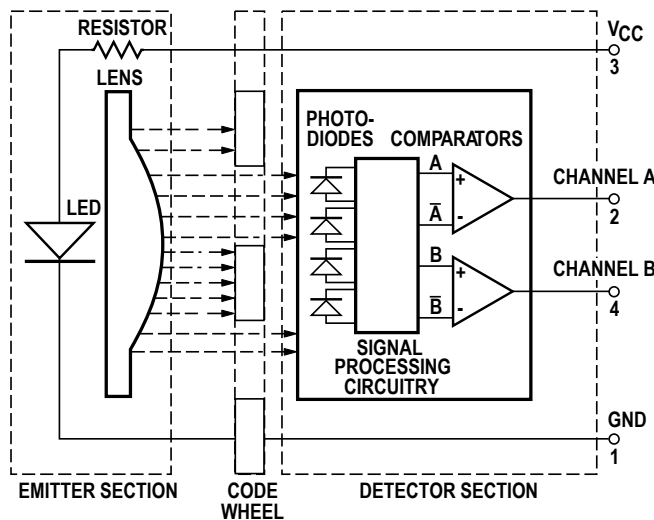

Figure 1

Theory of Operation

A HEDS-973X is a C-shaped emitter/detector module. Coupled with a codewheel, it translates rotary motion into a two-channel digital output; coupled with a codestrip, it translates linear motion into digital outputs.

As seen in Figure 1, the module contains a single Light Emitting Diode (LED) as its light source. The light is collimated into parallel beam by means of a single lens located directly over the LED. Opposite the emitter is the integrated detector circuit. This IC consists of photodetectors and a signal processing circuitry necessary to produce the digital waveforms.

The codewheel/codestrip moves between the emitter and detector, causing the light beam to be interrupted by the pattern of spaces and bars on the codewheel/codestrip. The photodiodes, which detect these interruptions, are arranged in a pattern that corresponds to the radius and count density of the codewheel/ codestrip. These photodiodes are also spaced such that a light period on one pair of detectors corresponds to a dark period on the adjacent pairs of detectors. The photodiode outputs are fed through the signal processing circuitry. Two comparators receive these signal and produce the final outputs for Channels A and B. Due to this integrated phasing technique the output of channel A is in quadrature with Channel B (90 degrees out of phase).

Output Waveforms

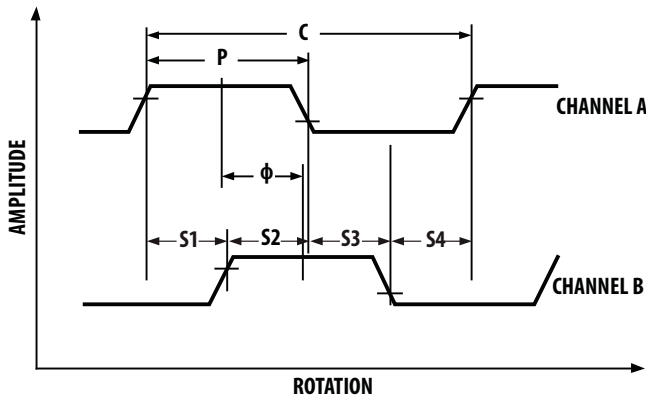

Figure 2.

Definitions

Note: Refer to Figure 2

Count (N): The number of bar and window pairs or counts per revolution (CPR) of the codewheel. Or the number of lines per inch of the codestrip (LPI)

$$1 \text{ shaft Rotation} = 360 \text{ degrees} \\ = N \text{ cycles}$$

1 cycle (c) = 360 electrical degree, equivalent to 1 bar and window pair.

Pulse Width (P): The number of electrical degrees that an output is high during one cycle, nominally 180° e or $1/2$ a cycle.

Pulse Width Error (ΔP): The deviation in electrical degrees of the pulse width from its ideal value of 180° e.

State Width (S): The number of electrical degrees between a transition in the output of channel A and the neighboring transition in the output of channel B. There are 4 states per cycle, each nominally 90° e.

State Width Error (ΔS): The deviation in electrical degrees of each state width from its ideal value of 90° e.

Phase (ϕ): The number of electrical degrees between the center of the high state on channel A and the center of the high state on channel B. This value is nominally 90° e for quadrature output.

Phase Error ($\Delta\phi$): The deviation in electrical degrees of the phase from its ideal value of 90° e.

Direction of Rotation: When the codewheel rotates in the counter-clockwise direction (as viewed from the encoder end of the motor), channel A will lead channel B. If the codewheel rotates in the clockwise direction, channel B will lead channel A.

Optical Radius (R_{op}): The distance from the codewheel's center of rotation to the optical center ($O^\circ C$) of the encoder module.

Angular Misalignment Error (E_A): Angular misalignment of the sensor in relation to then tangential direction. This applies for both rotary and linear motion.

Mounting Position (R_M): Distance from Motor Shaft center of rotation to center of Alignment Tab receiving hole.

Absolute Maximum Ratings

| Parameter | Symbol | Min. | Max. | Units | Notes |
|----------------------------|-----------|------|----------|-------|----------|
| Storage Temperature | T_S | -40 | 85 | °C | |
| Operating Temperature | T_A | -40 | 85 | °C | |
| Supply Voltage | V_{CC} | -0.5 | 7 | Volts | |
| Output Voltage | V_O | -0.5 | V_{CC} | Volts | |
| Output Current per Channel | I_{OUT} | -1.5 | 19 | mA | |
| Soldering Temperature | T_{SOL} | 20 | 260 | °C | t* 5 sec |

Recommended Operating Conditions

| Parameter | Symbol | Min. | Typ. | Max. | Units | Notes |
|----------------------|----------|------|--------------------------|------|-----------|--|
| Temperature | T_A | -40 | | 85 | °C | |
| Supply Voltage | V_{CC} | 2.8 | 3.3 or 5 | 5.2 | Volts | Ripple < 100mVp-p |
| Load Capacitance | C_L | | | 100 | pF | |
| Pull-up Resistor | R_L | | none | | | Recommend no pullup. Device has integrated 2.5 k Ω on outputs |
| Frequency | f | | | 40 | kHz | Velocity (rpm) x N/60 |
| Angular Misalignment | E_A | -2.0 | 0.0 | +2.0 | Deg. | Refer to Mounting Consideration |
| Mounting Position | R_M | | ROP-0.14 (ROP -0.006) | | Mm (inch) | Refer to Mounting Consideration |

Electrical Characteristics

Electrical Characteristics Over the Recommended Operating Conditions. Typical Values at 25°C.

| Parameter | Symbol | Min. | Typ. | Max. | Units | Notes |
|---------------------------|----------|------|----------|----------|-------|--|
| Supply Current | I_{CC} | 12 | 25 55 | 40 85 | mA | Typ. 3.3V Typ. 5V |
| High Level Output Voltage | V_{OH} | 2.4 | | | Volts | When $V_{OH} = 2.4V$ (Min)Typ. $I_{OH} = -0.4$ mA @ 3.3VTyp. $I_{OH} = -1.0$ mA @ 5V |
| Low Level Output Voltage | V_{OL} | | | 0.4 | Volts | When $V_{OL} = 0.4V$ (Max)Typ. $I_{OL} = 12$ mA @ 3.3VTyp. $I_{OL} = 14$ mA @ 5V |
| Rise Time | t_r | | 200 | | ns | $C_L = 25$ pF |
| Fall Time | t_f | | 50 | | ns | |

Encoding Characteristics

Encoding Characteristics Over the Recommended Operating Conditions and Mounting Conditions These characteristics do not include codewheel/codestrip contribution. The typical values are average over the full rotation of the codewheel

| Parameter | Symbol | Typical | Maximum | Units | Notes |
|-------------------|---------------|---------|---------|-------|-------|
| Pulse Width Error | ΔP | 5 | 50 | °e | |
| State Width Error | ΔS | 3 | 50 | °e | |
| Phase Error | $\Delta \phi$ | 2 | 15 | °e | |

Mounting Considerations

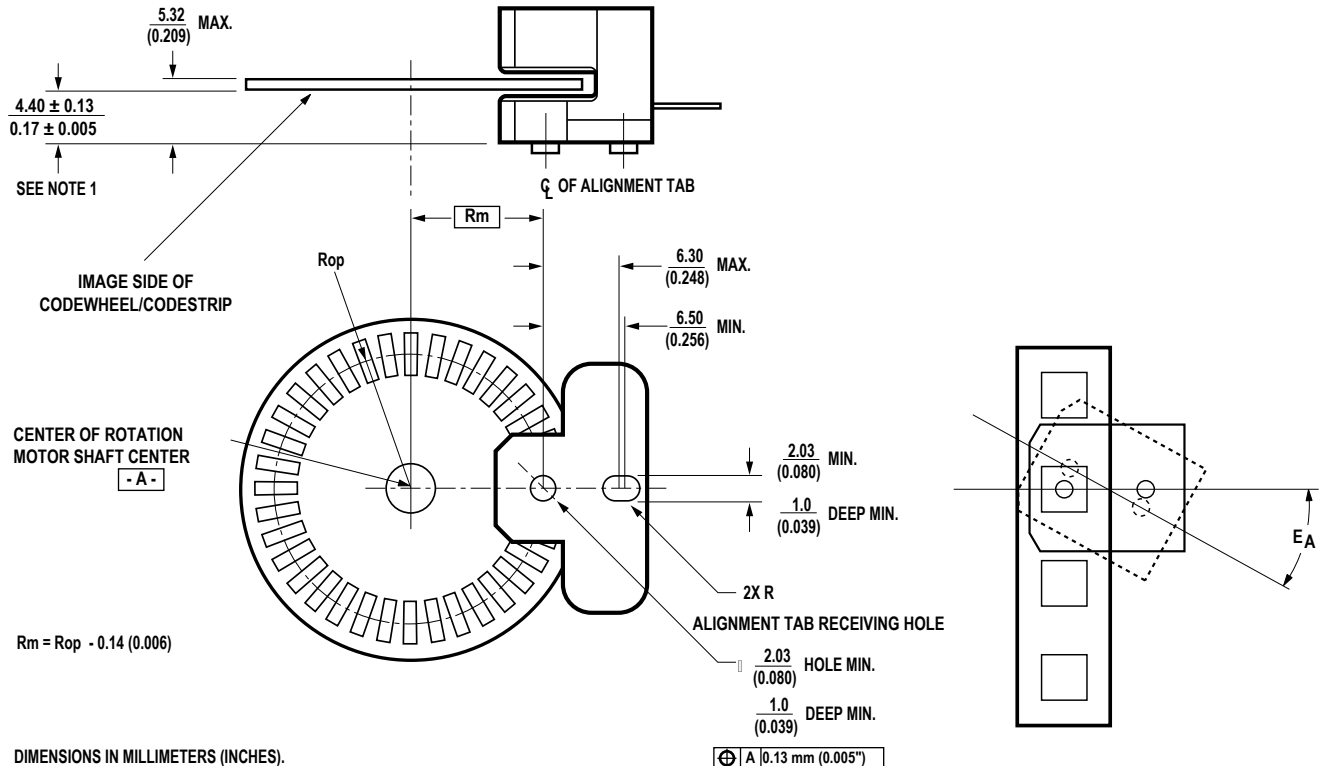

Note: These dimensions include shaft end play and codewheel warp.

For both rotary and linear motion, angular misalignment, EA must be ± 1 degrees to achieve Encoding Characteristics.

All dimension for mounting the module and codewheel/codestrip should be measured with respect to two mounting posts, as shown above

Recommended Codewheel and Codestrip Characteristics

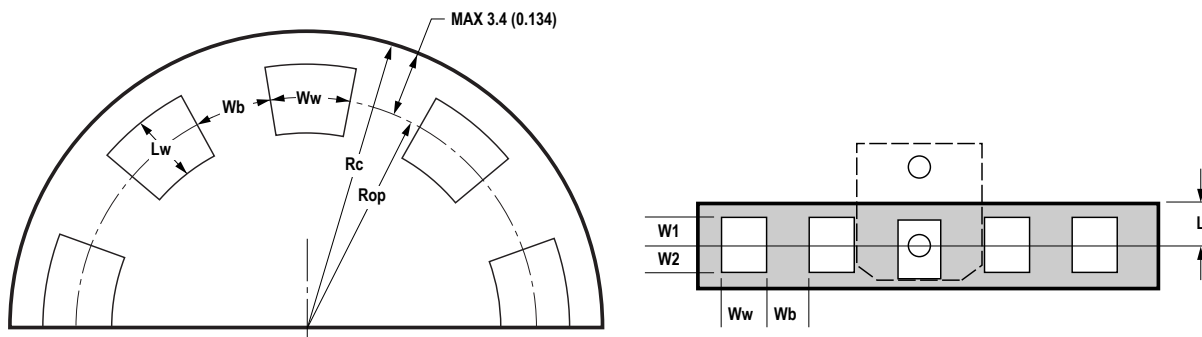

| Parameter | Symbol | Min. | Max. | Unit | Notes |
|--|--------|-----------------|-----------------------------|--------------|------------------------------|
| Window/bar Ratio | Ww/Wb | 0.9 | 1.1 | | |
| Window Length (Rotary) | LW | 1.80 (0.071) | 2.31 (0.091) | mm (inch) | |
| Absolute Maximum Codewheel Radius (Rotary) | Rc | | Rop + 3.40 (Rop + 0.134) | mm (inch) | Includes eccentricity errors |
| Center of Post to Inside Edge of Window | W1 | 1.04 (0.041) | | mm (inch) | |
| Center of Post to Outside Edge of Window | W2 | 0.76 (0.036) | | mm (inch) | |
| Center of Post to Inside Edge of Codestrip | L | | 3.60 (0.142) | mm (inch) | |

Ordering Information

HEDS - 973 Option

Lead Configurations
 0 - Straight leads
 1 - Bent leads

Resolution
 3 - 480 LPI

Bracket Option
 50

Package Dimension

Option 50

LEAD THICKNESS = 0.25 mm
 LEAD PITCH = 2.54 mm

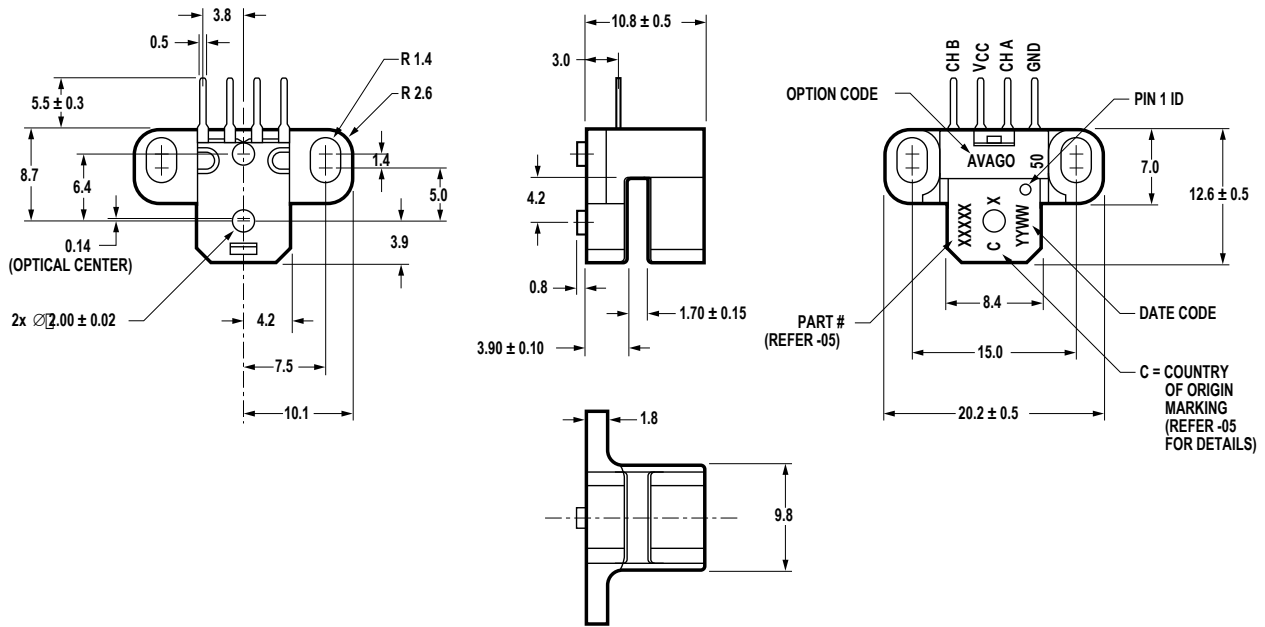

Bent Version - Option 50

LEAD THICKNESS = 0.25 mm
 LEAD PITCH = 2.54 mm

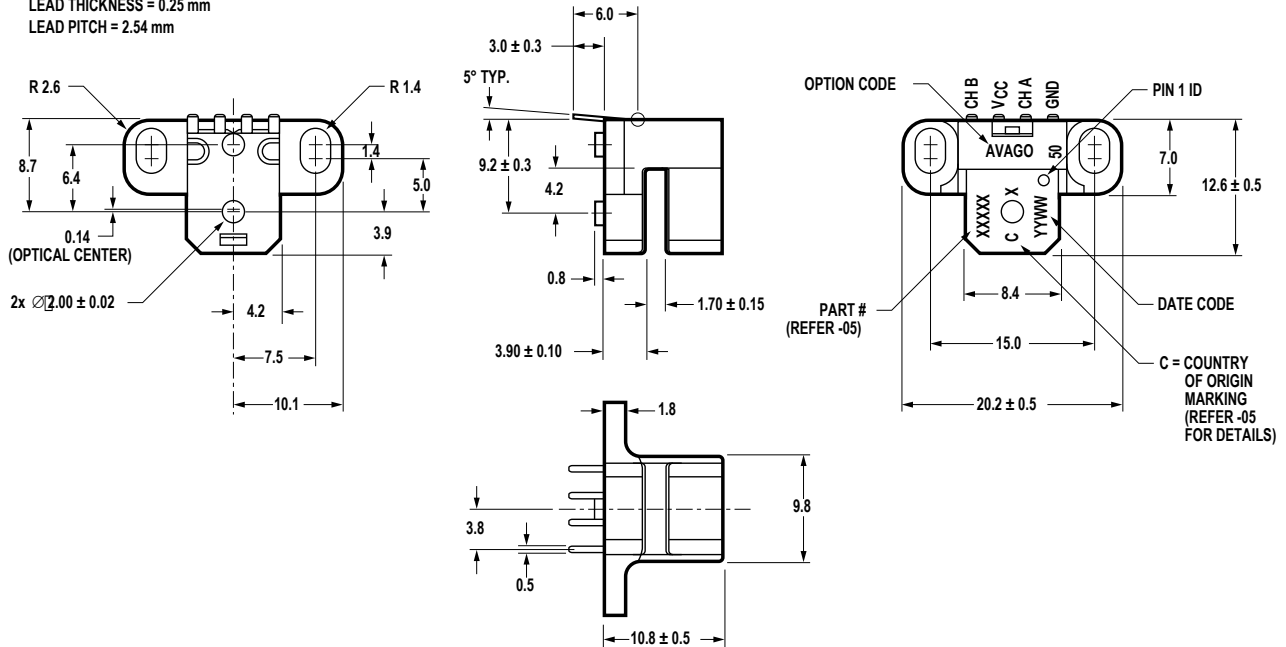

Wave Soldering Profile

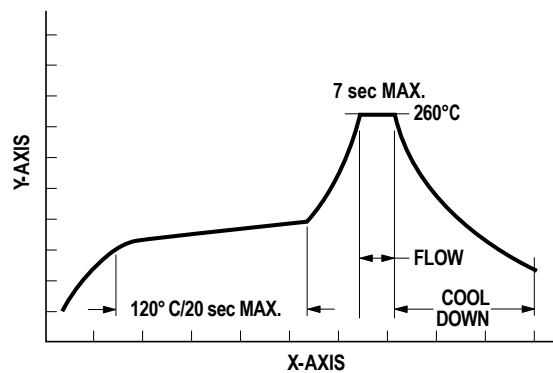

| | Parameter | Min. | Max. | Nominal values | Units |
|---|--------------------------------|------|------|----------------|-------|
| A | Solder Pot Temperature | NA | 260 | 250 - 260 | °C |
| B | Preheat Zone Temperature | 85 | 120 | 100 - 120 | °C |
| C | Dip in Time | 5 | 7 | 5 | sec |
| D | Solder Pot Zone (PCB Top) | NA | NA | NA | °C |
| E | Solder Pot Zone (Encoder Lead) | 200 | NA | ≥ 200 | °C |

For product information and a complete list of distributors, please go to our web site: www.avagotech.com

Avago, Avago Technologies, and the A logo are trademarks of Avago Technologies in the United States and other countries. Data subject to change. Copyright © 2005-2009 Avago Technologies. All rights reserved. Obsoletes 5989-0837EN AV02-1057EN - January 5, 2010

AVAGO
TECHNOLOGIES

Looking for pricing, stock, or lifecycle information?

Click below to explore more details on WIN SOURCE:

 [View HEDS-9731#251 on WIN SOURCE](#)

 [Broadcom Limited Information](#)

Optimize Your Supply Chain with WIN SOURCE Solutions

-  Global Sourcing Solution
-  Obsolete Management
-  Cost Control Management
-  Shortage Management
-  Alternative Solution
-  Excess Inventory Management