



**THE DATASHEET OF
HEDS-9041-J00**



HEDS-9040/9140

Three Channel Optical Incremental Encoder Modules



Data Sheet



Description

The HEDS-9040 and HEDS-9140 series are three channel optical incremental encoder modules. When used with a codewheel, these low cost modules detect rotary position. Each module consists of a lensed LED source and a detector IC enclosed in a small plastic package. Due to a highly collimated light source and a unique photodetector array, these modules provide the same high performance found in the HEDS-9000/9100 two channel encoder family.

Features

- Two channel quadrature output with index pulse
- Resolution up to 2000 CPR (Counts Per Revolution)
- Low cost
- Easy to mount
- No signal adjustment required
- Small size
- -40°C to 100°C operating temperature
- TTL compatible
- Single 5 V supply

Package Dimensions

HEDx-9xx0 Option

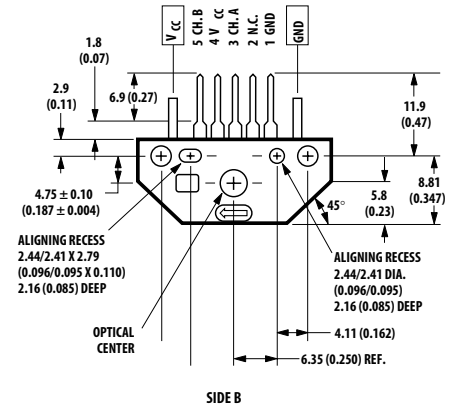
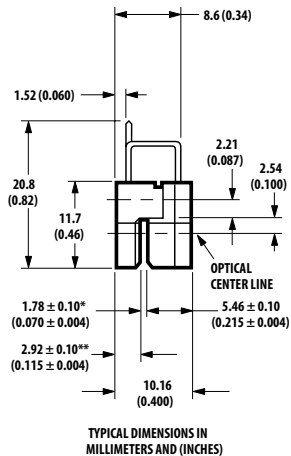
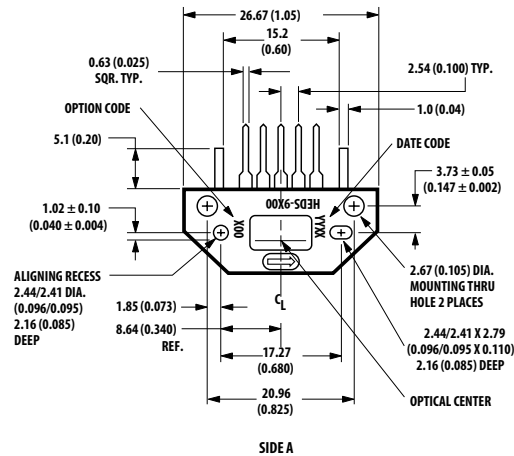

* GAP MEASUREMENT TO THE SURFACE WINDOW = 1.68 ± 0.10 (0.066 ± 0.004)
 ** HEIGHT TO THE WINDOW = 3.02 ± 0.10 (0.119 ± 0.004)

HEDx-9xx1 Option

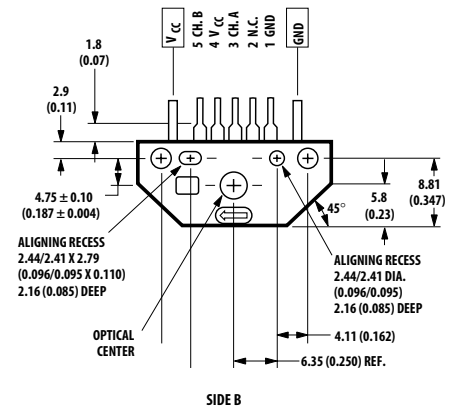
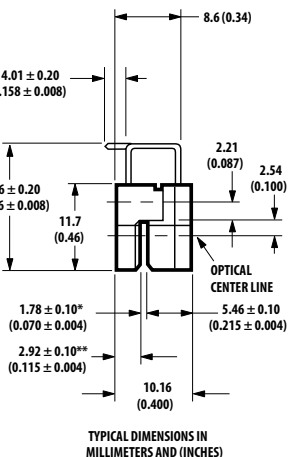
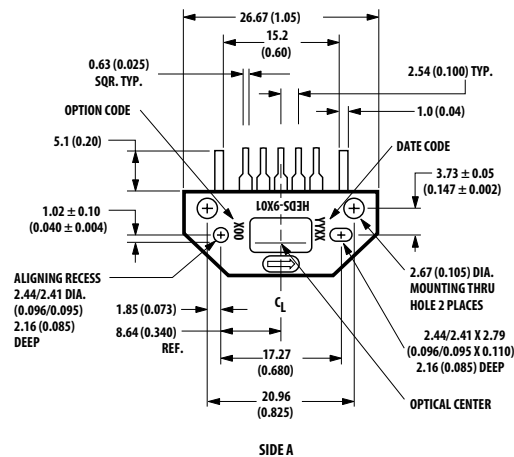

* GAP MEASUREMENT TO THE SURFACE WINDOW = 1.68 ± 0.10 (0.066 ± 0.004)
 ** HEIGHT TO THE WINDOW = 3.02 ± 0.10 (0.119 ± 0.004)

ESD WARNING: NORMAL HANDLING PRECAUTIONS SHOULD BE TAKEN TO AVOID STATIC DISCHARGE.

The HEDS-9040 and 9140 have two channel quadrature outputs plus a third channel index output. This index output is a 90 electrical degree high true index pulse which is generated once for each full rotation of the codewheel.

The HEDS-9040 is designed for use with a HEDX-614X codewheel which has an optical radius of 23.36 mm (0.920 inch). The HEDS-9140 is designed for use with a HEDx-5x4x codewheel which has an optical radius of 11.00 mm (0.433 inch).

The quadrature signals and the index pulse are accessed through five 0.025 inch square pins located on 0.1 inch centers.

Standard resolutions between 256 and 2000 counts per revolution are available. Consult local Avago sales representatives for other resolutions.

Applications

The HEDS-9040 and 9140 provide sophisticated motion control detection at a low cost, making them ideal for high volume applications. Typical applications include printers, plotters, tape drives, and industrial and factory automation equipment.

Note: Avago Technologies encoders are not recommended for use in safety critical applications. Eg. ABS braking systems, power steering, life support systems and critical care medical equipment. Please contact sales representative if more clarification is needed.

Theory of Operation

The HEDS-9040 and 9140 are emitter/detector modules. Coupled with a codewheel, these modules translate the rotary motion of a shaft into a three-channel digital output.

As seen in the block diagram, the modules contain a single Light Emitting Diode (LED) as its light source. The light is collimated into a parallel beam by means of a single polycarbonate lens located directly over the LED. Opposite the emitter is the integrated detector circuit. This IC consists of multiple sets of photodetectors and the signal processing circuitry necessary to produce the digital waveforms.

The codewheel rotates between the emitter and detector, causing the light beam to be interrupted by the pattern of spaces and bars on the codewheel. The photodiodes which detect these interruptions are arranged in a pattern that corresponds to the radius and design of the codewheel. These detectors are also spaced such that a light period on one pair of detectors corresponds to a dark period on the adjacent pair of detectors. The photodiode outputs are then fed through the signal processing circuitry resulting in A , \bar{A} , B , \bar{B} , I and \bar{I} . Comparators receive these signals and produce the final outputs for channels A and B. Due to this integrated phasing technique, the digital output of channel A is in quadrature with that of channel B (90 degrees out of phase).

The output of the comparator for I and \bar{I} is sent to the index processing circuitry along with the outputs of channels A and B. The final output of channel I is an index pulse P_o which is generated once for each full rotation of the codewheel. This output P_o is a one state width (nominally 90 electrical degrees), high true index pulse which is coincident with the low states of channels A and B.

Block Diagram

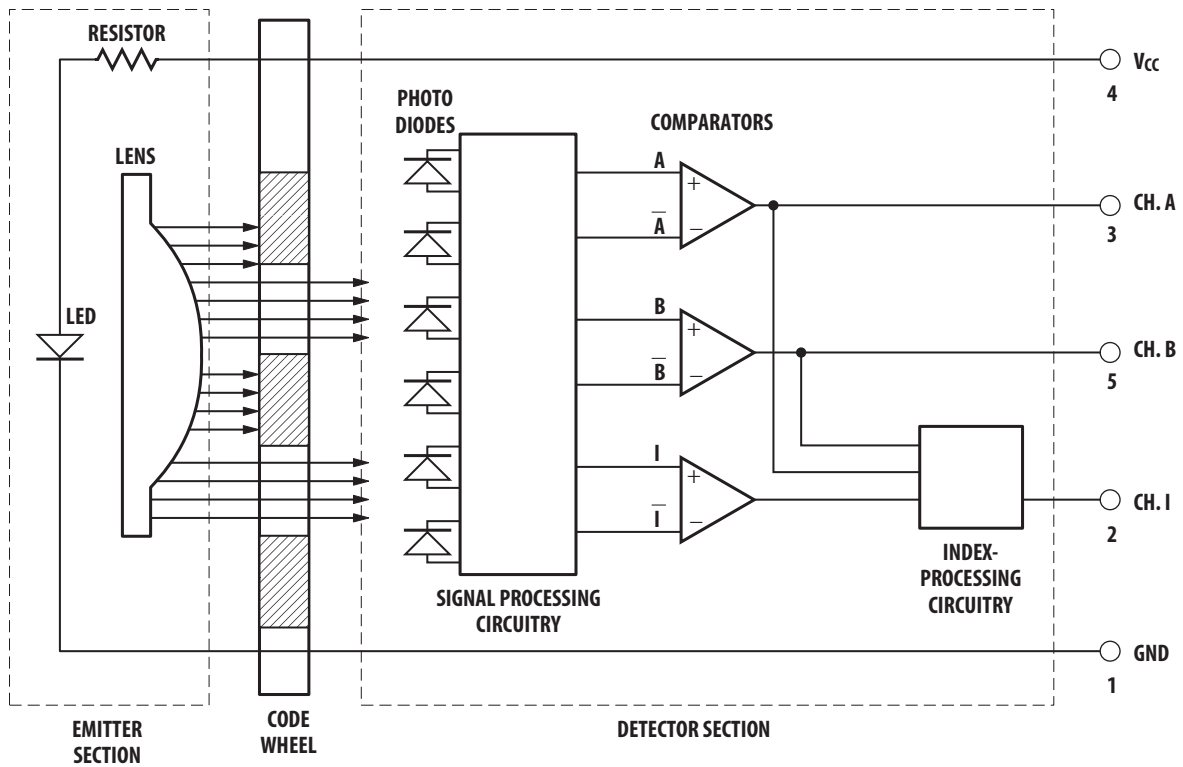

Output Waveforms

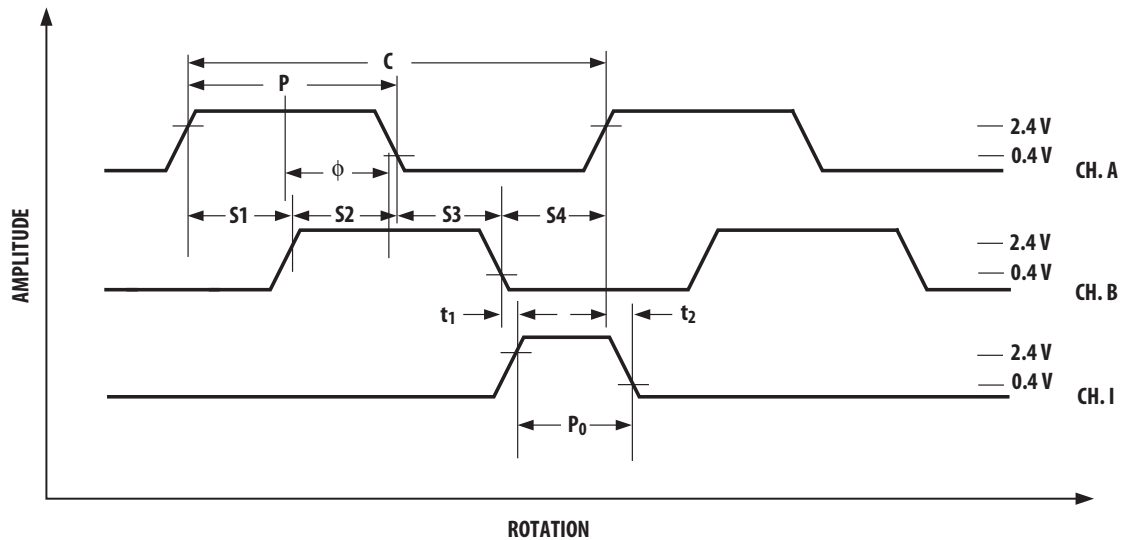

Definitions

Count (N): The number of bar and window pairs or counts per revolution (CPR) of the codewheel.

One Cycle (C): 360 electrical degrees ($^{\circ}e$), 1 bar and window pair.

One Shaft Rotation: 360 mechanical degrees, N cycles.

Position Error ($\Delta\theta$): The normalized angular difference between the actual shaft position and the position indicated by the encoder cycle count.

Cycle Error (ΔC): An indication of cycle uniformity. The difference between an observed shaft angle which gives rise to one electrical cycle, and the nominal angular increment of $1/N$ of a revolution.

Pulse Width (P): The number of electrical degrees that an output is high during 1 cycle. This value is nominally $180^{\circ}e$ or $1/2$ cycle.

Pulse Width Error (ΔP): The deviation, in electrical degrees, of the pulse width from its ideal value of $180^{\circ}e$.

State Width (S): The number of electrical degrees between a transition in the output of channel A and the

neighboring transition in the output of channel B. There are 4 states per cycle, each nominally $90^{\circ}e$.

State Width Error (ΔS): The deviation, in electrical degrees, of each state width from its ideal value of $90^{\circ}e$.

Phase (ϕ): The number of electrical degrees between the center of the high state of channel A and the center of the high state of channel B. This value is nominally $90^{\circ}e$ for quadrature output.

Phase Error ($\Delta\phi$): The deviation of the phase from its ideal value of $90^{\circ}e$.

Direction of Rotation: When the codewheel rotates in the direction of the arrow on top of the module, channel A will lead channel B. If the codewheel rotates in the opposite direction, channel B will lead channel A.

Optical Radius (R_{op}): The distance from the codewheel's center of rotation to the optical center (O.C.) of the encoder module.

Index Pulse Width (P_o): The number of electrical degrees that an index is high during one full shaft rotation. This value is nominally $90^{\circ}e$ or $1/4$ cycle.

Absolute Maximum Ratings

Storage Temperature, T_s	-40°C to +100°C
Operating Temperature, T_A	-40°C to +100°C
Supply Voltage, V_{CC}	-0.5 V to 7 V
Output Voltage, V_o	-0.5 V to V_{CC}
Output Current per Channel, I_{OUT}	-1.0 mA to 5 mA
Shaft Axial Play	± 0.25 mm (± 0.010 in.)
Shaft Eccentricity Plus Radial Play	0.1 mm (0.004 in.) TIR
Velocity	30,000 RPM ^[1]
Acceleration	250,000 rad/sec ² [1]

Note:

1. Absolute maximums for HEDS-5140/6140 codewheels only.

Recommended Operating Conditions

Parameter	Symbol	Min.	Typ.	Max.	Units	Notes
Temperature	T_A	-40		100	°C	
Supply Voltage	V_{CC}	4.5	5.0	5.5	Volts	Ripple < 100 mV _{p-p}
Load Capacitance	C_L			100	pF	2.7 kΩ pull-up
Count Frequency	f			100	kHz	Velocity (rpm) x N/60
Shaft Perpendicularity				±0.25	mm	6.9 mm (0.27 in.) from
Plus Axial Play				(±0.010)	(in.)	mounting surface
Shaft Eccentricity Plus				0.04	mm (in.)	6.9 mm (0.27 in.) from
Radial Play				(0.0015)	TIR	mounting surface

Note: The module performance is guaranteed to 100 kHz but can operate at higher frequencies. For the HEDS-9040 #T00 for operation below 0°C and greater than 50 kHz the maximum Pulse Width and Logic State Width errors are 60°e.

Encoding Characteristics

HEDS-9040 (except #T00), HEDS-9140 (except #B00)

Encoding Characteristics over Recommended Operating Range and Recommended Mounting Tolerances unless otherwise specified. Values are for the worst error over the full rotation of HEDS-5140 and HEDS-6140 codewheels.

Parameter		Symbol	Min.	Typ. ^[1]	Max.	Units
Cycle Error		ΔC		3	5.5	°e
Pulse Width Error		ΔP		7	30	°e
Logic State Width Error		ΔS		5	30	°e
Phase Error		$\Delta\phi$		2	15	°e
Position Error		$\Delta\Theta$		10	40	min. of arc
Index Pulse Width		P_o	60	90	120	°e
CH. I rise after	-25°C to +100°C	t_1	10	100	250	ns
CH. B or CH. A fall	-40°C to +100°C	t_1	-300	100	250	ns
CH. I fall after	-25°C to +100°C	t_2	70	150	300	ns
CH. A or CH. B rise	-40°C to +100°C	t_2	70	150	1000	ns

Note:

1. Module mounted on tolerance circle of ±0.13 mm (±0.005 in.) radius referenced from module Side A aligning recess centers. 2.7 kΩ pull-up resistors used on all encoder module outputs.

Encoding Characteristics

HEDS-9040 #T00

Encoding Characteristics over Recommended Operating Range and Recommended Mounting Tolerances unless otherwise specified. Values are for the worst error over the full rotation of HEDM-614X Option TXX codewheel.

Parameter	Symbol	Min.	Typ. ^[1]	Max.	Units	
Cycle Error	ΔC		3	7.5	°e	
Pulse Width Error	ΔP		7	50	°e	
Logic State Width Error	ΔS		5	50	°e	
Phase Error	$\Delta \phi$		2	15	°e	
Position Error	$\Delta \Theta$		2	20	min. of arc	
Index Pulse Width	P_o	40	90	140	°e	
CH. I rise after CH. B or CH. A fall	t_1	-40°C to +100°C	10	450	1500	ns
CH. I fall after CH. A or CH. B rise	t_2	-40°C to +100°C	10	250	1500	ns

Note:

1. Module mounted on tolerance circle of ± 0.13 mm (± 0.005 in.) radius referenced from module Side A aligning recess centers. 2.7 k Ω pull-up resistors used on all encoder module outputs.

Encoding Characteristic

HEDS-9140 #B00

Encoding Characteristics over Recommended Operating Range and Recommended Mounting Tolerances unless otherwise specified. Values are for the worst error over the full rotation of HEDM-504X Option BXX codewheel.

Parameter	Symbol	Min.	Typ. ^[1]	Max.	Units	
Cycle Error	ΔC		6	12	°e	
Pulse Width Error	ΔP		10	45	°e	
Logic State Width Error	ΔS		10	45	°e	
Phase Error	$\Delta \Phi$		2	15	°e	
Position Error	$\Delta \Theta$		10	40	min. of arc	
Index Pulse Width	P_o	50	90	130	°e	
CH. I Rise after CH B or CH A fall	t_1	-40°C to +100°	200	1000	1500	ns
CH. I fall after CH. A or CH.B rise	t_2	-40°C to +100°	0	300	1500	ns

Note:

1. Module mounted on tolerance circle of ± 0.13 mm (± 0.005 in.) radius referenced from module Side A aligning recess centers. 2.7 k Ω pull-up resistors used on all encoder module outputs.

Electrical Characteristics

Electrical Characteristics over Recommended Operating Range.

Parameter	Symbol	Min.	Typ. ^[1]	Max.	Units	Notes
Supply Current	I_{CC}	30	57	85	mA	
High Level Output Voltage	V_{OH}	2.4			V	$I_{OH} = -200 \mu A$ max.
Low Level Output Voltage	V_{OL}			0.4	V	$I_{OL} = 3.86$ mA
Rise Time	t_r		180 ^[2]		ns	$C_L = 25$ pF $R_L = 2.7$ k Ω pull-up
Fall Time	t_f		49 ^[2]		ns	

Notes:

1. Typical values specified at $V_{CC} = 5.0$ V and 25°C.
2. t_r and t_f 80 nsec for HEDS-9040 #T00.

Electrical Interface

To insure reliable encoding performance, the HEDS-9040 and 9140 three channel encoder modules require 2.7 k Ω ($\pm 10\%$) pull-up resistors on output pins 2, 3, and 5 (Channels I, A and B) as shown in Figure 1. These pull-up resistors should be located as close to the encoder module as possible (within 4 feet). Each of the three encoder module outputs can drive a single TTL load in this configuration.

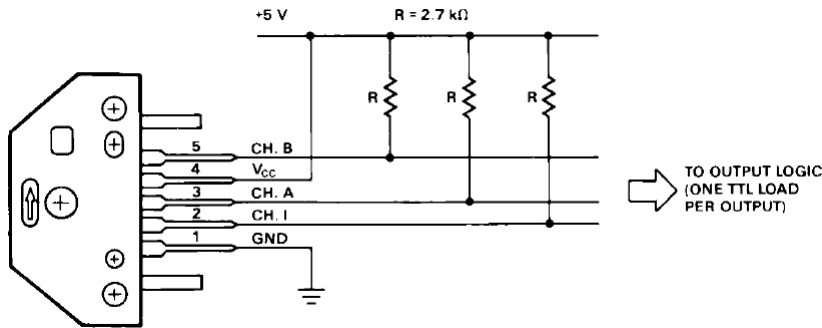

Figure 1. Pull-up Resistors on HEDS-9X40 Encoder Module Outputs.

Mounting Considerations

Figure 2 shows a mounting tolerance *requirement* for proper operation of the HEDS-9040 and HEDS-9140. The Aligning Recess Centers must be located within a tolerance circle of 0.005 in. radius from the nominal locations. This tolerance must be maintained whether the module is mounted with side A as the mounting plane using aligning pins (see Figure 5), or mounted with Side B as the mounting plane using an alignment tool (see Figures 3 and 4).

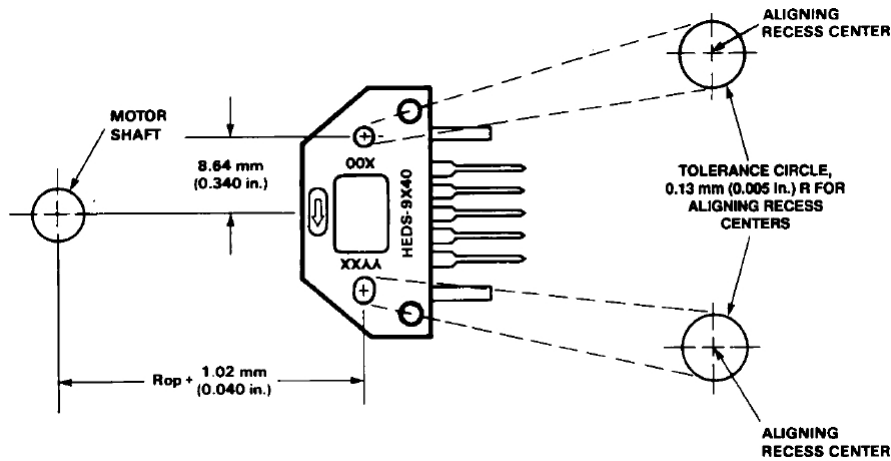

Figure 2. HEDS-9X40 Mounting Tolerance.

Mounting with an Alignment Tool

The HEDS-8905 and HEDS-8906 alignment tools are recommended for mounting the modules with Side B as the mounting plane. The HEDS-8905 is used to mount the HEDS-9140, and the HEDS-8906 is used to mount the HEDS-9040. These tools fix the module position using the codewheel hub as a reference. They will not work if Side A is used as the mounting plane.

The following assembly procedure uses the HEDS-8905/8906 alignment tool to mount a HEDS-9140/9040 module and a HEDS-5140/6140 codewheel:

Instructions:

1. Place codewheel on shaft.
2. Set codewheel height by placing alignment tool on motor base (pins facing up) flush up against the codewheel as shown in Figure 3. Tighten codewheel setscrew and remove alignment tool.
3. Insert mounting screws through module and thread into the motor base. Do not tighten screws.
4. Slide alignment tool over codewheel hub and onto module as shown in Figure 4. The pins of the alignment tool should fit snugly inside the alignment recesses of the module.
5. While holding alignment tool in place, tighten screws down to secure module.
6. Remove alignment tool.

Mounting with Aligning Pins

The HEDS-9040 and HEDS-9140 can also be mounted using aligning pins on the motor base. (Hewlett-Packard does not provide aligning pins.) For this configuration, Side A must be used as the mounting plane. The aligning recess centers must be located within the 0.005 in. R Tolerance Circle as explained above. Figure 5 shows the necessary dimensions.

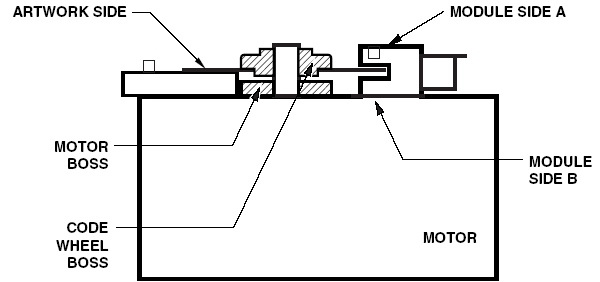

Figure 3. Alignment Tool is Used to Set Height of Codewheel.

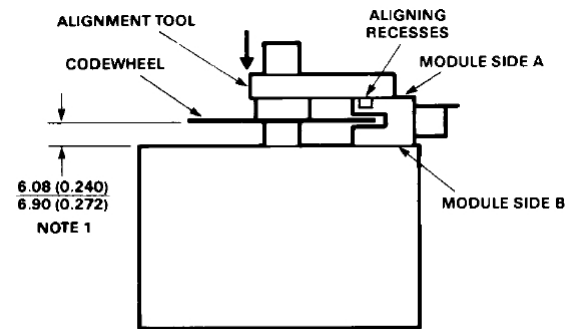

Figure 4. Alignment Tool is Placed over Shaft and onto Codewheel Hub. Alignment Tool Pins Mate with Aligning Recesses on Module.

Mounting with Aligning Pins

The HEDS-9040 and HEDS-9140 can also be mounted using aligning pins on the motor base. (Avago does not provide aligning pins.) For this configuration, Side A must be used as the mounting plane. The aligning recess

centers must be located within the 0.005 in. Radius Tolerance Circle as explained in "Mounting Considerations." Figure 5 shows the necessary dimensions.

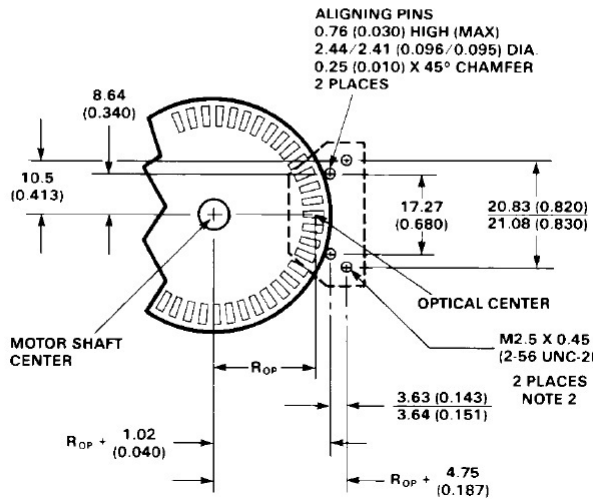
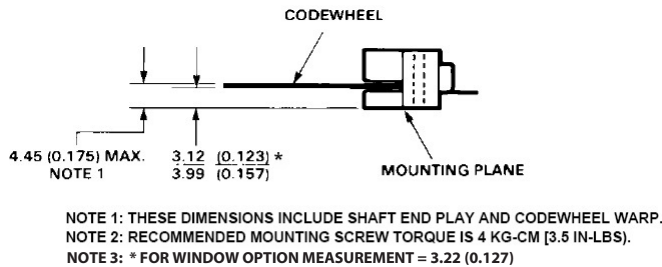

Figure 5. Mounting Plane Side A.

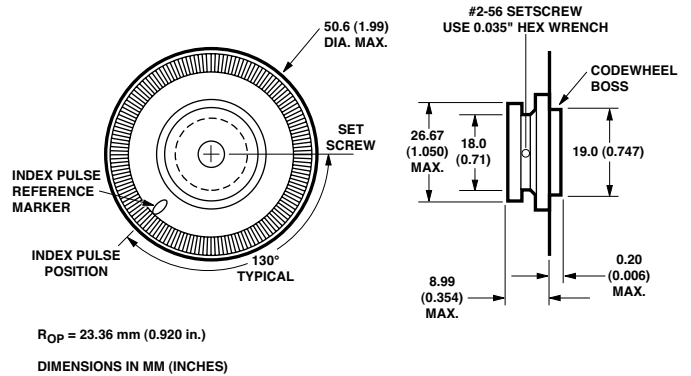

Figure 6a. HEDS-6140 Codewheel Used with HEDS-9040.

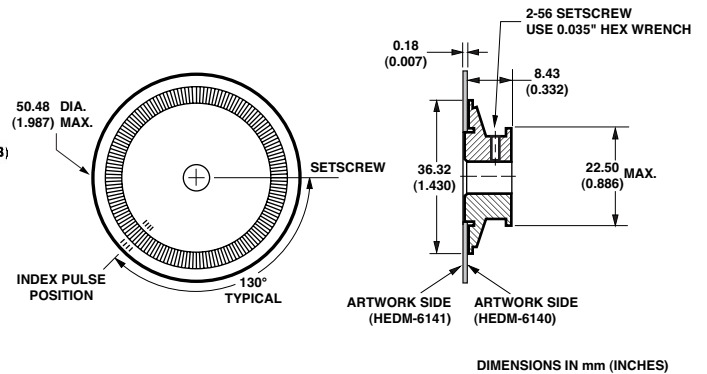

Figure 6b. HEDM-614X Series Codewheel used with HEDS-9040 #T00.

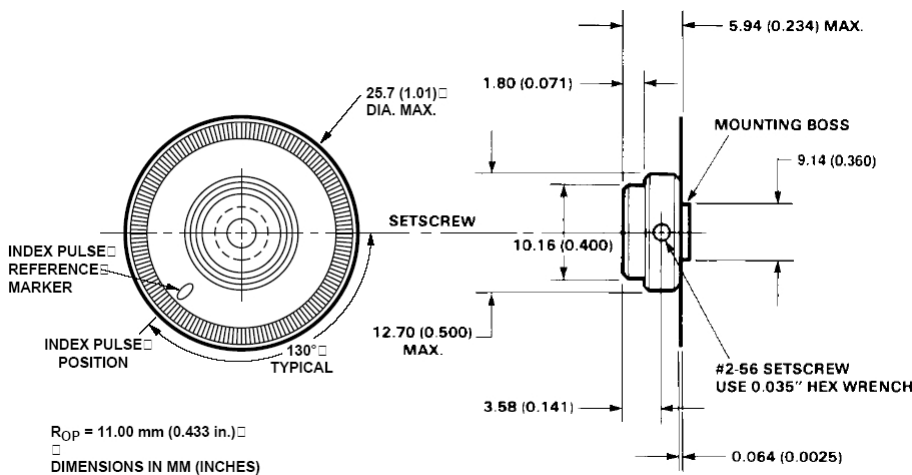

Figure 7. HEDS-5140 Codewheel Used with HEDS-9140.

Orientation of Artwork for HEDS-9040 Option T00 (2000 CPR, 23.36mm Rop) and HEDS-9140 Option B00 (1000CPR, 11.00mm Rop)

The Index area on the HEDS- 9040 Option T00, 2000 CPR and HEDS-9140 Option B00, 1000 CPR Encoder Module has a nonsymmetrical pattern as does the mating Codewheel. In order for the Index to operate, the “Rightreading” side of the Codewheel disk (the “Artwork Side”) must point toward “Side A” of the Module (the side with the connecting pins).

Because the Encoder Module may be used with either “Side A” or with “Side B” toward the

Mounting Surface, Avago supplies two versions of Film Codewheels for use with the Option T00 3-channel Module and Option B00 3-Channel Module: Codewheel HEDM-6140 Option TXX and HEDM-5040 Option Bxx has the Artwork Side on the “Hub Side” of the Codewheel/hub assembly and works with “Side B” of the Module on the user’s mounting surface. Codewheel HEDM-6141 Option TXX and HEDM-5041-Bxx has the Artwork Side opposite the “Hub Side” and works with “Side A” of the Module on the mounting surface. For the Index to operate, these parts must be oriented as shown in Figure 7a and 7b.

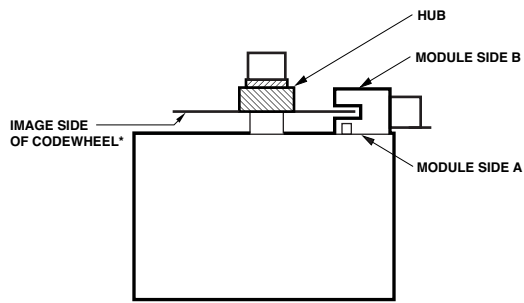

* USE HEDM-6141#Txx or HEDM-5041#Bxx

Figure 7a.

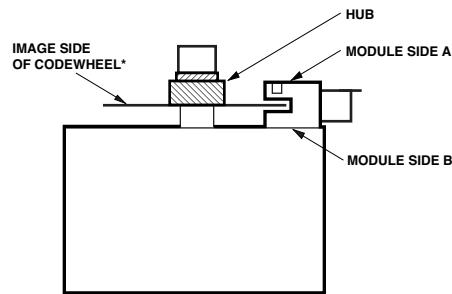

* USE HEDM-6140#Txx or HEDM-5040#Bxx

Figure 7b.

*Please note that the image side of the codewheel must always be facing the module Side A.

Connectors

Manufacturer	Part Number
AMP	103686-4
	640442-5
Avago	HEDS-8902 (2 ch.) with 4-wire leads
	HEDS-8903 (3 ch.) with 5-wire leads
Molex	2695 series with 2759 series term.

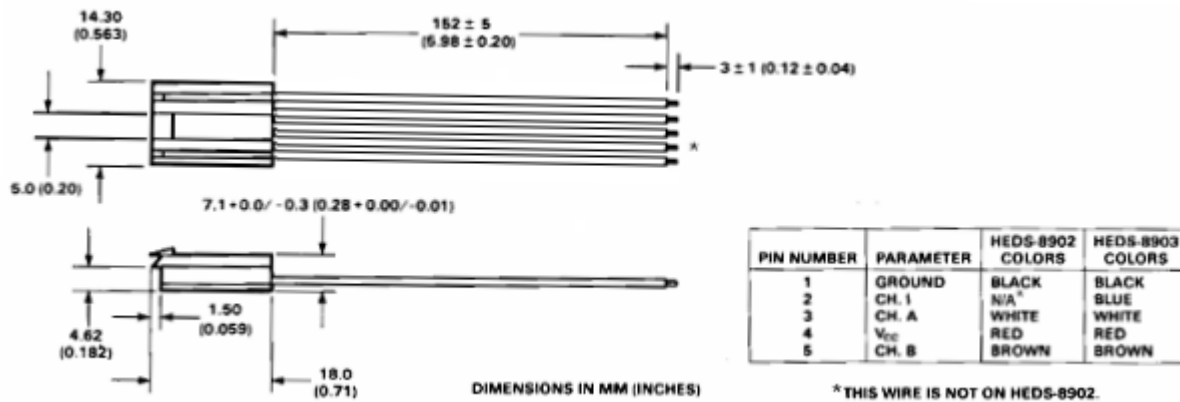
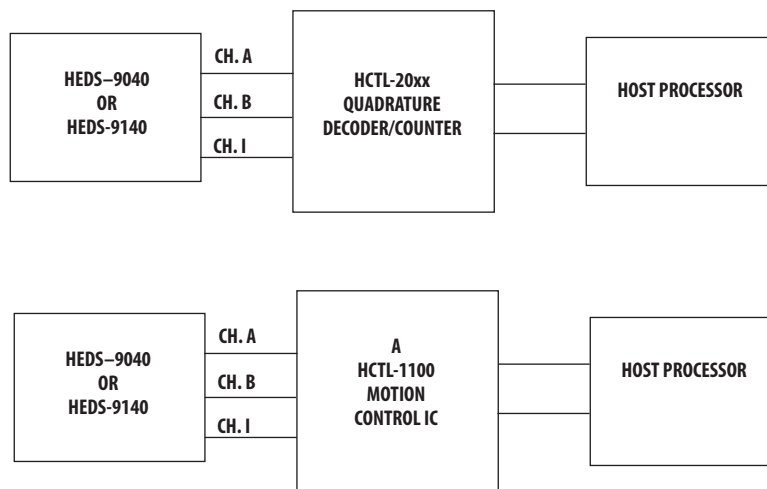

Figure 8. HEDS-8903 Connector.

Typical Interfaces



Ordering Information

Three Channel Encoder Modules and Codewheels, 23.36 mm Optical Radius.

HEDS-904 0 Option 0 0

Lead Bend
0 - Straight Leads
1 - Bent Leads

HEDS-6140 Option

Resolution (Cycles/Rev)
B - 1000 CPR
J - 1024 CPR

Shaft Diameter	
06 - 1/4 in.	11 - 4 mm
08 - 3/8 in.	12 - 6 mm
09 - 1/2 in.	13 - 8 mm
10 - 5/8 in.	

Assembly Tool

HEDS-8906

Three Channel Encoder Modules and Codewheels, 23.36 mm Optical Radius

HEDS-9040 Option 0 0

Resolution (Cycles/Rev)
T - 2000 CPR

HEDM-614

Artwork Orientation
0 - Artwork on hub side (use when module Side B is down)
1 - Artwork opposite hub side (use when Module Side A is down)

Option

Shaft Diameter
12 - 6 mm

Assembly Tool

HEDS-8906

	A	B	C	D	E	F	G	H	I	J	K	S	T	U
HEDS-9040	*									*			*	
HEDS-9041	*													

	01	02	03	04	05	06	08	09	10	11	12	13	14
HEDS-6140	B						*	*	*	*	*	*	*
	J						*		*			*	*
HEDM-6140	T											*	

Three Channel Encoder Modules and Codewheels, 11.00 mm Optical Radius

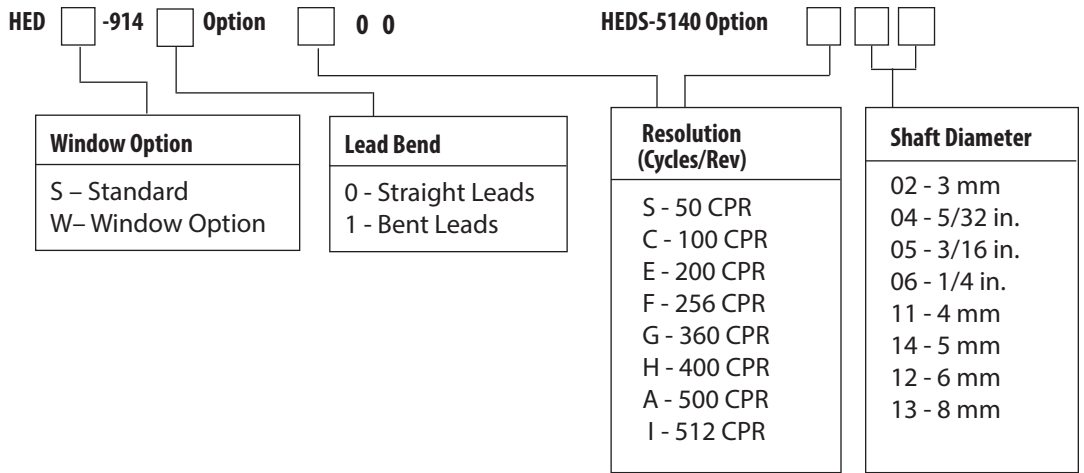

Assembly Tool

HEDS-8905

Three Channel Encoder Modules and Codewheels, 11.000 Optical Radius

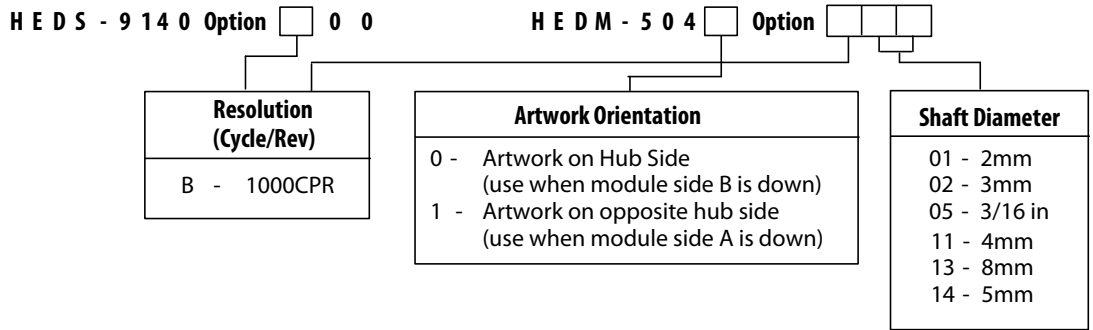

Assembly Tool

HEDS-8905

	A	B	C	D	E	F	G	H	I	J	K	S	T	U
HEDS-9140	*	*	*		*	*	*	*	*		*			
HEDS-9141	*				*	*	*							
HEDW-9140	*								*					

		01	02	03	04	05	06	08	09	10	11	12	13	14
HEDS-5140	A		*		*	*	*				*	*	*	*
	C				*		*					*	*	
	E						*				*	*		*
	F				*							*		*
	G							*				*		*
	I		*		*		*					*	*	*
HEDM-5040	B	*	*			*					*		*	*
HEDM-5041	B	*	*			*					*		*	*

For product information and a complete list of distributors, please go to our website: www.avagotech.com

Avago, Avago Technologies, and the A logo are trademarks of Avago Technologies in the United States and other countries. Data subject to change. Copyright © 2005-2014 Avago Technologies. All rights reserved. Obsoletes 5988-5498EN AV02-1132EN - March 17, 2014



Looking for pricing, stock, or lifecycle information?

Click below to explore more details on WIN SOURCE:

 [View HEDS-9041-J00 on WIN SOURCE](#)

 [Broadcom Limited](#) Information

Optimize Your Supply Chain with WIN SOURCE Solutions

-  Global Sourcing Solution
-  Obsolete Management
-  Cost Control Management
-  Shortage Management
-  Alternative Solution
-  Excess Inventory Management