

HCPL0600, HCPL0601, HCPL0611, HCPL0630, HCPL0631, HCPL0661 High Speed-10 MBit/s Logic Gate Optocouplers

Single Channel: HCPL0600, HCPL0601, HCPL0611
Dual Channel: HCPL0630, HCPL0631, HCPL0661

Features

- Compact SO8 package
- Very high speed-10 MBit/s
- Superior CMR
- Fan-out of 8 over -40°C to +85°C
- Logic gate output
- Strobable output (single channel devices)
- Wired OR-open collector
- U.L. recognized (File # E90700)
- VDE approval pending

- Switching power supplies
- Pulse transformer replacement
- Computer-peripheral interface

Description

The HCPL06XX optocouplers consist of an AlGaAs LED, optically coupled to a very high speed integrated photo-detector logic gate with a strobable output (single channel devices). The devices are housed in a compact small-outline package. This output features an open collector, thereby permitting wired OR outputs. The HCPL0600, HCPL0601 and HCPL0611 output consists of bipolar transistors on a bipolar process while the HCPL0630, HCPL0631, and HCPL0661 output consists of bipolar transistors on a CMOS process for reduced power consumption. The coupled parameters are guaranteed over the temperature range of -40°C to +85°C. A maximum input signal of 5 mA will provide a minimum output sink current of 13 mA (fan out of 8). An internal noise shield provides superior common mode rejection.

Applications

- Ground loop elimination
- LSTTL to TTL, LSTTL or 5-volt CMOS
- Line receiver, data transmission
- Data multiplexing

Package Dimensions

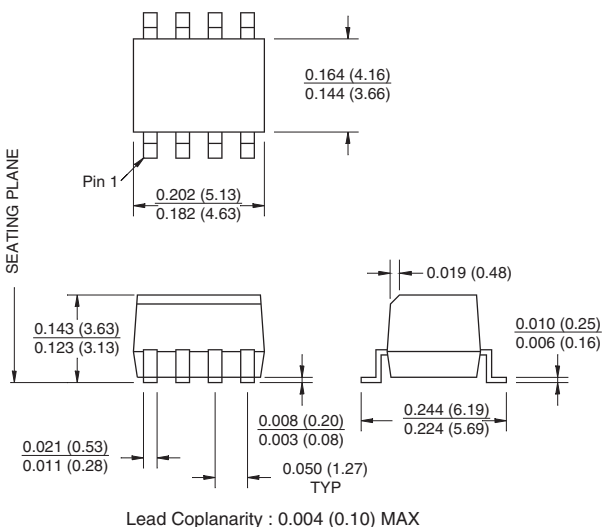

NOTE

All dimensions are in inches (millimeters)

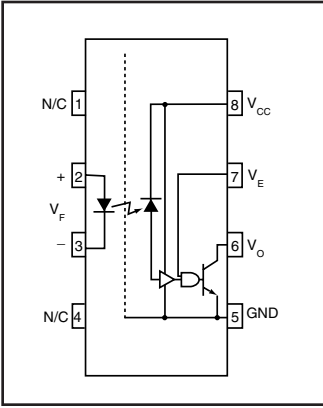

Single-channel circuit drawing (HCPL0600, HCPL0601 and HCPL0611)

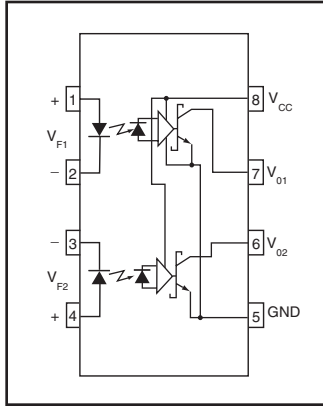

Dual-channel circuit drawing (HCPL0630, HCPL0631 and HCPL0661)

TRUTH TABLE (Positive Logic)

Input	Enable	Output
H	H	L
L	H	H
H	L	H
L	L	H
H*	NC*	L*
L*	NC*	H*

*Dual channel devices or single channel devices with pin 7 not connected.
 A 0.1 μ F bypass capacitor must be connected between pins 8 and 5. (See note 1)

Absolute Maximum Ratings (No derating required up to 85°C)

Symbol	Parameter		Value	Units
T _{STG}	Storage Temperature		-40 to +125	°C
T _{OPR}	Operating Temperature		-40 to +85	°C
EMITTER				
I _F	DC/Average Forward Input Current (each channel)	Single Channel	50	mA
		Dual Channel		
V _E	Enable Input Voltage Not to exceed V _{CC} by more than 500mV	Single Channel	5.5	V
V _R	Reverse Input Voltage (each channel)		5.0	V
P _I	Power Dissipation	Single Channel	45	mW
		Dual Channel		
DETECTOR				
V _{CC} (1 minute max)	Supply Voltage		7.0	V
I _O	Output Current (each channel)		50	mA
V _O	Output Voltage (each channel)		7.0	V
P _O	Collector Output Power Dissipation	Single Channel	85	mW
		Dual Channel		

Recommended Operating Conditions

Symbol	Parameter	Min	Max	Units
I _{FL}	Input Current, Low Level	0	250	μA
I _{FH}	Input Current, High Level	*6.3	15	mA
V _{CC}	Supply Voltage, Output	4.5	5.5	V
V _{EL}	Enable Voltage, Low Level	0	0.8	V
V _{EH}	Enable Voltage, High Level	2.0	V _{CC}	V
T _A	Operating Temperature	-40	+85	°C
N	Fan Out (TTL load)		8	TTL Loads
R _L	Output Pull-up	330	4K	Ω

*6.3 mA is a guard banded value which allows for at least 20% CTR degradation. Initial input current threshold value is 5.0 mA or less

Electrical Characteristics ($T_A = -40^\circ\text{C}$ to $+85^\circ\text{C}$ Unless otherwise specified.)

Individual Component Characteristics

Symbol	Parameter	Test Conditions	Min	Typ**	Max	Unit
V_F	EMITTER Input Forward Voltage	($I_F = 10\text{ mA}$)			1.8	V
		$T_A = 25^\circ\text{C}$			1.75	
B_{VR}	Input Reverse Breakdown Voltage	($I_R = 10\ \mu\text{A}$)	5.0			V
C_{IN}	Input Capacitance	($V_F = 0, f = 1\text{ MHz}$)				pF
$\Delta V_F/\Delta T_A$	Input Diode Temperature Coefficient	($I_F = 10\text{ mA}$)				mV/ $^\circ\text{C}$
I_{CCH}	DETECTOR High Level Supply Current	($V_E = 0.5\text{ V}$)	Single Channel		10	mA
		($I_F = 0\text{ mA}, V_{CC} = 5.5\text{ V}$)	Dual Channel		15	
I_{CCL}	Low Level Supply Current	($V_E = 0.5\text{ V}$)	Single Channel		13	mA
		($I_F = 10\text{ mA}, V_{CC} = 5.5\text{ V}$)	Dual Channel		21	
I_{EL}	Low Level Enable Current	($V_{CC} = 5.5\text{ V}, V_E = 0.5\text{ V}$)	Single Channel		-1.6	mA
I_{EH}	High Level Enable Current	($V_{CC} = 5.5\text{ V}, V_E = 2.0\text{ V}$)	Single Channel		-1.6	mA
V_{EH}	High Level Enable Voltage	($V_{CC} = 5.5\text{ V}, I_F = 10\text{ mA}$)	Single Channel	2.0		V
V_{EL}	Low Level Enable Voltage	($V_{CC} = 5.5\text{ V}, I_F = 10\text{ mA}$)(Note 2)	Single Channel		0.8	V

Switching Characteristics ($T_A = -40^\circ\text{C}$ to $+85^\circ\text{C}$, $V_{CC} = 5\text{ V}$, $I_F = 7.5\text{ mA}$ Unless otherwise specified.)

Symbol	AC Characteristics	Test Conditions	Device	Min	Typ	Max	Unit	
T_{PLH}	Propagation Delay Time to Output High Level	(Note 3) ($T_A = 25^\circ\text{C}$)	All	20		75	ns	
		($R_L = 350\ \Omega, C_L = 15\text{ pF}$) (Fig. 20)				100		
T_{PHL}	Propagation Delay Time to Output Low Level	(Note 4) ($T_A = 25^\circ\text{C}$)	All	25		75	ns	
		($R_L = 350\ \Omega, C_L = 15\text{ pF}$) (Fig. 20)				100		
$ T_{PHL} - T_{PLH} $	Pulse Width Distortion	($R_L = 350\ \Omega, C_L = 15\text{ pF}$) (Fig. 20)	All			35	ns	
t_r	Output Rise Time (10-90%)	($R_L = 350\ \Omega, C_L = 15\text{ pF}$)(Note 5) (Fig. 20)	All		50		ns	
t_f	Output Fall Time (90-10%)	($R_L = 350\ \Omega, C_L = 15\text{ pF}$)(Note 6) (Fig. 20)	All		12		ns	
t_{ELH}	Enable Propagation Delay Time to Output High Level	(I _F = 7.5 mA, V _{EH} = 3.5 V) ($R_L = 350\ \Omega, C_L = 15\text{ pF}$) (Note 7) (Fig. 21)	HCPL0600		20		ns	
			HCPL0601					
			HCPL0611					
t_{EHL}	Enable Propagation Delay Time to Output Low Level	(I _F = 7.5 mA, V _{EH} = 3.5 V) ($R_L = 350\ \Omega, C_L = 15\text{ pF}$) (Note 8) (Fig. 21)	HCPL0600		20		ns	
			HCPL0601					
			HCPL0611					
$ ICM_H $	Common Mode Transient Immunity (at Output High Level)	(R _L = 350 Ω) ($T_A = 25^\circ\text{C}$) (I _F = 0 mA, V _{OH} (Min.) = 2.0 V)(Note 9)(Fig. 22, 23)	V _{CM} = 10 V	HCPL0600			V/ μs	
				HCPL0630				
			V _{CM} = 50 V	HCPL0601	5000			
				HCPL0631				
$ ICM_H $	Common Mode Transient Immunity (at Output Low Level)	(R _L = 350 Ω) ($T_A = 25^\circ\text{C}$) (I _F = 7.5 mA, V _{OL} (Max.) = 0.8 V)(Note 10)(Fig. 22, 23)	V _{CM} = 10 V	HCPL0600			V/ μs	
				HCPL0630				
			V _{CM} = 50 V	HCPL0601	5000			
				HCPL0631				
$ ICM_H $	Common Mode Transient Immunity (at Output Low Level)	(R _L = 350 Ω) ($T_A = 25^\circ\text{C}$) (I _F = 7.5 mA, V _{OL} (Max.) = 0.8 V)(Note 10)(Fig. 22, 23)	V _{CM} = 1,000 V	HCPL0611	10,000		V/ μs	
				HCPL0661	25,000			

Transfer Characteristics ($T_A = -40^\circ\text{C}$ to $+85^\circ\text{C}$ Unless otherwise specified.)

Symbol	DC Characteristics	Test Conditions	Min	Typ**	Max	Unit
I_{OH}	High Level Output Current	($V_{CC} = 5.5\text{ V}$, $V_O = 5.5\text{ V}$) ($I_F = 250\ \mu\text{A}$, $V_E = 2.0\text{ V}$) (Note 2)			100	μA
V_{OL}	Low Level Output Voltage	($V_{CC} = 5.5\text{ V}$, $I_F = 5\text{ mA}$) ($V_E = 2.0\text{ V}$, $I_{OL} = 13\text{ mA}$) (Note 2)			0.6	V
I_{FT}	Input Threshold Current	($V_{CC} = 5.5\text{ V}$, $V_O = 0.6\text{ V}$, $V_E = 2.0\text{ V}$, $I_{OL} = 13\text{ mA}$)			5	mA

Isolation Characteristics ($T_A = -40^\circ\text{C}$ to $+85^\circ\text{C}$ Unless otherwise specified.)

Symbol	Characteristics	Test Conditions	Min	Typ**	Max	Unit
I_{I-O}	Input-Output Insulation Leakage Current	(Relative humidity = 45%) ($T_A = 25^\circ\text{C}$, $t = 5\text{ s}$) ($V_{I-O} = 3000\text{ VDC}$) (Note 11)			1.0*	μA
V_{ISO}	Withstand Insulation Test Voltage	($R_H < 50\%$, $T_A = 25^\circ\text{C}$) ($I_{I-O} \leq 2\ \mu\text{A}$, $t = 1\text{ min.}$) (Note 11)	3750			V_{RMS}
R_{I-O}	Resistance (Input to Output)	($V_{I-O} = 500\text{ V}$) (Note 11)		10^{12}		Ω
C_{I-O}	Capacitance (Input to Output)	($f = 1\text{ MHz}$) (Note 11)		0.6		pF

** All typical values are at $V_{CC} = 5\text{ V}$, $T_A = 25^\circ\text{C}$

NOTES

1. The V_{CC} supply to each optoisolator must be bypassed by a $0.1\ \mu\text{F}$ capacitor or larger. This can be either a ceramic or solid tantalum capacitor with good high frequency characteristic and should be connected as close as possible to the package V_{CC} and GND pins of each device.
2. Enable Input - No pull up resistor required as the device has an internal pull up resistor.
3. t_{PLH} - Propagation delay is measured from the 3.75 mA level on the HIGH to LOW transition of the input current pulse to the 1.5V level on the LOW to HIGH transition of the output voltage pulse.
4. t_{PHL} - Propagation delay is measured from the 3.75 mA level on the LOW to HIGH transition of the input current pulse to the 1.5V level on the HIGH to LOW transition of the output voltage pulse.
5. t_r - Rise time is measured from the 90% to the 10% levels on the LOW to HIGH transition of the output pulse.
6. t_f - Fall time is measured from the 10% to the 90% levels on the HIGH to LOW transition of the output pulse.
7. t_{ELH} - Enable input propagation delay is measured from the 1.5V level on the HIGH to LOW transition of the input voltage pulse to the 1.5V level on the LOW to HIGH transition of the output voltage pulse.
8. t_{EHL} - Enable input propagation delay is measured from the 1.5V level on the LOW to HIGH transition of the input voltage pulse to the 1.5V level on the HIGH to LOW transition of the output voltage pulse.
9. CM_H - The maximum tolerable rate of rise of the common mode voltage to ensure the output will remain in the high state (i.e., $V_{OUT} > 2.0\text{ V}$). Measured in volts per microsecond ($\text{V}/\mu\text{s}$).
10. CM_L - The maximum tolerable rate of fall of the common mode voltage to ensure the output will remain in the low output state (i.e., $V_{OUT} < 0.8\text{ V}$). Measured in volts per microsecond ($\text{V}/\mu\text{s}$).
11. Device considered a two-terminal device: Pins 1,2,3 and 4 shorted together, and Pins 5,6,7 and 8 shorted together.

Typical Performance Curves (HCPL0600, HCPL0601 and HCPL0611 only)

Fig. 1 Forward Current vs. Input Forward Voltage

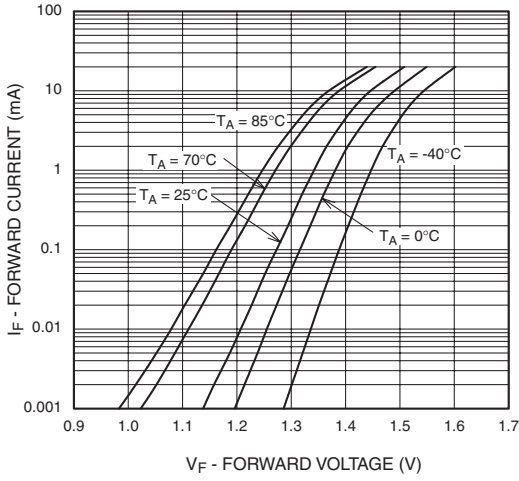

Fig. 2 Output Voltage vs. Forward Current

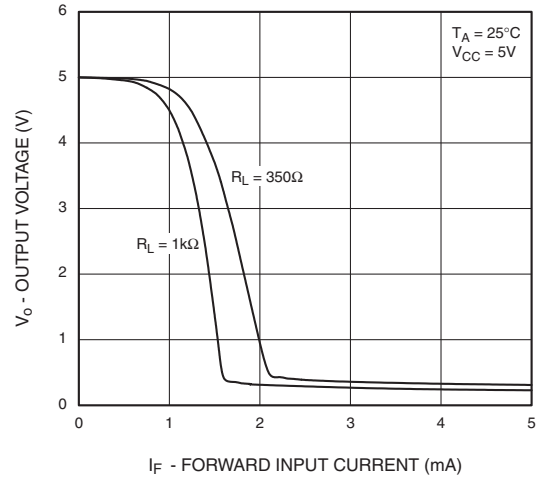

Fig. 3 Input Threshold Current vs. Temperature

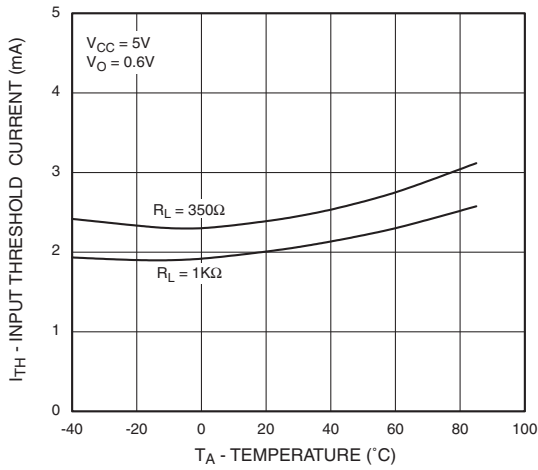
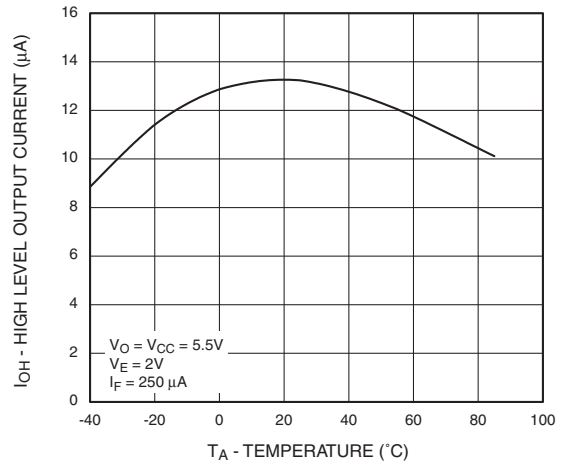

Fig. 4 High Level Output Current vs. Temperature



Typical Performance Curves (HCPL0600, and HCPL0601 and HCPL0611 only)

Fig. 5 Low Level Output Voltage vs. Temperature

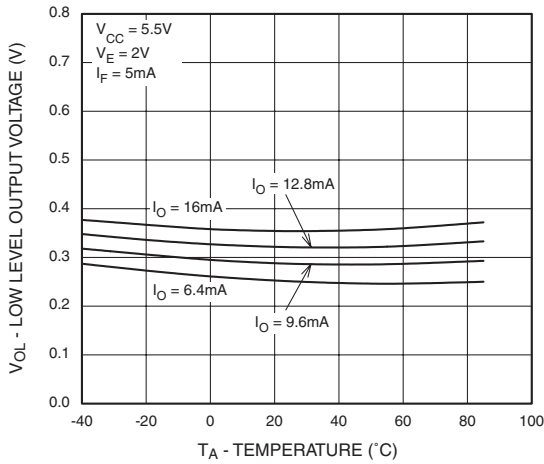

Fig. 6 Low Level Output Current vs. Temperature

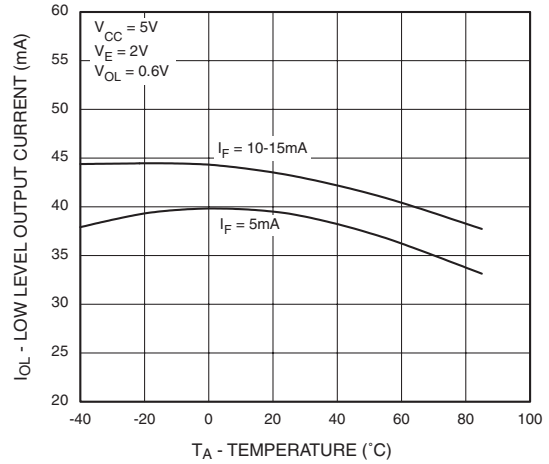

Fig. 7 Propagation Delay vs. Temperature

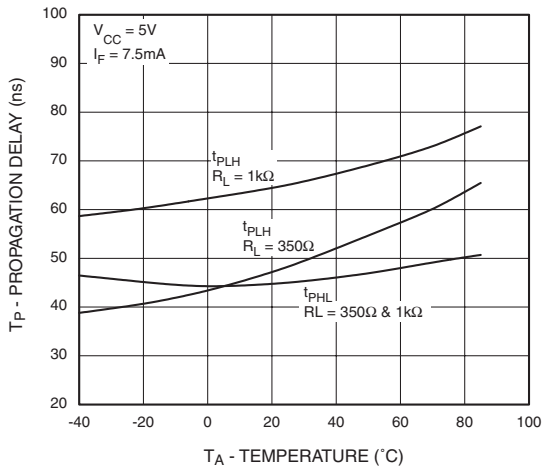
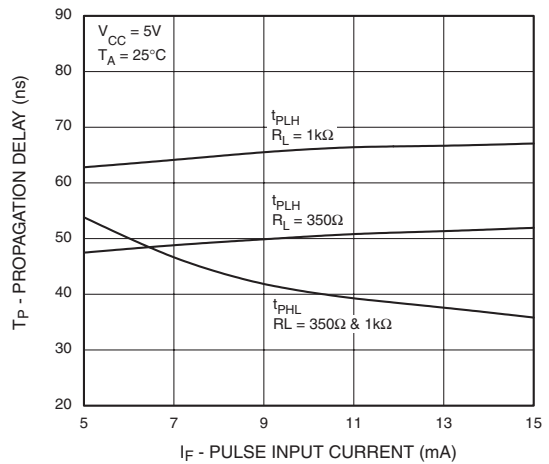

Fig. 8 Propagation Delay vs. Pulse Input Current



Typical Performance Curves (HCPL0600, HCPL0601 and HCPL0611 only)

Fig. 9 Typical Enable Propagation Delay vs. Temperature

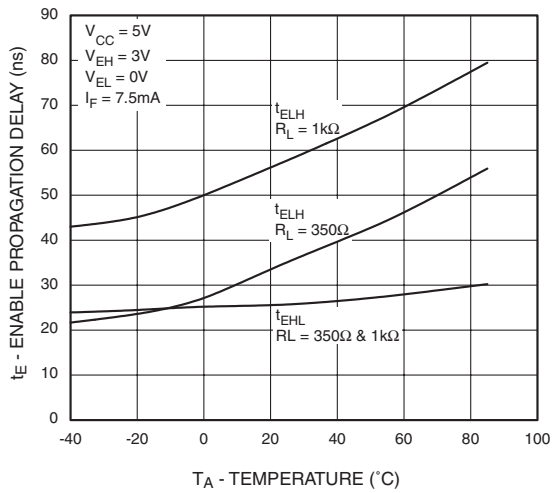

Fig. 10 Typical Rise and Fall Time vs. Temperature

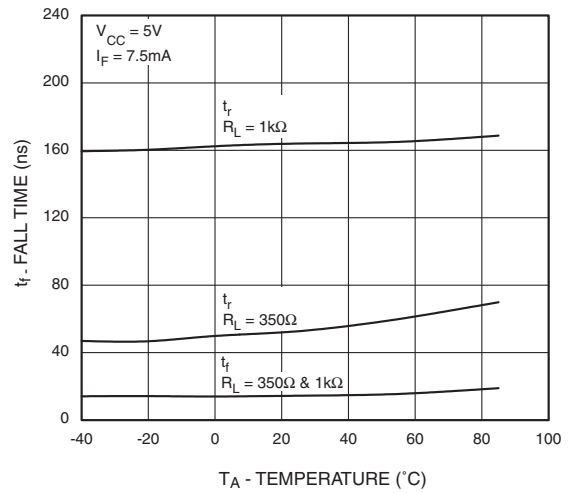
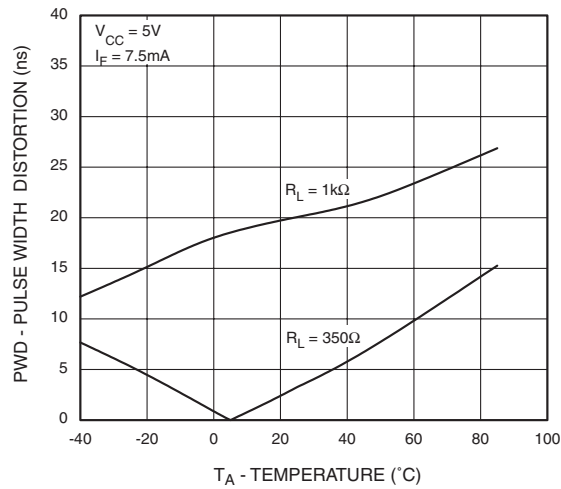

Fig. 11 Typical Pulse Width Distortion vs. Temperature



Typical Performance Curves (HCPL0630, HCPL0631 and HCPL0661 only)

Fig. 12 Input Forward Current vs. Forward Voltage

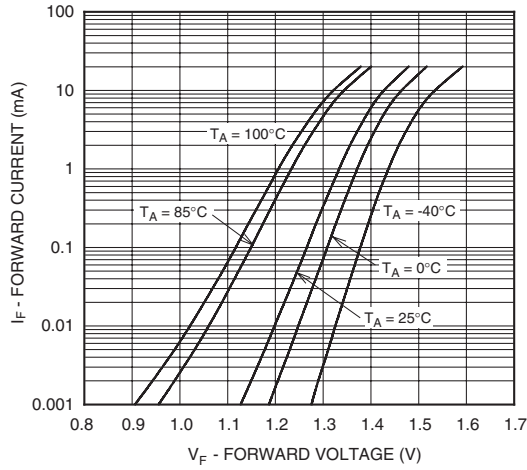

Fig. 13 Input Threshold Current vs. Ambient Temperature

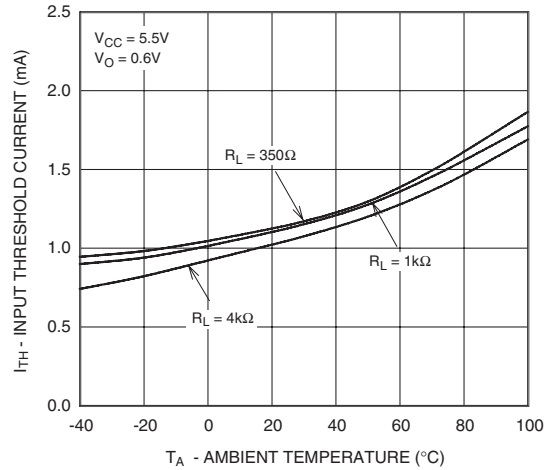

Fig. 14 High Level Output Current vs. Ambient Temperature

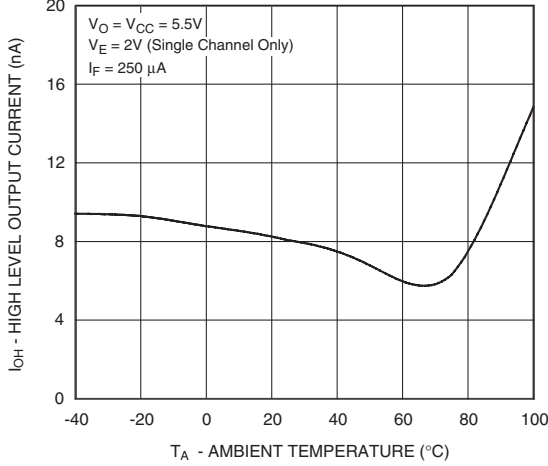

Fig. 15 Low Level Output Current vs. Ambient Temperature

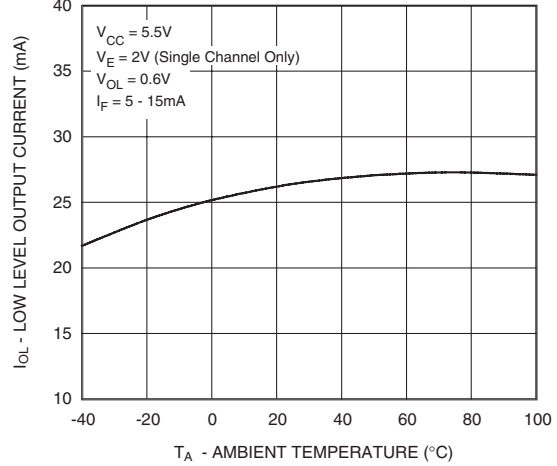

Fig. 16 Low Level Output Voltage vs. Ambient Temperature

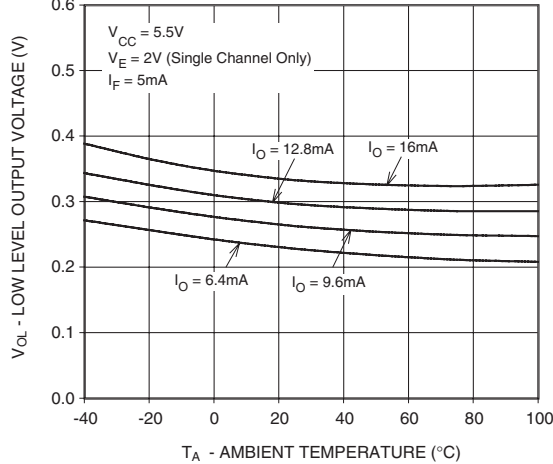
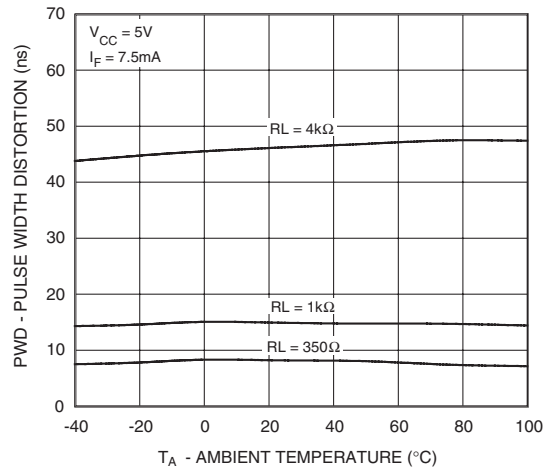

Fig. 17 Pulse Width Distortion vs. Ambient Temperature



Typical Performance Curves (HCPL0630, HCPL0631 and HCPL0661 only)

Fig. 18 Propagation Delay vs. Ambient Temperature

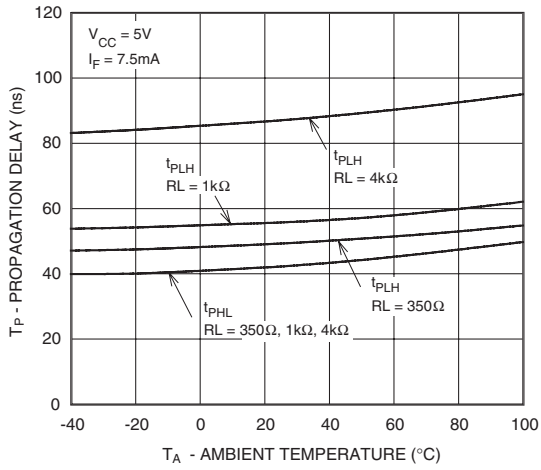
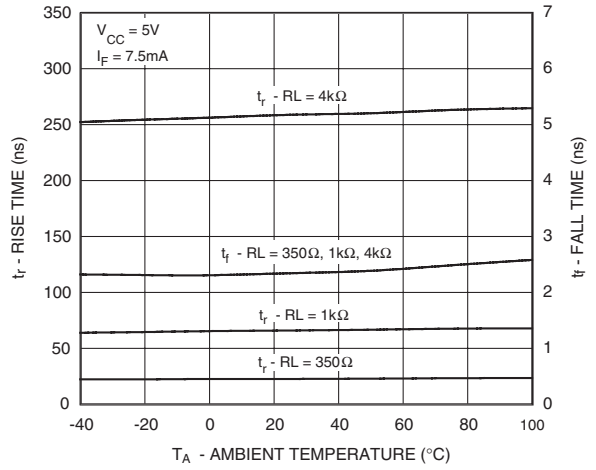

Fig. 19 Rise and Fall Times vs. Ambient Temperature



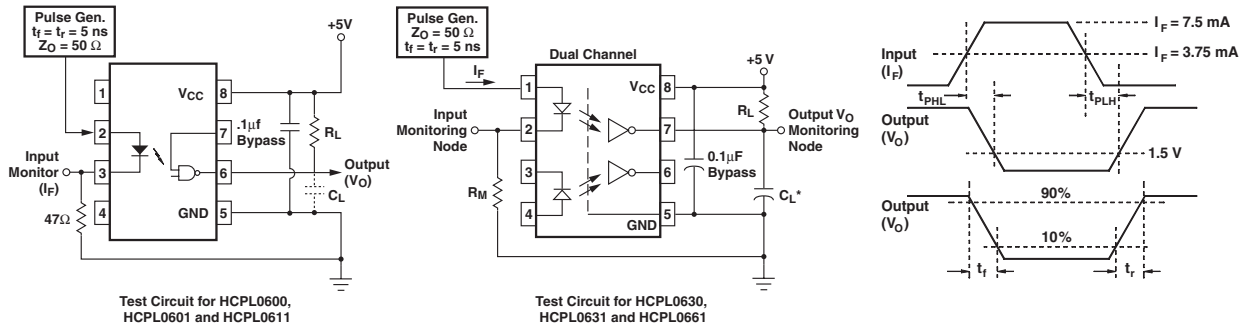

Fig. 20 Test Circuit and Waveforms for t_{PLH} , t_{PHL} , t_r and t_f .

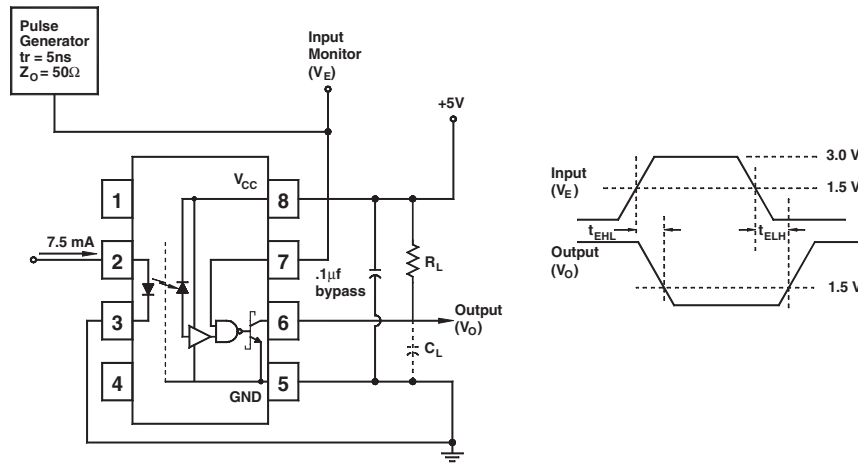
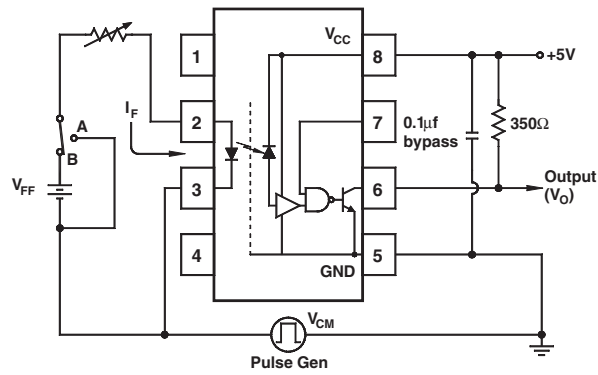

Fig. 21 Test Circuit t_{EHL} and t_{ELH} .



Test Circuit for HCPL0600, HCPL0601, and HCPL0611

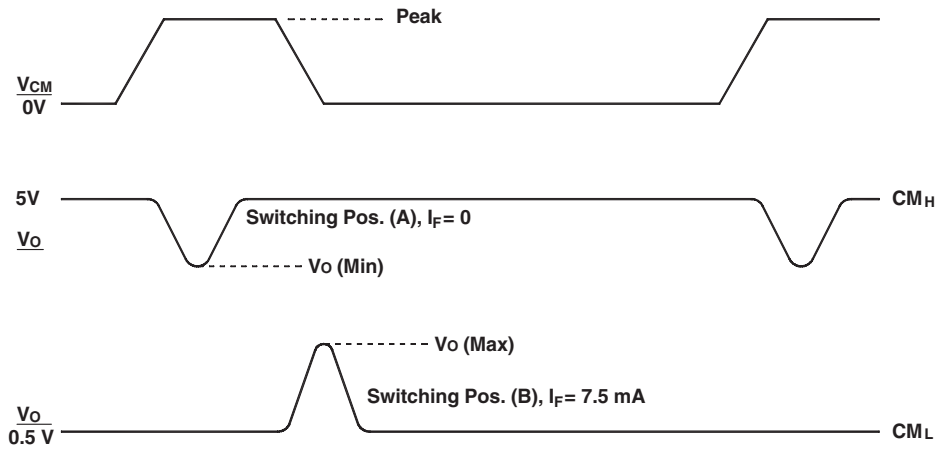
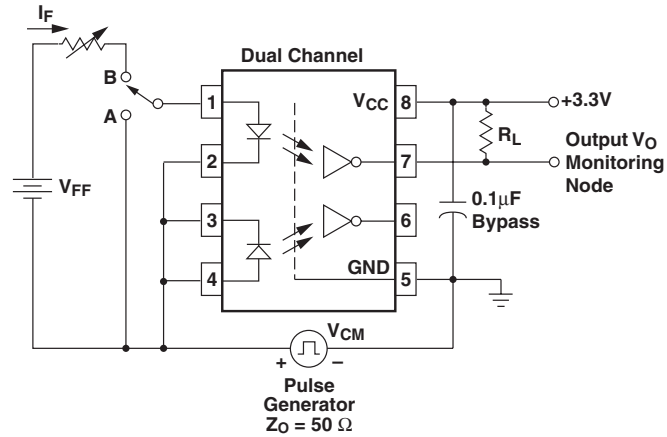

Fig. 22 Test Circuit Common Mode Transient Immunity (HCPL0600, HCPL0601 and HCPL0611)



Test Circuit for HCPL0630, HCPL0631 and HCPL0661

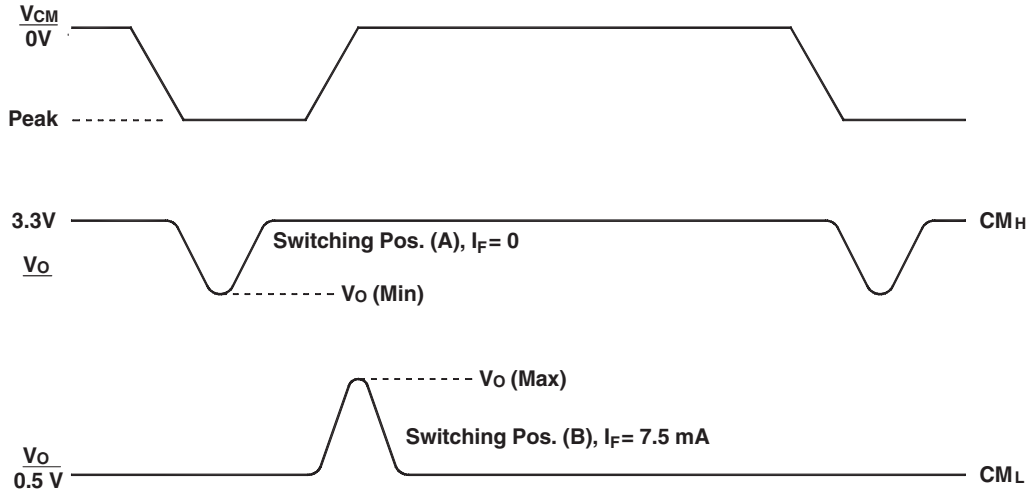
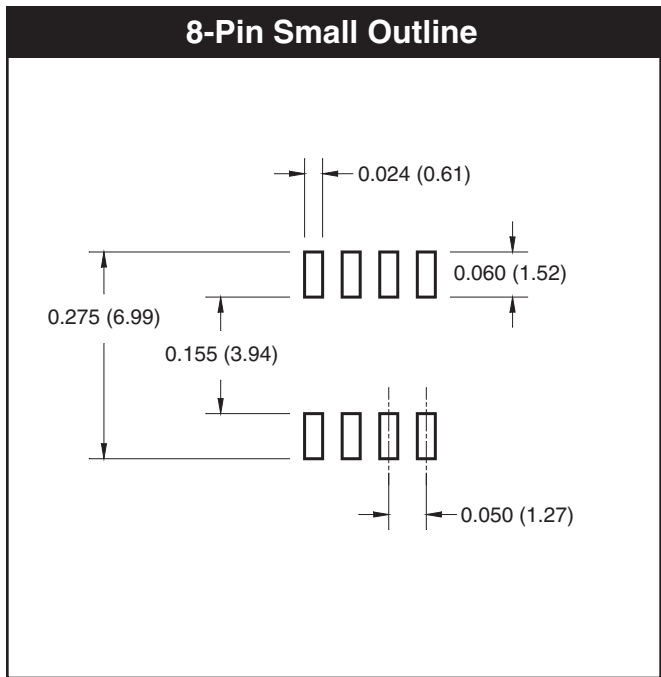

Fig. 23 Test Circuit Common Mode Transient Immunity (HCPL0630, HCPL0631 and HCPL0661)



Ordering Information

Option	Order Entry Identifier	Description
No Suffix	HCPL0600	Shipped in tubes (50 units per tube)
V	HCPL0600V	VDE0884 (pending approval)
R1	HCPL0600R1	Tape and Reel (500 units per reel)
R1V	HCPL0600R1V	VDE0884 (pending approval), Tape and Reel (500 units per reel)
R2	HCPL0600R2	Tape and Reel (2500 units per reel)
R2V	HCPL0600R2V	VDE0884 (pending approval), Tape and Reel (2500 units per reel)

Marking Information

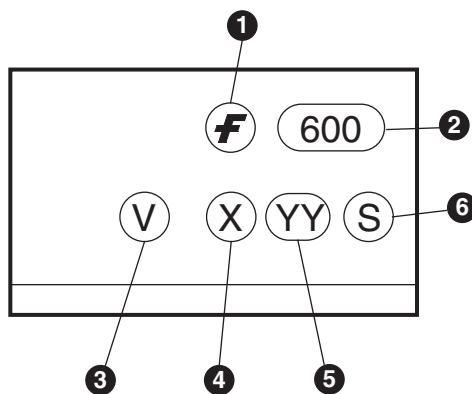

Definitions	
1	Fairchild logo
2	Device number
3	VDE mark (Note: Only appears on parts ordered with VDE option – See order entry table)
4	One digit year code, e.g., '3'
5	Two digit work week ranging from '01' to '53'
6	Assembly package code

Carrier Tape Specifications

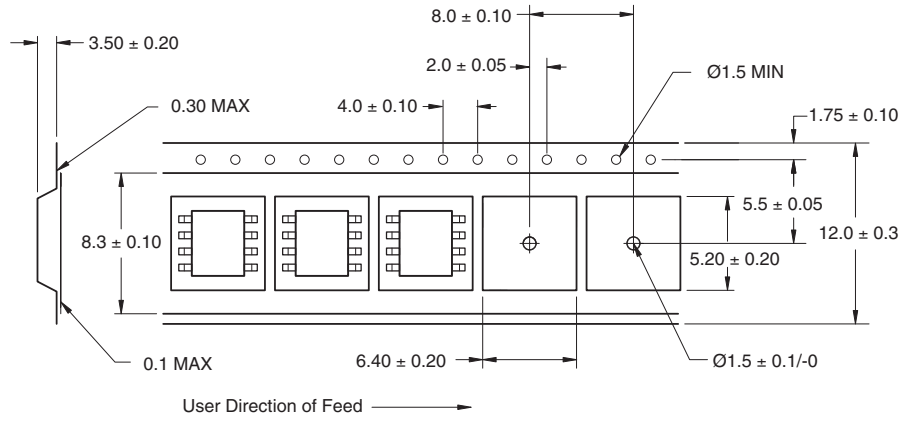

Reflow Profile

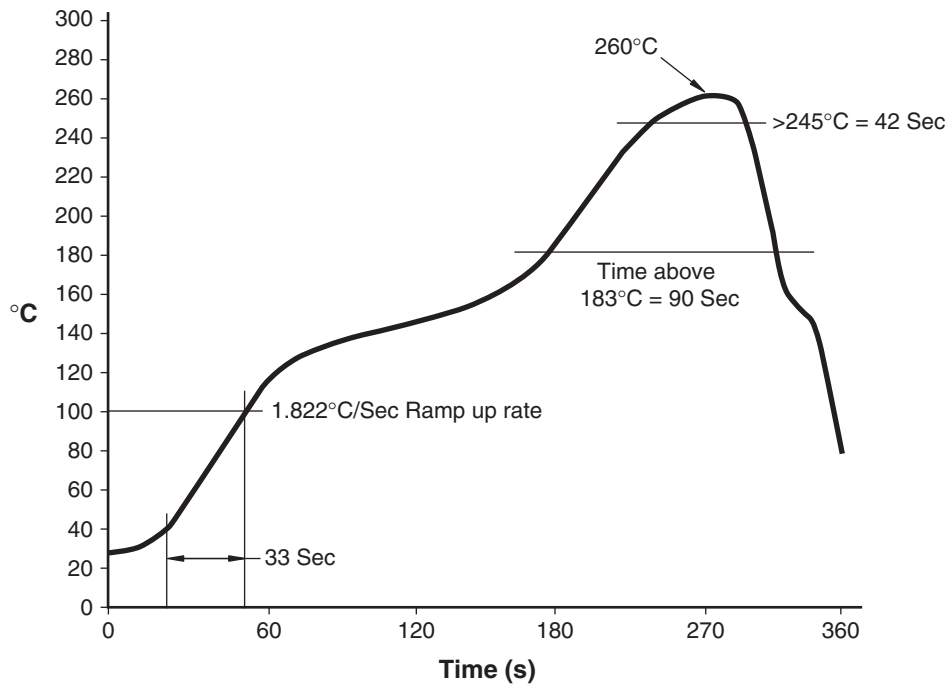

TRADEMARKS

The following are registered and unregistered trademarks Fairchild Semiconductor owns or is authorized to use and is not intended to be an exhaustive list of all such trademarks.

ACEx™	FAST®	ISOPLANAR™	PowerEdge™	SuperFET™
ActiveArray™	FASTr™	LittleFET™	PowerSaver™	SuperSOT™-3
Bottomless™	FPS™	MICROCOUPLER™	PowerTrench®	SuperSOT™-6
Build it Now™	FRFET™	MicroFET™	QFET®	SuperSOT™-8
CoolFET™	GlobalOptoisolator™	MicroPak™	QS™	SyncFET™
CROSSVOLT™	GTO™	MICROWIRE™	QT Optoelectronics™	TCM™
DOME™	HiSeC™	MSX™	Quiet Series™	TinyLogic®
EcoSPARK™	I ² C™	MSXPro™	RapidConfigure™	TINYOPTO™
E ² CMOST™	i-Lo™	OCX™	RapidConnect™	TruTranslation™
EnSigna™	ImpliedDisconnect™	OCXPro™	μSerDes™	UHC™
FACT™	IntelliMAX™	OPTOLOGIC®	ScalarPump™	UniFET™
FACT Quiet Series™		OPTOPLANAR™	SILENT SWITCHER®	UltraFET®
Across the board. Around the world.™		PACMAN™	SMART START™	VCX™
The Power Franchise®		POP™	SPM™	Wire™
Programmable Active Droop™		Power247™	Stealth™	

DISCLAIMER

FAIRCHILD SEMICONDUCTOR RESERVES THE RIGHT TO MAKE CHANGES WITHOUT FURTHER NOTICE TO ANY PRODUCTS HEREIN TO IMPROVE RELIABILITY, FUNCTION OR DESIGN. FAIRCHILD DOES NOT ASSUME ANY LIABILITY ARISING OUT OF THE APPLICATION OR USE OF ANY PRODUCT OR CIRCUIT DESCRIBED HEREIN; NEITHER DOES IT CONVEY ANY LICENSE UNDER ITS PATENT RIGHTS, NOR THE RIGHTS OF OTHERS. THESE SPECIFICATIONS DO NOT EXPAND THE TERMS OF FAIRCHILD'S WORLDWIDE TERMS AND CONDITIONS, SPECIFICALLY THE WARRANTY THEREIN, WHICH COVERS THESE PRODUCTS.

LIFE SUPPORT POLICY

FAIRCHILD'S PRODUCTS ARE NOT AUTHORIZED FOR USE AS CRITICAL COMPONENTS IN LIFE SUPPORT DEVICES OR SYSTEMS WITHOUT THE EXPRESS WRITTEN APPROVAL OF FAIRCHILD SEMICONDUCTOR CORPORATION.

As used herein:

- Life support devices or systems are devices or systems which, (a) are intended for surgical implant into the body, or (b) support or sustain life, or (c) whose failure to perform when properly used in accordance with instructions for use provided in the labeling, can be reasonably expected to result in significant injury to the user.
- A critical component is any component of a life support device or system whose failure to perform can be reasonably expected to cause the failure of the life support device or system, or to affect its safety or effectiveness.

PRODUCT STATUS DEFINITIONS

Definition of Terms

Datasheet Identification	Product Status	Definition
Advance Information	Formative or In Design	This datasheet contains the design specifications for product development. Specifications may change in any manner without notice.
Preliminary	First Production	This datasheet contains preliminary data, and supplementary data will be published at a later date. Fairchild Semiconductor reserves the right to make changes at any time without notice in order to improve design.
No Identification Needed	Full Production	This datasheet contains final specifications. Fairchild Semiconductor reserves the right to make changes at any time without notice in order to improve design.
Obsolete	Not In Production	This datasheet contains specifications on a product that has been discontinued by Fairchild semiconductor. The datasheet is printed for reference information only.

Rev. I19

Looking for pricing, stock, or lifecycle information?

Click below to explore more details on WIN SOURCE:

- ⊖ [View HCPL0661 on WIN SOURCE](#)
- ⊖ [Fairchild/ON Semiconductor Information](#)

Optimize Your Supply Chain with WIN SOURCE Solutions

- ✓ Global Sourcing Solution
- ✓ Obsolete Management
- ✓ Cost Control Management
- ✓ Shortage Management
- ✓ Alternative Solution
- ✓ Excess Inventory Management