



**THE DATASHEET OF
G3VM-401E(TR)**



G3VM-□A□/□D□/□B□/□E□

MOS FET Relays DIP, General-purpose Type

General-purpose MOS FET Relays in DIP packages for a wide range of applications

- Package: DIP 4-pin or DIP 6-pin
- Contact form: 1a (SPST-NO) or 1b (SPST-NC)
- Load voltage: 60 V, 350 V, or 400 V

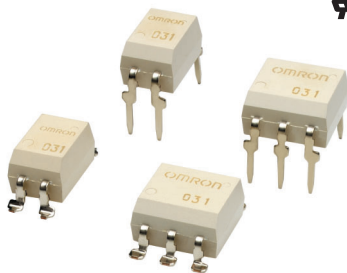

Note: The actual product is marked differently from the image shown here.

RoHS Compliant

Application Examples

- Communication equipment
- Security equipment
- Power circuit
- Test & Measurement equipment
- Industrial equipment

Package

(Unit : mm, Average)

DIP 4-pin

DIP 6-pin

PCB Terminals

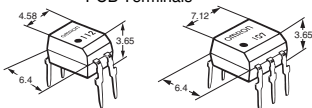

Surface-mounting Terminals

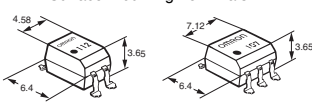

Note: The actual product is marked differently from the image shown here.

Model Number Legend

G3VM-□□□□
1 2 3 4

1. Load Voltage

- 6 : 60 V
- 35 : 350 V
- 40 : 400 V

2. Contact form

- 1 : 1a (SPST-NO)
- 3 : 1b (SPST-NC)

3. Package

- A : DIP 4-pin with PCB terminals
- B : DIP 6-pin with PCB terminals
- D : DIP 4-pin with surface-mounting terminals
- E : DIP 6-pin with surface-mounting terminals

4. Other informations

When specifications overlap, serial code is added recorded order.

Ordering Information

Package	Contact form	Load voltage (peak value) *	Continuous load current (peak value) *	Stick packaging		Minimum package quantity	Tape packaging	
				Model			Surface-mounting Terminals	Minimum package quantity
				PCB Terminals	Surface-mounting Terminals			
DIP4	1a (SPST-NO)	60 V	500 mA	G3VM-61A1	G3VM-61D1	100 pcs.	G3VM-61D1(TR)	1,500 pcs.
			120 mA	G3VM-351A	G3VM-351D		G3VM-351D(TR)	
	1b (SPST-NC)	350 V	150 mA	G3VM-353A	G3VM-353D		G3VM-353D(TR)	
			400 V	G3VM-401A	G3VM-401D		G3VM-401D(TR)	

Package	Contact form	Load voltage (peak value) *	Continuous load current (peak value) *			Stick packaging		Minimum package quantity	Tape packaging	
			Connection A, B	Connection C	Model		Surface-mounting Terminals		Minimum package quantity	
					PCB Terminals	Surface-mounting Terminals				
DIP6	1a (SPST-NO)	60 V	500 mA	1000 mA	G3VM-61B1	G3VM-61E1	50 pcs.	G3VM-61E1(TR)	1,500 pcs.	
			120 mA	240 mA	G3VM-351B	G3VM-351E		G3VM-351E(TR)		
	1b (SPST-NC)	350 V	150 mA	300 mA	G3VM-353B	G3VM-353E		G3VM-353E(TR)		
			400 V	120 mA	240 mA	G3VM-401B		G3VM-401E		G3VM-401E(TR)

* The AC peak and DC value are given for the load voltage and continuous load current.

Note: To order tape packaging for Relays with surface-mounting terminals, add "(TR)" to the end of the model number.

■ Absolute Maximum Ratings (Ta = 25°C)

Item		Symbol	G3VM-61A1 G3VM-61D1	G3VM-61B1 G3VM-61E1	G3VM-351A G3VM-351D	G3VM-351B G3VM-351E	G3VM-353A G3VM-353D	G3VM-353B G3VM-353E	G3VM-401A G3VM-401D	G3VM-401B G3VM-401E	Unit	Measurement conditions
Input	LED forward current	IF	50								mA	
	Repetitive peak LED forward current	IFP	1								A	100 μs pulses, 100 pps
	LED forward current reduction rate	ΔIF/°C	-0.5								mA/°C	Ta ≥ 25°C
	LED reverse voltage	VR	5								V	
	Connection temperature	TJ	125								°C	
Load voltage (AC peak/DC)		VOff	60		350			400		V		
Output	Continuous load current (AC peak/DC)	Connection A	500		120		150		120		mA	Connection A: AC peak/DC Connection B and C: DC
		Connection B	500		120		150		120			
		Connection C	1000		240		300		240			
	ON current reduction rate	Connection A	-5		-1.2		-1.5		-1.2		mA/°C	Ta ≥ 25°C
		Connection B	-5		-1.2		-1.5		-1.2			
Pulse ON current	Connection C	-10		-2.4		-3		-2.4		A	t=100 ms, Duty=1/10	
	Connection temperature	TJ	1.5		0.36		0.45		0.36			°C
Dielectric strength between I/O (See note 1.)		VI-o	2,500				2,500		2,500		Vrms	AC for 1 min
Ambient operating temperature		Ta	-40 to +85								°C	With no icing or condensation
Ambient storage temperature		Tstg	-55 to +125								°C	
Soldering temperature		-	260								°C	10 s

Note: 1. The dielectric strength between the input and output was checked by applying voltage between all pins as a group on the LED side and all pins as a group on the light-receiving side.

Connection Diagram (DIP 6-pin Relays)

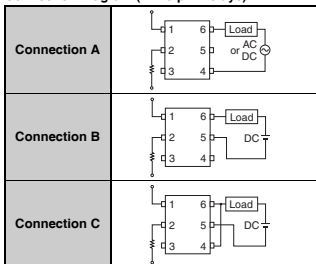

Electrical Characteristics (Ta = 25°C)

Item	Symbol	G3VM-61A1		G3VM-61B1		G3VM-351A		G3VM-351B		G3VM-353A		G3VM-353B		G3VM-401A		G3VM-401B		Unit	Measurement conditions
		G3VM-61D1	G3VM-61E1	G3VM-351D	G3VM-351E	G3VM-353D	G3VM-353E	G3VM-401D	G3VM-401E										
LED forward voltage	V _F	Minimum		1.0														V	I _F =10 mA
		Typical		1.15															
		Maximum		1.3															
Reverse current	I _R	Maximum		10														μA	V _R =5 V
		Typical																	
Capacitance between terminals	C _T	Typical		30														pF	V=0, f=1 MHz
		Maximum																	
Trigger LED forward current	I _{FT} (I _{FC}) (See note 3.)	Typical		1.6				1										mA	G3VM-353A/353D/353B/353E : I _{OFF} =10 μA Others : I _o =Continuous load current ratings
		Maximum				3													
Release LED forward current	I _{FC} (I _{FT}) (See note 3.)	Minimum		0.1														mA	G3VM-353A/353D/353B/353E : I _o =150 mA Others : I _{OFF} =100 μA
		Typical																	
Maximum resistance with output ON	R _{ON}	Typical	Connection A		1		35 (25)		15		18		17		Ω		G3VM-61A1/61D1/61B1/61E1/351A/351D/351B/351E/401A/401D/401B/401E : I _F =5 mA, I _o =Continuous load current ratings Values in parentheses are for t < 1 s. G3VM-353A/353D/353B/353E : I _o =Continuous load current ratings		
			Connection B		0.5		28		8		11								
			Connection C		0.25		14		4		6								
		Maximum	Connection A		2		50 (35)		25		35								
			Connection B		1		40		14		20								
			Connection C		-		20		7		10								
Current leakage when the relay is open	I _{LEAK}	Maximum		1														μA	G3VM-61A1/61D1/61B1/61E1/351A/351D/351B/351E/401A/401D/401B/401E : I _F =5 mA, V _{OFF} =Load voltage ratings Others : V _{OFF} =Load voltage ratings
		Typical																	
Capacitance between terminals	C _{OFF}	Typical		130		30		85		40								pF	V=0, f=1 MHz
Capacitance between I/O terminals	C _{I-O}	Typical		0.8														pF	f=1 MHz, V _S =0 V
Insulation resistance between I/O terminals	R _{I-O}	Minimum		1000														MΩ	V _{I-O} =500 VDC, RoH±50%
		Typical		10 ⁸															
Turn-ON time	t _{ON}	Typical		0.8		0.3		0.1		-		0.3						ms	I _F =5 mA, R _L =200 Ω, V _{DD} =10 V (See note 2.)
		Maximum		2				1											
Turn-OFF time	t _{OFF}	Typical		0.1				1		-		0.1							
		Maximum		0.5		1		3		1									

Note: 2. Turn-ON and Turn-OFF Times

Note: 3. These values are for Relays with NC contacts

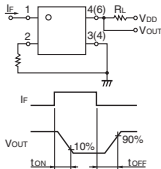

Recommended Operating Conditions

For usage with high reliability, Recommended Operation Conditions is a measure that takes into account the derating of Absolute Maximum Ratings and Electrical Characteristics.

Each item on this list is an independent condition, so it is not simultaneously satisfy several conditions.

Item	Symbol	G3VM-61A1		G3VM-61B1		G3VM-351A		G3VM-351B		G3VM-353A		G3VM-353B		G3VM-401A		G3VM-401B		Unit
		G3VM-61D1	G3VM-61E1	G3VM-351D	G3VM-351E	G3VM-353D	G3VM-353E	G3VM-401D	G3VM-401E									
Load voltage (AC peak/DC)	V _{DD}	Maximum		48				280						320				V
Operating LED forward current	I _F	Minimum						5										
		Typical		7.5		10		25		7.5								
		Maximum																
Continuous load current (AC peak/DC)	I _o	Maximum		500		100		150		100		120						
Ambient operating temperature	T _a	Minimum						-20										°C
		Maximum						65										

Introduction
General purpose
High-level-voltage
Multi-contact part
High-current and
Small and High-
High-dielectric-
Current-limiting
Low-on-state-resistance
Small and High-
Certified Models with
SOP
SSOP
USOP
VSON
G3VM-□A□/□D□/□B□/□E□

■Spacing and Insulation

Item	Minimum	Unit
Creepage distances	7.0	mm
Clearance distances	7.0	
Internal isolation thickness	0.4	

■Engineering Data

●LED forward current vs. Ambient temperature

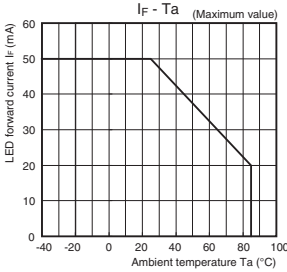

●LED forward current vs. LED forward voltage

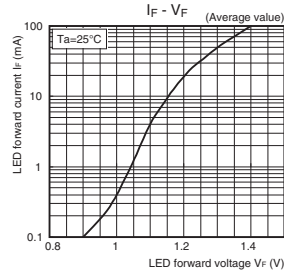

●On-state resistance vs. Ambient temperature

G3VM-61A1/61D1/61B1/61E1

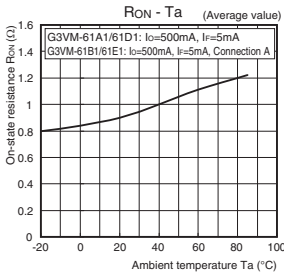

●Continuous load current vs. Ambient temperature

G3VM-61A1/61D1/61B1/61E1

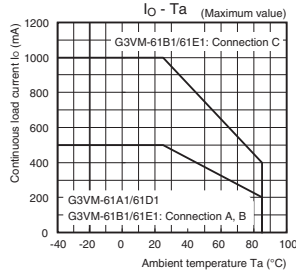

●Continuous load current vs. On-state voltage

G3VM-61A1/61D1/61B1/61E1

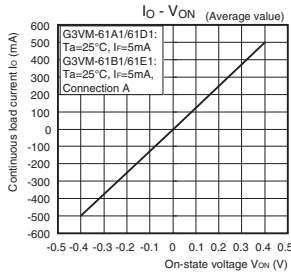

G3VM-351A/351D/351B/351E
G3VM-353A/353D/353B/353E
G3VM-401A/401D/401B/401E

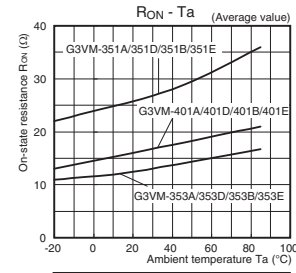

G3VM-351A/351D/401A/401D:
Io=120mA, If=5mA, t<1s
G3VM-351B/351E/401B/401E:
Io=120mA, If=5mA, t<1s, Connection A
G3VM-353A/353D: Io=150mA, t<1s
G3VM-353B/353E: Io=150mA, t<1s, Connection A

G3VM-351A/351D/351B/351E
G3VM-353A/353D/353B/353E
G3VM-401A/401D/401B/401E

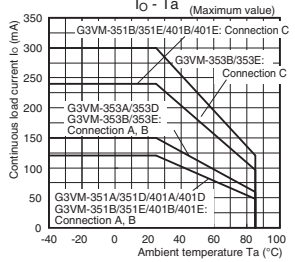

G3VM-351A/351D/351B/351E
G3VM-353A/353D/353B/353E
G3VM-401A/401D/401B/401E

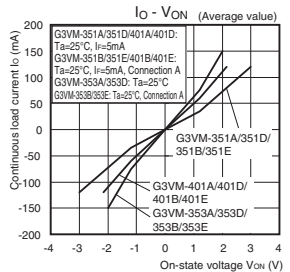

●Trigger LED forward current vs. Ambient temperature

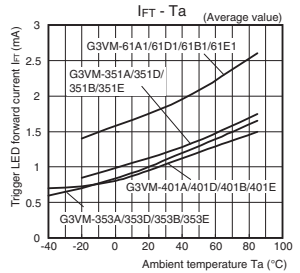

G3VM-61A1/61D1/351A/351D/401A/401D:
Io=Continuous Load Current Ratings, t<1s
G3VM-61B1/61E1/351B/351E/401B/401E:
Io=Continuous Load Current Ratings, t<1s, Connection A
G3VM-353A/353D: Ioff=10μA
G3VM-353B/353E: Ioff=10μA, Connection A

Engineering Data

● Turn ON, Turn OFF time vs. LED forward current

G3VM-61A1/61D1/61B1/61E1

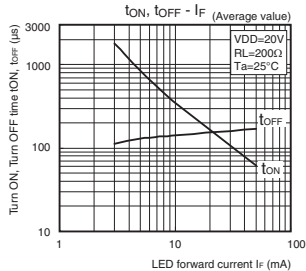

● Turn ON, Turn OFF time vs. Ambient temperature

G3VM-61A1/61D1/61B1/61E1

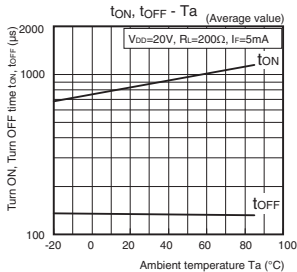

G3VM-351A/351D/351B/351E G3VM-353A/353D/353B/353E G3VM-401A/401D/401B/401E

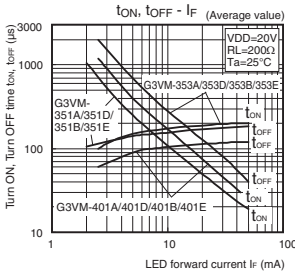

G3VM-351A/351D/351B/351E G3VM-353A/353D/353B/353E G3VM-401A/401D/401B/401E

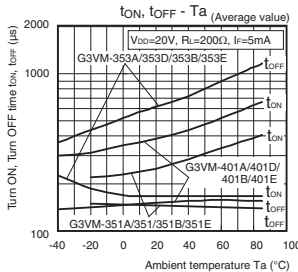

● Current leakage vs. Ambient temperature

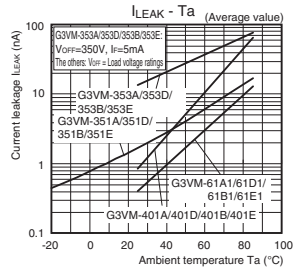

Appearance / Terminal Arrangement / Internal Connections

● Appearance

DIP (Dual Inline Package)

DIP 4-pin

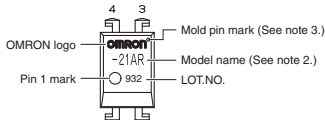

DIP 6-pin

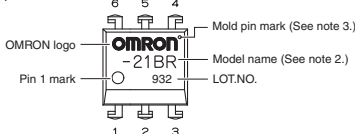

● Terminal Arrangement/Internal Connections

(Top View)

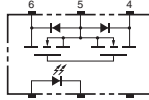
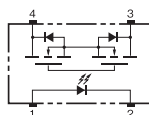

Note: 1. The actual product is marked differently from the image shown here.

Note: 2. "G3VM" does not appear in the model number on the Relay.

Note: 3. The indentation in the corner diagonally opposite from the pin 1 mark is from a pin on the mold.

Introduction
General purpose
High-side-voltage
Multi-contact pair
High-current and inductive-strength
Small and high-high-dielectric-strength
High-dielectric-strength
Current-limiting
Low-ohmic-resistance and low-resistance
Small and High-side-voltage
Certified Models with Safer Derivation
DIP
SOP
SSOP
USOP
VSON

■Dimensions (Unit: mm)

DIP4

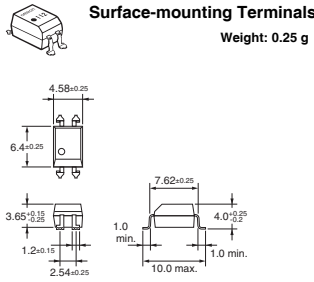
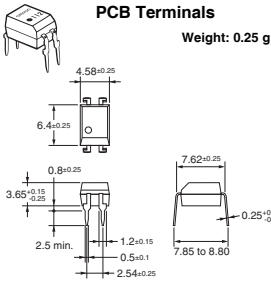

PCB Dimensions (BOTTOM VIEW)

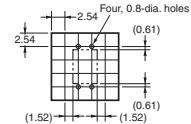

Actual Mounting Pad Dimensions (Recommended Value, Top View)

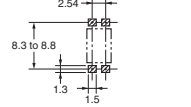

Note: The actual product is marked differently from the image shown here.

DIP6

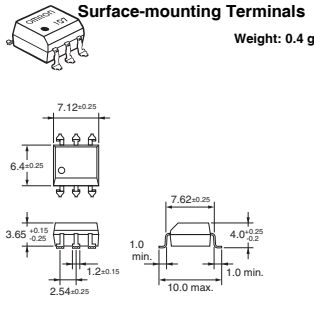
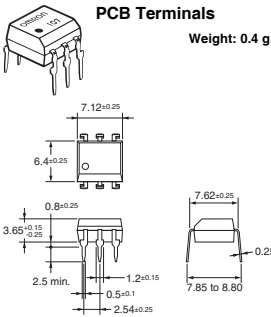

PCB Dimensions (BOTTOM VIEW)

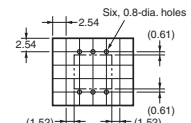

Actual Mounting Pad Dimensions (Recommended Value, Top View)

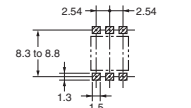

Note: The actual product is marked differently from the image shown here.

■Approved Standards

UL recognized

Model				Approved Standards	Contact form	File No.
G3VM-61A1	G3VM-61D1	G3VM-61B1	G3VM-61E1	UL (recognized)	1a (SPST-NO)	E80555
G3VM-351A	G3VM-351D	G3VM-351B	G3VM-351E			
G3VM-401A	G3VM-401D	G3VM-401B	G3VM-401E			
G3VM-353A	G3VM-353D	G3VM-353B	G3VM-353E		1b (SPST-NC)	

Models Certified by BSI for EN/IEC Standards



Model	Approved Standards	Contact form	File No.
G3VM-351A	EN 60950/EN 60065 (BSI certified)	1a (SPST-NO)	8816
G3VM-351D			8817

■Safety Precautions





- Refer to the *Common Precautions for All MOS FET Relays* for precautions that apply to all MOS FET Relays.

Looking for pricing, stock, or lifecycle information?

Click below to explore more details on WIN SOURCE:

-  [View G3VM-401E\(TR\) on WIN SOURCE](#)
-  [Omron Information](#)

Optimize Your Supply Chain with WIN SOURCE Solutions

-  Global Sourcing Solution
-  Obsolete Management
-  Cost Control Management
-  Shortage Management
-  Alternative Solution
-  Excess Inventory Management