



Is Now Part of



**ON Semiconductor®**

To learn more about ON Semiconductor, please visit our website at  
[www.onsemi.com](http://www.onsemi.com)

Please note: As part of the Fairchild Semiconductor integration, some of the Fairchild orderable part numbers will need to change in order to meet ON Semiconductor's system requirements. Since the ON Semiconductor product management systems do not have the ability to manage part nomenclature that utilizes an underscore (\_), the underscore (\_) in the Fairchild part numbers will be changed to a dash (-). This document may contain device numbers with an underscore (\_). Please check the ON Semiconductor website to verify the updated device numbers. The most current and up-to-date ordering information can be found at [www.onsemi.com](http://www.onsemi.com). Please email any questions regarding the system integration to [Fairchild\\_questions@onsemi.com](mailto:Fairchild_questions@onsemi.com).

ON Semiconductor and the ON Semiconductor logo are trademarks of Semiconductor Components Industries, LLC dba ON Semiconductor or its subsidiaries in the United States and/or other countries. ON Semiconductor owns the rights to a number of patents, trademarks, copyrights, trade secrets, and other intellectual property. A listing of ON Semiconductor's product/patent coverage may be accessed at [www.onsemi.com/site/pdf/Patent-Marking.pdf](http://www.onsemi.com/site/pdf/Patent-Marking.pdf). ON Semiconductor reserves the right to make changes without further notice to any products herein. ON Semiconductor makes no warranty, representation or guarantee regarding the suitability of its products for any particular purpose, nor does ON Semiconductor assume any liability arising out of the application or use of any product or circuit, and specifically disclaims any and all liability, including without limitation special, consequential or incidental damages. Buyer is responsible for its products and applications using ON Semiconductor products, including compliance with all laws, regulations and safety requirements or standards, regardless of any support or applications information provided by ON Semiconductor. "Typical" parameters which may be provided in ON Semiconductor data sheets and/or specifications can and do vary in different applications and actual performance may vary over time. All operating parameters, including "Typicals" must be validated for each customer application by customer's technical experts. ON Semiconductor does not convey any license under its patent rights nor the rights of others. ON Semiconductor products are not designed, intended, or authorized for use as a critical component in life support systems or any FDA Class 3 medical devices or medical devices with a same or similar classification in a foreign jurisdiction or any devices intended for implantation in the human body. Should Buyer purchase or use ON Semiconductor products for any such unintended or unauthorized application, Buyer shall indemnify and hold ON Semiconductor and its officers, employees, subsidiaries, affiliates, and distributors harmless against all claims, costs, damages, and expenses, and reasonable attorney fees arising out of, directly or indirectly, any claim of personal injury or death associated with such unintended or unauthorized use, even if such claim alleges that ON Semiconductor was negligent regarding the design or manufacture of the part. ON Semiconductor is an Equal Opportunity/Affirmative Action Employer. This literature is subject to all applicable copyright laws and is not for resale in any manner.



# FSBB10CH120D

## Motion SPM® 3 Series

### Features

- UL Certified No. E209204 (UL1557)
- 1200 V - 10 A 3-Phase IGBT Inverter with Integral Gate Drivers and Protection
- Low-Loss, Short-Circuit Rated IGBTs
- Very Low Thermal Resistance Using Al<sub>2</sub>O<sub>3</sub> DBC Substrate
- Dedicated Vs Pins Simplify PCB Layout
- Separate Open-Emitter Pins from Low-Side IGBTs for Three-Phase Current Sensing
- Single-Grounded Power Supply
- LVIC Temperature-Sensing Built-In for Temperature Monitoring
- Isolation Rating: 2500 V<sub>rms</sub> / 1 min.

### Applications

- Motion Control - Industrial Motor (AC 400V Class)

### Related Resources

- [AN-9095 - Motion SPM® 3 Series User's Guide](#)
- [AN-9086 - SPM® 3 Package Mounting Guidance](#)

### General Description

FSBB10CH120D is an advanced Motion SPM® 3 module providing a fully-featured, high-performance inverter output stage for AC Induction, BLDC, and PMSM motors. These modules integrate optimized gate drive of the built-in IGBTs to minimize EMI and losses, while also providing multiple on-module protection features including under-voltage lockouts, over-current shutdown, thermal monitoring of drive IC, and fault reporting. The built-in, high-speed HVIC requires only a single supply voltage and translates the incoming logic-level gate inputs to the high-voltage, high-current drive signals required to properly drive the module's internal IGBTs. Separate negative IGBT terminals are available for each phase to support the widest variety of control algorithms.

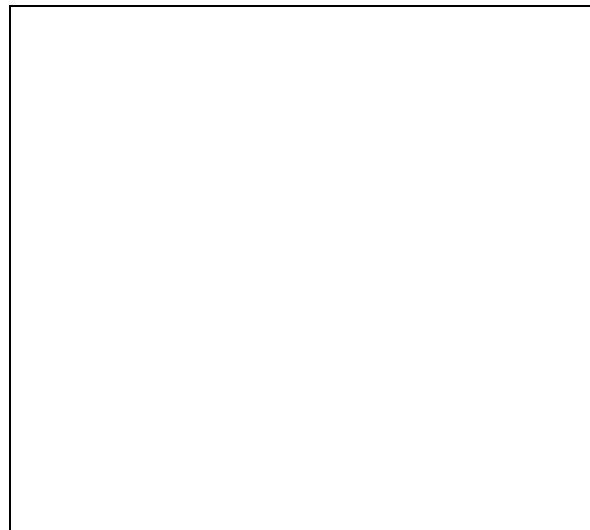

**Figure 1. 3D Package Drawing**  
(Click to Activate 3D Content)

### Package Marking and Ordering Information

Device	Device Marking	Package	Packing Type	Quantity
FSBB10CH120D	FSBB10CH120D	SPMMC-027	Rail	10

### Integrated Power Functions

- 1200 V - 10 A IGBT inverter for three-phase DC / AC power conversion (Please refer to Figure 3)

### Integrated Drive, Protection and System Control Functions

- For inverter high-side IGBTs: gate drive circuit, high-voltage isolated high-speed level shifting control circuit Under-Voltage Lock-Out Protection (UVLO)  
Note: Available bootstrap circuit example is given in Figures 5 and 15.
- For inverter low-side IGBTs: gate drive circuit, Short-Circuit Protection (SCP) control supply circuit Under-Voltage Lock-Out Protection (UVLO)
- Fault signaling: corresponding to UVLO (low-side supply) and SC faults
- Input interface: active-HIGH interface, works with 3.3 / 5 V logic, Schmitt-trigger input

### Pin Configuration

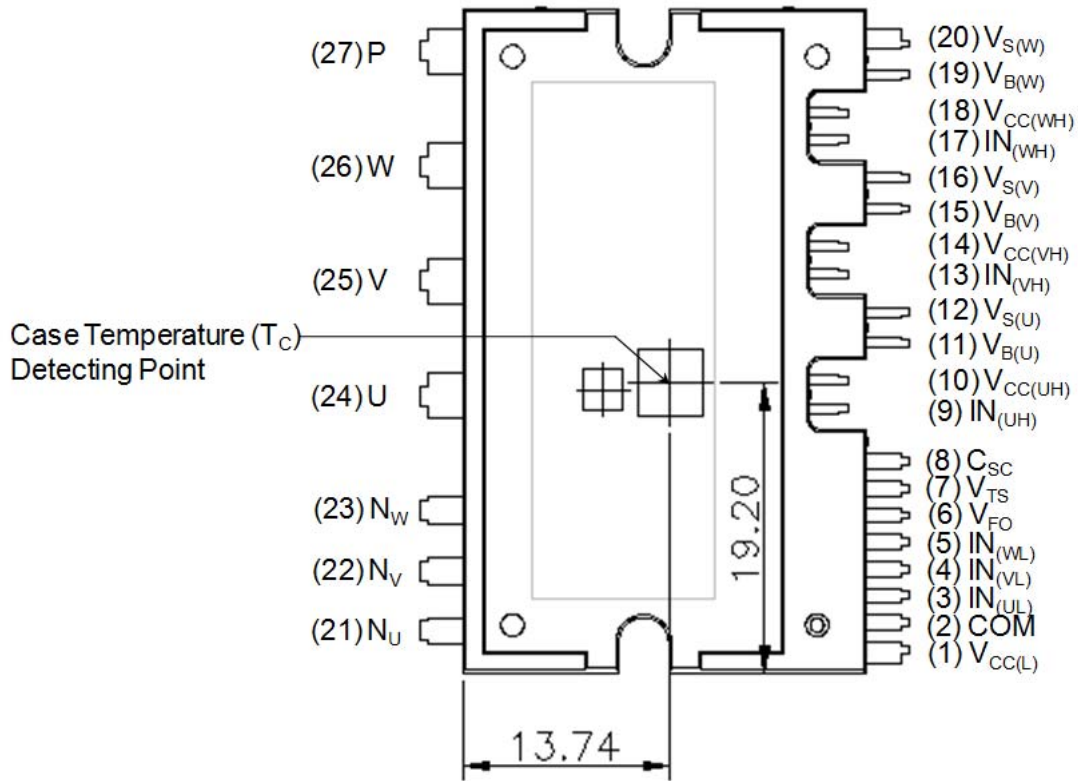
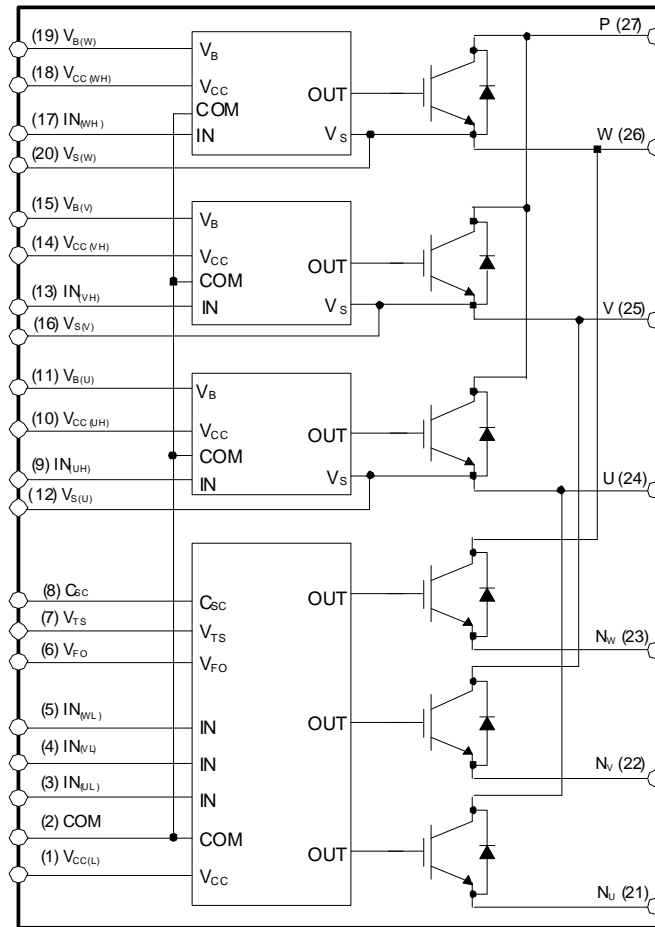

Figure 2. Top View

## Pin Descriptions

Pin Number	Pin Name	Pin Description
1	$V_{CC(L)}$	Low-Side Common Bias Voltage for IC and IGBTs Driving
2	COM	Common Supply Ground
3	$IN_{(UL)}$	Signal Input for Low-Side U Phase
4	$IN_{(VL)}$	Signal Input for Low-Side V Phase
5	$IN_{(WL)}$	Signal Input for Low-Side W Phase
6	$V_{FO}$	Fault Output
7	$V_{TS}$	Output for LVIC Temperature Sensing Voltage Output
8	$C_{SC}$	Capacitor (Low-Pass Filter) for Short-Circuit Current Detection Input
9	$IN_{(UH)}$	Signal Input for High-Side U Phase
10	$V_{CC(UH)}$	High-Side Bias Voltage for U Phase IC
11	$V_{B(U)}$	High-Side Bias Voltage for U Phase IGBT Driving
12	$V_{S(U)}$	High-Side Bias Voltage Ground for U Phase IGBT Driving
13	$IN_{(VH)}$	Signal Input for High-Side V Phase
14	$V_{CC(VH)}$	High-Side Bias Voltage for V Phase IC
15	$V_{B(V)}$	High-Side Bias Voltage for V Phase IGBT Driving
16	$V_{S(V)}$	High-Side Bias Voltage Ground for V Phase IGBT Driving
17	$IN_{(WH)}$	Signal Input for High-Side W Phase
18	$V_{CC(WH)}$	High-Side Bias Voltage for W Phase IC
19	$V_{B(W)}$	High-Side Bias Voltage for W Phase IGBT Driving
20	$V_{S(W)}$	High-Side Bias Voltage Ground for W Phase IGBT Driving
21	$N_U$	Negative DC-Link Input for U Phase
22	$N_V$	Negative DC-Link Input for V Phase
23	$N_W$	Negative DC-Link Input for W Phase
24	U	Output for U Phase
25	V	Output for V Phase
26	W	Output for W Phase
27	P	Positive DC-Link Input

### Internal Equivalent Circuit and Input/Output Pins



**Figure 3. Internal Block Diagram**

**Notes:**

1. Inverter low-side is composed of three IGBTs, freewheeling diodes for each IGBT, and one control IC. It has gate drive and protection functions.
2. Inverter power side is composed of four inverter DC-link input terminals and three inverter output terminals.
3. Inverter high-side is composed of three IGBTs, freewheeling diodes, and three drive ICs for each IGBT.

## Absolute Maximum Ratings ( $T_J = 25^\circ\text{C}$ , Unless Otherwise Specified)

### Inverter Part

Symbol	Parameter	Conditions	Rating	Unit
$V_{PN}$	Supply Voltage	Applied between P - $N_U$ , $N_V$ , $N_W$	900	V
$V_{PN(\text{Surge})}$	Supply Voltage (Surge)	Applied between P - $N_U$ , $N_V$ , $N_W$	1000	V
$V_{CES}$	Collector - Emitter Voltage		1200	V
$\pm I_C$	Each IGBT Collector Current	$T_C = 25^\circ\text{C}$ , $T_J \leq 150^\circ\text{C}$ (Note 4)	10	A
$\pm I_{CP}$	Each IGBT Collector Current (Peak)	$T_C = 25^\circ\text{C}$ , $T_J \leq 150^\circ\text{C}$ , Under 1 ms Pulse Width (Note 4)	20	A
$P_C$	Collector Dissipation	$T_C = 25^\circ\text{C}$ per One Chip (Note 4)	69	W
$T_J$	Operating Junction Temperature		-40 ~ 150	$^\circ\text{C}$

### Control Part

Symbol	Parameter	Conditions	Rating	Unit
$V_{CC}$	Control Supply Voltage	Applied between $V_{CC(H)}$ , $V_{CC(L)}$ - COM	20	V
$V_{BS}$	High-Side Control Bias Voltage	Applied between $V_{B(U)} - V_{S(U)}$ , $V_{B(V)} - V_{S(V)}$ , $V_{B(W)} - V_{S(W)}$	20	V
$V_{IN}$	Input Signal Voltage	Applied between $IN_{(UH)}$ , $IN_{(VH)}$ , $IN_{(WH)}$ , $IN_{(UL)}$ , $IN_{(VL)}$ , $IN_{(WL)}$ - COM	-0.3 ~ $V_{CC}+0.3$	V
$V_{FO}$	Fault Output Supply Voltage	Applied between $V_{FO}$ - COM	-0.3 ~ $V_{CC}+0.3$	V
$I_{FO}$	Fault Output Current	Sink Current at $V_{FO}$ pin	2	mA
$V_{SC}$	Current Sensing Input Voltage	Applied between $C_{SC}$ - COM	-0.3 ~ $V_{CC}+0.3$	V

### Total System

Symbol	Parameter	Conditions	Rating	Unit
$V_{PN(\text{PROT})}$	Self Protection Supply Voltage Limit (Short Circuit Protection Capability)	$V_{CC} = V_{BS} = 13.5 \sim 16.5 \text{ V}$ , $T_J = 150^\circ\text{C}$ , Non-repetitive, $< 2 \mu\text{s}$	800	V
$T_C$	Module Case Operation Temperature	See Figure 2	-40 ~ 125	$^\circ\text{C}$
$T_{STG}$	Storage Temperature		-40 ~ 125	$^\circ\text{C}$
$V_{ISO}$	Isolation Voltage	60 Hz, Sinusoidal, AC 1 minute, Connection Pins to Heat Sink Plate	2500	$V_{\text{rms}}$

### Thermal Resistance

Symbol	Parameter	Conditions	Min.	Typ.	Max.	Unit
$R_{th(j-c)Q}$	Junction to Case Thermal Resistance (Note 5)	Inverter IGBT part (per 1 / 6 module)	-	-	1.80	$^\circ\text{C} / \text{W}$
$R_{th(j-c)F}$		Inverter FWD part (per 1 / 6 module)	-	-	2.75	$^\circ\text{C} / \text{W}$

**Note:**

- These values had been made an acquisition by the calculation considered to design factor.
- For the measurement point of case temperature ( $T_C$ ), please refer to Figure 2.

### Electrical Characteristics (T<sub>J</sub> = 25°C, Unless Otherwise Specified)

#### Inverter Part

Symbol	Parameter	Conditions	Min.	Typ.	Max.	Unit
V <sub>CE(SAT)</sub>	Collector - Emitter Saturation Voltage	V <sub>CC</sub> = V <sub>BS</sub> = 15 V V <sub>IN</sub> = 5 V I <sub>C</sub> = 10 A, T <sub>J</sub> = 25°C	-	2.20	2.80	V
V <sub>F</sub>	FWDI Forward Voltage	V <sub>IN</sub> = 0 V I <sub>F</sub> = 10 A, T <sub>J</sub> = 25°C	-	2.20	2.80	V
HS	t <sub>ON</sub>	Switching Times V <sub>PN</sub> = 600 V, V <sub>CC</sub> = 15 V, I <sub>C</sub> = 10 A T <sub>J</sub> = 25°C V <sub>IN</sub> = 0 V ↔ 5 V, Inductive Load See Figure 5 (Note 6)	0.45	0.85	1.35	μs
	t <sub>C(ON)</sub>		-	0.25	0.60	μs
	t <sub>OFF</sub>		-	0.95	1.50	μs
	t <sub>C(OFF)</sub>		-	0.10	0.45	μs
	t <sub>rr</sub>		-	0.25	-	μs
LS	t <sub>ON</sub>	Switching Times V <sub>PN</sub> = 600 V, V <sub>CC</sub> = 15 V, I <sub>C</sub> = 10 A T <sub>J</sub> = 25°C V <sub>IN</sub> = 0 V ↔ 5 V, Inductive Load See Figure 5 (Note 6)	0.35	0.75	1.25	μs
	t <sub>C(ON)</sub>		-	0.20	0.55	μs
	t <sub>OFF</sub>		-	0.95	1.50	μs
	t <sub>C(OFF)</sub>		-	0.10	0.45	μs
	t <sub>rr</sub>		-	0.20	-	μs
I <sub>CES</sub>	Collector - Emitter Leakage Current	V <sub>CE</sub> = V <sub>CES</sub>	-	-	5	mA

**Note:**

6. t<sub>ON</sub> and t<sub>OFF</sub> include the propagation delay time of the internal drive IC. t<sub>C(ON)</sub> and t<sub>C(OFF)</sub> are the switching time of IGBT itself under the given gate driving condition internally. For the detailed information, please see Figure 4.

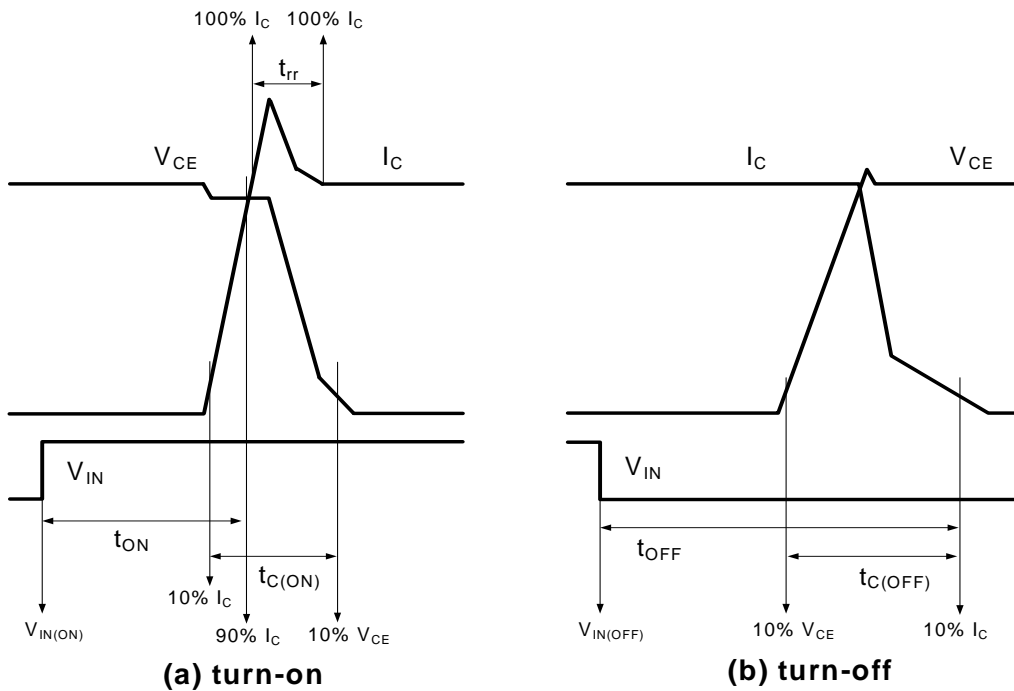

Figure 4. Switching Time Definition

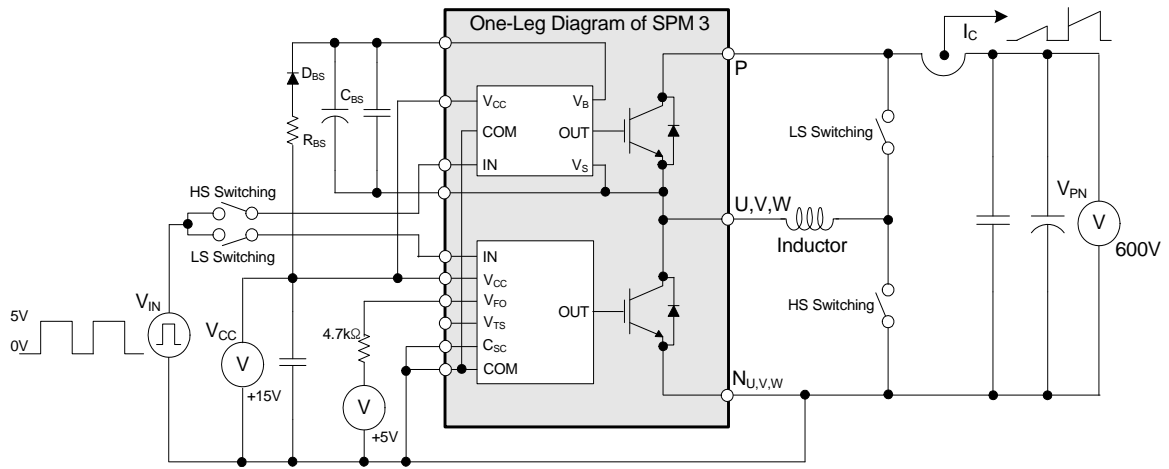

Figure 5. Example Circuit for Switching Test

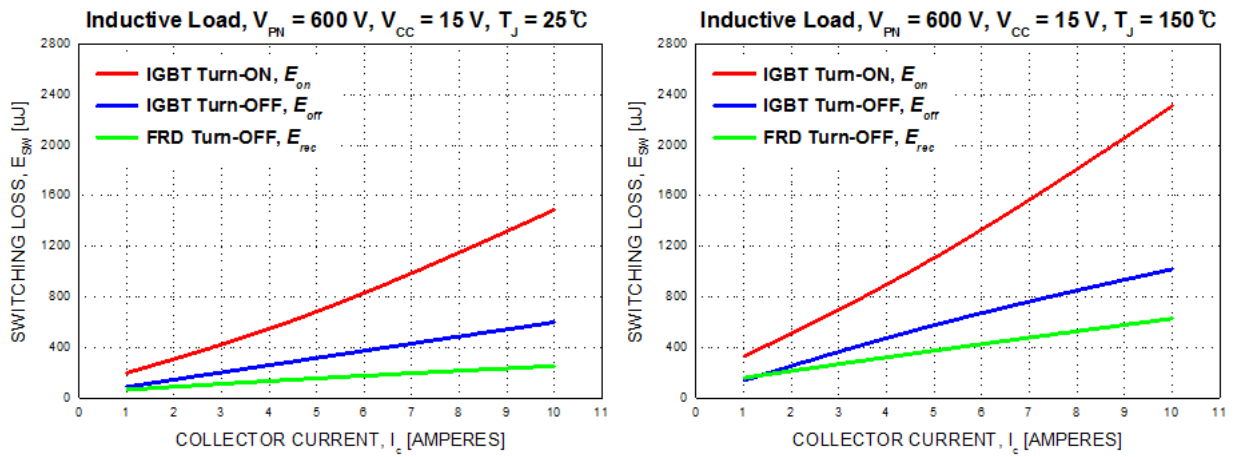

Figure 6. Switching Loss Characteristics

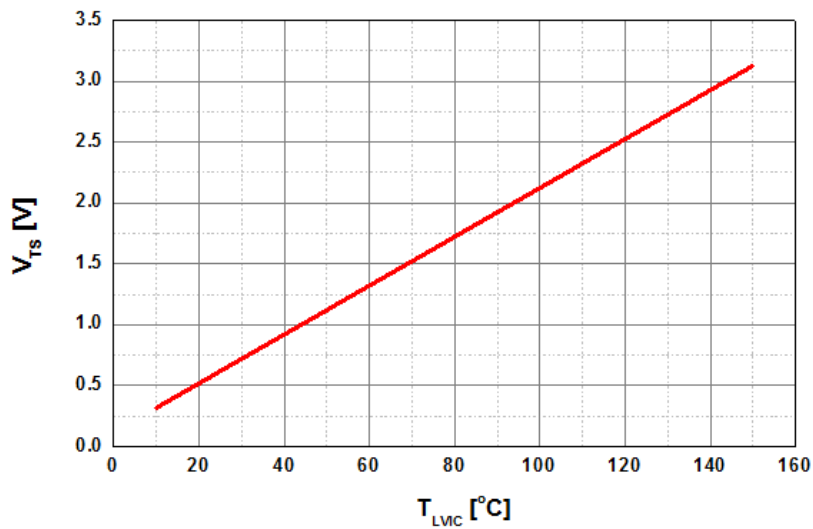

Figure 7. Temperature Profile of  $V_{TS}$  (Typical)

**Control Part**

Symbol	Parameter	Conditions	Min.	Typ.	Max.	Unit
$I_{QCCH}$	Quiescent $V_{CC}$ Supply Current	$V_{CC(UH,VH,WH)} = 15\text{ V}$ , $I_{N(UH,VH,WH)} = 0\text{ V}$	-	-	0.15	mA
$I_{QCCL}$		$V_{CC(L)} = 15\text{ V}$ , $I_{N(UL,VL,WL)} = 0\text{ V}$	-	-	5.00	mA
$I_{PCCH}$	Operating $V_{CC}$ Supply Current	$V_{CC(UH,VH,WH)} = 15\text{ V}$ , $f_{PWM} = 20\text{ kHz}$ , duty = 50%, applied to one PWM signal input for High-Side	-	-	0.30	mA
$I_{PCCL}$		$V_{CC(L)} = 15\text{ V}$ , $f_{PWM} = 20\text{ kHz}$ , duty = 50%, applied to one PWM signal input for Low-Side	-	-	8.50	mA
$I_{QBS}$	Quiescent $V_{BS}$ Supply Current	$V_{BS} = 15\text{ V}$ , $I_{N(UH, VH, WH)} = 0\text{ V}$	-	-	0.30	mA
$I_{PBS}$	Operating $V_{BS}$ Supply Current	$V_{CC} = V_{BS} = 15\text{ V}$ , $f_{PWM} = 20\text{ kHz}$ , duty = 50%, applied to one PWM signal input for High-Side	-	-	4.50	mA
$V_{FOH}$	Fault Output Voltage	$V_{CC} = 15\text{ V}$ , $V_{SC} = 0\text{ V}$ , $V_{FO}$ Circuit: 4.7 k $\Omega$ to 5 V Pull-up	4.5	-	-	V
$V_{FOL}$		$V_{CC} = 15\text{ V}$ , $V_{SC} = 1\text{ V}$ , $V_{FO}$ Circuit: 4.7 k $\Omega$ to 5 V Pull-up	-	-	0.5	V
$V_{SC(ref)}$	Short Circuit Trip Level	$V_{CC} = 15\text{ V}$ (Note 7)	0.43	0.50	0.57	V
$UV_{CCD}$	Supply Circuit Under-Voltage Protection	Detection Level	10.3	-	12.8	V
$UV_{CCR}$		Reset Level	10.8	-	13.3	V
$UV_{BSD}$		Detection Level	9.5	-	12.0	V
$UV_{BSR}$		Reset Level	10.0	-	12.5	V
$t_{FOD}$	Fault-Out Pulse Width		50	-	-	$\mu\text{s}$
$V_{TS}$	LVIC Temperature Sensing Voltage Output	$V_{CC(L)} = 15\text{ V}$ , $T_{LVIC} = 25^\circ\text{C}$ (Note 8) See Figure 7	540	640	740	mV
$V_{IN(ON)}$	ON Threshold Voltage	Applied between $I_{N(UH, VH, WH)} - \text{COM}$ , $I_{N(UL, VL, WL)} - \text{COM}$	-	-	2.6	V
$V_{IN(OFF)}$	OFF Threshold Voltage		0.8	-	-	V

**Note:**

- 7. Short-circuit current protection is functioning only at the low - sides.
- 8.  $T_{LVIC}$  is the temperature of LVIC itself.  $V_{TS}$  is only for sensing temperature of LVIC and can not shutdown IGBTs automatically.

### Recommended Operating Conditions

Symbol	Parameter	Conditions	Value			Unit
			Min.	Typ.	Max.	
V <sub>PN</sub>	Supply Voltage	Applied between P - N <sub>U</sub> , N <sub>V</sub> , N <sub>W</sub>	300	600	800	V
V <sub>CC</sub>	Control Supply Voltage	Applied between V <sub>CC(UH, VH, WH)</sub> - COM, V <sub>CC(L)</sub> - COM	13.5	15.0	16.5	V
V <sub>BS</sub>	High-Side Bias Voltage	Applied between V <sub>B(U)</sub> - V <sub>S(U)</sub> , V <sub>B(V)</sub> - V <sub>S(V)</sub> , V <sub>B(W)</sub> - V <sub>S(W)</sub>	13.0	15.0	18.5	V
dV <sub>CC</sub> /dt, dV <sub>BS</sub> /dt	Control Supply Variation		-1	-	1	V / μs
t <sub>dead</sub>	Blanking Time for Preventing Arm - Short	For Each Input Signal	2.0	-	-	μs
f <sub>PWM</sub>	PWM Input Signal	-40°C ≤ T <sub>C</sub> ≤ 125°C, -40°C ≤ T <sub>J</sub> ≤ 150°C	-	-	20	kHz
V <sub>SEN</sub>	Voltage for Current Sensing	Applied between N <sub>U</sub> , N <sub>V</sub> , N <sub>W</sub> - COM (Including Surge Voltage)	-5		5	V
PW <sub>IN(ON)</sub>	Minimum Input Pulse Width	I <sub>C</sub> ≤ 20 A, Wiring Inductance between N <sub>U</sub> , V, W and DC Link N < 10nH (Note 9)	1.5	-	-	μs
PW <sub>IN(OFF)</sub>			1.5	-	-	
T <sub>J</sub>	Junction Temperature		-40	-	150	°C

**Note:**

9. This product might not make response if input pulse width is less than the recommended value.

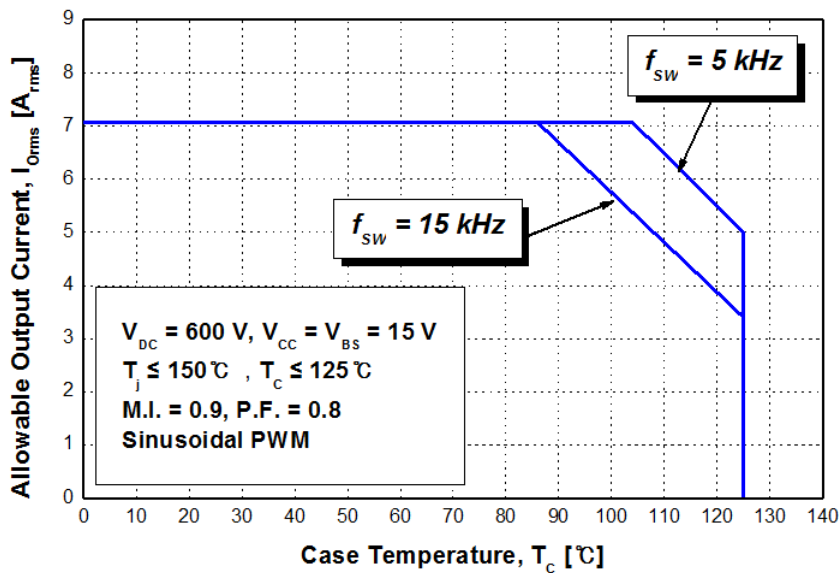

**Figure 8. Allowable Maximum Output Current**

**Note:**

10. This allowable output current value is the reference data for the safe operation of this product. This may be different from the actual application and operating condition.

### Mechanical Characteristics and Ratings

Parameter	Conditions	Limits			Unit	
		Min.	Typ.	Max.		
Device Flatness	See Figure 9	0	-	+150	μm	
Mounting Torque	Mounting Screw: M3	Recommended 0.7 N • m	0.6	0.7	0.8	N • m
	See Figure 10	Recommended 7.1 kg • cm	6.2	7.1	8.1	kg • cm
Terminal Pulling Strength	Load 19.6 N	10	-	-	s	
Terminal Bending Strength	Load 9.8 N, 90 deg. bend	2	-	-	times	
Weight		-	15	-	g	

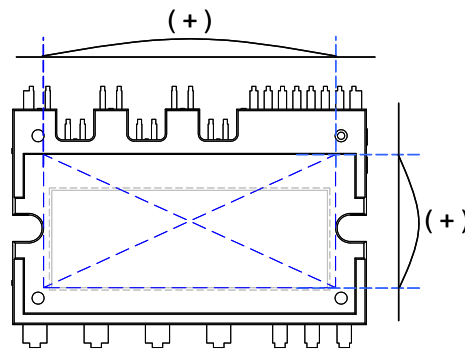

Figure 9. Flatness Measurement Position

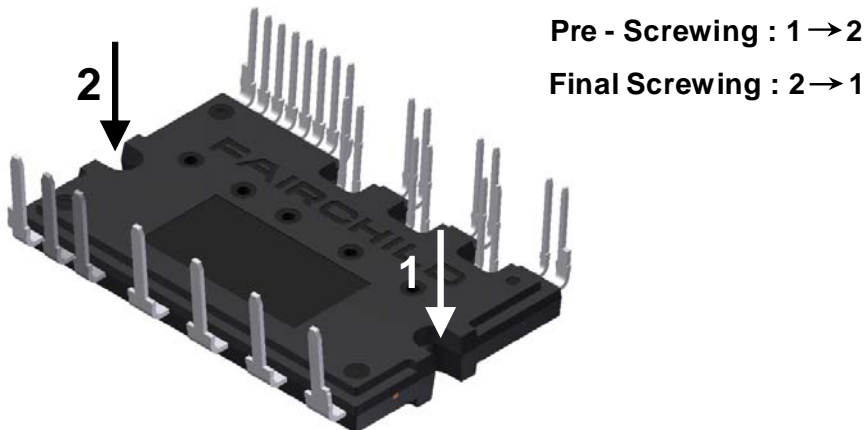
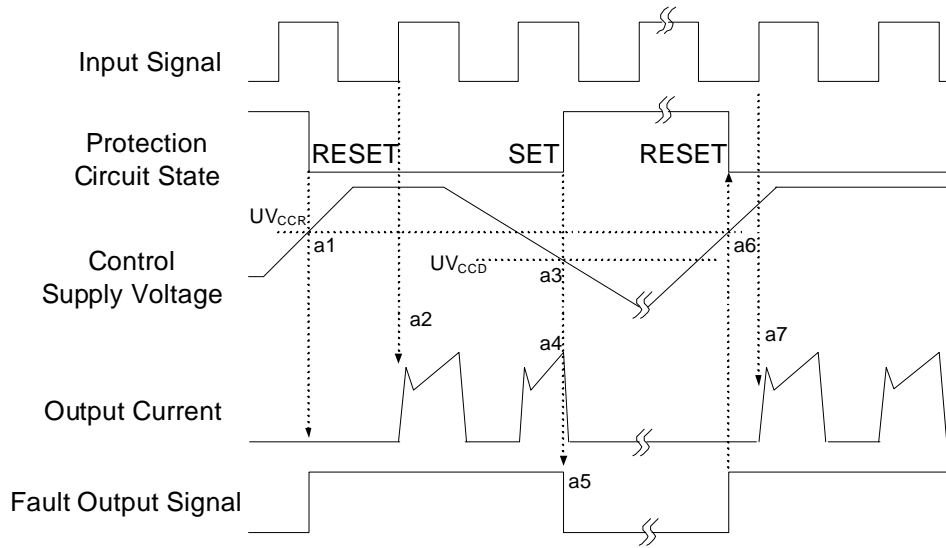

Figure 10. Mounting Screws Torque Order

**Note:**

- 11. Do not make over torque when mounting screws. Much mounting torque may cause DBC cracks, as well as bolts and Al heat - sink destruction.
- 12. Avoid one side tightening stress. Figure 10 shows the recommended torque order for mounting screws. Uneven mounting can cause the ceramic substrate of the Motion SPM 3 product to be damaged. The Pre - Screwing torque is set to 20 ~ 30% of maximum torque rating.

### Time Charts of SPMs Protective Function



**Figure 11. Under-Voltage Protection (Low-Side)**

- a1 : Control supply voltage rises: After the voltage rises  $UV_{CCR}$ , the circuits start to operate when next input is applied.
- a2 : Normal operation: IGBT ON and carrying current.
- a3 : Under voltage detection ( $UV_{CCD}$ ).
- a4 : IGBT OFF in spite of control input condition.
- a5 : Fault output operation starts fixed pulse width or until control supply voltage is recovered up to  $UV_{CCR}$ .
- a6 : Under voltage reset ( $UV_{CCR}$ ).
- a7 : Normal operation: IGBT ON and carrying current by triggering next signal from "LOW" to "HIGH".

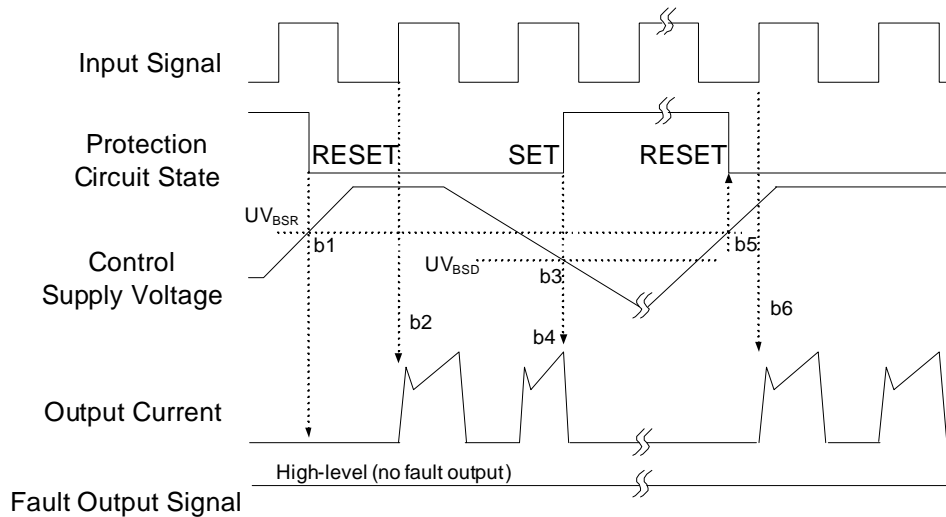

**Figure 12. Under-Voltage Protection (High-Side)**

- b1 : Control supply voltage rises: After the voltage reaches  $UV_{BSR}$ , the circuits start to operate when next input is applied.
- b2 : Normal operation: IGBT ON and carrying current.
- b3 : Under voltage detection ( $UV_{BSD}$ ).
- b4 : IGBT OFF in spite of control input condition, but there is no fault output signal.
- b5 : Under voltage reset ( $UV_{BSR}$ ).
- b6 : Normal operation: IGBT ON and carrying current by triggering next signal from "LOW" to "HIGH".

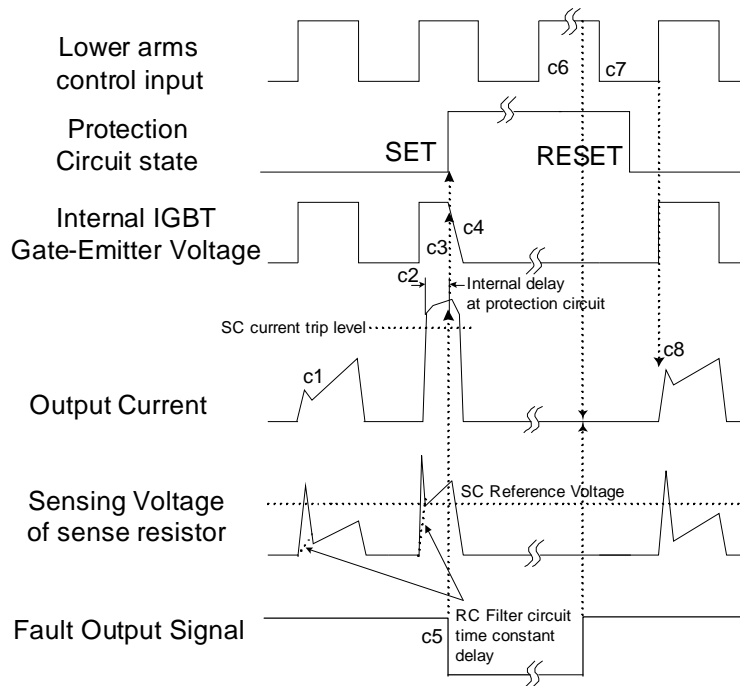
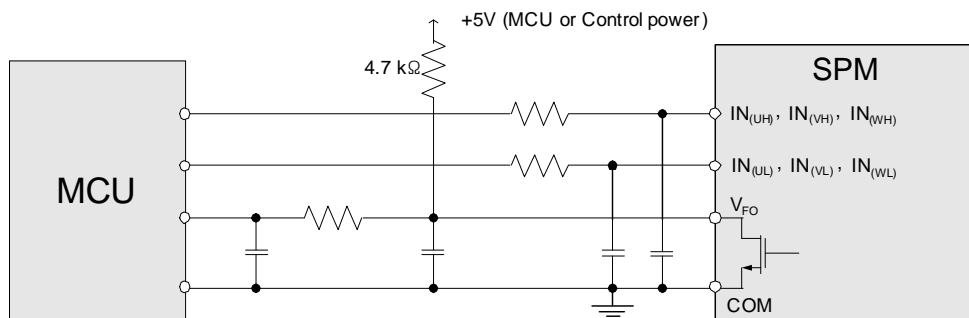

**Figure 13. Short-Circuit Current Protection (Low-Side Operation only)**

(with the external sense resistance and RC filter connection)

- c1 : Normal operation: IGBT ON and carrying current.
- c2 : Short circuit current detection (SC trigger).
- c3 : All low-side IGBT's gate are hard interrupted.
- c4 : All low-side IGBTs turn OFF.
- c5 : Fault output operation starts with a fixed pulse width.
- c6 : Input "HIGH": IGBT ON state, but during the active period of fault output the IGBT doesn't turn ON.
- c7 : Fault output operation finishes, but IGBT don't turn on until triggering next signal from "LOW" to "HIGH".
- c8 : Normal operation: IGBT ON and carrying current.

### Input/Output Interface Circuit



**Figure 14. Recommended CPU I/O Interface Circuit**

**Note:**

13. RC coupling at each input (parts shown dotted) might change depending on the PWM control scheme used in the application and the wiring impedance of the application's printed circuit board. The input signal section of the Motion SPM 3 product integrates 5 kΩ (typ.) pull - down resistor. Therefore, when using an external filtering resistor, please pay attention to the signal voltage drop at input terminal.

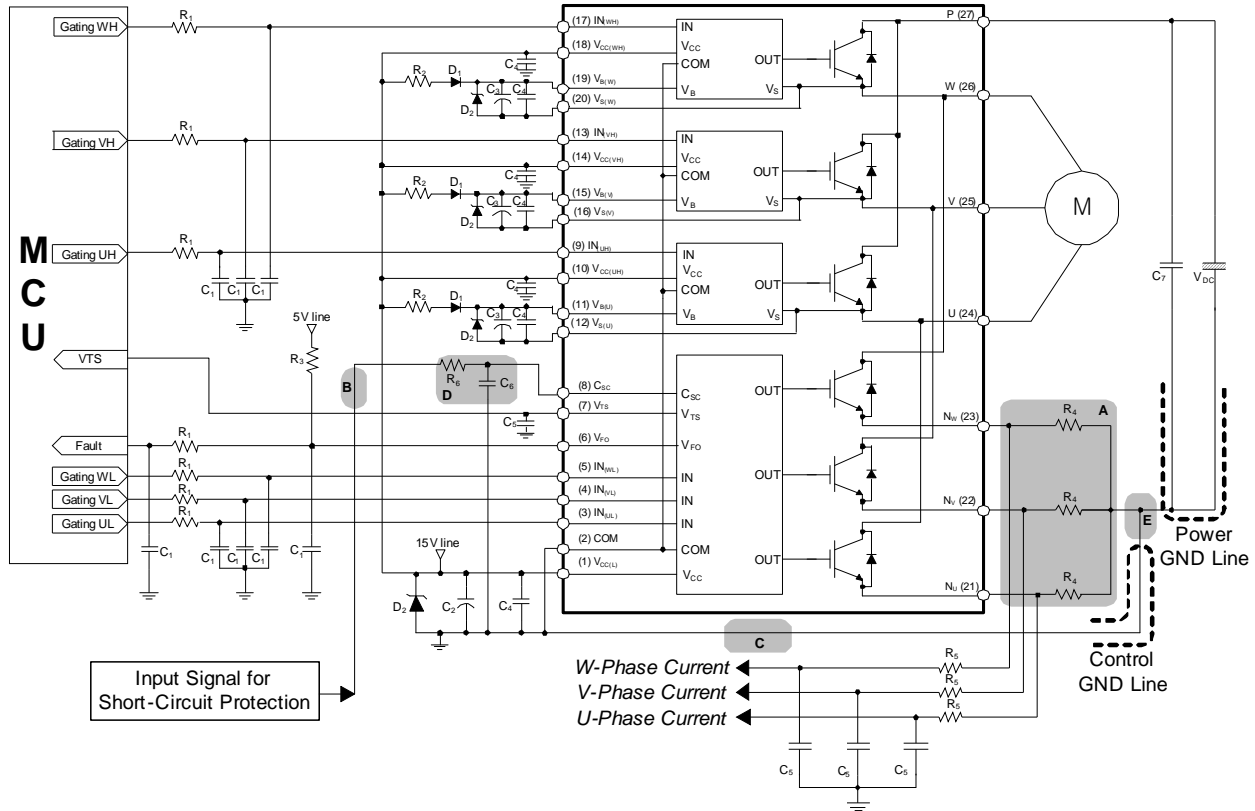
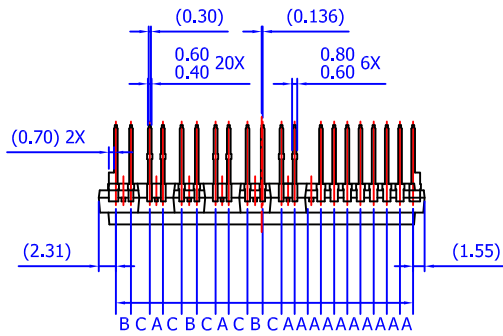

Figure 15. Typical Application Circuit

Note:

14. To avoid malfunction, the wiring of each input should be as short as possible. (less than 2 - 3 cm)
15.  $V_{FO}$  output is open-drain type. This signal line should be pulled up to the positive side of the MCU or control power supply with a resistor that makes  $I_{FO}$  up to 2 mA. Please refer to Figure 14.
16. Input signal is active-HIGH type. There is a 5 k $\Omega$  resistor inside the IC to pull-down each input signal line to GND. RC coupling circuits should be adopted for the prevention of input signal oscillation.  $R_1C_1$  time constant should be selected in the range 50 ~ 150 ns. (Recommended  $R_1 = 100 \Omega$ ,  $C_1 = 1$  nF)
17. Each wiring pattern inductance of A point should be minimized (Recommend less than 10nH). Additionally, it is recommended to use the shunt resistor  $R_4$  of surface mounted (SMD) type to reduce wiring inductance. To prevent malfunction, wiring of E point should be connected to the terminal of the shunt resistor  $R_4$  as close as possible.
18. To prevent errors of the protection function, the wiring of B, C, and D point should be as short as possible.
19. In the short - circuit protection circuit, please select the  $R_6C_6$  time constant in the range 1.5 ~ 2  $\mu$ s.  $R_6$  should be selected min. 10 times larger resistance than sense resistor  $R_5$ . And, It is recommended to do enough evaluation on the real system because short-circuit protection time may vary wiring pattern layout and value of the  $R_6C_6$  time constant.
20. Each capacitor should be mounted as close to the pins of the Motion SPM 3 product as possible.
21. To prevent surge destruction, the wiring between the smoothing capacitor  $C_7$  and the P & GND pins should be as short as possible. The use of a high frequency non - inductive capacitor of around 0.1 ~ 0.22  $\mu$ F between the P & GND pins is recommended.
22. Relays are used at almost every systems of electrical equipments at industrial application. In these cases, there should be sufficient distance between the CPU and the relays.
23. The zener diode or transient voltage suppressor should be adopted for the protection of ICs from the surge destruction between each pair of control supply terminals (Recommended zener diode is 22 V / 1 W, which has the lower zener impedance characteristic than about 15 $\Omega$ ).
24.  $C_2$  of around 7 times larger than bootstrap capacitor  $C_3$  is recommended.
25. Please choose the electrolytic capacitor with good temperature characteristic in  $C_3$ . Also, choose 0.1 ~ 0.2  $\mu$ F R - category ceramic capacitors with good temperature and frequency characteristics in  $C_4$ .



LEAD PITCH (TOLERANCE : ±0.30)  
 A : 1.778  
 B : 2.050  
 C : 2.531

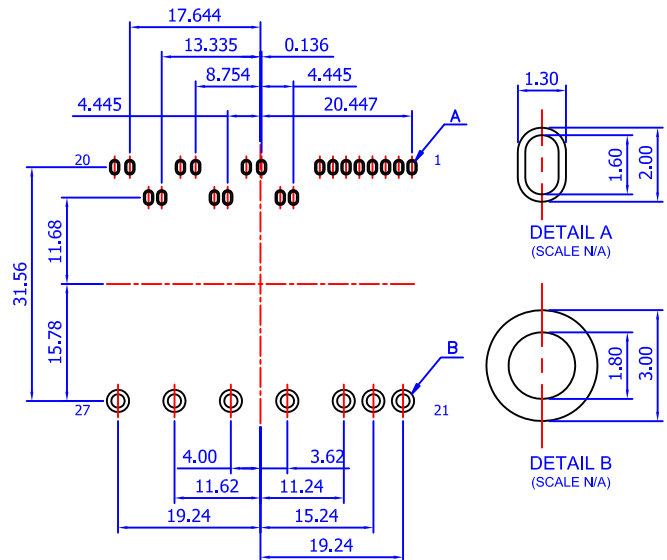
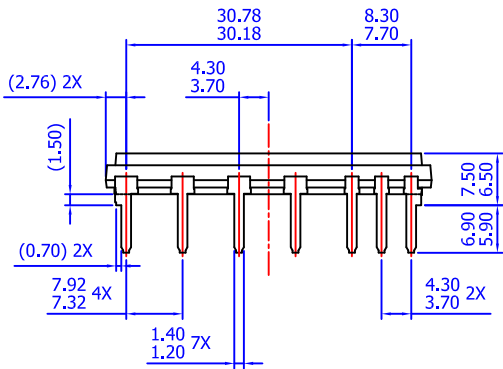
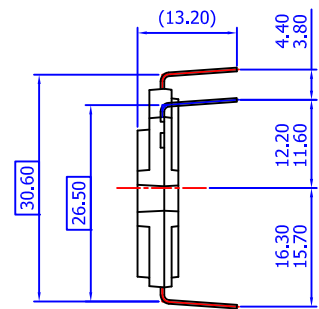
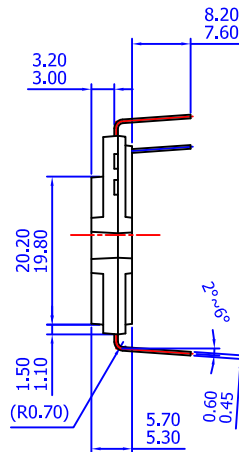
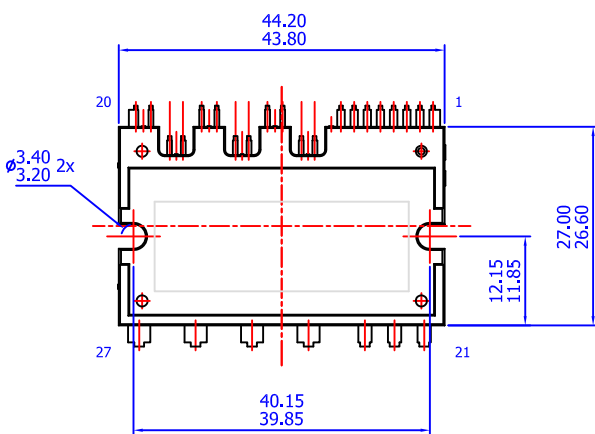

NOTES: UNLESS OTHERWISE SPECIFIED  
 A) THIS PACKAGE DOES NOT COMPLY TO ANY CURRENT PACKAGING STANDARD  
 B) ALL DIMENSIONS ARE IN MILLIMETERS  
 C) DIMENSIONS ARE EXCLUSIVE OF BURRS, MOLD FLASH, AND TIE BAR EXTRUSIONS  
 D) ( ) IS REFERENCE  
 E) [ ] IS ASSY QUALITY  
 F) DRAWING FILENAME: MOD27BAREV3  
 G) FAIRCHILD SEMICONDUCTOR

LAND PATTERN RECOMMENDATIONS



ON Semiconductor and  are trademarks of Semiconductor Components Industries, LLC dba ON Semiconductor or its subsidiaries in the United States and/or other countries. ON Semiconductor owns the rights to a number of patents, trademarks, copyrights, trade secrets, and other intellectual property. A listing of ON Semiconductor's product/patent coverage may be accessed at [www.onsemi.com/site/pdf/Patent-Marking.pdf](http://www.onsemi.com/site/pdf/Patent-Marking.pdf). ON Semiconductor reserves the right to make changes without further notice to any products herein. ON Semiconductor makes no warranty, representation or guarantee regarding the suitability of its products for any particular purpose, nor does ON Semiconductor assume any liability arising out of the application or use of any product or circuit, and specifically disclaims any and all liability, including without limitation special, consequential or incidental damages. Buyer is responsible for its products and applications using ON Semiconductor products, including compliance with all laws, regulations and safety requirements or standards, regardless of any support or applications information provided by ON Semiconductor. "Typical" parameters which may be provided in ON Semiconductor data sheets and/or specifications can and do vary in different applications and actual performance may vary over time. All operating parameters, including "Typicals" must be validated for each customer application by customer's technical experts. ON Semiconductor does not convey any license under its patent rights nor the rights of others. ON Semiconductor products are not designed, intended, or authorized for use as a critical component in life support systems or any FDA Class 3 medical devices or medical devices with a same or similar classification in a foreign jurisdiction or any devices intended for implantation in the human body. Should Buyer purchase or use ON Semiconductor products for any such unintended or unauthorized application, Buyer shall indemnify and hold ON Semiconductor and its officers, employees, subsidiaries, affiliates, and distributors harmless against all claims, costs, damages, and expenses, and reasonable attorney fees arising out of, directly or indirectly, any claim of personal injury or death associated with such unintended or unauthorized use, even if such claim alleges that ON Semiconductor was negligent regarding the design or manufacture of the part. ON Semiconductor is an Equal Opportunity/Affirmative Action Employer. This literature is subject to all applicable copyright laws and is not for resale in any manner.

## PUBLICATION ORDERING INFORMATION

### LITERATURE FULFILLMENT:

Literature Distribution Center for ON Semiconductor  
19521 E. 32nd Pkwy, Aurora, Colorado 80011 USA  
**Phone:** 303-675-2175 or 800-344-3860 Toll Free USA/Canada  
**Fax:** 303-675-2176 or 800-344-3867 Toll Free USA/Canada  
**Email:** [orderlit@onsemi.com](mailto:orderlit@onsemi.com)

**N. American Technical Support:** 800-282-9855 Toll Free  
USA/Canada  
**Europe, Middle East and Africa Technical Support:**  
Phone: 421 33 790 2910  
**Japan Customer Focus Center**  
Phone: 81-3-5817-1050

**ON Semiconductor Website:** [www.onsemi.com](http://www.onsemi.com)  
**Order Literature:** <http://www.onsemi.com/orderlit>  
For additional information, please contact your local  
Sales Representative

## Looking for pricing, stock, or lifecycle information?

Click below to explore more details on WIN SOURCE:

-  [View FSBB10CH120D on WIN SOURCE](#)
-  [Fairchild/ON Semiconductor Information](#)

## Optimize Your Supply Chain with WIN SOURCE Solutions

-  Global Sourcing Solution
-  Obsolete Management
-  Cost Control Management
-  Shortage Management
-  Alternative Solution
-  Excess Inventory Management