



Is Now Part of



**ON Semiconductor®**

To learn more about ON Semiconductor, please visit our website at  
[www.onsemi.com](http://www.onsemi.com)

Please note: As part of the Fairchild Semiconductor integration, some of the Fairchild orderable part numbers will need to change in order to meet ON Semiconductor's system requirements. Since the ON Semiconductor product management systems do not have the ability to manage part nomenclature that utilizes an underscore (\_), the underscore (\_) in the Fairchild part numbers will be changed to a dash (-). This document may contain device numbers with an underscore (\_). Please check the ON Semiconductor website to verify the updated device numbers. The most current and up-to-date ordering information can be found at [www.onsemi.com](http://www.onsemi.com). Please email any questions regarding the system integration to [Fairchild\\_questions@onsemi.com](mailto:Fairchild_questions@onsemi.com).

ON Semiconductor and the ON Semiconductor logo are trademarks of Semiconductor Components Industries, LLC dba ON Semiconductor or its subsidiaries in the United States and/or other countries. ON Semiconductor owns the rights to a number of patents, trademarks, copyrights, trade secrets, and other intellectual property. A listing of ON Semiconductor's product/patent coverage may be accessed at [www.onsemi.com/site/pdf/Patent-Marking.pdf](http://www.onsemi.com/site/pdf/Patent-Marking.pdf). ON Semiconductor reserves the right to make changes without further notice to any products herein. ON Semiconductor makes no warranty, representation or guarantee regarding the suitability of its products for any particular purpose, nor does ON Semiconductor assume any liability arising out of the application or use of any product or circuit, and specifically disclaims any and all liability, including without limitation special, consequential or incidental damages. Buyer is responsible for its products and applications using ON Semiconductor products, including compliance with all laws, regulations and safety requirements or standards, regardless of any support or applications information provided by ON Semiconductor. "Typical" parameters which may be provided in ON Semiconductor data sheets and/or specifications can and do vary in different applications and actual performance may vary over time. All operating parameters, including "Typicals" must be validated for each customer application by customer's technical experts. ON Semiconductor does not convey any license under its patent rights nor the rights of others. ON Semiconductor products are not designed, intended, or authorized for use as a critical component in life support systems or any FDA Class 3 medical devices or medical devices with a same or similar classification in a foreign jurisdiction or any devices intended for implantation in the human body. Should Buyer purchase or use ON Semiconductor products for any such unintended or unauthorized application, Buyer shall indemnify and hold ON Semiconductor and its officers, employees, subsidiaries, affiliates, and distributors harmless against all claims, costs, damages, and expenses, and reasonable attorney fees arising out of, directly or indirectly, any claim of personal injury or death associated with such unintended or unauthorized use, even if such claim alleges that ON Semiconductor was negligent regarding the design or manufacture of the part. ON Semiconductor is an Equal Opportunity/Affirmative Action Employer. This literature is subject to all applicable copyright laws and is not for resale in any manner.



May 2016

Motion-SPM™

## FSB50825AB

### Smart Power Module (SPM®)

#### Features

- 250V  $R_{DS(on)}=0.45\Omega$  max) 3-phase FRFET inverter including high voltage integrated circuit (HVIC)
- 3 divided negative dc-link terminals for inverter current sensing applications
- HVIC for gate driving and undervoltage protection
- Optimized for low electromagnetic interference
- Isolation voltage rating of 1500Vrms for 1min.
- HVIC temperature sensing
- Embedded bootstrap diode in the package
- RoHS compliant

#### Applications

- Three-phase inverter driver for small power ac motor drives

#### General Description

FSB50825AB is a tiny smart power module (SPM®) based on FRFET technology as a compact inverter solution for small power motor drive applications such as fan motors and water suppliers. It is composed of 6 fast-recovery MOSFET (FRFET), and 3 half-bridge HVICs for FRFET gate driving. FSB50825AB provides low electromagnetic interference (EMI) characteristics with optimized switching speed. Moreover, since it employs FRFET as a power switch, it has much better ruggedness and larger safe operation area (SOA) than that of an IGBT-based power module or one-chip solution. The package is optimized for the thermal performance and compactness for the use in the built-in motor application and any other application where the assembly space is concerned. FSB50825AB is the best solution for the compact inverter providing the energy efficiency, compactness, and low electromagnetic interference.

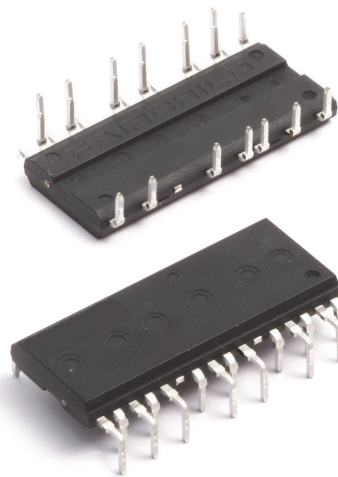

FSB50825AB Smart Power Module (SPM®)

## Absolute Maximum Ratings

### Inverter Part (Each FRFET Unless Otherwise Specified)

Symbol	Parameter	Conditions	Rating	Units
$V_{PN}$	DC Link Input Voltage, Drain-source Voltage of each FRFET		250	V
* $I_{D25}$	Each FRFET Drain Current, Continuous	$T_C = 25^\circ\text{C}$	3.6	A
* $I_{D80}$	Each FRFET Drain Current, Continuous	$T_C = 80^\circ\text{C}$	2.7	A
* $I_{DP}$	Each FRFET Drain Current, Peak	$T_C = 25^\circ\text{C}$ , $PW < 100\mu\text{s}$	9	A
* $I_{DRMS}$	Each FRFET Drain Current, Rms	$T_C = 80^\circ\text{C}$ , $F_{PWM} < 20\text{KHz}$	1.9	$A_{rms}$
* $P_D$	Maximum Power Dissipation	$T_C = 25^\circ\text{C}$ , For Each FRFET	14.2	W

### Control Part (Each HVIC Unless Otherwise Specified)

Symbol	Parameter	Conditions	Rating	Units
$V_{CC}$	Control Supply Voltage	Applied between $V_{CC}$ and COM	20	V
$V_{BS}$	High-side Bias Voltage	Applied between $V_B$ and $V_S$	20	V
$V_{IN}$	Input Signal Voltage	Applied between IN and COM	-0.3 ~ $V_{CC}+0.3$	V

### Bootstrap Diode Part (Each Bootstrap diode Unless Otherwise Specified)

Symbol	Parameter	Conditions	Rating	Units
$V_{RRMB}$	Maximum Repetitive Reverse Voltage		250	V
* $I_{FB}$	Forward Current	$T_C = 25^\circ\text{C}$	0.5	A
* $I_{FPB}$	Forward Current (Peak)	$T_C = 25^\circ\text{C}$ , Under 1ms Pulse Width	1.5	A

### Thermal Resistance

Symbol	Parameter	Conditions	Rating	Units
$R_{\theta JC}$	Junction to Case Thermal Resistance	Each FRFET under inverter operating condition (Note 1)	8.8	$^\circ\text{C/W}$

### Total System

Symbol	Parameter	Conditions	Rating	Units
$T_J$	Operating Junction Temperature		-40 ~ 150	$^\circ\text{C}$
$T_{STG}$	Storage Temperature		-40 ~ 125	$^\circ\text{C}$
$V_{ISO}$	Isolation Voltage	60Hz, Sinusoidal, 1 minute, Connection pins to heatsink	1500	$V_{rms}$

#### Note:

- For the measurement point of case temperature  $T_C$ , please refer to Figure 4.
- Marking "\*" is calculation value or design factor.

### Pin descriptions

Pin Number	Pin Name	Pin Description
1	COM	IC Common Supply Ground
2	$V_{B(U)}$	Bias Voltage for U Phase High Side FRFET Driving
3	$V_{CC(U)}$	Bias Voltage for U Phase IC and Low Side FRFET Driving
4	$IN_{(UH)}$	Signal Input for U Phase High-side
5	$IN_{(UL)}$	Signal Input for U Phase Low-side
6	N.C	N.C
7	$V_{B(V)}$	Bias Voltage for V Phase High Side FRFET Driving
8	$V_{CC(V)}$	Bias Voltage for V Phase IC and Low Side FRFET Driving
9	$IN_{(VH)}$	Signal Input for V Phase High-side
10	$IN_{(VL)}$	Signal Input for V Phase Low-side
11	N.C	N.C
12	$V_{B(W)}$	Bias Voltage for W Phase High Side FRFET Driving
13	$V_{CC(W)}$	Bias Voltage for W Phase IC and Low Side FRFET Driving
14	$IN_{(WH)}$	Signal Input for W Phase High-side
15	$IN_{(WL)}$	Signal Input for W Phase Low-side
16	$V_{ts}$	Output for HVIC temperature sensing
17	P	Positive DC-Link Input
18	U, $V_{S(U)}$	Output for U Phase & Bias Voltage Ground for High Side FRFET Driving
19	$N_U$	Negative DC-Link Input for U Phase
20	$N_V$	Negative DC-Link Input for V Phase
21	V, $V_{S(V)}$	Output for V Phase & Bias Voltage Ground for High Side FRFET Driving
22	$N_W$	Negative DC-Link Input for W Phase
23	W, $V_{S(W)}$	Output for W Phase & Bias Voltage Ground for High Side FRFET Driving

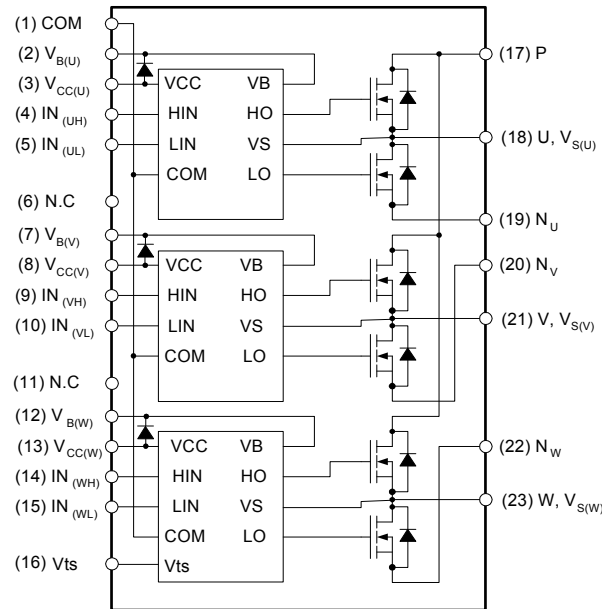

**Note:**

Source terminal of each low-side MOSFET is not connected to supply ground or bias voltage ground inside SPM®. External connections should be made as indicated in Figure 3

**Figure 1. Pin Configuration and Internal Block Diagram (Bottom View)**

## Electrical Characteristics (T<sub>J</sub> = 25°C, V<sub>CC</sub>=V<sub>BS</sub>=15V Unless Otherwise Specified)

### Inverter Part (Each FRFET Unless Otherwise Specified)

Symbol	Parameter	Conditions	Min	Typ	Max	Units
BV <sub>DSS</sub>	Drain-Source Breakdown Voltage	V <sub>IN</sub> = 0V, I <sub>D</sub> = 1mA (Note 1)	250	-	-	V
I <sub>DSS</sub>	Zero Gate Voltage Drain Current	V <sub>IN</sub> = 0V, V <sub>DS</sub> = 250V	-	-	1	mA
R <sub>DS(on)</sub>	Static Drain-Source On-Resistance	V <sub>CC</sub> = V <sub>BS</sub> = 15V, V <sub>IN</sub> = 5V, I <sub>D</sub> = 2A	-	0.33	0.45	Ω
V <sub>SD</sub>	Drain-Source Diode Forward Voltage	V <sub>CC</sub> = V <sub>BS</sub> = 15V, V <sub>IN</sub> = 0V, I <sub>D</sub> = -2A	-	-	1.2	V
t <sub>ON</sub>	Switching Times	V <sub>PN</sub> = 150V, V <sub>CC</sub> = V <sub>BS</sub> = 15V, I <sub>D</sub> = 2A V <sub>IN</sub> = 0V ←5V, Inductive load L=3mH High- and low-side FRFET switching (Note 2)	-	950	-	ns
t <sub>OFF</sub>			-	520	-	ns
t <sub>tr</sub>			-	140	-	ns
E <sub>ON</sub>			-	100	-	μJ
E <sub>OFF</sub>			-	10	-	μJ
RBSOA	Reverse-bias Safe Operating Area	V <sub>PN</sub> = 200V, V <sub>CC</sub> = V <sub>BS</sub> = 15V, I <sub>D</sub> = I <sub>DP</sub> , V <sub>DS</sub> =BV <sub>DSS</sub> , T <sub>J</sub> = 150°C High- and low-side FRFET switching (Note 3)	Full Square			

### Control Part (Each HVIC Unless Otherwise Specified)

Symbol	Parameter	Conditions	Min	Typ	Max	Units
I <sub>QCC</sub>	Quiescent V <sub>CC</sub> Current	V <sub>CC</sub> =15V, V <sub>IN</sub> =0V Applied between V <sub>CC</sub> and COM	-	-	200	μA
I <sub>QBS</sub>	Quiescent V <sub>BS</sub> Current	V <sub>BS</sub> =15V, V <sub>IN</sub> =0V Applied between V <sub>B(U)</sub> -U, V <sub>B(V)</sub> -V, V <sub>B(W)</sub> -W	-	-	100	μA
UV <sub>CCD</sub>	Low-side Undervoltage Protection (Figure 8)	V <sub>CC</sub> Undervoltage Protection Detection Level	7.4	8.0	9.4	V
UV <sub>CCR</sub>		V <sub>CC</sub> Undervoltage Protection Reset Level	8.0	8.9	9.8	V
UV <sub>BSD</sub>	High-side Undervoltage Protection (Figure 9)	V <sub>BS</sub> Undervoltage Protection Detection Level	7.4	8.0	9.4	V
UV <sub>BSR</sub>		V <sub>BS</sub> Undervoltage Protection Reset Level	8.0	8.9	9.8	V
V <sub>ts</sub>	HVIC Temperature sensing voltage output	V <sub>CC</sub> =15V, T <sub>HVIC</sub> =25°C(Note 4)	600	790	980	mV
V <sub>IH</sub>	ON Threshold Voltage	Logic High Level	-	-	2.9	V
V <sub>IL</sub>	OFF Threshold Voltage	Logic Low Level	0.8	-	-	V

### Bootstrap Diode Part (Each Bootstrap diode Unless Otherwise Specified)

Symbol	Parameter	Conditions	Min	Typ	Max	Units
V <sub>FB</sub>	Forward Voltage	I <sub>F</sub> = 0.1A, T <sub>C</sub> = 25°C(Note 5)	-	2.5	-	V
t <sub>rrB</sub>	Reverse Recovery Time	I <sub>F</sub> = 0.1A, T <sub>C</sub> = 25°C	-	80	-	ns

**Note:**

- BV<sub>DSS</sub> is the absolute maximum voltage rating between drain and source terminal of each FRFET inside SPM®. V<sub>PN</sub> should be sufficiently less than this value considering the effect of the stray inductance so that V<sub>DS</sub> should not exceed BV<sub>DSS</sub> in any case.
- t<sub>ON</sub> and t<sub>OFF</sub> include the propagation delay time of the internal drive IC. Listed values are measured at the laboratory test condition, and they can be different according to the field applications due to the effect of different printed circuit boards and wirings. Please see Figure 6 for the switching time definition with the switching test circuit of Figure 7.
- The peak current and voltage of each FRFET during the switching operation should be included in the safe operating area (SOA). Please see Figure 7 for the RBSOA test circuit that is same as the switching test circuit.
- V<sub>ts</sub> is only for sensing temperature of module and cannot shutdown MOSFETs automatically.
- Built in bootstrap diode includes around 15Ω resistance characteristic. Please refer to Figure 2.

### Recommended Operating Condition

Symbol	Parameter	Conditions	Value			Units
			Min.	Typ.	Max.	
$V_{PN}$	Supply Voltage	Applied between P and N	-	150	200	V
$V_{CC}$	Control Supply Voltage	Applied between $V_{CC}$ and COM	12	13.5	15	V
$V_{BS}$	High-side Bias Voltage	Applied between $V_B$ and $V_S$	12	13.5	15	V
$V_{IN(ON)}$	Input ON Threshold Voltage	Applied between IN and COM	3.0	-	$V_{CC}$	V
$V_{IN(OFF)}$	Input OFF Threshold Voltage		0	-	0.6	V
$t_{dead}$	Blanking Time for Preventing Arm-short	$V_{CC}=V_{BS}=12 \sim 15V, T_J \leq 150^\circ C$	1.0	-	-	$\mu s$
$f_{PWM}$	PWM Switching Frequency	$T_J \leq 150^\circ C$	-	15	-	kHz

### Package Marking & Ordering Information

Device Marking	Device	Package	Reel Size	Packing Type	Quantity
FSB50825AB	FSB50825AB	SPM23DD-21L	-	-	15

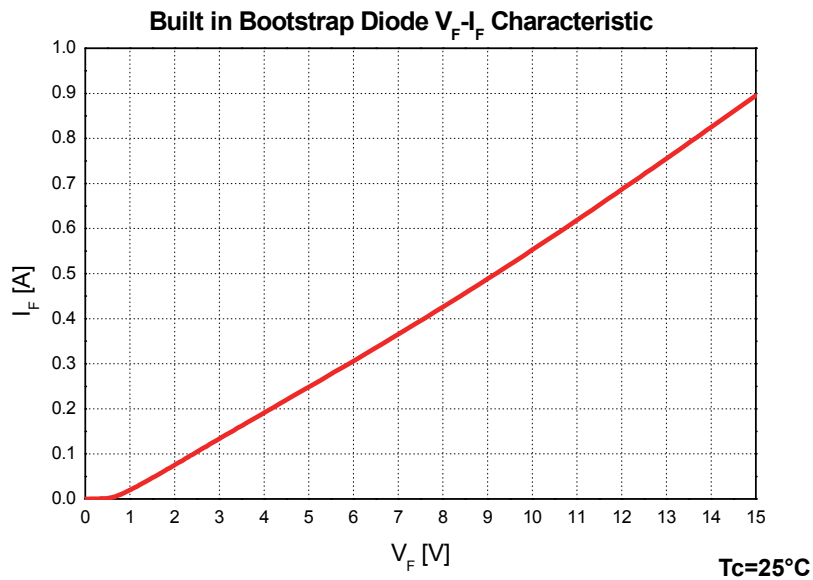

**Figure 2. Built in Bootstrap Diode Characteristics(typ.)**

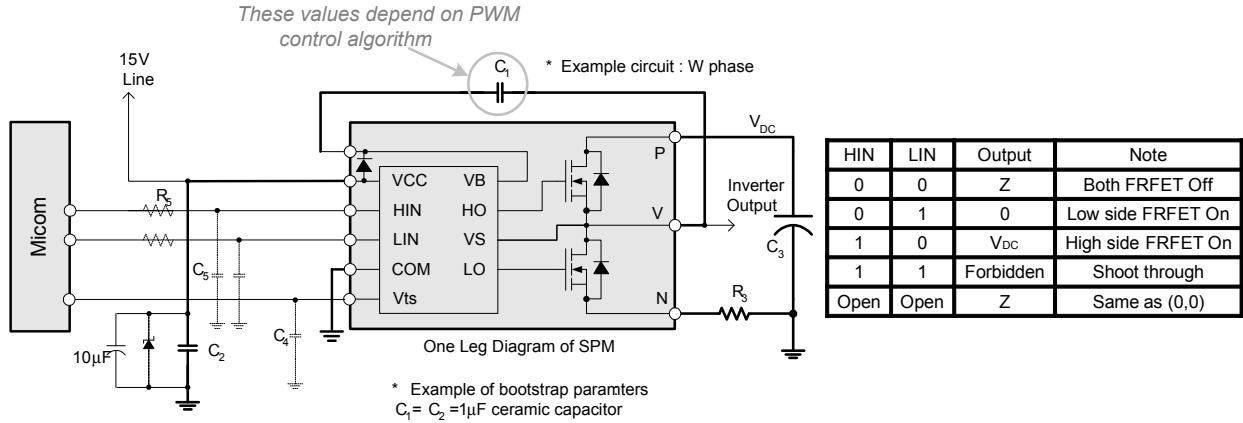

**Note:**

- Parameters for bootstrap circuit elements are dependent on PWM algorithm. For 15 kHz of switching frequency, typical example of parameters is shown above.
- RC coupling (R<sub>5</sub> and C<sub>5</sub>) and C<sub>4</sub> at each input of SPM® and Microm (indicated as dotted lines) may be used to prevent improper signal due to surge noise.
- Bold lines should be short and thick in PCB pattern to have small stray inductance of circuit, which results in the reduction of surge voltage. Bypass capacitors such as C<sub>1</sub>, C<sub>2</sub> and C<sub>3</sub> should have good high-frequency characteristics to absorb high-frequency ripple current.

**Figure 3. Recommended CPU Interface and Bootstrap Circuit with Parameters**

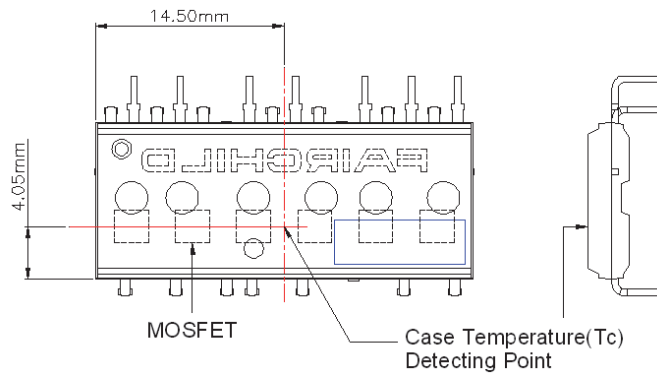

**Note:**

Attach the thermocouple on top of the heatsink-side of SPM® (between SPM® and heatsink if applied) to get the correct temperature measurement.

**Figure 4. Case Temperature Measurement**

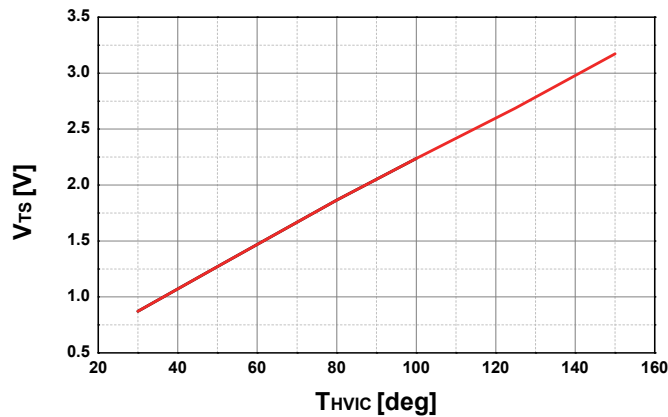

**Figure 5. Temperature profile of V<sub>ts</sub>(typ.)**

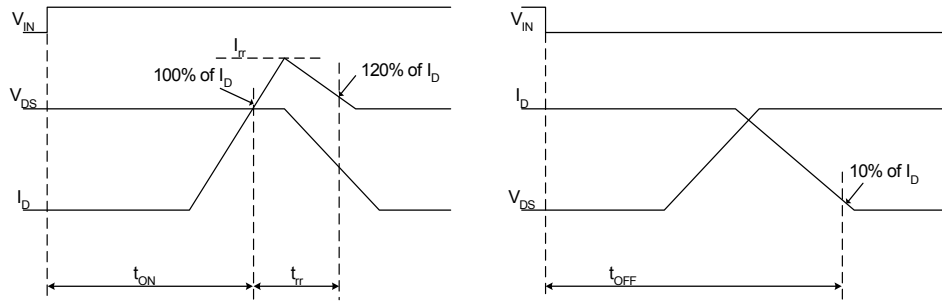

(a) Turn-on (b) Turn-off  
**Figure 6. Switching Time Definition**

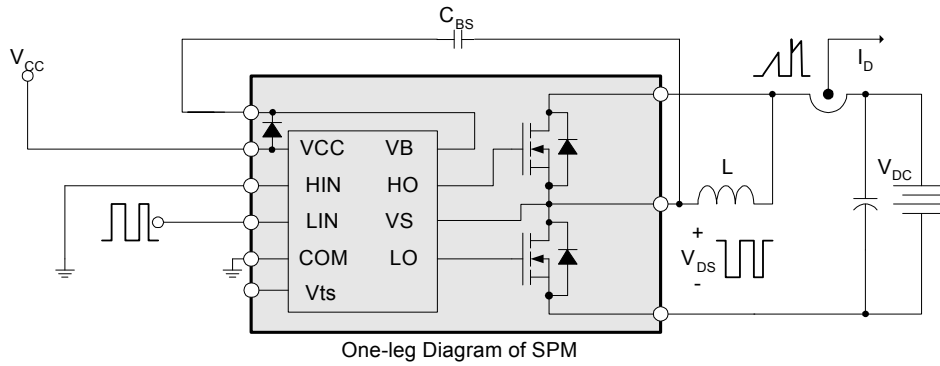

**Figure 7. Switching and RBSOA(Single-pulse) Test Circuit (Low-side)**

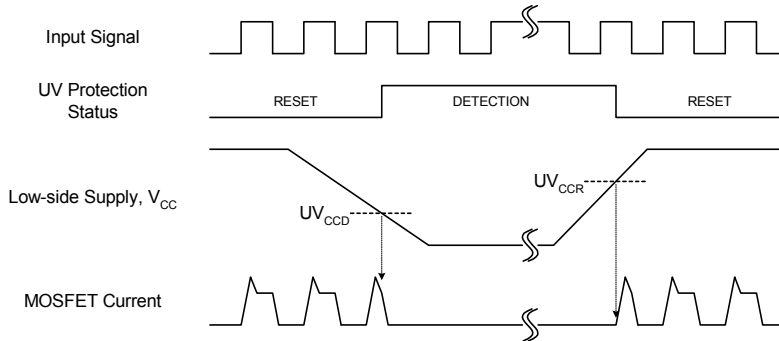

**Figure 8. Undervoltage Protection (Low-side)**

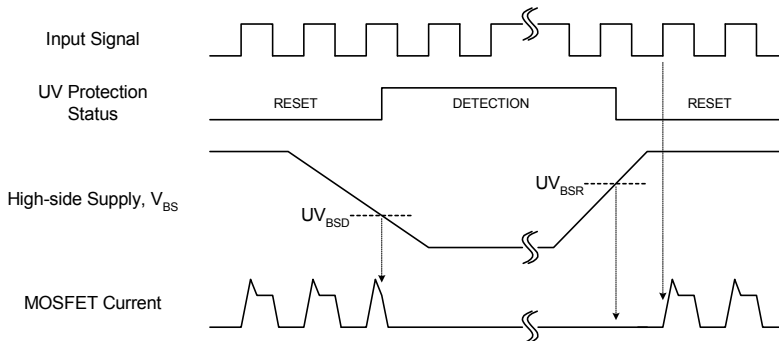

**Figure 9. Undervoltage Protection (High-side)**

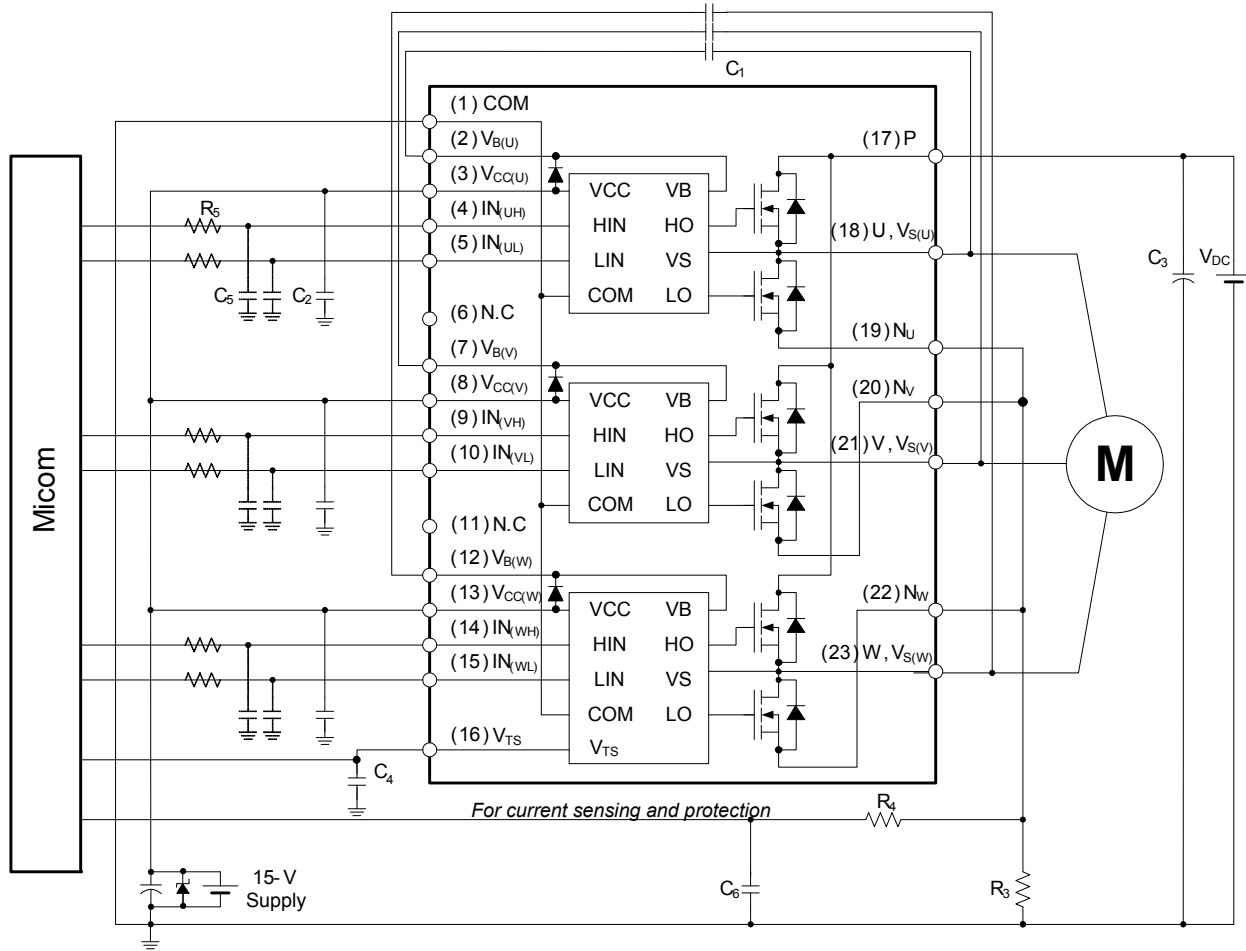

**Note:**

1. About pin position, refer to Figure 2.
2. RC coupling(R<sub>5</sub> and C<sub>5</sub>, R<sub>4</sub> and C<sub>6</sub>) and C<sub>4</sub> at each input of SPM® and Microm are useful to prevent improper input signal caused by surge noise.
3. The voltage drop across R<sub>3</sub> affects the low side switching performance and the bootstrap characteristics since it is placed between COM and the source terminal of the low side MOSFET. For this reason, the voltage drop across R<sub>3</sub> should be less than 1V in the steady-state.
4. Ground wires and output terminals, should be thick and short in order to avoid surge voltage and malfunction of HVIC.
5. All the filter capacitors should be connected close to SPM®, and they should have good characteristics for rejecting high-frequency ripple current.

**Figure 10. Example of Application Circuit**

### Detailed Package Outline Drawings

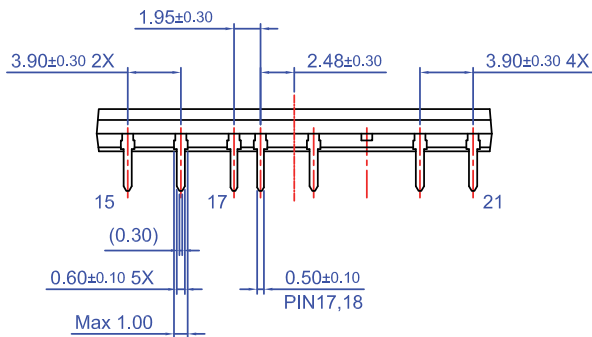
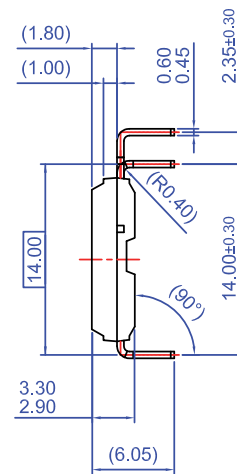
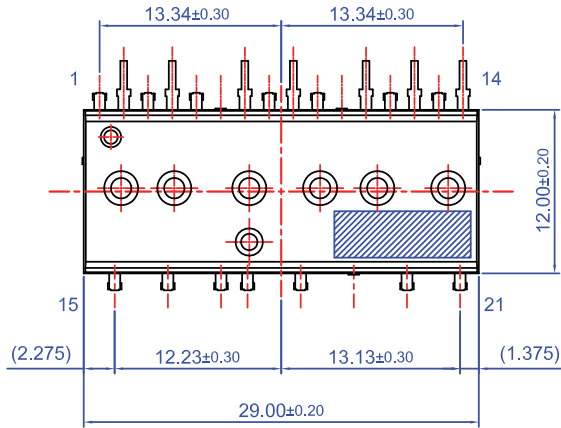
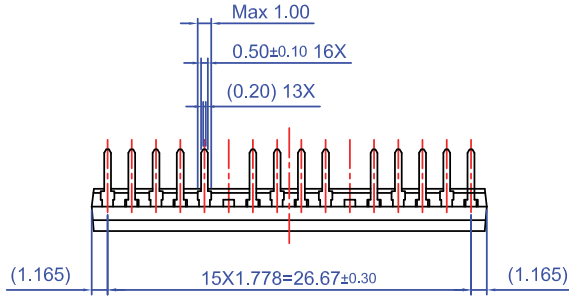

- NOTES: UNLESS OTHERWISE SPECIFIED  
 A) THIS PACKAGE DOES NOT COMPLY TO ANY CURRENT PACKAGING STANDARD  
 B) ALL DIMENSIONS ARE IN MILLIMETERS  
 C) DIMENSIONS ARE EXCLUSIVE OF BURRS, MOLD FLASH, AND TIE BAR EXTRUSIONS  
 D) ( ) IS REFERENCE  
 E) DRAWING FILENAME: MOD21DAREV2.0  
 F) FAIRCHILD SEMICONDUCTOR





**TRADEMARKS**

The following includes registered and unregistered trademarks and service marks, owned by Fairchild Semiconductor and/or its global subsidiaries, and is not intended to be an exhaustive list of all such trademarks.

- |                          |  |                                       |                  |
|--------------------------|--|---------------------------------------|------------------|
| AccuPower™               | F-PFS™   | OPTOPLANAR®                           | SYSTEM GENERAL®  |
| AttitudeEngine™          | FRFET®   |                                       | TinyBoost®       |
| Awinda®                  | Global Power Resource™                         | Power Supply WebDesigner™             | TinyBuck®        |
| AX-CAP®*                 | GreenBridge™                                   | PowerTrench®                          | TinyCalc™        |
| BitSiC™                  | Green FPS™                                     | PowerXS™                              | TinyLogic™       |
| Build it Now™            | Green FPS™ e-Series™                           | Programmable Active Droop™            | TINYOPTO™        |
| CorePLUS™                | Gmax™  | QFET®                                 | TinyPower™       |
| CorePOWER™               | GTO™   | QS™                                   | TinyPWM™         |
| CROSSVOLT™               | IntelliMAX™                                    | Quiet Series™                         | TinyWire™        |
| CTL™                     | ISOPLANAR™                                     | RapidConfigure™                       | TransiC™         |
| Current Transfer Logic™  | Making Small Speakers Sound Louder and Better™ |                                       | TriFault Detect™ |
| DEUXPEED®                | MegaBuck™                                      | Saving our world, 1mW/W/kW at a time™ | TRUECURRENT®*    |
| Dual Cool™               | MICROCOUPLER™                                  | SignalWise™                           | µSerDes™         |
| EcoSPARK®                | MicroFET™                                      | SmartMax™                             |                  |
| EfficientMax™            | MicroPak™                                      | SMART START™                          | SerDes™          |
| ESBC™                    | MicroPak2™                                     | Solutions for Your Success™           | UHC®             |
|                          | MillerDrive™                                   | SPM®                                  | Ultra FRFET™     |
| Fairchild®               | MotionMax™                                     | STEALTH™                              | UniFET™          |
| Fairchild Semiconductor® | MotionGrid®                                    | SuperFET®                             | VCX™             |
| FACT Quiet Series™       | MTI®   | SuperSOT™-3                           | VisualMax™       |
| FACT®                    | MTx®   | SuperSOT™-6                           | VoltagePlus™     |
| FastvCore™               | MVN®   | SuperSOT™-8                           | XS™              |
| FETBench™                | mWSaver®                                       | SupreMOS®                             | Xsens™           |
| FPS™                     | OptoHiT™                                       | SyncFET™                              | 仙童®              |
|                          | OPTOLOGIC®                                     | Sync-Lock™                            |                  |

\* Trademarks of System General Corporation, used under license by Fairchild Semiconductor.

**DISCLAIMER**

FAIRCHILD SEMICONDUCTOR RESERVES THE RIGHT TO MAKE CHANGES WITHOUT FURTHER NOTICE TO ANY PRODUCTS HEREIN TO IMPROVE RELIABILITY, FUNCTION, OR DESIGN. TO OBTAIN THE LATEST, MOST UP-TO-DATE DATASHEET AND PRODUCT INFORMATION, VISIT OUR WEBSITE AT [HTTP://WWW.FAIRCHILDSEMI.COM](http://www.fairchildsemi.com). FAIRCHILD DOES NOT ASSUME ANY LIABILITY ARISING OUT OF THE APPLICATION OR USE OF ANY PRODUCT OR CIRCUIT DESCRIBED HEREIN; NEITHER DOES IT CONVEY ANY LICENSE UNDER ITS PATENT RIGHTS, NOR THE RIGHTS OF OTHERS. THESE SPECIFICATIONS DO NOT EXPAND THE TERMS OF FAIRCHILD'S WORLDWIDE TERMS AND CONDITIONS, SPECIFICALLY THE WARRANTY THEREIN, WHICH COVERS THESE PRODUCTS.

**AUTHORIZED USE**

Unless otherwise specified in this data sheet, this product is a standard commercial product and is not intended for use in applications that require extraordinary levels of quality and reliability. This product may not be used in the following applications, unless specifically approved in writing by a Fairchild officer: (1) automotive or other transportation, (2) military/aerospace, (3) any safety critical application – including life critical medical equipment – where the failure of the Fairchild product reasonably would be expected to result in personal injury, death or property damage. Customer's use of this product is subject to agreement of this Authorized Use policy. In the event of an unauthorized use of Fairchild's product, Fairchild accepts no liability in the event of product failure. In other respects, this product shall be subject to Fairchild's Worldwide Terms and Conditions of Sale, unless a separate agreement has been signed by both Parties.

**ANTI-COUNTERFEITING POLICY**

Fairchild Semiconductor Corporation's Anti-Counterfeiting Policy. Fairchild's Anti-Counterfeiting Policy is also stated on our external website, [www.fairchildsemi.com](http://www.fairchildsemi.com), under Terms of Use

Counterfeiting of semiconductor parts is a growing problem in the industry. All manufacturers of semiconductor products are experiencing counterfeiting of their parts. Customers who inadvertently purchase counterfeit parts experience many problems such as loss of brand reputation, substandard performance, failed applications, and increased cost of production and manufacturing delays. Fairchild is taking strong measures to protect ourselves and our customers from the proliferation of counterfeit parts. Fairchild strongly encourages customers to purchase Fairchild parts either directly from Fairchild or from Authorized Fairchild Distributors who are listed by country on our web page cited above. Products customers buy either from Fairchild directly or from Authorized Fairchild Distributors are genuine parts, have full traceability, meet Fairchild's quality standards for handling and storage and provide access to Fairchild's full range of up-to-date technical and product information. Fairchild and our Authorized Distributors will stand behind all warranties and will appropriately address any warranty issues that may arise. Fairchild will not provide any warranty coverage or other assistance for parts bought from Unauthorized Sources. Fairchild is committed to combat this global problem and encourage our customers to do their part in stopping this practice by buying direct or from authorized distributors.

**PRODUCT STATUS DEFINITIONS**

**Definition of Terms**

Datasheet Identification	Product Status	Definition
Advance Information	Formative / In Design	Datasheet contains the design specifications for product development. Specifications may change in any manner without notice.
Preliminary	First Production	Datasheet contains preliminary data; supplementary data will be published at a later date. Fairchild Semiconductor reserves the right to make changes at any time without notice to improve design.
No Identification Needed	Full Production	Datasheet contains final specifications. Fairchild Semiconductor reserves the right to make changes at any time without notice to improve the design.
Obsolete	Not In Production	Datasheet contains specifications on a product that is discontinued by Fairchild Semiconductor. The datasheet is for reference information only.

Rev. I77

ON Semiconductor and  are trademarks of Semiconductor Components Industries, LLC dba ON Semiconductor or its subsidiaries in the United States and/or other countries. ON Semiconductor owns the rights to a number of patents, trademarks, copyrights, trade secrets, and other intellectual property. A listing of ON Semiconductor's product/patent coverage may be accessed at [www.onsemi.com/site/pdf/Patent-Marking.pdf](http://www.onsemi.com/site/pdf/Patent-Marking.pdf). ON Semiconductor reserves the right to make changes without further notice to any products herein. ON Semiconductor makes no warranty, representation or guarantee regarding the suitability of its products for any particular purpose, nor does ON Semiconductor assume any liability arising out of the application or use of any product or circuit, and specifically disclaims any and all liability, including without limitation special, consequential or incidental damages. Buyer is responsible for its products and applications using ON Semiconductor products, including compliance with all laws, regulations and safety requirements or standards, regardless of any support or applications information provided by ON Semiconductor. "Typical" parameters which may be provided in ON Semiconductor data sheets and/or specifications can and do vary in different applications and actual performance may vary over time. All operating parameters, including "Typicals" must be validated for each customer application by customer's technical experts. ON Semiconductor does not convey any license under its patent rights nor the rights of others. ON Semiconductor products are not designed, intended, or authorized for use as a critical component in life support systems or any FDA Class 3 medical devices or medical devices with a same or similar classification in a foreign jurisdiction or any devices intended for implantation in the human body. Should Buyer purchase or use ON Semiconductor products for any such unintended or unauthorized application, Buyer shall indemnify and hold ON Semiconductor and its officers, employees, subsidiaries, affiliates, and distributors harmless against all claims, costs, damages, and expenses, and reasonable attorney fees arising out of, directly or indirectly, any claim of personal injury or death associated with such unintended or unauthorized use, even if such claim alleges that ON Semiconductor was negligent regarding the design or manufacture of the part. ON Semiconductor is an Equal Opportunity/Affirmative Action Employer. This literature is subject to all applicable copyright laws and is not for resale in any manner.

## PUBLICATION ORDERING INFORMATION

### LITERATURE FULFILLMENT:



Literature Distribution Center for ON Semiconductor  
19521 E. 32nd Pkwy, Aurora, Colorado 80011 USA  
**Phone:** 303-675-2175 or 800-344-3860 Toll Free USA/Canada  
**Fax:** 303-675-2176 or 800-344-3867 Toll Free USA/Canada  
**Email:** [orderlit@onsemi.com](mailto:orderlit@onsemi.com)

**N. American Technical Support:** 800-282-9855 Toll Free  
USA/Canada  
**Europe, Middle East and Africa Technical Support:**  
Phone: 421 33 790 2910  
**Japan Customer Focus Center**  
Phone: 81-3-5817-1050

**ON Semiconductor Website:** [www.onsemi.com](http://www.onsemi.com)  
**Order Literature:** <http://www.onsemi.com/orderlit>  
For additional information, please contact your local  
Sales Representative

## Looking for pricing, stock, or lifecycle information?

Click below to explore more details on WIN SOURCE:

-  [View FSB50825AB on WIN SOURCE](#)
-  [Fairchild/ON Semiconductor Information](#)

## Optimize Your Supply Chain with WIN SOURCE Solutions

-  Global Sourcing Solution
-  Obsolete Management
-  Cost Control Management
-  Shortage Management
-  Alternative Solution
-  Excess Inventory Management