



# THE DATASHEET OF FAN8200MTCX



# FAN8200/FAN8200D/FAN8200MTC FAN8200MP

## Low Voltage/Low Saturation Stepping Motor Driver

### Features

- 3.3V and 5V MPU interface
- Dual H-bridge drivers for bipolar stepping motor drives
- Built-in vertical-PNP power transistors
- Wide supply voltage range (VCC = 2.5V ~ 7.0V)
- Low saturation voltage (0.4V@ 0.4A)
- Built-in chip enable function for each bridge
- Built-in shoot-through current protection
- Built-in thermal shutdown(TSD) function

### Description

The FAN8200/FAN8200D/FAN8200MTC/FAN8200MP is a monolithic integrated circuit designed for two-phase stepping motor drive systems. It has dual H-bridge drivers with vertical-PNP power transistors. Each of the bridges has an independent enable pin, therefore it can be used for other applications as well as stepping motor drive systems.

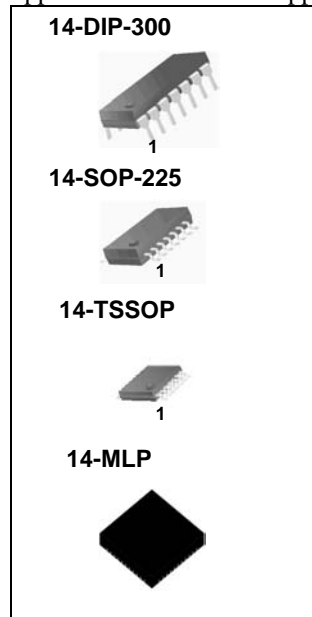

### Typical Application

- General low voltage stepping motor driver
- Floppy disk driver
- Camera stepping motor driver
- PC camera or security equipment motion controller
- Two channel DC motor driver for a digital still camera (DSC)
- MPU interfaced general power driver (buffer)

### Ordering Information

Device	Package	Operating Temp.
FAN8200	14-DIP-300	-20 ~ +75°C
FAN8200D	14-SOP-225	-20 ~ +75°C
FAN8200DTF	14-SOP-225	-20 ~ +75°C
FAN8200MTC	14-TSSOP	-20 ~ +75°C
FAN8200MTCX	14-TSSOP	-20 ~ +75°C
FAN8200MPX	14-MLP	-30 ~ +80°C

## Pin Assignments

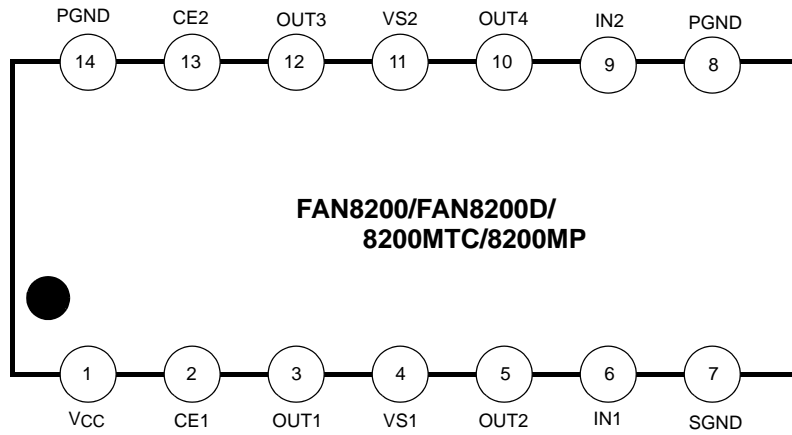

## Pin Definitions

Pin Number	Pin Name	I/O	Pin Function Description
1	VCC	-	Logic part supply voltage
2	CE1	I	Chip enable 1
3	OUT1	O	Output 1
4	VS1	-	Power supply 1
5	OUT2	O	Output 2
6	IN1	I	Input 1
7	SGND	-	Signal ground
8	PGND	-	Power ground
9	IN2	I	Input 2
10	OUT4	O	Output 4
11	VS2	-	Power supply 2
12	OUT3	O	Output 3
13	CE2	I	Chip enable 2
14	PGND	-	Power ground

# Internal Block Diagram

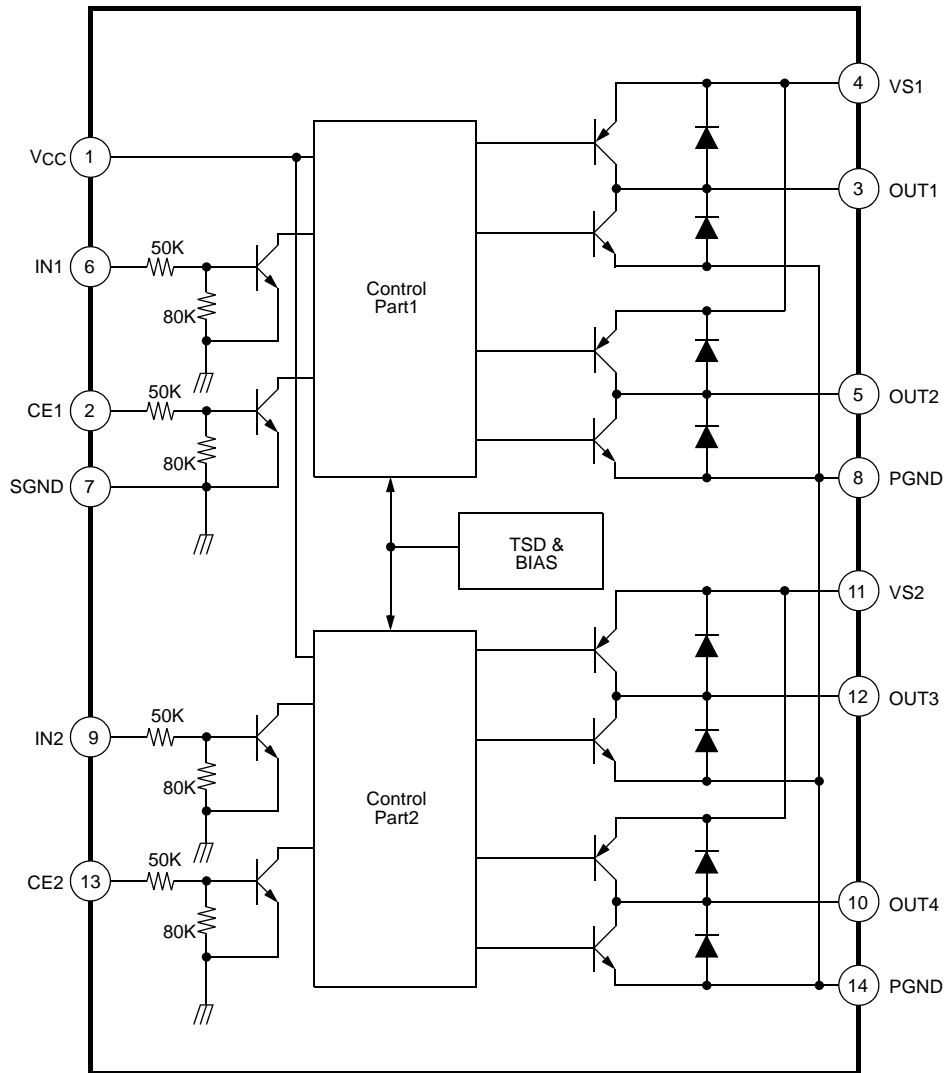

## Absolute Maximum Ratings (Ta = 25°C)

Parameter	Symbol	Value	Unit
Supply voltage	VCC(MAX)	9.0	V
Power supply voltage	VS(MAX)	9.0	V
Output voltage	VOUT(MAX)	VS + VCF	V
Input voltage	VIN(MAX)	7.0	V
Peak output current per channel	IO(PEAK)	1	A
Continuous output current per channel	IO	0.65 (FAN8200) 0.4 (FAN8200D) 0.55 (FAN8200MTC) 0.35 (FAN8200MP)	A
Power dissipation	PD <sup>note</sup>	1.0 (FAN8200) 0.6 (FAN8200D) 0.87 (FAN8200MTC) 0.8 (FAN8200MP)	W
Junction temperature	TJ	150	°C
Storage temperature	TSTG	-40 ~ 125	°C
Operating temperature	TA	-20 ~ 75(FAN8200) -20 ~ 75(FAN8200D) -20 ~ 75(FAN8200MTC) -30 ~ 80(FAN8200MP)	°C

**Notes:**

1. When mounted on 76.2mm × 114mm × 1.57mm PCB (glass epoxy material).
2. Power dissipation reduces 8.0mW/°C for FAN8200, 4.8mW/°C for FAN8200D, 6.9mW/°C for FAN8200MTC and 6.4mW/°C FAN8200MP for Ta ≥ 25°C.
3. Should not exceed PD and SOA(Safe Operating Area).

## Power Dissipation Curve

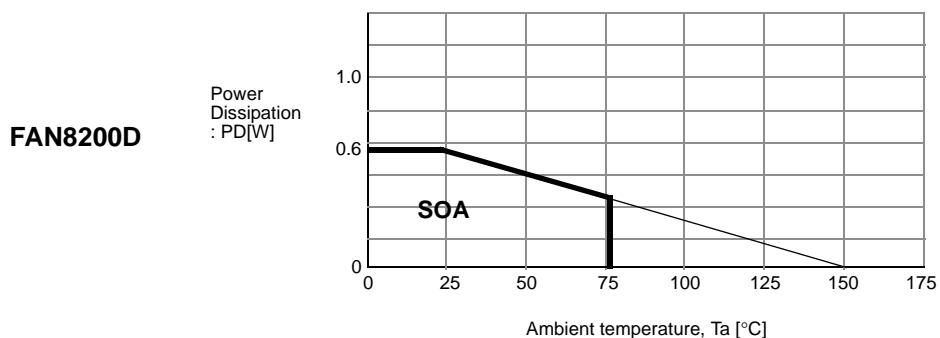
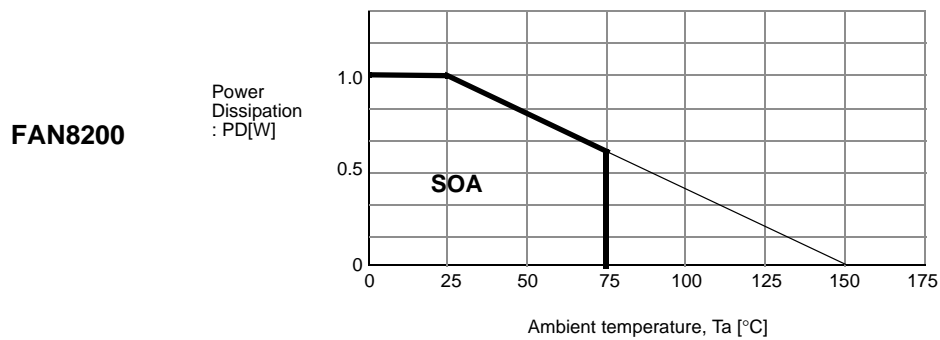

**Power Dissipation Curve** (Continued)

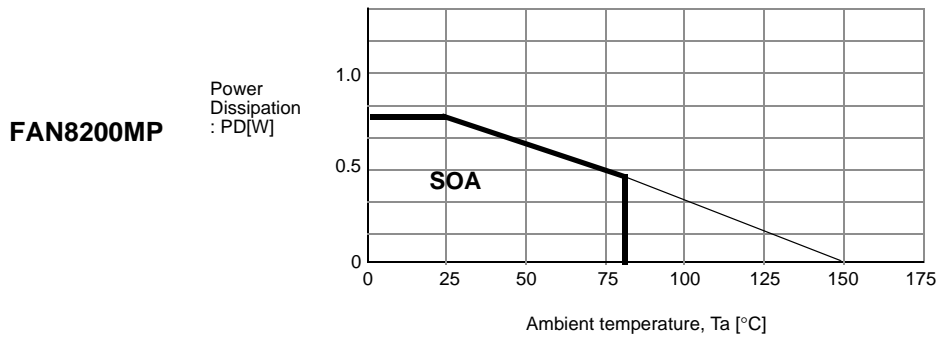
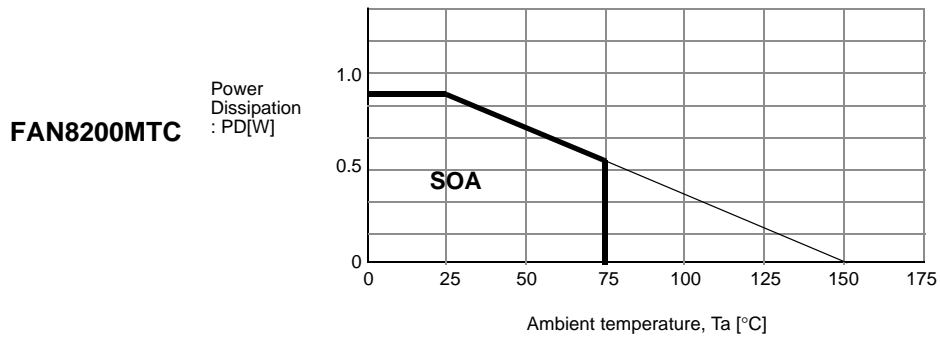

**Recommended Operating Conditions (Ta = 25°C)**

Parameter	Symbol	Min.	Typ.	Max	Unit
Logic circuit supply voltage	VCC	2.5	-	7.0	V
Power supply voltage	VS	2.5	-	7.0	V

## Function Descriptions

CE1	IN1	OUT1	OUT2	CE2	IN2	OUT3	OUT4
Low	X	Z	Z	Low	X	Z	Z
High	Low	High	Low	High	Low	High	Low
High	High	Low	High	High	High	Low	High

**X:** don't care

**Z:** high-impedance

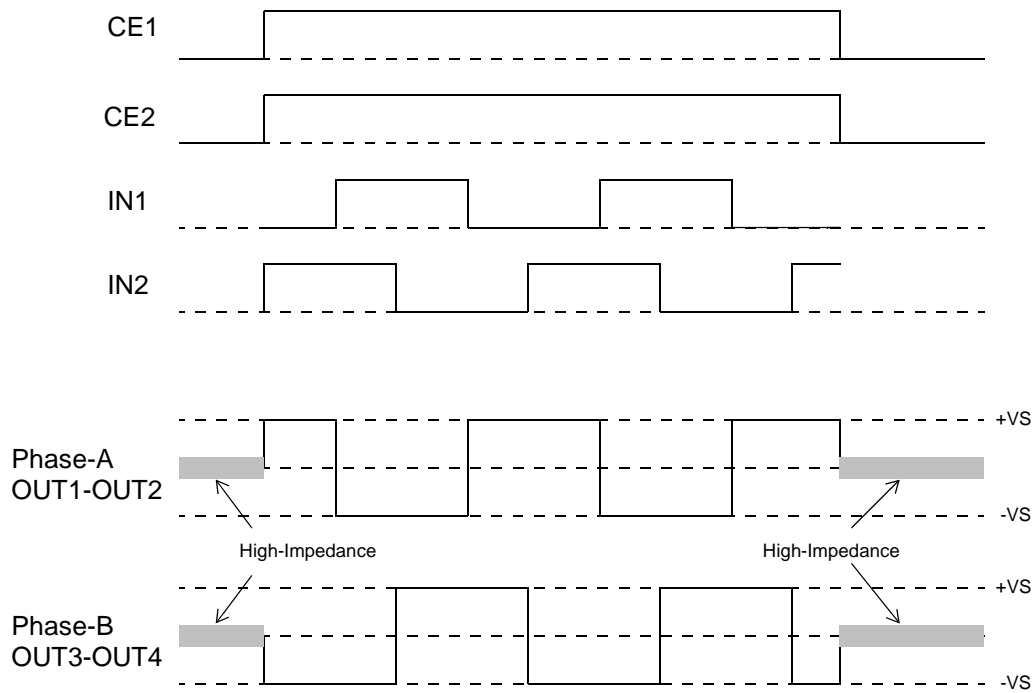

## Electrical Characteristics

( $T_a=25^\circ\text{C}$ ,  $V_{CC}=5\text{V}$ ,  $V_{S1}=3\text{V}$ ,  $V_{S2}=3\text{V}$ , unless otherwise specified)

Parameter	Symbol	Conditions	Min.	Typ.	Max.	Unit
Supply current 1	$I_{CC1}$	$CE1, 2=0\text{V}$	-	0.1	10	$\mu\text{A}$
Supply current 2	$I_{CC2}$	$CE1=3\text{V}$ , $CE2=0\text{V}$ or $CE1=0\text{V}$ , $CE2=3\text{V}$	-	12	18	$\text{mA}$
Saturation voltage 1 (upper + lower total)	$V_{SAT1}$	$CE1=3\text{V}$ , $IN1=3\text{V}$ or $0\text{V}$ , $I_{OUT}=0.2\text{A}$	-	0.2	0.3	$\text{V}$
Saturation voltage 2 (upper + lower total)	$V_{SAT2}$	$CE1=3\text{V}$ , $IN1=3\text{V}$ or $0\text{V}$ , $I_{OUT}=0.4\text{A}$	-	0.4	0.6	$\text{V}$
Input high level voltage	$V_{INH}$	-	1.8	-	$V_{CC}$	$\text{V}$
Input low level voltage	$V_{INL}$	-	-0.3	-	0.7	$\text{V}$
Input current	$I_{IN}$	$IN=3\text{V}$ , Each pin	-	100	200	$\mu\text{A}$
Chip enable current	$I_{CE}$	$CE=3\text{V}$ , Each pin	-	100	200	$\mu\text{A}$
Clamp diode leakage current	$I_{LEAK}$	$V_{CC}=7\text{V}$ , $V_S=7\text{V}$	-	-	30	$\mu\text{A}$
Clamp diode voltage	$V_{CF}$	$I_{OUT}=0.4\text{A}$	-	-	1.7	$\text{V}$

## Typical Performance Characteristics

### $V_{SAT}$ vs. $I_{OUT}$ Characteristics Graph

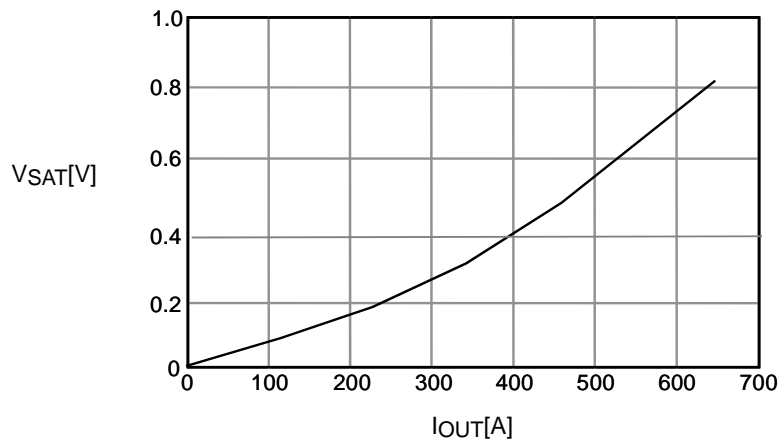

# Test Circuits

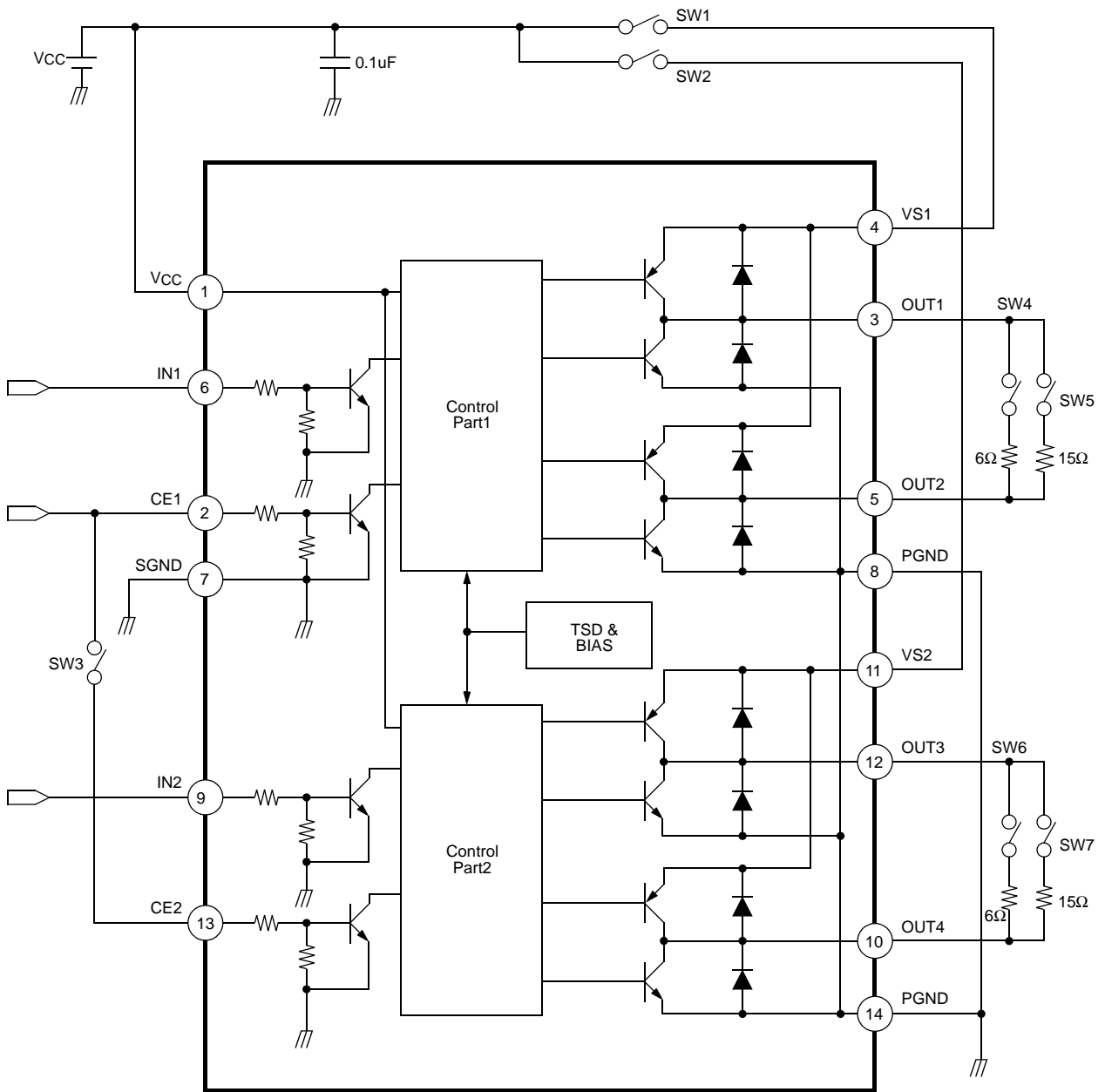

# Typical Application Circuit

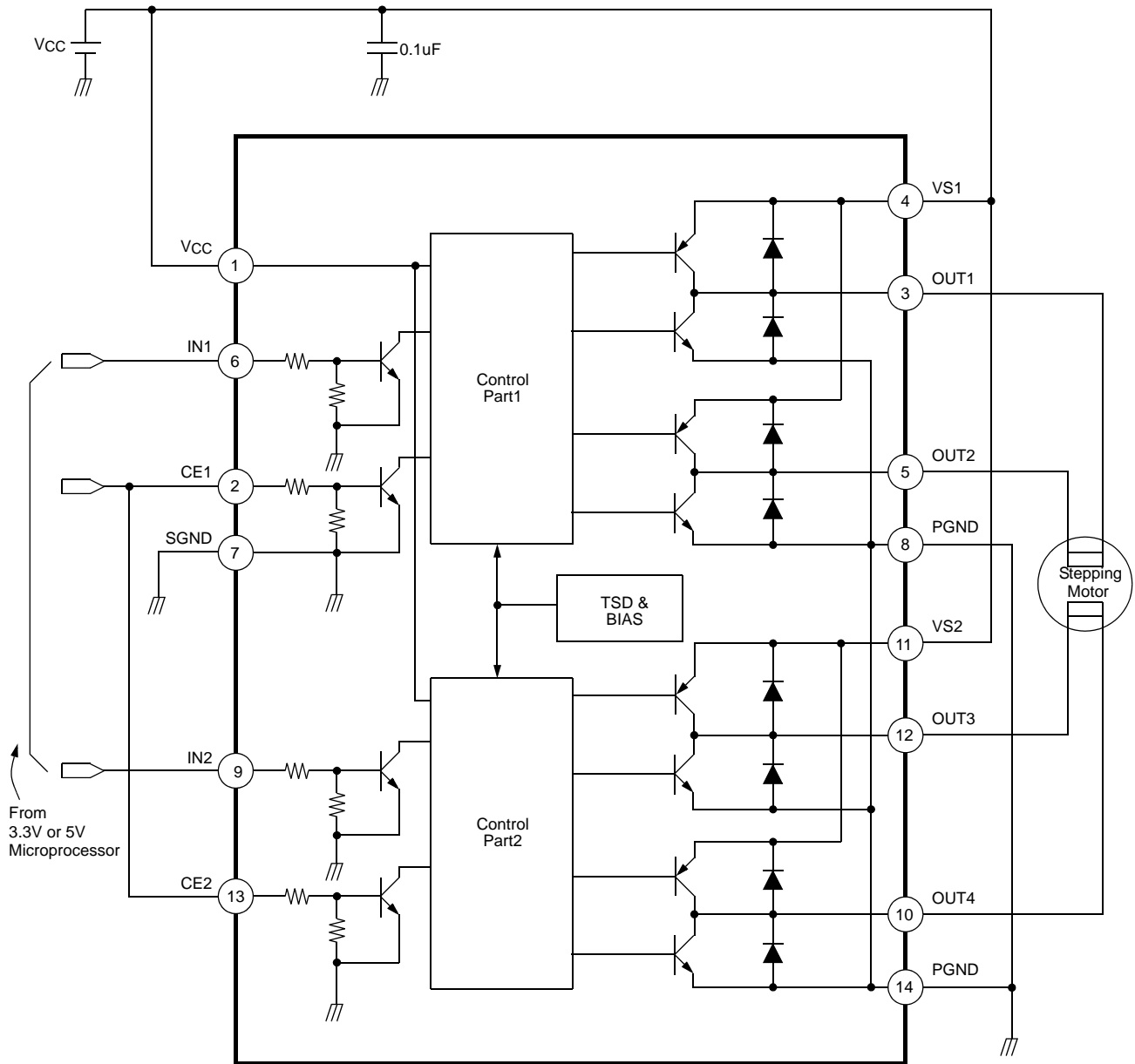

## Application Example - Full Step Bipolar Drive

### Circuit Schematics

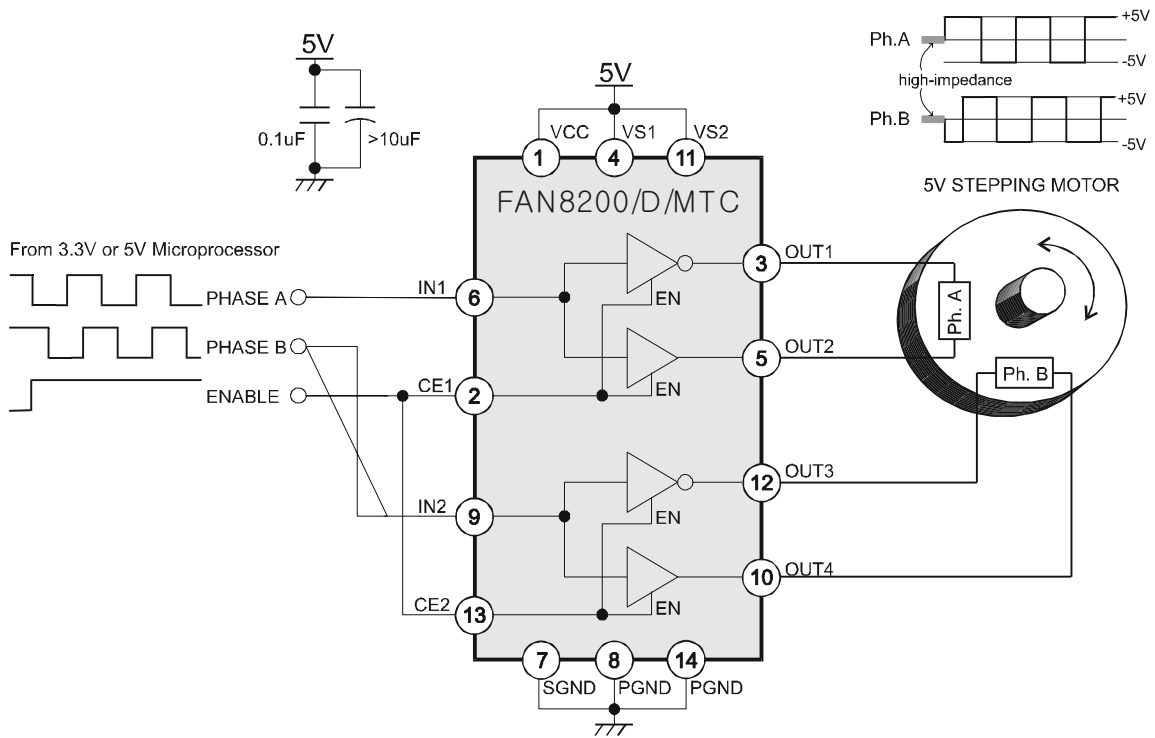

## Application Example - Large Current Buffer

### Circuit Schematics

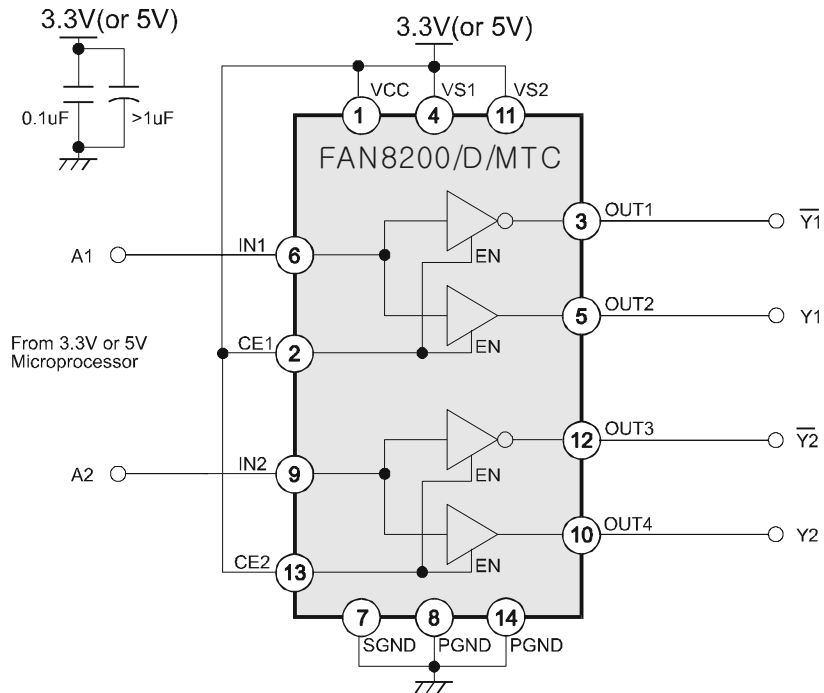

# Application Example - 2-Ch. dc Motor Driver for a Digital Still Camera(DSC)

## Circuit Schematics

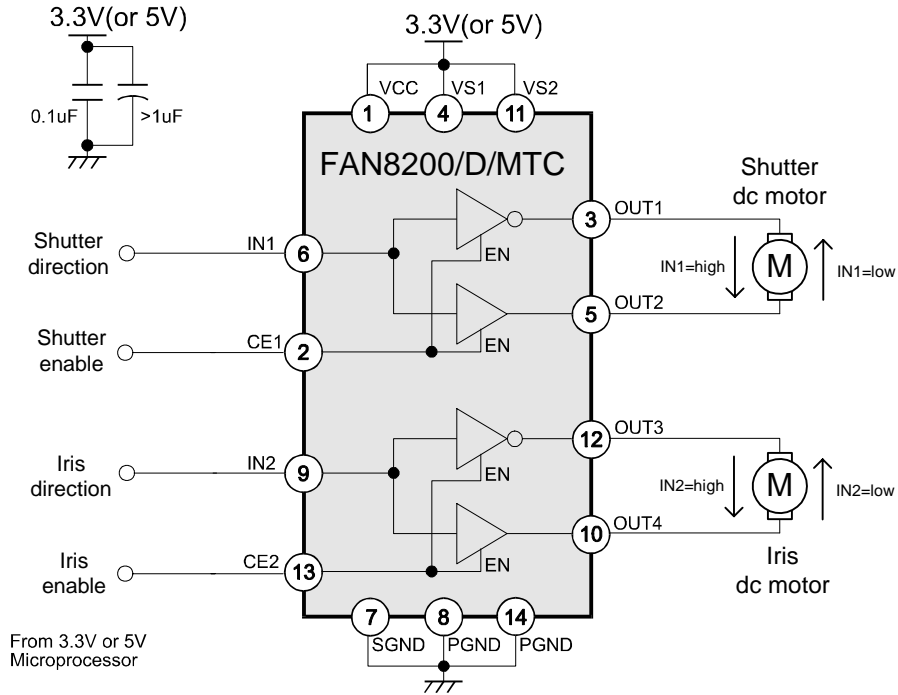

# Mechanical Dimensions (Unit: mm)

## Package Dimensions

### 14-DIP-300

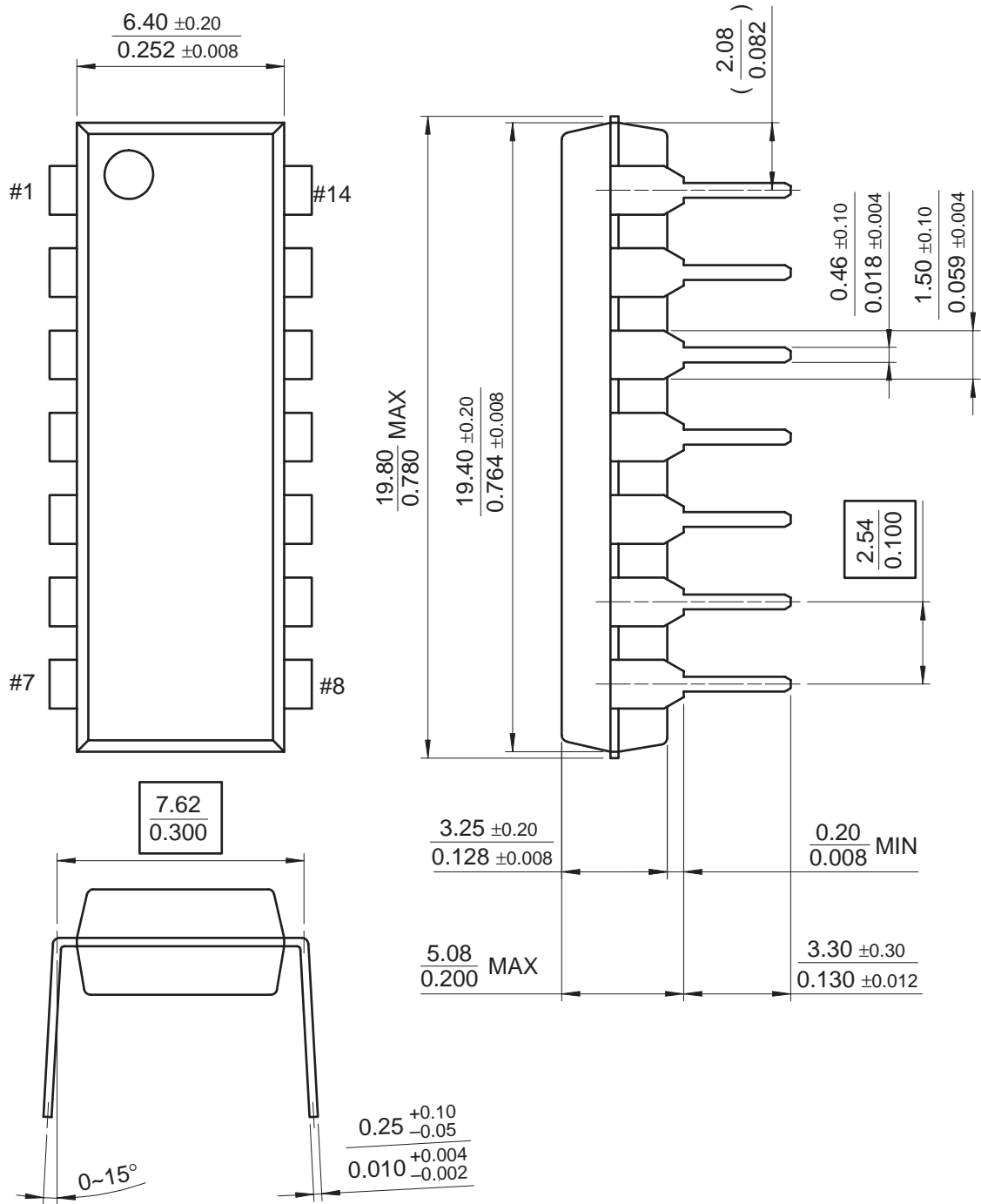

**Mechanical Dimensions (Unit: mm)** (Continued)

**Package Dimensions**

**14-SOP-225**

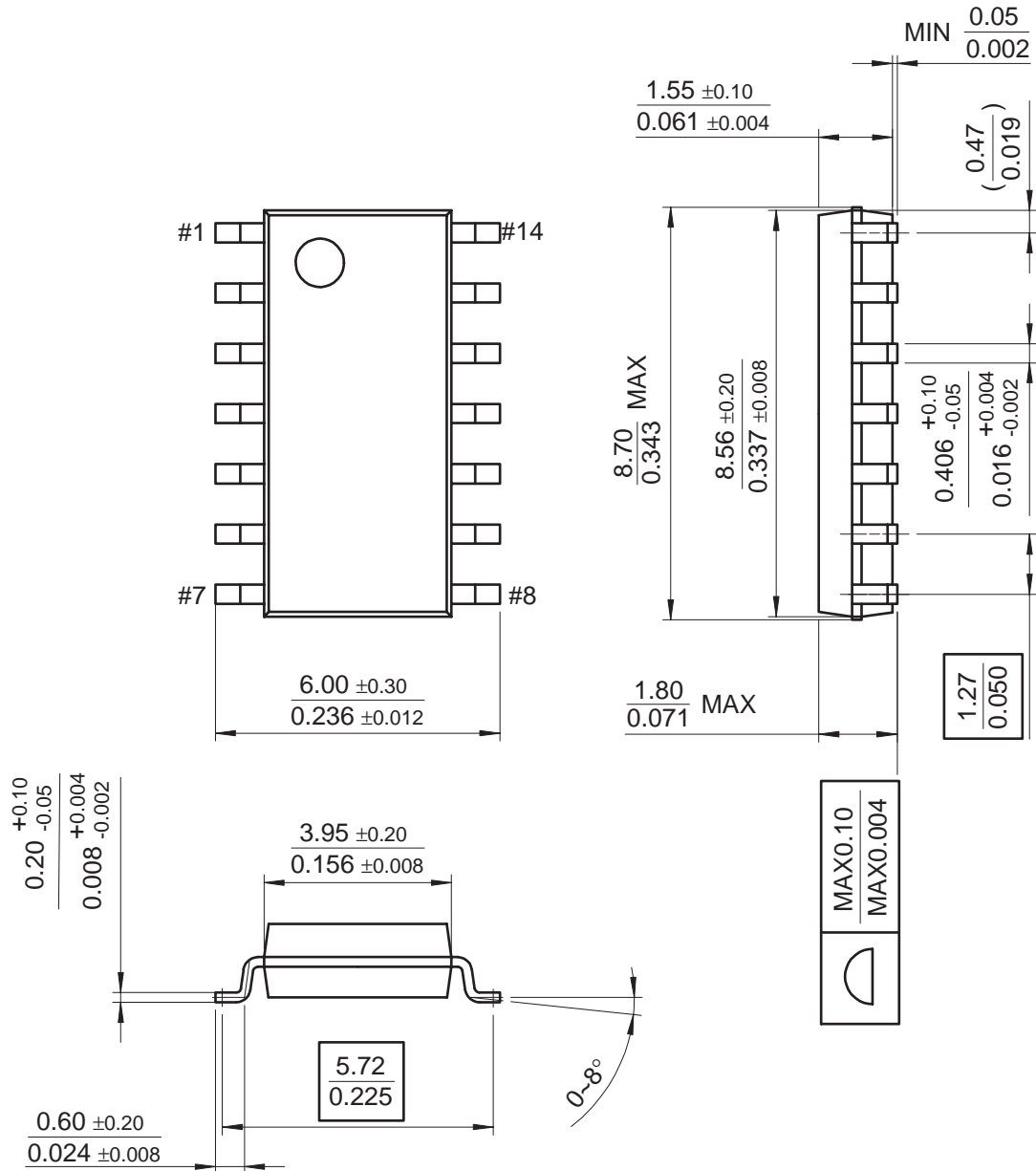



**Mechanical Dimensions (Unit: mm)** (Continued)

**Package dimensions**

**14-MLP**

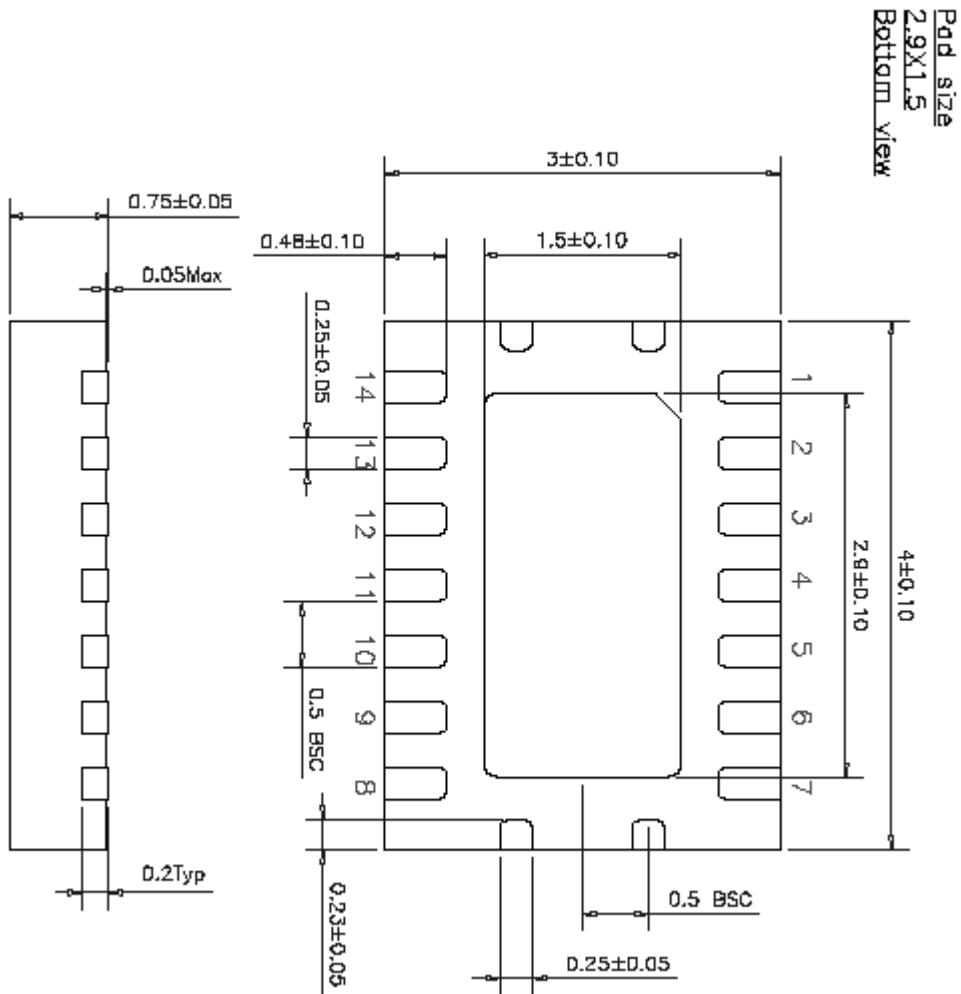

**DISCLAIMER**

FAIRCHILD SEMICONDUCTOR RESERVES THE RIGHT TO MAKE CHANGES WITHOUT FURTHER NOTICE TO ANY PRODUCTS HEREIN TO IMPROVE RELIABILITY, FUNCTION OR DESIGN. FAIRCHILD DOES NOT ASSUME ANY LIABILITY ARISING OUT OF THE APPLICATION OR USE OF ANY PRODUCT OR CIRCUIT DESCRIBED HEREIN; NEITHER DOES IT CONVEY ANY LICENSE UNDER ITS PATENT RIGHTS, NOR THE RIGHTS OF OTHERS.

**LIFE SUPPORT POLICY**

FAIRCHILD'S PRODUCTS ARE NOT AUTHORIZED FOR USE AS CRITICAL COMPONENTS IN LIFE SUPPORT DEVICES OR SYSTEMS WITHOUT THE EXPRESS WRITTEN APPROVAL OF THE PRESIDENT OF FAIRCHILD SEMICONDUCTOR CORPORATION. As used herein:

1. Life support devices or systems are devices or systems which, (a) are intended for surgical implant into the body, or (b) support or sustain life, and (c) whose failure to perform when properly used in accordance with instructions for use provided in the labeling, can be reasonably expected to result in a significant injury of the user.
2. A critical component in any component of a life support device or system whose failure to perform can be reasonably expected to cause the failure of the life support device or system, or to affect its safety or effectiveness.

## Looking for pricing, stock, or lifecycle information?

Click below to explore more details on WIN SOURCE:

-  [View FAN8200MTCX on WIN SOURCE](#)
-  [Fairchild/ON Semiconductor Information](#)

## Optimize Your Supply Chain with WIN SOURCE Solutions

-  Global Sourcing Solution
-  Obsolete Management
-  Cost Control Management
-  Shortage Management
-  Alternative Solution
-  Excess Inventory Management