



FAN7710V, FAN7710VL

Ballast Control IC for Compact Fluorescent Lamps

Features

- Integrated Half-Bridge MOSFET
- Floating Channel FAN7710V for Bootstrap Operation to +440V
- Low Startup and Operating Current: 120µA, 2.6mA
- Under-Voltage Lockout with 1.8V of Hysteresis
- Adjustable Run Frequency and Preheat Time
- Internal Active ZVS Control (FAN7710V Only)
- Internal Protection Function (No Lamp)
- Internal Clamping Zener Diode
- High Accuracy Oscillator
- Soft-Start Functionality

Description

FAN7710V and FAN7710VL, developed using Fairchild's unique high-voltage process and system-in-package (SiP) concept, are ballast control integrated circuits (ICs) for compact fluorescent lamps (CFL). FAN7710V/VL incorporate a preheating / ignition function, controlled by a user-selected external capacitor, to increase lamp life. The FAN7710V detects switch operation from after ignition mode through an internal active Zero-Voltage Switching (ZVS) control circuit (FAN7710VL does not). This control scheme enables the FAN7710V to detect an open-lamp condition without the expense of external circuitry and prevents stress on MOSFETs. The high-side driver built into the FAN7710V/VL has a common-mode noise cancellation circuit that provides robust operation against high-dv/dt noise intrusion.

Applications

- Compact Fluorescent Lamp Ballast

8-DIP



Ordering Information

Part Number	Operating Temperature	 Eco Status	Package	Packing Method
FAN7710VN	-40 to +125°C	RoHS	8-Lead Dual Inline Package (DIP)	Tube
FAN7710VLN				

 For Fairchild's definition of Eco Status, please visit: http://www.fairchildsemi.com/company/green/rohs_green.html.

Typical Applications Diagrams

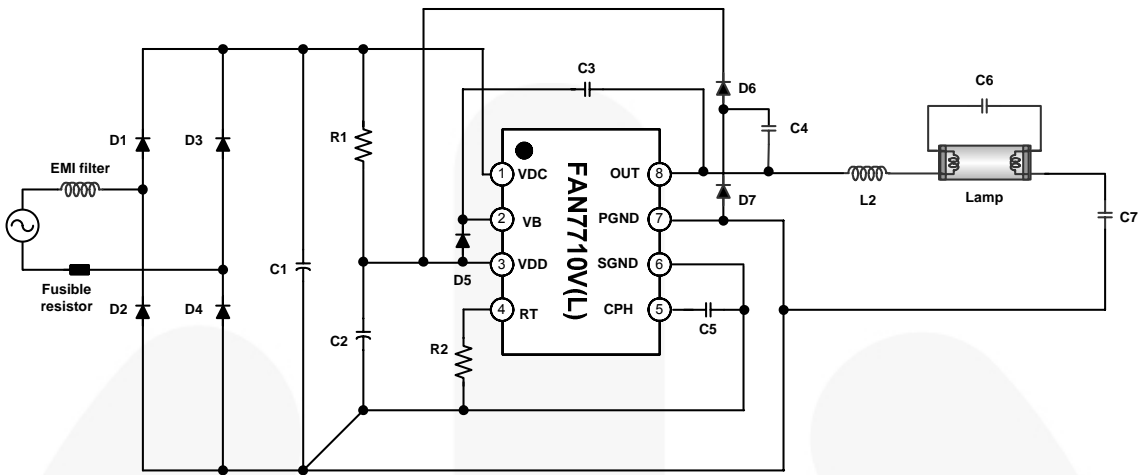

Figure 1. Typical Application Circuit for Compact Fluorescent Lamp

Internal Block Diagram

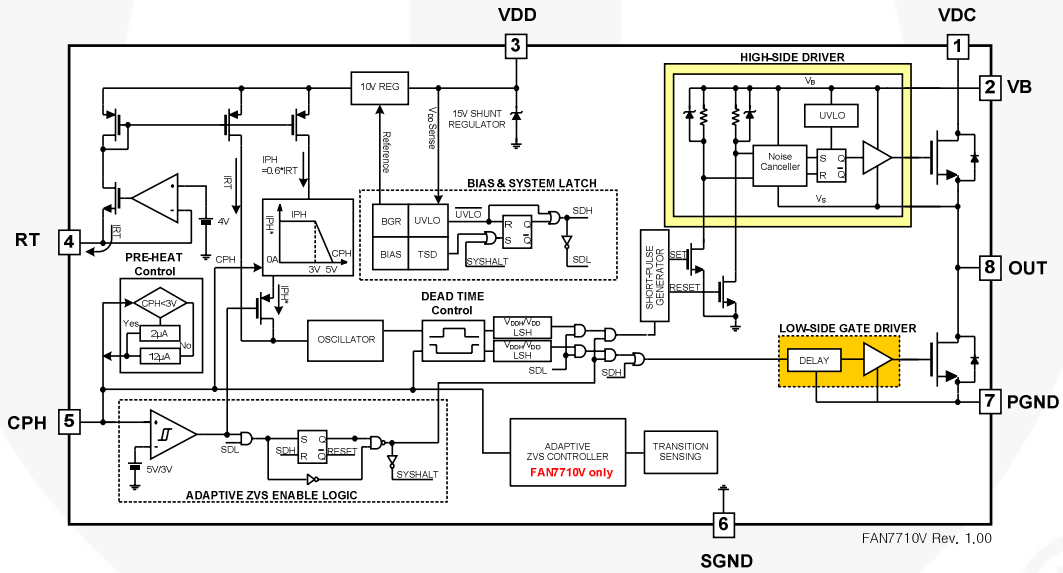

Figure 2. Functional Block Diagram

Pin Configuration

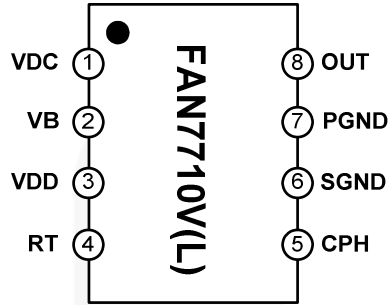

Figure 3. Pin Configuration (Top View)

Pin Definitions

Pin #	Name	Description
1	VDC	High-Voltage Supply
2	VB	High-Side Floating Supply
3	VDD	Supply Voltage
4	RT	Oscillator Frequency Set Resistor
5	CPH	Preheating Time Set Capacitor
6	SGND	Signal Ground
7	PGND	Power Ground
8	OUT	High-Side Floating Supply Return

Absolute Maximum Ratings

Stresses exceeding the absolute maximum ratings may damage the device. The device may not function or be operable above the recommended operating conditions and stressing the parts to these levels is not recommended. In addition, extended exposure to stresses above the recommended operating conditions may affect device reliability. The absolute maximum ratings are stress ratings only. $T_A=25^{\circ}\text{C}$ unless otherwise specified.

Symbol	Parameter	Min.	Typ.	Max.	Unit
V_B	High-Side Floating Supply Voltage	-0.3		465.0	V
V_{OUT}	High-Side Floating Supply Return	-0.3		440.0	V
V_{IN}	RT, CPH Pins Input Voltage	-0.3		8.0	V
I_{CL}	Clamping Current Level ⁽¹⁾			25	mA
dV_{OUT}/dt	Allowable Offset Voltage Slew Rate		50		V/ns
T_A	Operating Temperature Range	-40		+125	$^{\circ}\text{C}$
T_{STG}	Storage Temperature Range	-65		+150	$^{\circ}\text{C}$
P_D	Power Dissipation		2.1		W
Θ_{JA}	Thermal Resistance, Junction-to-Air		70		$^{\circ}\text{C}/\text{W}$

Note:

- Do not supply a low-impedance voltage source to the internal clamping Zener diode between the GND and the VDD pin of this device.

Electrical Characteristics

V_{BIAS} (V_{DD} , $V_B - V_{OUT}$)=14.0V and $T_A=25^\circ\text{C}$, unless otherwise specified.

Symbol	Parameter	Conditions	Min.	Typ.	Max.	Unit
High-Voltage Supply Section						
V_{DC}	High-Voltage Supply Voltage		440			V
Low-Side Supply Section (V_{DD})						
$V_{DDTH(ST+)}$	V_{DD} UVLO Positive-Going Threshold	V_{DD} Increasing	12.4	13.4	14.4	V
$V_{DDTH(ST-)}$	V_{DD} UVLO Negative-Going Threshold	V_{DD} Decreasing	10.8	11.6	12.4	
$V_{DDHY(ST)}$	V_{DD} -Side UVLO Hysteresis			1.8		
V_{CL}	Supply Camping Voltage	$I_{DD}=10\text{mA}$	14.8	15.2		
I_{ST}	Startup Supply Current	$V_{DD}=10\text{V}$		120		μA
I_{DD}	Dynamic Operating Supply Current	50kHz, $C_L=1\text{nF}$		2.6		mA
High-Side Supply Characteristics ($V_B - V_{OUT}$)						
$V_{HSTH(ST+)}$	High-Side UVLO Positive-Going Threshold	$V_B - V_{OUT}$ Increasing	8.5	9.2	10.0	V
$V_{HSTH(ST-)}$	High-Side UVLO Negative-Going Threshold	$V_B - V_{OUT}$ Decreasing	7.9	8.6	9.5	
$V_{HSHY(ST)}$	High-Side UVLO Hysteresis			0.6		
I_{HST}	High-Side Quiescent Supply Current	$V_B - V_{OUT}=14\text{V}$		50		μA
I_{HD}	High-Side Dynamic Operating Supply Current	50kHz, $C_L=1\text{nF}$		250		
Oscillator Section						
V_{MPH}	CPH Pin Preheating Voltage Range		2.5	3.0	3.5	V
I_{PH}	CPH Pin Charging Current During Preheating	$V_{CPH}=1\text{V}$	1.25	2.00	2.85	μA
I_{IG}	CPH Pin Charging Current During Ignition	$V_{CPH}=4\text{V}$	8	12	16	
V_{MO}	CPH Pin Voltage Level at Running Mode			7.0		V
f_{PRE}	Preheating Frequency	$R_T=80\text{k}\Omega$, $V_{CPH}=2\text{V}$	72	85	98	kHz
f_{OSC}	Running Frequency	$R_T=80\text{k}\Omega$	48.7	53.0	57.3	kHz
DT_{MAX}	Maximum Dead Time	$V_{CPH}=1\text{V}$, $V_{OUT}=SGND$ During Preheat Mode		3.1		μs
DT_{MIN}	Minimum Dead Time	$V_{CPH}=6\text{V}$, $V_{OUT}=SGND$ During Run Mode		1.0		μs
Protection Section						
V_{CPHSD}	Shutdown Voltage	$V_{RT}=0$ After Run Mode	2.6			V
I_{SD}	Shutdown Current				250	450
TSD	Thermal Shutdown ⁽²⁾			+165		$^\circ\text{C}$
Internal MOSFET Section						
$I_{LK MOS}$	Internal MOSFET Leakage Current	$V_{DS}=400\text{V}$			50	μA
R_{ON}	Static Drain-Source On-Resistance	$V_{GS}=10\text{V}$, $I_D=190\text{mA}$		4.6	6.0	Ω
I_S	Maximum Continuous Drain-Source Diode Forward Current				0.38	A
I_{SM}	Maximum Pulsed Continuous Drain-Source Diode Forward Current				3.04	
V_{SD}	Drain-Source Diode Forward Voltage	$V_{GS}=0\text{V}$, $I_S=0.38\text{A}$			1.4	V

Note:

- These parameters, although guaranteed, is not 100% tested in production.

Typical Performance Characteristics

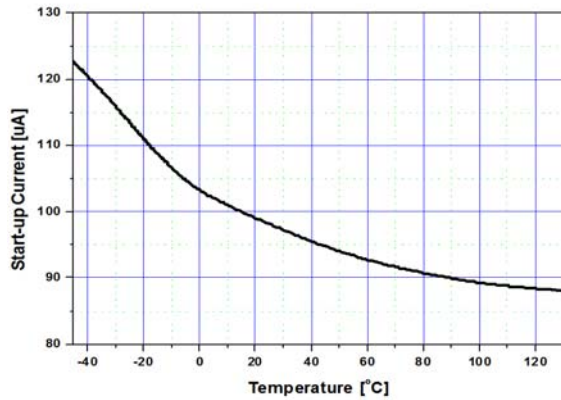

Figure 4. Startup Current vs. Temperature

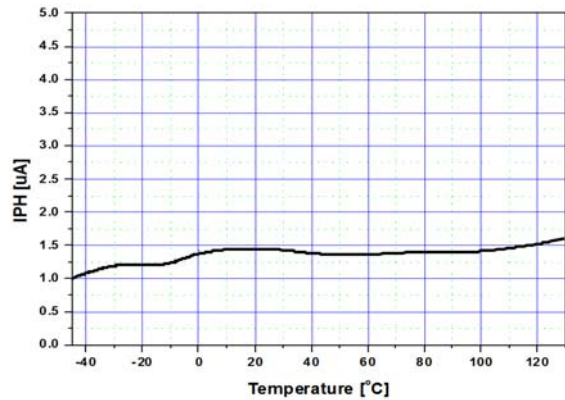

Figure 5. Preheating Current vs. Temperature

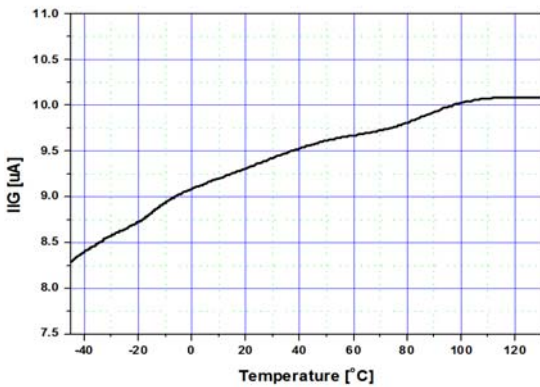

Figure 6. Ignition Current vs. Temperature

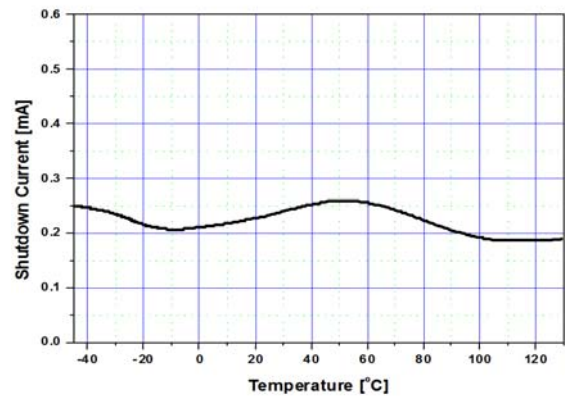

Figure 7. Operating Current vs. Temperature

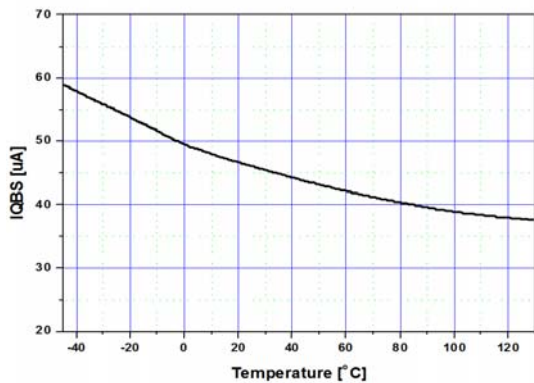

Figure 8. High-Side Quiescent Current vs. Temperature

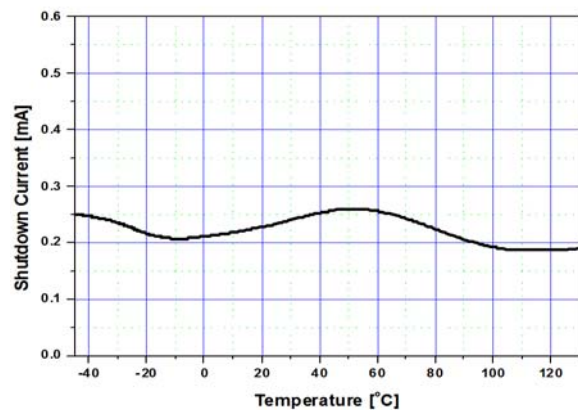

Figure 9. Shutdown Current vs. Temperature

Typical Performance Characteristics (Continued)

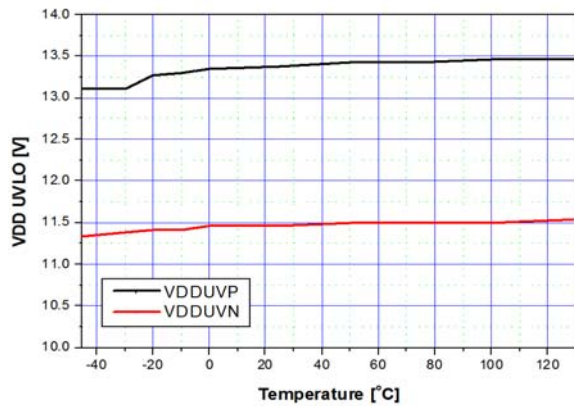

Figure 10. V_{DD} UVLO vs. Temperature

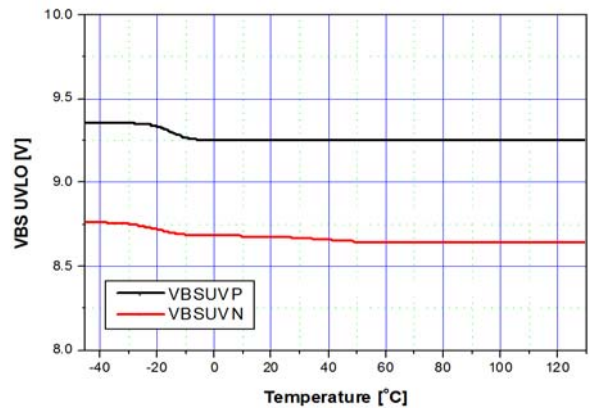

Figure 11. V_{BS} UVLO vs. Temperature

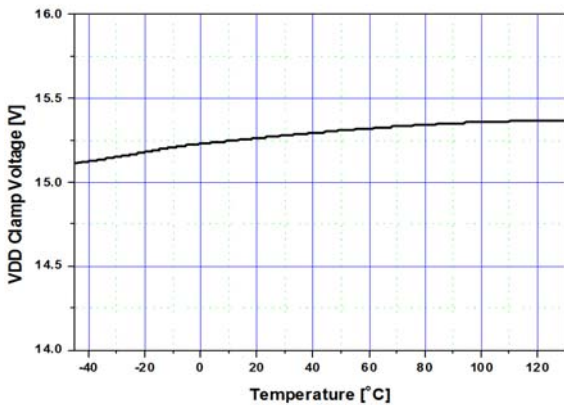

Figure 12. V_{DD} Clamp Voltage vs. Temperature

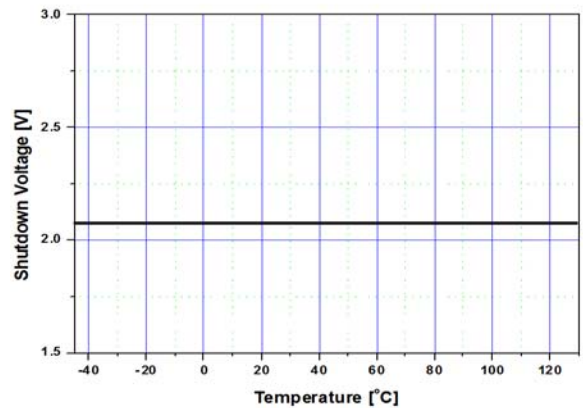

Figure 13. Shutdown Voltage vs. Temperature

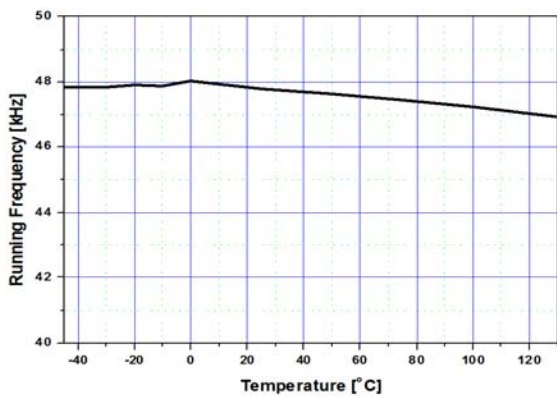

Figure 14. Running Frequency vs. Temperature

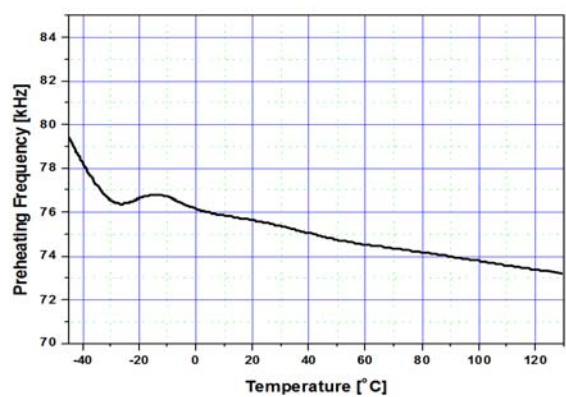

Figure 15. Preheating Frequency vs. Temperature

Typical Performance Characteristics (Continued)

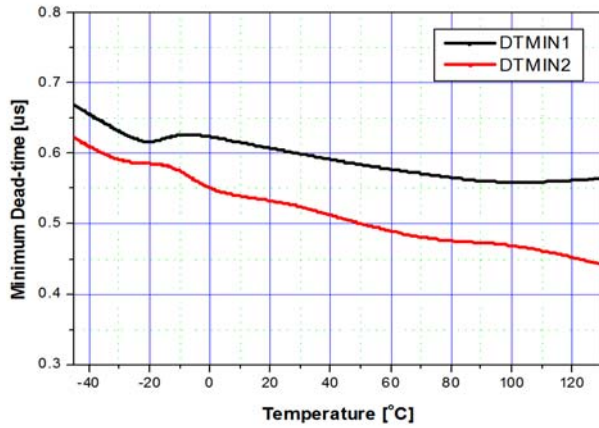

Figure 16. Minimum Dead Time vs. Temperature

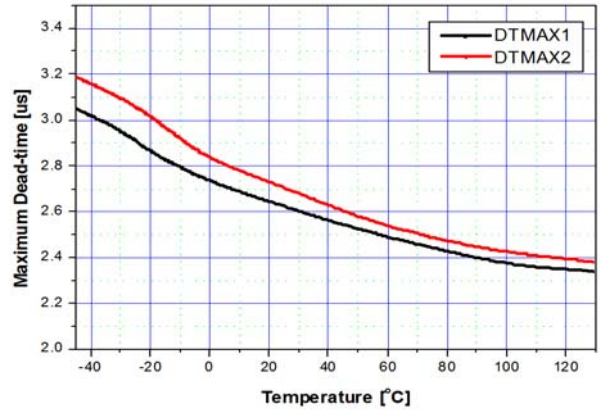

Figure 17. Maximum Dead Time vs. Temperature

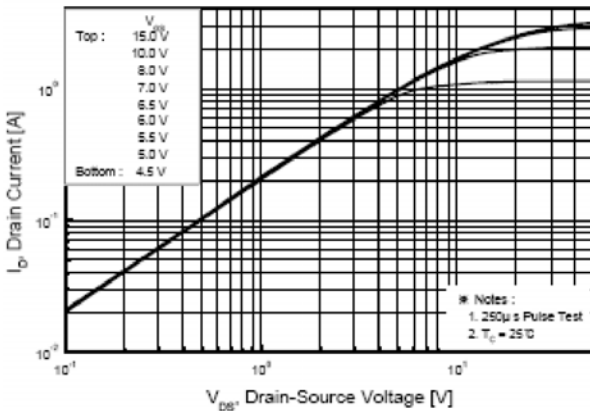

Figure 18. On-Region Characteristics

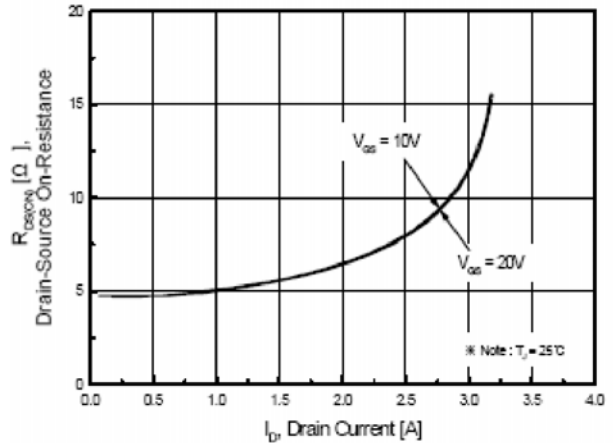

Figure 19. On-Resistance Variation vs. Drain Current and Gate Voltage

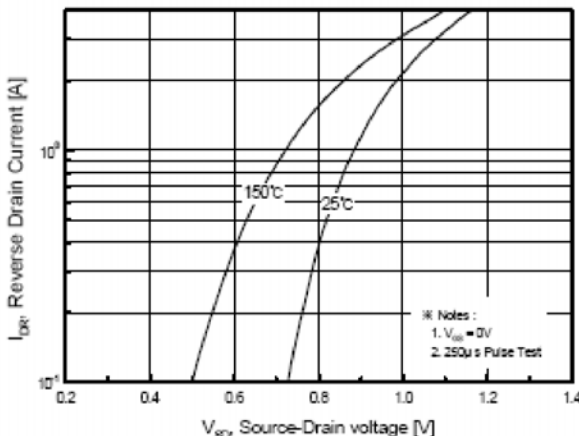

Figure 20. Body Diode Forward Voltage Variation vs. Source Current and Temperature

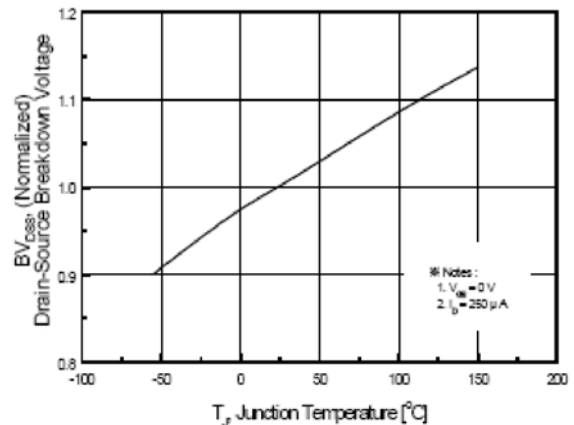

Figure 21. Breakdown Voltage Variation vs. Temperature

Typical Performance Characteristics (Continued)

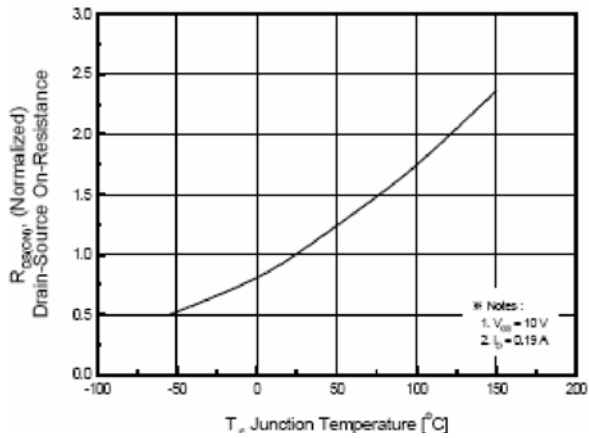

Figure 22. On-Resistance Variation vs. Temperature

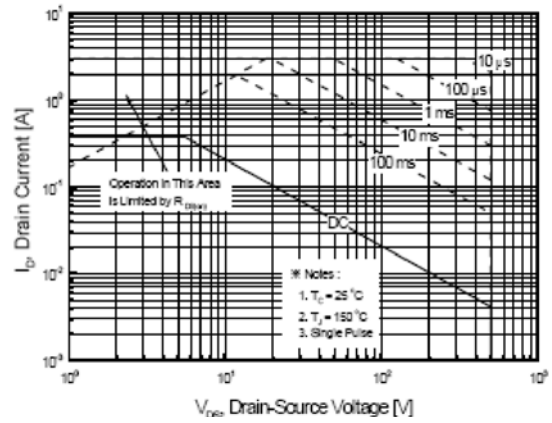

Figure 23. Maximum Safe Operating Area

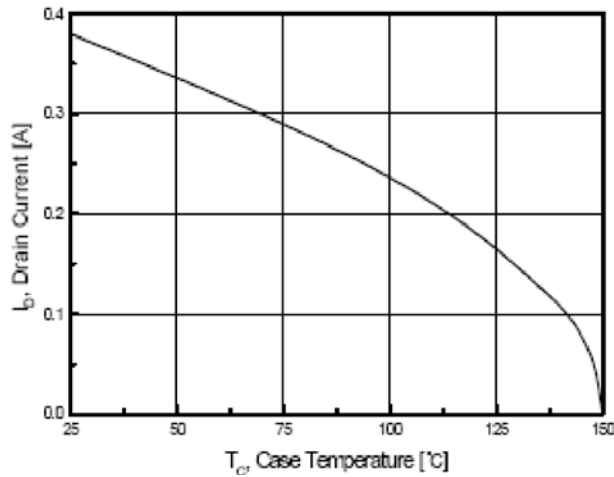

Figure 24. Maximum Drain-Current vs. Case Temperature



Typical Application Information

1. Under-Voltage Lockout (UVLO) Function

The FAN7710V/VL has UVLO circuits for both high-side and low-side circuits. When V_{DD} reaches $V_{DDTH(ST+)}$, UVLO is released and the FAN7710V/VL operates normally. At UVLO condition, FAN7710V/VL consumes little current, noted as I_{ST} . Once UVLO is released, FAN7710V/VL operates normally until V_{DD} goes below $V_{DDTH(ST-)}$, the UVLO hysteresis. At UVLO condition, all latches that determine the status of the IC are reset. When the IC is in the shutdown mode, the IC can restart by lowering V_{DD} voltage below $V_{DDTH(ST-)}$.

FAN7710V/VL has a high-side gate driver circuit. The supply for the high-side driver is applied between V_B and V_{OUT} . To protect from malfunction of the driver at low supply voltage between V_B and V_{OUT} , there is an additional UVLO circuit between the supply rails. If $V_B - V_{OUT}$ is under $V_{HSTH(ST+)}$, the driver holds LOW state to turn off the high-side switch, as shown in Figure 25. As long as $V_B - V_{OUT}$ is higher than $V_{HSTH(ST-)}$ after $V_B - V_{OUT}$ exceeds $V_{HSTH(ST+)}$, operation of the driver continues.

2. Oscillator

The ballast circuit for a fluorescent lamp is based on the LCC resonant tank and a half-bridge inverter circuit, as shown in Figure 25. To accomplish Zero-Voltage Switching (ZVS) of the half-bridge inverter circuit, the LCC is driven at a higher frequency than its resonant frequency, which is determined by L , C_S , C_P , and R_L ; where R_L is the equivalent lamp's impedance.

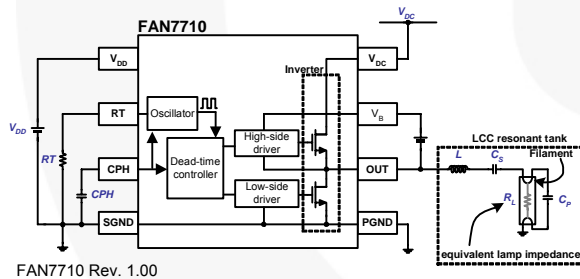

Figure 25. Typical Connection Method

The transfer function of LCC resonant tank is heavily dependent on the lamp impedance, R_L , as illustrated in Figure 26. The oscillator in FAN7710V generates effective driving frequencies to assist lamp ignition and improve lamp life longevity. Accordingly, the oscillation frequency is changed in following sequence:

Preheating Frequency → *Ignition Frequency* → *Normal Running Frequency*

Before the lamp is ignited, the lamp impedance is very high. Once the lamp is turned on, the lamp impedance significantly decreases. Since the resonant peak is very high due to the high-resistance of the lamp at the instant of turning on the lamp, the lamp must be driven at higher frequency than the resonant frequency, shown as (A) in Figure 26. In this mode, the current supplied by the inverter mainly flows through C_P . C_P connects both

filaments and makes the current path to ground. As a result, the current warms up the filament for easy ignition. The amount of the current can be adjusted by controlling the oscillation frequency or changing the capacitance of C_P . The driving frequency, f_{PRE} , is called preheating frequency and is derived by:

$$f_{PRE} = 1.6 \times f_{OSC} \quad (1)$$

After the warm-up, the FAN7710V/VL decreases the frequency, shown as (B) of Figure 26. This action increases the voltage of the lamp and helps the fluorescent lamp ignite. The ignition frequency is described as a function of C_{PH} voltage, as follows:

$$f_{IG} = [0.3 \times (5 - V_{CPH}) + 1] \times f_{OSC} \quad (2)$$

where V_{CPH} is the voltage of C_{PH} capacitor.

Equation 2 is valid only when V_{CPH} is between 3V and 5V before entering running mode. Once V_{CPH} reaches 5V, the internal latch records the exit from ignition mode. Unless V_{DD} is below $V_{DDTH(ST-)}$, the preheating and ignition modes appear only during lamp-start transition.

Finally, the lamp is driven at a fixed frequency by an external resistor, R_T , shown as (C) in Figure 26. If V_{DD} is higher than $V_{DDTH(ST+)}$ and UVLO is released, the voltage of the R_T pin is regulated to 4V. This voltage adjusts the oscillator's control current according to the resistance of R_T . Because this current and an internal capacitor set the oscillation frequency, the FAN7710V/VL does not need any external capacitors.

The proposed oscillation characteristic is given by:

$$f_{OSC} = \frac{4 \times 10^9}{RT} \quad (3)$$

Even in the active ZVS mode, shown as (D) in Figure 26, the oscillation frequency is not changed. The dead time is varied according to the resonant tank characteristic.

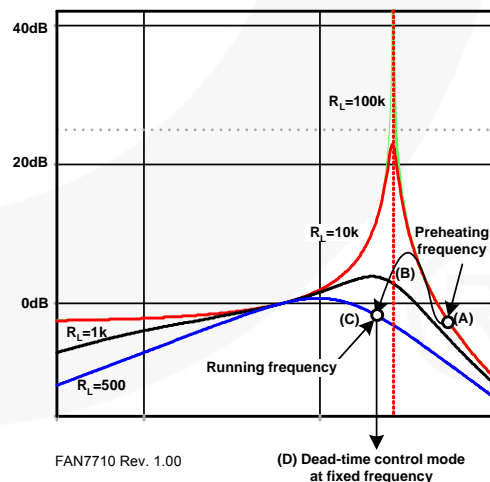
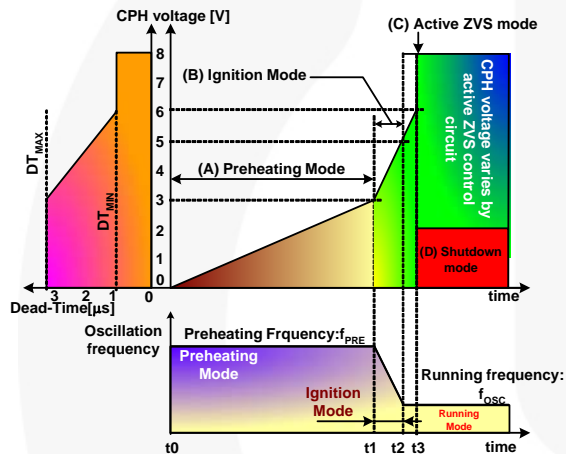

Figure 26. LCC Transfer Function in Terms of Lamp Impedance

3. Operation Modes

FAN7710V/VL has four operation modes: (A) preheating mode, (B) ignition mode, (C) active ZVS mode (FAN7710V only), and (D) shutdown mode; all depicted in Figure 27. The modes are automatically selected by the voltage of CPH capacitor shown in Figure 27. In modes (A) and (B), the CPH acts as a timer to determine the preheating and ignition times. After preheating and ignition modes, the role of the CPH is changed to stabilize the active ZVS control circuit. In this mode, the dead time of the inverter is selected by the voltage of CPH. Only when in active ZVS mode is it possible to shut off the whole system using the CPH pin. Pulling the CPH pin below 2V in active ZVS mode causes the FAN7710V series to enter shutdown mode. In shutdown mode, all active operation is stopped except UVLO and some bias circuitry. The shutdown mode is triggered by the external CPH control or the active ZVS circuit. The active ZVS circuit automatically detects lamp removal (open-lamp condition) and decreases CPH voltage below 2V to protect the inverter switches from damage.



FAN7710 Rev. 1.00

Figure 27. Operation Modes

3.1 Preheating Mode (t_0 ~ t_1)

When V_{DD} exceeds $V_{DDTH(ST+)}$, the FAN7710V series starts operation. At this time, an internal current source (I_{PH}) charges CPH. CPH voltage increases from 0V to 3V in preheating mode. Accordingly, the oscillation frequency follows Equation 4. In this mode, the lamp is not ignited, but warmed up for easy ignition. The preheating time depends on the size of CPH:

$$t_{preheat} = \frac{3 \times CPH}{I_{PH}} [\text{seconds}] \quad (4)$$

According to the preheating process, the voltage across the lamp to ignite is reduced and the lifetime of the lamp is increased. In this mode, the dead time is fixed at its maximum value.

3.2 Ignition Mode (t_1 ~ t_2)

When the CPH voltage exceeds 3V, the internal current source charging CPH is increased about six times larger than I_{PH} , noted as I_{IG} , causing rapid increase in CPH voltage. The internal oscillator decreases the oscillation frequency from f_{PRE} to f_{OSC} as CPH voltage increases. As depicted in Figure 27, lowering the frequency increases the voltage across the lamp. Finally, the lamp ignites. Ignition mode is when CPH voltage is between 3V and 5V. Once CPH voltage reaches 5V, the FAN7710V/VL does not return to ignition mode, even if the CPH voltage is in that range, until the FAN7710V/VL restarts from below $V_{DDTH(ST-)}$. Since the ignition mode continues when CPH is from 3V to 5V, the ignition time is given by:

$$t_{ignition} = \frac{2 \times CPH}{I_{IG}} [\text{seconds}] \quad (5)$$

In this mode, dead time varies according to the CPH voltage.

3.3 Running Mode and Active Zero-Voltage Switching (AZVS) Mode (t_2 ~)

When CPH voltage exceeds 5V, the operating frequency is fixed to f_{OSC} by R_T . However, active ZVS operation is not activated until CPH reaches ~6V. Only the FAN7710V prepares for active ZVS operation from the instant CPH exceeds 5V during t_2 to t_3 . When CPH becomes higher than ~6V at t_3 , the active ZVS operation is activated. To determine the switching condition, FAN7710V detects the transition time of the output (VS pin) of the inverter by using the VB pin. From the output-transition information, FAN7710V controls the dead time to meet the ZVS condition. If ZVS is satisfied, the FAN7710V slightly increases the CPH voltage to reduce the dead time and to find optimal dead time, which increases the efficiency and decreases the thermal dissipation and EMI of the inverter switches. If ZVS fails, the FAN7710V decreases CPH voltage to increase the dead time. CPH voltage is adjusted to meet optimal ZVS operation. During the active ZVS mode, the amount of the charging / discharging current is the same as I_{PH} . All of the functions between FAN7710V and FAN7710VL are similar except the AZVS (Active Zero Voltage Switching) function. Figure 28 depicts normal operation waveforms.

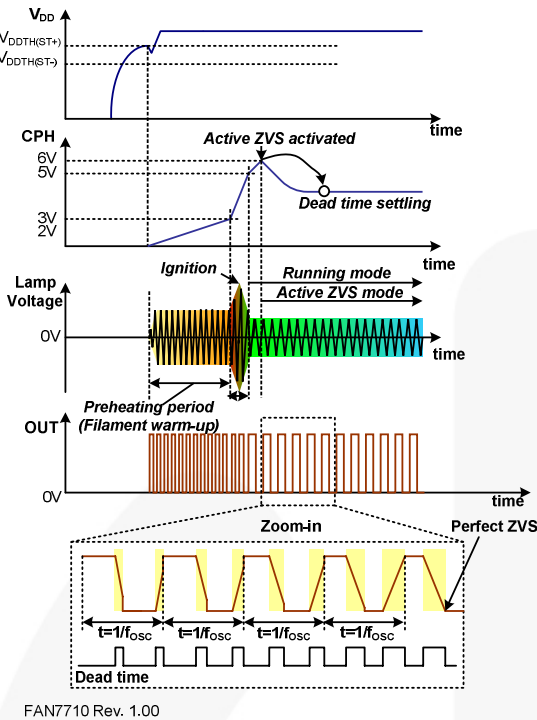

FAN7710 Rev. 1.00
Figure 28. LCC Transfer Function in Terms of Lamp Impedance

3.4 Shutdown Mode

If the voltage of capacitor CPH is decreased below ~2.1V by an external application circuit or internal protection circuit, the IC enters shutdown mode. Once the IC enters shutdown mode, this status continues until an internal latch is reset by decreasing V_{DD} below V_{DDTH}(ST-). Figure 29 shows an example of external shutdown control circuit.

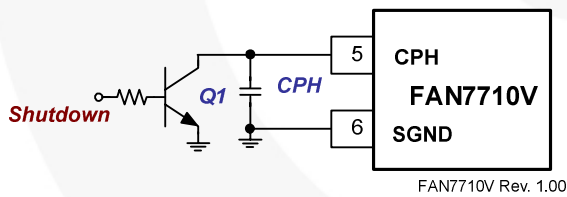

FAN7710V Rev. 1.00
Figure 29. External Shutdown Circuit

The amount of the CPH charging current is the same as I_{PH}, making it possible to shut off the IC using a small signal transistor. Only the FAN7710V provides active ZVS operation by controlling the dead time according to the voltage of CPH. If ZVS fails, even at the maximum dead time, FAN7710V stops driving the inverter.

The FAN7710V thermal shutdown circuit senses the junction temperature of the IC. If the temperature exceeds ~160°C, the thermal shutdown circuit stops operation of the FAN7710V.

The current usages of shutdown mode and under-voltage lockout status are different. In shutdown mode, some circuit blocks, such as bias circuits, are kept alive. Therefore, the current consumption is slightly higher than during under-voltage lockout.

4. Automatic Open-Lamp Detection (FAN7710V Only)

The FAN7710V can automatically detect an open-lamp condition. When the lamp is opened, the resonant tank fails to make a closed-loop to the ground, as shown in Figure 30. The supplied current from the OUT pin is used to charge and discharge the charge pump capacitor, C_P. Since the open-lamp condition means resonant tank absence, it is impossible to meet ZVS condition. In this condition, the power dissipation of the FAN7710V, due to capacitive load drive, is estimated as:

$$P_{dissipation} = \frac{1}{2} \times C_P \times V_{DC}^2 \times f \quad [W] \quad (6)$$

where *f* is driving frequency and V_{DC} is DC-link voltage.

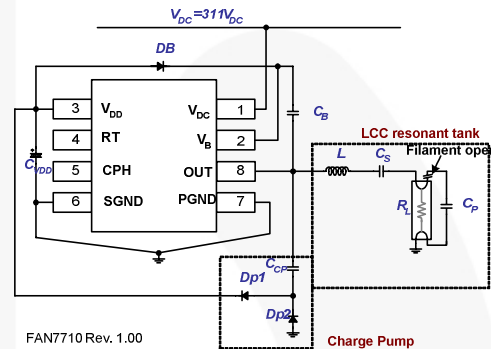

FAN7710 Rev. 1.00
Figure 30. Current Flow When the Lamp is Open

Assuming that C_P, V_{DC}, and *f* are 1nF, 311V, and 50kHz, respectively; the power dissipation reaches about 2.4W and the temperature of is increased rapidly. If no protection is provided, the IC can be damaged by the thermal attack. Note that a hard-switching condition during the capacitive-load drive causes EMI.

Figure 31 illustrates the waveforms during the open-lamp condition. In this condition, the charging and discharging current of C_P is directly determined by FAN7710V and considered hard-switching condition. The FAN7710V tries to meet ZVS condition by decreasing CPH voltage to increase dead time. If ZVS fails and CPH goes below 2V, even though the dead time reaches its maximum value, FAN7710V shuts off the IC to protect against damage. To restart FAN7710V, V_{DD} must be below V_{DDTH}(ST-) to reset an internal latch circuit, which remembers the status of the IC.

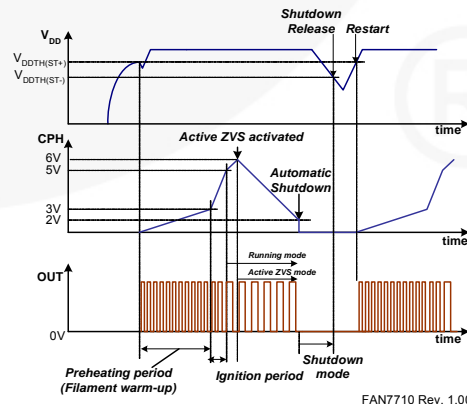

FAN7710 Rev. 1.00
Figure 31. CPH Voltage Variation During Open-Lamp

5. Power Supply

When V_{DD} is lower than $V_{DDTH(ST+)}$, it consumes very little current, I_{ST} , making it possible to supply current to the V_{DD} pin using a resistor with high resistance (R_{start} in Figure 32). Once UVLO is released, the current consumption is increased and whole circuit is operated, which requires additional power supply for stable operation. The supply must deliver at least several mA. A charge pump circuit is a cost-effective method to create an additional power supply and allows C_P to be used to reduce the EMI.

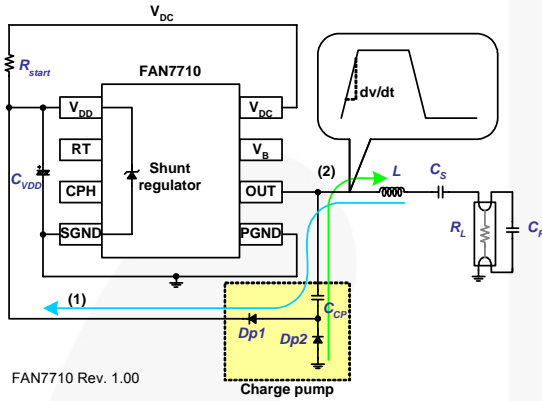

Figure 32. Local Power Supply for V_{DD} Using a Charge-Pump Circuit

As presented in Figure 32; when OUT is HIGH, the inductor current and C_{CP} create an output transition with the slope of dv/dt . The rising edge of OUT charges C_{CP} . At that time, the current that flows through C_{CP} is:

$$I \cong C_{CP} \times \frac{dv}{dt} \tag{7}$$

This current flows along path 1 in Figure 32. It charges C_{VDD} , which is a bypass capacitor to reduce the noise on the supply rail. If C_{VDD} is charged over the threshold voltage of the internal shunt regulator, the shunt regulator turns on and regulates V_{DD} with the trigger voltage.

When OUT is changing from HIGH to LOW state, C_{CP} is discharged through Dp2, shown as path 2 in Figure 32. These charging/discharging operations are continued until FAN7710V/VL is halted by shutdown operation. The charging current, I , must be large enough to supply the operating current of FAN7710V series.

The supply for the high-side gate driver is provided by the boot-strap technique, as illustrated in Figure 33. When the low-side MOSFET connected between OUT and PGND pins is turned on, the charging current for V_B flows through D_B . Every low OUT gives the chance to charge the C_B . Therefore, C_B voltage builds up only when FAN7710V/VL operates normally.

When OUT goes HIGH, the diode D_B is reverse-biased and C_B supplies the current to the high-side driver. At this time, since C_B discharges, $V_B - V_{OUT}$ voltage decreases. If $V_B - V_{OUT}$ goes below $V_{HSTH(ST-)}$, the high-side driver cannot operate due to the high-side UVLO protection circuit. C_B must be chosen to be large enough not to fall into UVLO range, due to the discharge during a half of the oscillation period, especially when the high-side MOSFET is turned on.

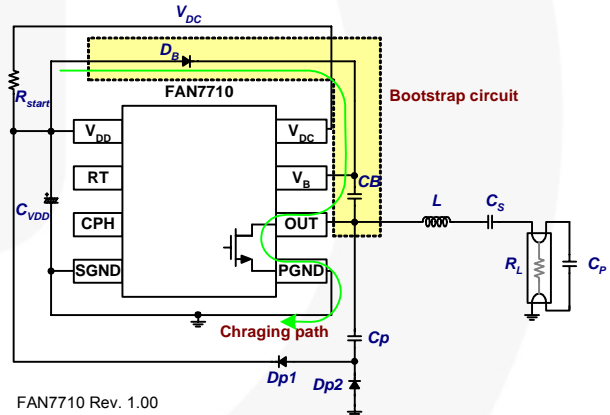

Figure 33. Implementation of Floating Power Supply Using the Bootstrap Method

Design Guide

1. Startup Circuit

The startup current (I_{ST}) has to be supplied to the IC through the startup resistor, R_{start} . Once operation starts, the power is supplied by the charge pump circuit. To reduce the power dissipation in R_{start} , select R_{start} as high as possible, considering the current requirements at startup. For 220V_{AC} power, the rectified voltage by the full-wave rectifier makes DC voltage, as shown in Equation 8. The voltage contains lots of AC component, due to poor regulation characteristic of the simple full-wave rectifier:

$$V_{DC} = \sqrt{2} \times 220[V] \cong 311[V] \quad (8)$$

Considering the selected parameters, R_{start} must satisfy the following equation:

$$\frac{V_{DC} - V_{DDTH(ST+)}}{R_{start}} > I_{ST} \quad (9)$$

From Equation 9, R_{start} is selected as:

$$\frac{V_{DC} - V_{DDTH(ST+)}}{I_{ST}} > R_{start} \quad (10)$$

Note that if choosing the maximum R_{start} , it takes a long time for V_{DD} to reach $V_{DDTH(ST+)}$. Considering V_{DD} rising time, R_{start} must be selected as shown in Figure 34. Another important concern for choosing R_{start} is the available power rating of R_{start} . To use a commercially available, low-cost 1/4Ω resistor, R_{start} must obey the following rule:

$$\frac{(V_{DC} - V_{CL})^2}{R_{start}} < \frac{1}{4} [W] \quad (11)$$

Assuming $V_{DC}=311V$ and $V_{CL}=15V$, the minimum resistance of R_{start} is about 350kΩ.

When the IC operates in shutdown mode due to thermal protection, open-lamp protection, or hard-switching protection; the IC consumes shutdown current, I_{SD} , which is larger than I_{ST} . To prevent restart during this mode, R_{start} must be selected to cover I_{SD} current consumption. The following equation must be satisfied:

$$\frac{V_{DC} - V_{DDTH(ST+)}}{I_{SD}} > R_{start} \quad (12)$$

From Equations 10 - 12; it is possible to select R_{start} :

(1) For safe startup without restart in shutdown mode:

$$4(V_{DC} - V_{CL})^2 < R_{start} < \frac{V_{DC} - V_{DDTH(ST+)}}{I_{SD}} \quad (13)$$

(2) For safe startup with restart from shutdown mode:

$$\frac{V_{DC} - V_{DDTH(ST+)}}{I_{SD}} < R_{start} < \frac{V_{DC} - V_{DDTH(ST+)}}{I_{ST}} \quad (14)$$

If R_{start} meets Equation 14, restart operation is possible. However, it is not recommended to choose R_{start} at that range since V_{DD} rising time could be long and increase the lamp's turn-on delay time, as depicted in Figure 34.

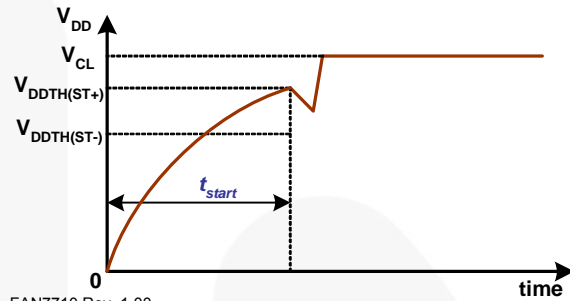

FAN7710 Rev. 1.00

Figure 34. V_{DD} Build-up

Figure 35 shows the equivalent circuit for estimating t_{start} . From the circuit analysis, V_{DD} variation versus time is given by:

$$V_{DD}(t) = (V_{DC} - R_{start} \cdot I_{ST}) \left(1 - e^{-t/(R_{start} \cdot C_{VDD})}\right) \quad (15)$$

where C_{VDD} is the total capacitance of the bypass capacitors connected between V_{DD} and GND.

From Equation 15, it is possible to calculate t_{start} by substituting $V_{DD}(t)$ with $V_{DDTH(ST+)}$:

$$t_{start} = -R_{start} \cdot C_{VDD} \cdot \ln \frac{V_{DC} - R_{start} \cdot I_{ST} - V_{DDTH(ST+)}}{V_{DC} - R_{start} \cdot I_{ST}} \quad (16)$$

In general, Equation 16 can be simplified as:

$$t_{start} \approx \frac{R_{start} \cdot C_{VDD} \cdot V_{DDTH(ST+)}}{V_{DC} - R_{start} \cdot I_{ST} - V_{DDTH(ST+)}} \quad (17)$$

Accordingly, t_{start} can be controlled by adjusting the value of R_{start} and C_{VDD} . For example, if $V_{DC}=311V$, $R_{start}=560k\Omega$, $C_{VDD}=10\mu F$, $I_{st}=120\mu A$, and $V_{DDTH(ST+)}=13.5V$; t_{start} is about 0.33s.

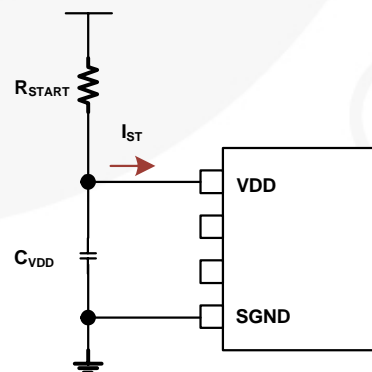

Figure 35. Equivalent Circuit During Startup

2. Current Supplied by Charge Pump

For the IC supply, the charge pump method is used in Figure 36. Since C_{CP} is connected to the half-bridge output, the supplied current by C_{CP} to the IC is determined by the output voltage of the half-bridge.

When the half-bridge output shows rising slope, C_{CP} is charged and the charging current is supplied to the IC. The current can be estimated as:

$$I = C_{CP} \frac{dV}{dt} \approx C_{CP} \frac{V_{DC}}{DT} \quad (18)$$

where DT is the dead time and dV/dt is the voltage variation of the half-bridge output.

When the half-bridge shows falling slope, C_{CP} is discharged through $Dp2$. Total supplied current, I_{total} , to the IC during switching period, t , is:

$$I_{total} = I \cdot DT = C_{CP} \cdot V_{DC} \quad (19)$$

From Equation 19, the average current, I_{avg} , supplied to the IC is obtained by:

$$I_{avg} = \frac{I_{total}}{t} = \frac{C_{CP} \cdot V_{DC}}{t} = C_{CP} \cdot V_{DC} \cdot f \quad (20)$$

For stable operation, I_{avg} must be higher than the required current. If I_{avg} exceeds the required current, the residual current flows through the shunt regulator implemented on the chip, which can cause unwanted heat generation. Therefore, C_{CP} must be selected considering stable operation and thermal generation.

For example, if $C_{CP}=0.5nF$, $V_{DC}=311V$, and $f=50kHz$, I_{avg} is $\sim 7.8mA$; it is enough current for stable operation.

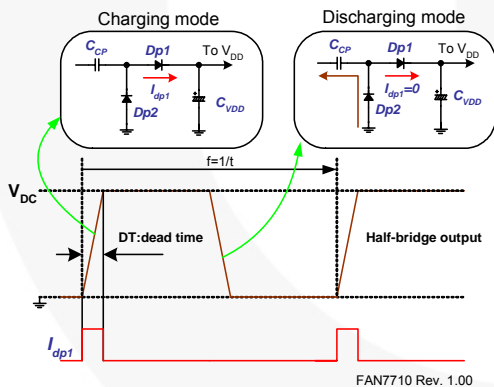

Figure 36. Charge Pump Operation

3. Lamp Turn-On Time

The turn-on time of the lamp is determined by supply build-up time t_{start} , preheating time, and ignition time; where t_{start} has been obtained by Equation 17. When the IC's supply voltage exceeds $V_{DDTH(ST+)}$ after turn-on or restart, the IC operates in preheating mode. This operation continues until CPH pin's voltage reaches $\sim 3V$. In this mode, CPH capacitor is charged by I_{PH} current, as depicted in Figure 37. The preheating time is achieved by calculating:

$$t_{preheat} = \frac{3 \times CPH}{I_{PH}} [\text{seconds}] \quad (21)$$

The preheating time is related to lamp life (especially filament). Therefore, the characteristics of a given lamp should be considered when choosing the time.

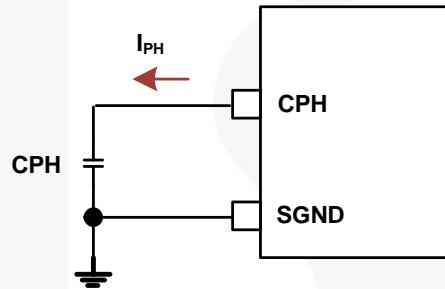

Figure 37. Preheating Timer

Compared to the preheating time, it is almost impossible to exactly predict the ignition time, whose definition is the time from the end of the preheating time to ignition. In general, the lamp ignites during the ignition mode. Therefore, assume that the maximum ignition time is the same as the duration of ignition mode, from 3V until CPH reaches 5V. Thus, ignition time can be defined as:

$$t_{ignition} = (5 - 3) \frac{CPH}{I_{IG}} = 2 \frac{CPH}{I_{IG}} \quad (22)$$

Note that in ignition mode, CPH is charged by I_{IG} , which is six times larger than I_{PH} . Consequently, total turn-on time is approximately V_{DD} Build-Time + Preheating Time + Ignition Time, or:

$$t_{ignition} = (5 - 3) \frac{CPH}{I_{IG}} = 2 \frac{CPH}{I_{IG}} [\text{seconds}] \quad (23)$$

Component List for 20W CFL Application ⁽³⁾

Part	Value	Note	Part	Value	Note
Resistor			Diode		
R1 ⁽⁴⁾	470kΩ	0.25W	D1	1N4007	1kV, 1A
R2	90kΩ	0.25W, 1%	D2	1N4007	1kV, 1A
Capacitor			D3	1N4007	1kV, 1A
C1	10μF/400V	Electrolytic Capacitor, 105°C	D4	1N4007	1kV, 1A
C2 ⁽⁵⁾	10μF/50V	Electrolytic Capacitor, 105°C	D5	UF4007	1kV, 1A
C3	100nF/25V	Miller Capacitor	D6	UF4007	1kV, 1A
C4	470pF/500V	Ceramic Capacitor	D7	UF4007	1kV, 1A
C5 ⁽⁶⁾	680nF/25V	Miller Capacitor, 5%	IC		
C6 ⁽⁷⁾	2.7nF/1kV	Miller Capacitor	IC	FAN7710V(L)	Ballast IC
C7 ⁽⁷⁾	33nF/630V	Miller Capacitor			
Inductor					
L2 ⁽⁷⁾	2.5mH	EE1916S,280T			

Notes:

- Refer to the Typical Application Circuit for 3U type CFL lamp provided in Figure 1.
- Refer to the Design Guide startup circuit in Figure 35. Due to reducing power loss on the startup resistor (R1) for high-efficiency systems, it is possible to use a higher resistor value than recommended. In this case, the IC doesn't reliably keep SD (shutdown) state for protection. Carefully select the startup resistor (R1) or use the recommended value (470k) to sufficiently supply shutdown current (I_{SD}) and startup current (I_{ST}).
- Normally, this component could be changed to a normal miller capacitor to increase system reliability instead of the electrolytic capacitor with high temperature characteristics.
- Temperature dependency of the capacitance is important to prevent destruction of the IC. Some capacitors show capacitance degradation in high temperatures and cannot guarantee enough preheating time to safely ignite the lamp during the ignition period at high temperatures. If the lamp does not ignite during the ignition period, the IC cannot guarantee ZVS operation. Thus, the peak current of the switching devices can be increased above allowable peak current level of the switching devices. Especially in high temperatures, the switching device can be easily destroyed. Consequently, CPH capacitor (C5) must be large enough to warm the filaments of the lamp up over the concerning temperature range.
- Consider the components (L2, C6, C7) of resonant tank variation over the concerning temperature range. Normally, these components would be changed toward increasing inductance and capacitance in high temperature. That means that the resonant frequency is decreased. In the lower resonant frequency condition, the preheating current reduces, so the resonant tank cannot supply enough to preheat the filaments before lamp turn on. If the preheating current is insufficient, the ignition voltage / current is increased. Check the ignition current in high temperature: the current capacity of internal MOSFETs on IC must be larger than ignition current.

Physical Dimensions

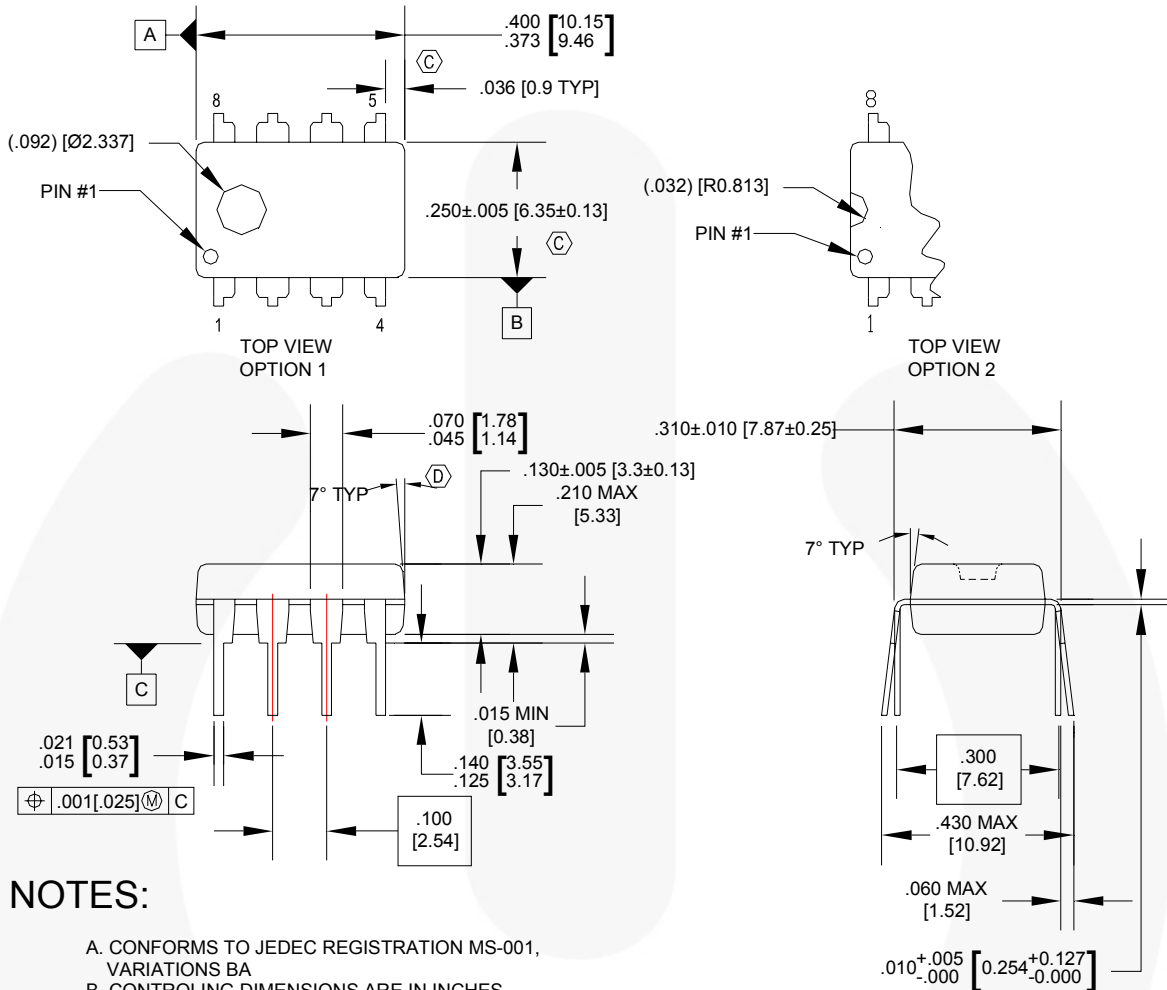

N08EREVG

Figure 38. 8-Lead, Dual Inline Package (DIP)





Package drawings are provided as a service to customers considering Fairchild components. Drawings may change in any manner without notice. Please note the revision and/or date on the drawing and contact a Fairchild Semiconductor representative to verify or obtain the most recent revision. Package specifications do not expand the terms of Fairchild's worldwide terms and conditions, specifically the warranty therein, which covers Fairchild products.

Always visit Fairchild Semiconductor's online packaging area for the most recent package drawings:
<http://www.fairchildsemi.com/packaging/>



TRADEMARKS

The following includes registered and unregistered trademarks and service marks, owned by Fairchild Semiconductor and/or its global subsidiaries, and is not intended to be an exhaustive list of all such trademarks.

- | | | | |
|-------------------------------------------------------------------------------------|--------------------------|-------------------------------------------------------------------------------------|---------------------------------------------------------------------------------------------------------|
| AccuPower™ | FlashWriter®* | PDP SPM™ |  SYSTEM GENERAL® |
| Auto-SPM™ | FPST™ | Power-SPM™ | The Power Franchise® |
| Build it Now™ | F-PFST™ | PowerTrench® |  the power franchise |
| CorePLUS™ | FRFET® | PowerXS™ | TinyBoost™ |
| CorePOWER™ | Global Power Resource SM | Programmable Active Droop™ | TinyBuck™ |
| CROSSVOLT™ | Green FPS™ | QFET® | TinyCalc™ |
| CTL™ | Green FPS™ e-Series™ | QS™ | TinyLogic® |
| Current Transfer Logic™ | Gmax™ | Quiet Series™ | TINYOPTO™ |
| DEUXPEED® | GTO™ | RapidConfigure™ | TinyPower™ |
| Dual Cool™ | IntelliMAX™ |  ™ | TinyPWM™ |
| EcoSPARK® | ISOPLANAR™ | Saving our world, 1mW/Wk/W at a time™ | TinyWire™ |
| EfficientMax™ | MegaBuck™ | SignalWise™ | TriFault Detect™ |
| EZSWITCH™* | MICROCOUPLER™ | SmartMax™ | TRUECURRENT™* |
|  ™ | MicroFET™ | SMART START™ | µSerDes™ |
|  ™ | MicroPak™ | SPM® |  SerDes® |
| Fairchild® | MicroPak2™ | STEALTH™ | UHC® |
| Fairchild Semiconductor® | MillerDrive™ | SuperFET™ | Ultra FRFET™ |
| FACT Quiet Series™ | MotionMax™ | SuperSOT™,3 | UniFET™ |
| FACT® | Motion-SPM™ | SuperSOT™-6 | VCX™ |
| FAST® | OptoHIT™ | SuperSOT™-8 | VisualMax™ |
| FastVCore™ | OPTOLOGIC® | SupreMOS™ | XS™ |
| FETBench™ | OPTOPLANAR® | SyncFET™ | |
| | | Sync-Lock™ | |

* Trademarks of System General Corporation, used under license by Fairchild Semiconductor.

DISCLAIMER

FAIRCHILD SEMICONDUCTOR RESERVES THE RIGHT TO MAKE CHANGES WITHOUT FURTHER NOTICE TO ANY PRODUCTS HEREIN TO IMPROVE RELIABILITY, FUNCTION, OR DESIGN. FAIRCHILD DOES NOT ASSUME ANY LIABILITY ARISING OUT OF THE APPLICATION OR USE OF ANY PRODUCT OR CIRCUIT DESCRIBED HEREIN; NEITHER DOES IT CONVEY ANY LICENSE UNDER ITS PATENT RIGHTS, NOR THE RIGHTS OF OTHERS. THESE SPECIFICATIONS DO NOT EXPAND THE TERMS OF FAIRCHILD'S WORLDWIDE TERMS AND CONDITIONS, SPECIFICALLY THE WARRANTY THEREIN, WHICH COVERS THESE PRODUCTS.

LIFE SUPPORT POLICY

FAIRCHILD'S PRODUCTS ARE NOT AUTHORIZED FOR USE AS CRITICAL COMPONENTS IN LIFE SUPPORT DEVICES OR SYSTEMS WITHOUT THE EXPRESS WRITTEN APPROVAL OF FAIRCHILD SEMICONDUCTOR CORPORATION.

As used herein:

1. Life support devices or systems are devices or systems which, (a) are intended for surgical implant into the body or (b) support or sustain life, and (c) whose failure to perform when properly used in accordance with instructions for use provided in the labeling, can be reasonably expected to result in a significant injury of the user.
2. A critical component in any component of a life support, device, or system whose failure to perform can be reasonably expected to cause the failure of the life support device or system, or to affect its safety or effectiveness.

ANTI-COUNTERFEITING POLICY

Fairchild Semiconductor Corporation's Anti-Counterfeiting Policy. Fairchild's Anti-Counterfeiting Policy is also stated on our external website, www.fairchildsemi.com, under Sales Support.

Counterfeiting of semiconductor parts is a growing problem in the industry. All manufacturers of semiconductor products are experiencing counterfeiting of their parts. Customers who inadvertently purchase counterfeit parts experience many problems such as loss of brand reputation, substandard performance, failed applications, and increased cost of production and manufacturing delays. Fairchild is taking strong measures to protect ourselves and our customers from the proliferation of counterfeit parts. Fairchild strongly encourages customers to purchase Fairchild parts either directly from Fairchild or from Authorized Fairchild Distributors who are listed by country on our web page cited above. Products customers buy either from Fairchild directly or from Authorized Fairchild Distributors are genuine parts, have full traceability, meet Fairchild's quality standards for handling and storage and provide access to Fairchild's full range of up-to-date technical and product information. Fairchild and our Authorized Distributors will stand behind all warranties and will appropriately address any warranty issues that may arise. Fairchild will not provide any warranty coverage or other assistance for parts bought from Unauthorized Sources. Fairchild is committed to combat this global problem and encourage our customers to do their part in stopping this practice by buying direct or from authorized distributors.

PRODUCT STATUS DEFINITIONS

Definition of Terms

Datasheet Identification	Product Status	Definition
Advance Information	Formative / In Design	Datasheet contains the design specifications for product development. Specifications may change in any manner without notice.
Preliminary	First Production	Datasheet contains preliminary data; supplementary data will be published at a later date. Fairchild Semiconductor reserves the right to make changes at any time without notice to improve design.
No Identification Needed	Full Production	Datasheet contains final specifications. Fairchild Semiconductor reserves the right to make changes at any time without notice to improve the design.
Obsolete	Not In Production	Datasheet contains specifications on a product that is discontinued by Fairchild Semiconductor. The datasheet is for reference information only.

Rev. I46

Looking for pricing, stock, or lifecycle information?

Click below to explore more details on WIN SOURCE:

- ⊖ [View FAN7710VLN on WIN SOURCE](#)
- ⊖ [Fairchild/ON Semiconductor Information](#)

Optimize Your Supply Chain with WIN SOURCE Solutions

- ✓ Global Sourcing Solution
- ✓ Obsolete Management
- ✓ Cost Control Management
- ✓ Shortage Management
- ✓ Alternative Solution
- ✓ Excess Inventory Management