



**THE DATASHEET OF  
F2M03GLA-S01**



## Features

- Fully qualified product with Bluetooth® v2.0+EDR, CE, FCC, and IC
- Low power consumption
- Integrated high output antenna
- Transmit power up to +6.3dBm
- Class1/ 2/ 3 Configurable
- Range: up to 250m (line of sight)
- Piconet and Scatternet capability, supports up to 7 slaves
- Require only few external components
- Industrial temperature range -40°C to +85°C
- USB v2.0 compliant
- Extensive digital and analog I/O interface
- PCM interface for up to 3 simultaneous voice channels
- Large external memory for custom applications
- Support for 802.11b/g Co-Existence
- RoHS compliant
- REACH compliant

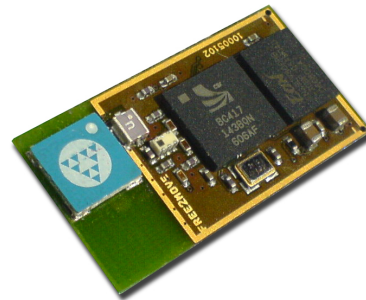

## Applications

- Industrial and domestic appliances
- Cable replacement
- Medical systems
- Automotive applications
- Stand-alone sensors
- Embedded systems
- Cordless headsets
- Computer peripherals (Mice, Keyboard, USB dongles, etc.)
- Handheld, laptop and desktop computers
- Mobile phones

## General Description

F2M03GLA is a Low power embedded Bluetooth® v2.0+EDR module with built-in high output antenna. The module is a fully Bluetooth® compliant device for data and voice communication. With a transmit power of up to +6.3dBm and receiver sensibility of down to -83dBm combined with low power consumption the F2M03GLA is suitable for the most demanding applications. Developers can easily implement a wireless solution into their product even with limited knowledge in Bluetooth® and RF. The module is fully Bluetooth® v2.0+EDR qualified and it is certified according to CE, FCC and IC, which give fast and easy Plug-and-Go implementation and short time to market.

The F2M03GLA comes with an on board highly efficient omni-directional antenna that simplifies the integration for a developers Bluetooth® solution. The high output power combined with the low power consumption makes this module ideal for handheld applications and other battery powered devices.

F2M03GLA can be delivered with the exceedingly reliable and powerful easy-to-use Wireless UART firmware implementing the Bluetooth® Serial Port Profile (SPP).



The Bluetooth® word mark and logos are registered trademarks owned by Bluetooth SIG, Inc. and any use of such marks by Free2move is under license. Other trademarks and trade names are those of their respective owners.

## Table of contents

<b>1</b>	<b>Device pinout</b> .....	<b>3</b>
<b>2</b>	<b>Device terminal functions</b> .....	<b>4</b>
<b>3</b>	<b>Electrical Characteristics</b> .....	<b>5</b>
<b>4</b>	<b>Radio Characteristics</b> .....	<b>8</b>
<b>5</b>	<b>Firmware versions</b> .....	<b>9</b>
5.1	Wireless UART .....	11
5.2	HCI .....	16
<b>6</b>	<b>Device terminal description</b> .....	<b>19</b>
6.1	UART Interface.....	19
6.2	USB Interface .....	20
6.3	Serial Peripheral Interface .....	24
6.4	I <sup>2</sup> C Interface.....	25
6.5	PCM.....	25
6.6	PIOs.....	32
6.7	Power supply .....	33
<b>7</b>	<b>Application information</b> .....	<b>34</b>
7.1	Recommended land pattern .....	34
7.2	Layout guidelines.....	35
7.3	Typical application schematic.....	36
<b>8</b>	<b>Package information</b> .....	<b>37</b>
<b>9</b>	<b>Certifications</b> .....	<b>38</b>
9.1	Bluetooth®.....	38
9.2	CE.....	38
9.3	FCC .....	38
9.4	IC.....	39
<b>10</b>	<b>RoHS Statement</b> .....	<b>40</b>
<b>11</b>	<b>REACH Statement</b> .....	<b>40</b>
<b>12</b>	<b>Tape and Reel information</b> .....	<b>41</b>
12.1	Package Tape dimensions .....	41
12.2	Reel dimensions .....	41
<b>13</b>	<b>Ordering information</b> .....	<b>42</b>
<b>14</b>	<b>Document history</b> .....	<b>42</b>
<b>15</b>	<b>Acronyms and definitions</b> .....	<b>43</b>

## 1 Device pinout

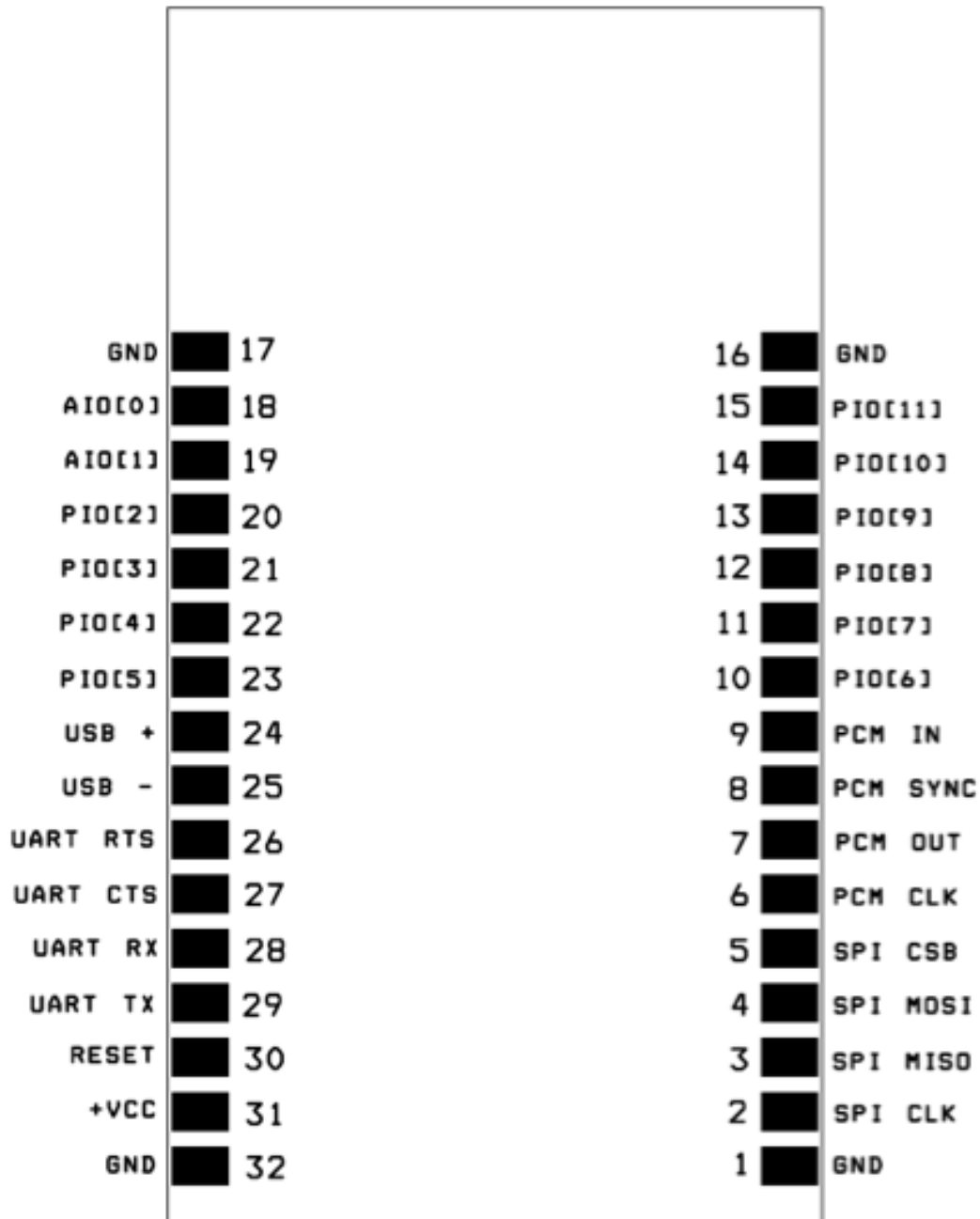

Pinout of the F2M03GLA seen from the component side [TOP VIEW]

## 2 Device terminal functions

Ground	Pin	Pin type	Description
GND	1,16,17,32	VSS	Ground connections
Power supplies	Pin	Pin type	Description
+VCC	31	VDD	Positive voltage supply (3.0-3.6)
Analog I/O	Pin	Pin type	Description
AIO(0)	18	Bi-directional	Programmable input/output line also possible to use as digital I/O
AIO(1)	19	Bi-directional	Programmable input/output line also possible to use as digital I/O
Reset	Pin	Pin type	Description
RESET	30	CMOS input with internal pull-up (10kΩ)	Reset if low. Input debounced so must be low for >5ms to cause a reset
Test and debug	Pin	Pin type	Description
SPI MISO	3	CMOS output, tristatable with weak internal pull-down	Serial Peripheral Interface data output
SPI CSB	5	CMOS input with weak internal pull-up	Chip select for Synchronous Serial Interface, active low
SPI CLK	2	CMOS input with weak internal pull-down	Serial Peripheral Interface clock
SPI MOSI	4	CMOS input with weak internal pull-down	Serial Peripheral Interface data input
UART	Pin	Pin type	Description
UART CTS	27	CMOS input with weak internal pull-down	UART clear to send active low
UART TX	29	CMOS output	UART data output active high
UART RTS	26	CMOS output, tristatable with internal pull-up	UART request to send active low
UART RX	28	CMOS input with weak internal pull-down	UART data input active high
PCM	Pin	Pin type	Description
PCM_OUT	7	CMOS output, tristatable with internal weak pull down	Synchronous data output
PCM_SYNC	8	Bi-directional with weak internal pull-down	Synchronous data SYNC
PCM_IN	9	CMOS input, with weak internal pull-down	Synchronous data input
PCM_CLK	6	Bi-directional with weak internal pull-down	Synchronous data clock
USB	Pin	Pin type	Description
USB +	24	Bi-directional	USB data plus
USB -	25	Bi-directional	USB data minus
PIO	Pin	Pin type	Description
PIO(11)	15	Bi-directional with programmable weak internal pull-up/down	Programmable input/output line
PIO(10)	14	Bi-directional with programmable weak internal pull-up/down	Programmable input/output line
PIO(9)	13	Bi-directional with programmable weak internal pull-up/down	Programmable input/output line
PIO(8)	12	Bi-directional with programmable weak internal pull-up/down	Programmable input/output line
PIO(7)	11	Bi-directional with programmable weak internal pull-up/down	Programmable input/output line
PIO(6)/WLAN_Active/ Ch_Data	10	Bi-directional with programmable weak internal pull-up/down	Programmable input/output line or Optionally WLAN_Active/Ch_Data input for co-existence signalling
PIO(5)/BT_Active	23	Bi-directional with programmable weak internal pull-up/down	Programmable input/output line or Optionally BT_Active output for co-existence signalling
PIO(4)/ BT_Priority/Ch_Clk	22	Bi-directional with programmable weak internal pull-up/down	Programmable input/output line or Optionally BT_Priority/Ch_Clk output for co-existence signalling
PIO(3)	21	Bi-directional with programmable weak internal pull-up/down	Programmable input/output line
PIO(2)	20	Bi-directional with programmable weak internal pull-up/down	Programmable input/output line
Not connected	Pin	Pin type	Description
NC		Not connected	Soldering pads for stability

### 3 Electrical Characteristics

#### Absolute Maximum Ratings

Rating	Min	Max
Storage Temperature	-40°C	+85°C
Breakdown supply voltage	-0.4V	5.60V

#### Recommended Operating Conditions\*

Rating	Min	Max
Operating temperature range	-40°C	+85°C
Supply voltage	3.1V	3.6V

\*F2M03GLA meet the Bluetooth® v2.0+EDR specification when used in the recommended operating condition.

#### Input/Output Terminal Characteristics

Digital Terminals	Min	Typ	Max	Unit
<b>Input Voltage</b>				
V <sub>IL</sub> input logic level low, 2.7V ≤ VDD ≤ 3.0V	-0.4	-	+0.8	V
V <sub>IH</sub> input logic level high	0.7VDD	-	VDD+0.4	V
<b>Output Voltage</b>				
V <sub>OL</sub> output logic level low, (I <sub>o</sub> = 4.0mA), 2.7V ≤ VDD ≤ 3.0V	-	-	0.2	V
V <sub>OH</sub> output logic level high, (I <sub>o</sub> = 4.0mA), 2.7V ≤ VDD ≤ 3.0V	VDD-0.2	-	-	V
<b>Input and tristate current</b>				
Strong pull-up	-100	-40	-10	mA
Strong pull-down	+10	+40	+100	mA
Weak pull-up	-5.0	-1.0	-0.2	mA
Weak pull-down	+0.2	+1.0	+5.0	mA
I/O pad leakage current	-1	0	+1	mA
C <sub>I</sub> Input Capacitance	1.0	-	5.0	pF

USB Terminals	Min	Typ	Max	Unit
<b>USB Terminals</b>				
VDD for correct USB operation	3.1	-	3.6	V
<b>Input threshold</b>				
V <sub>IL</sub> input logic level low	-	-	0.3VDD	V
V <sub>IH</sub> input logic level high	0.7VDD	-	-	V
<b>Input leakage current</b>				
C <sub>I</sub> Input capacitance	2.5	-	10.0	pF
<b>Output levels to correctly terminated USB Cable</b>				
V <sub>OL</sub> output logic level low	0	-	0.2	V
V <sub>OH</sub> output logic level high	2.8	-	VDD	V

#### Notes:

Current drawn into a pin is defined as positive; current supplied out of a pin is defined as negative.

**Input/Output Terminal Characteristics (Continued)**

Auxiliary ADC, 8-bit resolution		Min	Typ	Max	Unit
<b>Resolution</b>		-	-	8	Bits
Input voltage range (LSB size = 1.8/255= 7.1mV)		0	-	1.8	V
Accuracy (Guaranteed monotonic)	INL	-1	-	1	LSB
	DNL	0	-	1	LSB
Offset		-1	-	1	LSB
Gain Error		-0.8	-	0.8	%
Input Bandwidth		-	100	-	KHz
Conversion time		-	2.5	-	µS
Sample rate*		-	-	700	Sample/s

\*The ADC is accessed through the VM function. The sample rate given is achieved as a part of this function

**Average current consumption**

VDD = 3.3V Temperature = 20 °C

Measured using Wireless UART firmware v4 at a range of 5m.

Slave:

Mode	Average (mA)
No connection (default settings)	1,6
Connected, no data transfer	26
Connected, no data transfer Sniff mode 125 ms interval	3,2
Connected, 115.2 kbit/s master to slave	33
Connected, 115.2 kbit/s slave to master	35
Connected, 115.2 kbit/s full duplex	35
Connected, 115.2 kbit/s master to slave Sniff mode 125 ms interval	23
Connected, 115.2 kbit/s slave to master Sniff mode 125 ms interval	18
Connected, 115.2 kbit/s full duplex Sniff mode 125 ms interval	30
SCO connection HV1, no data transfer	50
SCO connection HV3, no data transfer	36
SCO connection HV3, no data transfer Sniff mode 30 ms interval	29
SCO connection HV3, 115.2 kbit/s master to slave	42

Master:

Mode	Average (mA)
No connection (default settings)	44
Connected, no data transfer	7
Connected, no data transfer Sniff mode 200 ms interval	3,5
Connected, 115.2 kbit/s master to slave	35
Connected, 115.2 kbit/s slave to master	31
Connected, 115.2 kbit/s full duplex	35
Connected, 115.2 kbit/s master to slave Sniff mode 125 ms interval	26
Connected, 115.2 kbit/s slave to master Sniff mode 125 ms interval	13
Connected, 115.2 kbit/s full duplex Sniff mode 125 ms interval	29
SCO connection HV1, no data transfer	50
SCO connection HV3, no data transfer	31
SCO connection HV3, no data transfer Sniff mode 30 ms interval	31
SCO connection HV3, 115.2 kbit/s master to slave	49

**Peak current consumption**

VDD = 3.3V Temperature = 20 °C

Mode	Typ	Unit
Peak consumption during RF peaks	75	mA

**Leakage current**

VDD = 3.3V Temperature = 20 °C

Mode	Typ	Unit
Reset LOW	200	mA
Deep sleep	275	mA

## 4 Radio Characteristics

Radio Characteristics VDD= 3.3V Temperature= +20°C				
	Min	Typ	Max	Unit
Operating Frequency	2402	-	2480	MHz
Transmit Power	-20	-	+6.3	dBm
Sensitivity at 0.1% BER		-83		dBm

### Note:

The F2M03GLA has a maximum transmit power of +6.3dBm and is certified according to the Bluetooth® v2.0+EDR specification as a Class1 device. It is though possible to restrict the maximum transmit power to comply with either a Class2 or Class3 device upon configuration.

### Bluetooth® Specification

Class of device	Maximum transmit power
Class1	+20dBm
Class2	+4dBm
Class3	0dBm

## 5 Firmware versions

F2M03 is supplied with Bluetooth® stack firmware, which runs on the internal RISC micro controller of the Bluetooth® module. This chapter includes an overview of the different options for more in depth information please use separate firmware datasheets provided by Free2move.

All firmware versions are compliant with the Bluetooth® specification v2.0. The F2M03 software architecture allows Bluetooth® processing to be shared between the internal micro controller and a host processor. Depending on application the upper layers of the Bluetooth® stack (above HCI) can execute on-chip or on the host processor.

Running the upper stack on F2M03 module reduces (or eliminates, in the case of a on module application) the need for host-side software and processing time.

The integration approach depends on the type of product being developed. For example, performance will depend on the integration approach adopted. In general Free2move offers four categories of Bluetooth® stack firmware:

- Wireless UART; offers a transparent UART interface to the Bluetooth® channel. There is no need for additional drivers or Bluetooth® software on the host.
- Embedded module solutions offer an application to run on the module. There is no need for an external host (E.g. a Bluetooth® headset).
- Two-processor solution involving a host and host controller, where the higher layers of the Bluetooth® stack has to be implemented on the host.
- Two-processor embedded solution offers a host with limited resources to gain access to a Bluetooth® stack, with the higher layers on-chip, via a special API.

The protocol layer models for the different Bluetooth® stack firmware categories can be represented as shown in the figures below.

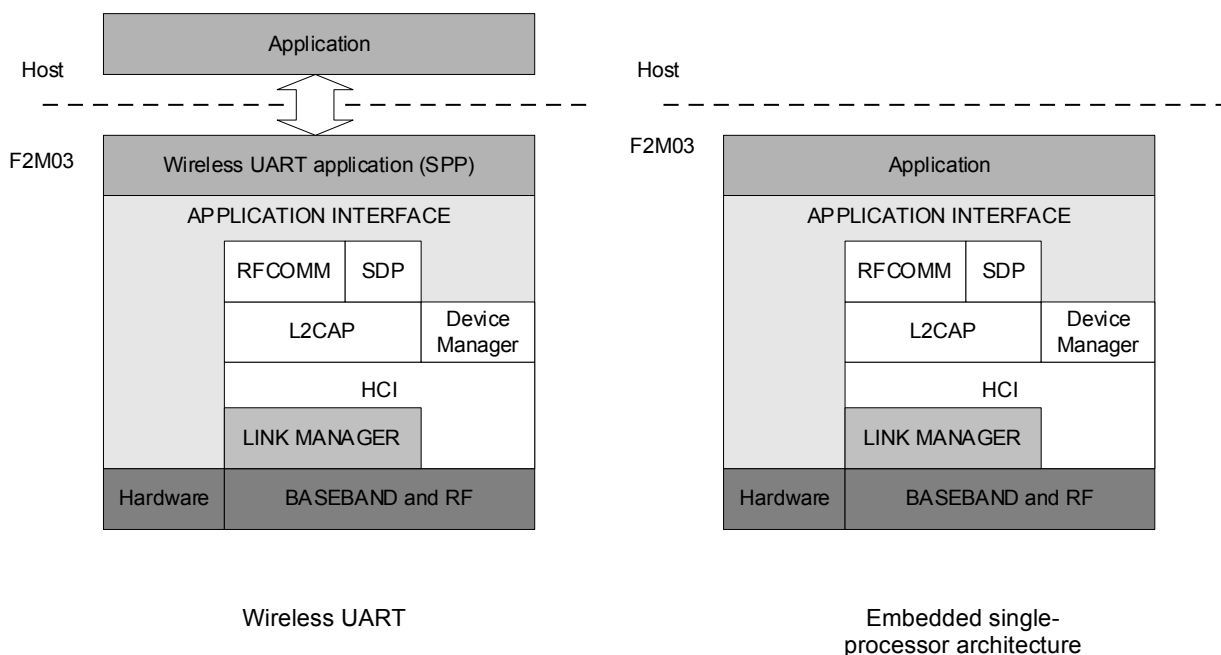

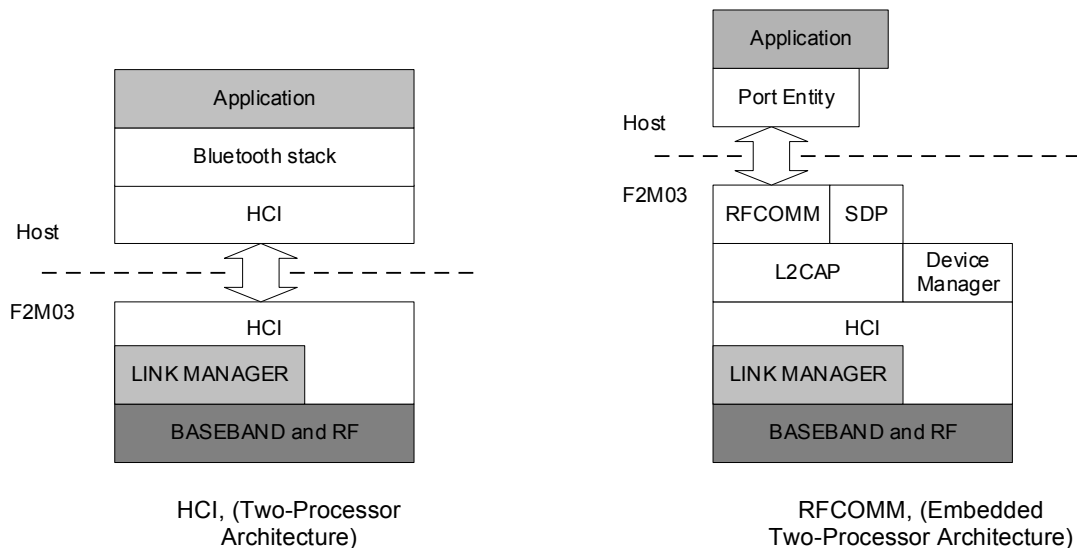

### Wireless UART

Free2move's Wireless UART (WU) firmware is intended to replace the serial cable(s) connecting portable and/or fixed electronic devices. Key features are robustness, high configurability, high security, low complexity and low power. The WU firmware is compliant with the Bluetooth® Serial Port Profile (SPP) for setting up emulated serial cable connections between connected devices. There is no additional need for drivers or an external host with Bluetooth® software when using the WU firmware. When a successful Bluetooth® connection is established the data channel and the voice channel can be used simultaneously or separately. All information sent/received at the data/voice interface of the WU unit is exchanged transparently via Bluetooth® with the connected remote device.

### HCI (Standard Two-Processor Solution)

For the standard two-processor solution, where the split between higher and lower layers of the stack takes place at the HCI, a complete Bluetooth® stack is needed in the external host. It is often preferable to use this solution when the host is a personal computer of some description. However, in general this category can include any computing platform with communications capability that is not resource limited. Free2move do not offer the host stack.

### Embedded Solution

This version of the stack firmware requires no host processor. All software layers, including application software, run on the internal RISC processor in a protected user software execution environment.

The embedded solution can be used for a single chip Bluetooth® product. One example is a cordless headset. However this solution is equally applicable to any small wireless device that would benefit from a single processor solution.

Free2move can offers among others the following single chip solutions upon a custom request\*:

- Headset / Hands Free
- Human Interface Device; Mouse, keyboard etc (HID)
- Dial Up Network (DUN)
- Audio Gateway Profile (AGP)
- OBEX
- Onboard application (development of customer specific applications)

\*Please consult your reseller for more information about custom firmwares.

## 5.1 Wireless UART

Free2move's Wireless UART (WU) firmware is intended to replace the serial cable(s) connecting portable and/or fixed electronic devices. Key features are robustness, high configurability, high security, low complexity and low power.

The WU firmware is compliant with the Bluetooth® Serial Port Profile (SPP) for setting up emulated serial cable connections between connected devices. There is no additional need for drivers or an external host with Bluetooth® software when using the WU firmware.

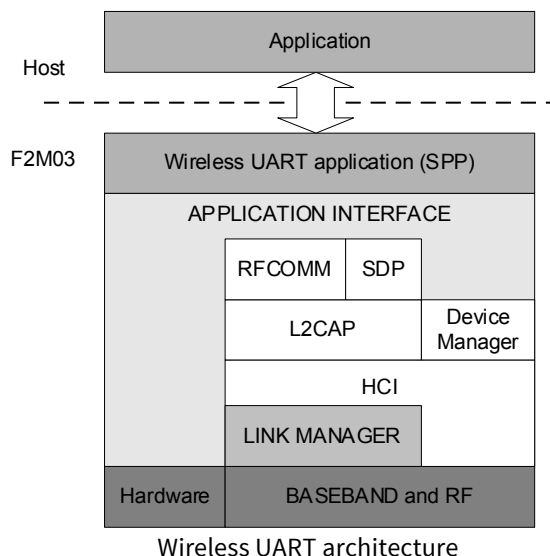

The WU application runs on top of an embedded Bluetooth® v2.0 + EDR compliant stack, including protocols up to the RFCOMM layer. Point-to-point connections are supported. This means that a unit running WU can be either a master or slave unit.

The WU firmware offers one asynchronous data channel and one synchronous voice channel, both channels capable of full duplex transmissions.

When a successful Bluetooth® connection is established the data channel and the voice channel can be used simultaneously or separately. All information sent/received at the data/voice interface of the WU unit is exchanged transparently via Bluetooth® with the connected remote device.

The WU unit is set to operate in a default mode that allows the user to communicate via the asynchronous data channel over Bluetooth®, as soon as a successful connection has been established. This can be achieved without sending any configuration commands to the WU firmware. However, as long as there is no Bluetooth® connection established, it is possible to configure the WU firmware via hex commands (described in the document *Wireless\_UART\_protocol*) or using a Windows configuration software.

### 5.1.1 General I/O

General I/O interfaces are used for different purposes between the WU firmware and the Host:

- Asynchronous data interface – configuration of the WU firmware or exchange transparent digital information between the connected Bluetooth® devices.
- Synchronous voice interface – exchange transparent voice information between the connected Bluetooth® devices.
- Bluetooth® connectivity PIO interfaces – indication and disconnection of the established Bluetooth® connection.
- Emulate serial handshaking PIO lines interface – DTE or DCE serial handshake emulation between the connected Bluetooth® devices.

UART interface (Asynchronous data and configuration):

UART	Signal Direction	Active (TTL)	Description
TX	Output	High	UART transmit data
RX	Input	High	UART receive data
RTS	Output	Low	UART request to send
CTS	Input	Low	UART clear to send

Voice interface:

CODEC I/O	Signal Direction	Description
MIC_P	Input (analogue)	Microphone input positive
MIC_N	Input (analogue)	Microphone input negative
AUX_DAC	Output (analogue)	Microphone input bias
SPKR_P	Output (analogue)	Speaker output positive
SPKR_N	Output (analogue)	Speaker output negative

PIOs are used to control/monitor the Bluetooth® connectivity of the WU firmware.

PIO	Signal Direction	Active (TTL)	Description
2	Input	High	Request to close the current Bluetooth® connection to the remote device.
3	Output	High	Indicates that a successful Bluetooth® connection is established with a remote device.

To prevent connections or to close the current Bluetooth® connection PIO[2] can be set high.

PIO[3] is held low as long as there is no Bluetooth® connection. As soon as a successful Bluetooth® connection has been established with a remote device, PIO[3] goes high.

PIOs can also be used to emulate serial handshaking lines between the connected Bluetooth® devices. Emulation can either be DTE or DCE.

Emulated Signal	PIO	Signal Direction Emulate DTE	Signal Direction Emulate DCE	Active (TTL)
RI	4	Input	Output	High
DTR	5	Output	Input	High
DCD	6	Input	Output	High
DSR	7	Input	Output	High

---

While the handshaking lines are transparent to the data channel these I/O may also be used to transfer digital signals between two Free2move devices running WU

### 5.1.2 Settings

The default settings allow the user to communicate via Bluetooth®, without sending any configuration commands, as soon as a successful connection has been established. Information sent and received on the serial interface of the WU unit at 38400 bps is transmitted transparently between the two connected devices. The default settings are valid as long as the user has made no configuration.

When there is no Bluetooth® connection established it is possible to configure the WU firmware via commands sent on the serial interface. All settings changed by the user are stored in persistent memory.

The following serial settings are used for configuration mode and are not configurable:

Parameter	Default Value
Baud rate	38400
Data bits	8
Parity	None
Stop bits	1
Hardware flow control	On

To be able to send commands to the Wireless UART firmware, it must be set in *Host Controlled Mode* (HCM). As previously described the Wireless UART firmware can only enter HCM when no Bluetooth® connection is established.

Once entered HCM there are several commands that can be issued:

- Configuration commands
- Software / Hardware reboot
- Inquiry (search for Bluetooth® devices in the neighborhood)
- Pairing (device security - authentication and encryption)
- Advanced configuration commands
- SCO commands
- Information commands
- Control commands

### **Configuration Commands**

There are several settings stored in the Wireless UART firmware that can be read and modified by using the configuration commands.

Examples of these settings are:

- Local Bluetooth® name
- Local SDP-service name
- Operating mode
- Serial port settings
- Bluetooth® security settings (authentication, encryption)

There are two normal operating modes:

- Connecting mode – Bluetooth® master
- Endpoint mode – Bluetooth® slave

In Connecting mode the Wireless UART firmware will continuously try to establish a Bluetooth® connection to a specified remote Bluetooth® device in the neighborhood (Bluetooth® master).

In Endpoint mode the Wireless UART firmware may accept connections from remote Bluetooth® devices. A connection request will be accepted when the specified rules are fulfilled (Bluetooth® slave).

### ***Software / Hardware Reboot***

This option gives the ability to be able to reboot the module via software commands.

### ***Inquiry***

Search for other Bluetooth® devices in the neighborhood.

There are three configuration parameters:

- How many seconds the search should be active
- A filter, used when searching for devices of as certain class
- The possibility to include the Bluetooth® name of the discovered devices

### ***Pairing***

When authentication is enabled, the devices must be paired before a successful connection can be established.

The Wireless UART firmware can either initiate pairing with a remote device or accept pairing requests.

During a pairing PIN codes are exchanged between the local and remote device. A successful pairing requires identical PIN codes. The result of the pairing attempt will be returned to the Host. If pairing was successful, a unique link key has been generated and saved in non-volatile memory. The link key is used in the connection establishment procedure for secure verification of the relationship between the paired devices.

The Wireless UART firmware allows the user to be paired with one device at a time. The last pin code entered and link key generated are saved.

### ***Advanced configuration***

Includes among others commands for enabling power save modes, fine tune performance, enabling modem emulation and changing transmit power.

### ***SCO commands***

Makes it possible to establish full duplex audio connections between two WU units.

### 5.1.3 Performance

The WU firmware is a complete on-chip application; limited resources restrict the maximum throughput. The table below shows the maximum achieved throughput when streaming data between two connected WU v4.00 devices at close range.

Direction	Baud Rate	Maximum Throughput (kbit/s (throughput mode))	Maximum Throughput (kbit/s) (latency mode)
Master to Slave	57600	~57.6	~57.6
Slave to Master	57600	~57.6	~57.6
Full duplex	57600	~57.6	~50.5
Master to Slave	115200	~115.1	~93.9
Slave to Master	115200	~115.1	~79.6
Full duplex	115200	~114.5	~42.0
Master to Slave	230400	~223.1	~158.0
Slave to Master	230400	~221.4	~117.7
Full duplex	230400	~172.7	~86.2
Master to Slave	460800	~228.6	~206.7
Slave to Master	460800	~222.7	~154.1
Full duplex	460800	~173.3	~109.8
Master to Slave	921600	~240.1	~235.7
Slave to Master	921600	~235.4	~186.0
Full duplex	921600	~174.7	~150.5

### 5.1.4 Configuration

The F2M03 can either be configured using hex commands described in the document “*Wireless\_UART\_protocol.pdf*” or using the Windows configuration software. The configuration software can be downloaded from [www.free2move.se](http://www.free2move.se)

## 5.2 HCI

In this implementation the internal processor of the module runs the Bluetooth® stack up to the Host Controller Interface (HCI) as specified in the Bluetooth® specification V1.1. The external host processor must provide all upper Bluetooth® stack layers. Free2move do not offer a host stack solution for an external Host.

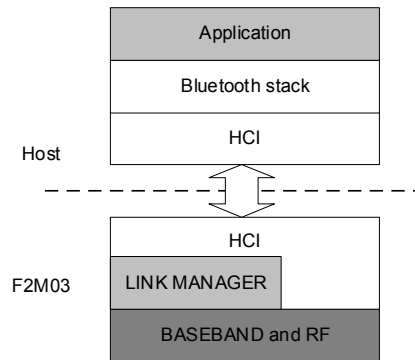

Standard Two-Processor  
Architecture

### 5.2.1 Standard Bluetooth® Functionality

Bluetooth® v2.0 + EDR mandatory functionality:

- Adaptive frequency hopping (AFH), including classifier
- Faster connection - enhanced inquiry scan (immediate FHS response)
- LMP improvements
- Parameter ranges

Optional Bluetooth® v2.0 + EDR functionality supported:

- Adaptive Frequency Hopping (AFH) as Master and Automatic Channel Classification
- Fast Connect - Interlaced Inquiry and Page Scan plus RSSI during Inquiry
- Extended SCO (eSCO), eV3 +CRC, eV4, eV5
- SCO handle
- Synchronisation

The firmware has been written against the Bluetooth® v2.0 + EDR specification.

- Bluetooth® components: Baseband (including LC), LM and HCI
- Standard USB (v1.1) and UART (H4) HCI Transport Layers
- All standard radio packet types
- Full Bluetooth® data rate, enhanced data rates of 2 and 3Mbps<sup>(1)</sup>
- Operation with up to seven active slaves<sup>(1)</sup>
- Operation with up to three SCO links, routed to one or more slaves
- Scatternet v2.5 operation
- Maximum number of simultaneous active ACL connections: 7<sup>(2)</sup>
- Maximum number of simultaneous active SCO connections: 3<sup>(2)</sup>
- Role switch: can reverse Master/Slave relationship
- All standard SCO voice coding, plus “transparent SCO”
- Standard operating modes: Page, Inquiry, Page-Scan and Inquiry-Scan
- All standard pairing, authentication, link key and encryption operations

- Standard Bluetooth® power saving mechanisms: Hold, Sniff and Park modes, including “Forced Hold”
- Dynamic control of peers’ transmit power via LMP
- Master/Slave switch
- Broadcast
- Channel quality driven data rate (CQDDR)
- All standard Bluetooth® Test Modes
- Standard firmware upgrade via USB (DFU)

**Note:**

<sup>(1)</sup>Maximum allowed by Bluetooth® v2.0 + EDR specification.

<sup>(2)</sup>F2M03 supports all combinations of active ACL and SCO channels for both Master and Slave operation, as specified by the Bluetooth® v2.0 + EDR specification.

### 5.2.2 Extra Functionality

The firmware extends the standard Bluetooth® functionality with the following features:

- Supports BlueCore Serial Protocol (BCSP) - a proprietary, reliable alternative to the standard Bluetooth® (H4) UART Host Transport.
- Provides a set of approximately 50 manufacturer-specific HCI extension commands. This command set (called BCCMD – “BlueCore Command”) provides:
  - Access to the module’s general-purpose PIO port
  - The negotiated effective encryption key length on established Bluetooth® links
  - Access to the firmware’s random number generator
  - Controls to set the default and maximum transmit powers - these can help to reduce interference between overlapping, fixed-location piconets
  - Dynamic UART configuration
  - Radio transmitter enable/disable - a simple command connects to a dedicated hardware switch that determines whether the radio can transmit.
- The firmware can read the voltage on a pair of the module’s external pins (normally used to build a battery monitor, using either VM or host code).
- A block of BCCMD commands provides access to the module’s Persistent Store (PS) configuration database. The database sets the device’s Bluetooth® address, Class of Device, radio (transmit class) configuration, SCO routing, LM, USB and DFU constants, etc.
- A UART “break” condition can be used in three ways:
  - Presenting a UART break condition to the module can force the module to perform a hardware reboot.
  - Presenting a break condition at boot time can hold the module in a low power state, preventing normal initialisation while the condition exists.
  - With BCSP, the firmware can be configured to send a break to the host before sending data - normally used to wake the host from a Deep Sleep state.
- The DFU standard has been extended with public/private key authentication, allowing manufacturers to control the firmware that can be loaded onto their Bluetooth® modules.
- A modified version of the DFU protocol allows firmware upgrade via the module’s UART.
- A block of “radio test” or Built-In Self-Test (BIST) commands allows direct control of the module’s radio. This aids the development of modules’ radio designs and can be used to support Bluetooth® qualification.
- Virtual Machine (VM). The VM allow development of customer applications on the module. Although the VM is mainly used with “RFCOMM builds” (alternative firmware builds providing L2CAP, SDP and RFCOMM), the VM can be used with this build to perform simple tasks such as flashing LEDs via the module’s PIO port.
- Hardware low power modes: Shallow Sleep and Deep Sleep. The module drops into modes that significantly reduce power consumption when the software goes idle.

SCO channels are normally routed over HCI (over BCSP). However, up to three SCO channels can be routed over the module's single PCM port (at the same time as routing any other SCO channels over HCI).

## 6 Device terminal description

### 6.1 UART Interface

The F2M03 Bluetooth® module's Universal Asynchronous Receiver Transmitter (UART) interface provides a simple mechanism for communicating with other serial devices using the RS232 standard<sup>(1)</sup>.

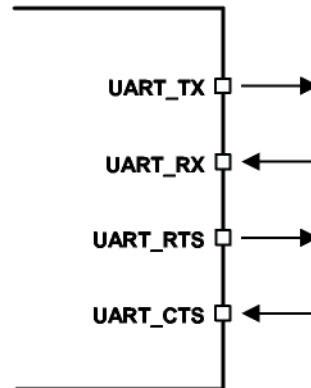

Universal Asynchronous Receiver

Four signals are used to implement the UART function, as shown in the figure above. When F2M03 is connected to another digital device, UART\_RX and UART\_TX transfer data between the two devices. The remaining two signals, UART\_CTS and UART\_RTS, can be used to implement RS232 hardware flow control where both are active low indicators. All UART connections are implemented using CMOS technology and have signalling levels of 0V and VDD. UART configuration parameters, such as Baud rate and packet format, are set by Free2move firmware.

Note:

In order to communicate with the UART at its maximum data rate using a standard PC, an accelerated serial port adapter card is required for the PC.

<sup>(1)</sup> Uses RS232 protocol but voltage levels are 0V to VDD, (requires external RS232 transceiver IC)

Parameter		Possible Values
Baud Rate	Minimum	1200 Baud ( $\leq 2\%$ Error)
	Maximum	9600 Baud ( $\leq 1\%$ Error)
Flow Control		RTS/CTS or None
Parity		None, Odd or Even
Number of Stop Bits		1 or 2
Bits per channel		8

Possible UART Settings

The UART interface is capable of resetting the Free2move module upon reception of a break signal. A Break is identified by a continuous logic low on the UART\_RX terminal, as shown in figure below. If tBRK is longer than a special value, defined by the Free2move firmware a reset will occur. This feature allows a host to initialise the system to a known state. Also, the F2M03 can emit a Break character that may be used to wake the Host. The above capabilities are not supported in the standard firmware, please contact Free2move for more information.



Break signal

## 6.2 USB Interface

F2M03 contain a full-speed (12Mbits/s) USB interface, capable of driving a USB cable directly. No external USB transceiver is required. The device operates as a USB peripheral, responding to requests from a master host controller such as a PC. Both the OHCI and the UHCI standards are supported. The set of USB endpoints implemented behave as specified in the USB section of the Bluetooth® specification v2.0+EDR. As USB is a master-slave orientated system, F2M03 only supports USB slave operation.

**Note:** The USB interface can only be used with the HCI firmware

### 6.2.1 USB Data Connections

The USB data lines emerge as pins USB\_DP (USB +) and USB\_DN (USB -) on the module. These terminals are connected to the internal USB I/O buffers of F2M03 and therefore have low output impedance. To match the connection to the characteristic impedance of the USB cable, series resistors must be connected to both USB + and USB -.

### 6.2.2 USB Pull-up Resistor

F2M03 features an internal USB pull-up resistor. This pulls the USB\_DP pin weakly high when F2M03 is ready to enumerate. It signals to the PC that it is a full-speed (12Mbit/s) USB device.

The USB internal pull-up is implemented as a current source, and is compliant with 7.1.5 of the USB specification v1.1. The internal pull-up pulls USB DP high to at least 2.8V when loaded with a 15kΩ-5% pull-down resistor (in the hub/host) (when VDD=3.1V). This presents a the venin resistance to the host of at least 900Ω. Alternatively, an external 1.5kΩ pull-up resistor can be placed between a PIO line and D+ on the USB cable. The default setting for the HCI-firmware uses the internal pull-up resistor.

### 6.2.3 Power Supply

The minimum output high voltage for USB data lines is 2.8V. To safely meet the USB specification, the voltage on terminals must be an absolute minimum of 3.1V. Free2move recommends 3.3V for optimal USB signal quality.

### 6.2.4 Self-Powered Mode

In self-powered mode, the circuit is powered from its own power supply and not from the VBUS (5V) line of the USB cable (Default setting for the HCI-firmware). This is the easier mode for which to design for, as the design is not limited by the power that can be drawn from the USB hub or root port. However, it requires that VBUS be connected to F2M03 via a resistor network (Rvb1 and Rvb2), so F2M03 can detect when VBUS is powered up. F2M03 will not pull USB + high when VBUS is off.

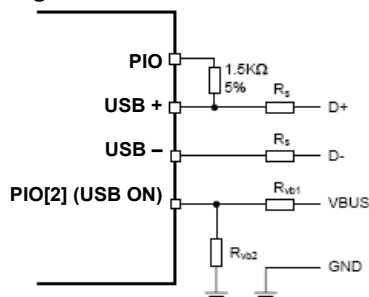

Connections to F2M03 for Self-Powered Mode

The terminal marked USB ON is default PIO[2] in the standard HCI-firmware.

### 6.2.5 Bus-Powered Mode

In bus-powered mode the application circuit draws its current from the 5V VBUS supply on the USB cable. F2M03 negotiates with the PC during the USB enumeration stage about power consumption. Bus-Powered mode is not supported in the default firmware of the HCI-firmware

When selecting a regulator, be aware that VBUS may go as low as 4.4V. The inrush current (when charging reservoir and supply decoupling capacitors) is limited by the USB specification (see USB 1.1 specification, section 7.2.4.1). Some applications may require soft-start circuitry to limit inrush current if more than 10μF is present between VBUS and GND.

The 5V VBUS line emerging from a PC is often electrically noisy. Regulation down to e.g. VDD=3.3V should include careful filtering of the 5V line to attenuate noise that is above the voltage regulator's bandwidth. Excessive noise on the VDD supply pins of F2M03 may result in reduced receive sensitivity and a distorted transmit signal. Recommended voltage regulator for the F2M03 is presented in section [6.7](#).

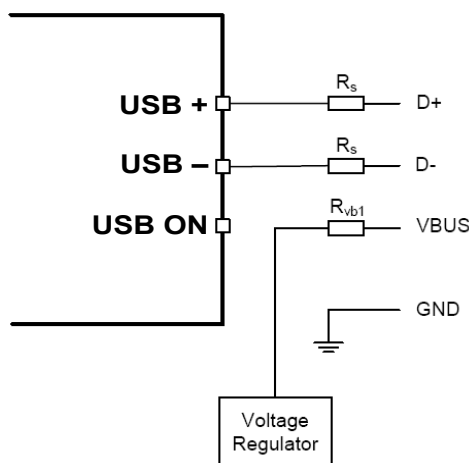

Connections to F2M03 for Bus-Powered Mode

Identifier	Value	Function
R <sub>s</sub>	27Ω nominal	Impedance matching to USB cable
R <sub>vb1</sub>	22kΩ-5%	VBUS ON sense divider
R <sub>vb2</sub>	47kΩ -5%	VBUS ON sense divider

USB Interface Component Values

**Note:**

USB ON is shared with F2M03's PIO terminals.

**6.2.6 Suspend Current**

USB devices that run off VBUS must be able to enter a suspended state, whereby they consume less than 0.5mA from VBUS. The voltage regulator circuit itself should draw only a small quiescent current (typically less than 100µA) to ensure adherence to the suspend-current requirement of the USB specification. This is not normally a problem with modern regulators. The entire circuit must be able to enter the suspend mode.

**6.2.7 Detach and Wake\_Up Signaling**

F2M03 can provide out-of-band signaling to a host controller by using the dedicated control lines called USB\_DETACH and USB\_WAKE\_UP. These are outside the USB specification (no wires exist for them inside the USB cable), but can be useful when embedding F2M03 into a circuit where no external USB is visible to the user. Both control lines are shared with PIO pins and can be assigned to any PIO pin by firmware settings (contact Free2move)

USB\_DETACH, is an input which, when asserted high, causes F2M03 to put USB- and USB+ in a high-impedance state and turns off the pull-up resistor on USB+. This detaches the device from the bus and is logically equivalent to unplugging the device. When USB\_DETACH is taken low, F2M03 will connect back to USB and await enumeration by the USB host.

USB\_WAKE\_UP, is an active high output (used only when USB\_DETACH is active) to wake up the host and allow USB communication to recommence. It replaces the function of the software USB WAKE\_UP message (which runs over the USB cable proper), and cannot be sent while F2M03 is effectively disconnected from the bus.

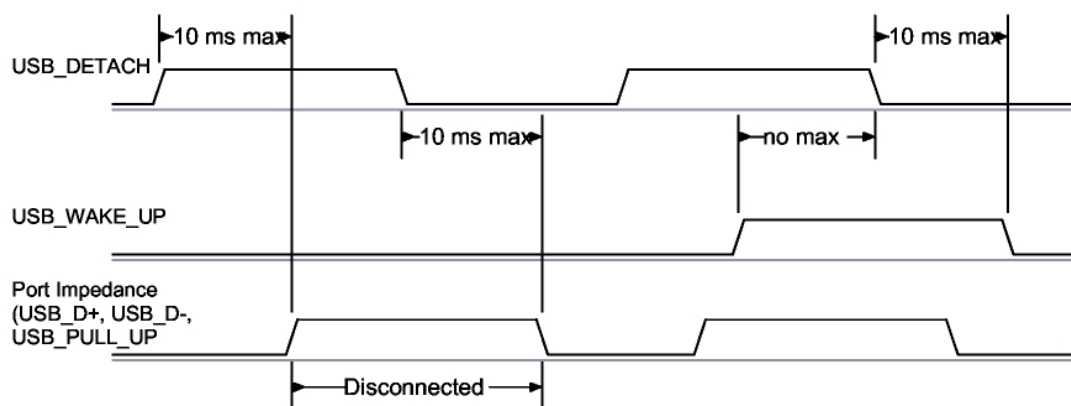

USB\_DETACH and USB\_WAKE\_UP Signal

### 6.2.8 USB Driver

A USB Bluetooth® device driver is required to provide a software interface between F2M03 and Bluetooth® applications running on the host. Free2move don't supply this driver.

### 6.2.9 USB 1.1 Compliance

The Bluetooth® chip on the F2M03 is qualified to the USB specification v1.1, details of which are available from <http://www.usb.org>. The specification contains valuable information on aspects such as PCB track impedance, supply inrush current and product labeling.

Although F2M03's Bluetooth® module meets the USB specification, Free2move cannot guarantee that an application circuit designed around the chip is USB compliant. The choice of application circuit, component choice and PCB layout all affect USB signal quality and electrical characteristics. The information in this document is intended as a guide and should be read in association with the USB specification. Independent USB qualification must be sought before an application is deemed USB compliant and can bear the USB logo. Such qualification can be obtained from a USB plugfest or from an independent USB test house.

Terminals USB+ and USB- adhere to the USB specification v2.0 (Chapter 7) electrical requirements. For ac and dc specifications for terminals USB\_DETACH, USB\_WAKE\_UP, USB\_PULL\_UP and USB\_ON, refer to section PIO specification.

### 6.2.10 2.0 Compatibility

F2M03 is compatible with USB specification v2.0 host controllers; under these circumstances the two ends agree the mutually acceptable rate of 12Mbits/s according to the USB v2.0 specification.

## 6.3 Serial Peripheral Interface

F2M03 is a slave device that uses terminals SPI\_MOSI, SPI\_MISO, SPI\_CLK and SPI\_CSB. This interface is used for program emulation/debug and IC test. It is also the means by which the F2M03 flash may be programmed, before any 'boot' program is loaded.

Note:

The SPI signals should be routed out from the module if you need to upgrade the firmware on the module in the future when the module is already soldered. It is highly recommended to route out the SPI-signals of the module for software upgrade of the firmware!

**Note:**

The designer should be aware that no security protection is built into the hardware or firmware associated with this port, so the terminals should not be permanently connected in a PC application. This interface is not a user interface and only used for initial download and configuration of the firmware for the module.

## 6.4 I<sup>2</sup>C Interface

PIO[8:6] can be used to form a master I2C interface. The interface is formed using software to drive these lines. Therefore, it is suited only to relatively slow functions such as driving a dot matrix liquid crystal display (LCD), keyboard scanner or EEPROM.

### Notes:

The I<sup>2</sup>C interface is controlled by firmware specific settings. Please see specific firmware datasheet for information PIO lines need to be pulled-up through 2.2k resistors.

PIO[7:6] dual functions, UART bypass and EEPROM support, therefore, devices using an EEPROM cannot support UART bypass mode.

For connection to EEPROMs, contact Free2move for information about devices that are currently supported.

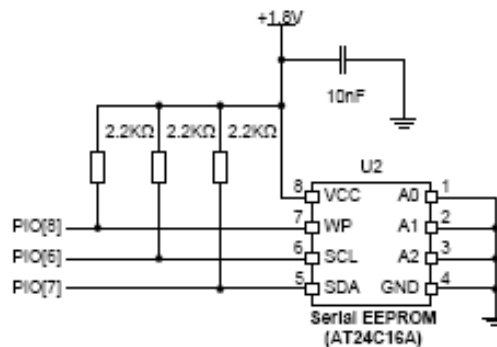

Example EEPROM Connection

## 6.5 PCM

Pulse Code Modulation (PCM) is the standard method used to digitise audio (particular voice) for transmission over digital communication channels. Through its PCM interface, F2M03 has hardware support for continual transmission and reception of PCM data, thus reducing processor overhead for wireless headset and other audio applications. F2M03 offers a bi-directional digital audio interface that routes directly into the baseband layer of the on-chip firmware. It does not pass through the HCI protocol layer.

Hardware on F2M03 allows the data to be sent to and received from a SCO connection. Up to three SCO connections can be supported by the PCM interface at any one time<sup>(1)</sup>

F2M03 can operate as the PCM interface Master generating an output clock of 128, 256 or 512kHz. When configured as PCM interface slave it can operate with an input clock up to 2048kHz. F2M03 is compatible with a variety of clock formats, including Long Frame Sync, Short Frame Sync and GCI timing environments.

It supports 13 or 16-bit linear, 8-bit  $\mu$ -law or A-law companded sample formats at 8ksamples/s and can receive and transmit on any selection of three of the first four slots following PCM\_SYNC. The PCM configuration options are enabled by firmware settings (contact Free2move).

F2M03 interfaces directly to PCM audio devices includes the following:

Qualcomm MSM 3000 series and MSM 5000 series CDMA baseband devices

- OKI MSM7705 four channel A-law and  $\mu$ -law CODEC
- Motorola MC145481 8-bit A-law and  $\mu$ -law CODEC
- Motorola MC145483 13-bit linear CODEC
- Winbond W681360R 13-bit linear CODEC
- STW 5093 and 5094 14-bit linear CODECs
- F2M03 is also compatible with the Motorola SSI™ interface

**Note:**

<sup>(1)</sup> Subject to firmware support, contact Free2move for current status.

### 6.5.1 PCM Interface Master/Slave

When configured as the Master of the PCM interface, F2M03 generates PCM\_CLK and PCM\_SYNC.

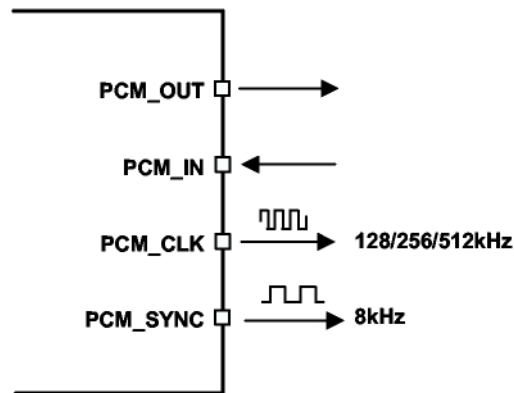

F2M03 as PCM Interface Master

When configured as the Slave of the PCM interface, F2M03 accepts PCM\_CLK rates up to 2048kHz

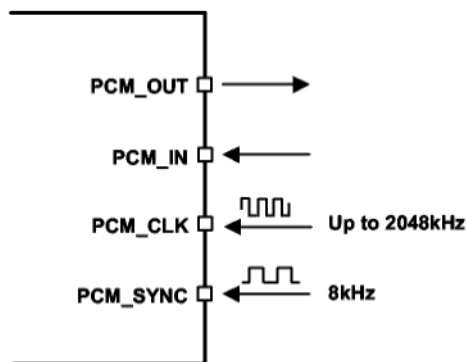

F2M03 as PCM Interface Master

### 6.5.2 Long Frame Sync

Long Frame Sync is the name given to a clocking format that controls the transfer of PCM data words or samples. In Long Frame Sync, the rising edge of PCM\_SYNC indicates the start of the PCM word. When F2M03 is configured as PCM Master, generating PCM\_SYNC and PCM\_CLK, then PCM\_SYNC is 8-bits long. When F2M03 is configured as PCM Slave, PCM\_SYNC may be from two consecutive falling edges of PCM\_CLK to half the PCM\_SYNC rate (i.e., 62.5µs) long.

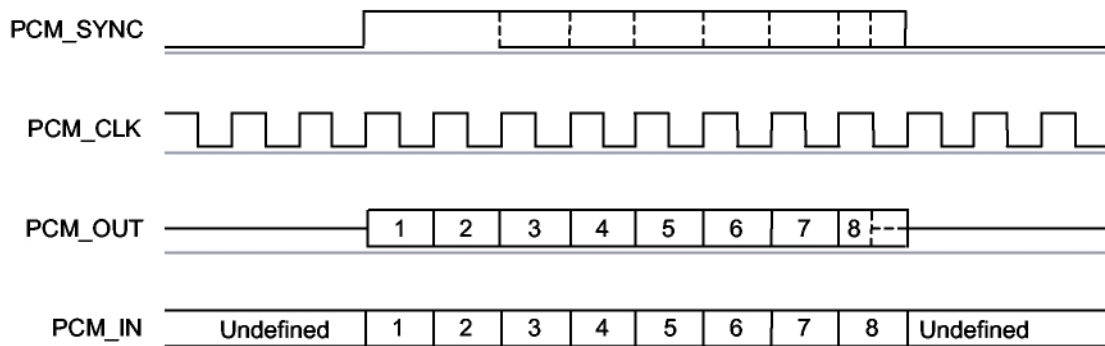

Long Frame Sync (Shown with 8-bit Companded Sample)

F2M03 samples PCM\_IN on the falling edge of PCM\_CLK and transmits PCM\_OUT on the rising edge. PCM\_OUT may be configured to be high impedance on the falling edge of PCM\_CLK in the LSB position or on the rising edge.

### 6.5.3 Short Frame Sync

In Short Frame Sync the falling edge of PCM\_SYNC indicates the start of the PCM word. PCM\_SYNC is always one clock cycle long.

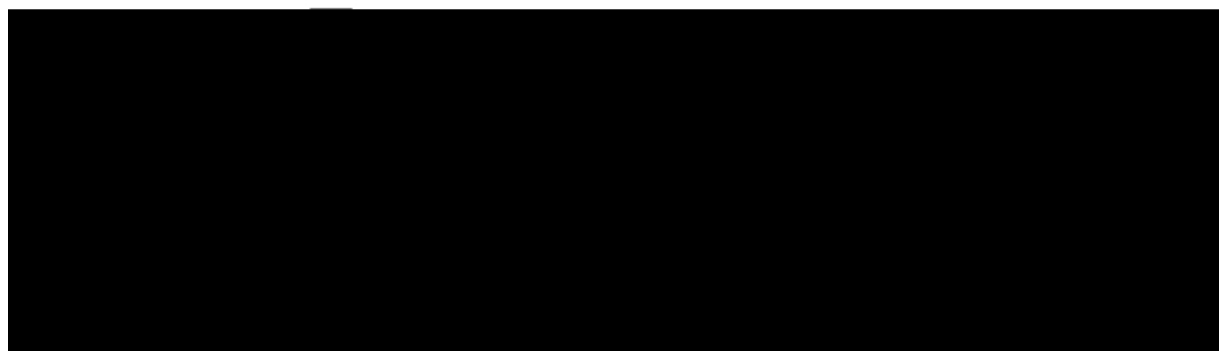

Short Frame Sync (Shown with 16-bit Sample)

As with Long Frame Sync, F2M03 samples PCM\_IN on the falling edge of PCM\_CLK and transmits PCM\_OUT on the rising edge. PCM\_OUT may be configured to be high impedance on the falling edge of PCM\_CLK in the LSB position or on the rising edge.

### 6.5.4 Multi-Slot Operation

More than one SCO connection over the PCM interface is supported using multiple slots. Up to three SCO connections can be carried over any of the first four slots.

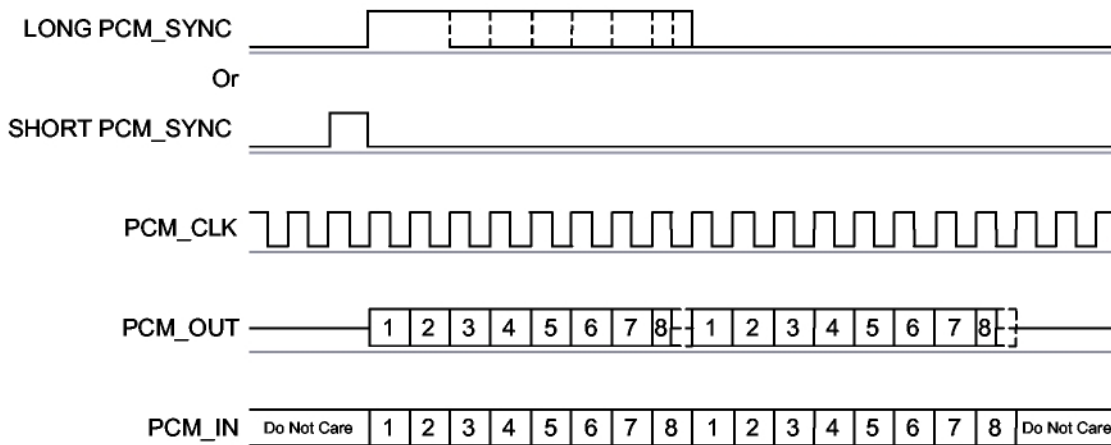

Multi-slot Operation with Two Slots and 8-bit Companded Samples

### 6.5.5 GCI Interface

F2M03 is compatible with the General Circuit Interface, a standard synchronous 2B+D ISDN timing interface. The two 64Kbps B channels can be accessed when this mode is configured. In the GCI interface two clock cycles are required for each bit of the voice sample. The voice sample format is 8-bit companded. As for the standard PCM interface up to 3 SCO connections can be carried over the first four slots.

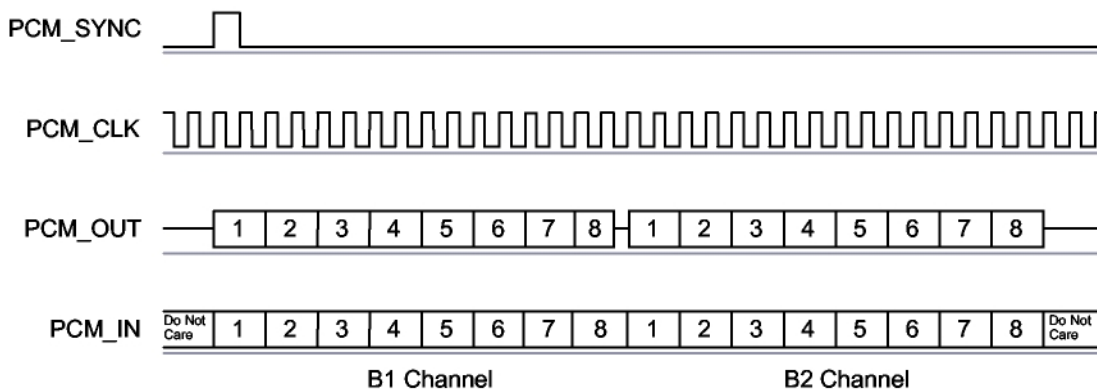

GCI Interface

The start of frame is indicated by PCM SYNC and runs at 8kHz. With F2M03 in Slave mode, the frequency of PCMCLK can be up to PCM\_SYNC. In order to configure the PCM interface to work in GCI mode it is necessary to have the correct firmware support (contact Free2move)

### 6.5.6 Slots and Sample Formats

F2M03 can receive and transmit on any selection of the first four slots following each sync pulse. Slot durations can be either 8 or 16 clock cycles. Durations of 8 clock cycles may only be used with 8-bit sample formats. Durations of 16 clocks may be used with 8, 13 or 16-bit sample formats.

F2M03 supports 13-bit linear, 16-bit linear and 8-bit  $\mu$ -law or A-law sample formats. The sample rate is 8ksamples/s. The bit order may be little or big endian. When 16-bit slots are used, the 3 or 8 unused bits in each slot may be filled with sign extension, padded with zeros or a programmable 3-bit audio attenuation compatible with some Motorola CODECs.

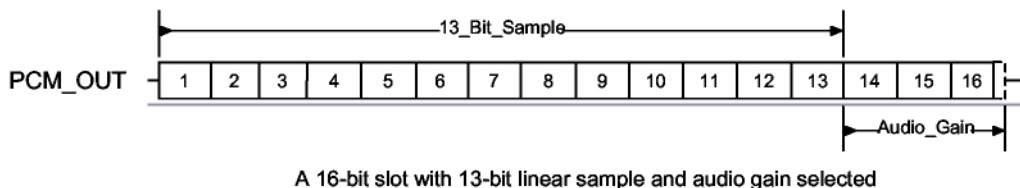
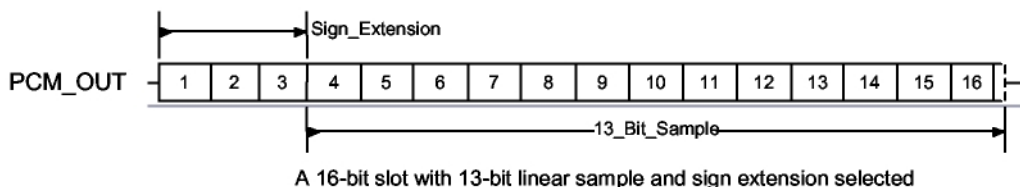
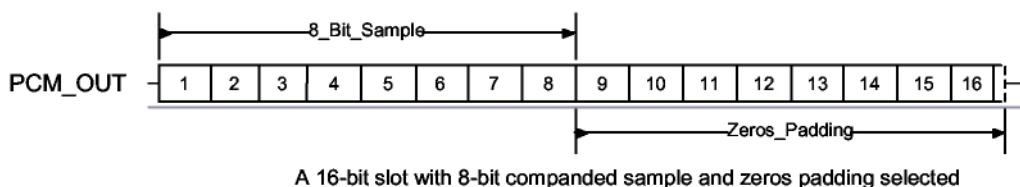
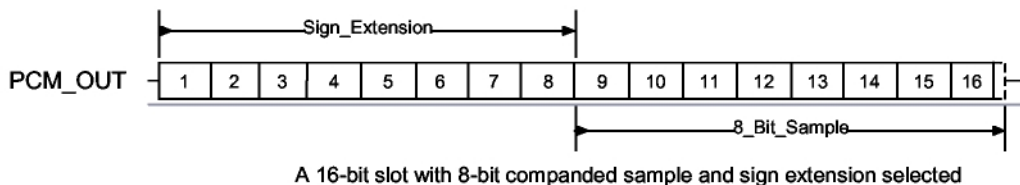

### 6.5.7 Additional Features

F2M03 has a mute facility that forces PCM\_OUT to be 0. In Master mode, PCM\_SYNC may also be forced to 0 while keeping PCM\_CLK running (which some CODECS use to control power-down)

6.5.8 PCM Timing Information

PCM Master Timing

Symbol	Parameter	Min <sup>(1)</sup>	Typ	Max <sup>(2)</sup>	Unit
$f_{mclk}$	PCMCLK frequency	-	128 256 512	-	kHz
-	PCM_SYNC frequency	-	8	-	kHz
$t_{mclkh}^{(1)}$	PCM_CLK high	980	-	-	ns
$t_{mclkl}^{(1)}$	PCM_CLK low	730	-	-	ns
$t_{dmclksynch}$	Delay time from PCM_CLK high to PCM_SYNC high	-	-	20	ns
$t_{dmclkpout}$	Delay time from PCM_CLK high to valid PCM_OUT	-	-	20	ns
$t_{dmclksyncl}$	Delay time from PCM_CLK low to PCM_SYNC low (Long Frame Sync only)	-	-	20	ns
$t_{dmclksyncl}$	Delay time from PCM_CLK high to PCM_SYNC low	-	-	20	ns
$t_{dmclklpoutz}$	Delay time from PCM_CLK low to PCMOUT high impedance	-	-	20	ns
$t_{dmclkhoutz}$	Delay time from PCM_CLK high to PCMOUT high impedance	-	-	20	ns
$t_{supinckl}$	Set-up time for PCM_IN valid to PCM_CLK low	30	-	-	ns
$t_{hpinckl}$	Hold time for PCM_CLK low to PCM_IN invalid	30	-	-	ns
$t_r$	Edge rise time ( $C_l = 50$ pf, 10-90 %)	-	-	15	ns
$t_f$	Edge fall time ( $C_l = 50$ pf, 10-90 %)	-	-	15	ns

Note:

<sup>(1)</sup> Assumes normal system clock operation. Figures will vary during low power modes, when system clock speeds are reduced.

<sup>(2)</sup> Valid for temperatures between -40°C and +85°C

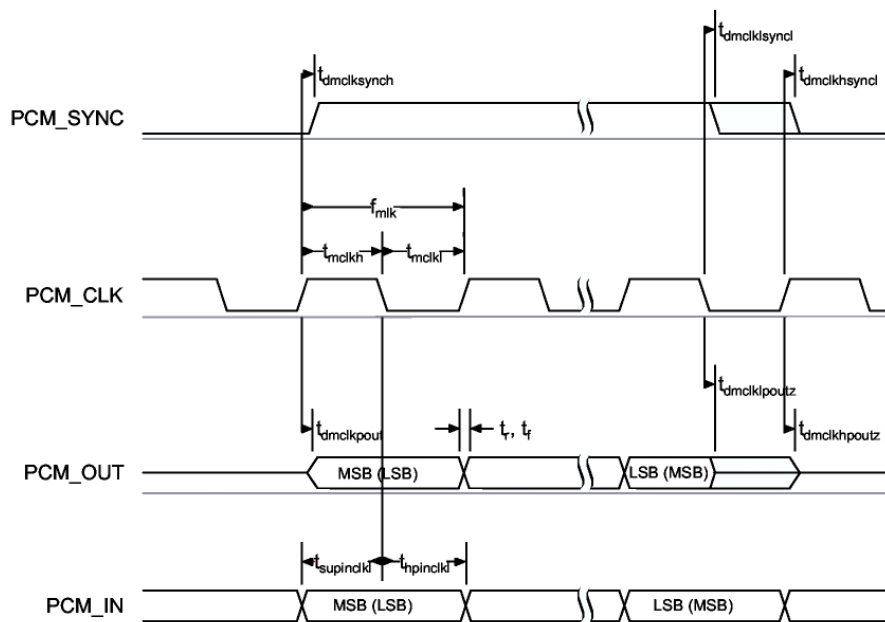

PCM Master Timing

**PCM Slave Timing**

Symbol	Parameter	Min <sup>(1)</sup>	Typ	Max <sup>(1)</sup>	Unit
f <sub>sclk</sub>	PCM clock frequency (Slave mode: input)	64	-	2048	kHz
f <sub>sclk</sub>	PCM clock frequency (GCI mode)	128	-	4096	kHz
t <sub>sckl</sub>	PCM_CLK low time	200	-	-	ns
t <sub>sckh</sub>	PCM_CLK high time	200	-	-	ns
t <sub>hscclksynch</sub>	Hold time from PCM_CLK low to PCM_SYNC high	30	-	-	ns
t <sub>susclksynch</sub>	Set-up time for PCM_SYNC high to PCM_CLK low	30	-	-	ns
t <sub>dpout</sub>	Delay time from PCM_SYNC or PCM_CLK whichever is later, to valid PCM_OUT data (Long Frame Sync only)	-	-	20	ns
t <sub>dsclkhout</sub>	Delay time from CLK high to PCM_OUT valid data	-	-	20	ns
t <sub>dpoutz</sub>	Delay time from PCM_SYNC or PCM_CLK low, whichever is later, to PCM_OUT data line high impedance	-	-	20	ns
t <sub>supinsclk</sub>	Set-up time for PCM_IN valid to CLK low	30	-	-	ns
t <sub>hpinsclk</sub>	Hold time for PCM_CLK low to PCM_IN invalid	30	-	-	ns
t <sub>r</sub>	Edge rise time (Cl = 50 pF, 10-90 %)	-	-	15	ns
T <sub>f</sub>	Edge fall time (Cl = 50 pF, 10-90 %)	-	-	15	ns

Note:

<sup>(1)</sup> Valid for temperatures between -40°C and +105°C

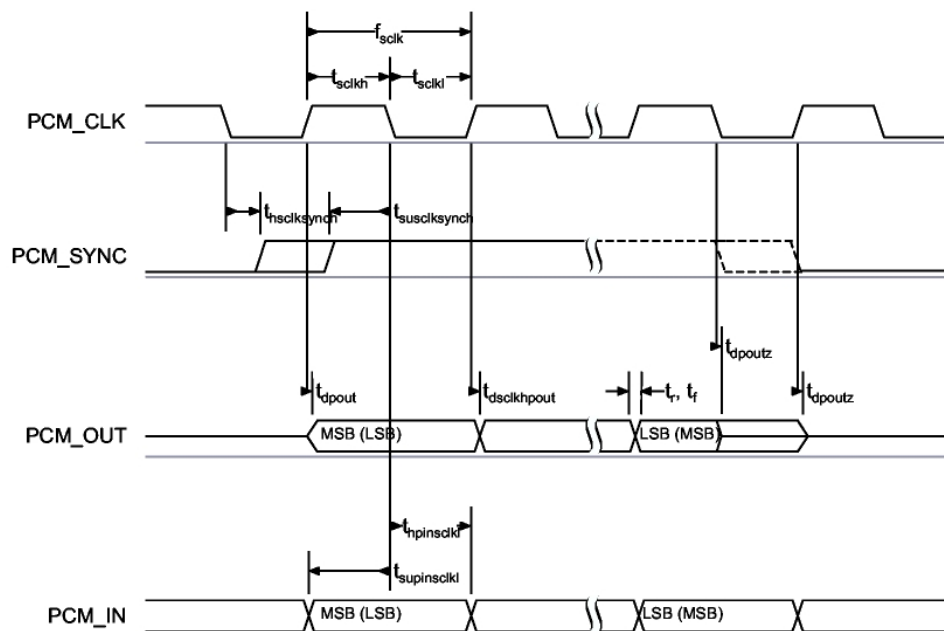

PCM slave timing

## 6.6 PIOs

The F2M03GLA have 10 programmable general-purpose I/O ports PIO[11:2] and two analog I/O ports AIO[1:0]. PIO lines can be configured through software to have either weak or strong pull-ups or pull-downs.

All PIO lines are configured as inputs with weak pull-downs at reset.

AIO[1:0] functions available via these pins include an 8-bit ADC but can also be used as general-purpose I/O lines. Typically the AIO[0] is used for battery voltage measurement. The voltage range for AIO[1:0] is constrained by the internal analogue supply voltage which is 1.8V.

**Note:**

**The PIO and AIO lines are controlled by firmware specific settings. Please see specific firmware datasheet for information about the PIOs used!**

### 6.6.1 General-purpose I/O lines

**PIO[2]**

Programmable I/O terminal.

**PIO[3]**

Programmable I/O terminal.

**PIO[4]/ BT\_Priority/Ch\_Clk**

Programmable input/output line or Optionally BT\_Priority/Ch\_Clk output for co-existence signalling

**PIO[5]/BT\_Active**

Programmable input/output line or Optionally BT\_Active output for co-existence signalling

**PIO[6]/WLAN\_Active/Ch\_Data**

Programmable input/output line or Optionally WLAN\_Active/Ch\_Data input for co-existence signalling

**PIO[7]**

Programmable I/O terminal.

**PIO[8]**

Programmable I/O terminal.

**PIO[9]**

Programmable I/O terminal.

**PIO[10]**

Programmable I/O terminal.

**PIO[11]**

Programmable I/O terminal.

### 6.6.2 Analog I/O lines

**AIO[0]**

Programmable input/output line also possible to use as digital I/O

**AIO[1]**

Programmable input/output line also possible to use as digital I/O

## 6.7 Power supply

The power supply for the F2M03GLA should be chosen carefully. Bad power supply can reduce the performance and may damage the module. Please use the recommended voltage regulator or consult Free2move if using another regulator. It is also essential to use a proper reset circuit to the module for correct operation.

### 6.7.1 Voltage regulator

The F2M03GLA has one power supply, +VCC.

The voltage supplied should have low noise, less than 10mV rms between 0 and 10MHz. The transient response of the regulator is also important. At the start of a Bluetooth® packet, power consumption will jump to high levels. The regulator should have a response time of 20µs or less; it is essential that the power rail recovers quickly.

Recommended voltage regulator:

XC6209B332MR from Torex or TPS73633DBVTG4 from Texas Instrument

### 6.7.2 Reset

The F2M03GLA has an active low reset (pin nr: 30). The reset pin MUST be connected to either a reset-circuit (voltage monitor) such as the TC1270ASVRCTR, MAX811S, DS1818 or using an I/O from a microcontroller. Reset cannot be done with a R-C network. It is recommended to use one of the reset circuits mentioned above. Special considerations must be taken when using an I/O from a microcontroller; a pull-down resistor (1.8kΩ) must be placed on the I/O-line.

It is recommended that RESET is applied for a period greater than 5ms.

At reset the digital I/O pins are set to inputs for bi-directional pins and outputs are tristated. The PIOs have weak pull-downs.

## 7 Application information

### 7.1 Recommended land pattern

F2M03GLA

All dimensions are in [mm]

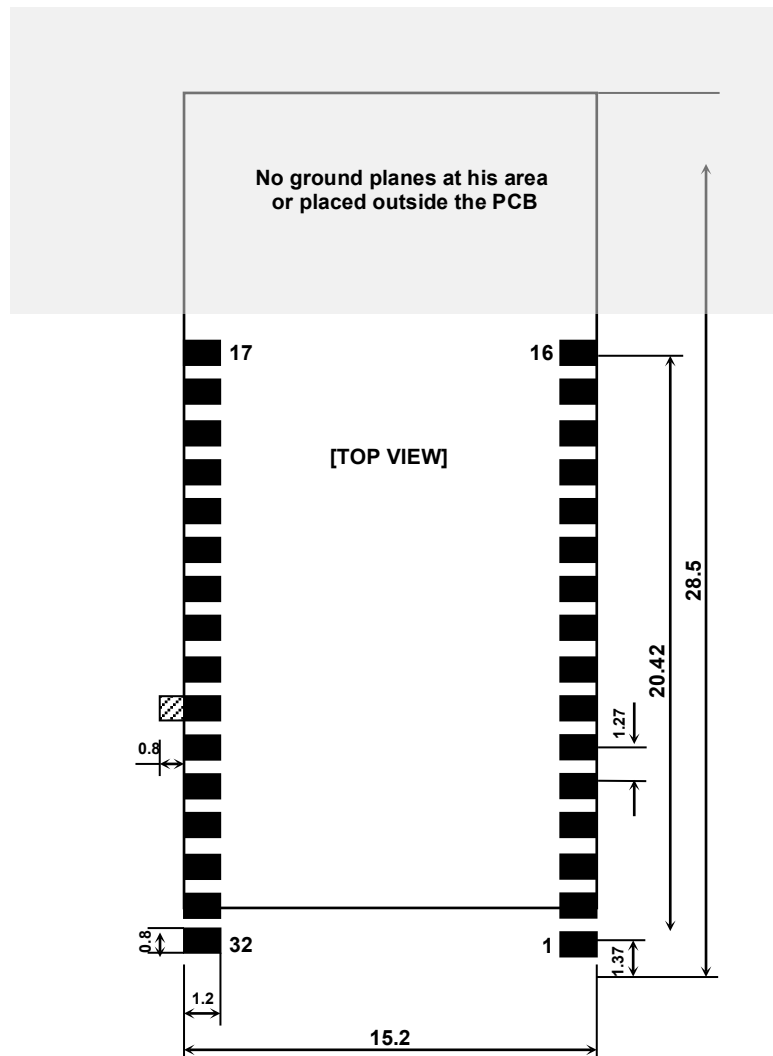

- Solder pad
- ▨ Recommended extended pad for manual soldering
- Restricted area for ground planes or other components

- Pad size: 0.8x1.2mm,
- Solder mask opening 0.9x1.3mm
- Pitch: 1.27mm (50mil)

## 7.2 Layout guidelines

The module uses bottom pads for soldering optimized for an automatic solder line. It is also possible to solder the module manually by using hot air soldering. For manual soldering solder pads may in some situation be made slightly larger to allow easier heating process.

To achieve good RF performance it is recommended to place ground plane(s) beneath the module but not under the antenna. The ground planes should be connected with vias surrounding the module. Except from the ground plane it is preferable that there are as few components and other material as possible nearby the antenna. Free air is the best surrounding for the antenna.

All GND pads must be connected directly to a flooded ground-plane. If more then one ground layer is used then make a good connection between them using many via holes. +VCC should be connected to the voltage regulator using a wide trace.

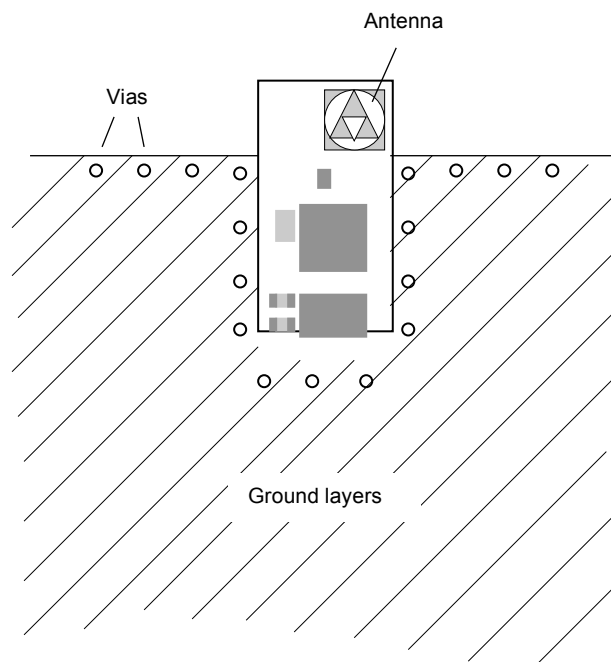

F2M03GLA

### 7.3 Typical application schematic

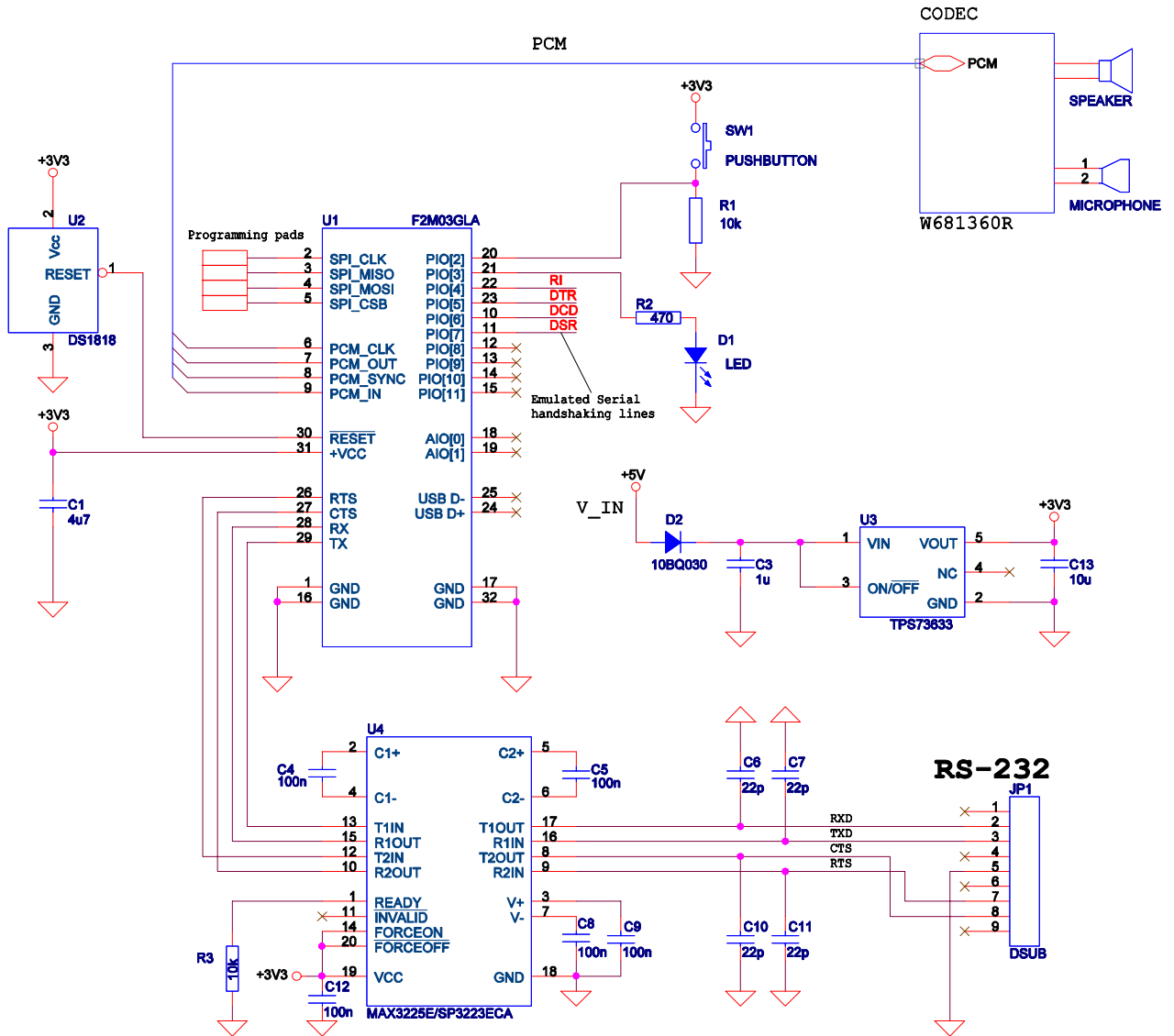

Typical application schematic for F2M03GLA when using the Wireless UART firmware

## 8 Package information

### F2M03GLA

Physical size [mm]:

Length: 28.5

Width: 15.2

Height: 2.1

**Weight:** 1.2g

## 9 Certifications

### 9.1 Bluetooth®

F2M03GLA has passed the Bluetooth® Qualification/Certification process as specified within the Bluetooth® Specifications and as required within the PRD 2.0.

**QDID: B012541**

### 9.2 CE

F2M03GLA complies with the requirements of R&TTE Directive 1999/5/CE, the European Community Directive 73/23/EEC and 93/68/EEC.

- EN 300 328
- EN 301 489-1/-17
- EN 60950

### 9.3 FCC

#### FCC-B Radio Frequency Interference Statement

This device has been tested and found to comply with the limits for a Class-B digital device, pursuant to part 15 of the FCC rules. These limits are designed to provide reasonable protection against harmful interference when the equipment is operated in commercial environment. This equipment generates, uses and can radiate radio frequency energy and, if not installed and used according with the instruction manual, may cause harmful interference to radio communication. Operation of this equipment in a residential area is likely to cause harmful interference, in which case the user will be required to correct the interference at his own expense.

#### Notice 1

The changes or modifications not expressly approved by the party responsible for the compliance could void the user's authority to operate the equipment.

#### Notice 2

Shielded interface cables and A.C. power cord, if any, must be used in order to comply with the emission limits.

#### Notice 3

This modular transmitter uses an electronic display of the FCC identification number, the information must be readily accessible on the device in which it is installed.

The FCC ID can be read from the UART of the device.

The FCC ID will be displayed in the Windows Configuration Program.

#### **FCC ID R47F2M03GL**

This device complies with part 15 of the FCC Rules. Operation is subject to the following two conditions: (1) This device may not cause harmful interference, and (2) This device must accept any interference received, including interference that may cause undesired operation.

If the module is installed inside another device, then the outside of the device into which the module is installed must display a label referring to the enclosed module. This exterior label can use wording such as the following: “Contains FCC certified transmitter module(s).”

Any similar wording that expresses the same meaning may be used.

## 9.4 IC

This device complies with RSS-210 of the Industry Canada Rules. Operation is subject to the following two conditions: (1) This device may not cause harmful interference, and (2) this device must accept any interference received, including interference that may cause undesired operation.

### IMPORTANT NOTE:

#### Radiation Exposure Statement:

This equipment complies with IC radiation exposure limits set forth for an uncontrolled environment.

End users must follow the specific operating instructions for satisfying RF exposure compliance.

To maintain compliance with IC RF exposure compliance requirements, please follow operation instruction as documented in this manual.

This device has been designed to operate with an antenna having a maximum gain of 2 dBi.

Antenna having a higher gain is strictly prohibited per regulations of Industry Canada. The required antenna impedance is **50 ohms**.

## 10 RoHS Statement

F2M03GLA meet the requirements of Directive 2002/95/EC of the European Parliament and of the Council on the Restriction of Hazardous Substance (RoHS). The module is assembled solely using RoHS compliant components.

## 11 REACH Statement

F2M03GLA meets the requirements of Substances of Very High Concern (SVHC) in accordance with list published by European Chemicals Agency (ECHA) on 2008 October 28, regarding Regulation (EC) No 1907/2006, by showing a concentration of all SVHC compounds < 0.1%.

## 12 Tape and Reel information

### 12.1 Package Tape dimensions

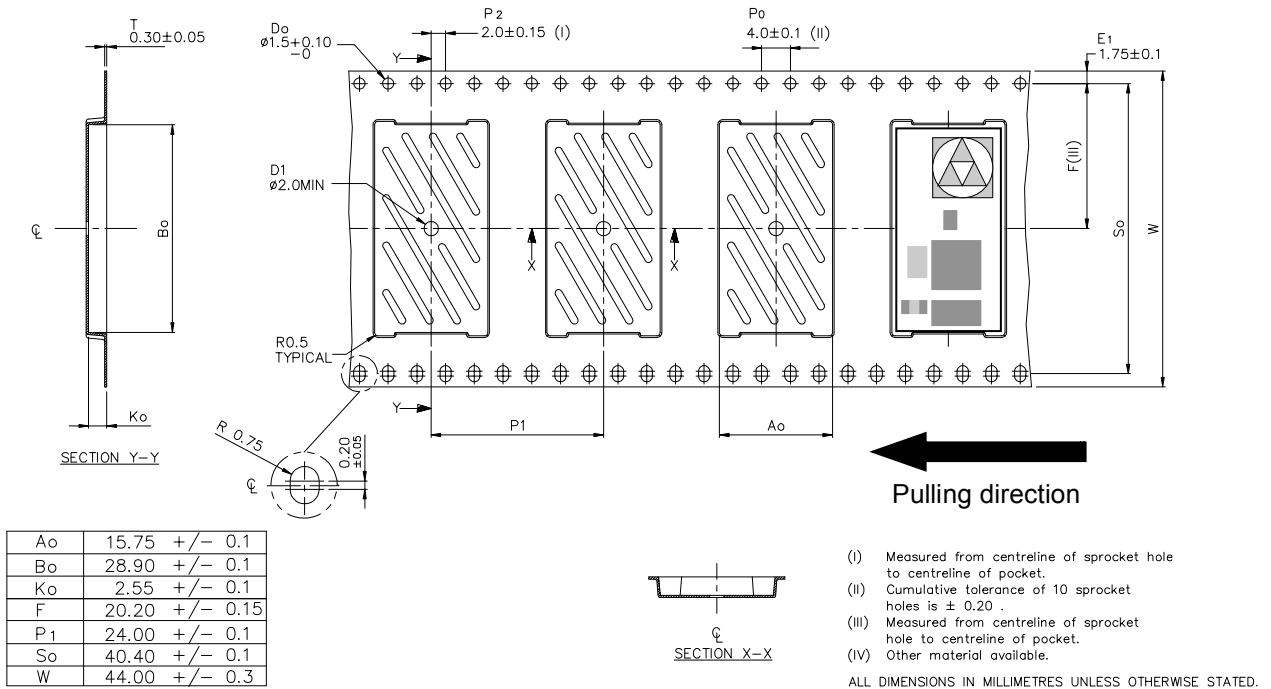

### 12.2 Reel dimensions

A	330.0 max
B	1.5 min
C	13.0±0.2
D	20.2 min
N	100.0
W1	44.4 +2.0 -0.0
W2	50.4 max

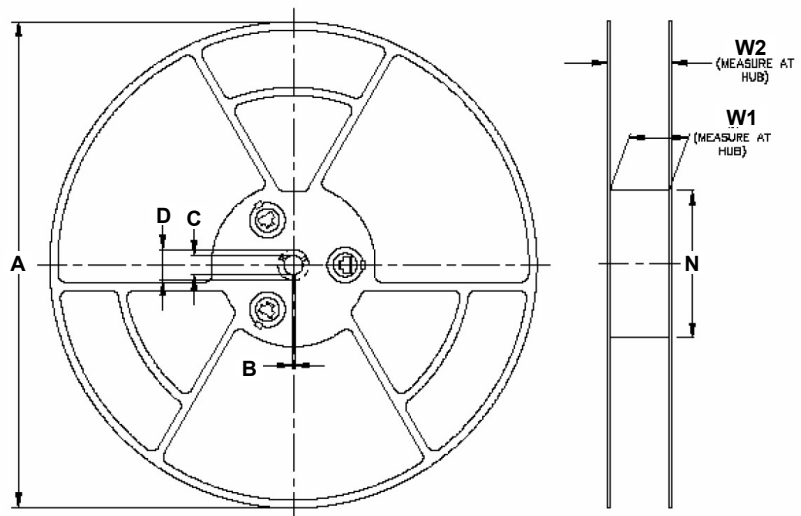

## 13 Ordering information

The F2M03GLA is available for delivery in volumes.

Part nr:	Description
F2M03GLA-S01	Low power Bluetooth® module with antenna and Wireless UART firmware v4. (SPP)
F2M03GLA-S04	Low power Bluetooth® module with antenna and HCI firmware (USB-interface, Self-powered)

Please use our website: [www.free2move.se](http://www.free2move.se) for more information about local distributors and dealers.

## 14 Document history

Date	Revision	Reason for Change
2009-04	E	Added REACH conformance information in chapter 11.
2009-03	D	Added IC certification conformance information in chapter 9.4.
2007-06	C	Added certification, tape & reel, power consumption information and minor other changes in the document.
2007-01	B	Small technical changes of the document.
2006-11	A	Original Publication of this document.

# F2M03GLA Datasheet

Datasheet\_F2M03GLA\_rev\_e.pdf

**Last revision change**  
April 2009

## 15 Acronyms and definitions

Term:	Definition:
Bluetooth®	A set of technologies providing audio and data transfer over short-range radio
ACL	Asynchronous Connection-Less. A Bluetooth® data packet.
AC	Alternating Current
A-law	Audio encoding standard
API	Application Programming Interface
BCSP	BlueCore™ Serial Protocol
BER	Bit Error Rate. Used to measure the quality of a link
C/I	Carrier Over Interferer
CMOS	Complementary Metal Oxide Semiconductor
CODEC	Coder Decoder
CPU	Central Processing Unit
CQDDR	Channel Quality Driven Data Rate
CTS	Clear to Send
CVSD	Continuous Variable Slope Delta Modulation
DAC	Digital to Analogue Converter
dBm	Decibels relative to 1mW
DC	Direct Current
DFU	Device Firmware Upgrade
GCI	General Circuit Interface. Standard synchronous 2B+D ISDN timing interface
HCI	Host Controller Interface
Host	Application's microcontroller
Host Controller	Bluetooth® integrated chip
HV	Header Value
ISDN	Integrated Services Digital Network
ISM	Industrial, Scientific and Medical
ksamples/s	kilosamples per second
L2CAP	Logical Link Control and Adaptation Protocol (protocol layer)
LC	Link Controller
LSB	Least-Significant Bit
p-law	Encoding standard
MISO	Master In Serial Out
OHCI	Open Host Controller Interface
PA	Power Amplifier
PCB	Printed Circuit Board
PCM	Pulse Code Modulation. Refers to digital voice data
PIO	Parallel Input Output
RAM	Random Access Memory
RF	Radio Frequency
RFCOMM	Protocol layer providing serial port emulation over L2CAP
RISC	Reduced Instruction Set Computer
RSSI	Receive Signal Strength Indication
RTS	Ready To Send
RX	Receive or Receiver
SCO	Synchronous Connection-Oriented. Voice oriented Bluetooth® packet
SDP	Service Discovery Protocol
SIG	Special Interest Group
SPI	Serial Peripheral Interface
SPP	Serial Port Profile
TBD	To Be Defined
TX	Transmit or Transmitter
UART	Universal Asynchronous Receiver Transmitter
USB	Universal Serial Bus or Upper Side Band (depending on context)
VM	Virtual Machine
www	world wide web

## Contact information

For support questions please contact your local dealer

For other purposes use: [info@free2move.se](mailto:info@free2move.se)

Website: [www.free2move.se](http://www.free2move.se)



Local dealer/distributor









The information given herein includes text, drawings, illustrations and schematics that are believed to be reliable. However, Free2move makes no warranties as to its accuracy or completeness and disclaims any liability in connection with its use. Free2move will in no case be liable for any incidental, indirect or consequential damages arising out of sale, resale, use or misuse of the product. Users of Free2move products should make their own evaluation to determine the suitability of each such product for the specific application.

## Looking for pricing, stock, or lifecycle information?

Click below to explore more details on WIN SOURCE:

-  [View F2M03GLA-S01 on WIN SOURCE](#)
-  [Free2Move Information](#)

## Optimize Your Supply Chain with WIN SOURCE Solutions

-  Global Sourcing Solution
-  Obsolete Management
-  Cost Control Management
-  Shortage Management
-  Alternative Solution
-  Excess Inventory Management