



**THE DATASHEET OF  
F28M35H52C1RFPQ**



## F28M35x Concerto™ Microcontrollers

### 1 Device Overview

#### 1.1 Features

- Master Subsystem — ARM® Cortex®-M3
  - Up to 100 MHz
  - Embedded Memory
    - Up to 512KB of Flash (ECC)
    - Up to 32KB of RAM (ECC or Parity)
    - Up to 64KB of Shared RAM
    - 2KB of IPC Message RAM
  - Five Universal Asynchronous Receiver/Transmitters (UARTs)
  - Four Synchronous Serial Interfaces (SSIs) and a Serial Peripheral Interface (SPI)
  - Two Inter-integrated Circuits (I2Cs)
  - Universal Serial Bus On-the-Go (USB-OTG) + PHY
  - 10/100 ENET 1588 MII
  - Two Controller Area Network, D\_CAN, Modules (Pin-Bootable)
  - 32-Channel Micro Direct Memory Access (μDMA)
  - Dual Security Zones (128-Bit Password per Zone)
  - External Peripheral Interface (EPI)
  - Micro Cyclic Redundancy Check (μCRC) Module
  - Four General-Purpose Timers
  - Two Watchdog Timer Modules
  - Endianness: Little Endian
- Clocking
  - On-chip Crystal Oscillator and External Clock Input
  - Dynamic Phase-Locked Loop (PLL) Ratio Changes Supported
- 1.2-V Digital, 1.8-V Analog, 3.3-V I/O Design
- Interprocessor Communications (IPC)
  - 32 Handshaking Channels
  - Four Channels Generate IPC Interrupts
  - Can be Used to Coordinate Transfer of Data Through IPC Message RAMs
- Up to 74 Individually Programmable, Multiplexed General-Purpose Input/Output (GPIO) Pins
  - Glitch-free I/Os
- Control Subsystem — TMS320C28x 32-Bit CPU
  - Up to 150 MHz
  - C28x Core Hardware Built-in Self-Test
  - Embedded Memory
    - Up to 512KB of Flash (ECC)
    - Up to 36KB of RAM (ECC or Parity)
    - Up to 64KB of Shared RAM
    - 2KB of IPC Message RAM
  - IEEE-754 Single-Precision Floating-Point Unit (FPU)
  - Viterbi, Complex Math, CRC Unit (VCU)
  - Serial Communications Interface (SCI)
  - SPI
  - I2C
  - 6-Channel Direct Memory Access (DMA)
  - Nine Enhanced Pulse Width Modulator (ePWM) Modules
    - 18 Outputs (16 High-Resolution)
  - Six 32-Bit Enhanced Capture (eCAP) Modules
  - Three 32-Bit Enhanced Quadrature Encoder Pulse (eQEP) Modules
  - Multichannel Buffered Serial Port (McBSP)
  - EPI
  - One Security Zone (128-Bit Password)
  - Three 32-Bit Timers
  - Endianness: Little Endian
- Analog Subsystem
  - Dual 12-Bit Analog-to-Digital Converters (ADCs)
    - Up to 2.88 MSPS
    - Up to 20 Channels
    - Four Sample-and-Hold (S/H) Circuits
    - Up to Six Comparators With 10-Bit Digital-to-Analog Converter (DAC)
- Package
  - 144-Pin RFP PowerPAD™ Thermally Enhanced Thin Quad Flatpack (HTQFP)
- Temperature Options:
  - T: –40°C to 105°C Junction
  - S: –40°C to 125°C Junction
  - Q: –40°C to 125°C Free-Air (AEC Q100 Qualification for Automotive Applications)



## 1.2 Applications

- [Servo Drives](#)
- [High-End AC Inverters](#)
- [Industrial UPS](#)
- [Solar Inverters](#)
- [Electric Vehicle/Hybrid Electric Vehicle \(EV/HEV\) Chargers](#)
- [Power Line Communications](#)

## 1.3 Description

The Concerto family is a multicore system-on-chip microcontroller unit (MCU) with independent communication and real-time control subsystems. The F28M35x family of devices is the first series in the Concerto family.

The communications subsystem is based on the industry-standard 32-bit ARM Cortex-M3 CPU and features a wide variety of communication peripherals, including Ethernet 1588, USB OTG with PHY, Controller Area Network (CAN), UART, SSI, I2C, and an external interface.

The real-time control subsystem is based on TI's industry-leading proprietary 32-bit C28x floating-point CPU and features the most flexible and high-precision control peripherals, including ePWMs with fault protection, and encoders and captures—all as implemented by TI's TMS320C2000™ Piccolo™ and Delfino™ families. In addition, the C28-CPU has been enhanced with the addition of the VCU instruction accelerator that implements efficient Viterbi, Complex Arithmetic, 16-bit FFTs, and CRC algorithms.

A high-speed analog subsystem and supplementary RAM memory is shared, along with on-chip voltage regulation and redundant clocking circuitry. Safety considerations also include Error Correction Code (ECC), parity, and code secure memory, as well as documentation to assist with system-level industrial safety certification.

**Device Information<sup>(1)</sup>**

| PART NUMBER   | PACKAGE     | BODY SIZE         |
|---------------|-------------|-------------------|
| F28M35H52CRFP | HTQFP (144) | 20.0 mm x 20.0 mm |
| F28M35H22CRFP | HTQFP (144) | 20.0 mm x 20.0 mm |
| F28M35M52CRFP | HTQFP (144) | 20.0 mm x 20.0 mm |
| F28M35M20BRFP | HTQFP (144) | 20.0 mm x 20.0 mm |
| F28M35E20BRFP | HTQFP (144) | 20.0 mm x 20.0 mm |

(1) For more information on these devices, see [Mechanical, Packaging, and Orderable Information](#).

### 1.4 Functional Block Diagram

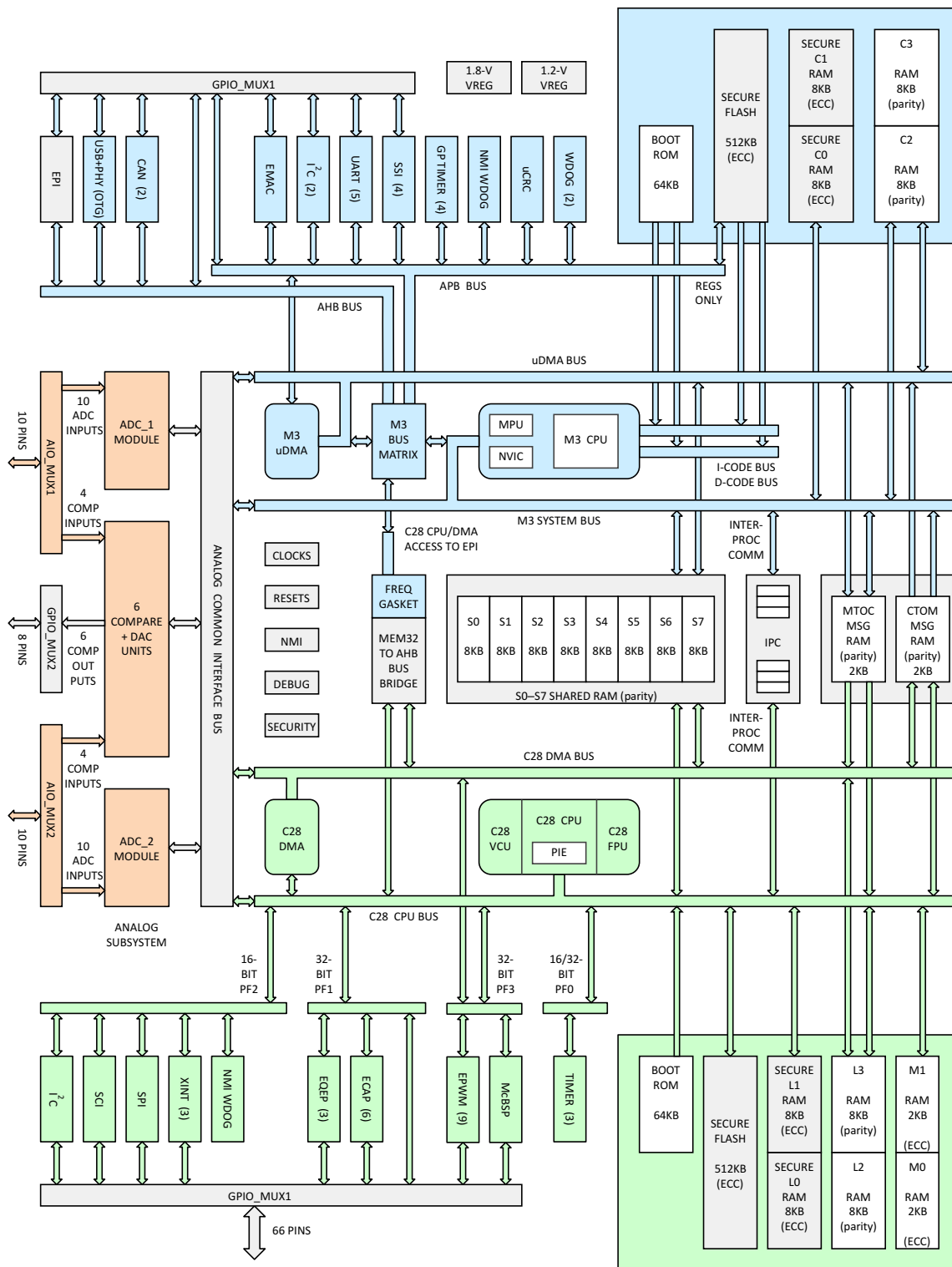

Copyright © 2017, Texas Instruments Incorporated

A. Some peripherals are not available on the F28M35Mx and F28M35Ex devices.

**Figure 1-1. Functional Block Diagram**

## Table of Contents

|          |  |                            |          |   |                            |
|----------|--|----------------------------|----------|---|----------------------------|
| <b>1</b> | <b>Device Overview</b>   | <b><a href="#">1</a></b>   | 6.5      | Analog Subsystem  | <a href="#">172</a>        |
| 1.1      | Features   | <a href="#">1</a>          | 6.6      | Master Subsystem NMIs   | <a href="#">175</a>        |
| 1.2      | Applications   | <a href="#">2</a>          | 6.7      | Control Subsystem NMIs  | <a href="#">175</a>        |
| 1.3      | Description  | <a href="#">2</a>          | 6.8      | Resets  | <a href="#">177</a>        |
| 1.4      | Functional Block Diagram                                       | <a href="#">3</a>          | 6.9      | Internal Voltage Regulation and Power-On-Reset<br>Functionality | <a href="#">182</a>        |
| <b>2</b> | <b>Revision History</b>  | <b><a href="#">5</a></b>   | 6.10     | Input Clocks and PLLs   | <a href="#">185</a>        |
| <b>3</b> | <b>Device Comparison</b>                                       | <b><a href="#">6</a></b>   | 6.11     | Master Subsystem Clocking                                       | <a href="#">195</a>        |
| 3.1      | Related Products   | <a href="#">9</a>          | 6.12     | Control Subsystem Clocking                                      | <a href="#">200</a>        |
| <b>4</b> | <b>Terminal Configuration and Functions</b>                    | <b><a href="#">10</a></b>  | 6.13     | Analog Subsystem Clocking                                       | <a href="#">203</a>        |
| 4.1      | Pin Diagram  | <a href="#">10</a>         | 6.14     | Shared Resources Clocking                                       | <a href="#">203</a>        |
| 4.2      | Signal Descriptions  | <a href="#">12</a>         | 6.15     | Loss of Input Clock (NMI Watchdog Function)                     | <a href="#">203</a>        |
| <b>5</b> | <b>Specifications</b>  | <b><a href="#">32</a></b>  | 6.16     | GPIOs and Other Pins  | <a href="#">205</a>        |
| 5.1      | Absolute Maximum Ratings                                       | <a href="#">32</a>         | 6.17     | Emulation/JTAG  | <a href="#">221</a>        |
| 5.2      | ESD Ratings – Automotive                                       | <a href="#">32</a>         | 6.18     | Code Security Module  | <a href="#">224</a>        |
| 5.3      | ESD Ratings – Commercial                                       | <a href="#">32</a>         | 6.19     | µCRC Module   | <a href="#">225</a>        |
| 5.4      | Recommended Operating Conditions                               | <a href="#">33</a>         | <b>7</b> | <b>Applications, Implementation, and Layout</b>                 | <b><a href="#">227</a></b> |
| 5.5      | Power Consumption Summary                                      | <a href="#">34</a>         | 7.1      | TI Design or Reference Design                                   | <a href="#">227</a>        |
| 5.6      | Electrical Characteristics                                     | <a href="#">39</a>         | <b>8</b> | <b>Device and Documentation Support</b>                         | <b><a href="#">228</a></b> |
| 5.7      | Thermal Resistance Characteristics for RFP<br>PowerPAD Package | <a href="#">40</a>         | 8.1      | Device and Development Support Tool<br>Nomenclature             | <a href="#">228</a>        |
| 5.8      | Thermal Design Considerations                                  | <a href="#">40</a>         | 8.2      | Tools and Software  | <a href="#">229</a>        |
| 5.9      | Timing and Switching Characteristics                           | <a href="#">41</a>         | 8.3      | Documentation Support   | <a href="#">230</a>        |
| 5.10     | Analog and Shared Peripherals                                  | <a href="#">60</a>         | 8.4      | Related Links   | <a href="#">231</a>        |
| 5.11     | Master Subsystem Peripherals                                   | <a href="#">96</a>         | 8.5      | Community Resources   | <a href="#">232</a>        |
| 5.12     | Control Subsystem Peripherals                                  | <a href="#">117</a>        | 8.6      | Trademarks  | <a href="#">232</a>        |
| <b>6</b> | <b>Detailed Description</b>                                    | <b><a href="#">150</a></b> | 8.7      | Electrostatic Discharge Caution                                 | <a href="#">232</a>        |
| 6.1      | Memory Maps  | <a href="#">151</a>        | 8.8      | Glossary  | <a href="#">232</a>        |
| 6.2      | Identification   | <a href="#">161</a>        | <b>9</b> | <b>Mechanical, Packaging, and Orderable<br/>Information</b>     | <b><a href="#">233</a></b> |
| 6.3      | Master Subsystem   | <a href="#">162</a>        | 9.1      | Packaging Information   | <a href="#">233</a>        |
| 6.4      | Control Subsystem  | <a href="#">168</a>        |          |   |                            |

## 2 Revision History

| Changes from June 8, 2015 to December 15, 2017 (from I Revision (June 2015) to J Revision)   | Page                |
|--|---------------------|
| • <b>Global:</b> Restructured document. ....   | <a href="#">1</a>   |
| • <b>Table 3-1</b> (Device Comparison): Changed "Flash (KB)" to "Flash (ECC) (KB)". Changed "RAM ECC (KB)" to "RAM (ECC) (KB)". Changed "RAM Parity (KB)" to "RAM (Parity) (KB)". Changed "IPC Message RAM Parity (KB)" to "IPC Message RAM (Parity) (KB)". Changed "Supplemental RAM Parity (KB)" to "Shared RAM (Parity) (KB)". .... | <a href="#">6</a>   |
| • <b>Section 3.1</b> (Related Products): Added section. ....   | <a href="#">9</a>   |
| • <b>Section 4.1</b> (Pin Diagram): Added NOTE about PowerPAD. ....  | <a href="#">11</a>  |
| • <b>Table 4-1</b> (Signal Descriptions): Changed BOOT_3 to Bmode_pin4. Changed BOOT_2 to Bmode_pin3. Changed BOOT_1 to Bmode_pin2. Changed BOOT_0 to Bmode_pin1. ....   | <a href="#">12</a>  |
| • <b>Section 5.2</b> (ESD Ratings – Automotive): Changed title from "ESD Ratings" to "ESD Ratings – Automotive". ....  | <a href="#">32</a>  |
| • <b>Section 5.2:</b> Updated table. ....  | <a href="#">32</a>  |
| • <b>Section 5.3</b> (ESD Ratings – Commercial): Added section. ....   | <a href="#">32</a>  |
| • <b>Section 5.9.1</b> (Power Sequencing): Added "(for analog pins, this value is 0.7 V above V <sub>DDA</sub> )" to "There is no power sequencing requirement needed ..." paragraph. ....   | <a href="#">41</a>  |
| • <b>Table 5-68</b> (High-Resolution PWM Characteristics at SYSCLKOUT = (60–150 MHz)): Updated footnote. ....  | <a href="#">120</a> |
| • <b>Section 5.12.6</b> (C28x Serial Peripheral Interface): Updated "Rising edge with phase delay" clocking scheme. ....   | <a href="#">132</a> |
| • <b>Section 5.12.6.2.1</b> (Master Mode Timing): Updated section. ....  | <a href="#">135</a> |
| • <b>Section 5.12.6.2.2</b> (Slave Mode Timing): Updated section. ....   | <a href="#">138</a> |
| • <b>Section 5.12.7.1.2</b> (McBSP as SPI Master or Slave Timing): Replaced "For all SPI slave modes ..." paragraphs with "For all SPI slave modes ..." table footnotes. ....  | <a href="#">146</a> |
| • <b>Table 5-83</b> (McBSP as SPI Master or Slave Timing Requirements (CLKSTP = 10b, CLKXP = 0)): Added "For all SPI slave modes ..." footnote. ....   | <a href="#">146</a> |
| • <b>Table 5-85</b> (McBSP as SPI Master or Slave Timing Requirements (CLKSTP = 11b, CLKXP = 0)): Added "For all SPI slave modes ..." footnote. ....   | <a href="#">147</a> |
| • <b>Table 5-87</b> (McBSP as SPI Master or Slave Timing Requirements (CLKSTP = 10b, CLKXP = 1)): Added "For all SPI slave modes ..." footnote. ....   | <a href="#">148</a> |
| • <b>Table 5-89</b> (McBSP as SPI Master or Slave Timing Requirements (CLKSTP = 11b, CLKXP = 1)): Added "For all SPI slave modes ..." footnote. ....   | <a href="#">149</a> |
| • <b>Table 6-8</b> (Master Subsystem Flash, ECC, OTP, Boot ROM): Updated address range 0068 0818 to 0070 00FF... ..  | <a href="#">156</a> |
| • <b>Section 6.2</b> (Identification): Added section. ....   | <a href="#">161</a> |
| • <b>Table 6-17</b> (Master Subsystem Boot Mode Selection): Changed BOOT_3 to Bmode_pin4. Changed BOOT_2 to Bmode_pin3. Changed BOOT_1 to Bmode_pin2. Changed BOOT_0 to Bmode_pin1. ....   | <a href="#">180</a> |
| • <b>Figure 6-10</b> (Cortex-M3 Clocks and Low-Power Modes): Updated "MAIN PLL" and "USB PLL" blocks. ....   | <a href="#">196</a> |
| • <b>Section 7</b> (Applications, Implementation, and Layout): Added section. ....   | <a href="#">227</a> |
| • <b>Section 8</b> (Device and Documentation Support): Restructured and updated section. ....  | <a href="#">228</a> |
| • <b>Section 8.2</b> (Tools and Software): Added "Models" section. ....  | <a href="#">229</a> |
| • <b>Section 8.3</b> (Documentation Support): Added <i>An Introduction to IBIS (I/O Buffer Information Specification) Modeling Application Note</i> . ....   | <a href="#">230</a> |

### 3 Device Comparison

Table 3-1 lists the features of the F28M35x devices.

**Table 3-1. Device Comparison**

| FEATURE                                 | TYPE <sup>(1)</sup> | H52C  | H22C  | M52C  | M22C  | M20B  | E20B  |
|---|---------------------|-------|-------|-------|-------|-------|-------|
| <b>Master Subsystem — ARM Cortex-M3</b> |                     |       |       |       |       |       |       |
| Speed (MHz) <sup>(2)</sup>              | –                   | 100   | 100   | 75    | 75    | 75    | 60    |
| Flash (ECC) (KB)                        | –                   | 512   | 256   | 512   | 256   | 256   | 256   |
| RAM (ECC) (KB)                          | –                   | 16    | 16    | 16    | 16    | 16    | 16    |
| RAM (Parity) (KB)                       | –                   | 16    | 16    | 16    | 16    | 16    | 16    |
| IPC Message RAM (Parity) (KB)           | –                   | 2     | 2     | 2     | 2     | 2     | 2     |
| Security Zones                          | –                   | 2     | 2     | 2     | 2     | 2     | 2     |
| 10/100 ENET 1588 MII                    | 0                   | Yes   | Yes   | Yes   | Yes   | No    | No    |
| USB OTG FS                              | 0                   | Yes   | Yes   | Yes   | Yes   | No    | No    |
| SSI/SPI                                 | 0                   | 4     | 4     | 4     | 4     | 4     | 4     |
| UART                                    | 0                   | 5     | 5     | 5     | 5     | 5     | 5     |
| I2C                                     | 0                   | 2     | 2     | 2     | 2     | 2     | 2     |
| CAN <sup>(3)</sup>                      | 0                   | 2     | 2     | 2     | 2     | 2     | 2     |
| μDMA                                    | 0                   | 32-ch | 32-ch | 32-ch | 32-ch | 32-ch | 32-ch |
| EPI <sup>(4)</sup>                      | 0                   | 1     | 1     | 1     | 1     | 1     | 1     |
| μCRC module                             | 0                   | 1     | 1     | 1     | 1     | 1     | 1     |
| General-Purpose Timers                  | –                   | 4     | 4     | 4     | 4     | 4     | 4     |
| Watchdog Timer modules                  | –                   | 2     | 2     | 2     | 2     | 2     | 2     |
| <b>Control Subsystem — C28x</b>         |                     |       |       |       |       |       |       |
| Speed (MHz) <sup>(2)</sup>              |                     | 150   | 150   | 75    | 75    | 75    | 60    |
| FPU                                     |                     | Yes   |       |       |       |       |       |
| VCU                                     |                     | Yes   |       |       |       |       |       |
| Flash (ECC) (KB)                        |                     | 512   | 256   | 512   | 256   | 256   | 256   |
| RAM (ECC) (KB)                          |                     | 20    | 20    | 20    | 20    | 20    | 20    |
| RAM (Parity) (KB)                       |                     | 16    | 16    | 16    | 16    | 16    | 16    |
| IPC Message RAM (Parity) (KB)           |                     | 2     | 2     | 2     | 2     | 2     | 2     |
| Security Zones                          |                     | 1     | 1     | 1     | 1     | 1     | 1     |

**Table 3-1. Device Comparison (continued)**

| FEATURE                             |                                | TYPE <sup>(1)</sup> | H52C   | H22C   | M52C   | M22C   | M20B   | E20B   |
|-------------------------------------|--------------------------------|---------------------|--|--------|--------|--------|--------|--------|
| ePWM modules                        |                                | 2                   | 9: 18 outputs  |        |        |        |        |        |
| High-Resolution PWM (HRPWM) outputs |                                | 2                   | 16 outputs   |        |        |        |        |        |
| eCAP modules/PWM outputs            |                                | 0                   | 6 (32-bit)   |        |        |        |        |        |
| eQEP modules                        |                                | 0                   | 3 (32-bit)   |        |        |        |        |        |
| Fault Trip Zones                    |                                | –                   | 12 on any of 64 GPIO pins  |        |        |        |        |        |
| McBSP/SPI                           |                                | 1                   | 1  | 1      | 1      | 1      | 1      | 1      |
| SCI                                 |                                | 0                   | 1  | 1      | 1      | 1      | 1      | 1      |
| SPI                                 |                                | 0                   | 1  | 1      | 1      | 1      | 1      | 1      |
| I2C                                 |                                | 0                   | 1  | 1      | 1      | 1      | 1      | 1      |
| DMA                                 |                                | 0                   | 6-ch   | 6-ch   | 6-ch   | 6-ch   | 6-ch   | 6-ch   |
| EPI <sup>(4)</sup>                  |                                | 0                   | 1  | 1      | 1      | 1      | 1      | 1      |
| 32-Bit Timers                       |                                | –                   | 3  | 3      | 3      | 3      | 3      | 3      |
| <b>Shared</b>                       |                                |                     |  |        |        |        |        |        |
| Shared RAM (Parity) (KB)            |                                |                     | 64   | 64     | 64     | 64     | 0      | 0      |
| 12-Bit ADC 1                        | MSPS <sup>(5)</sup>            | 3                   | 2.88   | 2.88   | 2.88   | 2.88   | 2.88   | 2.31   |
|                                     | Conversion Time <sup>(5)</sup> |                     | 347 ns   | 347 ns | 347 ns | 347 ns | 347 ns | 433 ns |
|                                     | Channels                       |                     | 10   | 10     | 10     | 10     | 10     | 10     |
|                                     | Sample-and-Hold                |                     | 2  | 2      | 2      | 2      | 2      | 2      |
| 12-Bit ADC 2                        | MSPS <sup>(5)</sup>            | 3                   | 2.88   | 2.88   | 2.88   | 2.88   | 2.88   | 2.31   |
|                                     | Conversion Time <sup>(5)</sup> |                     | 347 ns   | 347 ns | 347 ns | 347 ns | 347 ns | 433 ns |
|                                     | Channels                       |                     | 10   | 10     | 10     | 10     | 10     | 10     |
|                                     | Sample-and-Hold                |                     | 2  | 2      | 2      | 2      | 2      | 2      |
| Comparators with Integrated DACs    |                                | 0                   | 6  | 6      | 6      | 6      | 6      | 6      |
| Voltage Regulator                   |                                |                     | Yes – Uses 3.3-V Single Supply (3.3-V/1.2-V recommended for 125°C)       |        |        |        |        |        |
| Clocking                            |                                |                     | See <a href="#">Section 6.10</a>   |        |        |        |        |        |
| <b>Additional Safety</b>            |                                |                     |  |        |        |        |        |        |
| Master Subsystem                    |                                |                     | 2 Watchdogs, NMI Watchdog: CPU, Memory                                   |        |        |        |        |        |
| Control Subsystem                   |                                |                     | NMI Watchdog: CPU, Memory  |        |        |        |        |        |
| Shared                              |                                |                     | Critical Register and I/O Function Lock Protection; RAM Fetch Protection |        |        |        |        |        |

**Table 3-1. Device Comparison (continued)**

| FEATURE                                |                                  | TYPE <sup>(1)</sup> | H52C | H22C | M52C | M22C | M20B | E20B |
|--|----------------------------------|---------------------|------|------|------|------|------|------|
| <b>Packaging</b>                       |                                  |                     |      |      |      |      |      |      |
| Package Type                           | 144-Pin RFP PowerPAD HTQFP       |                     | Yes  | Yes  | Yes  | Yes  | Yes  | Yes  |
| Junction Temperature (T <sub>J</sub> ) | T: –40°C to 105°C                | –                   | Yes  | Yes  | Yes  | Yes  | Yes  | Yes  |
|  | S: –40°C to 125°C                | –                   | Yes  | Yes  | Yes  | Yes  | Yes  | Yes  |
|  | Q: –40°C to 150°C <sup>(6)</sup> | –                   | Yes  | No   | No   | No   | No   | No   |
| Free-Air Temperature (T <sub>A</sub> ) | Q: –40°C to 125°C <sup>(6)</sup> | –                   | Yes  | No   | No   | No   | No   | No   |

- (1) A type change represents a major functional feature difference in a peripheral module. Within a peripheral type, there may be minor differences between devices that do not affect the basic functionality of the module. These device-specific differences are listed in the [C2000 Real-Time Control Peripherals Reference Guide](#) and in the peripheral reference guides.
- (2) The maximum frequency at which the Cortex-M3 core can run is 100 MHz. The clock divider before the Cortex-M3 core can only take values of /1, /2, or /4. For this reason, when the C28x is configured to run at the maximum frequency of 150 MHz, the fastest allowable frequency for the Cortex-M3 is 75 MHz. If the Cortex-M3 is configured to run at 100 MHz, the maximum frequency of the C28x is limited to 100 MHz.
- (3) The CAN module uses the popular IP known as D\_CAN. This document uses the names “CAN” and “D\_CAN” interchangeably to reference this peripheral.
- (4) Single EPI arbitrated between masters in Master and Control Subsystems.
- (5) An integer divide ratio must be maintained between the C28x and ADC clock frequencies. All MSPS and Conversion Time values are based on the maximum C28x clock frequency.
- (6) “Q” refers to AEC Q100 qualification for automotive applications.

**Table 3-2. Possible Speed Combinations for Cortex-M3 and C28x Cores**

|                  |         |         |        |        |
|------------------|---------|---------|--------|--------|
| <b>Cortex-M3</b> | 75 MHz  | 100 MHz | 75 MHz | 60 MHz |
| <b>C28x</b>      | 150 MHz | 100 MHz | 75 MHz | 60 MHz |

### 3.1 Related Products

For information about other devices in this family of products, see the following link:

[F28M36x Concerto™ Microcontrollers](#)

The F28M3x series of microcontrollers brings together connectivity and control by combining an ARM Cortex-M3 core with the C28x core on to one device. With F28M3x, applications such as solar inverters and industrial control can keep the benefits of separating the communication and control portions while maintaining a single-chip solution. In addition, F28M3x microcontrollers enable safety certifications in your system through enhanced hardware and safety features.

The F28M36x family of devices is the second series in the Concerto family.

## 4 Terminal Configuration and Functions

### 4.1 Pin Diagram

Figure 4-1 shows the 144-pin RFP PowerPAD Thermally Enhanced Thin Quad Flatpack pin assignments.

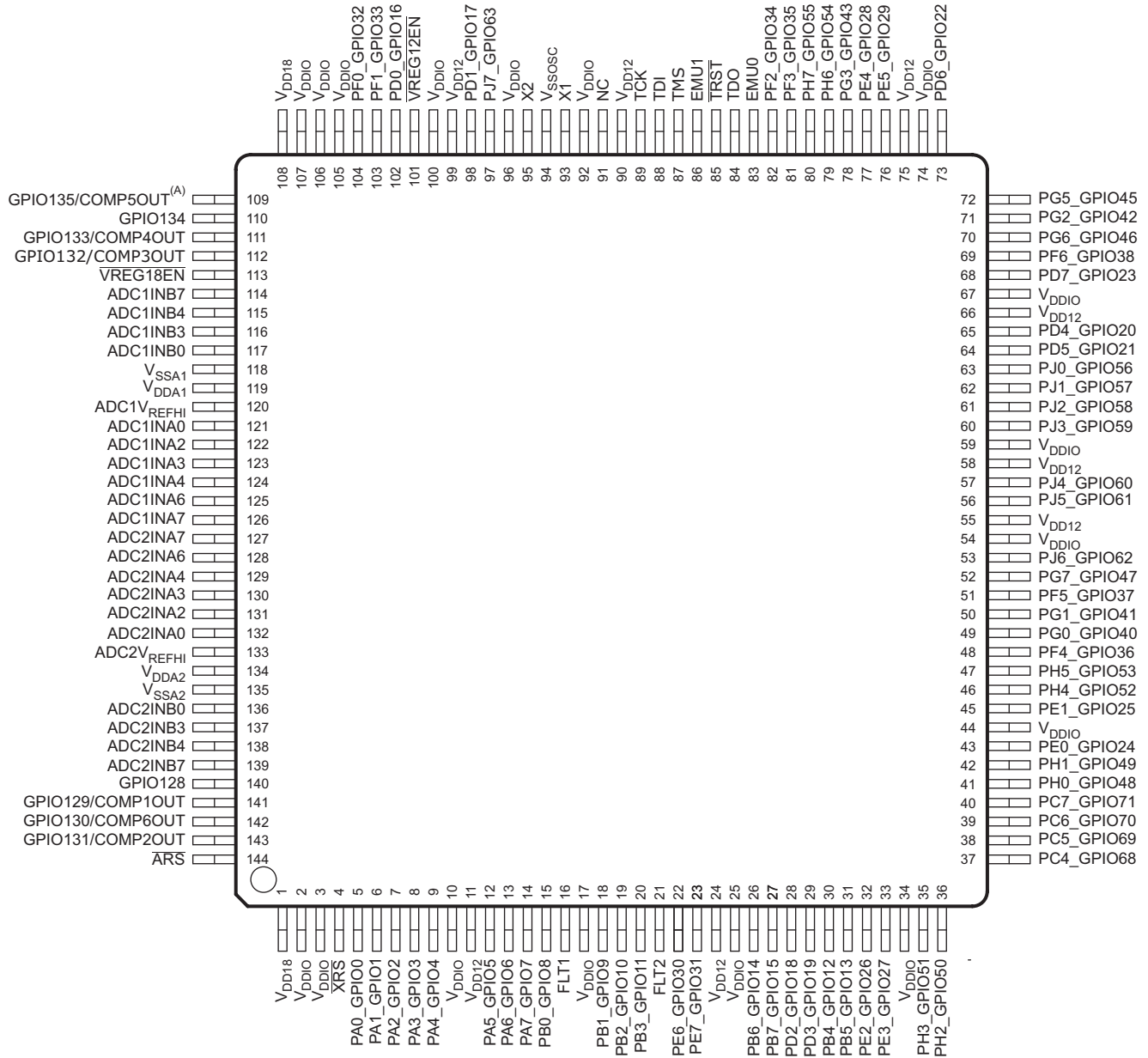

- A. All I/Os, except for GPIO135, are glitch-free during power up and power down. See [Section 6.11](#).
- B. See [Table 4-1](#), Signal Descriptions, for the complete multiplexed signal names.

**Figure 4-1. 144-Pin RFP PowerPAD Thermally Enhanced Thin Quad Flatpack (Top View)**

---

#### NOTE

The exposed lead frame die pad of the PowerPAD package serves two functions: to remove heat from the die and to provide ground path for the digital ground (analog ground is provided through dedicated pins). Thus, the PowerPAD should be soldered to the ground (GND) plane of the PCB because this will provide both the digital ground path and good thermal conduction path. To make optimum use of the thermal efficiencies designed into the PowerPAD package, the PCB must be designed with this technology in mind. A thermal land is required on the surface of the PCB directly underneath the body of the PowerPAD. The thermal land should be soldered to the exposed lead frame die pad of the PowerPAD package; the thermal land should be as large as needed to dissipate the required heat. An array of thermal vias should be used to connect the thermal pad to the internal GND plane of the board. See [PowerPAD™ Thermally Enhanced Package](#) for more details on using the PowerPAD package.

---

## 4.2 Signal Descriptions

Table 4-1 describes the signals.

**Table 4-1. Signal Descriptions<sup>(1)</sup>**

| TERMINAL   |                       | I/O/Z <sup>(2)</sup> | DESCRIPTION   | PU or PD <sup>(3)</sup> | OUTPUT BUFFER STRENGTH |
|--|-----------------------|----------------------|---|-------------------------|------------------------|
| NAME   | RFP PIN NO.           |                      |   |                         |                        |
| <b>ADC 1 Reference Inputs, Analog Comparator Inputs, DAC Inputs, AIO Group 1</b> |                       |                      |   |                         |                        |
| ADC1V <sub>REFHI</sub>   | 120                   | I                    | ADC1 External High Reference – used only when in ADC external reference mode. |                         |                        |
| ADC1V <sub>REFLO</sub>   | see V <sub>SSA1</sub> | I                    | ADC1 External Low Reference – used only when in ADC external reference mode.  |                         |                        |
| ADC1INA0   | 121                   | I                    | ADC1 Group A, Channel 0 input   |                         |                        |
| ADC1INA2   |                       | I                    | ADC1 Group A, Channel 2 input   |                         |                        |
| COMP A1  | 122                   | I                    | Comparator Input A1   |                         | 4 mA                   |
| AIO2   |                       | I/O                  | Digital AIO2  |                         |                        |
| ADC1INA3   | 123                   | I                    | ADC1 Group A, Channel 3 input   |                         |                        |
| ADC1INA4   |                       | I                    | ADC1 Group A, Channel 4 input   |                         |                        |
| COMP A2  | 124                   | I                    | Comparator Input A2   |                         | 4 mA                   |
| AIO4   |                       | I/O                  | Digital AIO4  |                         |                        |
| ADC1INA6   |                       | I                    | ADC1 Group A, Channel 6 input   |                         |                        |
| COMP A3  | 125                   | I                    | Comparator Input A3   |                         | 4 mA                   |
| AIO6   |                       | I/O                  | Digital AIO6  |                         |                        |
| ADC1INA7   | 126                   | I                    | ADC1 Group A, Channel 7 input   |                         |                        |
| ADC1INB0   | 117                   | I                    | ADC1 Group B, Channel 0 input   |                         |                        |
| ADC1INB3   | 116                   | I                    | ADC1 Group B, Channel 3 input   |                         |                        |
| ADC1INB4   |                       | I                    | ADC1 Group B, Channel 4 input   |                         |                        |
| COMP B2  | 115                   | I                    | Comparator Input B2   |                         | 4 mA                   |
| AIO12  |                       | I/O                  | Digital AIO12   |                         |                        |
| ADC1INB7   | 114                   | I                    | ADC1 Group B, Channel 7 input   |                         |                        |
| <b>ADC 2 Reference Inputs, Analog Comparator Inputs, DAC Inputs, AIO Group 2</b> |                       |                      |   |                         |                        |
| ADC2V <sub>REFHI</sub>   | 133                   | I                    | ADC2 External High Reference – used only when in ADC external reference mode. |                         |                        |
| ADC2V <sub>REFLO</sub>   | see V <sub>SSA2</sub> | I                    | ADC2 External Low Reference – used only when in ADC external reference mode.  |                         |                        |
| ADC2INA0   | 132                   | I                    | ADC2 Group A, Channel 0 input   |                         |                        |
| ADC2INA2   |                       | I                    | ADC2 Group A, Channel 2 input   |                         |                        |
| COMP A4  | 131                   | I                    | Comparator Input A4   |                         | 4 mA                   |
| AIO18  |                       | I/O                  | Digital AIO18   |                         |                        |
| ADC2INA3   | 130                   | I                    | ADC2 Group A, Channel 3 input   |                         |                        |
| ADC2INA4   |                       | I                    | ADC2 Group A, Channel 4 input   |                         |                        |
| COMP A5  | 129                   | I                    | Comparator Input A5   |                         | 4 mA                   |
| AIO20  |                       | I/O                  | Digital AIO20   |                         |                        |
| ADC2INA6   |                       | I                    | ADC2 Group A, Channel 6 input   |                         |                        |
| COMP A6  | 128                   | I                    | Comparator Input A6   |                         | 4 mA                   |
| AIO22  |                       | I/O                  | Digital AIO22   |                         |                        |
| ADC2INA7   | 127                   | I                    | ADC2 Group A, Channel 7 input   |                         |                        |
| ADC2INB0   | 136                   | I                    | ADC2 Group B, Channel 0 input   |                         |                        |
| ADC2INB3   | 137                   | I                    | ADC2 Group B, Channel 3 input   |                         |                        |

**Table 4-1. Signal Descriptions<sup>(1)</sup> (continued)**

| TERMINAL   |                | I/O/Z <sup>(2)</sup> | DESCRIPTION  | PU<br>or<br>PD <sup>(3)</sup> | OUTPUT<br>BUFFER<br>STRENGTH |
|--|----------------|----------------------|--|-------------------------------|------------------------------|
| NAME   | RFP<br>PIN NO. |                      |  |                               |                              |
| ADC2INB4   |                | I                    | ADC2 Group B, Channel 4 input  |                               |                              |
| COMPB5   | 138            | I                    | Comparator Input B5  |                               | 4 mA                         |
| AIO28  |                | I/O                  | Digital AIO28  |                               |                              |
| ADC2INB7   | 139            | I                    | ADC2 Group B, Channel 7 input  |                               |                              |
| <b>ADC Modules Analog Power and Ground</b>                                     |                |                      |  |                               |                              |
| V <sub>DDA1</sub>  | 119            |                      | 3.3-V Analog Module 1 Power Pin. Tie with a 2.2-μF capacitor (typical) close to the pin. |                               |                              |
| V <sub>DDA2</sub>  | 134            |                      | 3.3-V Analog Module 2 Power Pin. Tie with a 2.2-μF capacitor (typical) close to the pin. |                               |                              |
| V <sub>SSA1</sub>  | 118            |                      | Analog ground for ADC1, ADC1V <sub>REFLO</sub> , COMP1–3, and DAC1–3                     |                               |                              |
| V <sub>SSA2</sub>  | 135            |                      | Analog ground for ADC2, ADC2V <sub>REFLO</sub> , COMP4–6, and DAC4–6                     |                               |                              |
| <b>Analog Comparator Results (Digital) and GPIO Group 2 (C28x Access Only)</b> |                |                      |  |                               |                              |
| GPIO128  | 140            | I/O                  | General-purpose input/output 128   | PU                            | 4 mA                         |
| GPIO129  |                | I/O                  | General-purpose input/output 129   | PU                            | 4 mA                         |
| COMP1OUT   | 141            | O                    | Compare result from Analog Comparator 1  |                               |                              |
| GPIO130  |                | I/O                  | General-purpose input/output 130   | PU                            | 4 mA                         |
| COMP6OUT   | 142            | O                    | Compare result from Analog Comparator 6  |                               |                              |
| GPIO131  |                | I/O                  | General-purpose input/output 131   | PU                            | 4 mA                         |
| COMP2OUT   | 143            | O                    | Compare result from Analog Comparator 2  |                               |                              |
| GPIO132  |                | I/O                  | General-purpose input/output 132   | PU                            | 8 mA                         |
| COMP3OUT   | 112            | O                    | Compare result from Analog Comparator 3  |                               |                              |
| GPIO133  |                | I/O                  | General-purpose input/output 133   | PU                            | 4 mA                         |
| COMP4OUT   | 111            | O                    | Compare result from Analog Comparator 4  |                               |                              |
| GPIO134  |                | I/O                  | General-purpose input/output 134   | PU                            | 4 mA                         |
| GPIO135 <sup>(4)</sup>   |                | I/O                  | General-purpose input/output 135   | PU                            | 8 mA                         |
| COMP5OUT   | 109            | O                    | Compare result from Analog Comparator 5  |                               |                              |

**Table 4-1. Signal Descriptions<sup>(1)</sup> (continued)**

| TERMINAL                                   |             | I/O/Z <sup>(2)</sup>            | DESCRIPTION  | PU or PD <sup>(3)</sup> | OUTPUT BUFFER STRENGTH |
|--|-------------|---------------------------------|--|-------------------------|------------------------|
| NAME                                       | RFP PIN NO. |                                 |  |                         |                        |
| <b>GPIO Group 1 and Peripheral Signals</b> |             |                                 |  |                         |                        |
| PA0_GPIO0                                  | 5           | I/O/Z                           | General-purpose input/output 0                             | PU                      | 4 mA                   |
| M_U0RX                                     |             | I                               | UART-0 receive data  |                         |                        |
| M_I2C1SCL                                  |             | I/OD                            | I2C-1 clock open-drain bidirectional port                  |                         |                        |
| M_U1RX                                     |             | I                               | UART-1 receive data  |                         |                        |
| C_EPWM1A                                   |             | O                               | Enhanced PWM-1 output A                                    |                         |                        |
| PA1_GPIO1                                  | 6           | I/O/Z                           | General-purpose input/output 1                             | PU                      | 4 mA                   |
| M_U0TX                                     |             | O                               | UART-0 transmit data                                       |                         |                        |
| M_I2C1SDA                                  |             | I/OD                            | I2C-1 data open-drain bidirectional port                   |                         |                        |
| M_U1TX                                     |             | O                               | UART-1 data transmit                                       |                         |                        |
| M_SSI1FSS                                  |             | I/O                             | SSI-1 frame  |                         |                        |
| C_EPWM1B                                   |             | O                               | Enhanced PWM-1 output B                                    |                         |                        |
| C_ECAP6                                    | I/O         | Enhanced Capture-6 input/output |  |                         |                        |
| PA2_GPIO2                                  | 7           | I/O/Z                           | General-purpose input/output 2                             | PU                      | 4 mA                   |
| M_SSI0CLK                                  |             | I/O                             | SSI-0 clock  |                         |                        |
| M_MII_TXD2                                 |             | O                               | EMAC MII transmit data bit 2                               |                         |                        |
| C_EPWM2A                                   |             | O                               | Enhanced PWM-2 output A                                    |                         |                        |
| PA3_GPIO3                                  | 8           | I/O/Z                           | General-purpose input/output 3                             | PU                      | 4 mA                   |
| M_SSI0FSS                                  |             | I/O                             | SSI-0 frame  |                         |                        |
| M_MII_TXD1                                 |             | O                               | EMAC MII transmit data bit 1                               |                         |                        |
| M_SSI1CLK                                  |             | I/O                             | SSI-1 clock  |                         |                        |
| C_EPWM2B                                   |             | O                               | Enhanced PWM-2 output B                                    |                         |                        |
| C_ECAP5                                    |             | I/O                             | Enhanced Capture-5 input/output                            |                         |                        |
| PA4_GPIO4                                  | 9           | I/O/Z                           | General-purpose input/output 4                             | PU                      | 4 mA                   |
| M_SSI0RX                                   |             | I                               | SSI-0 receive data   |                         |                        |
| M_MII_TXD0                                 |             | O                               | EMAC MII transmit data bit 0                               |                         |                        |
| M_CAN0RX                                   |             | I                               | CAN-0 receive data   |                         |                        |
| C_EPWM3A                                   |             | O                               | Enhanced PWM-3 output A                                    |                         |                        |
| PA5_GPIO5                                  | 12          | I/O/Z                           | General-purpose input/output 5                             | PU                      | 4 mA                   |
| M_SSI0TX                                   |             | O                               | SSI-0 transmit data  |                         |                        |
| M_MII_RXDV                                 |             | I                               | EMAC MII receive data valid                                |                         |                        |
| M_CAN0TX                                   |             | O                               | CAN-0 transmit data  |                         |                        |
| C_EPWM3B                                   |             | O                               | Enhanced PWM-3 output B                                    |                         |                        |
| C_MFSRA                                    |             | I                               | McBSP-A receive frame sync                                 |                         |                        |
| C_ECAP1                                    |             | I/O                             | Enhanced Capture-1 input/output                            |                         |                        |
| PA6_GPIO6                                  | 13          | I/O/Z                           | General-purpose input/output 6                             | PU                      | 4 mA                   |
| M_I2C1SCL                                  |             | I/OD                            | I2C-1 clock open-drain bidirectional port                  |                         |                        |
| M_CCP1                                     |             | I/O                             | Capture/Compare/PWM-1 (General-purpose Timer)              |                         |                        |
| M_MII_RXCK                                 |             | I                               | EMAC MII receive clock                                     |                         |                        |
| M_CAN0RX                                   |             | I                               | CAN-0 receive data   |                         |                        |
| M_USB0EPEN                                 |             | O                               | USB-0 external power enable (optionally used in host mode) |                         |                        |
| M_MII_TXD3                                 |             | O                               | EMAC MII transmit data bit 3                               |                         |                        |
| C_EPWM4A                                   |             | O                               | Enhanced PWM-4 output A                                    |                         |                        |
| C_EPWMSYNCO                                |             | O                               | Enhanced PWM-4 external sync pulse                         |                         |                        |

**Table 4-1. Signal Descriptions<sup>(1)</sup> (continued)**

| TERMINAL   |                | I/O/Z <sup>(2)</sup>            | DESCRIPTION  | PU<br>or<br>PD <sup>(3)</sup> | OUTPUT<br>BUFFER<br>STRENGTH |
|------------|----------------|---------------------------------|--|-------------------------------|------------------------------|
| NAME       | RFP<br>PIN NO. |                                 |  |                               |                              |
| PA7_GPIO7  | 14             | I/O/Z                           | General-purpose input/output 7   | PU                            | 4 mA                         |
| M_I2C1SDA  |                | I/OD                            | I2C-1 data open-drain bidirectional port                               |                               |                              |
| M_CCP4     |                | I/O                             | Capture/Compare/PWM-4<br>(General-purpose Timer)                       |                               |                              |
| M_MIIRXER  |                | I                               | EMAC MII receive error   |                               |                              |
| M_CAN0TX   |                | O                               | CAN-0 transmit data  |                               |                              |
| M_CCP3     |                | I/O                             | Capture/Compare/PWM-3<br>(General-purpose Timer)                       |                               |                              |
| M_USB0PFLT |                | I                               | USB-0 external power error state<br>(optionally used in the host mode) |                               |                              |
| M_MIIRXD1  |                | I                               | EMAC MII receive data 1  |                               |                              |
| C_EPWM4B   |                | O                               | Enhanced PWM-4 output B  |                               |                              |
| C_MCLKRA   |                | I                               | McBSP-A receive clock  |                               |                              |
| C_ECAPP2   | I/O            | Enhanced Capture-1 input/output |  |                               |                              |
| PB0_GPIO8  | 15             | I/O/Z                           | General-purpose input/output 8   | PU                            | 4 mA                         |
| M_CCP0     |                | I/O                             | Capture/Compare/PWM-0<br>(General-purpose Timer)                       |                               |                              |
| M_U1RX     |                | I                               | UART-1 data receive data   |                               |                              |
| M_SSI2TX   |                | O                               | SSI-2 transmit data  |                               |                              |
| M_CAN1TX   |                | O                               | CAN-1 transmit data  |                               |                              |
| M_U4TX     |                | O                               | UART-4 transmit data   |                               |                              |
| C_EPWM5A   |                | O                               | Enhanced PWM-5 output A  |                               |                              |
| C_ADCSOCAO |                | O                               | ADC start-of-conversion A  |                               |                              |
| PB1_GPIO9  | 18             | I/O/Z                           | General-purpose input/output 9   | PU                            | 4 mA                         |
| M_CCP2     |                | I/O                             | Capture/Compare/PWM-2<br>(General-purpose Timer)                       |                               |                              |
| M_CCP1     |                | I/O                             | Capture/Compare/PWM-1<br>(General-purpose Timer)                       |                               |                              |
| M_U1TX     |                | O                               | UART-1 transmit data   |                               |                              |
| M_SSI2RX   |                | I                               | SSI-2 receive data   |                               |                              |
| C_EPWM5B   |                | O                               | Enhanced PWM-5 output B  |                               |                              |
| C_ECAPP3   |                | I/O                             | Enhanced Capture-3 input/output  |                               |                              |
| PB2_GPIO10 | 19             | I/O/Z                           | General-purpose input/output 10  | PU                            | 4 mA                         |
| M_I2C0SCL  |                | I/OD                            | I2C-0 clock open-drain bidirectional port                              |                               |                              |
| M_CCP3     |                | I/O                             | Capture/Compare/PWM-3<br>(General-purpose Timer)                       |                               |                              |
| M_CCP0     |                | I/O                             | Capture/Compare/PWM-0<br>(General-purpose Timer)                       |                               |                              |
| M_USB0EPEN |                | O                               | USB-0 external power enable<br>(optionally used in the host mode)      |                               |                              |
| M_SSI2CLK  |                | I/O                             | SSI-2 clock  |                               |                              |
| M_CAN1RX   |                | I                               | CAN-1 receive data   |                               |                              |
| M_U4RX     |                | I                               | UART-4 receive data  |                               |                              |
| C_EPWM6A   |                | O                               | Enhanced PWM-6 output A  |                               |                              |
| C_ADCSOCBO |                | O                               | ADC start-of-conversion B  |                               |                              |

**Table 4-1. Signal Descriptions<sup>(1)</sup> (continued)**

| TERMINAL                 |             | I/O/Z <sup>(2)</sup>    | DESCRIPTION   | PU or PD <sup>(3)</sup> | OUTPUT BUFFER STRENGTH |
|--------------------------|-------------|-------------------------|---|-------------------------|------------------------|
| NAME                     | RFP PIN NO. |                         |   |                         |                        |
| PB3_GPIO11               | 20          | I/O/Z                   | General-purpose input/output 11                                     | PU                      | 4 mA                   |
| M_I2C0SDA                |             | I/OD                    | I2C-0 data open-drain bidirectional port                            |                         |                        |
| M_USB0PFLT               |             | I                       | USB-0 external power error state (optionally used in the host mode) |                         |                        |
| M_SSI2FSS                |             | I/O                     | SSI-2 frame   |                         |                        |
| M_U1RX                   |             | I                       | UART-1 receive data   |                         |                        |
| C_EPWM6B                 |             | O                       | Enhanced PWM-6 output B   |                         |                        |
| C_ECAP4                  |             | I/O                     | Enhanced Capture-4 input/output                                     |                         |                        |
| PB4_GPIO12               | 30          | I/O/Z                   | General-purpose input/output 12                                     | PU                      | 4 mA                   |
| M_U2RX                   |             | I                       | UART-2 receive data   |                         |                        |
| M_CAN0RX                 |             | I                       | CAN-0 receive data  |                         |                        |
| M_U1RX                   |             | I                       | UART-1 receive data   |                         |                        |
| M_EPI0S23                |             | I/O                     | EPI-0 signal 23   |                         |                        |
| M_CAN1TX                 |             | O                       | CAN-1 transmit data   |                         |                        |
| M_SSI1TX                 |             | O                       | SSI-1 transmit data   |                         |                        |
| C_EPWM7A                 | O           | Enhanced PWM-7 output A |   |                         |                        |
| PB5_GPIO13               | 31          | I/O/Z                   | General-purpose input/output 13                                     | PU                      | 4 mA                   |
| M_CCP5                   |             | I/O                     | Capture/Compare/PWM-5 (General-purpose Timer)                       |                         |                        |
| M_CCP6                   |             | I/O                     | Capture/Compare/PWM-6 (General-purpose Timer)                       |                         |                        |
| M_CCP0                   |             | I/O                     | Capture/Compare/PWM-0 (General-purpose Timer)                       |                         |                        |
| M_CAN0TX                 |             | O                       | CAN-0 transmit data   |                         |                        |
| M_CCP2                   |             | I/O                     | Capture/Compare/PWM-2 (General-purpose Timer)                       |                         |                        |
| M_U1TX                   |             | O                       | UART-1 transmit data  |                         |                        |
| M_EPI0S22                |             | I/O                     | EPI-0 signal 22   |                         |                        |
| M_CAN1RX                 |             | I                       | CAN-1 receive data  |                         |                        |
| M_SSI1RX                 |             | I                       | SSI-1 receive data  |                         |                        |
| C_EPWM7B                 | O           | Enhanced PWM-7 output B |   |                         |                        |
| PB6_GPIO14               | 26          | I/O/Z                   | General-purpose input/output 14                                     | PU                      | 4 mA                   |
| M_CCP1                   |             | I/O                     | Capture/Compare/PWM-1 (General-purpose Timer)                       |                         |                        |
| M_CCP7                   |             | I/O                     | Capture/Compare/PWM-7 (General-purpose Timer)                       |                         |                        |
| M_CCP5                   |             | I/O                     | Capture/Compare/PWM-5 (General-purpose Timer)                       |                         |                        |
| M_EPI0S37 <sup>(5)</sup> |             | I/O                     | EPI-0 signal 37   |                         |                        |
| M_MII CRS                |             | I                       | EMAC MII carrier sense  |                         |                        |
| M_I2C0SDA                |             | I/OD                    | I2C-0 data open-drain bidirectional port                            |                         |                        |
| M_U1TX                   |             | O                       | UART-1 transmit data  |                         |                        |
| M_SSI1CLK                |             | I/O                     | SSI-1 clock   |                         |                        |
| C_EPWM8A                 | O           | Enhanced PWM-8 output A |   |                         |                        |

**Table 4-1. Signal Descriptions<sup>(1)</sup> (continued)**

| TERMINAL                 |                | I/O/Z <sup>(2)</sup>       | DESCRIPTION  | PU<br>or<br>PD <sup>(3)</sup> | OUTPUT<br>BUFFER<br>STRENGTH |
|--------------------------|----------------|----------------------------|--|-------------------------------|------------------------------|
| NAME                     | RFP<br>PIN NO. |                            |  |                               |                              |
| PB7_GPIO15               | 27             | I/O/Z                      | General-purpose input/output 15  | PU                            | 4 mA                         |
| M_EXTNMI                 |                | I                          | Cortex-M3 external nonmaskable interrupt                               |                               |                              |
| M_MIIRXD1                |                | I                          | EMAC MII receive data 1  |                               |                              |
| M_EPI0S36 <sup>(5)</sup> |                | I/O                        | EPI-0 signal 36  |                               |                              |
| M_I2C0SCL                |                | I/OD                       | I2C-0 clock open-drain bidirectional port                              |                               |                              |
| M_U1RX                   |                | I                          | UART-1 receive data  |                               |                              |
| M_SSI1FSS                |                | I/O                        | SSI-1 frame  |                               |                              |
| C_EPWM8B                 |                | O                          | Enhanced PWM-8 output B  |                               |                              |
| PD0_GPIO16               | 102            | I/O/Z                      | General-purpose input/output 16  | PU                            | 4 mA                         |
| M_CAN0RX                 |                | I                          | CAN-0 receive data   |                               |                              |
| M_U2RX                   |                | I                          | UART-2 receive data  |                               |                              |
| M_U1RX                   |                | I                          | UART-1 receive data  |                               |                              |
| M_CCP6                   |                | I/O                        | Capture/Compare/PWM-6<br>(General-purpose Timer)                       |                               |                              |
| M_MIIRXDV                |                | I                          | EMAC MII receive data valid  |                               |                              |
| M_MIIRXD2                |                | I                          | EMAC MII receive data 2  |                               |                              |
| M_SSI0TX                 |                | O                          | SSI-0 transmit data  |                               |                              |
| M_CAN1TX                 |                | O                          | CAN-1 transmit data  |                               |                              |
| M_USB0EPEN               |                | O                          | USB-0 external power enable<br>(optionally used in the host mode)      |                               |                              |
| C_SPISIMOA               | I/O            | SPI-A slave in, master out |  |                               |                              |
| PD1_GPIO17               | 98             | I/O/Z                      | General-purpose input/output 17  | PU                            | 4 mA                         |
| M_CAN0TX                 |                | O                          | CAN-0 transmit data  |                               |                              |
| M_U2TX                   |                | O                          | UART-2 transmit data   |                               |                              |
| M_U1TX                   |                | O                          | UART-1 transmit data   |                               |                              |
| M_CCP7                   |                | I/O                        | Capture/Compare/PWM-7<br>(General-purpose Timer)                       |                               |                              |
| M_MIITXER                |                | O                          | EMAC MII transmit error  |                               |                              |
| M_CCP2                   |                | I/O                        | Capture/Compare/PWM-2<br>(General-purpose Timer)                       |                               |                              |
| M_MIICOL                 |                | I                          | EMAC MII collision detect  |                               |                              |
| M_SSI0RX                 |                | I                          | SSI-0 receive data   |                               |                              |
| M_CAN1RX                 |                | I                          | CAN-1 receive data   |                               |                              |
| M_USB0PFLT               |                | I                          | USB-0 external power error state<br>(optionally used in the host mode) |                               |                              |
| C_SPISOMIA               |                | I/O                        | SPI-A master in, slave out   |                               |                              |
| PD2_GPIO18               | 28             | I/O/Z                      | General-purpose input/output 18  | PU                            | 4 mA                         |
| M_U1RX                   |                | I                          | UART-1 receive data  |                               |                              |
| M_CCP6                   |                | I/O                        | Capture/Compare/PWM-6<br>(General-purpose Timer)                       |                               |                              |
| M_CCP5                   |                | I/O                        | Capture/Compare/PWM-5<br>(General-purpose Timer)                       |                               |                              |
| M_EPI0S20                |                | I/O                        | EPI-0 signal 20  |                               |                              |
| M_SSI0CLK                |                | I/O                        | SSI-0 clock  |                               |                              |
| M_U1TX                   |                | O                          | UART-1 transmit data   |                               |                              |
| M_CAN0RX                 |                | I                          | CAN-0 receive data   |                               |                              |
| C_SPICLK_A               |                | I/O                        | SPI-A clock  |                               |                              |

**Table 4-1. Signal Descriptions<sup>(1)</sup> (continued)**

| TERMINAL   |             | I/O/Z <sup>(2)</sup> | DESCRIPTION                                   | PU or PD <sup>(3)</sup> | OUTPUT BUFFER STRENGTH |
|------------|-------------|----------------------|---|-------------------------|------------------------|
| NAME       | RFP PIN NO. |                      |   |                         |                        |
| PD3_GPIO19 | 29          | I/O/Z                | General-purpose input/output 19               | PU                      | 4 mA                   |
| M_U1TX     |             | O                    | UART-1 transmit data                          |                         |                        |
| M_CCP7     |             | I/O                  | Capture/Compare/PWM-7 (General-purpose Timer) |                         |                        |
| M_CCP0     |             | I/O                  | Capture/Compare/PWM-0 (General-purpose Timer) |                         |                        |
| M_EPI0S21  |             | I/O                  | EPI-0 signal 21                               |                         |                        |
| M_SSI0FSS  |             | I/O                  | SSI-0 frame                                   |                         |                        |
| M_U1RX     |             | I                    | UART-1 receive data                           |                         |                        |
| M_CAN0TX   |             | O                    | CAN-0 transmit data                           |                         |                        |
| C_SPISTEAA |             | I/O                  | SPI-A slave transmit enable                   |                         |                        |
| PD4_GPIO20 | 65          | I/O/Z                | General-purpose input/output 20               | PU                      | 4 mA                   |
| M_CCP0     |             | I/O                  | Capture/Compare/PWM-0 (General-purpose Timer) |                         |                        |
| M_CCP3     |             | I/O                  | Capture/Compare/PWM-3 (General-purpose Timer) |                         |                        |
| M_MIITXD3  |             | O                    | EMAC MII transmit data 3                      |                         |                        |
| M_EPI0S19  |             | I/O                  | EPI-0 signal 19                               |                         |                        |
| M_U3TX     |             | O                    | UART-3 transmit data                          |                         |                        |
| M_CAN1TX   |             | O                    | CAN-1 transmit data                           |                         |                        |
| C_EQEP1A   |             | I                    | Enhanced QEP-1 input A                        |                         |                        |
| C_MDXA     |             | O                    | McBSP-A transmit data                         |                         |                        |
| PD5_GPIO21 | 64          | I/O/Z                | General-purpose input/output 21               | PU                      | 6 mA                   |
| M_CCP2     |             | I/O                  | Capture/Compare/PWM-2 (General-purpose Timer) |                         |                        |
| M_CCP4     |             | I/O                  | Capture/Compare/PWM-4 (General-purpose Timer) |                         |                        |
| M_MIITXD2  |             | O                    | EMAC MII transmit data 2                      |                         |                        |
| M_U2RX     |             | I                    | UART-2 receive data                           |                         |                        |
| M_EPI0S28  |             | I/O                  | EPI-0 signal 28                               |                         |                        |
| M_U3RX     |             | I                    | UART-3 receive data                           |                         |                        |
| M_CAN1RX   |             | I                    | CAN-1 receive data                            |                         |                        |
| C_EQEP1B   |             | I                    | Enhanced QEP-1 input B                        |                         |                        |
| C_MDRA     | I           | McBSP-A receive data |   |                         |                        |
| PD6_GPIO22 | 73          | I/O/Z                | General-purpose input/output 22               | PU                      | 6 mA                   |
| M_MIITXD1  |             | O                    | EMAC MII transmit data 1                      |                         |                        |
| M_U2TX     |             | O                    | UART-2 transmit data                          |                         |                        |
| M_EPI0S29  |             | I/O                  | EPI-0 signal 29                               |                         |                        |
| M_I2C1SDA  |             | I/OD                 | I2C-0 data open-drain bidirectional port      |                         |                        |
| M_U1TX     |             | O                    | UART-1 transmit data                          |                         |                        |
| C_EQEP1S   |             | I/O                  | Enhanced QEP-1 strobe                         |                         |                        |
| C_MCLKXA   |             | O                    | McBSP-A transmit clock                        |                         |                        |

**Table 4-1. Signal Descriptions<sup>(1)</sup> (continued)**

| TERMINAL   |                | I/O/Z <sup>(2)</sup> | DESCRIPTION  | PU<br>or<br>PD <sup>(3)</sup> | OUTPUT<br>BUFFER<br>STRENGTH |
|------------|----------------|----------------------|--|-------------------------------|------------------------------|
| NAME       | RFP<br>PIN NO. |                      |  |                               |                              |
| PD7_GPIO23 | 68             | I/O/Z                | General-purpose input/output 23  | PU                            | 6 mA                         |
| M_CCP1     |                | I/O                  | Capture/Compare/PWM-1<br>(General-purpose Timer)                       |                               |                              |
| M_MII_TXD0 |                | O                    | EMAC MII transmit data 0   |                               |                              |
| M_EPI0S30  |                | I/O                  | EPI-0 signal 30  |                               |                              |
| M_I2C1SCL  |                | I/OD                 | I2C-1 clock open-drain bidirectional port                              |                               |                              |
| M_U1RX     |                | I                    | UART-1 receive data  |                               |                              |
| C_EQEP1I   |                | I/O                  | Enhanced QEP-1 index   |                               |                              |
| C_MFSXA    |                | O                    | McBSP-A transmit frame sync  |                               |                              |
| PE0_GPIO24 | 43             | I/O/Z                | General-purpose input/output 24  | PU                            | 4 mA                         |
| M_SSI1CLK  |                | I/O                  | SSI-1 clock  |                               |                              |
| M_CCP3     |                | I/O                  | Capture/Compare/PWM-3<br>(General-purpose Timer)                       |                               |                              |
| M_EPI0S8   |                | I/O                  | EPI-0 signal 8   |                               |                              |
| M_USB0PFLT |                | I                    | USB-0 external power error state<br>(optionally used in the host mode) |                               |                              |
| M_SSI3TX   |                | O                    | SSI-3 transmit data  |                               |                              |
| M_CAN0RX   |                | I                    | CAN-1 receive data   |                               |                              |
| M_SSI1TX   |                | O                    | SSI-1 transmit data  |                               |                              |
| C_ECAP1    |                | I/O                  | Enhanced Capture-1 input/output  |                               |                              |
| C_EQEP2A   |                | I                    | Enhanced QEP-2 input A   |                               |                              |
| PE1_GPIO25 | 45             | I/O/Z                | General-purpose input/output 25  | PU                            | 4 mA                         |
| M_SSI1FSS  |                | I/O                  | SSI-1 frame  |                               |                              |
| M_CCP2     |                | I/O                  | Capture/Compare/PWM-2<br>(General-purpose Timer)                       |                               |                              |
| M_CCP6     |                | I/O                  | Capture/Compare/PWM-6<br>(General-purpose Timer)                       |                               |                              |
| M_EPI0S9   |                | I/O                  | EPI-0 signal 9   |                               |                              |
| M_SSI3RX   |                | I                    | SSI-3 receive data   |                               |                              |
| M_CAN0TX   |                | O                    | CAN-1 transmit data  |                               |                              |
| M_SSI1RX   |                | O                    | SSI-1 receive data   |                               |                              |
| C_ECAP2    |                | I/O                  | Enhanced Capture-2 input/output  |                               |                              |
| C_EQEP2B   |                | I                    | Enhanced QEP-2 input B   |                               |                              |
| PE2_GPIO26 | 32             | I/O/Z                | General-purpose input/output 26  | PU                            | 4 mA                         |
| M_CCP4     |                | I/O                  | Capture/Compare/PWM-4<br>(General-purpose Timer)                       |                               |                              |
| M_SSI1RX   |                | I                    | SSI-1 receive data   |                               |                              |
| M_CCP2     |                | I/O                  | Capture/Compare/PWM-2<br>(General-purpose Timer)                       |                               |                              |
| M_EPI0S24  |                | I/O                  | EPI-0 signal 24  |                               |                              |
| M_SSI3CLK  |                | I/O                  | SSI-3 clock  |                               |                              |
| M_U2RX     |                | I                    | UART-2 receive data  |                               |                              |
| M_SSI1CLK  |                | I/O                  | SSI-1 clock  |                               |                              |
| C_ECAP3    |                | I/O                  | Enhanced Capture-3 input/output  |                               |                              |
| C_EQEP2I   |                | I/O                  | Enhanced QEP-2 index   |                               |                              |

**Table 4-1. Signal Descriptions<sup>(1)</sup> (continued)**

| TERMINAL                 |             | I/O/Z <sup>(2)</sup> | DESCRIPTION   | PU or PD <sup>(3)</sup> | OUTPUT BUFFER STRENGTH |
|--------------------------|-------------|----------------------|---|-------------------------|------------------------|
| NAME                     | RFP PIN NO. |                      |   |                         |                        |
| PE3_GPIO27               | 33          | I/O/Z                | General-purpose input/output 27                                     | PU                      | 4 mA                   |
| M_CCP1                   |             | I/O                  | Capture/Compare/PWM-1 (General-purpose Timer)                       |                         |                        |
| M_SSI1TX                 |             | O                    | SSI-1 transmit data   |                         |                        |
| M_CCP7                   |             | I/O                  | Capture/Compare/PWM-7 (General-purpose Timer)                       |                         |                        |
| M_EPI0S25                |             | I/O                  | EPI-0 signal 25   |                         |                        |
| M_SSI3FSS                |             | I/O                  | SSI-3 frame   |                         |                        |
| M_U2TX                   |             | O                    | UART-2 transmit data  |                         |                        |
| M_SSI1FSS                |             | I/O                  | SSI-1 frame   |                         |                        |
| C_ECAP4                  |             | I/O                  | Enhanced Capture-4 input/output                                     |                         |                        |
| C_EQEP2S                 |             | I/O                  | Enhanced QEP-2 strobe   |                         |                        |
| PE4_GPIO28               | 77          | I/O/Z                | General-purpose input/output 28                                     | PU                      | 4 mA                   |
| M_CCP3                   |             | I/O                  | Capture/Compare/PWM-3 (General-purpose Timer)                       |                         |                        |
| M_U2TX                   |             | O                    | UART-2 transmit data  |                         |                        |
| M_CCP2                   |             | I/O                  | Capture/Compare/PWM-2 (General-purpose Timer)                       |                         |                        |
| M_MIIRXD0                |             | I                    | EMAC MII receive data 0   |                         |                        |
| M_EPI0S34 <sup>(5)</sup> |             | I/O                  | EPI-0 signal 34   |                         |                        |
| M_U0RX                   |             | I                    | UART-0 receive data   |                         |                        |
| M_EPI0S38 <sup>(5)</sup> |             | I/O                  | EPI-0 signal 38   |                         |                        |
| M_USB0EPEN               |             | O                    | USB-0 external power enable (optionally used in the host mode)      |                         |                        |
| C_SCIRXDA                |             | I                    | SCI-A receive data  |                         |                        |
| PE5_GPIO29               | 76          | I/O/Z                | General-purpose input/output 29                                     | PU                      | 4 mA                   |
| M_CCP5                   |             | I/O                  | Capture/Compare/PWM-5 (General-purpose Timer)                       |                         |                        |
| M_EPI0S35 <sup>(5)</sup> |             | I/O                  | EPI-0 signal 35   |                         |                        |
| M_MIITXER                |             | O                    | EMAC MII transmit error   |                         |                        |
| M_U0TX                   |             | O                    | UART-0 transmit data  |                         |                        |
| M_USB0PFLT               |             | I                    | USB-0 external power error state (optionally used in the host mode) |                         |                        |
| C_SCITXDA                |             | O                    | SCI-A transmit data   |                         |                        |
| PE6_GPIO30               | 22          | I/O/Z                | General-purpose input/output 30                                     | PU                      | 4 mA                   |
| M_MIIMDIO                |             | I/O                  | EMAC management data input/output                                   |                         |                        |
| M_CAN0RX                 |             | I                    | CAN-0 receive data  |                         |                        |
| C_EPWM9A                 |             | O                    | Enhanced PWM-9 output A   |                         |                        |
| PE7_GPIO31               | 23          | I/O/Z                | General-purpose input/output 31                                     | PU                      | 4 mA                   |
| M_MIIRXD3                |             | I                    | EMAC MII receive data 3   |                         |                        |
| M_CAN0TX                 |             | O                    | CAN-0 transmit data   |                         |                        |
| C_EPWM9B                 |             | O                    | Enhanced PWM-9 output B   |                         |                        |

**Table 4-1. Signal Descriptions<sup>(1)</sup> (continued)**

| TERMINAL                 |                | I/O/Z <sup>(2)</sup>                     | DESCRIPTION                                      | PU<br>or<br>PD <sup>(3)</sup> | OUTPUT<br>BUFFER<br>STRENGTH |
|--------------------------|----------------|--|--|-------------------------------|------------------------------|
| NAME                     | RFP<br>PIN NO. |  |  |                               |                              |
| PF0_GPIO32               | 104            | I/O/Z                                    | General-purpose input/output 32                  | PU                            | 4 mA                         |
| M_CAN1RX                 |                | I  | CAN-1 receive data                               |                               |                              |
| M_MIIRXCK                |                | I  | EMAC MII receive clock                           |                               |                              |
| M_I2C0SDA                |                | I/OD                                     | I2C-0 data open-drain bidirectional port         |                               |                              |
| M_TRACED2                |                | O  | Trace data 2                                     |                               |                              |
| C_I2CASDA                |                | I/OD                                     | I2C-A data open-drain bidirectional port         |                               |                              |
| C_SCIRXDA                |                | I  | SCI-A receive data                               |                               |                              |
| C_ADCSOCAO               |                | O  | ADC start-of-conversion A <sup>(6)</sup>         |                               |                              |
| PF1_GPIO33               | 103            | I/O/Z                                    | General-purpose input/output 33                  | PU                            | 4 mA                         |
| M_CAN1TX                 |                | O  | CAN-1 transmit data                              |                               |                              |
| M_MIIRXER                |                | I  | EMAC MII receive error                           |                               |                              |
| M_CCP3                   |                | I/O                                      | Capture/Compare/PWM-3<br>(General-purpose Timer) |                               |                              |
| M_I2C0SCL                |                | I/OD                                     | I2C-0 clock open-drain bidirectional port        |                               |                              |
| M_TRACED3                |                | O  | Trace data 3                                     |                               |                              |
| C_I2CASCL                |                | I/OD                                     | I2C-A clock open-drain bidirectional port        |                               |                              |
| C_EPWMSYNCO              |                | O  | Enhanced PWM sync out                            |                               |                              |
| C_ADCSOCBO               | O              | ADC start-of-conversion B <sup>(6)</sup> |  |                               |                              |
| PF2_GPIO34               | 82             | I/O/Z                                    | General-purpose input/output 34                  | PU                            | 4 mA                         |
| M_MIIPHYINTR             |                | I  | EMAC PHY MII interrupt                           |                               |                              |
| M_EPI0S32 <sup>(5)</sup> |                | I/O                                      | EPI-0 signal 32                                  |                               |                              |
| M_SSI1CLK                |                | I/O                                      | SSI-1 clock                                      |                               |                              |
| M_TRACECLK               |                | O  | Trace clock                                      |                               |                              |
| M_XCLKOUT                |                | O  | External output clock                            |                               |                              |
| C_ECAP1                  |                | I/O                                      | Enhanced Capture-1 input/output                  |                               |                              |
| C_SCIRXDA                |                | I  | SCI-A receive data                               |                               |                              |
| C_XCLKOUT                |                | O  | External output clock                            |                               |                              |
| Bmode_pin4               | I              | Boot mode pin 4                          |  |                               |                              |
| PF3_GPIO35               | 81             | I/O/Z                                    | General-purpose input/output 35                  | PU                            | 4 mA                         |
| M_MIIMDC                 |                | I  | EMAC management data clock                       |                               |                              |
| M_EPI0S33 <sup>(5)</sup> |                | I/O                                      | EPI-0 signal 33                                  |                               |                              |
| M_SSI1FSS                |                | I/O                                      | SSI-1 frame                                      |                               |                              |
| M_U0TX                   |                | O  | UART-0 transmit data                             |                               |                              |
| M_TRACED0                |                | O  | Trace data 0                                     |                               |                              |
| C_SCITXDA                |                | O  | SCI-A transmit data                              |                               |                              |
| Bmode_pin3               |                | I  | Boot mode pin 3                                  |                               |                              |
| PF4_GPIO36               | 48             | I/O/Z                                    | General-purpose input/output 36                  | PU                            | 4 mA                         |
| M_CCP0                   |                | I/O                                      | Capture/Compare/PWM-0<br>(General-purpose Timer) |                               |                              |
| M_MIIMDIO                |                | I/O                                      | EMAC management data input/output                |                               |                              |
| M_EPI0S12                |                | I/O                                      | EPI-0 signal 12                                  |                               |                              |
| M_SSI1RX                 |                | I  | SSI-1 receive data                               |                               |                              |
| M_U0RX                   |                | I  | UART-0 receive data                              |                               |                              |
| C_SCIRXDA                |                | I  | SCI-A receive data                               |                               |                              |

Table 4-1. Signal Descriptions<sup>(1)</sup> (continued)

| TERMINAL                 |             | I/O/Z <sup>(2)</sup> | DESCRIPTION   | PU or PD <sup>(3)</sup> | OUTPUT BUFFER STRENGTH |
|--------------------------|-------------|----------------------|---|-------------------------|------------------------|
| NAME                     | RFP PIN NO. |                      |   |                         |                        |
| PF5_GPIO37               | 51          | I/O/Z                | General-purpose input/output 37   | PU                      | 4 mA                   |
| M_CCP2                   |             | I/O                  | Capture/Compare/PWM-2 (General-purpose Timer)   |                         |                        |
| M_MIIRXD3                |             | I                    | EMAC MII receive data 3   |                         |                        |
| M_EPI0S15                |             | I/O                  | EPI-0 signal 15   |                         |                        |
| M_SSI1TX                 |             | O                    | SSI-1 transmit data   |                         |                        |
| C_ECAP2                  |             | I/O                  | Enhanced Capture-2 input/output   |                         |                        |
| PF6_GPIO38               | 69          | I/O/Z                | General-purpose input/output 38. If configured as an output, place a capacitor with a value of 56 pF or greater near the pin. If configured as an input, place a series resistor with a value equal to 1 kΩ or greater near the pin. See the <a href="#">F28M35x Concerto™ MCUs Silicon Errata</a> for details.<br><b>NOTE:</b> For this pin, only the USB0VBUS function is available on silicon revision 0 devices (GPIO and the four other functions listed are not available). | PU                      | 4 mA                   |
| M_USB0VBUS               |             | Analog               | USB0 VBUS power (5-V tolerant)  |                         |                        |
| M_CCP1                   |             | I/O                  | Capture/Compare/PWM-1 (General-purpose Timer)   |                         |                        |
| M_MIIRXD2                |             | I                    | EMAC MII receive data 2   |                         |                        |
| M_EPI0S38 <sup>(5)</sup> |             | I/O                  | EPI-0 signal 38   |                         |                        |
| PF7_GPIO39               | No Pin      | No Pin               | General-purpose input/output 39 is not pinned out.  |                         |                        |
| PG0_GPIO40               | 49          | I/O/Z                | General-purpose input/output 40   | PU                      | 4 mA                   |
| M_U2RX                   |             | I                    | UART-2 receive data   |                         |                        |
| M_I2C1SCL                |             | I/OD                 | I2C-1 clock open-drain bidirectional port   |                         |                        |
| M_USB0EPEN               |             | O                    | USB-0 external power enable (optionally used in the host mode)  |                         |                        |
| M_EPI0S13                |             | I/O                  | EPI-0 signal 13   |                         |                        |
| M_MIIRXD2                |             | I                    | EMAC MII receive data 2   |                         |                        |
| M_U4RX                   |             | I                    | UART-4 receive data   |                         |                        |
| PG1_GPIO41               | 50          | I/O/Z                | General-purpose input/output 41   | PU                      | 4 mA                   |
| M_U2TX                   |             | O                    | UART-2 transmit data  |                         |                        |
| M_I2C1SDA                |             | I/OD                 | I2C-1 data open-drain bidirectional port  |                         |                        |
| M_EPI0S14                |             | I/O                  | EPI-0 signal 14   |                         |                        |
| M_MIIRXD1                |             | I                    | EMAC MII receive data 1   |                         |                        |
| M_U4TX                   |             | O                    | UART-4 transmit data  |                         |                        |
| PG2_GPIO42               | 71          | I/O/Z                | General-purpose input/output 42   | PU                      | 4 mA                   |
| M_USB0DM                 |             | Analog               | USB0 data minus   |                         |                        |
| M_MIICOL                 |             | I                    | EMAC MII collision detect   |                         |                        |
| M_EPI0S39 <sup>(5)</sup> |             | I/O                  | EPI-0 signal 39   |                         |                        |
| PG3_GPIO43               | 78          | I/O/Z                | General-purpose input/output 43   | PU                      | 4 mA                   |
| M_MIICRS                 |             | I                    | EMAC MII carrier sense  |                         |                        |
| M_MIIRXDV                |             | I                    | EMAC MII receive data valid   |                         |                        |
| M_TRACED1                |             | O                    | Trace data 1  |                         |                        |
| Bmode_pin1               |             | I                    | Boot mode pin 1   |                         |                        |
| PG4_GPIO44               | No Pin      | No Pin               | General-purpose input/output 44 is not pinned out.  |                         |                        |

**Table 4-1. Signal Descriptions<sup>(1)</sup> (continued)**

| TERMINAL                 |             | I/O/Z <sup>(2)</sup> | DESCRIPTION  | PU or PD <sup>(3)</sup> | OUTPUT BUFFER STRENGTH |
|--------------------------|-------------|----------------------|--|-------------------------|------------------------|
| NAME                     | RFP PIN NO. |                      |  |                         |                        |
| PG5_GPIO45               | 72          | I/O/Z                | General-purpose input/output 45  | PU                      | 4 mA                   |
| M_USB0DP                 |             | Analog               | USB0 data plus   |                         |                        |
| M_CCP5                   |             | I/O                  | Capture/Compare/PWM-5 (General-purpose Timer)  |                         |                        |
| M_MIITXEN                |             | O                    | EMAC MII transmit enable   |                         |                        |
| M_EPI0S40 <sup>(5)</sup> |             | I/O                  | EPI-0 signal 40  |                         |                        |
| PG6_GPIO46               | 70          | I/O/Z                | General-purpose input/output 46. If configured as an output, place a capacitor with a value of 56 pF or greater near the pin. If configured as an input, place a series resistor with a value equal to 1 kΩ or greater near the pin. See the <a href="#">F28M35x Concerto™ MCUs Silicon Errata</a> for details.<br><b>NOTE:</b> For this pin, only the USB0ID function is available on silicon revision 0 devices (GPIO and the three other functions listed are not available). | PU                      | 4 mA                   |
| M_USB0ID                 |             | Analog               | USB0 ID (5-V tolerant)   |                         |                        |
| M_MIITXCK                |             | I                    | EMAC MII transmit clock  |                         |                        |
| M_EPI0S41 <sup>(5)</sup> |             | I/O                  | EPI-0 signal 41  |                         |                        |
| PG7_GPIO47               | 52          | I/O/Z                | General-purpose input/output 47  | PU                      | 6 mA                   |
| M_MIITXER                |             | O                    | EMAC MII transmit error  |                         |                        |
| M_CCP5                   |             | I/O                  | Capture/Compare/PWM-5 (General-purpose Timer)  |                         |                        |
| M_EPI0S31                |             | I/O                  | EPI-0 signal 31  |                         |                        |
| Bmode_pin2               |             | I                    | Boot mode pin 2  |                         |                        |
| PH0_GPIO48               | 41          | I/O/Z                | General-purpose input/output 48  | PU                      | 4 mA                   |
| M_CCP6                   |             | I/O                  | Capture/Compare/PWM-6 (General-purpose Timer)  |                         |                        |
| M_MIIPHYRST              |             | O                    | EMAC PHY MII reset   |                         |                        |
| M_EPI0S6                 |             | I/O                  | EPI-0 signal 6   |                         |                        |
| M_SSI3TX                 |             | O                    | SSI-3 transmit data  |                         |                        |
| C_ECAP5                  |             | I/O                  | Enhanced Capture-5 input/output  |                         |                        |
| PH1_GPIO49               | 42          | I/O/Z                | General-purpose input/output 49  | PU                      | 4 mA                   |
| M_CCP7                   |             | I/O                  | Capture/Compare/PWM-7 (General-purpose Timer)  |                         |                        |
| M_EPI0S7                 |             | I/O                  | EPI-0 signal 7   |                         |                        |
| M_MIIRXD0                |             | I                    | EMAC MII receive data 0  |                         |                        |
| M_SSI3RX                 |             | I                    | SSI-3 receive data   |                         |                        |
| C_ECAP6                  |             | I/O                  | Enhanced Capture-6 input/output  |                         |                        |
| PH2_GPIO50               | 36          | I/O/Z                | General-purpose input/output 50  | PU                      | 4 mA                   |
| M_EPI0S1                 |             | I/O                  | EPI-0 signal 1   |                         |                        |
| M_MIITXD3                |             | O                    | EMAC MII transmit data 3   |                         |                        |
| M_SSI3CLK                |             | I/O                  | SSI-3 clock  |                         |                        |
| C_EQEP1A                 |             | I                    | Enhanced QEP-1 input A   |                         |                        |
| PH3_GPIO51               | 35          | I/O/Z                | General-purpose input/output 51  | PU                      | 4 mA                   |
| M_USB0EPEN               |             | O                    | USB-0 external power enable (optionally used in the host mode)   |                         |                        |
| M_EPI0S0                 |             | I/O                  | EPI-0 signal 0   |                         |                        |
| M_MIITXD2                |             | O                    | EMAC MII transmit data 2   |                         |                        |
| M_SSI3FSS                |             | I/O                  | SSI-3 frame  |                         |                        |
| C_EQEP1B                 |             | I                    | Enhanced QEP-1 input B   |                         |                        |

**Table 4-1. Signal Descriptions<sup>(1)</sup> (continued)**

| TERMINAL   |             | I/O/Z <sup>(2)</sup> | DESCRIPTION   | PU or PD <sup>(3)</sup> | OUTPUT BUFFER STRENGTH |
|------------|-------------|----------------------|---|-------------------------|------------------------|
| NAME       | RFP PIN NO. |                      |   |                         |                        |
| PH4_GPIO52 | 46          | I/O/Z                | General-purpose input/output 52                                     | PU                      | 4 mA                   |
| M_USB0PFLT |             | I                    | USB-0 external power error state (optionally used in the host mode) |                         |                        |
| M_EPI0S10  |             | I/O                  | EPI-0 signal 10   |                         |                        |
| M_MIITXD1  |             | O                    | EMAC MII transmit data 1  |                         |                        |
| M_SSI1CLK  |             | I/O                  | SSI-1 clock   |                         |                        |
| M_U3TX     |             | O                    | UART-3 transmit data  |                         |                        |
| C_EQEP1S   |             | I/O                  | Enhanced QEP-1 strobe   |                         |                        |
| PH5_GPIO53 | 47          | I/O/Z                | General-purpose input/output 53                                     | PU                      | 4 mA                   |
| M_EPI0S11  |             | I/O                  | EPI-0 signal 11   |                         |                        |
| M_MIITXD0  |             | O                    | EMAC MII transmit data 0  |                         |                        |
| M_SSI1FSS  |             | I/O                  | SSI-1 frame   |                         |                        |
| M_U3RX     |             | I                    | UART-3 receive data   |                         |                        |
| C_EQEP1I   |             | I/O                  | Enhanced QEP-1 index  |                         |                        |
| PH6_GPIO54 | 79          | I/O/Z                | General-purpose input/output 54                                     | PU                      | 4 mA                   |
| M_EPI0S26  |             | I/O                  | EPI-0 signal 26   |                         |                        |
| M_MIIRXDV  |             | I                    | EMAC MII receive data valid   |                         |                        |
| M_SSI1RX   |             | I                    | SSI-1 receive data  |                         |                        |
| M_MIITXEN  |             | O                    | EMAC MII transmit enable  |                         |                        |
| M_SSI0TX   |             | O                    | SSI-0 transmit data   |                         |                        |
| C_SPISIMOA |             | I/O                  | SPI-A slave in, master out  |                         |                        |
| C_EQEP3A   |             | I                    | Enhanced QEP-1 input A  |                         |                        |
| PH7_GPIO55 | 80          | I/O/Z                | General-purpose input/output 55                                     | PU                      | 4 mA                   |
| M_MIIRXCK  |             | I                    | EMAC MII receive clock  |                         |                        |
| M_EPI0S27  |             | I/O                  | EPI-0 signal 27   |                         |                        |
| M_SSI1TX   |             | O                    | SSI-1 transmit data   |                         |                        |
| M_MIITXCK  |             | I                    | EMAC MII transmit clock   |                         |                        |
| M_SSI0RX   |             | I                    | SSI-0 receive data  |                         |                        |
| C_SPISOMIA |             | I/O                  | SPI-A master in, slave out  |                         |                        |
| C_EQEP3B   |             | I                    | Enhanced QEP-3 input B  |                         |                        |
| PJ0_GPIO56 | 63          | I/O/Z                | General-purpose input/output 56                                     | PU                      | 4 mA                   |
| M_MIIRXER  |             | I                    | EMAC MII receive error  |                         |                        |
| M_EPI0S16  |             | I/O                  | EPI-0 signal 16   |                         |                        |
| M_I2C1SCL  |             | I/OD                 | I2C-1 clock open-drain bidirectional port                           |                         |                        |
| M_SSI0CLK  |             | I/O                  | SSI-0 clock   |                         |                        |
| C_SPICLKA  |             | I/O                  | SPI-A clock   |                         |                        |
| C_EQEP3S   |             | I/O                  | Enhanced QEP-3 strobe   |                         |                        |
| PJ1_GPIO57 | 62          | I/O/Z                | General-purpose input/output 57                                     | PU                      | 4 mA                   |
| M_EPI0S17  |             | I/O                  | EPI-0 signal 17   |                         |                        |
| M_USB0PFLT |             | I                    | USB-0 external power error state (optionally used in the host mode) |                         |                        |
| M_I2C1SDA  |             | I/OD                 | I2C-1 data open-drain bidirectional port                            |                         |                        |
| M_MIIRXDV  |             | I                    | EMAC MII receive data valid   |                         |                        |
| M_SSI0FSS  |             | I/O                  | SSI-0 frame   |                         |                        |
| C_SPISTEA  |             | I/O                  | SPI-A slave transmit enable   |                         |                        |
| C_EQEP3I   |             | I/O                  | Enhanced QEP-3 index  |                         |                        |

**Table 4-1. Signal Descriptions<sup>(1)</sup> (continued)**

| TERMINAL     |                | I/O/Z <sup>(2)</sup> | DESCRIPTION  | PU<br>or<br>PD <sup>(3)</sup> | OUTPUT<br>BUFFER<br>STRENGTH |
|--------------|----------------|----------------------|--|-------------------------------|------------------------------|
| NAME         | RFP<br>PIN NO. |                      |  |                               |                              |
| PJ2_GPIO58   | 61             | I/O/Z                | General-purpose input/output 58                    | PU                            | 4 mA                         |
| M_EPI0S18    |                | I/O                  | EPI-0 signal 18                                    |                               |                              |
| M_CCP0       |                | I/O                  | Capture/Compare/PWM-0<br>(General-purpose Timer)   |                               |                              |
| M_MIIRXCK    |                | I                    | EMAC MII receive clock                             |                               |                              |
| M_SSI0CLK    |                | I/O                  | SSI-0 clock  |                               |                              |
| M_U0TX       |                | O                    | UART-0 transmit data                               |                               |                              |
| C_MCLKRA     |                | I                    | McBSP-A receive clock                              |                               |                              |
| C_EPWM7A     |                | O                    | Enhanced PWM-7 output A                            |                               |                              |
| PJ3_GPIO59   | 60             | I/O/Z                | General-purpose input/output 59                    | PU                            | 4 mA                         |
| M_EPI0S19    |                | I/O                  | EPI-0 signal 19                                    |                               |                              |
| M_CCP6       |                | I/O                  | Capture/Compare/PWM-6<br>(General-purpose Timer)   |                               |                              |
| M_MIIMDC     |                | O                    | EMAC management data clock                         |                               |                              |
| M_SSI0FSS    |                | I/O                  | SSI-0 frame  |                               |                              |
| M_U0RX       |                | I                    | UART-0 receive data                                |                               |                              |
| C_MFSRA      |                | I                    | McBSP-A receive frame sync                         |                               |                              |
| C_EPWM7B     |                | O                    | Enhanced PWM-7 output B                            |                               |                              |
| PJ4_GPIO60   | 57             | I/O/Z                | General-purpose input/output 60                    | PU                            | 6 mA                         |
| M_EPI0S28    |                | I/O                  | EPI-0 signal 28                                    |                               |                              |
| M_CCP4       |                | I/O                  | Capture/Compare/PWM-4<br>(General-purpose Timer)   |                               |                              |
| M_MIICOL     |                | I                    | EMAC MII collision detect                          |                               |                              |
| M_SSI1CLK    |                | I/O                  | SSI-1 clock  |                               |                              |
| C_EPWM8A     |                | O                    | Enhanced PWM-8 output A                            |                               |                              |
| PJ5_GPIO61   | 56             | I/O/Z                | General-purpose input/output 61                    | PU                            | 6 mA                         |
| M_EPI0S29    |                | I/O                  | EPI-0 signal 29                                    |                               |                              |
| M_CCP2       |                | I/O                  | Capture/Compare/PWM-2<br>(General-purpose Timer)   |                               |                              |
| M_MIICRS     |                | I                    | EMAC MII carrier sense                             |                               |                              |
| M_SSI1FSS    |                | I/O                  | SSI-1 frame  |                               |                              |
| C_EPWM8B     |                | O                    | Enhanced PWM-8 output B                            |                               |                              |
| PJ6_GPIO62   | 53             | I/O/Z                | General-purpose input/output 62                    | PU                            | 6 mA                         |
| M_EPI0S30    |                | I/O                  | EPI-0 signal 30                                    |                               |                              |
| M_CCP1       |                | I/O                  | Capture/Compare/PWM-1<br>(General-purpose Timer)   |                               |                              |
| M_MIIPHYINTR |                | I                    | EMAC PHY MII interrupt                             |                               |                              |
| M_U2RX       |                | I                    | UART-2 receive data                                |                               |                              |
| C_EPWM9A     |                | O                    | Enhanced PWM-9 output A                            |                               |                              |
| PJ7_GPIO63   | 97             | I/O/Z                | General-purpose input/output 63                    | PU                            | 4 mA                         |
| M_CCP0       |                | I/O                  | Capture/Compare/PWM-0<br>(General-purpose Timer)   |                               |                              |
| M_MIIPHYRST  |                | O                    | EMAC PHY MII reset                                 |                               |                              |
| M_U2TX       |                | O                    | UART-2 transmit data                               |                               |                              |
| C_EPWM9B     |                | O                    | Enhanced PWM-9 output B                            |                               |                              |
| PC0_GPIO64   |                | No Pin               | No Pin   |                               |                              |
| PC1_GPIO65   | No Pin         | No Pin               | General-purpose input/output 65 is not pinned out. |                               |                              |

**Table 4-1. Signal Descriptions<sup>(1)</sup> (continued)**

| TERMINAL   |             | I/O/Z <sup>(2)</sup>                          | DESCRIPTION   | PU or PD <sup>(3)</sup> | OUTPUT BUFFER STRENGTH |
|------------|-------------|---|---|-------------------------|------------------------|
| NAME       | RFP PIN NO. |   |   |                         |                        |
| PC2_GPIO66 | No Pin      | No Pin  | General-purpose input/output 66 is not pinned out.                  |                         |                        |
| PC3_GPIO67 | No Pin      | No Pin  | General-purpose input/output 67 is not pinned out.                  |                         |                        |
| PC4_GPIO68 | 37          | I/O/Z   | General-purpose input/output 68                                     | PU                      | 4 mA                   |
| M_CCP5     |             | I   | Capture/Compare/PWM-5 (General-purpose Timer)                       |                         |                        |
| M_MIITXD3  |             | O   | EMAC MII transmit data 3  |                         |                        |
| M_CCP2     |             | I   | Capture/Compare/PWM-2 (General-purpose Timer)                       |                         |                        |
| M_CCP4     |             | I   | Capture/Compare/PWM-4 (General-purpose Timer)                       |                         |                        |
| M_EPI0S2   |             | I/O   | EPI-0 signal 2  |                         |                        |
| M_CCP1     | I           | Capture/Compare/PWM-1 (General-purpose Timer) |   |                         |                        |
| PC5_GPIO69 | 38          | I/O/Z   | General-purpose input/output 69                                     | PU                      | 4 mA                   |
| M_CCP1     |             | I   | Capture/Compare/PWM-1 (General-purpose Timer)                       |                         |                        |
| M_CCP3     |             | I   | Capture/Compare/PWM-3 (General-purpose Timer)                       |                         |                        |
| M_USB0EPEN |             | O   | USB-0 external power enable (optionally used in the host mode)      |                         |                        |
| M_EPI0S3   |             | I/O   | EPI-0 signal 3  |                         |                        |
| PC6_GPIO70 | 39          | I/O/Z   | General-purpose input/output 70                                     | PU                      | 4 mA                   |
| M_CCP3     |             | I   | Capture/Compare/PWM-3 (General-purpose Timer)                       |                         |                        |
| M_U1RX     |             | I   | UART-1 receive data   |                         |                        |
| M_CCP0     |             | I   | Capture/Compare/PWM-0 (General-purpose Timer)                       |                         |                        |
| M_USB0PFLT |             | I   | USB-0 external power error state (optionally used in the host mode) |                         |                        |
| M_EPI0S4   | I/O         | EPI-0 signal 4                                |   |                         |                        |
| PC7_GPIO71 | 40          | I/O/Z   | General-purpose input/output 71                                     | PU                      | 4 mA                   |
| M_CCP4     |             | I   | Capture/Compare/PWM-4 (General-purpose Timer)                       |                         |                        |
| M_CCP0     |             | I   | Capture/Compare/PWM-0 (General-purpose Timer)                       |                         |                        |
| M_U1TX     |             | O   | UART-1 transmit data  |                         |                        |
| M_USB0PFLT |             | I   | USB-0 external power error state (optionally used in the host mode) |                         |                        |
| M_EPI0S5   |             | I/O   | EPI-0 signal 5  |                         |                        |

**Table 4-1. Signal Descriptions<sup>(1)</sup> (continued)**

| TERMINAL                |                | I/O/Z <sup>(2)</sup> | DESCRIPTION   | PU<br>or<br>PD <sup>(3)</sup> | OUTPUT<br>BUFFER<br>STRENGTH |
|-------------------------|----------------|----------------------|---|-------------------------------|------------------------------|
| NAME                    | RFP<br>PIN NO. |                      |   |                               |                              |
| <b>Resets</b>           |                |                      |   |                               |                              |
| $\overline{\text{XRS}}$ | 4              | I/OD                 | Digital Subsystem Reset (in) and Watchdog/Power-on Reset (out). In most applications, TI recommends that the $\overline{\text{XRS}}$ pin be tied with the $\overline{\text{ARS}}$ pin. The Digital Subsystem has a built-in POR circuit, and during a power-on condition, this pin is driven low by the Digital Subsystem. This pin is also driven low by the Digital Subsystem when a watchdog reset occurs. During watchdog reset, the $\overline{\text{XRS}}$ pin is driven low for the watchdog reset duration of 512 OSCCLK cycles. If needed, an external circuitry may also drive this pin to assert device reset. In this case, TI recommends that this pin be driven by an open-drain device. A noise filtering circuit can be connected to this pin. A resistor with a value from 2.2 k $\Omega$ to 10 k $\Omega$ should be placed between $\overline{\text{XRS}}$ and $V_{\text{DDIO}}$ . If a capacitor is placed between $\overline{\text{XRS}}$ and $V_{\text{SS}}$ for noise filtering, it should be 100 nF or smaller. These values will allow the watchdog to properly drive the $\overline{\text{XRS}}$ pin to $V_{\text{OL}}$ within 512 OSCCLK cycles when the watchdog reset is asserted. Regardless of the source, a device reset causes the Digital Subsystem to terminate execution. The Cortex-M3 program counter points to the address contained at the location 0x00000004. The C28 program counter points to the address contained at the location 0x3FFFC0. When reset is deactivated, execution begins at the location designated by the program counter. The output buffer of this pin is an open-drain with an internal pullup. | PU                            | 4 mA                         |
| $\overline{\text{ARS}}$ | 144            | I/OD                 | Analog Subsystem Reset (in) and Power-on Reset (out). TI recommends that the $\overline{\text{ARS}}$ pin be tied with the $\overline{\text{XRS}}$ pin. The Analog Subsystem has a built-in POR circuit, and during a power-on condition, this pin is driven low by the Analog Subsystem. If needed, an external circuitry may also drive this pin to assert a device reset. In this case, TI recommends that this pin be driven by an open-drain device. Regardless of the source, the Analog Subsystem reset causes the digital logic associated with the Analog Subsystem, to enter reset state. The output buffer of this pin is an open-drain with an internal pullup.  | PU                            | 4 mA                         |

Table 4-1. Signal Descriptions<sup>(1)</sup> (continued)

| TERMINAL                 |                   | I/O/Z <sup>(2)</sup> | DESCRIPTION   | PU<br>or<br>PD <sup>(3)</sup> | OUTPUT<br>BUFFER<br>STRENGTH |
|--------------------------|-------------------|----------------------|---|-------------------------------|------------------------------|
| NAME                     | RFP<br>PIN NO.    |                      |   |                               |                              |
| <b>Clocks</b>            |                   |                      |   |                               |                              |
| X1                       | 93                | I                    | External oscillator input or on-chip crystal-oscillator input. To use the on-chip oscillator, a quartz crystal or a ceramic resonator must be connected across X1 and X2. See <a href="#">Figure 6-7</a> .  |                               |                              |
| X2                       | 95                | O                    | On-chip crystal-oscillator output. A quartz crystal or a ceramic resonator must be connected across X1 and X2. If X2 is not used, it must be left unconnected. See <a href="#">Figure 6-7</a> .   |                               |                              |
| V <sub>SSOSC</sub>       | 94                |                      | Clock Oscillator Ground Pin. Use this pin to connect the GND of external crystal load capacitors or the ground pin of 3-terminal ceramic resonators with built-in capacitors. <b>Do not</b> connect to board ground. See <a href="#">Figure 6-7</a> .   |                               |                              |
| XCLKIN                   | see<br>PJ7_GPIO63 | I                    | External oscillator input. This pin feeds a clock from an external 3.3-V oscillator to internal USB PLL module and to the CAN peripherals.  |                               |                              |
| XCLKOUT                  | see<br>PF2_GPIO34 | O/Z                  | External oscillator output. This pin outputs a clock divided-down from the internal PLL System Clock. The divide ratio is defined in the XPLLCLKCFG register.   |                               |                              |
| <b>Boot Pins</b>         |                   |                      |   |                               |                              |
| Bmode_pin1               | see<br>PG3_GPIO43 | I                    | One of four boot mode pins. Bmode_pin1 selects a specific configuration source from which the Concerto device boots on start-up.  | PU                            |                              |
| Bmode_pin2               | see<br>PG7_GPIO47 | I                    | One of four boot mode pins. Bmode_pin2 selects a specific configuration source from which the Concerto device boots on start-up.  | PU                            |                              |
| Bmode_pin3               | see<br>PF3_GPIO35 | I                    | One of four boot mode pins. Bmode_pin3 selects a specific configuration source from which the Concerto device boots on start-up.  | PU                            |                              |
| Bmode_pin4               | see<br>PF2_GPIO34 | I                    | One of four boot mode pins. Bmode_pin4 selects a specific configuration source from which the Concerto device boots on start-up.  | PU                            |                              |
| <b>JTAG</b>              |                   |                      |   |                               |                              |
| $\overline{\text{TRST}}$ | 85                | I                    | JTAG test reset with internal pulldown. $\overline{\text{TRST}}$ , when driven high, gives the scan system control of the operations of the device. If this signal is not connected or driven low, the device operates in its functional mode, and the test reset signals are ignored. <b>NOTE:</b> $\overline{\text{TRST}}$ is an active-low test pin and must be maintained low during normal device operation. An external pulldown resistor is required on this pin. The value of this resistor should be based on drive strength of the debugger pods applicable to the design. A 2.2-k $\Omega$ resistor generally offers adequate protection. Because the value of the resistor is application-specific, TI recommends that each target board be validated for proper operation of the debugger and the application. | PD                            |                              |
| TCK                      | 89                | I                    | JTAG test clock   |                               |                              |
| TMS                      | 87                | I                    | JTAG test-mode select (TMS) with internal pullup. This serial control input is clocked into the TAP controller on the rising edge of TCK.   | PU                            |                              |
| TDI                      | 88                | I                    | JTAG test data input (TDI) with internal pullup. TDI is clocked into the selected register (instruction or data) on a rising edge of TCK.   | PU                            |                              |

**Table 4-1. Signal Descriptions<sup>(1)</sup> (continued)**

| TERMINAL   |                   | I/O/Z <sup>(2)</sup> | DESCRIPTION  | PU<br>or<br>PD <sup>(3)</sup> | OUTPUT<br>BUFFER<br>STRENGTH |
|--|-------------------|----------------------|--|-------------------------------|------------------------------|
| NAME   | RFP<br>PIN NO.    |                      |  |                               |                              |
| TDO  | 84                | O                    | JTAG scan out, test data output (TDO). The contents of the selected register (instruction or data) are shifted out of TDO on the falling edge of TCK.  |                               | 4 mA                         |
| EMU0   | 83                | I/O/Z                | <p>Emulator pin 0. When <math>\overline{\text{TRST}}</math> is driven high, this pin is used as an interrupt to or from the emulator system and is defined as input/output through the JTAG scan. This pin is also used to put the device into boundary-scan mode. With the EMU0 pin at a logic-high state and the EMU1 pin at a logic-low state, a rising edge on the <math>\overline{\text{TRST}}</math> pin would latch the device into boundary-scan mode.</p> <p><b>NOTE:</b> An external pullup resistor is required on this pin. The value of this resistor should be based on the drive strength of the debugger pods applicable to the design. A 2.2-k<math>\Omega</math> to 4.7-k<math>\Omega</math> resistor is generally adequate. Because the value of the resistor is application-specific, TI recommends that each target board be validated for proper operation of the debugger and the application.</p> <p><b>NOTE:</b> If EMU0 is 0 and EMU1 is 1 when coming out of reset, the device enters Wait-in-Reset mode. WIR suspends bootloader execution, allowing the Emulator to connect to the device and to modify FLASH contents.</p> | PU                            | 4 mA                         |
| EMU1   | 86                | I/O/Z                | <p>Emulator pin 1. When <math>\overline{\text{TRST}}</math> is driven high, this pin is used as an interrupt to or from the emulator system and is defined as input/output through the JTAG scan. This pin is also used to put the device into boundary-scan mode. With the EMU0 pin at a logic-high state and the EMU1 pin at a logic-low state, a rising edge on the <math>\overline{\text{TRST}}</math> pin would latch the device into boundary-scan mode.</p> <p><b>NOTE:</b> An external pullup resistor is required on this pin. The value of this resistor should be based on the drive strength of the debugger pods applicable to the design. A 2.2-k<math>\Omega</math> to 4.7-k<math>\Omega</math> resistor is generally adequate. Because the value of the resistor is application-specific, TI recommends that each target board be validated for proper operation of the debugger and the application.</p> <p><b>NOTE:</b> If EMU0 is 0 and EMU1 is 1 when coming out of reset, the device enters Wait-in-Reset mode. WIR suspends bootloader execution, allowing the Emulator to connect to the device and to modify FLASH contents.</p> | PU                            | 4 mA                         |
| <b>ITM Trace (ARM Instrumentation Trace Macrocell)</b> |                   |                      |  |                               |                              |
| TRACED0  | see<br>PF3_GPIO35 | O                    | ITM Trace data 0   |                               | 4 mA                         |
| TRACED1  | see<br>PG3_GPIO43 | O                    | ITM Trace data 1   |                               | 4 mA                         |
| TRACED2  | see<br>PF0_GPIO32 | O                    | ITM Trace data 2   |                               | 4 mA                         |
| TRACED3  | see<br>PF1_GPIO33 | O                    | ITM Trace data 3   |                               | 4 mA                         |
| TRACECLK   | see<br>PF2_GPIO34 | O                    | ITM Trace clock  |                               | 4 mA                         |

**Table 4-1. Signal Descriptions<sup>(1)</sup> (continued)**

| TERMINAL   |             | I/O/Z <sup>(2)</sup> | DESCRIPTION   | PU or PD <sup>(3)</sup> | OUTPUT BUFFER STRENGTH |
|--|-------------|----------------------|---|-------------------------|------------------------|
| NAME   | RFP PIN NO. |                      |   |                         |                        |
| <b>Test Pins</b>   |             |                      |   |                         |                        |
| FLT1   | 16          | I/O                  | FLASH Test Pin 1. Reserved for TI. Must be left unconnected.  |                         |                        |
| FLT2   | 21          | I/O                  | FLASH Test Pin 2. Reserved for TI. Must be left unconnected.  |                         |                        |
| <b>Internal Voltage Regulator Control</b>                                      |             |                      |   |                         |                        |
| $\overline{\text{VREG18EN}}$   | 113         |                      | Internal 1.8-V VREG Enable/Disable for $V_{DD18}$ . Pull low to enable the internal 1.8-V voltage regulator (VREG18), pull high to disable VREG18.  | PD                      |                        |
| $\overline{\text{VREG12EN}}$   | 101         |                      | Internal 1.2-V VREG Enable/Disable for $V_{DD12}$ . Pull low to enable the internal 1.2-V voltage regulator (VREG12), pull high to disable VREG12.  | PD                      |                        |
| <b>Digital Logic Power Pins for I/Os, Flash, USB, and Internal Oscillators</b> |             |                      |   |                         |                        |
| $V_{DDIO}$   | 107         |                      | 3.3-V Digital I/O and FLASH Power Pin. Tie with a 0.1- $\mu$ F capacitor (typical) close to the pin. When the 1.2-V VREG is enabled (by pulling the $\overline{\text{VREG12EN}}$ pin low), these pins also supply power to the Digital Subsystem. When the 1.8-V VREG is enabled (by pulling the $\overline{\text{VREG18EN}}$ pin low), these pins also supply power to the Analog Subsystem. |                         |                        |
| $V_{DDIO}$   | 10          |                      |   |                         |                        |
| $V_{DDIO}$   | 25          |                      |   |                         |                        |
| $V_{DDIO}$   | 34          |                      |   |                         |                        |
| $V_{DDIO}$   | 44          |                      |   |                         |                        |
| $V_{DDIO}$   | 54          |                      |   |                         |                        |
| $V_{DDIO}$   | 59          |                      |   |                         |                        |
| $V_{DDIO}$   | 105         |                      |   |                         |                        |
| $V_{DDIO}$   | 3           |                      |   |                         |                        |
| $V_{DDIO}$   | 67          |                      |   |                         |                        |
| $V_{DDIO}$   | 74          |                      |   |                         |                        |
| $V_{DDIO}$   | 92          |                      |   |                         |                        |
| $V_{DDIO}$   | 100         |                      |   |                         |                        |
| $V_{DDIO}$   | 96          |                      |   |                         |                        |
| $V_{DDIO}$   | 17          |                      |   |                         |                        |
| $V_{DDIO}$   | 2           |                      |   |                         |                        |
| $V_{DDIO}$   | 106         |                      |   |                         |                        |
| <b>Digital Logic Power Pins (Analog Subsystem)</b>                             |             |                      |   |                         |                        |
| $V_{DD18}$   | 1           |                      | 1.8-V Digital Logic Power Pins (associated with the Analog Subsystem) - no supply needed when using internal VREG18. Tie with 1.2- $\mu$ F (minimum) ceramic capacitor (10% tolerance) to ground when using internal VREG. Higher value capacitors may be used but could impact supply-rail ramp-up time.   |                         |                        |
| $V_{DD18}$   | 108         |                      |   |                         |                        |

**Table 4-1. Signal Descriptions<sup>(1)</sup> (continued)**

| TERMINAL   |                | I/O/Z <sup>(2)</sup> | DESCRIPTION  | PU<br>or<br>PD <sup>(3)</sup> | OUTPUT<br>BUFFER<br>STRENGTH |
|--|----------------|----------------------|--|-------------------------------|------------------------------|
| NAME   | RFP<br>PIN NO. |                      |  |                               |                              |
| <b>Digital Logic Power Pins (Master and Control Subsystems)</b>      |                |                      |  |                               |                              |
| V <sub>DD12</sub>  | 24             |                      | 1.2-V Digital Logic Power Pins - no supply needed when using internal VREG12. Tie with 250-nF (minimum) to 750-nF (maximum) ceramic capacitor (10% tolerance) to ground when using internal VREG. Higher value capacitors may be used but could impact supply-rail ramp-up time. |                               |                              |
| V <sub>DD12</sub>  | 55             |                      |  |                               |                              |
| V <sub>DD12</sub>  | 66             |                      |  |                               |                              |
| V <sub>DD12</sub>  | 99             |                      |  |                               |                              |
| V <sub>DD12</sub>  | 75             |                      |  |                               |                              |
| V <sub>DD12</sub>  | 58             |                      |  |                               |                              |
| V <sub>DD12</sub>  | 11             |                      |  |                               |                              |
| V <sub>DD12</sub>  | 90             |                      |  |                               |                              |
| <b>Digital Logic Ground (Analog, Master, and Control Subsystems)</b> |                |                      |  |                               |                              |
| V <sub>SS</sub>  | PWR PAD        |                      | Digital Ground Power Pad (located on the bottom of the chip)   |                               |                              |
| <b>No Connect Pins</b>   |                |                      |  |                               |                              |
| NC   | 91             |                      | This pin is a "no connect" (that is, this pin is not connected to any circuitry internal to the device).   |                               |                              |

(1) Throughout this table, Master Subsystem signals are denoted by the color blue; Control Subsystem signals are denoted by the color green; and Analog Subsystem signals are denoted by the color orange.

(2) I = Input, O = Output, Z = High Impedance, OD = Open Drain

(3) PU = Pullup, PD = Pulldown

- GPIO\_MUX1 pullups can be enabled or disabled by Cortex-M3 software (disabled on reset).
- GPIO\_MUX2 pullups can be enabled or disabled by C28x software (disabled on reset).
- AIO\_MUX1 and AIO\_MUX2 terminals do not have pullups or pulldowns.
- All other pullups are always enabled (XRS, ARS, TMS, TDI, EMU0, EMU1).
- All pulldowns are always enabled (VREG18EN, VREG12EN, TRST).

(4) All I/Os, except for GPIO135, are glitch-free during power up and power down. See [Section 6.11](#).

(5) This muxing option is only available on silicon Revision A devices; this muxing option is not available on silicon Revision 0 devices.

(6) Output from the Concerto ePWM is meant for the external ADC (if present).

## 5 Specifications

### 5.1 Absolute Maximum Ratings<sup>(1)(2)</sup>

over operating free-air temperature range (unless otherwise noted)

|                                     |  | MIN  | MAX             | UNIT |
|-------------------------------------|--|------|-----------------|------|
| Supply voltage                      | V <sub>DDIO</sub> (I/O and Flash) with respect to V <sub>SS</sub>  | -0.3 | 4.6             | V    |
|                                     | V <sub>DD18</sub> with respect to V <sub>SS</sub>  | -0.3 | 2.5             |      |
|                                     | V <sub>DD12</sub> with respect to V <sub>SS</sub>  | -0.3 | 1.5             |      |
| Analog voltage                      | V <sub>DDA</sub> with respect to V <sub>SSA</sub>  | -0.3 | 4.6             | V    |
| Input voltage                       | V <sub>IN</sub> (3.3 V)  | -0.3 | 4.6             | V    |
| Output voltage                      | V <sub>O</sub>   | -0.3 | 4.6             | V    |
| Supply ramp rate                    | V <sub>DDIO</sub> , V <sub>DD18</sub> , V <sub>DD12</sub> , V <sub>DDA</sub> with respect to V <sub>SS</sub> |      | 10 <sup>5</sup> | V/s  |
| Input clamp current                 | I <sub>IK</sub> (V <sub>IN</sub> < 0 or V <sub>IN</sub> > V <sub>DDIO</sub> ) <sup>(3)</sup>                 | -20  | 20              | mA   |
| Output clamp current                | I <sub>OK</sub> (V <sub>O</sub> < 0 or V <sub>O</sub> > V <sub>DDIO</sub> )                                  | -20  | 20              | mA   |
| Free-Air temperature                | T <sub>A</sub>   | -40  | 125             | °C   |
| Junction temperature <sup>(4)</sup> | T <sub>J</sub>   | -40  | 150             | °C   |
| Storage temperature <sup>(4)</sup>  | T <sub>stg</sub>   | -65  | 150             | °C   |

- (1) Stresses beyond those listed under *Absolute Maximum Ratings* may cause permanent damage to the device. These are stress ratings only, and functional operation of the device at these or any other conditions beyond those indicated under *Recommended Operating Conditions* is not implied. Exposure to absolute-maximum-rated conditions for extended periods may affect device reliability.
- (2) All voltage values are with respect to V<sub>SS</sub>, unless otherwise noted.
- (3) Continuous clamp current per pin is ±2 mA.
- (4) Long-term high-temperature storage or extended use at maximum temperature conditions may result in a reduction of overall device life. For additional information, see [Semiconductor and IC Package Thermal Metrics](#).

### 5.2 ESD Ratings – Automotive

|  |   |  | VALUE | UNIT |
|--|---|--|-------|------|
| <b>F28M35H52C in 144-pin RFP package</b>   |   |  |       |      |
| V <sub>(ESD)</sub> Electrostatic discharge | Human body model (HBM), per AEC Q100-002 <sup>(1)</sup> | All pins   | ±2000 | V    |
|  |   | Charged device model (CDM), per AEC Q100-011                 | ±500  |      |
|  |   | Corner pins on 144-pin RFP: 1, 36, 37, 72, 73, 108, 109, 144 | ±750  |      |

- (1) AEC Q100-002 indicates HBM stressing is done in accordance with the ANSI/ESDA/JEDEC JS-001 specification.

### 5.3 ESD Ratings – Commercial

|  |  |  | VALUE | UNIT |
|--|--|--|-------|------|
| <b>F28M35H22C, F28M35M52C, F28M35M22C, F28M35M20B, F28M35E20B in 144-pin RFP package</b> |  |  |       |      |
| V <sub>(ESD)</sub> Electrostatic discharge   | Human-body model (HBM), per ANSI/ESDA/JEDEC JS-001 <sup>(1)</sup>              |  | ±2000 | V    |
|  | Charged-device model (CDM), per JEDEC specification JESD22-C101 <sup>(2)</sup> |  | ±500  |      |

- (1) JEDEC document JEP155 states that 500-V HBM allows safe manufacturing with a standard ESD control process.
- (2) JEDEC document JEP157 states that 250-V CDM allows safe manufacturing with a standard ESD control process.

## 5.4 Recommended Operating Conditions

|   |  | MIN  | NOM | MAX   | UNIT |
|---|--|------|-----|-------|------|
| Device supply voltage, I/O, $V_{DDIO}^{(1)}$  |  | 2.97 | 3.3 | 3.63  | V    |
| Device supply voltage, Analog Subsystem, $V_{DD18}$<br>(when internal VREG is disabled and 1.8 V is supplied externally)              |  | 1.71 | 1.8 | 1.995 | V    |
| Device supply voltage, Master and Control Subsystems, $V_{DD12}$<br>(when internal VREG is disabled and 1.2 V is supplied externally) |  | 1.14 | 1.2 | 1.32  | V    |
| Supply ground, $V_{SS}$   |  |      | 0   |       | V    |
| Analog supply voltage, $V_{DDA}^{(1)}$  |  | 2.97 | 3.3 | 3.63  | V    |
| Analog ground, $V_{SSA}$  |  |      | 0   |       | V    |
| Device clock frequency (system clock)<br><i>Master Subsystem</i>  | H52C, H22C   | 2    |     | 100   | MHz  |
|   | M52C, M22C, M20B                                     | 2    |     | 75    |      |
|   | E20B   | 2    |     | 60    |      |
| Device clock frequency (system clock)<br><i>Control Subsystem</i>   | H52C, H22C   | 2    |     | 150   | MHz  |
|   | M52C, M22C, M20B                                     | 2    |     | 75    |      |
|   | E20B   | 2    |     | 60    |      |
| Junction temperature, $T_J$   | T version  | –40  |     | 105   | °C   |
|   | S version <sup>(2)</sup>                             | –40  |     | 125   |      |
|   | Q version<br>(AEC Q100 qualification) <sup>(2)</sup> | –40  |     | 150   |      |
| Free-Air temperature, $T_A$   | Q version<br>(AEC Q100 qualification)                | –40  |     | 125   | °C   |

(1)  $V_{DDIO}$  and  $V_{DDA}$  should be maintained within approximately 0.3 V of each other.

(2) Operation above  $T_J = 105^\circ\text{C}$  for extended duration will reduce the lifetime of the device. See [Calculating Useful Lifetimes of Embedded Processors](#) for more information.

## 5.5 Power Consumption Summary

**Table 5-1. Current Consumption at 150-MHz C28x SYSCLKOUT and 75-MHz M3SSCLK**

| MODE              | TEST CONDITIONS <sup>(1)</sup>  | VREG ENABLED                     |        |                  |       | VREG DISABLED     |       |                   |        |                                  |       |                  |       |
|-------------------|---|----------------------------------|--------|------------------|-------|-------------------|-------|-------------------|--------|----------------------------------|-------|------------------|-------|
|                   |   | I <sub>DDIO</sub> <sup>(2)</sup> |        | I <sub>DDA</sub> |       | I <sub>DD18</sub> |       | I <sub>DD12</sub> |        | I <sub>DDIO</sub> <sup>(2)</sup> |       | I <sub>DDA</sub> |       |
|                   |   | TYP                              | MAX    | TYP              | MAX   | TYP               | MAX   | TYP               | MAX    | TYP                              | MAX   | TYP              | MAX   |
| Operational (RAM) | <p>The following Cortex-M3 peripherals are exercised:</p> <ul style="list-style-type: none"> <li>I2C1</li> <li>SSI1, SSI2</li> <li>UART0, UART1, UART2</li> <li>CAN0</li> <li>USB</li> <li>μDMA</li> <li>Timer0, Timer1</li> <li>μCRC</li> <li>WDOG0, WDOG1</li> <li>Flash</li> <li>Internal Oscillator 1, Internal Oscillator 2</li> </ul> <p>The following C28x peripherals are exercised:</p> <ul style="list-style-type: none"> <li>McBSP</li> <li>eQEP1, eQEP2</li> <li>eCAP1, eCAP2, eCAP3, eCAP4</li> <li>SCI-A</li> <li>SPI-A</li> <li>I2C</li> <li>DMA</li> <li>VCU</li> <li>FPU</li> <li>Flash</li> </ul> <p>The following Analog peripherals are exercised:</p> <ul style="list-style-type: none"> <li>ADC1, ADC2</li> <li>Comparator 1, Comparator 2, Comparator 3, Comparator 4, Comparator 5, Comparator 6</li> </ul> | -                                | 325 mA | -                | 40 mA | -                 | 25 mA | -                 | 225 mA | -                                | 65 mA | -                | 40 mA |

- (1) The following is done in a loop:
- Code is running out of RAM.
  - All I/O pins are left unconnected.
  - All the communication peripherals are exercised in loop-back mode.
  - USB – Only logic is exercised by loading and unloading FIFO.
  - μDMA does memory-to-memory transfer.
  - DMA does memory-to-memory transfer.
  - VCU – CRC calculated and checked.
  - FPU – Float operations performed.
  - ePWM – 6 enabled and generates 150-kHz PWM output on 12 pins, HRPWM clock enabled.
  - Timers and Watchdog serviced.
  - eCAP in APWM mode generates 36.6-kHz output on 4 pins.
  - ADC performs continuous conversion.
  - FLASH is continuously read and in active state.
  - XCLKOUT is turned off.
- (2) I<sub>DDIO</sub> current is dependent on the electrical loading on the I/O pins.

**Table 5-1. Current Consumption at 150-MHz C28x SYSCLKOUT and 75-MHz M3SSCLK (continued)**

| MODE               | TEST CONDITIONS <sup>(1)</sup>   | VREG ENABLED                     |        |                  |      | VREG DISABLED     |       |                   |        |                                  |       |                  |      |
|--------------------|--|----------------------------------|--------|------------------|------|-------------------|-------|-------------------|--------|----------------------------------|-------|------------------|------|
|                    |  | I <sub>DDIO</sub> <sup>(2)</sup> |        | I <sub>DDA</sub> |      | I <sub>DD18</sub> |       | I <sub>DD12</sub> |        | I <sub>DDIO</sub> <sup>(2)</sup> |       | I <sub>DDA</sub> |      |
|                    |  | TYP                              | MAX    | TYP              | MAX  | TYP               | MAX   | TYP               | MAX    | TYP                              | MAX   | TYP              | MAX  |
| SLEEP IDLE         | <ul style="list-style-type: none"> <li>• PLL is on.</li> <li>• Cortex-M3 CPU is not executing.</li> <li>• M3SSCLK is on.</li> <li>• C28CLKIN is on.</li> <li>• C28x CPU is not executing.</li> <li>• C28CPUCLK is off.</li> <li>• C28SYSCLK is on.</li> </ul>        | –                                | 146 mA | –                | 2 mA | –                 | 20 mA | –                 | 110 mA | –                                | 11 mA | –                | 2 mA |
| SLEEP STANDBY      | <ul style="list-style-type: none"> <li>• PLL is on.</li> <li>• Cortex-M3 CPU is not executing.</li> <li>• M3SSCLK is on.</li> <li>• C28CLKIN is off.</li> <li>• C28x CPU is not executing.</li> <li>• C28CPUCLK is off.</li> <li>• C28SYSCLK is off.</li> </ul>      | –                                | 126 mA | –                | 2 mA | –                 | 20 mA | –                 | 90 mA  | –                                | 11 mA | –                | 2 mA |
| DEEP SLEEP STANDBY | <ul style="list-style-type: none"> <li>• PLL is off.</li> <li>• Cortex-M3 CPU is not executing.</li> <li>• M3SSCLK is 32 kHz.</li> <li>• C28CLKIN is off.</li> <li>• C28x CPU is not executing.</li> <li>• C28CPUCLK is off.</li> <li>• C28SYSCLK is off.</li> </ul> | –                                | 76 mA  | –                | 2 mA | –                 | 5 mA  | –                 | 60 mA  | –                                | 7 mA  | –                | 2 mA |

**Table 5-2. Current Consumption at 100-MHz C28x SYSCLKOUT and 100-MHz M3SSCLK**

| MODE              | TEST CONDITIONS <sup>(1)</sup>   | VREG ENABLED                     |        |                  |       | VREG DISABLED     |       |                   |        |                                  |       |                  |       |
|-------------------|--|----------------------------------|--------|------------------|-------|-------------------|-------|-------------------|--------|----------------------------------|-------|------------------|-------|
|                   |  | I <sub>DDIO</sub> <sup>(2)</sup> |        | I <sub>DDA</sub> |       | I <sub>DD18</sub> |       | I <sub>DD12</sub> |        | I <sub>DDIO</sub> <sup>(2)</sup> |       | I <sub>DDA</sub> |       |
|                   |  | TYP                              | MAX    | TYP              | MAX   | TYP               | MAX   | TYP               | MAX    | TYP                              | MAX   | TYP              | MAX   |
| Operational (RAM) | The following Cortex-M3 peripherals are exercised: <ul style="list-style-type: none"> <li>• I2C1</li> <li>• SSI1, SSI2</li> <li>• UART0, UART1, UART2</li> <li>• CAN0</li> <li>• USB</li> <li>• <math>\mu</math>DMA</li> <li>• Timer0, Timer1</li> <li>• <math>\mu</math>CRC</li> <li>• WDOG0, WDOG1</li> <li>• Flash</li> <li>• Internal Oscillator 1, Internal Oscillator 2</li> </ul> The following C28x peripherals are exercised: <ul style="list-style-type: none"> <li>• McBSP</li> <li>• eQEP1, eQEP2</li> <li>• eCAP1, eCAP2, eCAP3, eCAP4</li> <li>• SCI-A</li> <li>• SPI-A</li> <li>• I2C</li> <li>• DMA</li> <li>• VCU</li> <li>• FPU</li> <li>• Flash</li> </ul> The following Analog peripherals are exercised: <ul style="list-style-type: none"> <li>• ADC1, ADC2</li> <li>• Comparator 1, Comparator 2, Comparator 3, Comparator 4, Comparator 5, Comparator 6</li> </ul> | -                                | 295 mA | -                | 40 mA | -                 | 20 mA | -                 | 200 mA | -                                | 65 mA | -                | 40 mA |

- (1) The following is done in a loop:
- Code is running out of RAM.
  - All I/O pins are left unconnected.
  - All the communication peripherals are exercised in loop-back mode.
  - USB – Only logic is exercised by loading and unloading FIFO.
  - $\mu$ DMA does memory-to-memory transfer.
  - DMA does memory-to-memory transfer.
  - VCU – CRC calculated and checked.
  - FPU – Float operations performed.
  - ePWM – 6 enabled and generates 150-kHz PWM output on 12 pins, HRPWM clock enabled.
  - Timers and Watchdog serviced.
  - eCAP in APWM mode generates 36.6-kHz output on 4 pins.
  - ADC performs continuous conversion.
  - FLASH is continuously read and in active state.
  - XCLKOUT is turned off.
- (2) I<sub>DDIO</sub> current is dependent on the electrical loading on the I/O pins.

**Table 5-3. Current Consumption at 75-MHz C28x SYSCLKOUT and 75-MHz M3SSCLK**

| MODE              | TEST CONDITIONS <sup>(1)</sup>   | VREG ENABLED                     |        |                  |       | VREG DISABLED     |       |                   |        |                                  |       |                  |       |
|-------------------|--|----------------------------------|--------|------------------|-------|-------------------|-------|-------------------|--------|----------------------------------|-------|------------------|-------|
|                   |  | I <sub>DDIO</sub> <sup>(2)</sup> |        | I <sub>DDA</sub> |       | I <sub>DD18</sub> |       | I <sub>DD12</sub> |        | I <sub>DDIO</sub> <sup>(2)</sup> |       | I <sub>DDA</sub> |       |
|                   |  | TYP                              | MAX    | TYP              | MAX   | TYP               | MAX   | TYP               | MAX    | TYP                              | MAX   | TYP              | MAX   |
| Operational (RAM) | The following Cortex-M3 peripherals are exercised: <ul style="list-style-type: none"> <li>• I2C1</li> <li>• SSI1, SSI2</li> <li>• UART0, UART1, UART2</li> <li>• CAN0</li> <li>• USB</li> <li>• <math>\mu</math>DMA</li> <li>• Timer0, Timer1</li> <li>• <math>\mu</math>CRC</li> <li>• WDOG0, WDOG1</li> <li>• Flash</li> <li>• Internal Oscillator 1, Internal Oscillator 2</li> </ul> The following C28x peripherals are exercised: <ul style="list-style-type: none"> <li>• McBSP</li> <li>• eQEP1, eQEP2</li> <li>• eCAP1, eCAP2, eCAP3, eCAP4</li> <li>• SCI-A</li> <li>• SPI-A</li> <li>• I2C</li> <li>• DMA</li> <li>• VCU</li> <li>• FPU</li> <li>• Flash</li> </ul> The following Analog peripherals are exercised: <ul style="list-style-type: none"> <li>• ADC1, ADC2</li> <li>• Comparator 1, Comparator 2, Comparator 3, Comparator 4, Comparator 5, Comparator 6</li> </ul> | -                                | 275 mA | -                | 40 mA | -                 | 25 mA | -                 | 175 mA | -                                | 65 mA | -                | 40 mA |

- (1) The following is done in a loop:
- Code is running out of RAM.
  - All I/O pins are left unconnected.
  - All the communication peripherals are exercised in loop-back mode.
  - USB – Only logic is exercised by loading and unloading FIFO.
  - $\mu$ DMA does memory-to-memory transfer.
  - DMA does memory-to-memory transfer.
  - VCU – CRC calculated and checked.
  - FPU – Float operations performed.
  - ePWM – 6 enabled and generates 150-kHz PWM output on 12 pins, HRPWM clock enabled.
  - Timers and Watchdog serviced.
  - eCAP in APWM mode generates 36.6-kHz output on 4 pins.
  - ADC performs continuous conversion.
  - FLASH is continuously read and in active state.
  - XCLKOUT is turned off.
- (2) I<sub>DDIO</sub> current is dependent on the electrical loading on the I/O pins.

**Table 5-4. Current Consumption at 60-MHz C28x SYSCLKOUT and 60-MHz M3SSCLK**

| MODE              | TEST CONDITIONS <sup>(1)</sup>   | VREG ENABLED                     |        |                  |       | VREG DISABLED     |       |                   |        |                                  |       |                  |       |
|-------------------|--|----------------------------------|--------|------------------|-------|-------------------|-------|-------------------|--------|----------------------------------|-------|------------------|-------|
|                   |  | I <sub>DDIO</sub> <sup>(2)</sup> |        | I <sub>DDA</sub> |       | I <sub>DD18</sub> |       | I <sub>DD12</sub> |        | I <sub>DDIO</sub> <sup>(2)</sup> |       | I <sub>DDA</sub> |       |
|                   |  | TYP                              | MAX    | TYP              | MAX   | TYP               | MAX   | TYP               | MAX    | TYP                              | MAX   | TYP              | MAX   |
| Operational (RAM) | The following Cortex-M3 peripherals are exercised: <ul style="list-style-type: none"> <li>• I2C1</li> <li>• SSI1, SSI2</li> <li>• UART0, UART1, UART2</li> <li>• CAN0</li> <li>• USB</li> <li>• μDMA</li> <li>• Timer0, Timer1</li> <li>• μCRC</li> <li>• WDOG0, WDOG1</li> <li>• Flash</li> <li>• Internal Oscillator 1, Internal Oscillator 2</li> </ul> The following C28x peripherals are exercised: <ul style="list-style-type: none"> <li>• McBSP</li> <li>• eQEP1, eQEP2</li> <li>• eCAP1, eCAP2, eCAP3, eCAP4</li> <li>• SCI-A</li> <li>• SPI-A</li> <li>• I2C</li> <li>• DMA</li> <li>• VCU</li> <li>• FPU</li> <li>• Flash</li> </ul> The following Analog peripherals are exercised: <ul style="list-style-type: none"> <li>• ADC1, ADC2</li> <li>• Comparator 1, Comparator 2, Comparator 3, Comparator 4, Comparator 5, Comparator 6</li> </ul> | -                                | 250 mA | -                | 40 mA | -                 | 20 mA | -                 | 155 mA | -                                | 65 mA | -                | 40 mA |

- (1) The following is done in a loop:
- Code is running out of RAM.
  - All I/O pins are left unconnected.
  - All the communication peripherals are exercised in loop-back mode.
  - USB – Only logic is exercised by loading and unloading FIFO.
  - μDMA does memory-to-memory transfer.
  - DMA does memory-to-memory transfer.
  - VCU – CRC calculated and checked.
  - FPU – Float operations performed.
  - ePWM – 6 enabled and generates 150-kHz PWM output on 12 pins, HRPWM clock enabled.
  - Timers and Watchdog serviced.
  - eCAP in APWM mode generates 36.6-kHz output on 4 pins.
  - ADC performs continuous conversion.
  - FLASH is continuously read and in active state.
  - XCLKOUT is turned off.
- (2) I<sub>DDIO</sub> current is dependent on the electrical loading on the I/O pins.

**NOTE**

The peripheral-I/O multiplexing implemented in the device prevents all available peripherals from being used at the same time because more than one peripheral function may share an I/O pin. It is, however, possible to turn on the clocks to all the peripherals at the same time, although such a configuration is not useful. If the clocks to all the peripherals are turned on at the same time, the current drawn by the device will be more than the numbers specified in the current consumption tables (Table 5-1, Table 5-2, Table 5-3, and Table 5-4).

## 5.6 Electrical Characteristics

over recommended operating conditions (unless otherwise noted)

| PARAMETER       |  | TEST CONDITIONS  |  | MIN                         | TYP | MAX                     | UNIT |    |
|-----------------|--|--|--|-----------------------------|-----|-------------------------|------|----|
| V <sub>IL</sub> | Low-level input voltage (3.3 V)  |  |  | V <sub>SS</sub> – 0.3       |     | V <sub>DDIO</sub> * 0.3 | V    |    |
| V <sub>IH</sub> | High-level input voltage (3.3 V)   |  |  | V <sub>DDIO</sub> * 0.7     |     | V <sub>DDIO</sub> + 0.3 | V    |    |
| V <sub>OL</sub> | Low-level output voltage   | I <sub>OL</sub> = I <sub>OL</sub> MAX                              |  |                             |     | V <sub>DDIO</sub> * 0.2 | V    |    |
| V <sub>OH</sub> | High-level output voltage  | I <sub>OH</sub> = I <sub>OH</sub> MAX                              |  | V <sub>DDIO</sub> * 0.8     |     |                         | V    |    |
|                 |  | I <sub>OH</sub> = 50 μA  |  | V <sub>DDIO</sub> – 0.2     |     |                         |      |    |
| I <sub>IL</sub> | Input current (low level)  | Pin with pullup enabled  | V <sub>DDIO</sub> = 3.3 V, V <sub>IN</sub> = 0 V               | All GPIO pins               |     | –50                     | –230 | μA |
|                 |  |  |  | $\overline{\text{XRS}}$ pin |     | –50                     | –230 |    |
|                 |  |  |  | $\overline{\text{ARS}}$ pin |     | –100                    | –400 |    |
|                 |  | Pin with pulldown enabled  | V <sub>DDIO</sub> = 3.3 V, V <sub>IN</sub> = 0 V               |                             |     | ±2 <sup>(1)</sup>       |      |    |
| I <sub>IH</sub> | Input current (high level)   | Pin with pullup enabled  | V <sub>DDIO</sub> = 3.3 V, V <sub>IN</sub> = V <sub>DDIO</sub> |                             |     | ±2 <sup>(1)</sup>       | μA   |    |
|                 |  | Pin with pulldown enabled  | V <sub>DDIO</sub> = 3.3 V, V <sub>IN</sub> = V <sub>DDIO</sub> | 50                          |     | 200                     |      |    |
| I <sub>OL</sub> | Low-level output sink current, V <sub>OL</sub> = V <sub>OL(MAX)</sub>    | All GPIO/AIO pins  |  |                             |     | 4                       | mA   |    |
|                 |  | Group 2 <sup>(2)</sup>   |  |                             |     | 8                       |      |    |
| I <sub>OH</sub> | High-level output source current, V <sub>OH</sub> = V <sub>OH(MIN)</sub> | All GPIO/AIO pins  |  |                             |     | –4                      | mA   |    |
|                 |  | Group 2 <sup>(2)</sup>   |  |                             |     | –8                      |      |    |
| I <sub>OZ</sub> | Output current, pullup or pulldown disabled                              | V <sub>O</sub> = V <sub>DDIO</sub> or 0 V                          |  |                             |     | ±2 <sup>(1)</sup>       | μA   |    |
| C <sub>I</sub>  | Input capacitance  |  |  |                             | 2   |                         | pF   |    |
|                 | Digital Subsystem POR reset release delay time                           | Time after POR event is removed to $\overline{\text{XRS}}$ release |  |                             | 50  |                         | μs   |    |
|                 | Analog Subsystem POR reset release delay time                            | Time after POR event is removed to $\overline{\text{ARS}}$ release |  | 400                         |     | 800                     | μs   |    |
|                 | VREG V <sub>DD18</sub> output  | Internal VREG18 on   |  | 1.77                        |     | 1.935                   | V    |    |
|                 | VREG V <sub>DD12</sub> output  | Internal VREG12 on   |  |                             | 1.2 |                         | V    |    |

(1) For GPIO38 and GPIO46 (USB OTG pins), this parameter is ±8 μA.

(2) Group 2 pins are as follows: PD3\_GPIO19, PE2\_GPIO26, PE3\_GPIO27, PH6\_GPIO54, PH7\_GPIO55, EMU0, TDO, EMU1, PD0\_GPIO16, AIO7, AIO4.

## 5.7 Thermal Resistance Characteristics for RFP PowerPAD Package

|                                  |   | °C/W <sup>(1)</sup> | AIR FLOW (lfm) <sup>(2)</sup> |
|----------------------------------|---|---------------------|-------------------------------|
| R <sub>θJC</sub>                 | Junction-to-case thermal resistance     | 6.3                 | 0                             |
| R <sub>θJB</sub>                 | Junction-to-board thermal resistance    | 4.4                 | 0                             |
| R <sub>θJA</sub><br>(High k PCB) | Junction-to-free air thermal resistance | 18.8                | 0                             |
|                                  |   | 11.5                | 150                           |
|                                  |   | 10.0                | 250                           |
|                                  |   | 8.6                 | 500                           |
| Psi <sub>JT</sub>                | Junction-to-package top                 | 0.3                 | 0                             |
|                                  |   | 0.2                 | 150                           |
|                                  |   | 0.3                 | 250                           |
|                                  |   | 0.3                 | 500                           |
| Psi <sub>JB</sub>                | Junction-to-board                       | 4.8                 | 0                             |
|                                  |   | 4.6                 | 150                           |
|                                  |   | 4.5                 | 250                           |
|                                  |   | 4.4                 | 500                           |

(1) These values are based on a JEDEC defined 2S2P system (with the exception of the Theta JC [R<sub>θJC</sub>] value, which is based on a JEDEC defined 1S0P system) and will change based on environment as well as application. For more information, see these EIA/JEDEC standards:

- JESD51-2, *Integrated Circuits Thermal Test Method Environmental Conditions - Natural Convection (Still Air)*
- JESD51-3, *Low Effective Thermal Conductivity Test Board for Leaded Surface Mount Packages*
- JESD51-7, *High Effective Thermal Conductivity Test Board for Leaded Surface Mount Packages*
- JESD51-9, *Test Boards for Area Array Surface Mount Package Thermal Measurements*

(2) lfm = linear feet per minute

## 5.8 Thermal Design Considerations

Based on the end-application design and operational profile, the I<sub>DD12</sub>, I<sub>DD18</sub>, and I<sub>DDIO</sub> currents could vary. Systems that exceed the recommended maximum power dissipation in the end product may require additional thermal enhancements. Ambient temperature (T<sub>A</sub>) varies with the end application and product design. The critical factor that affects reliability and functionality is T<sub>J</sub>, the junction temperature, not the ambient temperature. Hence, care should be taken to keep T<sub>J</sub> within the specified limits. T<sub>case</sub> should be measured to estimate the operating junction temperature T<sub>J</sub>. T<sub>case</sub> is normally measured at the center of the package top-side surface. For more details about thermal metrics and definitions, see [Semiconductor and IC Package Thermal Metrics](#).

## 5.9 Timing and Switching Characteristics

### 5.9.1 Power Sequencing

There is no power sequencing requirement needed to ensure the device is in the proper state after reset or to prevent the I/Os from glitching during power up and power down. (All I/Os, except for GPIO135, are glitch-free during power up and power down.) No voltage larger than a diode drop (0.7 V) above  $V_{DDIO}$  should be applied to any digital pin (for analog pins, this value is 0.7 V above  $V_{DDA}$ ) before powering up the device. Voltages applied to pins on an unpowered device can bias internal p-n junctions in unintended ways and produce unpredictable results.

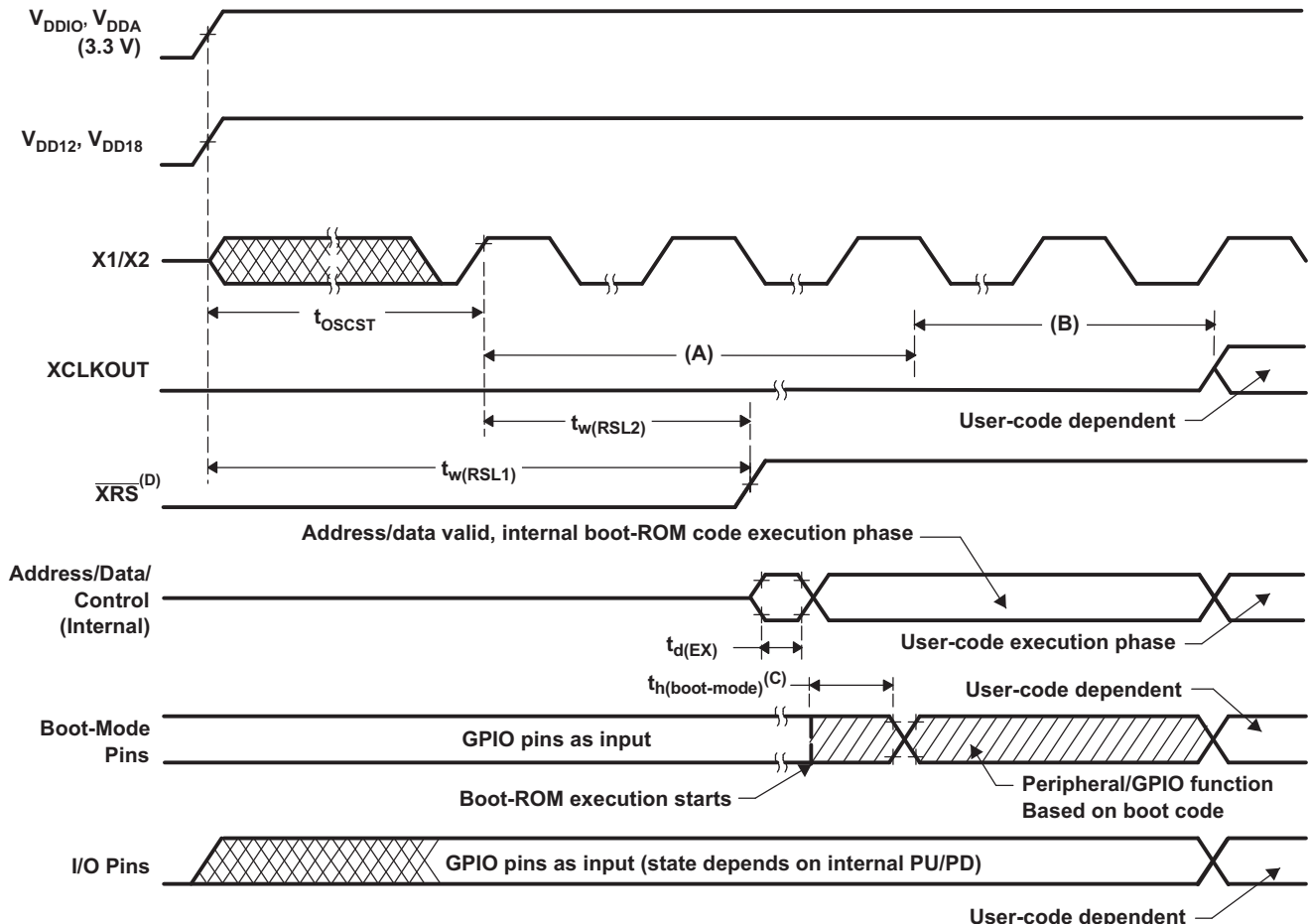

- Upon power up, PLLSYSCLK is OSCCLK/8. Because the XCLKOUTDIV bits in the XCLK register come up with a reset state of 0, PLLSYSCLK is further divided by 4 before PLLSYSCLK appears at XCLKOUT. XCLKOUT = OSCCLK/32 during this phase.
- Boot ROM configures the SYSDIVSEL bits for /1 operation. XCLKOUT = OSCCLK/4 during this phase. XCLKOUT will not be visible at the pin until explicitly configured by user code.
- After reset, the boot ROM code samples Boot Mode pins. Based on the status of the Boot Mode pin, the boot code branches to destination memory or boot code function. If boot ROM code executes after power-on conditions (in debugger environment), the boot code execution time is based on the current M3SSCLK speed. The M3SSCLK will be based on user environment and could be with or without PLL enabled.
- The  $\overline{XRS}$  pin will be driven low by on-chip POR circuitry until the  $V_{DDIO}$  voltage crosses the POR threshold. (The POR threshold is lower than the operating voltage requirement.) To allow the external clock to stabilize, the  $\overline{XRS}$  pin may also need to be driven low by the system for additional time.

Figure 5-1. Power-On Reset

**Table 5-5. Reset ( $\overline{\text{XRS}}$ ) Timing Requirements**

|                                 |   | MIN   | MAX                 | UNIT   |
|---------------------------------|---|-------|---------------------|--------|
| $t_{h(\text{boot-mode})}^{(1)}$ | Hold time for boot-mode pins                | 14000 | $t_{c(\text{M3C})}$ | cycles |
| $t_{w(\text{RSL2})}$            | Pulse duration, $\overline{\text{XRS}}$ low | 32    | $t_{c(\text{OCK})}$ | cycles |

(1) The minimum hold time for boot mode pins is 23 times longer for silicon revision 0 devices.

**Table 5-6. Reset ( $\overline{\text{XRS}}$ ) Switching Characteristics**

over recommended operating conditions (unless otherwise noted)

| PARAMETER                |   | MIN | TYP | MAX                 | UNIT          |
|--------------------------|---|-----|-----|---------------------|---------------|
| $t_{w(\text{RSL1})}$     | Pulse duration, $\overline{\text{XRS}}$ driven by device          |     | 600 |                     | $\mu\text{s}$ |
| $t_{w(\text{WDRS})}$     | Pulse duration, reset pulse generated by watchdog                 |     | 512 | $t_{c(\text{OCK})}$ | cycles        |
| $t_{d(\text{EX})}$       | Delay time, address/data valid after $\overline{\text{XRS}}$ high |     | 32  | $t_{c(\text{OCK})}$ | cycles        |
| $t_{\text{INTOSCST}}$    | Start-up time, internal zero-pin oscillator                       |     | 3   |                     | $\mu\text{s}$ |
| $t_{\text{OSCST}}^{(1)}$ | On-chip crystal-oscillator start-up time                          |     | 2   |                     | ms            |

(1) Dependent on crystal/resonator and board design.

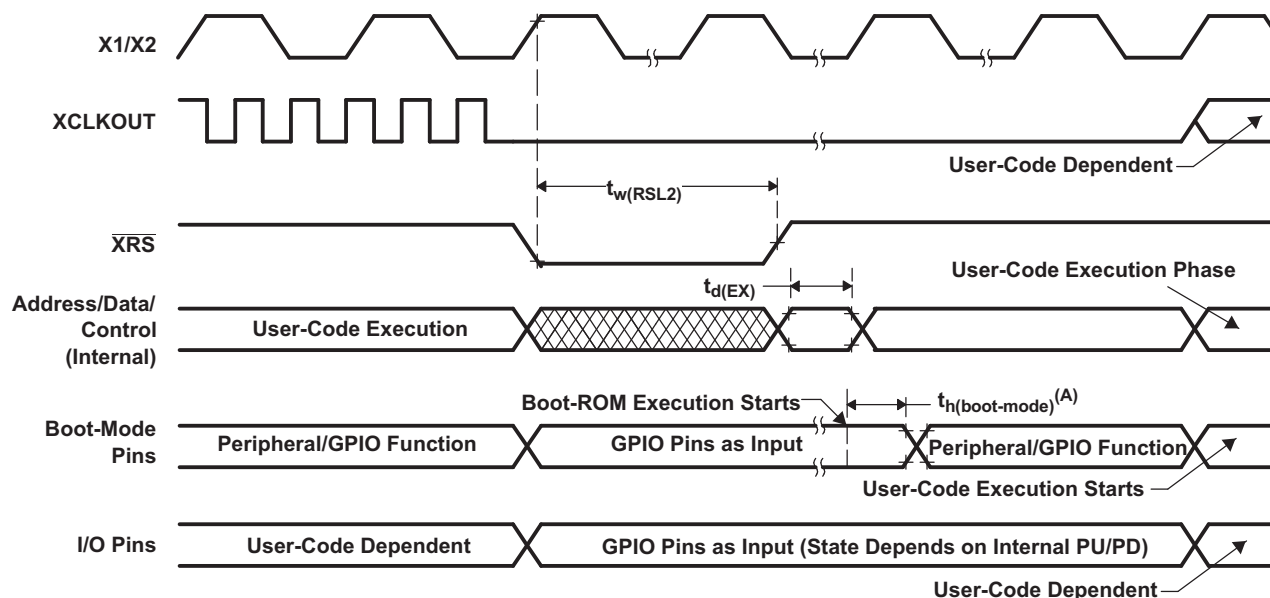

A. After reset, the Boot ROM code samples BOOT Mode pins. Based on the status of the Boot Mode pin, the boot code branches to destination memory or boot code function. If Boot ROM code executes after power-on conditions (in debugger environment), the Boot code execution time is based on the current M3SSCLK speed. The M3SSCLK will be based on user environment and could be with or without PLL enabled.

**Figure 5-2. Warm Reset**

**5.9.1.1 Power Management and Supervisory Circuit Solutions**

LDO selection depends on the total power consumed in the end application. Go to [www.ti.com](http://www.ti.com) and click on *Power Management* for a complete list of TI power ICs or select the *Power Management Selection Guide* link for specific power reference designs.

## 5.9.2 Clock Specifications

This section provides the frequencies and timing requirements of the input clocks; PLL lock times; frequencies of the internal clocks; and the frequency and switching characteristics of the output clock.

### 5.9.2.1 Changing the Frequency of the Main PLL

When configuring the PLL, it should be locked *twice* in a row. The PLL will be ready to use in the system when the xPLLSTS[xPLLLOCKS] bit is set after the second lock. The SysCtlClockPllConfig () function in sysctl.c, found in controlSUITE™, may be referenced as an example of a proper PLL initialization sequence. For additional information, see the "Clock Control" section of the [Concerto F28M35x Technical Reference Manual](#).

### 5.9.2.2 Input Clock Frequency and Timing Requirements, PLL Lock Times

Table 5-7 shows the frequency requirements for the input clocks to the F28M35x devices. Table 5-8 shows the crystal equivalent series resistance requirements. Table 5-10, Table 5-11, Table 5-12, and Table 5-13 show the timing requirements for the input clocks to the F28M35x devices. Table 5-14 shows the PLL lock times for the Main PLL and the USB PLL. The Main PLL operates from the X1 or X1/X2 input clock pins, and the USB PLL operates from the XCLKIN input clock pin.

**Table 5-7. Input Clock Frequency**

|                    |   | MIN | MAX | UNIT |
|--------------------|---|-----|-----|------|
| f <sub>(OSC)</sub> | Frequency, X1/X2, from external crystal or resonator            | 2   | 20  | MHz  |
| f <sub>(OCI)</sub> | Frequency, X1, from external oscillator ( <b>PLL enabled</b> )  | 2   | 30  | MHz  |
| f <sub>(OCI)</sub> | Frequency, X1, from external oscillator ( <b>PLL disabled</b> ) | 2   | 100 | MHz  |
| f <sub>(XCI)</sub> | Frequency, XCLKIN, from external oscillator                     | 2   | 60  | MHz  |

**Table 5-8. Crystal Equivalent Series Resistance (ESR) Requirements<sup>(1)</sup>**

| CRYSTAL FREQUENCY (MHz) | MAXIMUM ESR (Ω)<br>(CL1/2 = 12 pF) | MAXIMUM ESR (Ω)<br>(CL1/2 = 24 pF) |
|-------------------------|------------------------------------|------------------------------------|
| 2                       | 175                                | 375                                |
| 4                       | 100                                | 195                                |
| 6                       | 75                                 | 145                                |
| 8                       | 65                                 | 120                                |
| 10                      | 55                                 | 110                                |
| 12                      | 50                                 | 95                                 |
| 14                      | 50                                 | 90                                 |
| 16                      | 45                                 | 75                                 |
| 18                      | 45                                 | 65                                 |
| 20                      | 45                                 | 50                                 |

(1) Crystal shunt capacitance (C0) should be less than or equal to 7 pF.

**Table 5-9. Crystal Oscillator Electrical Characteristics**

over recommended operating conditions (unless otherwise noted)

| PARAMETER                    | TEST CONDITIONS   | MIN | TYP | MAX | UNIT |
|------------------------------|---|-----|-----|-----|------|
| Start-up time <sup>(1)</sup> | f = 20 MHz; ESR MAX = 50 Ω;<br>CL1 = CL2 = 24 pF, C0 = 7 pF |     | 2   |     | ms   |

(1) Start-up time is dependent on the crystal and tank circuit components. It is recommended that the crystal vendor characterize the application with the chosen crystal.

**Table 5-10. X1 Timing Requirements - PLL Enabled<sup>(1)</sup>**

|              |   | MIN | MAX | UNIT |
|--------------|---|-----|-----|------|
| $t_{f(OCI)}$ | Fall time, X1   |     | 6   | ns   |
| $t_{r(OCI)}$ | Rise time, X1   |     | 6   | ns   |
| $t_{w(OCL)}$ | Pulse duration, X1 low as a percentage of $t_{c(OCI)}$  | 45% | 55% |      |
| $t_{w(OCH)}$ | Pulse duration, X1 high as a percentage of $t_{c(OCI)}$ | 45% | 55% |      |

(1) The possible Main PLL configuration modes are shown in [Table 6-19](#) to [Table 6-22](#).

**Table 5-11. X1 Timing Requirements - PLL Disabled**

|              |   |                   | MIN | MAX | UNIT |
|--------------|---|-------------------|-----|-----|------|
| $t_{f(OCI)}$ | Fall time, X1   | Up to 20 MHz      |     | 6   | ns   |
|              |   | 20 MHz to 100 MHz |     | 2   |      |
| $t_{r(OCI)}$ | Rise time, X1   | Up to 20 MHz      |     | 6   | ns   |
|              |   | 20 MHz to 100 MHz |     | 2   |      |
| $t_{w(OCL)}$ | Pulse duration, X1 low as a percentage of $t_{c(OCI)}$  |                   | 45% | 55% |      |
| $t_{w(OCH)}$ | Pulse duration, X1 high as a percentage of $t_{c(OCI)}$ |                   | 45% | 55% |      |

**Table 5-12. XCLKIN Timing Requirements - PLL Enabled<sup>(1)</sup>**

|              |   | MIN | MAX | UNIT |
|--------------|---|-----|-----|------|
| $t_{f(XCI)}$ | Fall time, XCLKIN   |     | 6   | ns   |
| $t_{r(XCI)}$ | Rise time, XCLKIN   |     | 6   | ns   |
| $t_{w(XCL)}$ | Pulse duration, XCLKIN low as a percentage of $t_{c(XCI)}$  | 45% | 55% |      |
| $t_{w(XCH)}$ | Pulse duration, XCLKIN high as a percentage of $t_{c(XCI)}$ | 45% | 55% |      |

(1) The possible USB PLL configuration modes are shown in [Table 6-23](#) and [Table 6-24](#).

**Table 5-13. XCLKIN Timing Requirements - PLL Disabled**

|              |   |                   | MIN | MAX | UNIT |
|--------------|---|-------------------|-----|-----|------|
| $t_{f(XCI)}$ | Fall time, XCLKIN   | Up to 20 MHz      |     | 6   | ns   |
|              |   | 20 MHz to 100 MHz |     | 2   |      |
| $t_{r(XCI)}$ | Rise time, XCLKIN   | Up to 20 MHz      |     | 6   | ns   |
|              |   | 20 MHz to 100 MHz |     | 2   |      |
| $t_{w(XCL)}$ | Pulse duration, XCLKIN low as a percentage of $t_{c(XCI)}$  |                   | 45% | 55% |      |
| $t_{w(XCH)}$ | Pulse duration, XCLKIN high as a percentage of $t_{c(XCI)}$ |                   | 45% | 55% |      |

**Table 5-14. PLL Lock Times**

|           |   | MIN | NOM                 | MAX | UNIT               |
|-----------|---|-----|---------------------|-----|--------------------|
| $t_{PLL}$ | Lock time, Main PLL (X1, from external oscillator)    |     | 2000 <sup>(1)</sup> |     | input clock cycles |
| $t_{USB}$ | Lock time, USB PLL (XCLKIN, from external oscillator) |     | 2000 <sup>(1)</sup> |     | input clock cycles |

(1) For example, if the input clock to the PLL is 10 MHz, then a single PLL lock time is 100 ns × 2000 = 200 μs. This defines the time of a single write to the PLL configuration registers until the xPLLSTS[xPLLLOCKS] bit is set. The PLL should be locked *twice* to ensure a good PLL output frequency is present.

### 5.9.2.3 Output Clock Frequency and Switching Characteristics

Table 5-15 provides the frequency of the output clock from the F28M35x devices. Table 5-16 shows the switching characteristics of the output clock from the F28M35x devices, XCLKOUT.

**Table 5-15. Output Clock Frequency**

|             |                    | MIN | MAX  | UNIT |
|-------------|--------------------|-----|------|------|
| $f_{(XCO)}$ | Frequency, XCLKOUT | 2   | 37.5 | MHz  |

**Table 5-16. XCLKOUT Switching Characteristics (PLL Bypassed or Enabled)<sup>(1)(2)</sup>**

over recommended operating conditions (unless otherwise noted)

| PARAMETER     | MIN                          | TYP   | MAX   | UNIT |
|---------------|------------------------------|-------|-------|------|
| $t_{f(XCO)}$  | Fall time, XCLKOUT           |       | 5     | ns   |
| $t_{r(XCO)}$  | Rise time, XCLKOUT           |       | 5     | ns   |
| $t_{w(XCOL)}$ | Pulse duration, XCLKOUT low  | H – 2 | H + 2 | ns   |
| $t_{w(XCOH)}$ | Pulse duration, XCLKOUT high | H – 2 | H + 2 | ns   |

(1) A load of 40 pF is assumed for these parameters.

(2)  $H = 0.5t_{c(XCO)}$

### 5.9.2.4 Internal Clock Frequencies

Table 5-17 provides the clock frequencies for the internal clocks of the F28M35x devices.

**Table 5-17. Internal Clock Frequencies (150-MHz Devices)**

|             | MIN                                 | NOM | MAX                 | UNIT |
|-------------|-------------------------------------|-----|---------------------|------|
| $f_{(USB)}$ | Frequency, USBPLLCLK                | 60  |                     | MHz  |
| $f_{(PLL)}$ | Frequency, PLLSYSCLK                | 2   | 150                 | MHz  |
| $f_{(OCK)}$ | Frequency, OSCCLK                   | 2   | 100                 | MHz  |
| $f_{(M3C)}$ | Frequency, M3SSCLK                  | 2   | 100 <sup>(1)</sup>  | MHz  |
| $f_{(ADC)}$ | Frequency, ASYSCLK                  | 2   | 37.5                | MHz  |
| $f_{(SYS)}$ | Frequency, C28SYSCLK                | 2   | 150 <sup>(1)</sup>  | MHz  |
| $f_{(HSP)}$ | Frequency, C28HSPCLK                | 2   | 150 <sup>(1)</sup>  | MHz  |
| $f_{(LSP)}$ | Frequency, C28LSPCLK <sup>(2)</sup> | 2   | 37.5 <sup>(3)</sup> | MHz  |
| $f_{(10M)}$ | Frequency, 10MHzCLK                 |     | 10                  | MHz  |
| $f_{(32K)}$ | Frequency, 32KHzCLK                 |     | 32                  | kHz  |

(1) An integer divide ratio must be maintained between the C28x and Cortex-M3 clock frequencies. For example, when the C28x is configured to run at a maximum frequency of 150 MHz, the fastest allowable frequency for the Cortex-M3 will be 75 MHz. See Figure 6-10 and Figure 6-12 to see the internal clocks and clock divider options.

(2) Lower LSPCLK will reduce device power consumption.

(3) This is the default reset value if C28SYSCLK = 150 MHz.

### 5.9.3 Timing Parameter Symbolology

Timing parameter symbols used are created in accordance with JEDEC Standard 100. To shorten the symbols, some of the pin names and other related terminology have been abbreviated as follows:

| Lowercase subscripts and their meanings: |                        | Letters and symbols and their meanings: |  |
|--|------------------------|---|--|
| a  | access time            | H                                       | High                                   |
| c  | cycle time (period)    | L                                       | Low                                    |
| d  | delay time             | V                                       | Valid                                  |
| f  | fall time              | X                                       | Unknown, changing, or don't care level |
| h  | hold time              | Z                                       | High impedance                         |
| r  | rise time              |   |  |
| su                                       | setup time             |   |  |
| t  | transition time        |   |  |
| v  | valid time             |   |  |
| w  | pulse duration (width) |   |  |

#### 5.9.3.1 General Notes on Timing Parameters

All output signals from the 28x devices (including XCLKOUT) are derived from an internal clock such that all output transitions for a given half-cycle occur with a minimum of skewing relative to each other.

The signal combinations shown in the following timing diagrams may not necessarily represent actual cycles. For actual cycle examples, see the appropriate cycle description section of this document.

#### 5.9.3.2 Test Load Circuit

This test load circuit is used to measure all switching characteristics provided in this document.

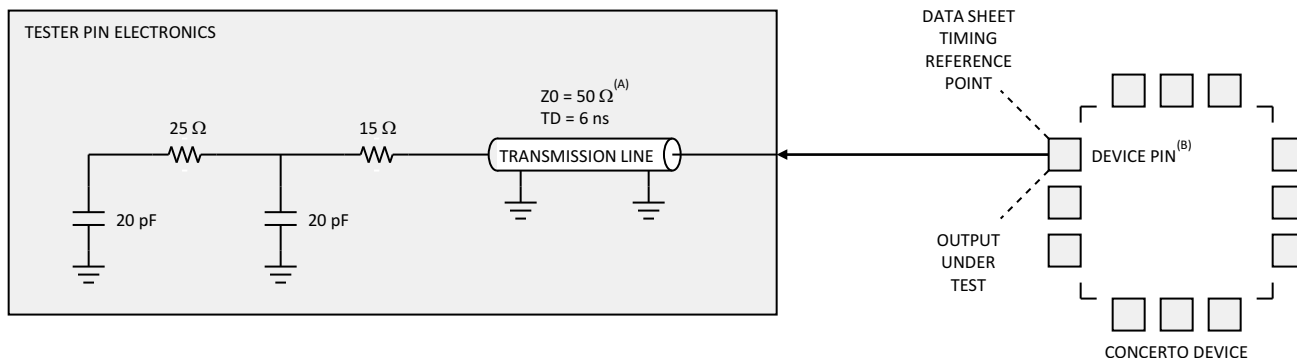

- A. Input requirements in this data sheet are tested with an input slew rate of < 4 Volts per nanosecond (4 V/ns) at the device pin.
- B. The data sheet provides timing at the device pin. For output timing analysis, the tester pin electronics and its transmission line effects must be taken into account. A transmission line with a delay of 2 ns or longer can be used to produce the desired transmission line effect. The transmission line is intended as a load only. It is not necessary to add or subtract the transmission line delay (2 ns or longer) from the data sheet timing.

Figure 5-3. 3.3-V Test Load Circuit

### 5.9.4 Flash Timing – Master Subsystem

**Table 5-18. Master Subsystem – Flash/OTP Endurance**

|           |  | MIN   | TYP   | MAX | UNIT   |
|-----------|--|-------|-------|-----|--------|
| $N_f$     | Flash endurance for the array (write/erase cycles) | 20000 | 50000 |     | cycles |
| $N_{OTP}$ | OTP endurance for the array (write cycles)         |       |       | 1   | write  |

**Table 5-19. Master Subsystem – Flash Parameters<sup>(1)</sup>**

| PARAMETER                                   |   | TEST CONDITIONS | MIN | TYP  | MAX | UNIT |
|---|---|-----------------|-----|------|-----|------|
| Program Time <sup>(2)</sup>                 | 128 data bits + 16 ECC bits                               |                 | 40  | 300  |     | µs   |
|   | 16K sector  |                 | 160 | 320  |     | ms   |
|   | 64K sector  |                 | 640 | 1280 |     | ms   |
| Erase Time <sup>(3)</sup><br>at < 25 cycles | 16K sector  |                 | 25  | 50   |     | ms   |
|   | 64K sector  |                 | 35  | 60   |     |      |
| Erase Time <sup>(3)</sup><br>at 50k cycles  | 16K sector  |                 | 115 | 4000 |     | ms   |
|   | 64K sector  |                 | 130 | 4000 |     |      |
| $I_{DDP}$ <sup>(4)(5)</sup>                 | $V_{DD}$ current consumption during Erase/Program cycle   | VREG disabled   | 105 |      |     | mA   |
| $I_{DDIOP}$ <sup>(4)(5)</sup>               | $V_{DDIO}$ current consumption during Erase/Program cycle |                 | 55  |      |     |      |
| $I_{DDIOP}$ <sup>(4)(5)</sup>               | $V_{DDIO}$ current consumption during Erase/Program cycle | VREG enabled    | 195 |      |     | mA   |

- (1) The on-chip flash memory is in an erased state when the device is shipped from TI. As such, erasing the flash memory is not required before programming, when programming the device for the first time. However, the erase operation is needed on all subsequent programming operations.
- (2) Program time includes overhead of the Flash state machine but does not include the time to transfer the following into RAM:
  - Code that uses Flash API to program the Flash
  - Flash API itself
  - Flash data to be programmed
 In other words, the time indicated in this table is applicable after all the required code/data is available in the device RAM, ready for programming. The transfer time will significantly vary depending on the speed of the emulator used. Program time calculation is based on programming 144 bits at a time at the specified operating frequency. Program time includes Program verify by the CPU. The program time does not degrade with write/erase (W/E) cycling, but the erase time does. Erase time includes Erase verify by the CPU and does not involve any data transfer.
- (3) Erase time includes Erase verify by the CPU.
- (4) Typical parameters as seen at room temperature including function call overhead, with all peripherals off. It is important to maintain a stable power supply during the entire flash programming process. It is conceivable that device current consumption during flash programming could be higher than normal operating conditions. The power supply used should ensure  $V_{MIN}$  on the supply rails at all times, as specified in the Recommended Operating Conditions of the data sheet. Any brown-out or interruption to power during erasing/programming could potentially corrupt the password locations and lock the device permanently. Powering a target board (during flash programming) through the USB port is not recommended, as the port may be unable to respond to the power demands placed during the programming process.
- (5) This current is measured with Flash API executing from RAM. There is not any data transfer through JTAG or any peripheral.

**Table 5-20. Master Subsystem – Flash/OTP Access Timing<sup>(1)</sup>**

| PARAMETER    |                   | MIN | MAX | UNIT |
|--------------|-------------------|-----|-----|------|
| $t_{a(f)}$   | Flash access time | 25  |     | ns   |
| $t_{a(OTP)}$ | OTP access time   | 50  |     | ns   |

- (1) Access time numbers shown in this table are before device characterization. Final numbers will be published in the data sheet for the fully qualified production device.

**Table 5-21. Master Subsystem – Flash Data Retention Duration**

| PARAMETER       |                         | TEST CONDITIONS          | MIN | MAX | UNIT  |
|-----------------|-------------------------|--------------------------|-----|-----|-------|
| $t_{retention}$ | Data retention duration | $T_J = 85^\circ\text{C}$ | 20  |     | years |

**Table 5-22. Master Subsystem – Minimum Required Flash/OTP Wait States at Different Frequencies**

| SYSCCLKOUT (MHz) | SYSCCLKOUT (ns) | WAIT STATE |
|------------------|-----------------|------------|
| 100              | 10              | 2          |
| 90               | 11.11           | 2          |
| 80               | 12.5            | 1          |
| 70               | 14.29           | 1          |
| 60               | 16.67           | 1          |
| 50               | 20              | 1          |
| 40               | 25              | 0          |
| 30               | 33.33           | 0          |
| 20               | 50              | 0          |
| 10               | 100             | 0          |

The equation to compute the Flash wait state in [Table 5-22](#) is as follows:

$$R_{WAIT} = \left[ \frac{\text{SYSCCLK (MHz)}}{40 \text{ (MHz)}} \right] - 1$$

round up to the next integer, or 1, whichever is larger.

### 5.9.5 Flash Timing – Control Subsystem

**Table 5-23. Control Subsystem – Flash/OTP Endurance**

|           |  | MIN   | TYP   | MAX | UNIT   |
|-----------|--|-------|-------|-----|--------|
| $N_f$     | Flash endurance for the array (write/erase cycles) | 20000 | 50000 |     | cycles |
| $N_{OTP}$ | OTP endurance for the array (write cycles)         |       |       | 1   | write  |

**Table 5-24. Control Subsystem – Flash Parameters<sup>(1)</sup>**

| PARAMETER                                   |   | TEST CONDITIONS | MIN | TYP  | MAX | UNIT |
|---|---|-----------------|-----|------|-----|------|
| Program Time <sup>(2)</sup>                 | 128 data bits + 16 ECC bits                               |                 | 40  | 300  |     | µs   |
|   | 16K sector  |                 | 120 | 240  |     | ms   |
|   | 64K sector  |                 | 480 | 960  |     | ms   |
| Erase Time <sup>(3)</sup><br>at < 25 cycles | 16K sector  |                 | 25  | 50   |     | ms   |
|   | 64K sector  |                 | 35  | 60   |     |      |
| Erase Time <sup>(3)</sup><br>at 50k cycles  | 16K sector  |                 | 105 | 4000 |     | ms   |
|   | 64K sector  |                 | 120 | 4000 |     |      |
| $I_{DDP}$ <sup>(4)(5)</sup>                 | $V_{DD}$ current consumption during Erase/Program cycle   | VREG disabled   | 90  |      |     | mA   |
| $I_{DDIOP}$ <sup>(4)(5)</sup>               | $V_{DDIO}$ current consumption during Erase/Program cycle |                 | 55  |      |     |      |
| $I_{DDIOP}$ <sup>(4)(5)</sup>               | $V_{DDIO}$ current consumption during Erase/Program cycle | VREG enabled    | 150 |      |     | mA   |

- (1) The on-chip flash memory is in an erased state when the device is shipped from TI. As such, erasing the flash memory is not required before programming, when programming the device for the first time. However, the erase operation is needed on all subsequent programming operations.
- (2) Program time includes overhead of the Flash state machine but does not include the time to transfer the following into RAM:
  - Code that uses Flash API to program the Flash
  - Flash API itself
  - Flash data to be programmed
 In other words, the time indicated in this table is applicable after all the required code/data is available in the device RAM, ready for programming. The transfer time will significantly vary depending on the speed of the emulator used. Program time calculation is based on programming 144 bits at a time at the specified operating frequency. Program time includes Program verify by the CPU. The program time does not degrade with write/erase (W/E) cycling, but the erase time does. Erase time includes Erase verify by the CPU and does not involve any data transfer.
- (3) Erase time includes Erase verify by the CPU.
- (4) Typical parameters as seen at room temperature including function call overhead, with all peripherals off. It is important to maintain a stable power supply during the entire flash programming process. It is conceivable that device current consumption during flash programming could be higher than normal operating conditions. The power supply used should ensure  $V_{MIN}$  on the supply rails at all times, as specified in the Recommended Operating Conditions of the data sheet. Any brown-out or interruption to power during erasing/programming could potentially corrupt the password locations and lock the device permanently. Powering a target board (during flash programming) through the USB port is not recommended, as the port may be unable to respond to the power demands placed during the programming process.
- (5) This current is measured with Flash API executing from RAM. There is not any data transfer through JTAG or any peripheral.

**Table 5-25. Control Subsystem – Flash/OTP Access Timing<sup>(1)</sup>**

| PARAMETER    |                   | MIN | MAX | UNIT |
|--------------|-------------------|-----|-----|------|
| $t_{a(f)}$   | Flash access time | 25  |     | ns   |
| $t_{a(OTP)}$ | OTP access time   | 50  |     | ns   |

- (1) Access time numbers shown in this table are before device characterization. Final numbers will be published in the data sheet for the fully qualified production device.

**Table 5-26. Control Subsystem – Flash Data Retention Duration**

| PARAMETER       | TEST CONDITIONS         | MIN                      | MAX | UNIT  |
|-----------------|-------------------------|--------------------------|-----|-------|
| $t_{retention}$ | Data retention duration | $T_J = 85^\circ\text{C}$ | 20  | years |

**Table 5-27. Control Subsystem – Minimum Required Flash/OTP Wait States at Different Frequencies**

| SYSCCLKOUT (MHz) | SYSCCLKOUT (ns) | WAIT STATE |
|------------------|-----------------|------------|
| 150              | 6.7             | 3          |
| 140              | 7.14            | 3          |
| 130              | 7.7             | 3          |
| 120              | 8.33            | 2          |
| 110              | 9.1             | 2          |
| 100              | 10              | 2          |
| 90               | 11.11           | 2          |
| 80               | 12.5            | 1          |
| 70               | 14.29           | 1          |
| 60               | 16.67           | 1          |
| 50               | 20              | 1          |
| 40               | 25              | 0          |
| 30               | 33.33           | 0          |
| 20               | 50              | 0          |
| 10               | 100             | 0          |

The equation to compute the Flash wait state in [Table 5-27](#) is as follows:

$$R_{WAIT} = \left[ \frac{\text{SYSCCLK (MHz)}}{40 \text{ (MHz)}} \right] - 1$$

round up to the next integer, or 1, whichever is larger.

## 5.9.6 GPIO Electrical Data and Timing

### 5.9.6.1 GPIO - Output Timing

**Table 5-28. General-Purpose Output Switching Characteristics**

over recommended operating conditions (unless otherwise noted)

| PARAMETER    |                                       |           | MIN | MAX | UNIT |
|--------------|---------------------------------------|-----------|-----|-----|------|
| $t_{r(GPO)}$ | Rise time, GPIO switching low to high | All GPIOs |     | 8   | ns   |
| $t_{f(GPO)}$ | Fall time, GPIO switching high to low | All GPIOs |     | 8   | ns   |
| $t_{GPO}$    | Toggling frequency, GPIO pins         |           |     | 25  | MHz  |

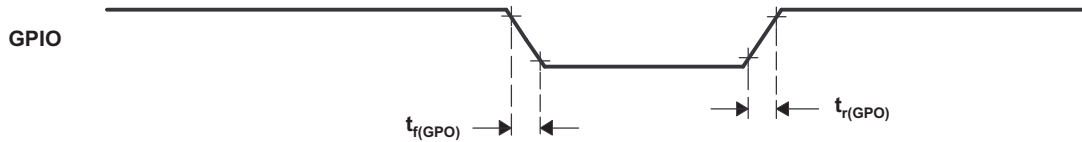

**Figure 5-4. General-Purpose Output Timing**

5.9.6.2 GPIO - Input Timing

Table 5-29. General-Purpose Input Timing Requirements

|                    |                                 |                      | MIN                                     | MAX | UNIT   |
|--------------------|---------------------------------|----------------------|---|-----|--------|
| $t_{w(SP)}$        | Sampling period                 | QUALPRD = 0          | $1t_{c(SCO)}$                           |     | cycles |
|                    |                                 | QUALPRD $\neq$ 0     | $2t_{c(SCO)} * QUALPRD$                 |     | cycles |
| $t_{w(IQSW)}$      | Input qualifier sampling window |                      | $t_{w(SP)} * (n^{(1)} - 1)$             |     | cycles |
| $t_{w(GPI)}^{(2)}$ | Pulse duration, GPIO low/high   | Synchronous mode     | $2t_{c(SCO)}$                           |     | cycles |
|                    |                                 | With input qualifier | $t_{w(IQSW)} + t_{w(SP)} + 1t_{c(SCO)}$ |     | cycles |

(1) "n" represents the number of qualification samples as defined by GPxQSELn register.

(2) For  $t_{w(GPI)}$ , pulse width is measured from  $V_{IL}$  to  $V_{IL}$  for an active low signal and  $V_{IH}$  to  $V_{IH}$  for an active high signal.

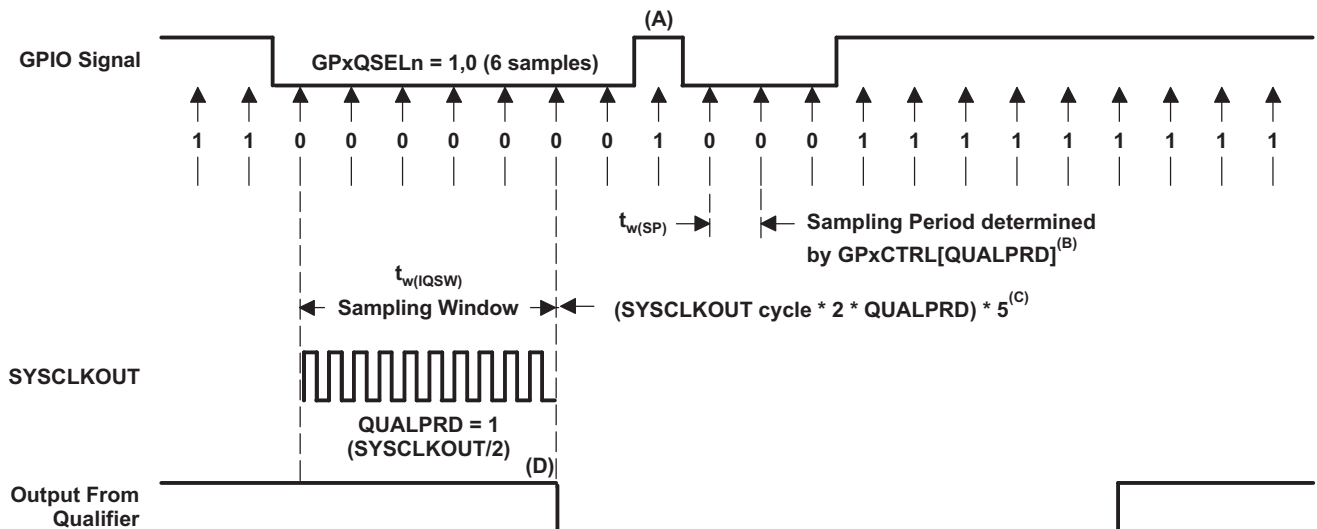

- A. This glitch will be ignored by the input qualifier. The QUALPRD bit field specifies the qualification sampling period. It can vary from 00 to 0xFF. If QUALPRD = 00, then the sampling period is 1 SYSCLKOUT cycle. For any other value "n", the qualification sampling period in 2n SYSCLKOUT cycles (that is, at every 2n SYSCLKOUT cycles, the GPIO pin will be sampled).
- B. The qualification period selected through the GPxCTRL register applies to groups of 8 GPIO pins.
- C. The qualification block can take either three or six samples. The GPxQSELn Register selects which sample mode is used.
- D. In the example shown, for the qualifier to detect the change, the input should be stable for 10 SYSCLKOUT cycles or greater. In other words, the inputs should be stable for  $(5 \times QUALPRD \times 2)$  SYSCLKOUT cycles. This would ensure 5 sampling periods for detection to occur. Because external signals are driven asynchronously, a 13-SYSCLKOUT-wide pulse ensures reliable recognition.

Figure 5-5. Sampling Mode

### 5.9.6.3 Sampling Window Width for Input Signals

The following section summarizes the sampling window width for input signals for various input qualifier configurations.

Sampling frequency denotes how often a signal is sampled with respect to SYSCLKOUT.

Sampling frequency =  $\text{SYSCLKOUT} / (2 * \text{QUALPRD})$ , if  $\text{QUALPRD} \neq 0$

Sampling frequency =  $\text{SYSCLKOUT}$ , if  $\text{QUALPRD} = 0$

Sampling period =  $\text{SYSCLKOUT cycle} \times 2 \times \text{QUALPRD}$ , if  $\text{QUALPRD} \neq 0$

In the above equations, SYSCLKOUT cycle indicates the time period of SYSCLKOUT.

Sampling period =  $\text{SYSCLKOUT cycle}$ , if  $\text{QUALPRD} = 0$

In a given sampling window, either 3 or 6 samples of the input signal are taken to determine the validity of the signal. This is determined by the value written to GPxQSELn register.

#### Case 1:

Qualification using 3 samples

Sampling window width =  $(\text{SYSCLKOUT cycle} \times 2 \times \text{QUALPRD}) \times 2$ , if  $\text{QUALPRD} \neq 0$

Sampling window width =  $(\text{SYSCLKOUT cycle}) \times 2$ , if  $\text{QUALPRD} = 0$

#### Case 2:

Qualification using 6 samples

Sampling window width =  $(\text{SYSCLKOUT cycle} \times 2 \times \text{QUALPRD}) \times 5$ , if  $\text{QUALPRD} \neq 0$

Sampling window width =  $(\text{SYSCLKOUT cycle}) \times 5$ , if  $\text{QUALPRD} = 0$

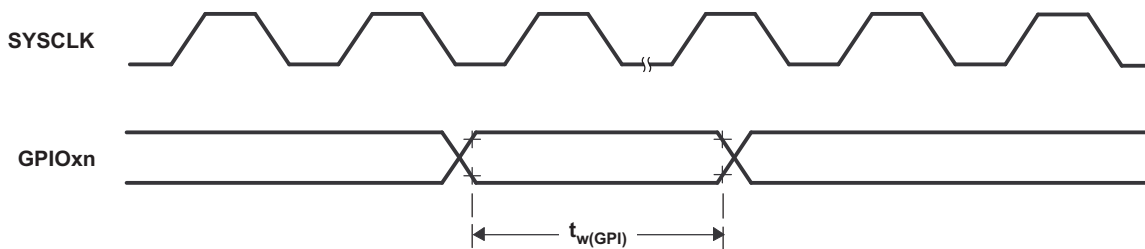

Figure 5-6. General-Purpose Input Timing

### 5.9.6.4 Low-Power Mode Wakeup Timing

Table 5-30 shows the timing requirements, Table 5-31 shows the switching characteristics, and Figure 5-7 shows the timing diagram for IDLE mode.

**Table 5-30. IDLE Mode Timing Requirements<sup>(1)</sup>**

|                   |   | MIN                     | MAX                         | UNIT   |
|-------------------|---|-------------------------|-----------------------------|--------|
| $t_{w(WAKE-INT)}$ | Pulse duration, external wake-up signal | Without input qualifier | $2t_{c(SCO)}$               | cycles |
|                   |   | With input qualifier    | $5t_{c(SCO)} + t_{w(IQSW)}$ |        |

(1) For an explanation of the input qualifier parameters, see Table 5-29.

**Table 5-31. IDLE Mode Switching Characteristics<sup>(1)</sup>**

over recommended operating conditions (unless otherwise noted)

| PARAMETER            |   | TEST CONDITIONS         | MIN                          | MAX                            | UNIT   |
|----------------------|---|-------------------------|------------------------------|--------------------------------|--------|
| $t_{d(WAKE-IDLE)}$   | Delay time, external wake signal to program execution resume <sup>(2)</sup> |                         |                              |                                |        |
|                      | Wake-up from Flash<br>• Flash module in active state                        | Without input qualifier |                              | $20t_{c(SCO)}$                 | cycles |
|                      |   | With input qualifier    |                              | $20t_{c(SCO)} + t_{w(IQSW)}$   |        |
|                      | Wake-up from Flash<br>• Flash module in sleep state                         | Without input qualifier |                              | $1050t_{c(SCO)}$               | cycles |
|                      |   | With input qualifier    |                              | $1050t_{c(SCO)} + t_{w(IQSW)}$ |        |
|                      | • Wake-up from SARAM  | Without input qualifier |                              | $20t_{c(SCO)}$                 | cycles |
| With input qualifier |   |                         | $20t_{c(SCO)} + t_{w(IQSW)}$ |                                |        |

(1) For an explanation of the input qualifier parameters, see Table 5-29.

(2) This is the time taken to begin execution of the instruction that immediately follows the IDLE instruction. execution of an ISR (triggered by the wake up) signal involves additional latency.

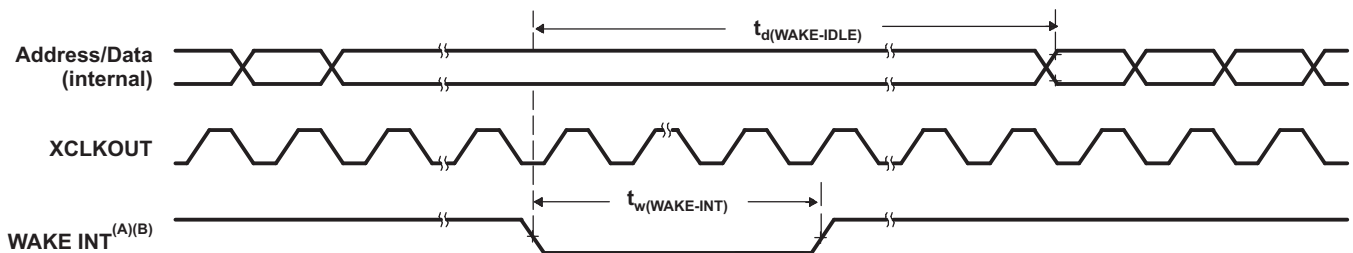

- A. WAKE INT can be any enabled interrupt,  $\overline{WDINT}$ ,  $XNMI$ , or  $\overline{XRS}$ .
- B. From the time the IDLE instruction is executed to place the device into low-power mode (LPM), wakeup should not be initiated until at least 4 OSCCLK cycles have elapsed.

**Figure 5-7. IDLE Entry and Exit Timing**

**Table 5-32. STANDBY Mode Timing Requirements**

|                   |   |   | MIN                               | MAX | UNIT   |
|-------------------|---|---|-----------------------------------|-----|--------|
| $t_{w(WAKE-INT)}$ | Pulse duration, external wake-up signal | Without input qualification             | $3t_{c(OSCCLK)}$                  |     | cycles |
|                   |   | With input qualification <sup>(1)</sup> | $(2 + QUALSTDBY) * t_{c(OSCCLK)}$ |     |        |

(1) QUALSTDBY is a 6-bit field in the LPMCR0 register.

**Table 5-33. STANDBY Mode Switching Characteristics**

over recommended operating conditions (unless otherwise noted)

| PARAMETER            |   | TEST CONDITIONS  | MIN                                | MAX             | UNIT   |
|----------------------|---|--|------------------------------------|-----------------|--------|
| $t_{d(IDLE-XCOL)}$   | Delay time, IDLE instruction executed to XCLKOUT low                        |  | $32t_{c(SCO)}$                     | $45t_{c(SCO)}$  | cycles |
| $t_{d(WAKE-STBY)}$   | Delay time, external wake signal to program execution resume <sup>(1)</sup> |  |                                    |                 |        |
|                      |   | • Wake up from flash<br>– Flash module in active state | Without input qualifier            | $100t_{c(SCO)}$ | cycles |
|                      |   | With input qualifier                                   | $100t_{c(SCO)} + t_{w(WAKE-INT)}$  |                 |        |
|                      | • Wake up from flash<br>– Flash module in sleep state                       | Without input qualifier                                | $1125t_{c(SCO)}$                   | cycles          |        |
|                      |   | With input qualifier                                   | $1125t_{c(SCO)} + t_{w(WAKE-INT)}$ |                 |        |
|                      | • Wake up from SARAM  | Without input qualifier                                | $100t_{c(SCO)}$                    | cycles          |        |
| With input qualifier |   | $100t_{c(SCO)} + t_{w(WAKE-INT)}$                      |                                    |                 |        |

(1) This is the time taken to begin execution of the instruction that immediately follows the IDLE instruction. execution of an ISR (triggered by the wake up signal) involves additional latency.

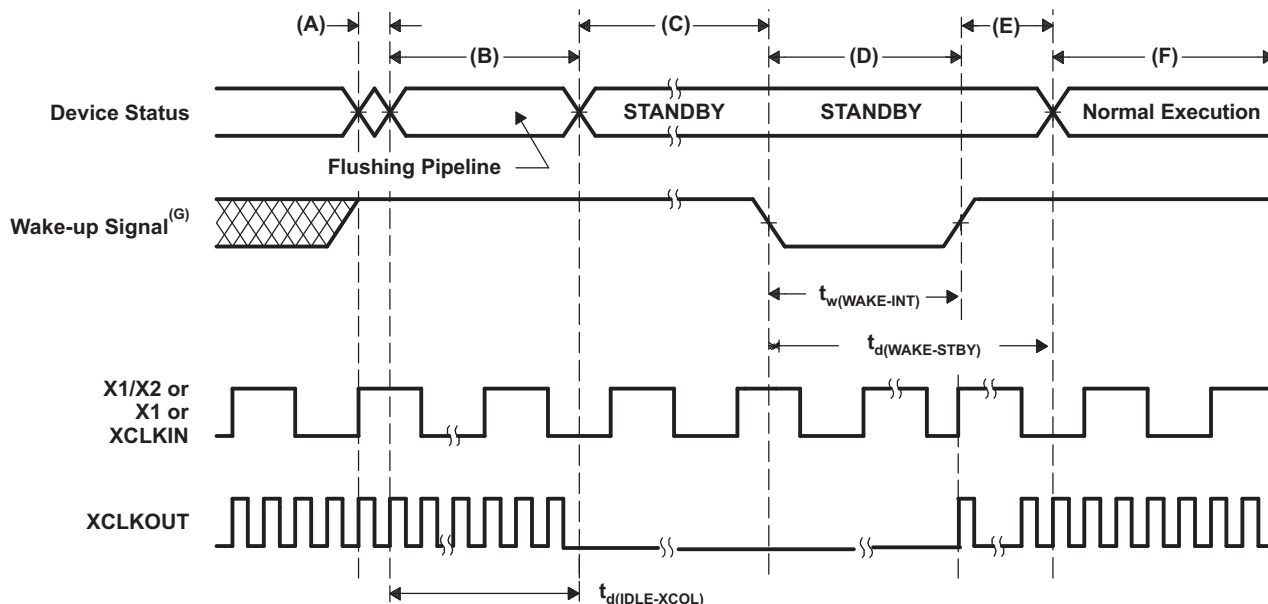

- A. IDLE instruction is executed to put the device into STANDBY mode.
- B. The PLL block responds to the STANDBY signal. SYSCLKOUT is held for the number of cycles indicated below before being turned off:
  - 16 cycles, when DIVSEL = 00 or 01
  - 32 cycles, when DIVSEL = 10
  - 64 cycles, when DIVSEL = 11

This delay enables the CPU pipeline and any other pending operations to flush properly. If an access to XINTF is in progress and its access time is longer than this number then it will fail. It is recommended to enter STANDBY mode from SARAM without an XINTF access in progress.
- C. Clock to the peripherals are turned off. However, the PLL and watchdog are not shut down. The device is now in STANDBY mode.
- D. The external wake-up signal is driven active.
- E. After a latency period, the STANDBY mode is exited.
- F. Normal execution resumes. The device will respond to the interrupt (if enabled).
- G. From the time the IDLE instruction is executed to place the device into low-power mode, wakeup should not be initiated until at least 4 OSCCLK cycles have elapsed.

**Figure 5-8. STANDBY Entry and Exit Timing Diagram**

**Table 5-34. HALT Mode Timing Requirements**

|                           |   | MIN  | MAX | UNIT   |
|---------------------------|---|--|-----|--------|
| $t_{w(\text{WAKE-GPIO})}$ | Pulse duration, GPIO wake-up signal                   | $t_{\text{oscst}} + 2t_{c(\text{OSCCLK})}^{(1)}$ |     | cycles |
| $t_{w(\text{WAKE-XRS})}$  | Pulse duration, $\overline{\text{XRS}}$ wakeup signal | $t_{\text{oscst}} + 8t_{c(\text{OSCCLK})}$       |     | cycles |

(1) See [Table 5-6](#) for an explanation of  $t_{\text{oscst}}$ .

**Table 5-35. HALT Mode Switching Characteristics**

over recommended operating conditions (unless otherwise noted)

| PARAMETER                 |   | MIN                          | MAX                   | UNIT   |
|---------------------------|---|------------------------------|-----------------------|--------|
| $t_{d(\text{IDLE-XCOL})}$ | Delay time, IDLE instruction executed to XCLKOUT low  | $32t_{c(\text{SCO})}$        | $45t_{c(\text{SCO})}$ | cycles |
| $t_p$                     | PLL lock-up time  | $131072t_{c(\text{OSCCLK})}$ |                       | cycles |
| $t_{d(\text{WAKE-HALT})}$ | Delay time, PLL lock to program execution resume  |                              |                       |        |
|                           | <ul style="list-style-type: none"> <li>• Wake up from flash                             <ul style="list-style-type: none"> <li>– Flash module in sleep state</li> </ul> </li> </ul> | $1125t_{c(\text{SCO})}$      |                       | cycles |
|                           | <ul style="list-style-type: none"> <li>• Wake up from SARAM</li> </ul>  | $35t_{c(\text{SCO})}$        |                       | cycles |

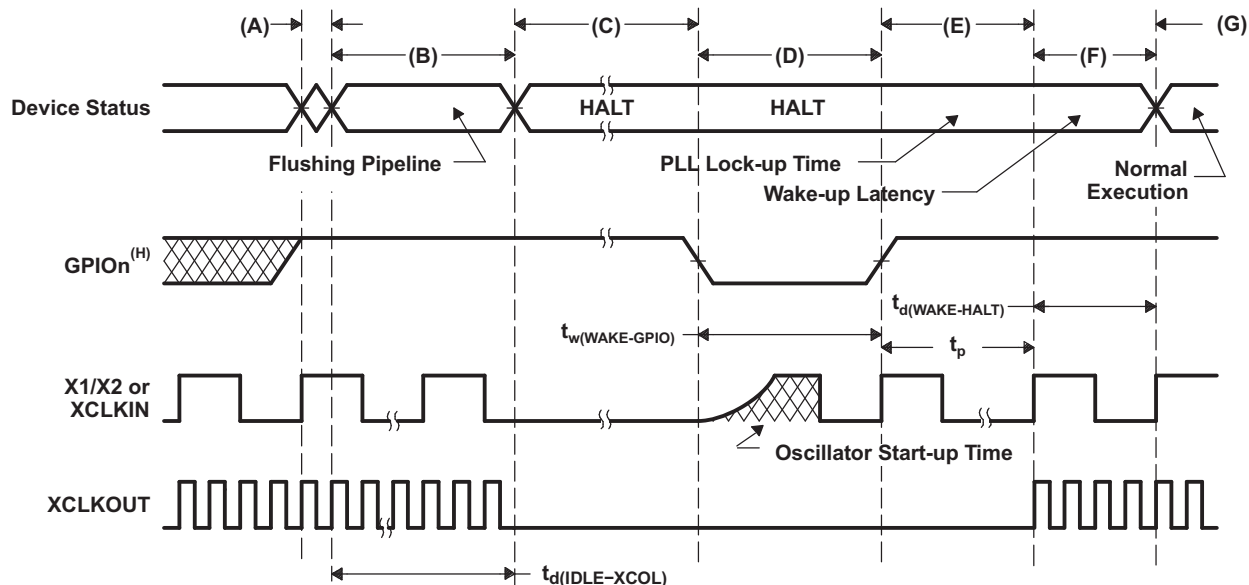

- A. IDLE instruction is executed to put the device into HALT mode.
- B. The PLL block responds to the HALT signal. SYSCLKOUT is held for the number of cycles indicated below before oscillator is turned off and the CLKIN to the core is stopped:
  - 16 cycles, when DIVSEL = 00 or 01
  - 32 cycles, when DIVSEL = 10
  - 64 cycles, when DIVSEL = 11
 This delay enables the CPU pipeline and any other pending operations to flush properly. If an access to XINTF is in progress and its access time is longer than this number then it will fail. It is recommended to enter HALT mode from SARAM without an XINTF access in progress.
- C. Clocks to the peripherals are turned off and the PLL is shut down. If a quartz crystal or ceramic resonator is used as the clock source, the internal oscillator is shut down as well. The device is now in HALT mode and consumes absolute minimum power.
- D. When the GPIO<sub>n</sub> pin (used to bring the device out of HALT) is driven low, the oscillator is turned on and the oscillator wake-up sequence is initiated. The GPIO pin should be driven high only after the oscillator has stabilized. This enables the provision of a clean clock signal during the PLL lock sequence. Because the falling edge of the GPIO pin asynchronously begins the wakeup process, care should be taken to maintain a low noise environment before entering and during HALT mode.
- E. Once the oscillator has stabilized, the PLL lock sequence is initiated, which takes 131,072 OSCCLK (X1/X2 or X1 or XCLKIN) cycles. These 131,072 clock cycles are applicable even when the PLL is disabled (that is, code execution will be delayed by this duration even when the PLL is disabled).
- F. Clocks to the core and peripherals are enabled. The HALT mode is now exited. The device will respond to the interrupt (if enabled), after a latency.
- G. Normal operation resumes.
- H. From the time the IDLE instruction is executed to place the device into low-power mode, wakeup should not be initiated until at least 4 OSCCLK cycles have elapsed.

Figure 5-9. HALT Wake-Up Using GPIO<sub>n</sub>

### 5.9.7 External Interrupt Electrical Data and Timing

**Table 5-36. External Interrupt Timing Requirements<sup>(1)</sup>**

|                             |                                    |                | MIN                         | MAX | UNIT   |
|-----------------------------|------------------------------------|----------------|-----------------------------|-----|--------|
| $t_{w(INT)}$ <sup>(2)</sup> | Pulse duration, INT input low/high | Synchronous    | $1t_{c(SCO)}$               |     | cycles |
|                             |                                    | With qualifier | $1t_{c(SCO)} + t_{w(IQSW)}$ |     | cycles |

(1) For an explanation of the input qualifier parameters, see [Table 5-29](#).

(2) This timing is applicable to any GPIO pin configured for ADCSOC functionality.

**Table 5-37. External Interrupt Switching Characteristics<sup>(1)</sup>**

over recommended operating conditions (unless otherwise noted)

| PARAMETER   | MIN                          | MAX | UNIT   |
|---|------------------------------|-----|--------|
| $t_{d(INT)}$ Delay time, INT low/high to interrupt-vector fetch | $t_{w(IQSW)} + 12t_{c(SCO)}$ |     | cycles |

(1) For an explanation of the input qualifier parameters, see [Table 5-29](#).

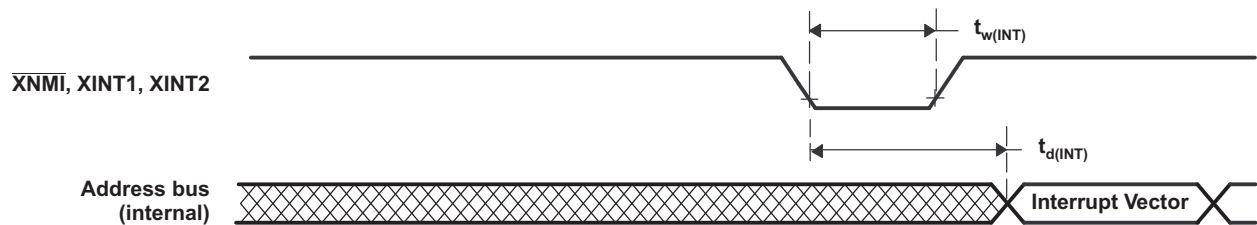

**Figure 5-10. External Interrupt Timing**

## 5.10 Analog and Shared Peripherals

Concerto Shared Peripherals are accessible from both the Master Subsystem and the Control Subsystem. The Analog Shared Peripherals include two 12-bit ADCs (Analog-to-Digital Converters), and six Comparator + DAC (10-bit) modules. The ADC Result Registers are accessible by CPUs and DMAs of the Master and Control Subsystems. All other analog registers, such as the ADC Configuration and Comparator Registers, are accessible by the C28x CPU only. The Digital Shared Peripherals include the IPC peripheral and the EPI. IPC is accessible by both CPUs; EPI is accessible by both CPUs and both DMAs.

IPC is used for sending and receiving synchronization events between Master and Control subsystems to coordinate execution of software running on both processors, or exchanging of data between the two processors. EPI is used by this device to communicate with external memory and other devices.

For detailed information on the processor peripherals, see the [Concerto F28M35x Technical Reference Manual](#).

### 5.10.1 Analog-to-Digital Converter

[Figure 5-11](#) shows the internal structure of each of the two ADC peripherals that are present on Concerto. Each ADC has 16 channels that can be programmed to select analog inputs, select start-of-conversion trigger, set the sampling window, and select end-of-conversion interrupt to prompt a CPU or DMA to read 16 result registers. The 16 ADC channels can be used independently or in pairs, based on the assignments inside the SAMPLEMODE register. Pairing up the channels allows two analog inputs to be sampled simultaneously—thereby, increasing the overall conversion performance.

#### 5.10.1.1 Sample Mode

Each ADC has 16 programmable channels that can be independently programmed for analog-to-digital conversion when corresponding bits in the SAMPLEMODE register are set to Sequential Mode. For example, if bit 2 in the SAMPLEMODE register is set to 0, ADC channels 4 and 5 are set to sequential mode. Both the SOC4CTL and SOC5CTL registers can then be programmed to configure channels 4 and 5 to independently perform analog-to-digital conversions with results being stored in the RESULT4 and RESULT5 registers. "Independently" means that channel 4 may use a different SOC trigger, different analog input, and different sampling window than the trigger, input, and window assigned to channel 5.

The 16 programmable channels for each ADC may also be grouped in 8 channel pairs when corresponding bits in the SAMPLEMODE register are set to Simultaneous Mode. For example, if bit 2 in the SAMPLEMODE register is set to 1, ADC channels 4 and 5 are set to Simultaneous Mode. The SOC4CTL register now contains configuration parameters for both channel 4 and channel 5, and the SOC5CTL register is ignored. While channel 4 and channel 5 are still using dedicated analog inputs (now selected as pairs in the CHSEL field of SOC4CTL), they both share the same SOC trigger and Sampling Window, with the results being stored in the RESULT4 and RESULT5 registers.

The Simultaneous mode is made possible by two sample-and-hold units present in each ADC. Each sample-and-hold unit has its own mux for selecting analog inputs (see [Figure 5-11](#)). By programming the SAMPLEMODE register, the 16 available channels can be configured as 16 independent channels, 8 channel pairs, or any combination thereof (for example, 10 sequential channels and 3 simultaneous pairs).

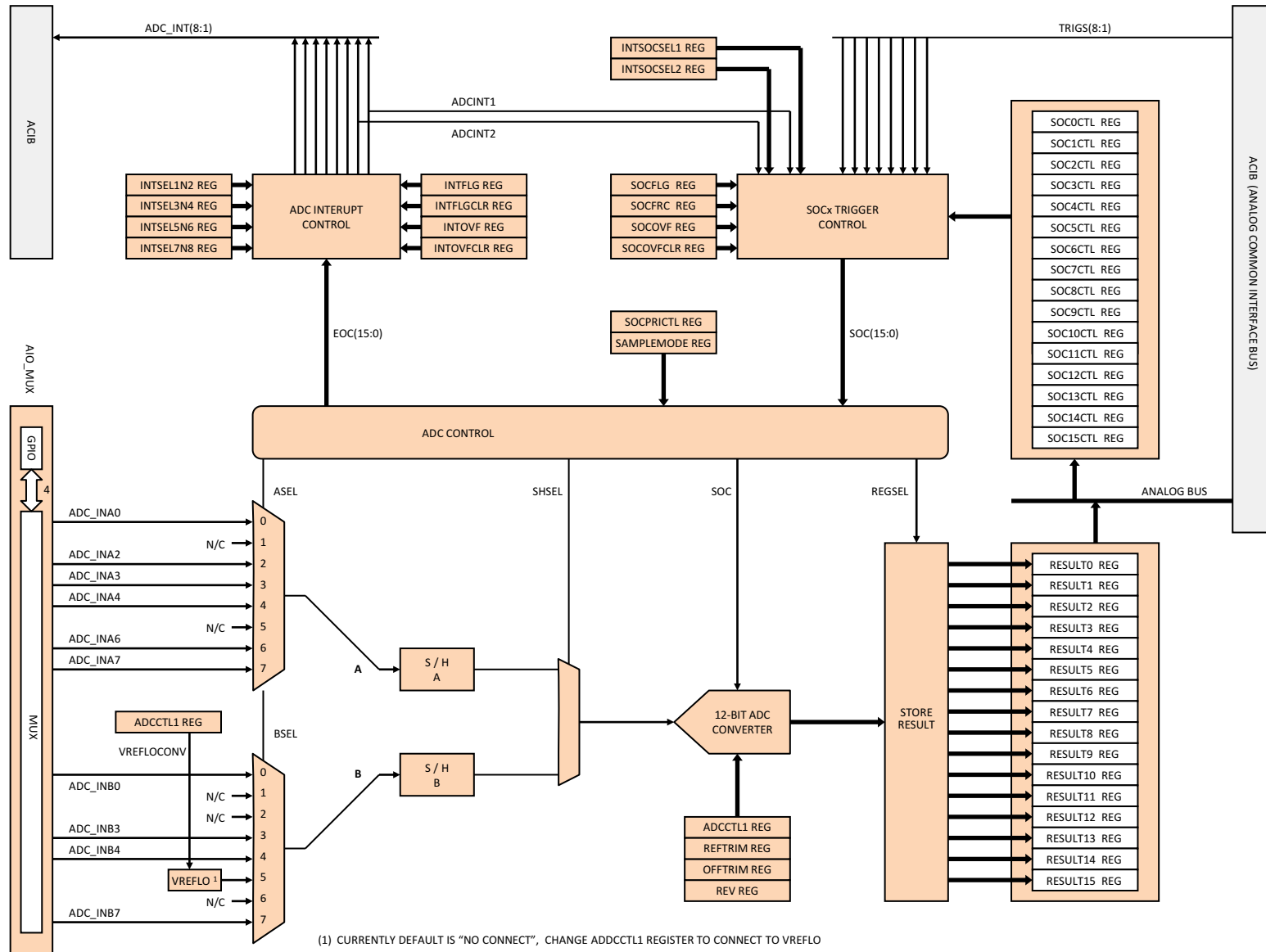

Figure 5-11. ADC

### 5.10.1.2 Start-of-Conversion Triggers

There are eight external SOC triggers that go to each of the two ADC modules (from the Control Subsystem). In addition to the eight external SOC triggers, there are also two internal SOC triggers derived from EOC interrupts inside each ADC module (ADCINT1 and ADCINT2). Registers INTSOCSEL1 and 2 are used to configure each of the 16 ADC channels for internal or external SOC sources. If internal SOC is chosen for a given channel, the INTSOCSEL1 and 2 registers also select whether the internal source is ADCINT1 or ADCINT2. If external SOC is chosen for a given ADC channel, the TRIGSEL field of the corresponding SOCxCTL register selects which of the eight external triggers is used for SOC in that channel. One analog-to-digital conversion can be performed at a time by the 12-bit ADC. The analog-to-digital conversion priority is managed according to the state of the PRICTL register.

### 5.10.1.3 Analog Inputs

Analog inputs to each of the two ADC modules are organized in two groups—A and B, with each group having a dedicated mux and sample-and-hold unit (see [Figure 5-11](#)). Mux A selects one of six possible analog inputs through AIO MUX. Mux B selects one of five possible analog inputs—four external inputs through AIO MUX, and one from the internal VREFLO signal, which is currently tied to the Analog Ground. The Mux A and Mux B inputs can be simultaneously or sequentially sampled by the two sample-and-hold units according to the sampling window chosen in the SOCxCTL register for the corresponding channel.

### 5.10.1.4 ADC Result Registers and EOC Interrupts

Concerto analog-to-digital conversion results are stored in 32 Results Registers (16 for ADC1 and 16 for ADC2). The 16 ADCx channels can be programmed through the INTSELxNy registers to trigger up to eight ADCINT interrupts per ADC module, when their results are ready to be read. The eight ADCINT interrupts from ADC1 and the eight ADCINT interrupts from ADC2 are AND-ed together before propagating to both the Master Subsystem and the Control Subsystem, announcing that the Result Registers are ready to be read by a CPU or DMA (see [Figure 6-3](#)).

**5.10.1.5 ADC Electrical Data and Timing**
**Table 5-38. ADC Electrical Characteristics**

over recommended operating conditions (unless otherwise noted)

| PARAMETER                                    |                                       | MIN                | TYP  | MAX                | UNIT       |
|--|---------------------------------------|--------------------|------|--------------------|------------|
| <b>DC SPECIFICATIONS</b>                     |                                       |                    |      |                    |            |
| Resolution                                   |                                       |                    | 12   |                    | Bits       |
| ADC clock                                    |                                       | 2                  |      | 37.5               | MHz        |
| Sample Window                                |                                       | 7                  |      | 64                 | ADC clocks |
| <b>ACCURACY</b>                              |                                       |                    |      |                    |            |
| INL (Integral nonlinearity)                  |                                       | -4                 |      | 4                  | LSB        |
| DNL (Differential nonlinearity)              |                                       | -1                 |      | 1.5                | LSB        |
| Offset error                                 | Executing a single self-recalibration | -20                | 0    | 20                 | LSB        |
|  | Executing periodic self-recalibration | -4                 | 0    | 4                  |            |
| Overall gain error with internal reference   |                                       | -60                |      | 60                 | LSB        |
| Overall gain error with external reference   |                                       | -40                |      | 40                 | LSB        |
| Channel-to-channel offset variation          |                                       | -4                 |      | 4                  | LSB        |
| Channel-to-channel gain variation            |                                       | -4                 |      | 4                  | LSB        |
| V <sub>REFLO</sub> input current             |                                       |                    | -100 |                    | μA         |
| V <sub>REFHI</sub> input current             |                                       |                    | 100  |                    | μA         |
| <b>ANALOG INPUT</b>                          |                                       |                    |      |                    |            |
| Analog input voltage with internal reference |                                       | 0                  |      | 3.3                | V          |
| Analog input voltage with external reference |                                       | V <sub>REFLO</sub> |      | V <sub>REFHI</sub> | V          |
| V <sub>REFLO</sub> input voltage             |                                       | V <sub>SSA</sub>   |      | 0.66               | V          |
| V <sub>REFHI</sub> input voltage             |                                       | 2.64               |      | V <sub>DDA</sub>   | V          |
| Input capacitance                            |                                       |                    | 5    |                    | pF         |
| Input leakage current                        |                                       |                    | ±2   |                    | μA         |
| <b>ADDITIONAL</b>                            |                                       |                    |      |                    |            |
| ADC SNR                                      |                                       |                    | 65   |                    | dB         |
| ADC SINAD                                    |                                       |                    | 62   |                    | dB         |
| ADC THD (50 kHz)                             |                                       |                    | -65  |                    | dB         |
| ENOB (SNR)                                   |                                       |                    | 10.1 |                    | Bits       |
| SFDR   |                                       |                    | 66   |                    | dB         |

Typical ADC Total Error

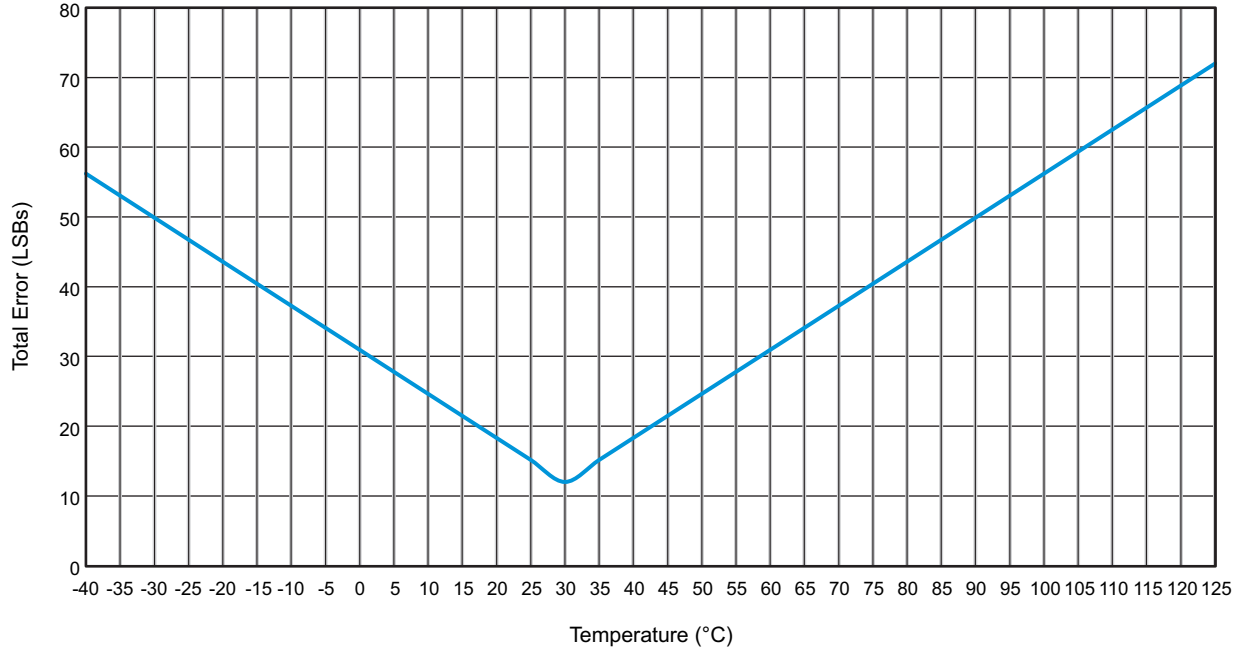

- A. Gain error contribution is based on sampling of full-scale voltage using internal reference mode.
- B. Periodic ADC offset recalibration is assumed.
- C. Total error shown represents the absolute value of possible error.

Figure 5-12. Typical ADC Total Error [Temperature (°C) versus Total Error (LSBs)]

Table 5-39. External ADC Start-of-Conversion Switching Characteristics

over recommended operating conditions (unless otherwise noted)

| PARAMETER  | MIN            | MAX | UNIT   |
|--|----------------|-----|--------|
| $t_{w(ADCSOCL)}$ Pulse duration, $\overline{ADCSOCxO}$ low | $32t_{c(HCO)}$ |     | cycles |

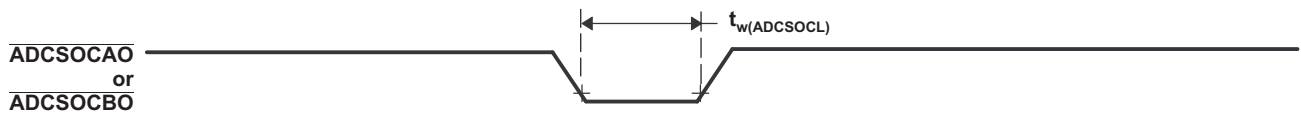

Figure 5-13.  $\overline{ADCSOCAO}$  or  $\overline{ADCSOCBO}$  Timing

### 5.10.2 Comparator + DAC Units

Figure 5-14 shows the internal structure of the six analog Comparator + DAC units present in Concerto devices. Each unit compares two analog inputs (A and B) and assigns a value of '1' when the voltage of the A input is greater than that of the B input, or a value of '0' when the opposite is true. The six A inputs and two B inputs come from AIO\_MUX1 and AIO\_MUX2. All six B inputs can also be provided by the 10-bit digital-to-analog units that are present in each comparator DAC. The 10-bit value for each DAC unit is programmed in the respective DACVAL register. Another comparator register, COMPCTL, can be programmed to select the source of the B input, to enable or disable the comparator circuit, to invert comparator output, to synchronize comparator output to C28x SYSCLK, and to select the qualification period (number of clock cycles). All six output signals from the six comparators can be routed out to the device pins through GPIO\_MUX2 pin mux.

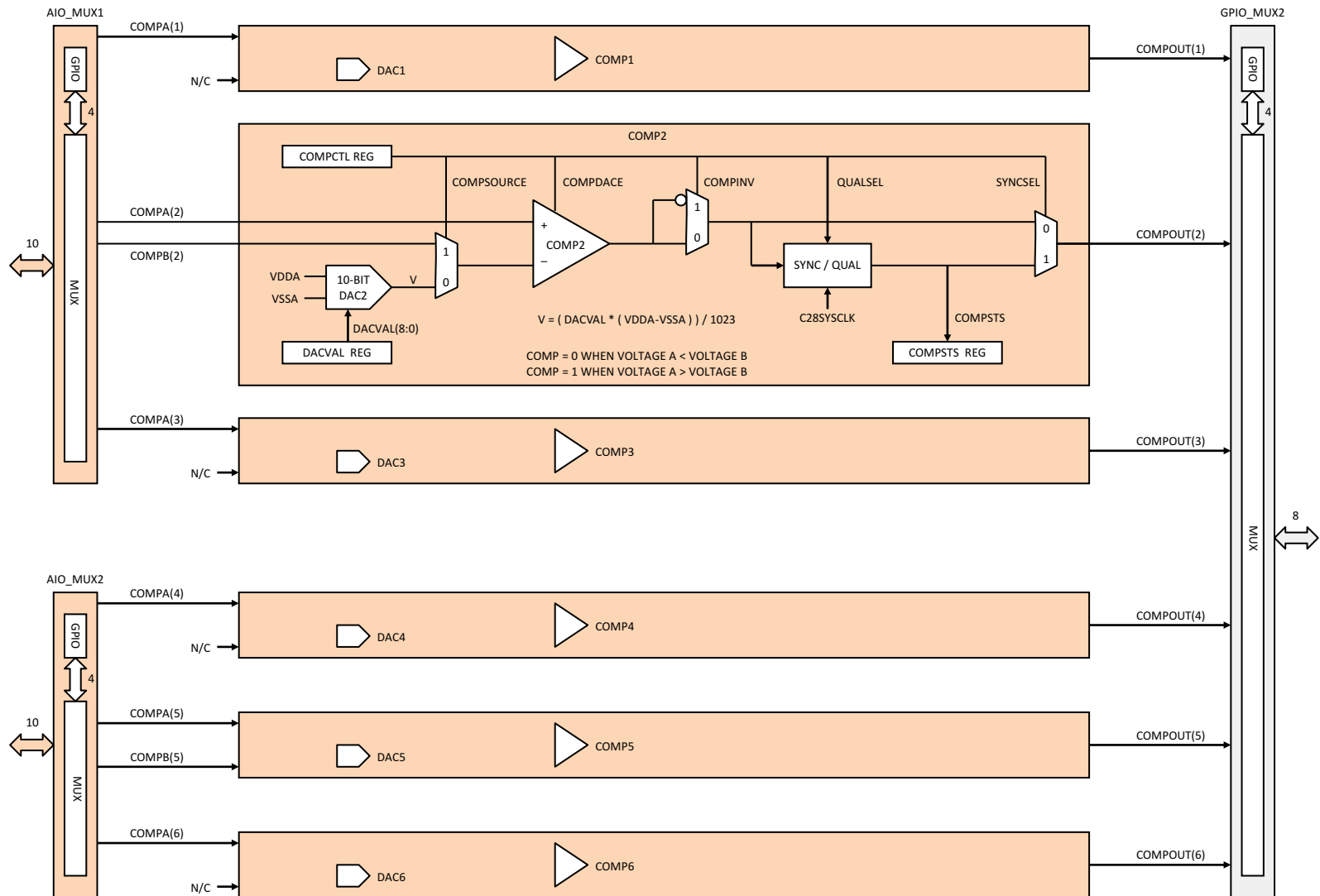

Figure 5-14. Comparator + DAC Units

5.10.2.1 On-Chip Comparator and DAC Electrical Data and Timing

Table 5-40. Electrical Characteristics of the Comparator/DAC

over recommended operating conditions (unless otherwise noted)

| PARAMETER   | MIN | TYP                 | MAX | UNITS |
|---|-----|---------------------|-----|-------|
| <b>Comparator</b>                                 |     |                     |     |       |
| Comparator Input Range                            |     | $V_{SSA} - V_{DDA}$ |     | V     |
| Comparator response time to PWM Trip Zone (Async) |     | 30                  |     | ns    |
| Input Offset                                      |     | $\pm 5$             |     | mV    |
| Input Hysteresis <sup>(1)</sup>                   |     | 35                  |     | mV    |
| <b>DAC</b>  |     |                     |     |       |
| DAC Output Range                                  |     | $V_{SSA} - V_{DDA}$ |     | V     |
| DAC resolution                                    |     | 10                  |     | bits  |
| DAC settling time                                 |     | See Figure 5-15     |     |       |
| DAC Gain  |     | -1.5%               |     |       |
| DAC Offset  |     | 10                  |     | mV    |
| Monotonic   |     | Yes                 |     |       |
| INL   |     | $\pm 3$             |     | LSB   |

(1) Hysteresis on the comparator inputs is achieved with a Schmidt trigger configuration. This results in an effective 100-kΩ feedback resistance between the output of the comparator and the noninverting input of the comparator.

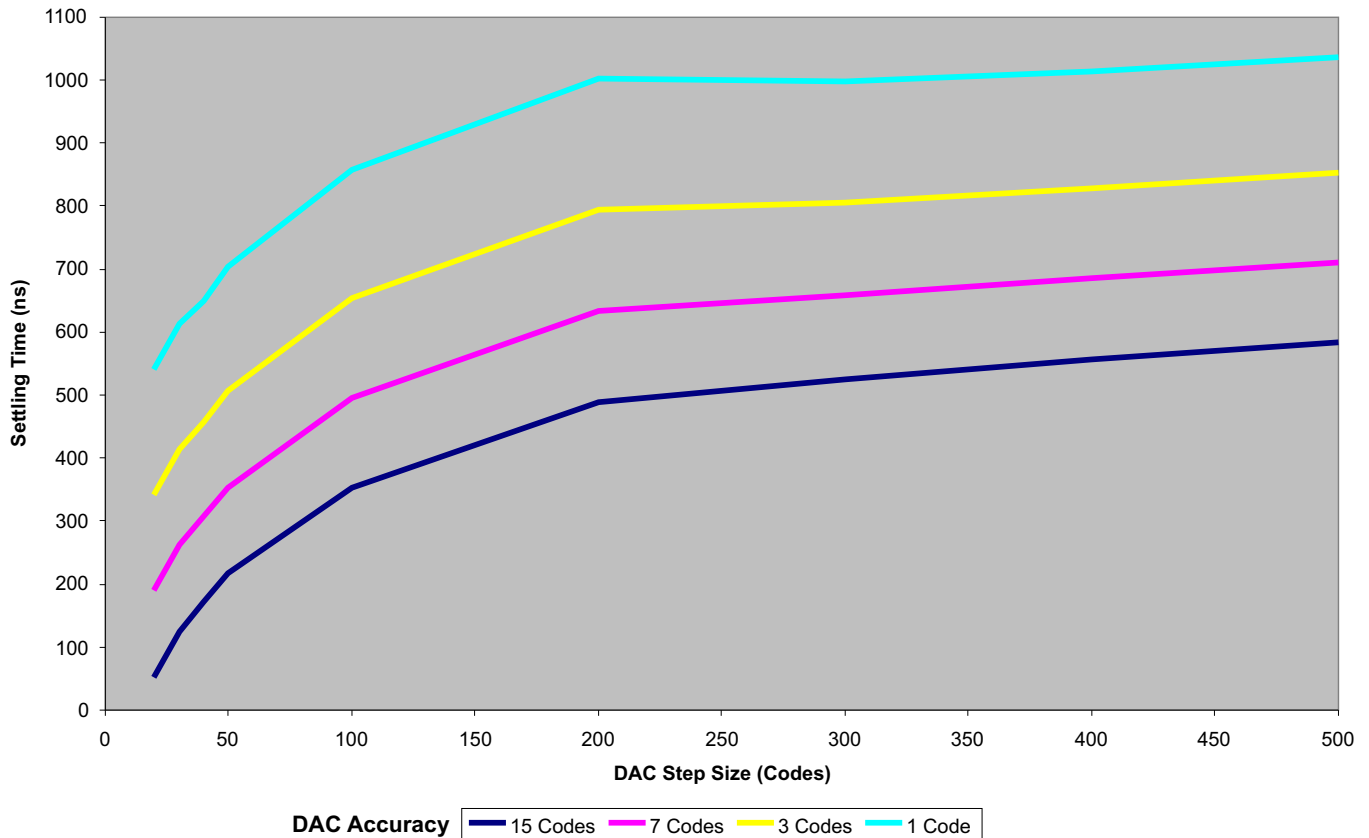

Figure 5-15. DAC Settling Time

### 5.10.3 Interprocessor Communications

Figure 5-16 shows the internal structure of the IPC peripheral used to synchronize program execution and exchange of data between the Cortex-M3 and the C28x CPU. IPC can be used by itself when synchronizing program execution or it can be used in conjunction with Message RAMs when coordinating data transfers between processors. In either case, the operation of the IPC is the same. There are two independent sides to the IPC peripheral—MTOC (Master to Control) and CTOM (Control to Master).

The MTOC IPC is used by the Master Subsystem to send events to the Control Subsystem. The MTOC IPC typically sends events to the Control Subsystem by using the following registers: MTOCIPCSET, MTOCIPCFLG/MTOCIPCSTS <sup>(1)</sup>, and MTOCIPCACK. Each of the 32 bits of these registers represents 32 independent channels through which the Cortex-M3 CPU can send up to 32 events to the C28x CPU through software handshaking. Additionally, the first 4 bits of the MTOCIPC registers are supplemented with interrupts. To send an event through channel 2 from Cortex-M3 to C28x, for example, the Cortex-M3 and C28x CPUs use bit 2 of the MTOCIPCSET, MTOCIPCFLG/MTOCIPCSTS, MTOCIPCACK registers. The handshake starts with the Cortex-M3 polling bit 2 of the MTOCIPCFLG register to make sure bit 2 is '0'. Next, the Cortex-M3 writes a '1' into bit 2 of the MTOCIPCSET register to start the handshake. In the mean time, the C28x is continually polling the MTOCIPCSTS register while waiting for the message. As soon as the Cortex-M3 writes '1' to bit 2 of the MTOCIPCSET register, bit 2 of MTOCIPCFLG/MTOCIPCSTS also turns '1', thus announcing the event to the C28x. As soon as the C28x CPU reads a '1' from the MTOCIPCSTS register, the C28x CPU should acknowledge by writing a '1' to bit 2 of the MTOCIPCACK register, which in turn, clears bit 2 of the MTOCIPCFLG/MTOCIPCSTS register, enabling the Cortex-M3 to send another message. Because the first four channels (bits 0, 1, 2, 3) are backed up by interrupts, both processors in the above example can use IPC interrupt 2 instead of polling to increase performance.

A similar handshake is also used when sending data (not just event) from the Master Subsystem to the Control Subsystem, but with two additional steps. Before setting a bit in the MTOCIPCSET register, the Cortex-M3 should first load the MTOC Message RAM with a block of data that is to be made available to the C28x. In the second additional step, the C28x should read the data before setting a bit in the MTOCIPCACK register. This way, no data gets lost during multiple data transfers through a given block of the message RAM.

The CTOM IPC is used by the Control Subsystem to send events to the Master Subsystem. The CTOM IPC typically sends events to the Master Subsystem by using the following three registers: CTOMIPCSET, CTOMIPCFLG/CTOMIPCSTS, and CTOMIPCACK. The process is exactly the same as that for the MTOC IPC communication above.

(1) Physically, MTOCIPCFLG/MTOCIPCSTS is one register, but it is referred to as the MTOCIPCFLG register when the Cortex-M3 CPU reads it, and as the MTOCIPCSTS register when the C28x CPU reads it.

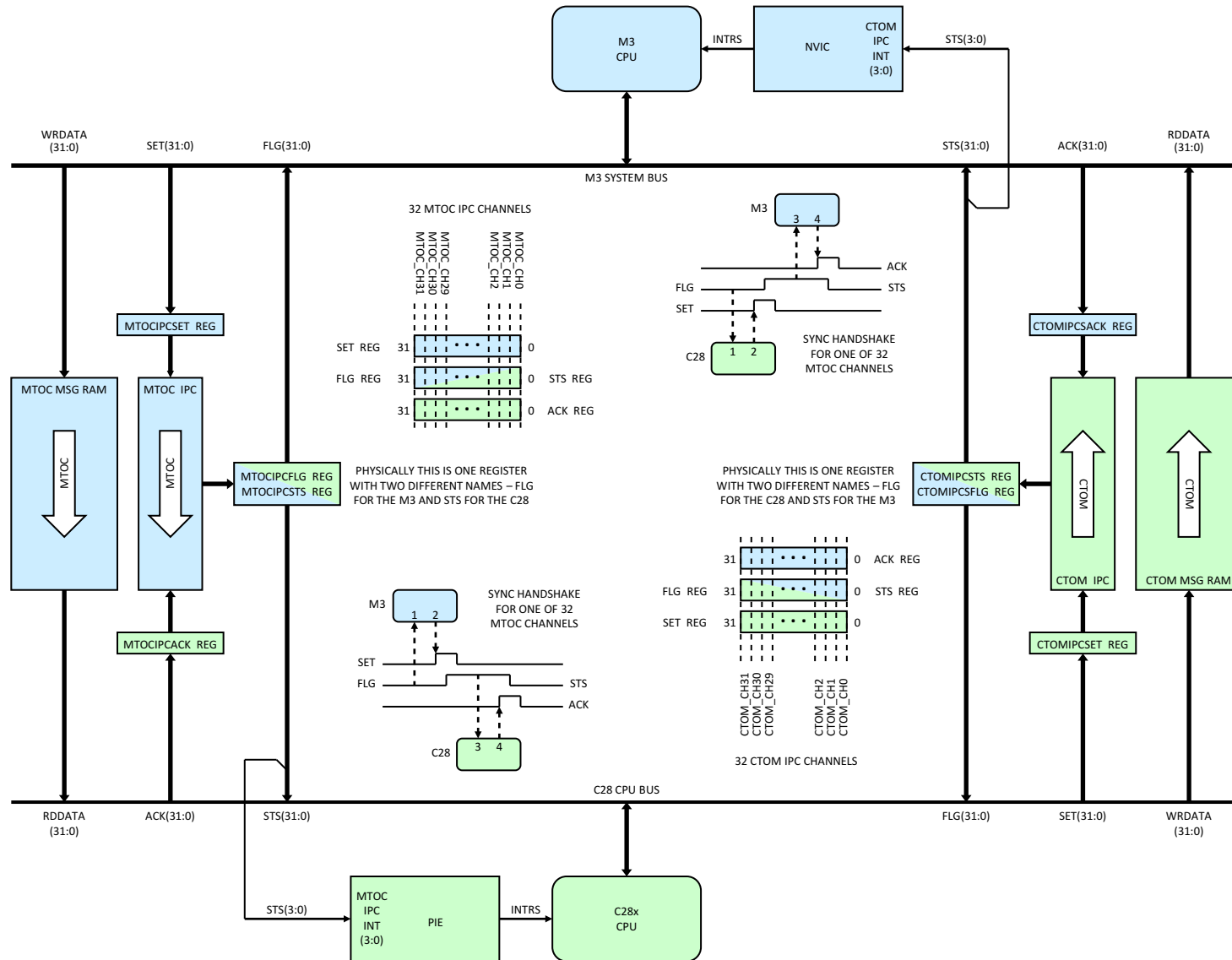

Figure 5-16. IPC

### 5.10.4 External Peripheral Interface

The EPI provides a high-speed parallel bus for interfacing external peripherals and memory. EPI is accessible from both the Master Subsystem and the Control Subsystem. EPI has several modes of operation to enable glueless connectivity to most types of external devices. Some EPI modes of operation conform to standard microprocessor address/data bus protocols, while others are tailored to support a variety of fast custom interfaces, such as those communicating with field-programmable gate arrays (FPGAs) and complex programmable logic devices (CPLDs).

The EPI peripheral can be accessed by the Cortex-M3 CPU, the Cortex-M3 DMA, the C28x CPU, and the C28x DMA over the high-performance AHB bus. The Cortex-M3 CPU and the  $\mu$ DMA drive AHB bus cycles directly through the Cortex-M3 Bus Matrix. The C28x CPU and DMA also connect to the Cortex-M3 Bus Matrix, but not directly. Before entering the Cortex-M3 Bus Matrix, the native C28x CPU and DMA bus cycles are first converted to AHB protocol inside the MEM32-to-AHB Bus Bridge. After that, they pass through the Frequency Gasket to reduce the bus frequency by a factor of 2 or 4. Inside the Cortex-M3 Bus Matrix, the Cortex-M3 bus cycles may have to compete with C28x bus cycles for access to the AHB bus on the way to the EPI peripheral. See [Figure 5-17](#) to see how EPI interfaces to the Concerto Master Subsystem, the Concerto Control Subsystem, Resets, Clocks, and Interrupts.

---

#### NOTE

The Control Subsystem has no direct access to EPI in silicon revision 0 devices.

---

Depending on how the Real-Time Window registers are configured inside the Bus Matrix, the arbitration between the Cortex-M3 and C28x bus cycles is fixed-priority with Cortex-M3 having higher priority than C28x, or the C28x having the option to own the Bus Matrix for a fixed period of time (window)—effectively stalling all Cortex-M3 accesses during that time. Another EPI register inside the Cortex-M3 Bus Matrix is the Memory Protection Register, which enables assignments of chip-select spaces to Cortex-M3 or C28x EPI accesses (or both). The assignments of chip-select spaces prevent a bus cycle (from any processor) that does not own a given chip-select space, from getting through to EPI. The Real-time Window registers are the only EPI-related registers that are configurable by the C28x. The Memory Protection Register is configurable only by the Cortex-M3 CPU, as are all configuration registers inside the EPI peripheral. [Figure 5-17](#) shows the EPI registers and how they relate to individual blocks within the EPI.

Once a bus cycle arrives at the AHB bus interface inside the EPI peripheral, the bus cycle is routed to the General-Purpose Block, SDRAM Block, or the Host Bus Module, depending on the operating mode chosen through the EPI Configuration Register. Write cycles are buffered in a 4-word-deep Write FIFO; therefore, in most cases, the write cycles do not stall the CPU or DMA unless the Write FIFO becomes full. Read cycles can be handled in two different ways: blocking read cycles and nonblocking read cycles. Blocking read cycles are implemented when the content of a Read Data Register is 0. Blocking reads stall the CPU or DMA until the bus transaction completes. Nonblocking read cycles are triggered when a non-zero value is written into a Read Data Register. A non-zero value being written into a Read Data register triggers EPI to autonomously perform multiple data reads in the background (without involving CPU or DMA) according to values stored inside the Read Address Register and the Read Size Register. The incoming data is then temporarily stored in the Non-Blocking Read (NBR) FIFO until an EPI interrupt is generated to prompt the CPU or DMA to read the FIFO without risk of stalling. Furthermore, EPI has actually two sets of Data/Address/Size registers (set 0 and set 1) to enable ping-pong operation of nonblocking reads. In a ping-pong operation, while the previously fetched data is being read by the CPU or DMA from one end of the NBR FIFO, the next set of data words is simultaneously being deposited into the other end of the NBR FIFO.

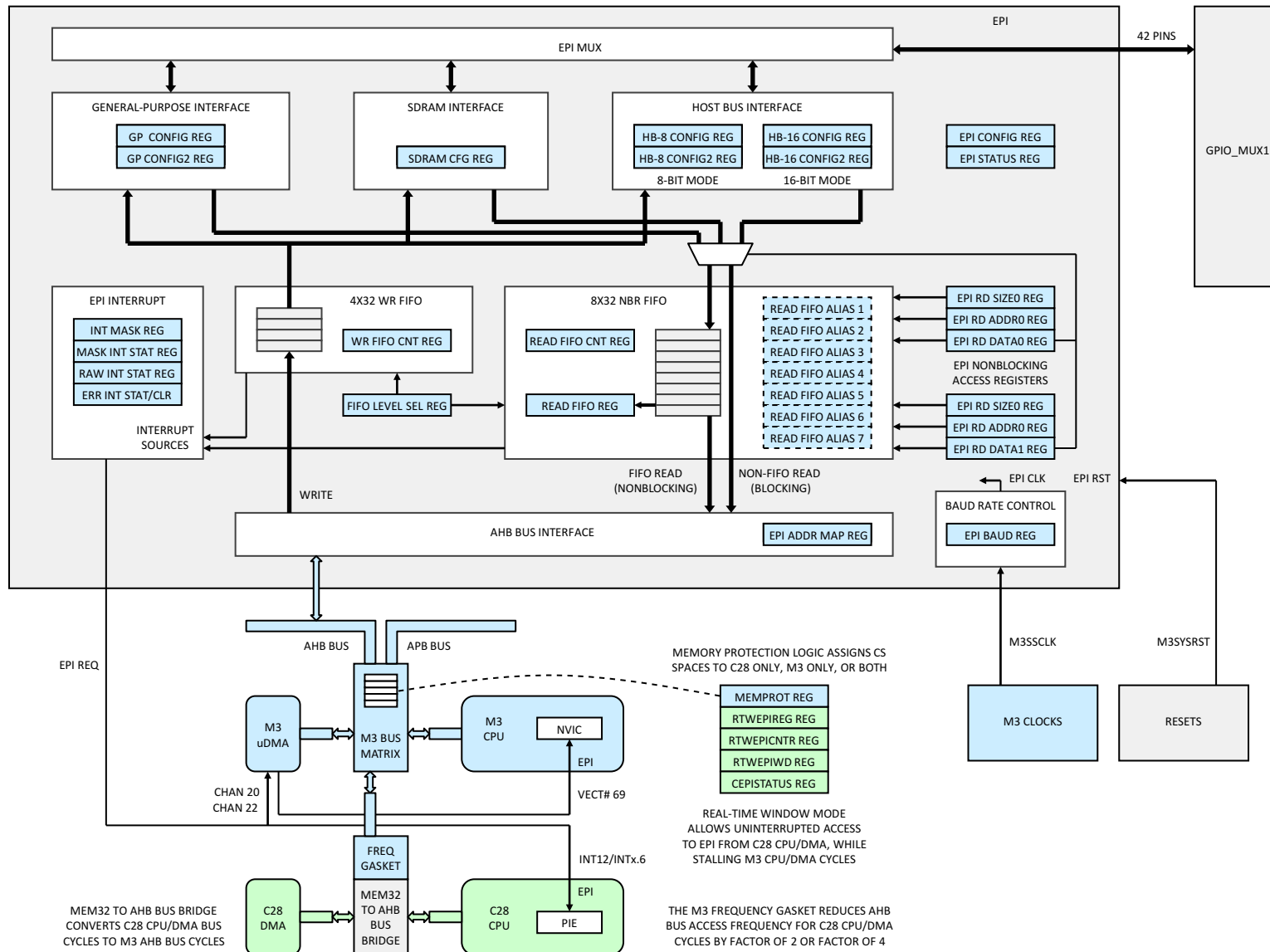

Figure 5-17. EPI

EPI can directly interrupt the Cortex-M3 CPU, the Cortex-M3 uDMA, and the C28x CPU (but not the C28x DMA) through the EPI interrupt. Typically, EPI interrupts are used to prompt the CPU or DMA to move data to and from EPI. There are four EPI Interrupt registers that control various facets of interrupt generation, clearing, and masking. The EPI Interrupt can trigger  $\mu$ DMA to perform reads and writes through DMA Channels 20 and 22. If a CPU is the intended recipient, the Cortex-M3 CPU is interrupted by NVIC vector 69, and the C28x CPU is interrupted through the INT12/INTx6 vector to the PIE.

During EPI bus cycles, addresses entering the EPI module can propagate unchanged to the pins, or be remapped to different addresses according to values stored in the EPI Address Map Register in conjunction with the most significant bit of the incoming address.

The EPI's three primary operating modes are: the General-Purpose Mode, the SDRAM Mode, and the Host Bus Mode (including 8-bit and 16-bit versions).

#### 5.10.4.1 EPI General-Purpose Mode

The EPI General-Purpose Mode is designed for high-speed clocked interfaces such as ones communicating with FPGAs and CPLDs. The high-speed clocked interfaces are different from the slower Host Bus interfaces, which have more relaxed timings that are compatible with established protocols like ones used to communicate with 8051 devices. Support of bus cycle framing and precisely controlled clocking are the additional features of the General-Purpose Mode that differentiate the General-Purpose Mode from the 8-bit and 16-bit Host Bus Modes.

Framing allows multiple bus transactions to be grouped together with an output signal called FRAME. The slave device responding to the bus cycles may use this signal to recognize related words of data and to speed up their transfers. The frame lengths are programmable and may vary from 1 to 30 clocks, depending on the clocking mode used.

Precise clocking is accomplished with a dedicated clock output pin (CLK). Devices responding the bus cycles can synchronize to CLK for faster transfers. The clock frequency can be precisely controlled through the Baud Rate Control block. This output clock can be gated or free-running. A gated approach uses a setup-time model in which the EPI clock controls when bus transactions are starting and stopping. A free-running EPI clock requires another method for determining when data is live, such as the frame pin or RD/WR strobes.

These and numerous other aspects of the General-Purpose Mode are controlled through the General-Purpose Configuration Register and the General-Purpose Configuration2 Register. The clocking for the General-Purpose Mode is configured through the EPI Baud Register of the EPI Baud Rate Control block.

See [Figure 5-18](#) for a snapshot of the General-Purpose Mode registers, modes, and features. For more detailed maps of the General-Purpose Mode, see [Table 5-41](#).

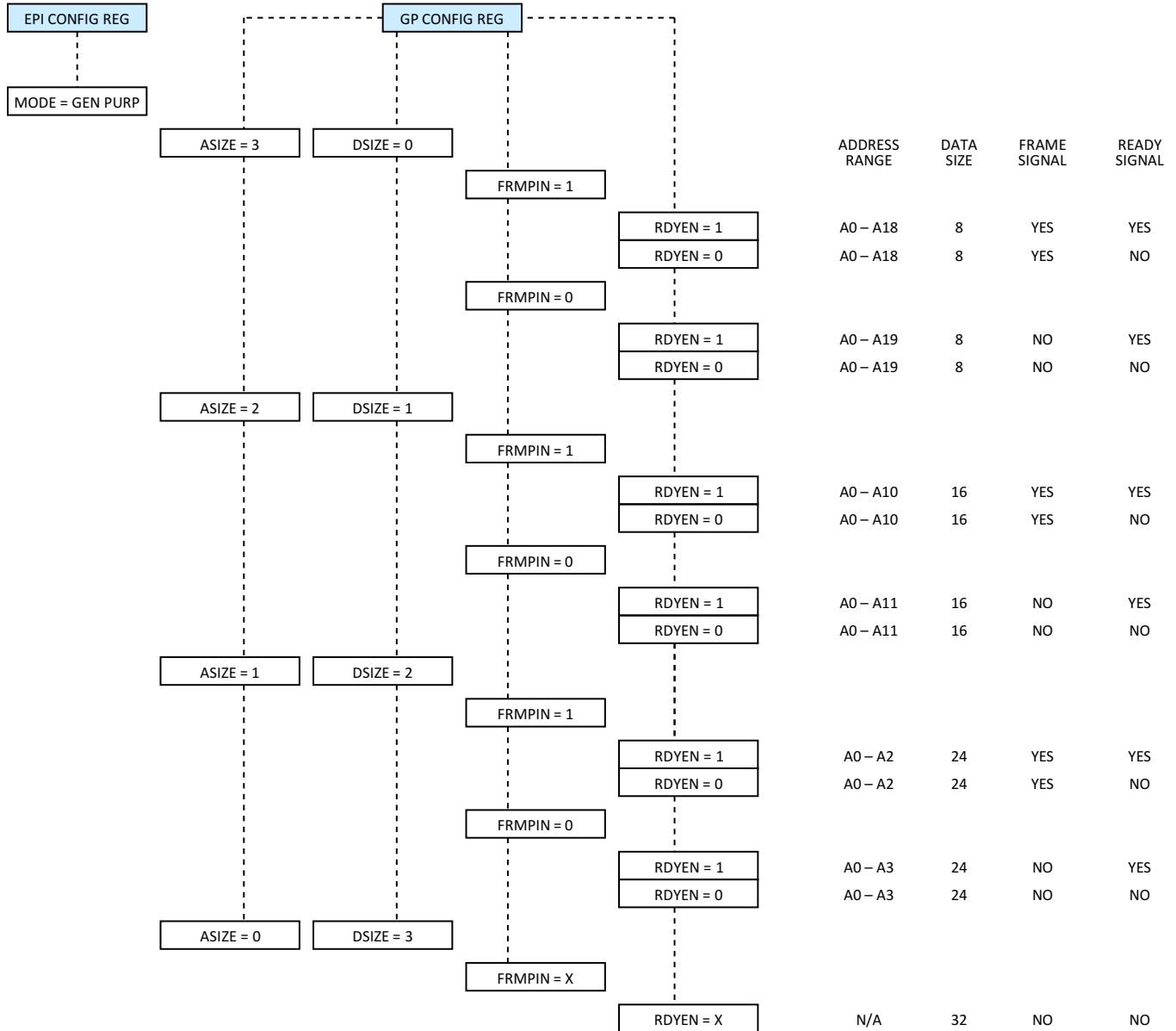

Figure 5-18. EPI General-Purpose Modes

**Table 5-41. EPI MODES – General-Purpose Mode (EPICFG/MODE = 0x0)**

| EPI PORT NAME           |                    | EPI SIGNAL FUNCTION              |                                   |                                  |                                       | DEVICE PIN                                   |            |
|-------------------------|--------------------|----------------------------------|-----------------------------------|----------------------------------|---------------------------------------|--|------------|
| ACCESSIBLE BY Cortex-M3 | ACCESSIBLE BY C28x | GENERAL-PURPOSE SIGNAL (D8, A20) | GENERAL-PURPOSE SIGNAL (D16, A12) | GENERAL-PURPOSE SIGNAL (D24, A4) | GENERAL-PURPOSE SIGNAL (D30, NO ADDR) | (AVAILABLE GPIOMUX_1 MUXING CHOICES FOR EPI) |            |
|                         | EPI0S0             | D0                               | D0                                | D0                               | D0                                    | PH3_GPIO51                                   |            |
|                         | EPI0S1             | D1                               | D1                                | D1                               | D1                                    | PH2_GPIO50                                   |            |
|                         | EPI0S2             | D2                               | D2                                | D2                               | D2                                    | PC4_GPIO68                                   |            |
|                         | EPI0S3             | D3                               | D3                                | D3                               | D3                                    | PC5_GPIO69                                   |            |
|                         | EPI0S4             | D4                               | D4                                | D4                               | D4                                    | PC6_GPIO70                                   |            |
|                         | EPI0S5             | D5                               | D5                                | D5                               | D5                                    | PC7_GPIO71                                   |            |
|                         | EPI0S6             | D6                               | D6                                | D6                               | D6                                    | PH0_GPIO48                                   |            |
|                         | EPI0S7             | D7                               | D7                                | D7                               | D7                                    | PH1_GPIO49                                   |            |
|                         | EPI0S8             | A0                               | D8                                | D8                               | D8                                    | PE0_GPIO24                                   |            |
|                         | EPI0S9             | A1                               | D9                                | D9                               | D9                                    | PE1_GPIO25                                   |            |
|                         | EPI0S10            | A2                               | D10                               | D10                              | D10                                   | PH4_GPIO52                                   |            |
|                         | EPI0S11            | A3                               | D11                               | D11                              | D11                                   | PH5_GPIO53                                   |            |
|                         | EPI0S12            | A4                               | D12                               | D12                              | D12                                   | PF4_GPIO36                                   |            |
|                         | EPI0S13            | A5                               | D13                               | D13                              | D13                                   | PG0_GPIO40                                   |            |
|                         | EPI0S14            | A6                               | D14                               | D14                              | D14                                   | PG1_GPIO41                                   |            |
|                         | EPI0S15            | A7                               | D15                               | D15                              | D15                                   | PF5_GPIO37                                   |            |
|                         | EPI0S16            | A8                               | A0                                | D16                              | D16                                   | PJ0_GPIO56                                   |            |
|                         | EPI0S17            | A9                               | A1                                | D17                              | D17                                   | PJ1_GPIO57                                   |            |
|                         | EPI0S18            | A10                              | A2                                | D18                              | D18                                   | PJ2_GPIO58                                   |            |
|                         | EPI0S19            | A11                              | A3                                | D19                              | D19                                   | PD4_GPIO20                                   | PJ3_GPIO59 |
|                         | EPI0S20            | A12                              | A4                                | D29                              | D29                                   | PD2_GPIO18                                   |            |
|                         | EPI0S21            | A13                              | A5                                | D21                              | D21                                   | PD3_GPIO19                                   |            |
|                         | EPI0S22            | A14                              | A6                                | D22                              | D22                                   | PB5_GPIO13                                   |            |
|                         | EPI0S23            | A15                              | A7                                | D23                              | D23                                   | PB4_GPIO12                                   |            |
|                         | EPI0S24            | A16                              | A8                                | A0                               | D24                                   | PE2_GPIO26                                   |            |
|                         | EPI0S25            | A17                              | A9                                | A1                               | D25                                   | PE3_GPIO27                                   |            |
|                         | EPI0S26            | A18                              | A10                               | A2                               | D26                                   | PH6_GPIO54                                   |            |
|                         | EPI0S27            | A19/RDY                          | A11/RDY                           | A3/RDY                           | D27                                   | PH7_GPIO55                                   |            |
|                         | EPI0S28            | WR                               | WR                                | WR                               | D28                                   | PD5_GPIO21                                   | PJ4_GPIO60 |
|                         | EPI0S29            | RD                               | RD                                | RD                               | D29                                   | PD6_GPIO22                                   | PJ5_GPIO61 |
|                         | EPI0S30            | FRAME                            | FRAME                             | FRAME                            | D30                                   | PD7_GPIO23                                   | PJ6_GPIO62 |
|                         | EPI0S31            | CLK                              | CLK                               | CLK                              | D31                                   | PG7_GPIO47                                   |            |
|                         | EPI0S32            | x                                | x                                 | x                                | x                                     | PF2_GPIO34                                   | PC0_GPIO64 |
|                         | EPI0S33            | x                                | x                                 | x                                | x                                     | PF3_GPIO35                                   | PC1_GPIO65 |
|                         | EPI0S34            | x                                | x                                 | x                                | x                                     | PE4_GPIO28                                   |            |
|                         | EPI0S35            | x                                | x                                 | x                                | x                                     | PE5_GPIO29                                   |            |
|                         | EPI0S36            | x                                | x                                 | x                                | x                                     | PB7_GPIO15                                   | PC3_GPIO67 |
|                         | EPI0S37            | x                                | x                                 | x                                | x                                     | PB6_GPIO14                                   | PC2_GPIO66 |
|                         | EPI0S38            | x                                | x                                 | x                                | x                                     | PF6_GPIO38                                   | PE4_GPIO28 |
|                         | EPI0S39            | x                                | x                                 | x                                | x                                     | PG2_GPIO42                                   |            |
|                         | EPI0S40            | x                                | x                                 | x                                | x                                     | PG5_GPIO45                                   |            |
|                         | EPI0S41            | x                                | x                                 | x                                | x                                     | PG6_GPIO46                                   |            |

### 5.10.4.2 EPI SDRAM Mode

The EPI SDRAM Mode combines high performance, low cost, and low pin use to access up to 512 megabits (Mb) of external memory. Main features of the EPI SDRAM interface are:

- Supports x16 (single data rate) SDRAM
- Supports low-cost SDRAMs up to 64 megabytes (MB) [or 512Mb]
- Includes automatic refresh and access to all banks, rows
- Includes Sleep/STANDBY Mode to keep contents active with minimal power drain
- Multiplexed address/data interface for reduced pin count

See [Figure 5-19](#) for a snapshot of the SDRAM Mode registers and supported memory sizes. For more detailed maps of the SDRAM Mode, see [Table 5-42](#).

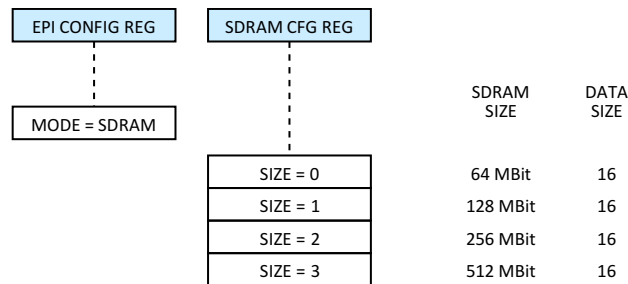

**Figure 5-19. EPI SDRAM Mode**

**Table 5-42. EPI MODES – SDRAM Mode (EPICFG/MODE = 0x1)**

| EPI PORT NAME           |                    | EPI SIGNAL FUNCTION |                         | DEVICE PIN                                   |
|-------------------------|--------------------|---------------------|-------------------------|--|
| ACCESSIBLE BY Cortex-M3 | ACCESSIBLE BY C28x | COLUMN/ROW ADDRESS  | DATA                    | (AVAILABLE GPIOMUX_1 MUXING CHOICES FOR EPI) |
|                         | EPI0S0             | A0                  | D0                      | PH3_GPIO51                                   |
|                         | EPI0S1             | A1                  | D1                      | PH2_GPIO50                                   |
|                         | EPI0S2             | A2                  | D2                      | PC4_GPIO68                                   |
|                         | EPI0S3             | A3                  | D3                      | PC5_GPIO69                                   |
|                         | EPI0S4             | A4                  | D4                      | PC6_GPIO70                                   |
|                         | EPI0S5             | A5                  | D5                      | PC7_GPIO71                                   |
|                         | EPI0S6             | A6                  | D6                      | PH0_GPIO48                                   |
|                         | EPI0S7             | A7                  | D7                      | PH1_GPIO49                                   |
|                         | EPI0S8             | A8                  | D8                      | PE0_GPIO24                                   |
|                         | EPI0S9             | A9                  | D9                      | PE1_GPIO25                                   |
|                         | EPI0S10            | A10                 | D10                     | PH4_GPIO52                                   |
|                         | EPI0S11            | A11                 | D11                     | PH5_GPIO53                                   |
|                         | EPI0S12            | A12                 | D12                     | PF4_GPIO36                                   |
|                         | EPI0S13            | BA0                 | D13                     | PG0_GPIO40                                   |
|                         | EPI0S14            | BA1                 | D14                     | PG1_GPIO41                                   |
|                         |                    |                     |                         |  |
|                         | EPI0S15            |                     | D15                     | PF5_GPIO37                                   |
|                         | EPI0S16            |                     | DQML                    | PJ0_GPIO56                                   |
|                         | EPI0S17            |                     | DQMH                    | PJ1_GPIO57                                   |
|                         | EPI0S18            |                     | $\overline{\text{CAS}}$ | PJ2_GPIO58                                   |
|                         | EPI0S19            |                     | $\overline{\text{RAS}}$ | PD4_GPIO20 PJ3_GPIO59                        |
|                         | EPI0S28            |                     | $\overline{\text{WE}}$  | PD5_GPIO21 PJ4_GPIO60                        |
|                         | EPI0S29            |                     | $\overline{\text{CS}}$  | PD6_GPIO22 PJ5_GPIO61                        |
|                         | EPI0S30            |                     | CKE                     | PD7_GPIO23 PJ6_GPIO62                        |
|                         | EPI0S31            |                     | CLK                     | PG7_GPIO47                                   |
|                         |                    |                     |                         |  |
|                         | EPI0S20            |                     | x                       | PD2_GPIO18                                   |
|                         | EPI0S21            |                     | x                       | PD3_GPIO19                                   |
|                         | EPI0S22            |                     | x                       | PB5_GPIO13                                   |
|                         | EPI0S23            |                     | x                       | PB4_GPIO12                                   |
|                         | EPI0S24            |                     | x                       | PE2_GPIO26                                   |
|                         | EPI0S25            |                     | x                       | PE3_GPIO27                                   |
|                         | EPI0S26            |                     | x                       | PH6_GPIO54                                   |
|                         | EPI0S27            |                     | x                       | PH7_GPIO55                                   |
|                         |                    |                     |                         |  |
|                         | EPI0S32            |                     | x                       | PF2_GPIO34 PC0_GPIO64                        |
|                         | EPI0S33            |                     | x                       | PF3_GPIO35 PC1_GPIO65                        |
|                         | EPI0S34            |                     | x                       | PE4_GPIO28                                   |
|                         | EPI0S35            |                     | x                       | PE5_GPIO29                                   |
|                         | EPI0S36            |                     | x                       | PB7_GPIO15 PC3_GPIO67                        |
|                         | EPI0S37            |                     | x                       | PB6_GPIO14 PC2_GPIO66                        |
|                         | EPI0S38            |                     | x                       | PF6_GPIO38 PE4_GPIO28                        |
|                         | EPI0S39            |                     | x                       | PG2_GPIO42                                   |
|                         | EPI0S40            |                     | x                       | PG5_GPIO45                                   |
|                         | EPI0S41            |                     | x                       | PG6_GPIO46                                   |

### 5.10.4.3 EPI Host Bus Mode

There are two versions of the EPI Host Bus Mode: an 8-bit version (HB-8) and a 16-bit version (HB-16). [Section 5.10.4.3.1](#) discusses the EPI 8-Bit Host Bus Mode. [Section 5.10.4.3.2](#) discusses the EPI 16-Bit Host Bus Mode.

#### 5.10.4.3.1 EPI 8-Bit Host Bus (HB-8) Mode

The 8-Bit Host Bus (HB-8) Mode uses fewer data pins than the 16-Bit Host Bus (HB-16) Mode; hence, more pins are available for address. The HB-8 Mode is also slower than the General-Purpose Mode in order to accommodate older logic. The HB-8 Mode is selected with the MODE field of EPI Configuration Register. Within the HB-8 Mode, two additional registers are used to select address/data muxing, chip selects, and other options. These registers are the HB-8 Configuration Register and the HB-8 Configuration2 Register. See [Figure 5-20](#) for a snapshot of HB-8 registers, modes, and features.

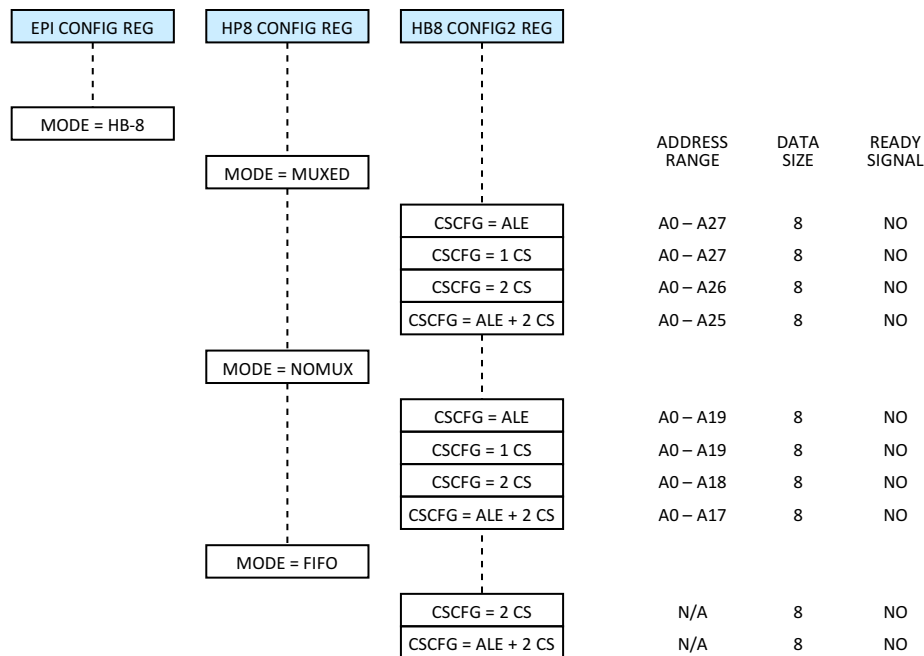

**Figure 5-20. EPI 8-Bit Host Bus Mode**

#### 5.10.4.3.1.1 HB-8 Muxed Address/Data Mode

The HB-8 Muxed Mode multiplexes address signals with low-order data signals. For this reason, the Muxed Mode allows for a larger address space as compared to the Non-Muxed Mode. The HB-8 Muxed Mode is selected with the MODE field of the HB-8 Configuration Register. In addition to data and address signals, the HB-8 Muxed Mode also features the ALE signal (indicating to an external latch to capture address and hold the address until the data phase); RD and WR data strobes; and 1–4 CS (Chip Select) signals to enable one of four external peripherals. The ALE and CS options are chosen with the CSCFG field of the HB-8 Configuration2 Register. For more detailed maps of the HB-8 Muxed Mode, see [Table 5-43](#).

**Table 5-43. EPI MODES – 8-Bit Host-Bus Mode (EPICFG/MODE = 0x2), Muxed (EPIHB16CFG/MODE = 0x0)**

| EPI PORT NAME           |                    | EPI SIGNAL FUNCTION                     |                                    |                                     |   | DEVICE PIN                                   |            |
|-------------------------|--------------------|---|------------------------------------|-------------------------------------|---|--|------------|
| ACCESSIBLE BY Cortex-M3 | ACCESSIBLE BY C28x | WITH ADDRESS LATCH ENABLE (CSCFG = 0x0) | WITH ONE CHIP SELECT (CSCFG = 0x1) | WITH TWO CHIP SELECTS (CSCFG = 0x2) | WITH ALE AND TWO CHIP SELECTS (CSCFG = 0x3) | (AVAILABLE GPIOMUX_1 MUXING CHOICES FOR EPI) |            |
|                         | EPIOS0             | AD0                                     | AD0                                | AD0                                 | AD0   | PH3_GPIO51                                   |            |
|                         | EPIOS1             | AD1                                     | AD1                                | AD1                                 | AD1   | PH2_GPIO50                                   |            |
|                         | EPIOS2             | AD2                                     | AD2                                | AD2                                 | AD2   | PC4_GPIO68                                   |            |
|                         | EPIOS3             | AD3                                     | AD3                                | AD3                                 | AD3   | PC5_GPIO69                                   |            |
|                         | EPIOS4             | AD4                                     | AD4                                | AD4                                 | AD4   | PC6_GPIO70                                   |            |
|                         | EPIOS5             | AD5                                     | AD5                                | AD5                                 | AD5   | PC7_GPIO71                                   |            |
|                         | EPIOS6             | AD6                                     | AD6                                | AD6                                 | AD6   | PH0_GPIO48                                   |            |
|                         | EPIOS7             | AD7                                     | AD7                                | AD7                                 | AD7   | PH1_GPIO49                                   |            |
|                         | EPIOS8             | A8                                      | A8                                 | A8                                  | A8  | PE0_GPIO24                                   |            |
|                         | EPIOS9             | A9                                      | A9                                 | A9                                  | A9  | PE1_GPIO25                                   |            |
|                         | EPIOS10            | A10                                     | A10                                | A10                                 | A10   | PH4_GPIO52                                   |            |
|                         | EPIOS11            | A11                                     | A11                                | A11                                 | A11   | PH5_GPIO53                                   |            |
|                         | EPIOS12            | A12                                     | A12                                | A12                                 | A12   | PF4_GPIO36                                   |            |
|                         | EPIOS13            | A13                                     | A13                                | A13                                 | A13   | PG0_GPIO40                                   |            |
|                         | EPIOS14            | A14                                     | A14                                | A14                                 | A14   | PG1_GPIO41                                   |            |
|                         | EPIOS15            | A15                                     | A15                                | A15                                 | A15   | PF5_GPIO37                                   |            |
|                         | EPIOS16            | A16                                     | A16                                | A16                                 | A16   | PJ0_GPIO56                                   |            |
|                         | EPIOS17            | A17                                     | A17                                | A17                                 | A17   | PJ1_GPIO57                                   |            |
|                         | EPIOS18            | A18                                     | A18                                | A18                                 | A18   | PJ2_GPIO58                                   |            |
|                         | EPIOS19            | A19                                     | A19                                | A19                                 | A19   | PD4_GPIO20                                   | PJ3_GPIO59 |
|                         | EPIOS20            | A20                                     | A20                                | A20                                 | A20   | PD2_GPIO18                                   |            |
|                         | EPIOS21            | A21                                     | A21                                | A21                                 | A21   | PD3_GPIO19                                   |            |
|                         | EPIOS22            | A22                                     | A22                                | A22                                 | A22   | PB5_GPIO13                                   |            |
|                         | EPIOS23            | A23                                     | A23                                | A23                                 | A23   | PB4_GPIO12                                   |            |
|                         | EPIOS24            | A24                                     | A24                                | A24                                 | A24   | PE2_GPIO26                                   |            |
|                         | EPIOS25            | A25                                     | A25                                | A25                                 | A25   | PE3_GPIO27                                   |            |
|                         | EPIOS26            | A26                                     | A26                                | A26                                 | $\overline{CS0}$                            | PH6_GPIO54                                   |            |
|                         | EPIOS27            | A27                                     | A27                                | A27                                 | $\overline{CS1}$                            | PH7_GPIO55                                   |            |
|                         | EPIOS30            | ALE                                     | $\overline{CS0}$                   | $\overline{CS0}$                    | ALE   | PD7_GPIO23                                   | PJ6_GPIO62 |
|                         | EPIOS29            | WR                                      | WR                                 | WR                                  | WR  | PD6_GPIO22                                   | PJ5_GPIO61 |
|                         | EPIOS28            | RD                                      | RD                                 | RD                                  | RD  | PD5_GPIO21                                   | PJ4_GPIO60 |
|                         | EPIOS31            | x                                       | x                                  | x                                   | x   | PG7_GPIO47                                   |            |
|                         | EPIOS32            | x                                       | x                                  | x                                   | x   | PF2_GPIO34                                   | PC0_GPIO64 |
|                         | EPIOS33            | x                                       | x                                  | x                                   | x   | PF3_GPIO35                                   | PC1_GPIO65 |
|                         | EPIOS34            | x                                       | x                                  | x                                   | x   | PE4_GPIO28                                   |            |
|                         | EPIOS35            | x                                       | x                                  | x                                   | x   | PE5_GPIO29                                   |            |
|                         | EPIOS36            | x                                       | x                                  | x                                   | x   | PB7_GPIO15                                   | PC3_GPIO67 |
|                         | EPIOS37            | x                                       | x                                  | x                                   | x   | PB6_GPIO14                                   | PC2_GPIO66 |
|                         | EPIOS38            | x                                       | x                                  | x                                   | x   | PF6_GPIO38                                   | PE4_GPIO28 |
|                         | EPIOS39            | x                                       | x                                  | x                                   | x   | PG2_GPIO42                                   |            |
|                         | EPIOS40            | x                                       | x                                  | x                                   | x   | PG5_GPIO45                                   |            |
|                         | EPIOS41            | x                                       | x                                  | x                                   | x   | PG6_GPIO46                                   |            |

**5.10.4.3.1.2 HB-8 Non-Muxed Address/Data Mode**

The HB-8 Non-Muxed Mode uses dedicated pins for address and data signals. For this reason, the Non-Muxed Mode has reduced address reach as compared to the Muxed Mode. The HB-8 Non-Muxed Mode is selected with the MODE field of the HB-8 Configuration Register. In addition to data and address signals, the HB-8 Non-Muxed Mode also features the ALE signal (indicating to an external latch to capture address and hold the address until the data phase); RD and WR data strobes; and 1–4 CS (Chip Select) signals to enable one of four external peripherals. The ALE and CS options are chosen with the CSCFG field of the HB-8 Configuration2 Register. For more detailed maps of the HB-8 Non-Muxed Mode, see [Table 5-44](#).

**Table 5-44. EPI MODES – 8-Bit Host-Bus Mode (EPICFG/MODE = 0x2), Non-Muxed (EPIHB16CFG/MODE = 0x1)**

| EPI PORT NAME           |                    | EPI SIGNAL FUNCTION                     |                                    |                                     |   | DEVICE PIN                                   |            |
|-------------------------|--------------------|---|------------------------------------|-------------------------------------|---|--|------------|
| ACCESSIBLE BY Cortex-M3 | ACCESSIBLE BY C28x | WITH ADDRESS LATCH ENABLE (CSCFG = 0x0) | WITH ONE CHIP SELECT (CSCFG = 0x1) | WITH TWO CHIP SELECTS (CSCFG = 0x2) | WITH ALE AND TWO CHIP SELECTS (CSCFG = 0x3) | (AVAILABLE GPIOMUX_1 MUXING CHOICES FOR EPI) |            |
|                         | EPIOS0             | D0                                      | D0                                 | D0                                  | D0  | PH3_GPIO51                                   |            |
|                         | EPIOS1             | D1                                      | D1                                 | D1                                  | D1  | PH2_GPIO50                                   |            |
|                         | EPIOS2             | D2                                      | D2                                 | D2                                  | D2  | PC4_GPIO68                                   |            |
|                         | EPIOS3             | D3                                      | D3                                 | D3                                  | D3  | PC5_GPIO69                                   |            |
|                         | EPIOS4             | D4                                      | D4                                 | D4                                  | D4  | PC6_GPIO70                                   |            |
|                         | EPIOS5             | D5                                      | D5                                 | D5                                  | D5  | PC7_GPIO71                                   |            |
|                         | EPIOS6             | D6                                      | D6                                 | D6                                  | D6  | PH0_GPIO48                                   |            |
|                         | EPIOS7             | D7                                      | D7                                 | D7                                  | D7  | PH1_GPIO49                                   |            |
|                         | EPIOS8             | A0                                      | A0                                 | A0                                  | A0  | PE0_GPIO24                                   |            |
|                         | EPIOS9             | A1                                      | A1                                 | A1                                  | A1  | PE1_GPIO25                                   |            |
|                         | EPIOS10            | A2                                      | A2                                 | A2                                  | A2  | PH4_GPIO52                                   |            |
|                         | EPIOS11            | A3                                      | A3                                 | A3                                  | A3  | PH5_GPIO53                                   |            |
|                         | EPIOS12            | A4                                      | A4                                 | A4                                  | A4  | PF4_GPIO36                                   |            |
|                         | EPIOS13            | A5                                      | A5                                 | A5                                  | A5  | PG0_GPIO40                                   |            |
|                         | EPIOS14            | A6                                      | A6                                 | A6                                  | A6  | PG1_GPIO41                                   |            |
|                         | EPIOS15            | A7                                      | A7                                 | A7                                  | A7  | PF5_GPIO37                                   |            |
|                         | EPIOS16            | A8                                      | A8                                 | A8                                  | A8  | PJ0_GPIO56                                   |            |
|                         | EPIOS17            | A9                                      | A9                                 | A9                                  | A9  | PJ1_GPIO57                                   |            |
|                         | EPIOS18            | A10                                     | A10                                | A10                                 | A10   | PJ2_GPIO58                                   |            |
|                         | EPIOS19            | A11                                     | A11                                | A11                                 | A11   | PD4_GPIO20                                   | PJ3_GPIO59 |
|                         | EPIOS20            | A12                                     | A12                                | A12                                 | A12   | PD2_GPIO18                                   |            |
|                         | EPIOS21            | A13                                     | A13                                | A13                                 | A13   | PD3_GPIO19                                   |            |
|                         | EPIOS22            | A14                                     | A14                                | A14                                 | A14   | PB5_GPIO13                                   |            |
|                         | EPIOS23            | A15                                     | A15                                | A15                                 | A15   | PB4_GPIO12                                   |            |
|                         | EPIOS24            | A16                                     | A16                                | A16                                 | A16   | PE2_GPIO26                                   |            |
|                         | EPIOS25            | A17                                     | A17                                | A17                                 | A17   | PE3_GPIO27                                   |            |
|                         | EPIOS26            | A18                                     | A18                                | A18                                 | $\overline{CS0}$                            | PH6_GPIO54                                   |            |
|                         | EPIOS27            | A19                                     | A19                                | A19                                 | $\overline{CS1}$                            | PH7_GPIO55                                   |            |
|                         | EPIOS30            | ALE                                     | $\overline{CS0}$                   | $\overline{CS0}$                    | ALE   | PD7_GPIO23                                   | PJ6_GPIO62 |
|                         | EPIOS29            | WR                                      | WR                                 | WR                                  | WR  | PD6_GPIO22                                   | PJ5_GPIO61 |
|                         | EPIOS28            | RD                                      | RD                                 | RD                                  | RD  | PD5_GPIO21                                   | PJ4_GPIO60 |
|                         | EPIOS31            | x                                       | x                                  | x                                   | x   | PG7_GPIO47                                   |            |
|                         | EPIOS32            | x                                       | x                                  | x                                   | x   | PF2_GPIO34                                   | PC0_GPIO64 |
|                         | EPIOS33            | x                                       | x                                  | x                                   | x   | PF3_GPIO35                                   | PC1_GPIO65 |

**Table 5-44. EPI MODES – 8-Bit Host-Bus Mode (EPICFG/MODE = 0x2),  
Non-Muxed (EPIHB16CFG/MODE = 0x1) (continued)**

| EPI PORT NAME              |                       | EPI SIGNAL FUNCTION                              |   |  |  | DEVICE PIN                                      |
|----------------------------|-----------------------|--|---|--|--|---|
| ACCESSIBLE BY<br>Cortex-M3 | ACCESSIBLE BY<br>C28x | WITH<br>ADDRESS<br>LATCH ENABLE<br>(CSCFG = 0x0) | WITH<br>ONE<br>CHIP SELECT<br>(CSCFG = 0x1) | WITH<br>TWO<br>CHIP SELECTS<br>(CSCFG = 0x2) | WITH<br>ALE AND TWO<br>CHIP SELECTS<br>(CSCFG = 0x3) | (AVAILABLE GPIOMUX_1<br>MUXING CHOICES FOR EPI) |
|                            | EPI0S34               | x  | x   | x  | x  | PE4_GPIO28                                      |
|                            | EPI0S35               | x  | x   | x  | x  | PE5_GPIO29                                      |
|                            | EPI0S36               | x  | x   | x  | x  | PB7_GPIO15    PC3_GPIO67                        |
|                            | EPI0S37               | x  | x   | x  | x  | PB6_GPIO14    PC2_GPIO66                        |
|                            | EPI0S38               | x  | x   | x  | x  | PF6_GPIO38    PE4_GPIO28                        |
|                            | EPI0S39               | x  | x   | x  | x  | PG2_GPIO42                                      |
|                            | EPI0S40               | x  | x   | x  | x  | PG5_GPIO45                                      |
|                            | EPI0S41               | x  | x   | x  | x  | PG6_GPIO46                                      |

#### 5.10.4.3.1.3 HB-8 FIFO Mode

The HB-8 FIFO Mode uses 8 bits of data, removes ALE and address pins, and optionally adds external FIFO Full/Empty flag inputs. This scheme is used by many devices, such as radios, communication devices (including USB2 devices), and some FPGA configuration (FIFO through block RAM). This FIFO Mode presents the data side of the normal Host-Bus interface, but is paced by FIFO control signals. It is important to consider that the FIFO Full/Empty control inputs may stall the EPI interface and can potentially block other CPU or DMA accesses. For more detailed maps of the HB-8 FIFO Mode, see [Table 5-45](#).

**Table 5-45. EPI MODES – 8-Bit Host-Bus Mode (EPICFG/MODE = 0x2),  
FIFO Mode (EPIHB16CFG/MODE = 0x3)**

| EPI PORT NAME           |                    | EPI SIGNAL FUNCTION                |                                     | DEVICE PIN                                   |            |
|-------------------------|--------------------|------------------------------------|-------------------------------------|--|------------|
| ACCESSIBLE BY Cortex-M3 | ACCESSIBLE BY C28x | WITH ONE CHIP SELECT (CSCFG = 0x1) | WITH TWO CHIP SELECTS (CSCFG = 0x2) | (AVAILABLE GPIOMUX 1 MUXING CHOICES FOR EPI) |            |
| EPI0S0                  |                    | D0                                 | D0                                  | PH3_GPIO51                                   |            |
| EPI0S1                  |                    | D1                                 | D1                                  | PH2_GPIO50                                   |            |
| EPI0S2                  |                    | D2                                 | D2                                  | PC4_GPIO68                                   |            |
| EPI0S3                  |                    | D3                                 | D3                                  | PC5_GPIO69                                   |            |
| EPI0S4                  |                    | D4                                 | D4                                  | PC6_GPIO70                                   |            |
| EPI0S5                  |                    | D5                                 | D5                                  | PC7_GPIO71                                   |            |
| EPI0S6                  |                    | D6                                 | D6                                  | PH0_GPIO48                                   |            |
| EPI0S7                  |                    | D7                                 | D7                                  | PH1_GPIO49                                   |            |
| EPI0S25                 |                    | x                                  | CS1                                 | PE3_GPIO27                                   |            |
| EPI0S30                 |                    | CS0                                | CS0                                 | PD7_GPIO23                                   | PJ6_GPIO62 |
| EPI0S27                 |                    | FFULL                              | FFULL                               | PH7_GPIO55                                   |            |
| EPI0S26                 |                    | FEMPTY                             | FEMPTY                              | PH6_GPIO54                                   |            |
| EPI0S29                 |                    | WR                                 | WR                                  | PD6_GPIO22                                   | PJ5_GPIO61 |
| EPI0S28                 |                    | RD                                 | RD                                  | PD5_GPIO21                                   | PJ4_GPIO60 |
| EPI0S8                  |                    | x                                  | x                                   | PE0_GPIO24                                   |            |
| EPI0S9                  |                    | x                                  | x                                   | PE1_GPIO25                                   |            |
| EPI0S10                 |                    | x                                  | x                                   | PH4_GPIO52                                   |            |
| EPI0S11                 |                    | x                                  | x                                   | PH5_GPIO53                                   |            |
| EPI0S12                 |                    | x                                  | x                                   | PF4_GPIO36                                   |            |
| EPI0S13                 |                    | x                                  | x                                   | PG0_GPIO40                                   |            |
| EPI0S14                 |                    | x                                  | x                                   | PG1_GPIO41                                   |            |
| EPI0S15                 |                    | x                                  | x                                   | PF5_GPIO37                                   |            |
| EPI0S16                 |                    | x                                  | x                                   | PJ0_GPIO56                                   |            |
| EPI0S17                 |                    | x                                  | x                                   | PJ1_GPIO57                                   |            |
| EPI0S18                 |                    | x                                  | x                                   | PJ2_GPIO58                                   |            |
| EPI0S19                 |                    | x                                  | x                                   | PD4_GPIO20                                   | PJ3_GPIO59 |
| EPI0S20                 |                    | x                                  | x                                   | PD2_GPIO18                                   |            |
| EPI0S21                 |                    | x                                  | x                                   | PD3_GPIO19                                   |            |
| EPI0S22                 |                    | x                                  | x                                   | PB5_GPIO13                                   |            |
| EPI0S23                 |                    | x                                  | x                                   | PB4_GPIO12                                   |            |
| EPI0S24                 |                    | x                                  | x                                   | PE2_GPIO26                                   |            |
| EPI0S32                 |                    | x                                  | x                                   | PF2_GPIO34                                   | PC0_GPIO64 |
| EPI0S31                 |                    | x                                  | x                                   | PG7_GPIO47                                   |            |
| EPI0S33                 |                    | x                                  | x                                   | PF3_GPIO35                                   | PC1_GPIO65 |
| EPI0S34                 |                    | x                                  | x                                   | PE4_GPIO28                                   |            |
| EPI0S35                 |                    | x                                  | x                                   | PE5_GPIO29                                   |            |
| EPI0S36                 |                    | x                                  | x                                   | PB7_GPIO15                                   | PC3_GPIO67 |
| EPI0S37                 |                    | x                                  | x                                   | PB6_GPIO14                                   | PC2_GPIO66 |
| EPI0S38                 |                    | x                                  | x                                   | PF6_GPIO38                                   | PE4_GPIO28 |
| EPI0S39                 |                    | x                                  | x                                   | PG2_GPIO42                                   |            |
| EPI0S40                 |                    | x                                  | x                                   | PG5_GPIO45                                   |            |
| EPI0S41                 |                    | x                                  | x                                   | PG6_GPIO46                                   |            |

### 5.10.4.3.2 EPI 16-Bit Host Bus (HB-16) Mode

The 16-Bit Host Bus (HB-16) Mode uses fewer address pins than the 8-Bit Host Bus (HB-8) Mode; hence, more pins are available for data. The HB-16 Mode is also slower than the General-Purpose Mode in order to accommodate older logic. The HB-16 Mode is selected with the MODE field of EPI Configuration Register. Within the HB-16 Mode, two additional registers are used to select address/data muxing, byte selects, chip selects, and other options. These registers are the HB-16 Configuration Register and the HB-16 Configuration2 Register. See Figure 5-21 for a snapshot of HB-16 registers, modes, and features.

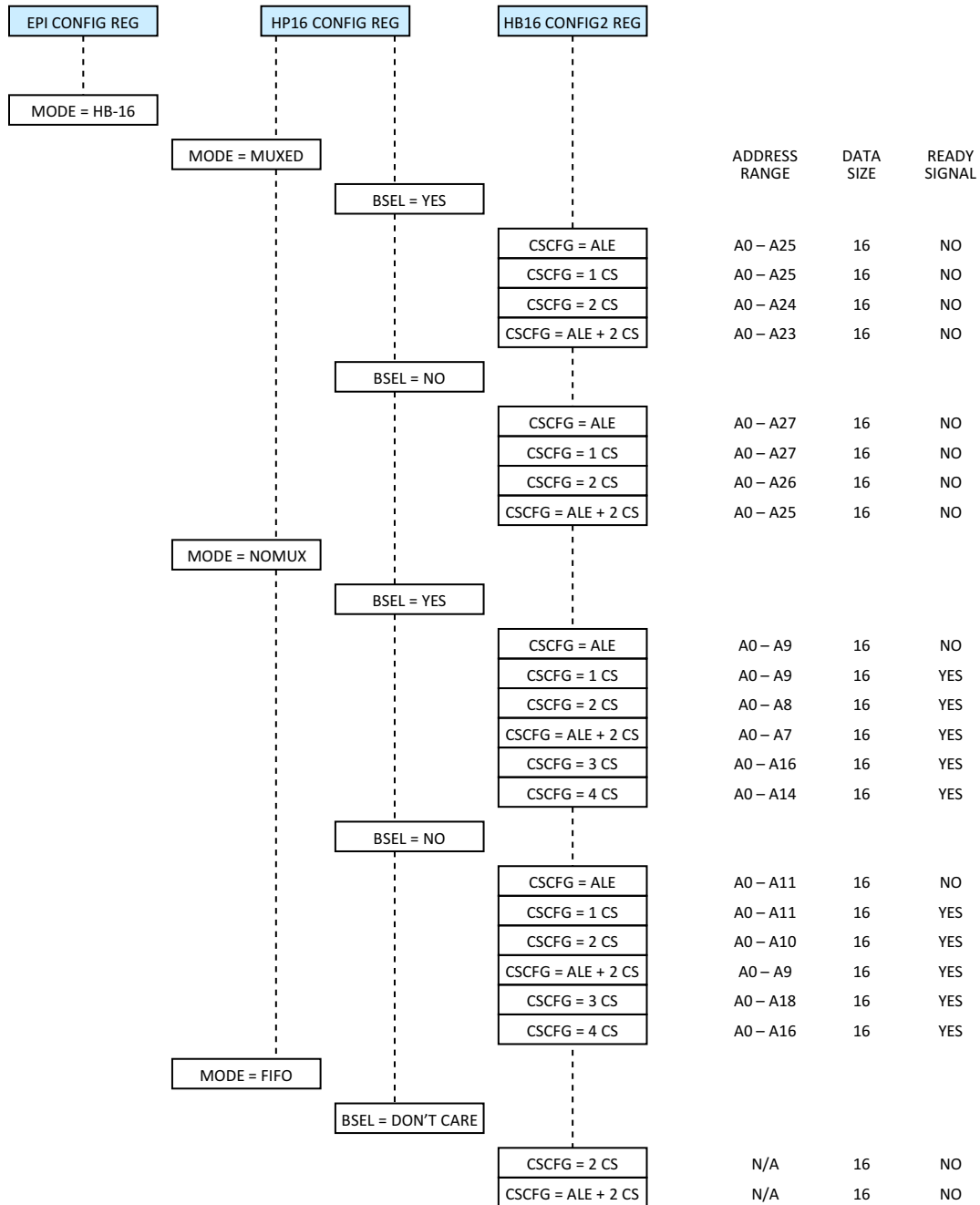

Figure 5-21. EPI 16-Bit Host Bus Mode

### 5.10.4.3.2.1 HB-16 Muxed Address/Data Mode

The HB-16 Muxed Mode multiplexes address signals with low-order data signals. For this reason, the Muxed Mode allows for a larger address space as compared to the Non-Muxed Mode. The HB-16 Muxed Mode is selected with the MODE field of the HB-16 Configuration Register. In addition to data and address signals, the HB-16 Muxed Mode also features the ALE signal (indicating to an external latch to capture address and hold the address until the data phase); RD and WR data strobes; 1–4 CS (Chip Select) signals to enable one of four external peripherals; and two BSEL (Byte Select) signals to accommodate byte accesses to lower or upper half of 16-bit data. The Byte Selects are chosen with the BSEL field of the HB-16 Configuration Register. The ALE and CS options are chosen with the CSCFG field of the HB-16 Configuration2 Register. For more detailed maps of the HB-16 Muxed Mode *without* Byte Selects, see [Table 5-46](#). For more detailed maps of the HB-16 Muxed Mode *with* Byte Selects, see [Table 5-47](#).

**Table 5-46. EPI MODES – 16-Bit Host-Bus Mode (EPICFG/MODE = 0x3), Muxed (EPIHB16CFG/MODE = 0x0), Without Byte Selects (EPIHB16CFG/BSEL = 0x1), and With Chip Selects (EPIHB16CFG2/CSCFG = 0x0,1,2,3)**

| EPI PORT NAME           |                    | EPI SIGNAL FUNCTION                     |                                    |                                     |   | DEVICE PIN                                   |
|-------------------------|--------------------|---|------------------------------------|-------------------------------------|---|--|
| ACCESSIBLE BY Cortex-M3 | ACCESSIBLE BY C28x | WITH ADDRESS LATCH ENABLE (CSCFG = 0x0) | WITH ONE CHIP SELECT (CSCFG = 0x1) | WITH TWO CHIP SELECTS (CSCFG = 0x2) | WITH ALE AND TWO CHIP SELECTS (CSCFG = 0x3) | (AVAILABLE GPIOMUX_1 MUXING CHOICES FOR EPI) |
| EPI0S0                  |                    | AD0                                     | AD0                                | AD0                                 | AD0   | PH3_GPIO51                                   |
| EPI0S1                  |                    | AD1                                     | AD1                                | AD1                                 | AD1   | PH2_GPIO50                                   |
| EPI0S2                  |                    | AD2                                     | AD2                                | AD2                                 | AD2   | PC4_GPIO68                                   |
| EPI0S3                  |                    | AD3                                     | AD3                                | AD3                                 | AD3   | PC5_GPIO69                                   |
| EPI0S4                  |                    | AD4                                     | AD4                                | AD4                                 | AD4   | PC6_GPIO70                                   |
| EPI0S5                  |                    | AD5                                     | AD5                                | AD5                                 | AD5   | PC7_GPIO71                                   |
| EPI0S6                  |                    | AD6                                     | AD6                                | AD6                                 | AD6   | PH0_GPIO48                                   |
| EPI0S7                  |                    | AD7                                     | AD7                                | AD7                                 | AD7   | PH1_GPIO49                                   |
| EPI0S8                  |                    | AD8                                     | AD8                                | AD8                                 | AD8   | PE0_GPIO24                                   |
| EPI0S9                  |                    | AD9                                     | AD9                                | AD9                                 | AD9   | PE1_GPIO25                                   |
| EPI0S10                 |                    | AD10                                    | AD10                               | AD10                                | AD10  | PH4_GPIO52                                   |
| EPI0S11                 |                    | AD11                                    | AD11                               | AD11                                | AD11  | PH5_GPIO53                                   |
| EPI0S12                 |                    | AD12                                    | AD12                               | AD12                                | AD12  | PF4_GPIO36                                   |
| EPI0S13                 |                    | AD13                                    | AD13                               | AD13                                | AD13  | PG0_GPIO40                                   |
| EPI0S14                 |                    | AD14                                    | AD14                               | AD14                                | AD14  | PG1_GPIO41                                   |
| EPI0S15                 |                    | AD15                                    | AD15                               | AD15                                | AD15  | PF5_GPIO37                                   |
|                         |                    |   |                                    |                                     |   |  |
| EPI0S16                 |                    | A16                                     | A16                                | A16                                 | A16   | PJ0_GPIO56                                   |
| EPI0S17                 |                    | A17                                     | A17                                | A17                                 | A17   | PJ1_GPIO57                                   |
| EPI0S18                 |                    | A18                                     | A18                                | A18                                 | A18   | PJ2_GPIO58                                   |
| EPI0S19                 |                    | A19                                     | A19                                | A19                                 | A19   | PD4_GPIO20 PJ3_GPIO59                        |
| EPI0S20                 |                    | A20                                     | A20                                | A20                                 | A20   | PD2_GPIO18                                   |
| EPI0S21                 |                    | A21                                     | A21                                | A21                                 | A21   | PD3_GPIO19                                   |
| EPI0S22                 |                    | A22                                     | A22                                | A22                                 | A22   | PB5_GPIO13                                   |
| EPI0S23                 |                    | A23                                     | A23                                | A23                                 | A23   | PB4_GPIO12                                   |
| EPI0S24                 |                    | A24                                     | A24                                | A24                                 | A24   | PE2_GPIO26                                   |
| EPI0S25                 |                    | A25                                     | A25                                | A25                                 | A25   | PE3_GPIO27                                   |
| EPI0S26                 |                    | A26                                     | A26                                | A26                                 | $\overline{CS0}$                            | PH6_GPIO54                                   |
| EPI0S27                 |                    | A27                                     | A27                                | $\overline{CS1}$                    | $\overline{CS1}$                            | PH7_GPIO55                                   |
| EPI0S30                 |                    | ALE                                     | $\overline{CS0}$                   | $\overline{CS0}$                    | ALE   | PD7_GPIO23 PJ6_GPIO62                        |
|                         |                    |   |                                    |                                     |   |  |
| EPI0S29                 |                    | WR                                      | WR                                 | WR                                  | WR  | PD6_GPIO22 PJ5_GPIO61                        |
| EPI0S28                 |                    | RD                                      | RD                                 | RD                                  | RD  | PD5_GPIO21 PJ4_GPIO60                        |

**Table 5-46. EPI MODES – 16-Bit Host-Bus Mode (EPICFG/MODE = 0x3),  
Muxed (EPIHB16CFG/MODE = 0x0), Without Byte Selects (EPIHB16CFG/BSEL = 0x1),  
and With Chip Selects (EPIHB16CFG2/CSCFG = 0x0,1,2,3) (continued)**

| EPI PORT NAME           |                    | EPI SIGNAL FUNCTION                     |                                    |                                     |   | DEVICE PIN                                   |            |
|-------------------------|--------------------|---|------------------------------------|-------------------------------------|---|--|------------|
| ACCESSIBLE BY Cortex-M3 | ACCESSIBLE BY C28x | WITH ADDRESS LATCH ENABLE (CSCFG = 0x0) | WITH ONE CHIP SELECT (CSCFG = 0x1) | WITH TWO CHIP SELECTS (CSCFG = 0x2) | WITH ALE AND TWO CHIP SELECTS (CSCFG = 0x3) | (AVAILABLE GPIOMUX_1 MUXING CHOICES FOR EPI) |            |
|                         | EPI0S31            | x                                       | x                                  | x                                   | x   | PG7_GPIO47                                   |            |
|                         | EPI0S32            | x                                       | x                                  | x                                   | x   | PF2_GPIO34                                   | PC0_GPIO64 |
|                         | EPI0S33            | x                                       | x                                  | x                                   | x   | PF3_GPIO35                                   | PC1_GPIO65 |
|                         | EPI0S34            | x                                       | x                                  | x                                   | x   | PE4_GPIO28                                   |            |
|                         | EPI0S35            | x                                       | x                                  | x                                   | x   | PE5_GPIO29                                   |            |
|                         | EPI0S36            | x                                       | x                                  | x                                   | x   | PB7_GPIO15                                   | PC3_GPIO67 |
|                         | EPI0S37            | x                                       | x                                  | x                                   | x   | PB6_GPIO14                                   | PC2_GPIO66 |
|                         | EPI0S38            | x                                       | x                                  | x                                   | x   | PF6_GPIO38                                   | PE4_GPIO28 |
|                         | EPI0S39            | x                                       | x                                  | x                                   | x   | PG2_GPIO42                                   |            |
|                         | EPI0S40            | x                                       | x                                  | x                                   | x   | PG5_GPIO45                                   |            |
|                         | EPI0S41            | x                                       | x                                  | x                                   | x   | PG6_GPIO46                                   |            |

**Table 5-47. EPI MODES – 16-Bit Host-Bus (EPICFG/MODE = 0x3),  
Muxed (EPIHB16CFG/MODE = 0x0), With Byte Selects (EPIHB16CFG/BSEL = 0x0),  
and With Chip Selects (EPIHB16CFG2/CSCFG=0x0,1,2,3)**

| EPI PORT NAME           |                    | EPI SIGNAL FUNCTION                     |                                    |                                     |   | DEVICE PIN                                   |            |
|-------------------------|--------------------|---|------------------------------------|-------------------------------------|---|--|------------|
| ACCESSIBLE BY Cortex-M3 | ACCESSIBLE BY C28x | WITH ADDRESS LATCH ENABLE (CSCFG = 0x0) | WITH ONE CHIP SELECT (CSCFG = 0x1) | WITH TWO CHIP SELECTS (CSCFG = 0x2) | WITH ALE AND TWO CHIP SELECTS (CSCFG = 0x3) | (AVAILABLE GPIOMUX_1 MUXING CHOICES FOR EPI) |            |
|                         | EPI0S0             | AD0                                     | AD0                                | AD0                                 | AD0   | PH3_GPIO51                                   |            |
|                         | EPI0S1             | AD1                                     | AD1                                | AD1                                 | AD1   | PH2_GPIO50                                   |            |
|                         | EPI0S2             | AD2                                     | AD2                                | AD2                                 | AD2   | PC4_GPIO68                                   |            |
|                         | EPI0S3             | AD3                                     | AD3                                | AD3                                 | AD3   | PC5_GPIO69                                   |            |
|                         | EPI0S4             | AD4                                     | AD4                                | AD4                                 | AD4   | PC6_GPIO70                                   |            |
|                         | EPI0S5             | AD5                                     | AD5                                | AD5                                 | AD5   | PC7_GPIO71                                   |            |
|                         | EPI0S6             | AD6                                     | AD6                                | AD6                                 | AD6   | PH0_GPIO48                                   |            |
|                         | EPI0S7             | AD7                                     | AD7                                | AD7                                 | AD7   | PH1_GPIO49                                   |            |
|                         | EPI0S8             | AD8                                     | AD8                                | AD8                                 | AD8   | PE0_GPIO24                                   |            |
|                         | EPI0S9             | AD9                                     | AD9                                | AD9                                 | AD9   | PE1_GPIO25                                   |            |
|                         | EPI0S10            | AD10                                    | AD10                               | AD10                                | AD10  | PH4_GPIO52                                   |            |
|                         | EPI0S11            | AD11                                    | AD11                               | AD11                                | AD11  | PH5_GPIO53                                   |            |
|                         | EPI0S12            | AD12                                    | AD12                               | AD12                                | AD12  | PF4_GPIO36                                   |            |
|                         | EPI0S13            | AD13                                    | AD13                               | AD13                                | AD13  | PG0_GPIO40                                   |            |
|                         | EPI0S14            | AD14                                    | AD14                               | AD14                                | AD14  | PG1_GPIO41                                   |            |
|                         | EPI0S15            | AD15                                    | AD15                               | AD15                                | AD15  | PF5_GPIO37                                   |            |
|                         | EPI0S16            | A16                                     | A16                                | A16                                 | A16   | PJ0_GPIO56                                   |            |
|                         | EPI0S17            | A17                                     | A17                                | A17                                 | A17   | PJ1_GPIO57                                   |            |
|                         | EPI0S18            | A18                                     | A18                                | A18                                 | A18   | PJ2_GPIO58                                   |            |
|                         | EPI0S19            | A19                                     | A19                                | A19                                 | A19   | PD4_GPIO20                                   | PJ3_GPIO59 |
|                         | EPI0S20            | A20                                     | A20                                | A20                                 | A20   | PD2_GPIO18                                   |            |
|                         | EPI0S21            | A21                                     | A21                                | A21                                 | A21   | PD3_GPIO19                                   |            |
|                         | EPI0S22            | A22                                     | A22                                | A22                                 | A22   | PB5_GPIO13                                   |            |
|                         | EPI0S23            | A23                                     | A23                                | A23                                 | A23   | PB4_GPIO12                                   |            |
|                         | EPI0S24            | A24                                     | A24                                | A24                                 | BSEL0                                       | PE2_GPIO26                                   |            |

**Table 5-47. EPI MODES – 16-Bit Host-Bus (EPICFG/MODE = 0x3), Muxed (EPIHB16CFG/MODE = 0x0), With Byte Selects (EPIHB16CFG/BSEL = 0x0), and With Chip Selects (EPIHB16CFG2/CSCFG=0x0,1,2,3) (continued)**

| EPI PORT NAME           |                    | EPI SIGNAL FUNCTION                     |                                    |                                     |   | DEVICE PIN                                   |            |
|-------------------------|--------------------|---|------------------------------------|-------------------------------------|---|--|------------|
| ACCESSIBLE BY Cortex-M3 | ACCESSIBLE BY C28x | WITH ADDRESS LATCH ENABLE (CSCFG = 0x0) | WITH ONE CHIP SELECT (CSCFG = 0x1) | WITH TWO CHIP SELECTS (CSCFG = 0x2) | WITH ALE AND TWO CHIP SELECTS (CSCFG = 0x3) | (AVAILABLE GPIOMUX_1 MUXING CHOICES FOR EPI) |            |
| EPI0S25                 |                    | A25                                     | A25                                | $\overline{\text{BSEL0}}$           | $\overline{\text{BSEL1}}$                   | PE3_GPIO27                                   |            |
| EPI0S26                 |                    | $\overline{\text{BSEL0}}$               | $\overline{\text{BSEL0}}$          | $\overline{\text{BSEL1}}$           | $\overline{\text{CS0}}$                     | PH6_GPIO54                                   |            |
| EPI0S27                 |                    | $\overline{\text{BSEL1}}$               | $\overline{\text{BSEL1}}$          | $\overline{\text{CS1}}$             | $\overline{\text{CS1}}$                     | PH7_GPIO55                                   |            |
| EPI0S30                 |                    | ALE                                     | $\overline{\text{CS0}}$            | $\overline{\text{CS0}}$             | ALE   | PD7_GPIO23                                   | PJ6_GPIO62 |
| EPI0S29                 |                    | WR                                      | WR                                 | WR                                  | WR  | PD6_GPIO22                                   | PJ5_GPIO61 |
| EPI0S28                 |                    | RD                                      | RD                                 | RD                                  | RD  | PD5_GPIO21                                   | PJ4_GPIO60 |
| EPI0S31                 |                    | x                                       | x                                  | x                                   | x   | PG7_GPIO47                                   |            |
| EPI0S32                 |                    | x                                       | x                                  | x                                   | x   | PF2_GPIO34                                   | PC0_GPIO64 |
| EPI0S33                 |                    | x                                       | x                                  | x                                   | x   | PF3_GPIO35                                   | PC1_GPIO65 |
| EPI0S34                 |                    | x                                       | x                                  | x                                   | x   | PE4_GPIO28                                   |            |
| EPI0S35                 |                    | x                                       | x                                  | x                                   | x   | PE5_GPIO29                                   |            |
| EPI0S36                 |                    | x                                       | x                                  | x                                   | x   | PB7_GPIO15                                   | PC3_GPIO67 |
| EPI0S37                 |                    | x                                       | x                                  | x                                   | x   | PB6_GPIO14                                   | PC2_GPIO66 |
| EPI0S38                 |                    | x                                       | x                                  | x                                   | x   | PF6_GPIO38                                   | PE4_GPIO28 |
| EPI0S39                 |                    | x                                       | x                                  | x                                   | x   | PG2_GPIO42                                   |            |
| EPI0S40                 |                    | x                                       | x                                  | x                                   | x   | PG5_GPIO45                                   |            |
| EPI0S41                 |                    | x                                       | x                                  | x                                   | x   | PG6_GPIO46                                   |            |

**5.10.4.3.2.2 HB-16 Non-Muxed Address/Data Mode**

The HB-16 Non-Muxed Mode uses dedicated pins for address and data signals. For this reason, the Non-Muxed Mode has reduced address reach as compared to the Muxed Mode. The HB-16 Non-Muxed Mode is selected with the MODE field of the HB-16 Configuration Register. In addition to data and address signals, the HB-16 Non-Muxed Mode also features the ALE signal (indicating to an external latch to capture address and hold the address until the data phase); RD and WR data strobes; 1–4 CS (Chip Select) signals to enable one of four external peripherals; and two BSEL (Byte Select) signals to accommodate byte accesses to lower or upper half of 16-bit data. The Byte Selects are chosen with the BSEL field of the HB-16 Configuration Register. The ALE and CS options are chosen with the CSCFG field of the HB-16 Configuration2 Register. For Non-Muxed bus cycles, most of the CSCFG modes also support a RDY signal. The RDY input to EPI is used by an external peripheral to extend bus cycles when the peripheral needs more time to complete reading or writing of data. While most EPI modes use up to 32 pins, the Non-Muxed CSCFG modes with 3 and 4 Chip Selects use 10 additional pins to extend the address reach and the number of CS signals. For detailed maps of HB-16 Non-Muxed Modes *without* Byte Selects, see [Table 5-48](#) and [Table 5-49](#). For detailed maps of HB-16 Non-Muxed Modes *with* Byte Selects, see [Table 5-50](#) and [Table 5-51](#).

**Table 5-48. EPI MODES – 16-Bit Host-Bus Mode (EPICFG/MODE = 0x3),  
Non-Muxed (EPIHB16CFG/MODE = 0x1), Without Byte Selects (EPIHB16CFG/BSEL = 0x1),  
and With Chip Selects (EPIHB16CFG2/CSCFG = 0x0,1,2,3)**

| EPI PORT NAME              |                       | EPI SIGNAL FUNCTION                              |   |  |  | DEVICE PIN                                      |
|----------------------------|-----------------------|--|---|--|--|---|
| ACCESSIBLE BY<br>Cortex-M3 | ACCESSIBLE BY<br>C28x | WITH<br>ADDRESS LATCH<br>ENABLE<br>(CSCFG = 0x0) | WITH<br>ONE<br>CHIP SELECT<br>(CSCFG = 0x1) | WITH<br>TWO<br>CHIP SELECTS<br>(CSCFG = 0x2) | WITH<br>ALE AND TWO<br>CHIP SELECTS<br>(CSCFG = 0x3) | (AVAILABLE GPIOMUX_1<br>MUXING CHOICES FOR EPI) |
|                            | EPI0S0                | D0   | D0  | D0   | D0   | PH3_GPIO51                                      |
|                            | EPI0S1                | D1   | D1  | D1   | D1   | PH2_GPIO50                                      |
|                            | EPI0S2                | D2   | D2  | D2   | D2   | PC4_GPIO68                                      |
|                            | EPI0S3                | D3   | D3  | D3   | D3   | PC5_GPIO69                                      |
|                            | EPI0S4                | D4   | D4  | D4   | D4   | PC6_GPIO70                                      |
|                            | EPI0S5                | D5   | D5  | D5   | D5   | PC7_GPIO71                                      |
|                            | EPI0S6                | D6   | D6  | D6   | D6   | PH0_GPIO48                                      |
|                            | EPI0S7                | D7   | D7  | D7   | D7   | PH1_GPIO49                                      |
|                            | EPI0S8                | D8   | D8  | D8   | D8   | PE0_GPIO24                                      |
|                            | EPI0S9                | D9   | D9  | D9   | D9   | PE1_GPIO25                                      |
|                            | EPI0S10               | D10  | D10   | D10  | D10  | PH4_GPIO52                                      |
|                            | EPI0S11               | D11  | D11   | D11  | D11  | PH5_GPIO53                                      |
|                            | EPI0S12               | D12  | D12   | D12  | D12  | PF4_GPIO36                                      |
|                            | EPI0S13               | D13  | D13   | D13  | D13  | PG0_GPIO40                                      |
|                            | EPI0S14               | D14  | D14   | D14  | D14  | PG1_GPIO41                                      |
|                            | EPI0S15               | D15  | D15   | D15  | D15  | PF5_GPIO37                                      |
|                            | EPI0S16               | A0   | A0  | A0   | A0   | PJ0_GPIO56                                      |
|                            | EPI0S17               | A1   | A1  | A1   | A1   | PJ1_GPIO57                                      |
|                            | EPI0S18               | A2   | A2  | A2   | A2   | PJ2_GPIO58                                      |
|                            | EPI0S19               | A3   | A3  | A3   | A3   | PD4_GPIO20 PJ3_GPIO59                           |
|                            | EPI0S20               | A4   | A4  | A4   | A4   | PD2_GPIO18                                      |
|                            | EPI0S21               | A5   | A5  | A5   | A5   | PD3_GPIO19                                      |
|                            | EPI0S22               | A6   | A6  | A6   | A6   | PB5_GPIO13                                      |
|                            | EPI0S23               | A7   | A7  | A7   | A7   | PB4_GPIO12                                      |
|                            | EPI0S24               | A8   | A8  | A8   | A8   | PE2_GPIO26                                      |
|                            | EPI0S25               | A9   | A9  | A9   | A9   | PE3_GPIO27                                      |
|                            | EPI0S26               | A10  | A10   | A10  | $\overline{CS0}$                                     | PH6_GPIO54                                      |
|                            | EPI0S27               | A11  | A11   | $\overline{CS1}$                             | $\overline{CS1}$                                     | PH7_GPIO55                                      |
|                            | EPI0S30               | ALE  | $\overline{CS0}$                            | $\overline{CS0}$                             | ALE  | PD7_GPIO23 PJ6_GPIO62                           |
|                            | EPI0S29               | WR   | WR  | WR   | WR   | PD6_GPIO22 PJ5_GPIO61                           |
|                            | EPI0S28               | RD   | RD  | RD   | RD   | PD5_GPIO21 PJ4_GPIO60                           |
|                            | EPI0S32               | x  | RDY   | RDY  | RDY  | PF2_GPIO34 PC0_GPIO64                           |
|                            | EPI0S31               | x  | x   | x  | x  | PG7_GPIO47                                      |
|                            | EPI0S33               | x  | x   | x  | x  | PF3_GPIO35 PC1_GPIO65                           |
|                            | EPI0S34               | x  | x   | x  | x  | PE4_GPIO28                                      |
|                            | EPI0S35               | x  | x   | x  | x  | PE5_GPIO29                                      |
|                            | EPI0S36               | x  | x   | x  | x  | PB7_GPIO15 PC3_GPIO67                           |
|                            | EPI0S37               | x  | x   | x  | x  | PB6_GPIO14 PC2_GPIO66                           |
|                            | EPI0S38               | x  | x   | x  | x  | PF6_GPIO38 PE4_GPIO28                           |
|                            | EPI0S39               | x  | x   | x  | x  | PG2_GPIO42                                      |
|                            | EPI0S40               | x  | x   | x  | x  | PG5_GPIO45                                      |
|                            | EPI0S41               | x  | x   | x  | x  | PG6_GPIO46                                      |

**Table 5-49. EPI MODES – 16-Bit Host-Bus Mode (EPICFG/MODE=0x3), Non-Muxed (EPIHB16CFG/MODE = 0x1), Without Byte Selects (EPIHB16CFG/BSEL = 0x1), and With Additional Chip Selects (EPIHB16CFG2/CSCFG = 0x5,7)**

| EPI PORT NAME           |                    | EPI SIGNAL FUNCTION                   | DEVICE PIN                                   |            | EPI PORT NAME           |                    | EPI SIGNAL FUNCTION                  | DEVICE PIN                                   |            |
|-------------------------|--------------------|---------------------------------------|--|------------|-------------------------|--------------------|--------------------------------------|--|------------|
| ACCESSIBLE BY Cortex-M3 | ACCESSIBLE BY C28x | WITH THREE CHIP SELECTS (CSCFG = 0x7) | (AVAILABLE GPIOMUX_1 MUXING CHOICES FOR EPI) |            | ACCESSIBLE BY Cortex-M3 | ACCESSIBLE BY C28x | WITH FOUR CHIP SELECTS (CSCFG = 0x5) | (AVAILABLE GPIOMUX_1 MUXING CHOICES FOR EPI) |            |
| EPI0S0                  |                    | D0                                    | PH3_GPIO51                                   |            | EPI0S0                  |                    | D0                                   | PH3_GPIO51                                   |            |
| EPI0S1                  |                    | D1                                    | PH2_GPIO50                                   |            | EPI0S1                  |                    | D1                                   | PH2_GPIO50                                   |            |
| EPI0S2                  |                    | D2                                    | PC4_GPIO68                                   |            | EPI0S2                  |                    | D2                                   | PC4_GPIO68                                   |            |
| EPI0S3                  |                    | D3                                    | PC5_GPIO69                                   |            | EPI0S3                  |                    | D3                                   | PC5_GPIO69                                   |            |
| EPI0S4                  |                    | D4                                    | PC6_GPIO70                                   |            | EPI0S4                  |                    | D4                                   | PC6_GPIO70                                   |            |
| EPI0S5                  |                    | D5                                    | PC7_GPIO71                                   |            | EPI0S5                  |                    | D5                                   | PC7_GPIO71                                   |            |
| EPI0S6                  |                    | D6                                    | PH0_GPIO48                                   |            | EPI0S6                  |                    | D6                                   | PH0_GPIO48                                   |            |
| EPI0S7                  |                    | D7                                    | PH1_GPIO49                                   |            | EPI0S7                  |                    | D7                                   | PH1_GPIO49                                   |            |
| EPI0S8                  |                    | D8                                    | PE0_GPIO24                                   |            | EPI0S8                  |                    | D8                                   | PE0_GPIO24                                   |            |
| EPI0S9                  |                    | D9                                    | PE1_GPIO25                                   |            | EPI0S9                  |                    | D9                                   | PE1_GPIO25                                   |            |
| EPI0S10                 |                    | D10                                   | PH4_GPIO52                                   |            | EPI0S10                 |                    | D10                                  | PH4_GPIO52                                   |            |
| EPI0S11                 |                    | D11                                   | PH5_GPIO53                                   |            | EPI0S11                 |                    | D11                                  | PH5_GPIO53                                   |            |
| EPI0S12                 |                    | D12                                   | PF4_GPIO36                                   |            | EPI0S12                 |                    | D12                                  | PF4_GPIO36                                   |            |
| EPI0S13                 |                    | D13                                   | PG0_GPIO40                                   |            | EPI0S13                 |                    | D13                                  | PG0_GPIO40                                   |            |
| EPI0S14                 |                    | D14                                   | PG1_GPIO41                                   |            | EPI0S14                 |                    | D14                                  | PG1_GPIO41                                   |            |
| EPI0S15                 |                    | D15                                   | PF5_GPIO37                                   |            | EPI0S15                 |                    | D15                                  | PF5_GPIO37                                   |            |
| EPI0S16                 |                    | A0                                    | PJ0_GPIO56                                   |            | EPI0S16                 |                    | A0                                   | PJ0_GPIO56                                   |            |
| EPI0S17                 |                    | A1                                    | PJ1_GPIO57                                   |            | EPI0S17                 |                    | A1                                   | PJ1_GPIO57                                   |            |
| EPI0S18                 |                    | A2                                    | PJ2_GPIO58                                   |            | EPI0S18                 |                    | A2                                   | PJ2_GPIO58                                   |            |
| EPI0S19                 |                    | A3                                    | PD4_GPIO20                                   | PJ3_GPIO59 | EPI0S19                 |                    | A3                                   | PD4_GPIO20                                   | PJ3_GPIO59 |
| EPI0S20                 |                    | A4                                    | PD2_GPIO18                                   |            | EPI0S20                 |                    | A4                                   | PD2_GPIO18                                   |            |
| EPI0S21                 |                    | A5                                    | PD3_GPIO19                                   |            | EPI0S21                 |                    | A5                                   | PD3_GPIO19                                   |            |
| EPI0S22                 |                    | A6                                    | PB5_GPIO13                                   |            | EPI0S22                 |                    | A6                                   | PB5_GPIO13                                   |            |
| EPI0S23                 |                    | A7                                    | PB4_GPIO12                                   |            | EPI0S23                 |                    | A7                                   | PB4_GPIO12                                   |            |
| EPI0S24                 |                    | A8                                    | PE2_GPIO26                                   |            | EPI0S24                 |                    | A8                                   | PE2_GPIO26                                   |            |
| EPI0S25                 |                    | A9                                    | PE3_GPIO27                                   |            | EPI0S25                 |                    | A9                                   | PE3_GPIO27                                   |            |
| EPI0S26                 |                    | A10                                   | PH6_GPIO54                                   |            | EPI0S26                 |                    | A10                                  | PH6_GPIO54                                   |            |
| EPI0S36                 |                    | A11                                   | PB7_GPIO15                                   | PC3_GPIO67 | EPI0S36                 |                    | A11                                  | PB7_GPIO15                                   | PC3_GPIO67 |
| EPI0S37                 |                    | A12                                   | PB6_GPIO14                                   | PC2_GPIO66 | EPI0S37                 |                    | A12                                  | PB6_GPIO14                                   | PC2_GPIO66 |
| EPI0S38                 |                    | A13                                   | PF6_GPIO38                                   | PE4_GPIO28 | EPI0S38                 |                    | A13                                  | PF6_GPIO38                                   | PE4_GPIO28 |
| EPI0S39                 |                    | A14                                   | PG2_GPIO42                                   |            | EPI0S39                 |                    | A14                                  | PG2_GPIO42                                   |            |
| EPI0S27                 |                    | A15                                   | PH7_GPIO55                                   |            | EPI0S40                 |                    | A15                                  | PG5_GPIO45                                   |            |
| EPI0S35                 |                    | A16                                   | PE5_GPIO29                                   |            | EPI0S41                 |                    | A16                                  | PG6_GPIO46                                   |            |
| EPI0S40                 |                    | A17                                   | PG5_GPIO45                                   |            | EPI0S30                 | $\overline{CS0}$   | PD7_GPIO23                           |  | PJ6_GPIO62 |
| EPI0S41                 |                    | A18                                   | PG6_GPIO46                                   |            | EPI0S27                 | $\overline{CS1}$   | PH7_GPIO55                           |  |            |
| EPI0S30                 | $\overline{CS0}$   | PD7_GPIO23                            |  | PJ6_GPIO62 | EPI0S34                 | $\overline{CS2}$   | PE4_GPIO28                           |  |            |
| EPI0S34                 | $\overline{CS2}$   | PE4_GPIO28                            |  |            | EPI0S33                 | $\overline{CS3}$   | PF3_GPIO35                           |  | PC1_GPIO65 |
| EPI0S33                 | $\overline{CS3}$   | PF3_GPIO35                            |  | PC1_GPIO65 |                         |                    |                                      |  |            |
| EPI0S29                 |                    | WR                                    | PD6_GPIO22                                   | PJ5_GPIO61 | EPI0S29                 | WR                 | PD6_GPIO22                           | PJ5_GPIO61                                   |            |
| EPI0S28                 |                    | RD                                    | PD5_GPIO21                                   | PJ4_GPIO60 | EPI0S28                 | RD                 | PD5_GPIO21                           | PJ4_GPIO60                                   |            |
| EPI0S32                 |                    | RDY                                   | PF2_GPIO34                                   | PC0_GPIO64 | EPI0S32                 | RDY                | PF2_GPIO34                           | PC0_GPIO64                                   |            |
| EPI0S31                 |                    | x                                     | PG7_GPIO47                                   |            | EPI0S31                 | x                  | PG7_GPIO47                           |  |            |
|                         |                    |                                       |  |            | EPI0S35                 | x                  | PE5_GPIO29                           |  |            |

**Table 5-50. EPI MODES – 16-Bit Host-Bus (EPICFG/MODE = 0x3),  
Non-Muxed (EPIHB16CFG/MODE = 0x1), With Byte Selects (EPIHB16CFG/BSEL = 0x0),  
and With Chip Selects (EPIHB16CFG2/CSCFG = 0x0,1,2,3)**

| EPI PORT NAME              |                       | EPI SIGNAL FUNCTION                              |   |  |  | DEVICE PIN                                      |
|----------------------------|-----------------------|--|---|--|--|---|
| ACCESSIBLE BY<br>Cortex-M3 | ACCESSIBLE BY<br>C28x | WITH<br>ADDRESS LATCH<br>ENABLE<br>(CSCFG = 0x0) | WITH<br>ONE<br>CHIP SELECT<br>(CSCFG = 0x1) | WITH<br>TWO<br>CHIP SELECTS<br>(CSCFG = 0x2) | WITH<br>ALE AND TWO<br>CHIP SELECTS<br>(CSCFG = 0x3) | (AVAILABLE GPIOMUX_1<br>MUXING CHOICES FOR EPI) |
|                            | EPI0S0                | D0   | D0  | D0   | D0   | PH3_GPIO51                                      |
|                            | EPI0S1                | D1   | D1  | D1   | D1   | PH2_GPIO50                                      |
|                            | EPI0S2                | D2   | D2  | D2   | D2   | PC4_GPIO68                                      |
|                            | EPI0S3                | D3   | D3  | D3   | D3   | PC5_GPIO69                                      |
|                            | EPI0S4                | D4   | D4  | D4   | D4   | PC6_GPIO70                                      |
|                            | EPI0S5                | D5   | D5  | D5   | D5   | PC7_GPIO71                                      |
|                            | EPI0S6                | D6   | D6  | D6   | D6   | PH0_GPIO48                                      |
|                            | EPI0S7                | D7   | D7  | D7   | D7   | PH1_GPIO49                                      |
|                            | EPI0S8                | D8   | D8  | D8   | D8   | PE0_GPIO24                                      |
|                            | EPI0S9                | D9   | D9  | D9   | D9   | PE1_GPIO25                                      |
|                            | EPI0S10               | D10  | D10   | D10  | D10  | PH4_GPIO52                                      |
|                            | EPI0S11               | D11  | D11   | D11  | D11  | PH5_GPIO53                                      |
|                            | EPI0S12               | D12  | D12   | D12  | D12  | PF4_GPIO36                                      |
|                            | EPI0S13               | D13  | D13   | D13  | D13  | PG0_GPIO40                                      |
|                            | EPI0S14               | D14  | D14   | D14  | D14  | PG1_GPIO41                                      |
|                            | EPI0S15               | D15  | D15   | D15  | D15  | PF5_GPIO37                                      |
|                            |                       |  |   |  |  |   |
|                            | EPI0S16               | A0   | A0  | A0   | A0   | PJ0_GPIO56                                      |
|                            | EPI0S17               | A1   | A1  | A1   | A1   | PJ1_GPIO57                                      |
|                            | EPI0S18               | A2   | A2  | A2   | A2   | PJ2_GPIO58                                      |
|                            | EPI0S19               | A3   | A3  | A3   | A3   | PD4_GPIO20 PJ3_GPIO59                           |
|                            | EPI0S20               | A4   | A4  | A4   | A4   | PD2_GPIO18                                      |
|                            | EPI0S21               | A5   | A5  | A5   | A5   | PD3_GPIO19                                      |
|                            | EPI0S22               | A6   | A6  | A6   | A6   | PB5_GPIO13                                      |
|                            | EPI0S23               | A7   | A7  | A7   | A7   | PB4_GPIO12                                      |
|                            | EPI0S24               | A8   | A8  | A8   | BSEL0  | PE2_GPIO26                                      |
|                            | EPI0S25               | A9   | A9  | BSEL0  | BSEL1  | PE3_GPIO27                                      |
|                            | EPI0S26               | BSEL0  | BSEL0                                       | BSEL1  | CS0  | PH6_GPIO54                                      |
|                            | EPI0S27               | BSEL1  | BSEL1                                       | CS1  | CS1  | PH7_GPIO55                                      |
|                            | EPI0S30               | ALE  | CS0   | CS0  | ALE  | PD7_GPIO23 PJ6_GPIO62                           |
|                            |                       |  |   |  |  |   |
|                            | EPI0S29               | WR   | WR  | WR   | WR   | PD6_GPIO22 PJ5_GPIO61                           |
|                            | EPI0S28               | RD   | RD  | RD   | RD   | PD5_GPIO21 PJ4_GPIO60                           |
|                            | EPI0S32               | x  | RDY   | RDY  | RDY  | PF2_GPIO34 PC0_GPIO64                           |
|                            |                       |  |   |  |  |   |
|                            | EPI0S31               | x  | x   | x  | x  | PG7_GPIO47                                      |
|                            | EPI0S33               | x  | x   | x  | x  | PF3_GPIO35 PC1_GPIO65                           |
|                            | EPI0S34               | x  | x   | x  | x  | PE4_GPIO28                                      |
|                            | EPI0S35               | x  | x   | x  | x  | PE5_GPIO29                                      |
|                            | EPI0S36               | x  | x   | x  | x  | PB7_GPIO15 PC3_GPIO67                           |
|                            | EPI0S37               | x  | x   | x  | x  | PB6_GPIO14 PC2_GPIO66                           |
|                            | EPI0S38               | x  | x   | x  | x  | PF6_GPIO38 PE4_GPIO28                           |
|                            | EPI0S39               | x  | x   | x  | x  | PG2_GPIO42                                      |
|                            | EPI0S40               | x  | x   | x  | x  | PG5_GPIO45                                      |
|                            | EPI0S41               | x  | x   | x  | x  | PG6_GPIO46                                      |

**Table 5-51. EPI MODES – 16-Bit Host-Bus (EPICFG/MODE = 0x3),  
Non-Muxed (EPIHB16CFG/MODE = 0x1), With Byte Selects (EPIHB16CFG/BSEL = 0x0),  
and With Additional Chip Selects (EPIHB16CFG2/CSCFG = 0x5,7)**

| EPI PORT NAME           |                    | EPI SIGNAL FUNCTION                   | DEVICE PIN                                   |            | EPI PORT NAME           |                    | EPI SIGNAL FUNCTION                  | DEVICE PIN                                   |            |
|-------------------------|--------------------|---------------------------------------|--|------------|-------------------------|--------------------|--------------------------------------|--|------------|
| ACCESSIBLE BY Cortex-M3 | ACCESSIBLE BY C28x | WITH THREE CHIP SELECTS (CSCFG = 0x7) | (AVAILABLE GPIOMUX_1 MUXING CHOICES FOR EPI) |            | ACCESSIBLE BY Cortex-M3 | ACCESSIBLE BY C28x | WITH FOUR CHIP SELECTS (CSCFG = 0x5) | (AVAILABLE GPIOMUX_1 MUXING CHOICES FOR EPI) |            |
| EPI0S0                  |                    | D0                                    | PH3_GPIO51                                   |            | EPI0S0                  |                    | D0                                   | PH3_GPIO51                                   |            |
| EPI0S1                  |                    | D1                                    | PH2_GPIO50                                   |            | EPI0S1                  |                    | D1                                   | PH2_GPIO50                                   |            |
| EPI0S2                  |                    | D2                                    | PC4_GPIO68                                   |            | EPI0S2                  |                    | D2                                   | PC4_GPIO68                                   |            |
| EPI0S3                  |                    | D3                                    | PC5_GPIO69                                   |            | EPI0S3                  |                    | D3                                   | PC5_GPIO69                                   |            |
| EPI0S4                  |                    | D4                                    | PC6_GPIO70                                   |            | EPI0S4                  |                    | D4                                   | PC6_GPIO70                                   |            |
| EPI0S5                  |                    | D5                                    | PC7_GPIO71                                   |            | EPI0S5                  |                    | D5                                   | PC7_GPIO71                                   |            |
| EPI0S6                  |                    | D6                                    | PH0_GPIO48                                   |            | EPI0S6                  |                    | D6                                   | PH0_GPIO48                                   |            |
| EPI0S7                  |                    | D7                                    | PH1_GPIO49                                   |            | EPI0S7                  |                    | D7                                   | PH1_GPIO49                                   |            |
| EPI0S8                  |                    | D8                                    | PE0_GPIO24                                   |            | EPI0S8                  |                    | D8                                   | PE0_GPIO24                                   |            |
| EPI0S9                  |                    | D9                                    | PE1_GPIO25                                   |            | EPI0S9                  |                    | D9                                   | PE1_GPIO25                                   |            |
| EPI0S10                 |                    | D10                                   | PH4_GPIO52                                   |            | EPI0S10                 |                    | D10                                  | PH4_GPIO52                                   |            |
| EPI0S11                 |                    | D11                                   | PH5_GPIO53                                   |            | EPI0S11                 |                    | D11                                  | PH5_GPIO53                                   |            |
| EPI0S12                 |                    | D12                                   | PF4_GPIO36                                   |            | EPI0S12                 |                    | D12                                  | PF4_GPIO36                                   |            |
| EPI0S13                 |                    | D13                                   | PG0_GPIO40                                   |            | EPI0S13                 |                    | D13                                  | PG0_GPIO40                                   |            |
| EPI0S14                 |                    | D14                                   | PG1_GPIO41                                   |            | EPI0S14                 |                    | D14                                  | PG1_GPIO41                                   |            |
| EPI0S15                 |                    | D15                                   | PF5_GPIO37                                   |            | EPI0S15                 |                    | D15                                  | PF5_GPIO37                                   |            |
| EPI0S16                 |                    | A0                                    | PJ0_GPIO56                                   |            | EPI0S16                 |                    | A0                                   | PJ0_GPIO56                                   |            |
| EPI0S17                 |                    | A1                                    | PJ1_GPIO57                                   |            | EPI0S17                 |                    | A1                                   | PJ1_GPIO57                                   |            |
| EPI0S18                 |                    | A2                                    | PJ2_GPIO58                                   |            | EPI0S18                 |                    | A2                                   | PJ2_GPIO58                                   |            |
| EPI0S19                 |                    | A3                                    | PD4_GPIO20                                   | PJ3_GPIO59 | EPI0S19                 |                    | A3                                   | PD4_GPIO20                                   | PJ3_GPIO59 |
| EPI0S20                 |                    | A4                                    | PD2_GPIO18                                   |            | EPI0S20                 |                    | A4                                   | PD2_GPIO18                                   |            |
| EPI0S21                 |                    | A5                                    | PD3_GPIO19                                   |            | EPI0S21                 |                    | A5                                   | PD3_GPIO19                                   |            |
| EPI0S22                 |                    | A6                                    | PB5_GPIO13                                   |            | EPI0S22                 |                    | A6                                   | PB5_GPIO13                                   |            |
| EPI0S23                 |                    | A7                                    | PB4_GPIO12                                   |            | EPI0S23                 |                    | A7                                   | PB4_GPIO12                                   |            |
| EPI0S24                 |                    | A8                                    | PE2_GPIO26                                   |            | EPI0S24                 |                    | A8                                   | PE2_GPIO26                                   |            |
| EPI0S40                 |                    | A9                                    | PG5_GPIO45                                   |            | EPI0S40                 |                    | A9                                   | PG5_GPIO45                                   |            |
| EPI0S41                 |                    | A10                                   | PG6_GPIO46                                   |            | EPI0S41                 |                    | A10                                  | PG6_GPIO46                                   |            |
| EPI0S36                 |                    | A11                                   | PB7_GPIO15                                   | PC3_GPIO67 | EPI0S36                 |                    | A11                                  | PB7_GPIO15                                   | PC3_GPIO67 |
| EPI0S37                 |                    | A12                                   | PB6_GPIO14                                   | PC2_GPIO66 | EPI0S37                 |                    | A12                                  | PB6_GPIO14                                   | PC2_GPIO66 |
| EPI0S38                 |                    | A13                                   | PF6_GPIO38                                   | PE4_GPIO28 | EPI0S38                 |                    | A13                                  | PF6_GPIO38                                   | PE4_GPIO28 |
| EPI0S39                 |                    | A14                                   | PG2_GPIO42                                   |            | EPI0S39                 |                    | A14                                  | PG2_GPIO42                                   |            |
| EPI0S27                 |                    | A15                                   | PH7_GPIO55                                   |            | EPI0S25                 | BSEL0              | PE3_GPIO27                           |  |            |
| EPI0S35                 |                    | A16                                   | PE5_GPIO29                                   |            | EPI0S26                 | BSEL1              | PH6_GPIO54                           |  |            |
| EPI0S25                 |                    | BSEL0                                 | PE3_GPIO27                                   |            | EPI0S30                 | CS0                | PD7_GPIO23                           | PJ6_GPIO62                                   |            |
| EPI0S26                 |                    | BSEL1                                 | PH6_GPIO54                                   |            | EPI0S27                 | CS1                | PH7_GPIO55                           |  |            |
| EPI0S30                 |                    | CS0                                   | PD7_GPIO23                                   | PJ6_GPIO62 | EPI0S34                 | CS2                | PE4_GPIO28                           |  |            |
| EPI0S34                 |                    | CS2                                   | PE4_GPIO28                                   |            | EPI0S33                 | CS3                | PF3_GPIO35                           | PC1_GPIO65                                   |            |
| EPI0S33                 |                    | CS3                                   | PF3_GPIO35                                   | PC1_GPIO65 |                         |                    |                                      |  |            |
| EPI0S29                 |                    | WR                                    | PD6_GPIO22                                   | PJ5_GPIO61 | EPI0S29                 | WR                 | PD6_GPIO22                           | PJ5_GPIO61                                   |            |
| EPI0S28                 |                    | RD                                    | PD5_GPIO21                                   | PJ4_GPIO60 | EPI0S28                 | RD                 | PD5_GPIO21                           | PJ4_GPIO60                                   |            |
| EPI0S32                 |                    | RDY                                   | PF2_GPIO34                                   | PC0_GPIO64 | EPI0S32                 | RDY                | PF2_GPIO34                           | PC0_GPIO64                                   |            |
| EPI0S31                 |                    | x                                     | PG7_GPIO47                                   |            | EPI0S31                 | x                  | PG7_GPIO47                           |  |            |
|                         |                    |                                       |  |            | EPI0S35                 | x                  | PE5_GPIO29                           |  |            |

### 5.10.4.3.2.3 HB-16 FIFO Mode

The HB-16 FIFO Mode uses 16 bits of data, removes ALE and address pins, and optionally adds external FIFO Full/Empty flag inputs. This scheme is used by many devices, such as radios, communication devices (including USB2 devices), and some FPGA configuration (FIFO through block RAM). This FIFO Mode presents the data side of the normal Host-Bus interface, but is paced by FIFO control signals. It is important to consider that the FIFO Full/Empty control inputs may stall the EPI interface and can potentially block other CPU or DMA accesses. For detailed maps of the HB-16 FIFO Mode, see [Table 5-52](#).

**Table 5-52. EPI MODES – 16-Bit Host-Bus Mode (EPICFG/MODE = 0x3),  
FIFO Mode (EPIHB16CFG/MODE = 0x3)**

| EPI PORT NAME           |                    | EPI SIGNAL FUNCTION                |                                     | DEVICE PIN                                   |
|-------------------------|--------------------|------------------------------------|-------------------------------------|--|
| ACCESSIBLE BY Cortex-M3 | ACCESSIBLE BY C28x | WITH ONE CHIP SELECT (CSCFG = 0x1) | WITH TWO CHIP SELECTS (CSCFG = 0x2) | (AVAILABLE GPIOMUX 1 MUXING CHOICES FOR EPI) |
|                         | EPI0S0             | D0                                 | D0                                  | PH3_GPIO51                                   |
|                         | EPI0S1             | D1                                 | D1                                  | PH2_GPIO50                                   |
|                         | EPI0S2             | D2                                 | D2                                  | PC4_GPIO68                                   |
|                         | EPI0S3             | D3                                 | D3                                  | PC5_GPIO69                                   |
|                         | EPI0S4             | D4                                 | D4                                  | PC6_GPIO70                                   |
|                         | EPI0S5             | D5                                 | D5                                  | PC7_GPIO71                                   |
|                         | EPI0S6             | D6                                 | D6                                  | PH0_GPIO48                                   |
|                         | EPI0S7             | D7                                 | D7                                  | PH1_GPIO49                                   |
|                         | EPI0S8             | D8                                 | D8                                  | PE0_GPIO24                                   |
|                         | EPI0S9             | D9                                 | D9                                  | PE1_GPIO25                                   |
|                         | EPI0S10            | D10                                | D10                                 | PH4_GPIO52                                   |
|                         | EPI0S11            | D11                                | D11                                 | PH5_GPIO53                                   |
|                         | EPI0S12            | D12                                | D12                                 | PF4_GPIO36                                   |
|                         | EPI0S13            | D13                                | D13                                 | PG0_GPIO40                                   |
|                         | EPI0S14            | D14                                | D14                                 | PG1_GPIO41                                   |
|                         | EPI0S15            | D15                                | D15                                 | PF5_GPIO37                                   |
|                         |                    |                                    |                                     |  |
|                         | EPI0S25            | x                                  | $\overline{CS1}$                    | PE3_GPIO27                                   |
|                         | EPI0S30            | $\overline{CS0}$                   | $\overline{CS0}$                    | PD7_GPIO23 PJ6_GPIO62                        |
|                         |                    |                                    |                                     |  |
|                         | EPI0S27            | FFULL                              | FFULL                               | PH7_GPIO55                                   |
|                         | EPI0S26            | FEMPTY                             | FEMPTY                              | PH6_GPIO54                                   |
|                         | EPI0S29            | WR                                 | WR                                  | PD6_GPIO22 PJ5_GPIO61                        |
|                         | EPI0S28            | RD                                 | RD                                  | PD5_GPIO21 PJ4_GPIO60                        |
|                         | EPI0S32            | x                                  | x                                   | PF2_GPIO34 PC0_GPIO64                        |
|                         |                    |                                    |                                     |  |
|                         | EPI0S16            | x                                  | x                                   | PJ0_GPIO56                                   |
|                         | EPI0S17            | x                                  | x                                   | PJ1_GPIO57                                   |
|                         | EPI0S18            | x                                  | x                                   | PJ2_GPIO58                                   |
|                         | EPI0S19            | x                                  | x                                   | PD4_GPIO20 PJ3_GPIO59                        |
|                         | EPI0S20            | x                                  | x                                   | PD2_GPIO18                                   |
|                         | EPI0S21            | x                                  | x                                   | PD3_GPIO19                                   |
|                         | EPI0S22            | x                                  | x                                   | PB5_GPIO13                                   |
|                         | EPI0S23            | x                                  | x                                   | PB4_GPIO12                                   |
|                         | EPI0S24            | x                                  | x                                   | PE2_GPIO26                                   |
|                         | EPI0S31            | x                                  | x                                   | PG7_GPIO47                                   |

**Table 5-52. EPI MODES – 16-Bit Host-Bus Mode (EPICFG/MODE = 0x3),  
FIFO Mode (EPIHB16CFG/MODE = 0x3) (continued)**

| EPI PORT NAME              |                       | EPI SIGNAL FUNCTION                      |   | DEVICE PIN                                      |            |
|----------------------------|-----------------------|--|---|---|------------|
| ACCESSIBLE BY<br>Cortex-M3 | ACCESSIBLE BY<br>C28x | WITH ONE<br>CHIP SELECT<br>(CSCFG = 0x1) | WITH TWO<br>CHIP SELECTS<br>(CSCFG = 0x2) | (AVAILABLE GPIOMUX_1<br>MUXING CHOICES FOR EPI) |            |
|                            | EPI0S33               | x  | x   | PF3_GPIO35                                      | PC1_GPIO65 |
|                            | EPI0S34               | x  | x   | PE4_GPIO28                                      |            |
|                            | EPI0S35               | x  | x   | PE5_GPIO29                                      |            |
|                            | EPI0S36               | x  | x   | PB7_GPIO15                                      | PC3_GPIO67 |
|                            | EPI0S37               | x  | x   | PB6_GPIO14                                      | PC2_GPIO66 |
|                            | EPI0S38               | x  | x   | PF6_GPIO38                                      | PE4_GPIO28 |
|                            | EPI0S39               | x  | x   | PG2_GPIO42                                      |            |
|                            | EPI0S40               | x  | x   | PG5_GPIO45                                      |            |
|                            | EPI0S41               | x  | x   | PG6_GPIO46                                      |            |

#### 5.10.4.4 EPI Electrical Data and Timing

The signal names in [Figure 5-22](#) through [Figure 5-30](#) are defined in [Table 5-53](#).

**Table 5-53. Signals in [Figure 5-22](#) Through [Figure 5-30](#)**

| SIGNAL  | DESCRIPTION               |
|---|---------------------------|
| AD  | Address/Data              |
| Address   | Address output            |
| ALE   | Address latch enable      |
| BAD   | Bank Address/Data         |
| $\overline{\text{BSEL0}}$ , $\overline{\text{BSEL1}}$ | Byte select               |
| $\overline{\text{CAS}}$                               | Column address strobe     |
| CKE   | Clock enable              |
| CLK, Clock  | Clock                     |
| Command   | Command signal            |
| $\overline{\text{CS}}$                                | Chip select               |
| Data  | Data signals              |
| DQMH  | Data mask high            |
| DQML  | Data mask low             |
| Frame   | Frame signal              |
| iRDY  | Ready input               |
| Muxed Address/Data                                    | Multiplexed Address/Data  |
| $\overline{\text{RAS}}$                               | Row address strobe        |
| $\overline{\text{RD/OE}}$                             | Read enable/Output enable |
| $\overline{\text{WE}}$ , $\overline{\text{WR}}$       | Write enable              |

**Table 5-54. EPI SDRAM Interface Switching Characteristics Over Recommended Operating Conditions (Unless Otherwise Noted) (see Figure 5-22, Figure 5-23, and Figure 5-24)**

| NO. | PARAMETER       | MIN | MAX | UNIT    |
|-----|-----------------|-----|-----|---------|
| E1  | $t_{c(CK)}$     |     |     | ns      |
| E2  | $t_{w(CKH)}$    |     |     | ns      |
| E3  | $t_{w(CKL)}$    |     |     | ns      |
| E4  | $t_{d(CK-OV)}$  | -5  | 5   | ns      |
| E5  | $t_{d(CK-OIV)}$ | -5  | 5   | ns      |
| E6  | $t_{d(CK-OZ)}$  | -5  | 5   | ns      |
| E7  | $t_{su(AD-CK)}$ | 10  |     | ns      |
| E8  | $t_{h(CK-AD)}$  | 0   |     | ns      |
| E9  | $t_{pU}$        | 100 |     | $\mu$ s |
| E10 | $t_{pc}$        | 20  |     | ns      |
| E11 | $t_{rf}$        | 66  |     | ns      |
| E12 | $t_{MRD}$       | 40  |     | ns      |

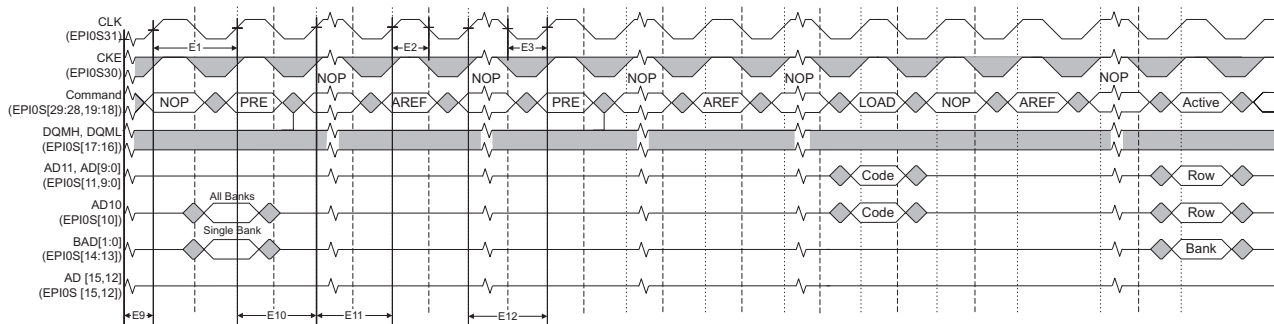

- A. If CS is high at clock high time, all applied commands are NOP.
- B. The Mode register may be loaded before the autorefresh cycles if desired.
- C. JEDEC and PC100 specify three clocks.
- D. Outputs are ensured High-Z after command is issued.

**Figure 5-22. SDRAM Initialization and Load Mode Register Timing**

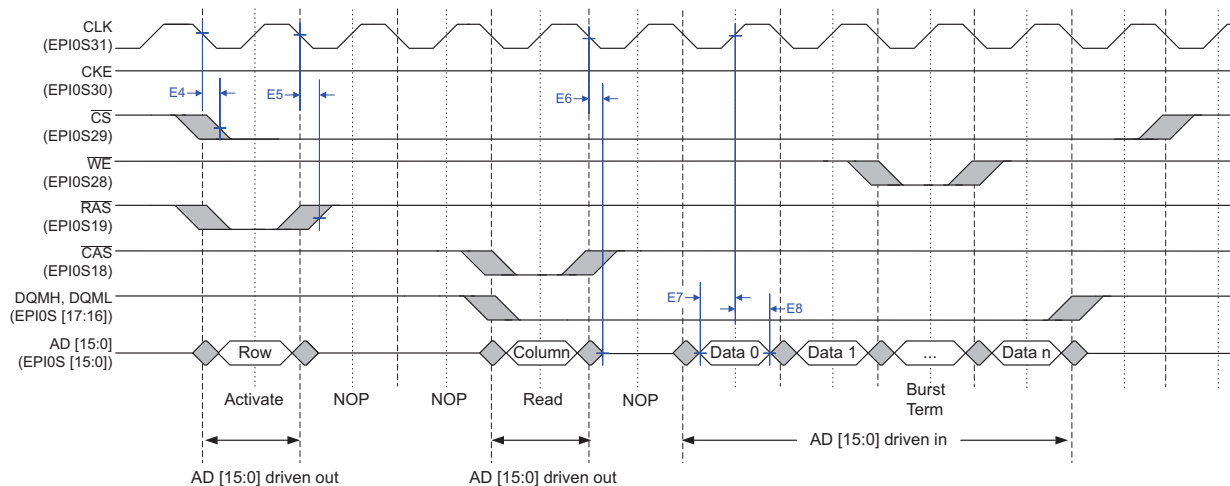

**Figure 5-23. SDRAM Read Timing**

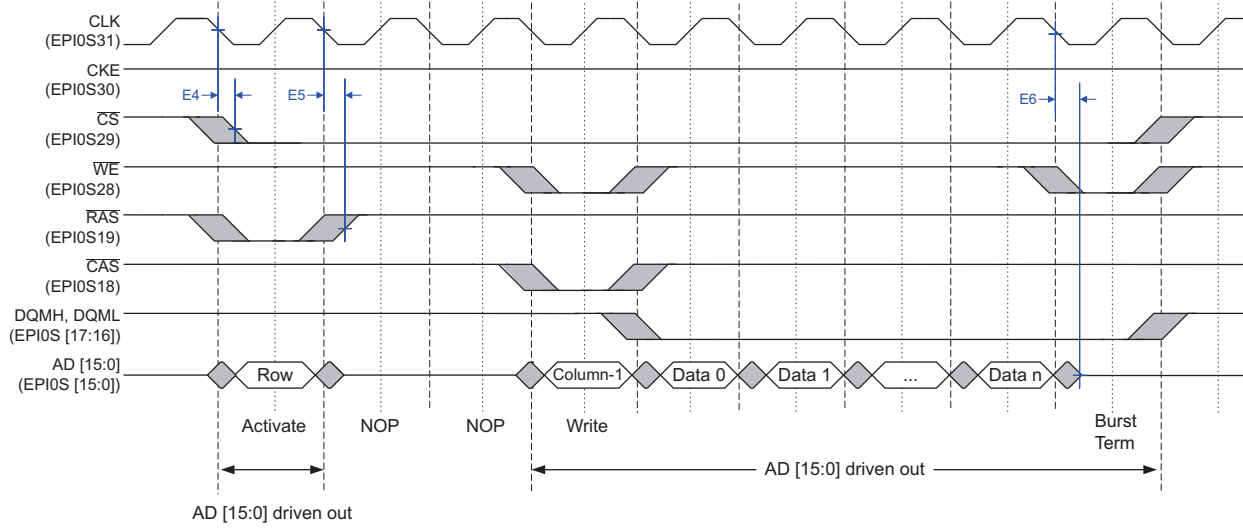

**Figure 5-24. SDRAM Write Timing**

**Table 5-55. EPI Host-Bus 8 and Host-Bus 16 Interface Switching Characteristics Over Recommended Operating Conditions (Unless Otherwise Noted)**  
(see [Figure 5-25](#), [Figure 5-26](#), [Figure 5-27](#), and [Figure 5-28](#))

| NO. | PARAMETER  | MIN | TYP | MAX | UNIT       |
|-----|--|-----|-----|-----|------------|
| E16 | $t_{d(WR-WDATAV)}$ Delay time, $\overline{WR}$ to write data valid                     |     |     | 5   | ns         |
| E17 | $t_{d(WRIV-DATA)}$ Delay time, $\overline{WR}$ invalid to data                         | 2   |     |     | EPI clocks |
| E18 | $t_{d(CS-OV)}$ Delay time, $\overline{CS}$ to output valid                             | -5  |     | 5   | ns         |
| E19 | $t_{d(CS-OIV)}$ Delay time, $\overline{CS}$ to output invalid                          | -5  |     | 5   | ns         |
| E20 | $t_{w(STL)}$ Pulse duration, $\overline{WR}/\overline{RD}$ strobe low                  | 2   |     |     | EPI clocks |
| E22 | $t_{w(ALEH)}$ Pulse duration, ALE high   |     | 1   |     | EPI clocks |
| E23 | $t_{w(CSL)}$ Pulse duration, $\overline{CS}$ low                                       | 4   |     |     | EPI clocks |
| E24 | $t_{d(ALE-ST)}$ Delay time, ALE rising to $\overline{WR}/\overline{RD}$ strobe falling | 2   |     |     | EPI clocks |
| E25 | $t_{d(ALE-ADHZ)}$ Delay time, ALE falling to Address/Data high-impedance               | 1   |     |     | EPI clocks |

**Table 5-56. EPI Host-Bus 8 and Host-Bus 16 Interface Timing Requirements<sup>(1)</sup>**  
(see [Figure 5-25](#) and [Figure 5-27](#))

| NO. | PARAMETER                             | MIN | MAX | UNIT |
|-----|---------------------------------------|-----|-----|------|
| E14 | $t_{su(RDATA)}$ Setup time, read data | 10  |     | ns   |
| E15 | $t_{h(RDATA)}$ Hold time, read data   | 0   |     | ns   |

(1) Setup time for FEMPTY and FFULL signals from clock edge is 2 system clocks (MIN).

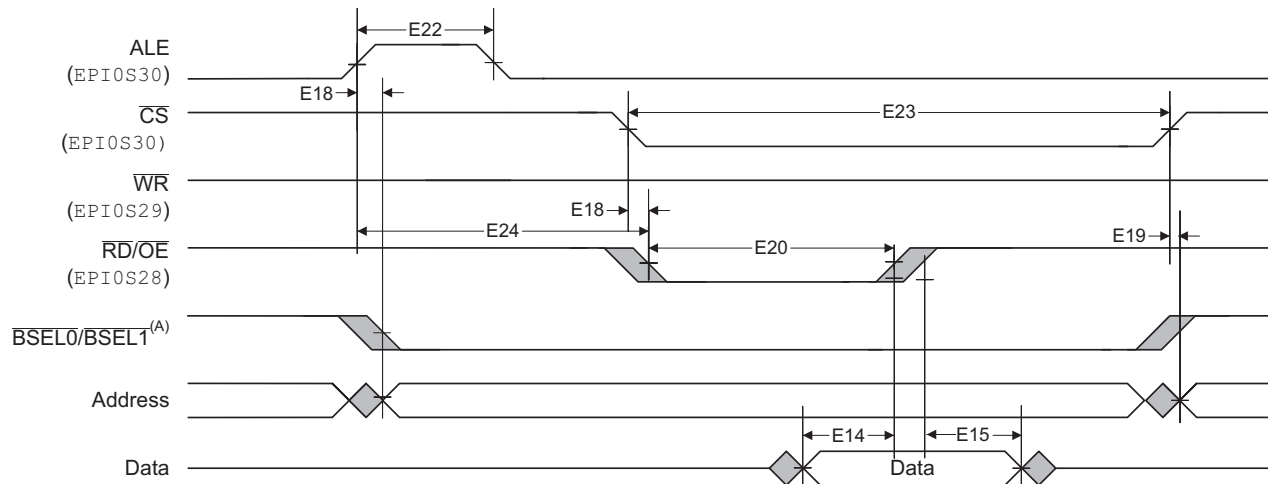

A.  $\overline{BSEL0}$  and  $\overline{BSEL1}$  are available in Host-Bus 16 mode only.

**Figure 5-25. Host-Bus 8/16 Mode Read Timing**

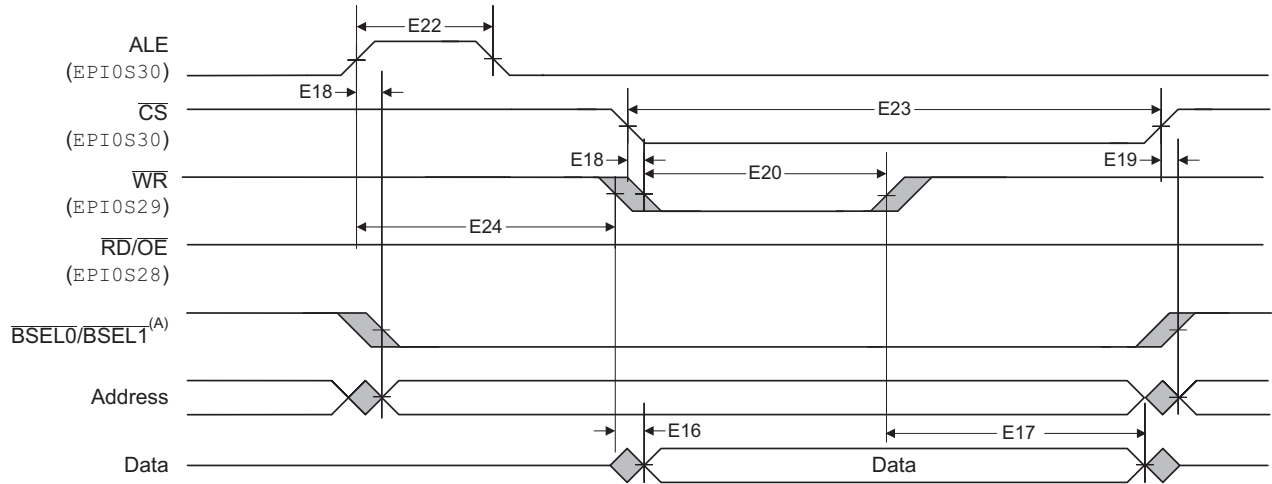

A. BSEL0 and BSEL1 are available in Host-Bus 16 mode only.

Figure 5-26. Host-Bus 8/16 Mode Write Timing

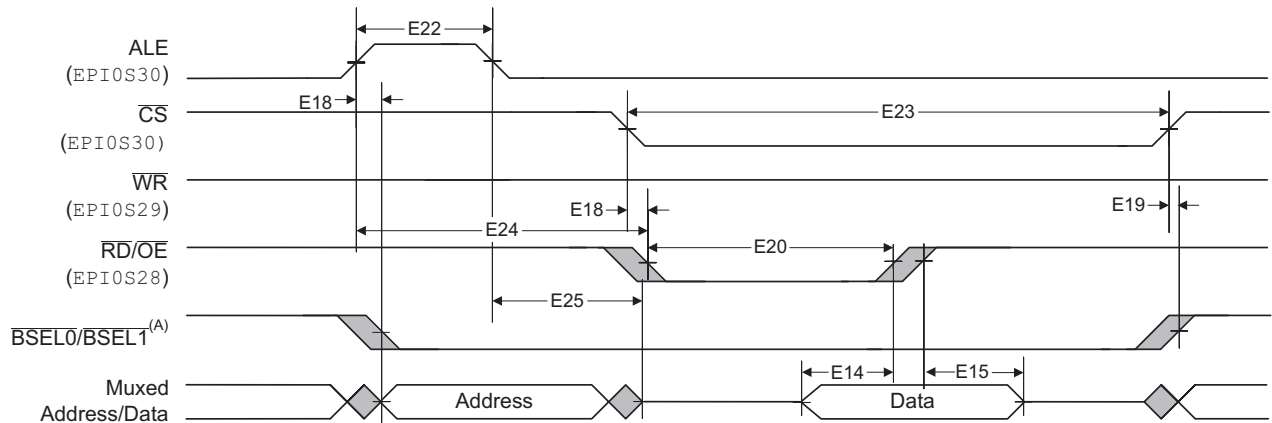

A. BSEL0 and BSEL1 are available in Host-Bus 16 mode only.

Figure 5-27. Host-Bus 8/16 Mode Muxed Read Timing

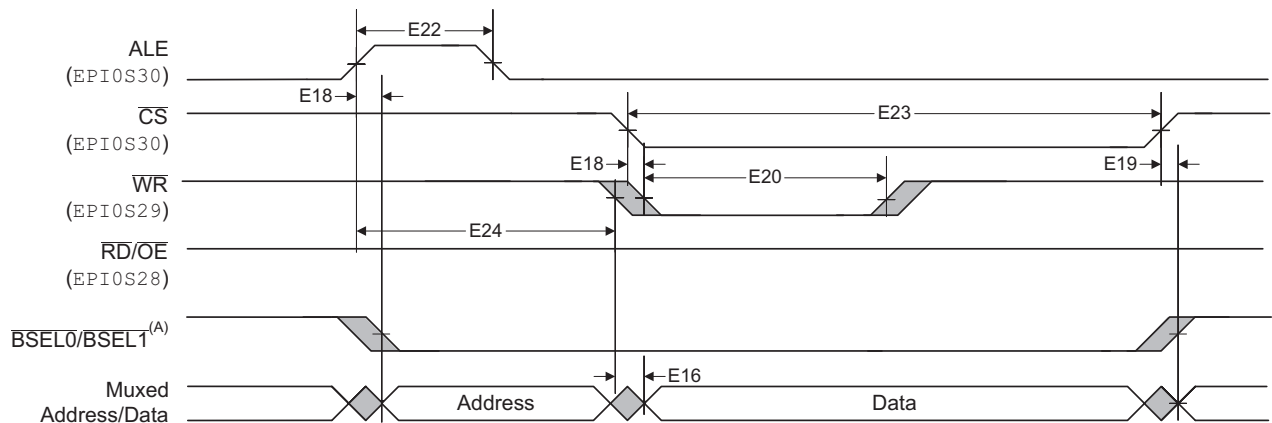

A. BSEL0 and BSEL1 are available in Host-Bus 16 mode only.

Figure 5-28. Host-Bus 8/16 Mode Muxed Write Timing

**Table 5-57. EPI General-Purpose Interface Switching Characteristics Over Recommended Operating Conditions (Unless Otherwise Noted) (see Figure 5-29)**

| NO. | PARAMETER       |  | MIN | MAX | UNIT |
|-----|-----------------|--|-----|-----|------|
| E26 | $t_{w(CKH)}$    | Pulse duration, general-purpose clock high       | 10  |     | ns   |
| E27 | $t_{w(CKL)}$    | Pulse duration, general-purpose clock low        | 10  |     | ns   |
| E30 | $t_{d(CK-OV)}$  | Delay time, falling clock edge to output valid   | -5  | 5   | ns   |
| E31 | $t_{d(CK-OIV)}$ | Delay time, falling clock edge to output invalid | -5  | 5   | ns   |
| E33 | $t_c(CK)$       | Cycle time, general-purpose clock                | 20  |     | ns   |

**Table 5-58. EPI General-Purpose Interface Timing Requirements (see Figure 5-29 and Figure 5-30)**

| NO. | PARAMETER         |   | MIN | MAX | UNIT |
|-----|-------------------|---|-----|-----|------|
| E28 | $t_{su(IN-CK)}$   | Setup time, input signal before rising clock edge                   | 10  |     | ns   |
| E29 | $t_h(CK-IN)$      | Hold time, input signal after rising clock edge                     | 0   |     | ns   |
| E32 | $t_{su(IRDY-CK)}$ | Setup time, iRDY assertion or deassertion before falling clock edge | 10  |     | ns   |

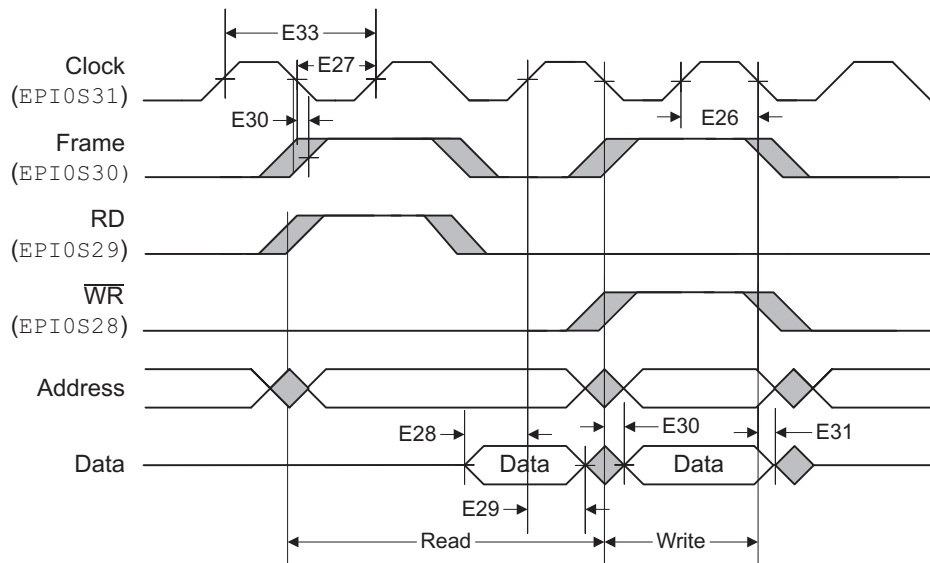

A. This figure illustrates accesses where the FRM50 bit is clear, the FRMCNT field is 0x0, the RD2CYC bit is clear, and the WR2CYC bit is clear.

**Figure 5-29. General-Purpose Mode Read and Write Timing**

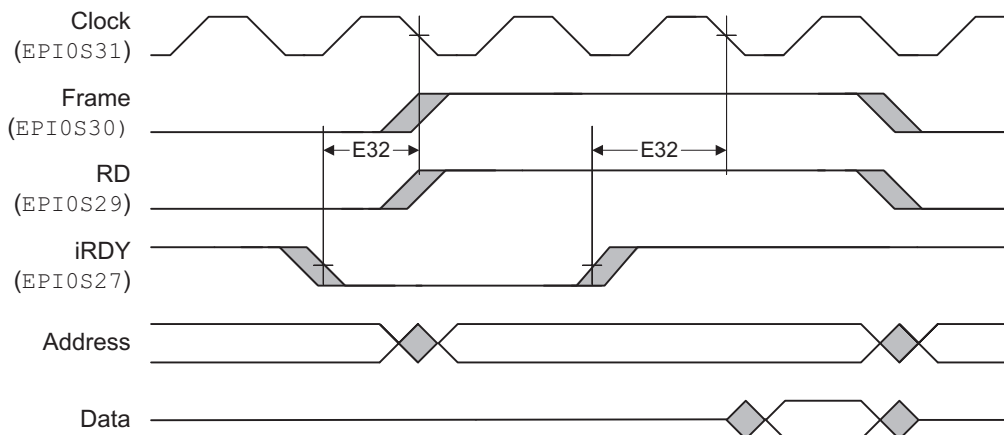

**Figure 5-30. General-Purpose Mode iRDY Timing**

## 5.11 Master Subsystem Peripherals

Master Subsystem peripherals are located on the APB Bus and AHB Bus, and are accessible from the Cortex-M3 CPU/μDMA. The AHB peripherals include EPI, USB, and two CAN modules. The APB peripherals include EMAC, two I2Cs, five UARTs, four SSIs, four GPTIMERS, two WDOGs, NMI WDOG, and a μCRC module (Cyclic Redundancy Check). The Cortex-M3 CPU/μDMA also have access to Analog (Result Registers only) and Shared peripherals (see [Section 5.10](#)).

For detailed information on the processor peripherals, see the [Concerto F28M35x Technical Reference Manual](#).

### 5.11.1 Synchronous Serial Interface

This device has four SSI modules. Each SSI has a Master or Slave interface for synchronous serial communication with peripheral devices that have Texas Instruments™ SSIs, SPI, or Freescale™ serial format.

The SSI peripheral performs serial-to-parallel conversion on data received from a peripheral device. The CPU accesses data, control, and status information. The transmit and receive paths are buffered with internal FIFO memories, allowing up to eight 16-bit values to be stored independently in both transmit and receive modes. The SSI also supports μDMA transfers. The transmit and receive FIFOs can be programmed as destination/source addresses in the μDMA module. An μDMA operation is enabled by setting the appropriate bit or bits in the SSIDMACTL register.

[Figure 5-31](#) shows the SSI peripheral.

#### 5.11.1.1 Bit Rate Generation

The SSI includes a programmable bit-rate clock divider and prescaler to generate the serial output clock. Bit rates are supported to 2 MHz and higher, although maximum bit rate is determined by peripheral devices. The serial bit rate is derived by dividing-down the input clock (SysClk). The clock is first divided by an even prescale value CPSDVSR from 2 to 254, which is programmed in the SSI Clock Prescale (SSICPSR) register. The clock is further divided by a value from 1 to 256, which is 1 + SCR, where SCR is the value programmed in the SSI Control 0 (SSICR0) register. The frequency of the output clock SSIClk is defined by:

$$\text{SSIClk} = \text{SysClk} / [\text{CPSDVSR} * (1 + \text{SCR})]$$

---

#### NOTE

For master mode, the system clock must be at least four times faster than SSIClk, with the restriction that SSIClk cannot be faster than 25 MHz. For slave mode, the system clock must be at least 12 times faster than SSIClk.

---

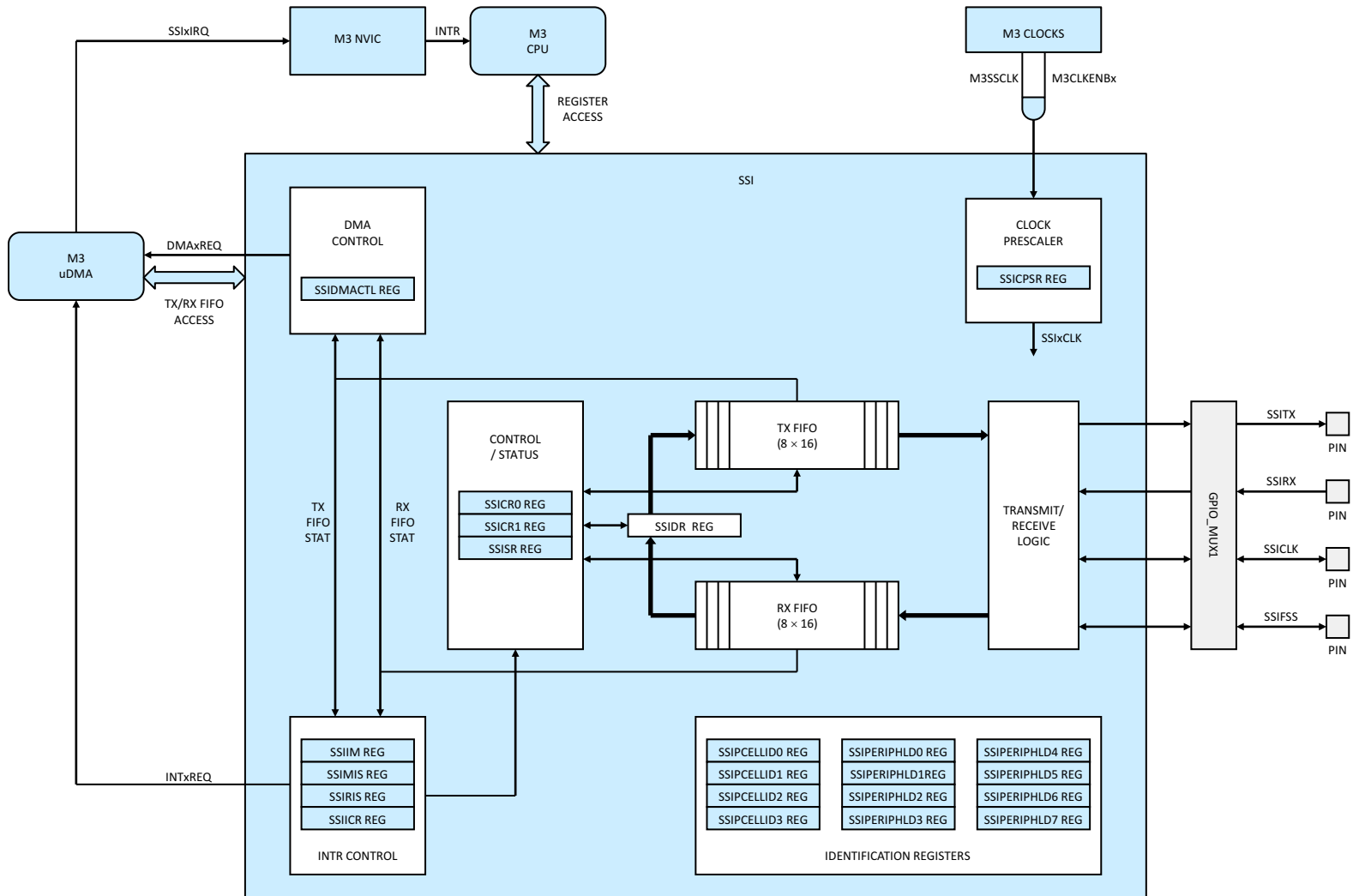

Figure 5-31. SSI

### 5.11.1.2 Transmit FIFO

The transmit FIFO is a 16-bit-wide, 8-location-deep, first-in, first-out memory buffer. The CPU writes data to the FIFO through the SSI Data (SSIDR) register, and data is stored in the FIFO until the data is read out by the transmission logic. When configured as a master or a slave, parallel data is written into the transmit FIFO before serial conversion and transmission to the attached slave or master, respectively, through the SSITx pin.

In slave mode, the SSI transmits data each time the master initiates a transaction. If the transmit FIFO is empty and the master initiates a transaction, the slave transmits the 8th most recent value in the transmit FIFO. If less than eight values have been written to the transmit FIFO since the SSI module clock was enabled using the SSI bit in the RGCG1 register, then "0" is transmitted. Care should be taken to ensure that valid data is in the FIFO as needed. The SSI can be configured to generate an interrupt or an  $\mu$ DMA request when the FIFO is empty.

### 5.11.1.3 Receive FIFO

The receive FIFO is a 16-bit-wide, 8-location-deep, first-in, first-out memory buffer. Received data from the serial interface is stored in the buffer until read out by the CPU, which accesses the read FIFO by reading the SSIDR register. When configured as a master or slave, serial data received through the SSIRx pin is registered before parallel loading into the attached slave or master receive FIFO, respectively.

### 5.11.1.4 Interrupts

The SSI can generate interrupts when the following conditions are observed:

- Transmit FIFO service (when the transmit FIFO is half full or less)
- Receive FIFO service (when the receive FIFO is half full or more)
- Receive FIFO time-out
- Receive FIFO overrun
- End of transmission

All of the interrupt events are ORed together before being sent to the interrupt controller, so the SSI generates a single interrupt request to the controller regardless of the number of active interrupts. Each of the four individual maskable interrupts can be masked by clearing the appropriate bit in the SSI Interrupt Mask (SSIIM) register. Setting the appropriate mask bit enables the interrupt.

The individual outputs, along with a combined interrupt output, allow the use of either a global interrupt service routine or modular device drivers to handle interrupts. The transmit and receive dynamic data-flow interrupts have been separated from the status interrupts so that data can be read or written in response to the FIFO trigger levels. The status of the individual interrupt sources can be read from the SSI Raw Interrupt Status (SSIRIS) and SSI Masked Interrupt Status (SSIMIS) registers.

The receive FIFO has a time-out period that is 32 periods at the rate of SSIClk (whether or not SSIClk is currently active) and is started when the RX FIFO goes from EMPTY to not-EMPTY. If the RX FIFO is emptied before 32 clocks have passed, the time-out period is reset. As a result, the ISR should clear the Receive FIFO Time-out Interrupt just after reading out the RX FIFO by writing a "1" to the RTIC bit in the SSI Interrupt Clear (SSIICR) register. The interrupt should not be cleared so late that the ISR returns before the interrupt is actually cleared, or the ISR may be reactivated unnecessarily.

The End-of-Transmission (EOT) interrupt indicates that the data has been transmitted completely. This interrupt can be used to indicate when it is safe to turn off the SSI module clock or enter sleep mode. In addition, because transmitted data and received data complete at exactly the same time, the interrupt can also indicate that read data is ready immediately, without waiting for the receive FIFO time-out period to complete.

#### 5.11.1.5 Frame Formats

Each data frame is between 4 bits and 16 bits long, depending on the size of data programmed, and is transmitted starting with the MSB. The following basic frame types can be selected:

- Texas Instruments Synchronous Serial
- Freescale SPI

For all three formats, the serial clock (SSIClk) is held inactive while the SSI is idle, and SSIClk transitions at the programmed frequency only during active transmission or reception of data. The idle state of SSIClk is used to provide a receive time-out indication that occurs when the receive FIFO still contains data after a time-out period.

### 5.11.2 Universal Asynchronous Receiver/Transmitter

This device has five UART modules. The CPU accesses data, control, and status information. The UART also supports  $\mu$ DMA transfers. Each UART performs functions of parallel-to-serial and serial-to-parallel conversions. Each of the five UART modules is similar in functionality to a 16C550 UART, but is not register-compatible.

The UART is configured for transmit and receive through the TXE bit and the RXE bit, respectively, of the UART Control (UARTCTL) register. Transmit and receive are both enabled out of reset. Before any control registers are programmed, the UART must be disabled by clearing the URTEN bit in UARTCTL. If the UART is disabled during a TX or RX operation, the current transaction is completed before the UART stops.

The UART module also includes a serial IR (SIR) encoder/decoder block that can be connected to an infrared transceiver to implement an IrDA SIR physical layer. The SIR function is programmed using the UARTCTL register.

Figure 5-32 shows the UART peripheral.

#### 5.11.2.1 Baud-Rate Generation

The baud-rate divisor is a 22-bit number consisting of a 16-bit integer and a 6-bit fractional part. The number formed by these two values is used by the baud-rate generator to determine the bit period. Having a fractional baud-rate divider allows the UART to generate all the standard baud rates.

The 16-bit integer is loaded through the UART Integer Baud-Rate Divisor (UARTIBRD) register, and the 6-bit fractional part is loaded with the UART Fractional Baud-Rate Divisor (UARTFBRD) register. The baud rate divisor (BRD) has the following relationship to the system clock (where BRDI is the integer part of the BRD, and BRDF is the fractional part, separated by a decimal place).

$$\text{BRD} = \text{BRDI} + \text{BRDF} = \text{UARTSysClk} / (\text{ClkDiv} * \text{Baud Rate})$$

where UARTSysClk is the system clock connected to the UART, and ClkDiv is either 16 (if HSE in UARTCTL is clear) or 8 (if HSE is set).

The 6-bit fractional number (that is to be loaded into the DIVFRAC bit field in the UARTFBRD register) can be calculated by taking the fractional part of the baud-rate divisor, multiplying this fractional part by 64, and adding 0.5 to account for rounding errors:

$$\text{UARTFBRD}[\text{DIVFRAC}] = \text{integer}(\text{BRDF} * 64 + 0.5)$$

The UART generates an internal baud-rate reference clock at 8x or 16x the baud rate [referred to as Baud8 and Baud16, depending on the setting of the HSE bit (bit 5 in UARTCTL)]. This reference clock is divided by 8 or 16 to generate the transmit clock, and is used for error detection during receive operations.

Along with the UART Line Control, High Byte (UARTLCRH) register, the UARTIBRD and UARTFBRD registers form an internal 30-bit register. This internal register is only updated when a write operation to UARTLCRH is performed, so any changes to the baud-rate divisor must be followed by a write to the UARTLCRH register for the changes to take effect.

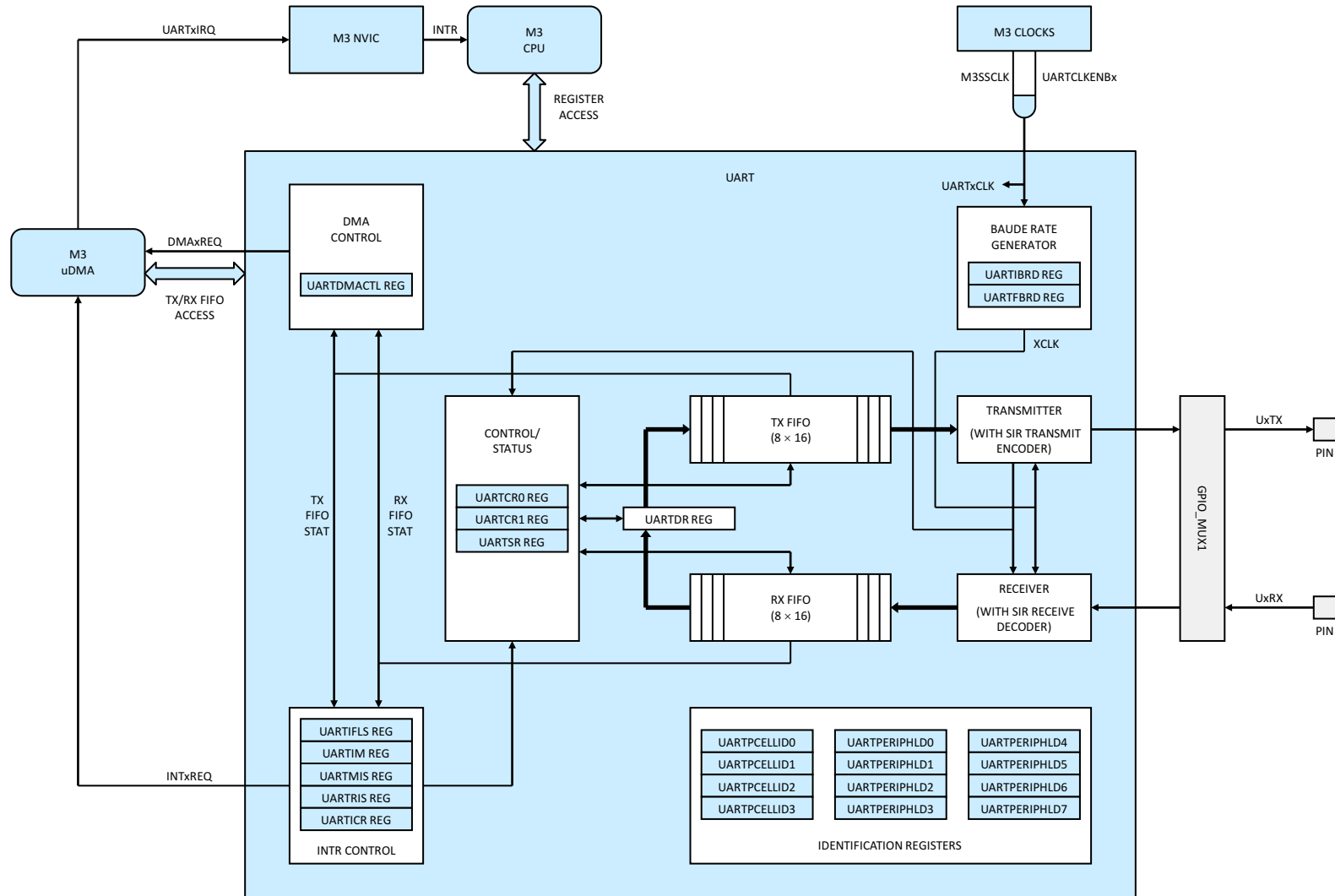

Figure 5-32. UART

### 5.11.2.2 Transmit and Receive Logic

The transmit logic performs parallel-to-serial conversion on the data read from the transmit FIFO. The control logic outputs the serial bit stream beginning with a start bit and followed by the data bits (LSB first), parity bit, and the stop bits according to the programmed configuration in the control registers.

The receive logic performs serial-to-parallel conversion on the received bit stream after a valid start pulse has been detected. Overrun, parity, frame error checking, and line-break detection are also performed, and their status accompanies the data that is written to the receive FIFO.

### 5.11.2.3 Data Transmission and Reception

Data received or transmitted is stored in two 16-byte FIFOs, though the receive FIFO has an extra 4 bits per character for status information. For transmission, data is written into the transmit FIFO. If the UART is enabled, a data frame starts transmitting with the parameters indicated in the UARTLCRH register. Data continues to be transmitted until there is no data left in the transmit FIFO. The BUSY bit in the UART Flag (UARTFR) register is asserted as soon as data is written to the transmit FIFO (that is, if the FIFO is nonempty) and remains asserted while data is being transmitted. The BUSY bit is negated only when the transmit FIFO is empty, and the last character has been transmitted from the shift register, including the stop bits. The UART can indicate that it is busy even though the UART may no longer be enabled.

When the receiver is idle (the UnRx signal is continuously "1"), and the data input goes Low (a start bit has been received), the receive counter begins running and data is sampled on the eighth cycle of Baud16 or the fourth cycle of Baud8, depending on the setting of the HSE bit (bit 5 in UARTCTL).

The start bit is valid and recognized if the UnRx signal is still low on the eighth cycle of Baud16 (HSE clear) or the fourth cycle of Baud 8 (HSE set), otherwise the start bit is ignored. After a valid start bit is detected, successive data bits are sampled on every 16th cycle of Baud16 or 8th cycle of Baud8 (that is, 1 bit period later), according to the programmed length of the data characters and value of the HSE bit in UARTCTL. The parity bit is then checked if parity mode is enabled. Data length and parity are defined in the UARTLCRH register.

Lastly, a valid stop bit is confirmed if the UnRx signal is High, otherwise a framing error has occurred. When a full word is received, the data is stored in the receive FIFO along with any error bits associated with that word.

#### 5.11.2.4 Interrupts

The UART can generate interrupts when the following conditions are observed:

- Overrun Error
- Break Error
- Parity Error
- Framing Error
- Receive Time-out
- Transmit (when the condition defined in the TXIFLSEL bit in the UARTIFLS register is met, or if the EOT bit in UARTCTL is set, when the last bit of all transmitted data leaves the serializer)
- Receive (when the condition defined in the RXIFLSEL bit in the UARTIFLS register is met)

All of the interrupt events are ORed together before being sent to the interrupt controller, so the UART can only generate a single interrupt request to the controller at any given time. Software can service multiple interrupt events in a single interrupt service routine by reading the UART Masked Interrupt Status (UARTMIS) register.

The interrupt events that can trigger a controller-level interrupt are defined in the UART Interrupt Mask (UARTIM) register by setting the corresponding IM bits. If interrupts are not used, the raw interrupt status is always visible through the UART Raw Interrupt Status (UARTRIS) register.

Interrupts are always cleared (for both the UARTMIS and UARTRIS registers) by writing a "1" to the corresponding bit in the UART Interrupt Clear (UARTICR) register.

The receive time-out interrupt is asserted when the receive FIFO is not empty, and no further data is received over a 32-bit period. The receive time-out interrupt is cleared either when the FIFO becomes empty through reading all the data (or by reading the holding register), or when a "1" is written to the corresponding bit in the UARTICR register.

### 5.11.3 Cortex-M3 Inter-Integrated Circuit

This device has two Cortex-M3 I2C peripherals. The Cortex-M3 I2C bus provides bidirectional data transfer through a two-wire design (a serial data line SDA and a serial clock line SCL), and interfaces to external I2C devices such as serial memory (RAMs and ROMs), networking devices, LCDs, tone generators, and so on. The I2C bus may also be used for system testing and diagnostic purposes in product development and manufacture. The microcontroller includes two I2C modules, providing the ability to interact (both transmit and receive) with other I2C devices on the bus.

The two Cortex-M3 I2C modules include the following features:

- Devices on the I2C bus can be designated as either a master or a slave
  - Supports both transmitting and receiving data as either a master or a slave
  - Supports simultaneous master and slave operation
- Four I2C modes
  - Master transmit
  - Master receive
  - Slave transmit
  - Slave receive
- Two transmission speeds: Standard (100 Kbps) and Fast (400 Kbps)
- Master and slave interrupt generation
  - Master generates interrupts when a transmit or receive operation completes (or aborts due to an error)
  - Slave generates interrupts when data has been transferred or requested by a master or when a START or STOP condition is detected
- Master with arbitration and clock synchronization, multimaster support, and 7-bit addressing mode

Figure 5-33 shows the Cortex-M3 I2C peripheral.

#### 5.11.3.1 Functional Overview

Each I2C module comprises both master and slave functions. For proper operation, the SDA and SCL pins must be configured as open-drain signals.

The I2C bus uses only two signals: SDA and SCL, named I2CSDA and I2CSCL. SDA is the bidirectional serial data line and SCL is the bidirectional serial clock line. The bus is considered idle when both lines are high.

Every transaction on the I2C bus is 9 bits long, consisting of eight data bits and a single acknowledge bit. The number of bytes per transfer (defined as the time between a valid START and STOP condition) is unrestricted, but each byte has to be followed by an acknowledge bit, and data must be transferred MSB first. When a receiver cannot receive another complete byte, the receiver can hold the clock line SCL Low and force the transmitter into a wait state. The data transfer continues when the receiver releases the clock SCL.

#### 5.11.3.2 Available Speed Modes

The I2C bus can run in either standard mode (100 Kbps) or fast mode (400 Kbps). The selected mode should match the speed of the other I2C devices on the bus.

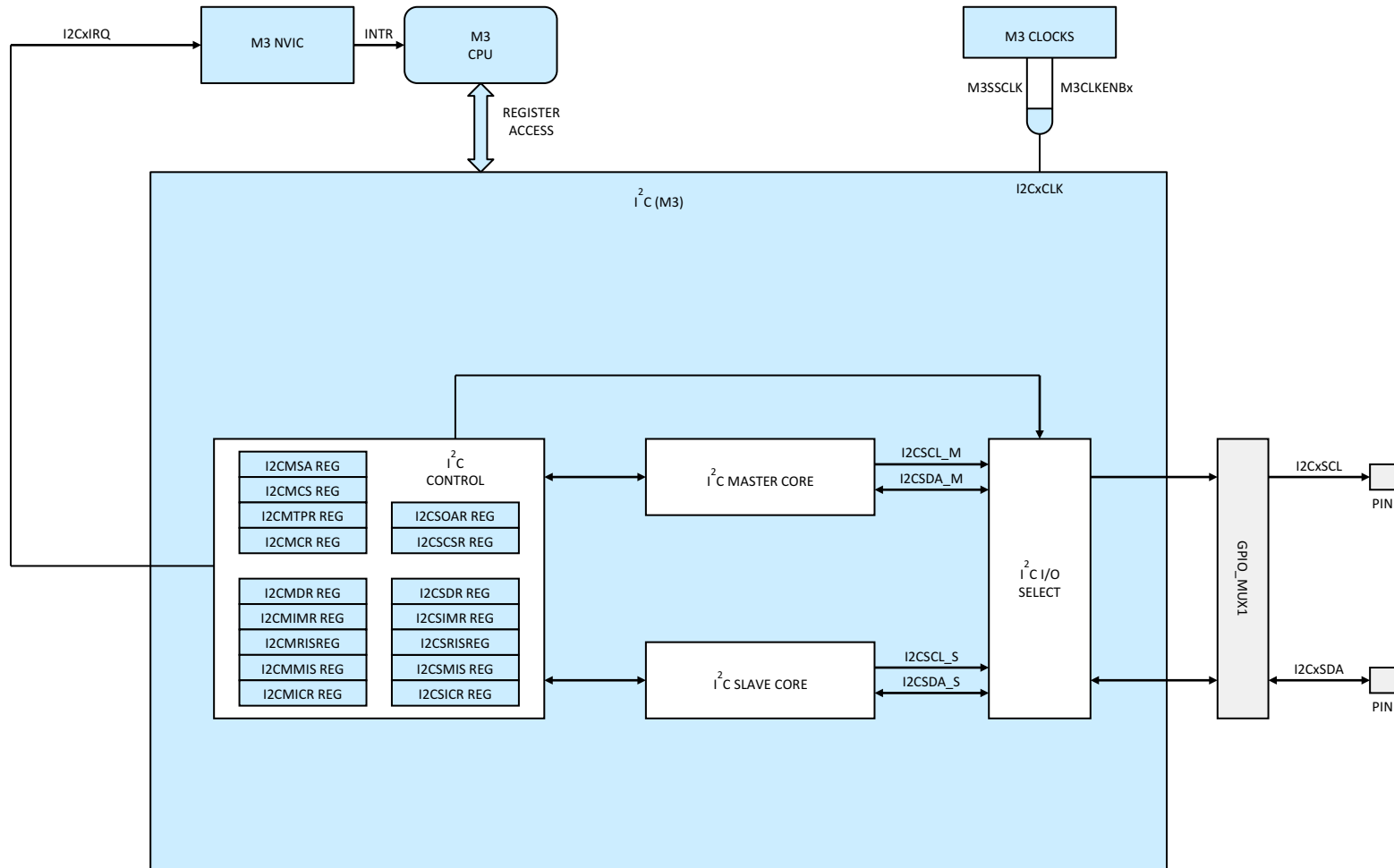

Figure 5-33. I2C (Cortex-M3)

### 5.11.3.3 I2C Electrical Data and Timing

**Table 5-59. I2C Timing**

|            |   | TEST CONDITIONS   | MIN             | MAX            | UNIT    |
|------------|---|---|-----------------|----------------|---------|
| $f_{SCL}$  | SCL clock frequency   | I2C clock module frequency is between 7 MHz and 12 MHz and I2C prescaler and clock divider registers are configured appropriately |                 | 400            | kHz     |
| $V_{il}$   | Low level input voltage   |   |                 | $0.3 V_{DDIO}$ | V       |
| $V_{ih}$   | High level input voltage  |   | $0.7 V_{DDIO}$  |                | V       |
| $V_{hys}$  | Input hysteresis  |   | $0.05 V_{DDIO}$ |                | V       |
| $V_{ol}$   | Low level output voltage  | 3 mA sink current   | 0               | 0.4            | V       |
| $t_{LOW}$  | Low period of SCL clock   | I2C clock module frequency is between 7 MHz and 12 MHz and I2C prescaler and clock divider registers are configured appropriately | 1.3             |                | $\mu$ s |
| $t_{HIGH}$ | High period of SCL clock  | I2C clock module frequency is between 7 MHz and 12 MHz and I2C prescaler and clock divider registers are configured appropriately | 0.6             |                | $\mu$ s |
| $I_i$      | Input current with an input voltage between $0.1 V_{DDIO}$ and $0.9 V_{DDIO}$ MAX |   | -10             | 10             | $\mu$ A |

### 5.11.4 Cortex-M3 Controller Area Network

#### NOTE

The CAN module uses the popular IP known as D\_CAN. This document uses the names “CAN” and “D\_CAN” interchangeably to reference this peripheral.

This device has two Cortex-M3 CAN peripherals. CAN is a serial communications protocol that efficiently supports distributed real-time control with a high level of security. The CAN module supports bit rates up to 1 Mbit/s and is compliant with the ISO11898-1 (CAN 2.0B) protocol specification.

CAN implements the following features:

- CAN protocol version 2.0 part A, B
- Bit rates up to 1 Mbit/s
- Multiple clock sources
- 32 message objects
- Individual identifier mask for each message object
- Programmable FIFO mode for message objects
- Programmable loop-back modes for self-test operation
- Suspend mode for debug support
- Software module reset
- Automatic bus on after Bus-Off state by a programmable 32-bit timer
- Message RAM parity check mechanism
- Two interrupt lines
- Global power down and wakeup support

[Figure 5-34](#) shows the Cortex-M3 CAN peripheral.

#### 5.11.4.1 Functional Overview

CAN performs CAN protocol communication according to ISO 11898-1 (identical to Bosch® CAN protocol specification 2.0 A, B). The bit rate can be programmed to values up to 1 Mbit/s. Additional transceiver hardware is required for the connection to the physical layer (CAN bus).

For communication on a CAN network, individual message objects can be configured. The message objects and identifier masks are stored in the Message RAM. All functions concerning the handling of messages are implemented in the message handler. Those functions are: acceptance filtering, the transfer of messages between the CAN Core and the Message RAM, and the handling of transmission requests.

The register set of the CAN is accessible directly by the CPU through the module interface. These registers are used to control/configure the CAN Core and the message handler, and to access the message RAM.

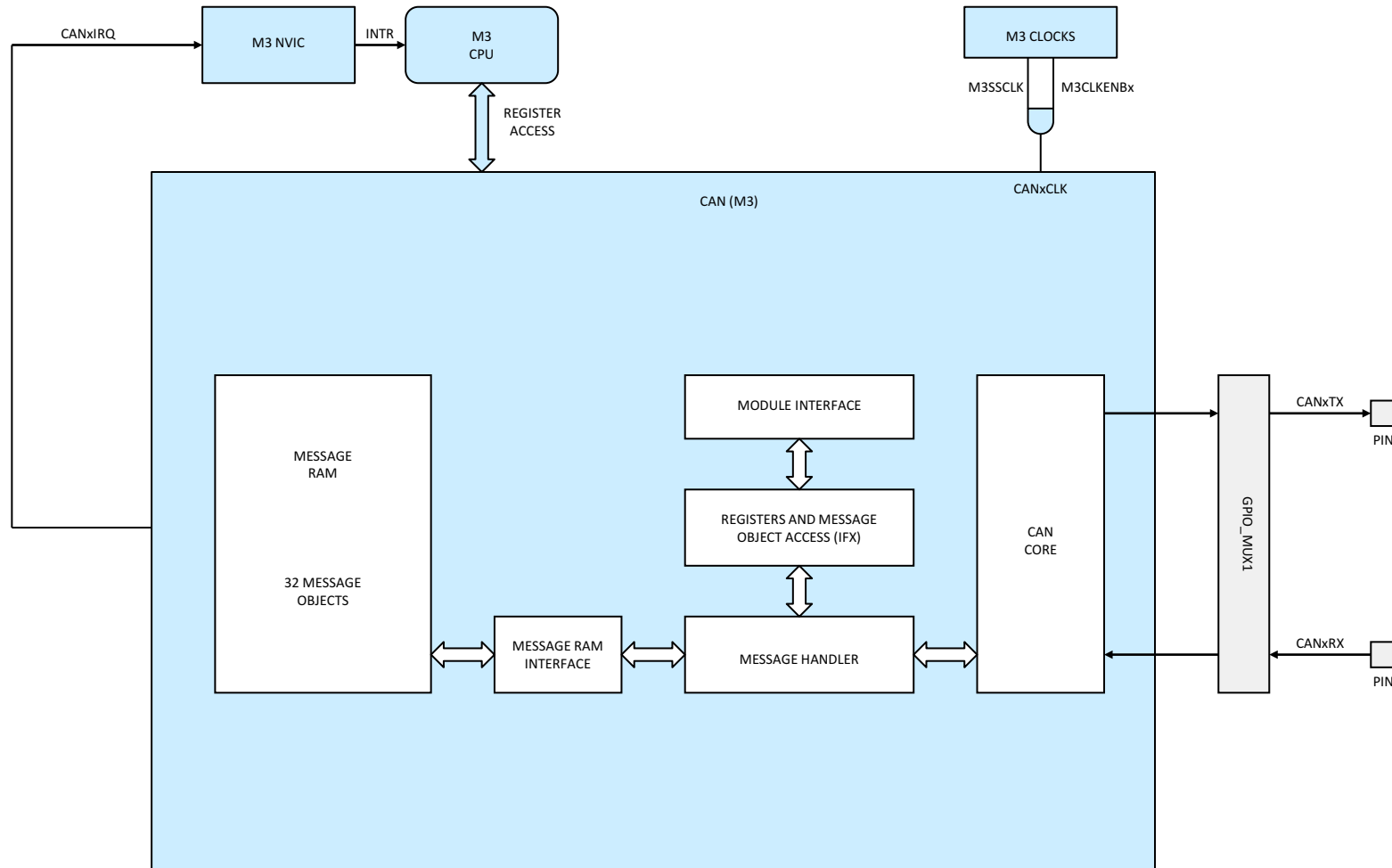

Figure 5-34. CAN (Cortex-M3)

### 5.11.5 Cortex-M3 Universal Serial Bus Controller

This device has one Cortex-M3 USB controller. The USB controller operates as a full-speed or low-speed function controller during point-to-point communications with the USB Host, Device, or OTG functions. The controller complies with the USB 2.0 standard, which includes SUSPEND and RESUME signaling. Thirty-two endpoints, which comprised of 2 hardwired endpoints for control transfers (one endpoint for IN and one endpoint for OUT) and 30 endpoints defined by firmware, along with a dynamic sizable FIFO, support multiple packet queuing. DMA access to the FIFO allows minimal interference from system software. Software-controlled connect and disconnect allow flexibility during USB device start-up. The controller complies with the Session Request Protocol (SRP) and Host Negotiation Protocol (HNP) of the OTG standard.

The USB controller includes the following features:

- Complies with USB-IF certification standards
- USB 2.0 full-speed (12-Mbps) and low-speed (1.5-Mbps) operation
- Integrated PHY
- Four transfer types: Control, Interrupt, Bulk, and Isochronous
- 32 endpoints:
  - One dedicated control IN endpoint and one dedicated control OUT endpoint
  - 15 configurable IN endpoints and 15 configurable OUT endpoints
- 4KB dedicated endpoint memory: one endpoint may be defined for double-buffered 1023-byte isochronous packet size
- VBUS droop and valid ID detection and interrupt
- Efficient transfers using DMA:
  - Separate channels for transmit and receive for up to three IN endpoints and three OUT endpoints
  - Channel requests asserted when FIFO contains required amount of data
- Electrical specifications are compliant with the USB Specification Rev. 2.0 (full-speed and low-speed support) and the On-The-Go Supplement to the USB 2.0 Specification Rev. 1.0. Some components of the USB system are integrated within the Concerto microcontroller and are specific to its design.

Figure 5-35 shows the USB peripheral.

#### 5.11.5.1 Functional Description

The USB controller provides full OTG negotiation by supporting both the SRP and the HNP. The SRP allows devices on the B side of a cable to request the A-side devices' turn on VBUS. The HNP is used after the initial session request protocol has powered the bus and provides a method to determine which end of the cable will act as the Host controller. When the device is connected to non-OTG peripherals or devices, the controller can detect which cable end was used and provides a register to indicate if the controller should act as the Host controller or the Device controller. This indication and the mode of operation are handled automatically by the USB controller. This autodetection allows the system to use a single A/B connector instead of having both A and B connectors in the system, and supports full OTG negotiations with other OTG devices.

In addition, the USB controller provides support for connecting to non-OTG peripherals or Host controllers. The USB controller can be configured to act as either a dedicated Host or Device, in which case, the USB0VBUS and USB0ID signals can be used as GPIOs. However, when the USB controller is acting as a self-powered Device, a GPIO input must be connected to VBUS and configured to generate an interrupt when the VBUS level drops. This interrupt is used to disable the pullup resistor on the USB0DP signal.

#### NOTE

When the USB is used, the system clock frequency (SYSCLK) must be at least 20 MHz.

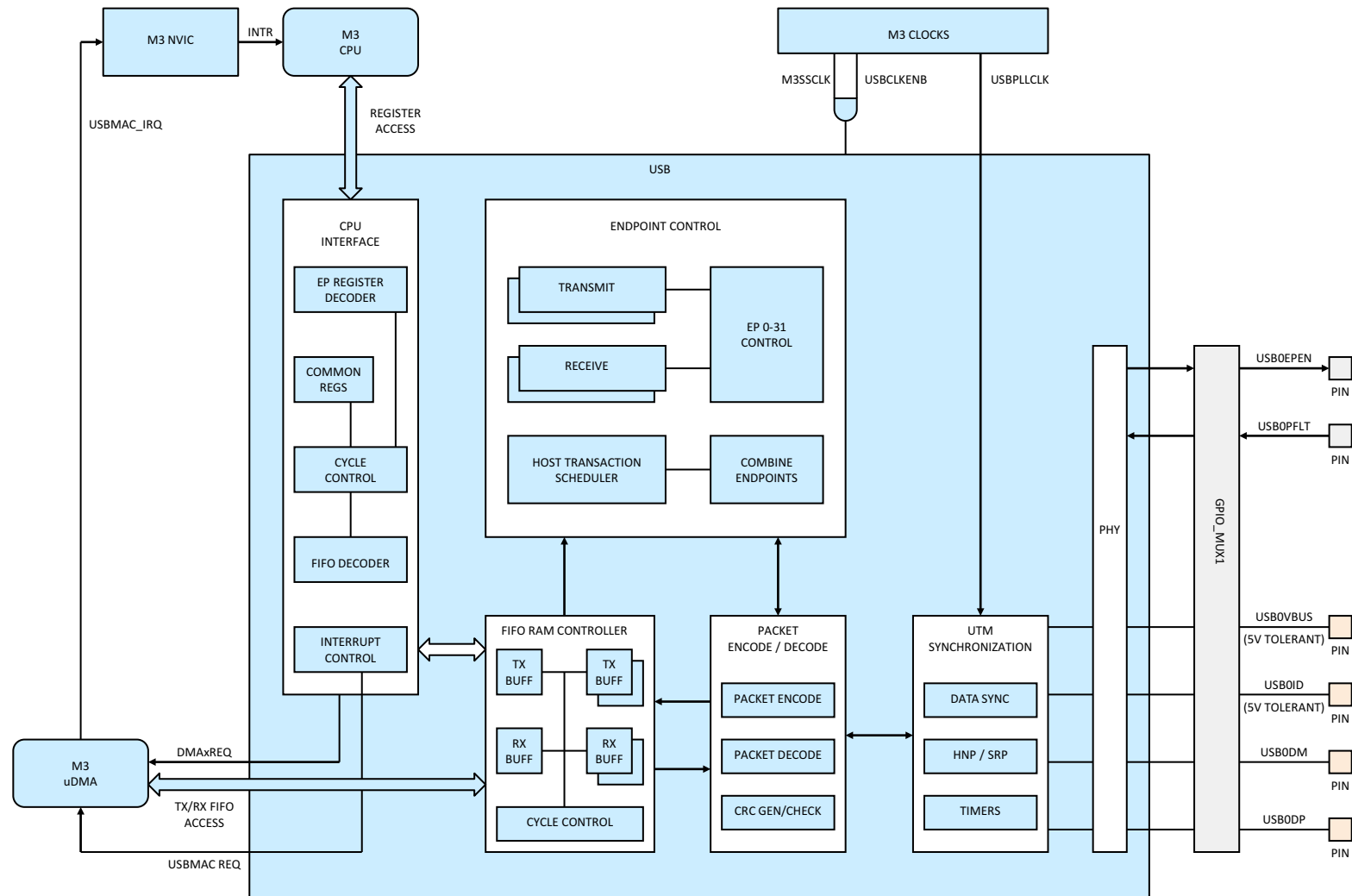

**Figure 5-35. USB**

### 5.11.6 Cortex-M3 Ethernet Media Access Controller

The Cortex-M3 EMAC conforms to IEEE 802.3 specifications and fully supports 10BASE-T and 100BASE-TX standards. This device has one Ethernet Media Access Controller.

The EMAC module has the following features:

- Conforms to the IEEE 802.3-2002 specification
  - 10BASE-T/100BASE-TX IEEE-802.3 compliant
- Multiple operational modes
  - Full- and half-duplex 100-Mbps
  - Full- and half-duplex 10-Mbps
  - Power-saving and power-down modes
- Highly configurable:
  - Programmable MAC address
  - Promiscuous mode support
  - CRC error-rejection control
  - User-configurable interrupts
- IEEE 1588 Precision Time Protocol: Provides highly accurate time stamps for individual packets
- Efficient transfers using the Micro Direct Memory Access Controller ( $\mu$ DMA)
  - Separate channels for transmit and receive
  - Receive channel request asserted on packet receipt
  - Transmit channel request asserted on empty transmit FIFO

Figure 5-36 shows the EMAC peripheral.

#### 5.11.6.1 Functional Overview

The Ethernet Controller is functionally divided into two layers: the Media Access Controller (MAC) layer and the Network Physical (PHY) layer. The MAC resides inside the device, and the PHY outside of the device. These layers correspond to the OSI model layers 2 and 1, respectively. The CPU accesses the Ethernet Controller through the MAC layer. The MAC layer provides transmit and receive processing for Ethernet frames. The MAC layer also provides the interface to the external PHY layer through an internal Media Independent Interface (MII). The PHY layer communicates with the Ethernet bus.

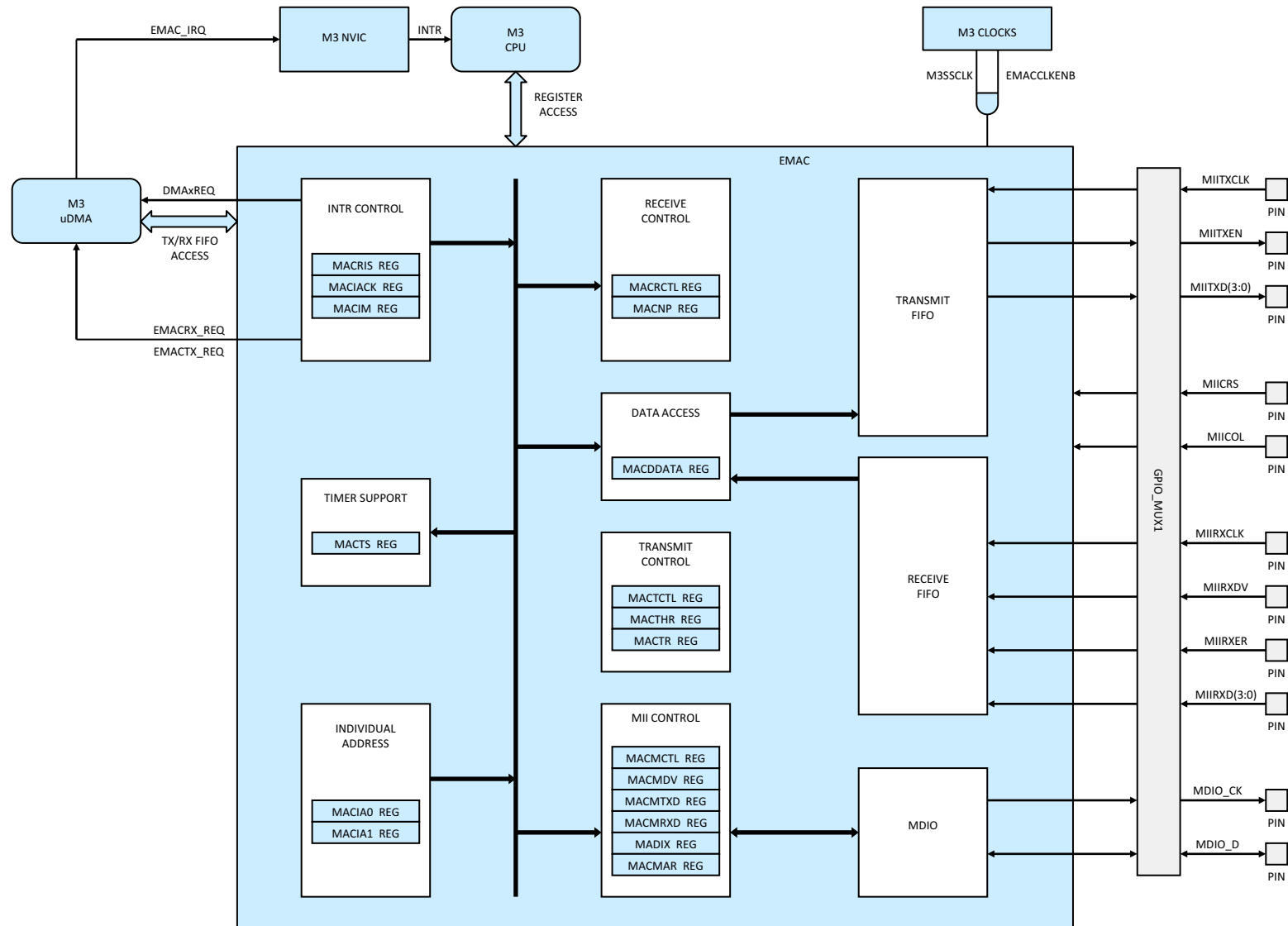

Figure 5-36. EMAC

### 5.11.6.2 MII Signals

The individual EMAC and Management Data Input/Output (MDIO) signals for the MII interface are summarized in [Table 5-60](#).

**Table 5-60. EMAC and MDIO Signals for MII Interface**

| SIGNAL      | TYPE <sup>(1)</sup> | DESCRIPTION   |
|-------------|---------------------|---|
| MIITXCK     | I                   | Transmit clock. The transmit clock is a continuous clock that provides the timing reference for transmit operations. The MIITXD and MIITXEN signals are tied to this clock. The clock is generated by the PHY and is 2.5 MHz at 10-Mbps operation and 25 MHz at 100-Mbps operation.   |
| MIITXER     | O                   | This pin is always driven <b>low</b> from the MAC controller on the device.   |
| MIITXD[3-0] | O                   | Transmit data. The transmit data pins are a collection of four data signals comprising 4 bits of data. MTDX0 is the least-significant bit (LSB). The signals are synchronized by MIITXCLK and are valid only when MIITXEN is asserted.  |
| MIITXEN     | O                   | Transmit enable. The transmit enable signal indicates that the MIITXD pins are generating nibble data for use by the PHY. MIITXEN is driven synchronously to MIITXCLK.  |
| MIICOL      | I                   | Collision detected. In half-duplex operation, the MIICOL pin is asserted by the PHY when the PHY detects a collision on the network. The MIICOL pin remains asserted while the collision condition persists. This signal is not necessarily synchronous to MIITXCLK or MIIRXCLK. In full-duplex operation, the MIICOL pin is used for hardware transmit flow control. Asserting the MIICOL pin will stop packet transmissions; packets in the process of being transmitted when MIICOL is asserted will complete transmission. The MIICOL pin should be held low if hardware transmit flow control is not used. |
| MIICRS      | I                   | Carrier sense. In half-duplex operation, the MIICRS pin is asserted by the PHY when the network is not idle in either transmit or receive. The pin is deasserted when both transmit and receive are idle. This signal is not necessarily synchronous to MIITXCLK or MIIRXCLK. In full-duplex operation, the MIICRS pin should be held low.  |
| MIIRXCK     | I                   | Receive clock. The receive clock is a continuous clock that provides the timing reference for receive operations. The MIIRXD, MIIRXDV, and MIIRXER signals are tied to this clock. The clock is generated by the PHY and is 2.5 MHz at 10-Mbps operation and 25 MHz at 100-Mbps operation.  |
| MIIRXD[3-0] | I                   | Receive data. The receive data pins are a collection of four data signals comprising 4 bits of data. MRDX0 is the least-significant bit. The signals are synchronized by MIIRXCLK and are valid only when MIIRXDV is asserted.  |
| MIIRXDV     | I                   | Receive data valid. The receive data valid signal indicates that the MIIRXD pins are generating nibble data for use by the EMAC. MIIRXDV is driven synchronously to MIIRXCLK.   |
| MIIRXER     | I                   | Receive error. The receive error signal is asserted for one or more MIIRXCLK periods to indicate that an error was detected in the received frame. The MIIRXER signal being asserted is meaningful only during data reception when MIIRXDV is active.   |
| MDIO_CK     | O                   | Management data clock. The MDIO data clock is sourced by the MDIO module on the system. MDIO_CK is used to synchronize MDIO data access operations done on the MDIO pin. The frequency of this clock is controlled by the CLKDIV bits in the MDIO Control Register (CONTROL).   |
| MDIO_D      | I/O                 | Management data input output. The MDIO data pin drives PHY management data into and out of the PHY by way of an access frame that consists of start-of-frame, read/write indication, PHY address, register address, and data bit cycles. The MDIO_D pin acts as an output for all but the data bit cycles, at which time the pin is an input for read operations.   |

(1) I = Input, O = Output, I/O = Input/Output

5.11.6.3 EMAC Electrical Data and Timing

Table 5-61. Timing Requirements for MIITXCK (see Figure 5-37)

| NO. |                |                               | 100 Mbps |     | 10 Mbps |     | UNIT |
|-----|----------------|-------------------------------|----------|-----|---------|-----|------|
|     |                |                               | MIN      | MAX | MIN     | MAX |      |
| 1   | $t_{c(TXCK)}$  | Cycle time, MIITXCK (25 MHz)  | 40       | 40  |         |     | ns   |
|     |                | Cycle time, MIITXCK (2.5 MHz) |          |     | 400     | 400 |      |
| 2   | $t_{w(TXCKH)}$ | Pulse duration, MIITXCK high  | 16       | 24  | 196     | 204 | ns   |
| 3   | $t_{w(TXCKL)}$ | Pulse duration, MIITXCK low   | 16       | 24  | 196     | 204 | ns   |

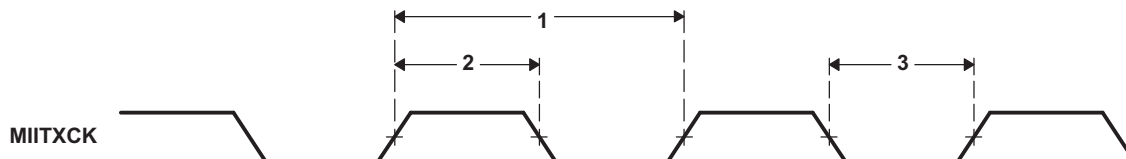

Figure 5-37. 100/10Mb/s MII Transmit Clock Timing

Table 5-62. Timing Requirements for MIIRXCK (see Figure 5-38)

| NO. |                |                               | 100 Mbps |     | 10 Mbps |     | UNIT |
|-----|----------------|-------------------------------|----------|-----|---------|-----|------|
|     |                |                               | MIN      | MAX | MIN     | MAX |      |
| 1   | $t_{c(RXCK)}$  | Cycle time, MIIRXCK (25 MHz)  | 40       | 40  |         |     | ns   |
|     |                | Cycle time, MIIRXCK (2.5 MHz) |          |     | 400     | 400 |      |
| 2   | $t_{w(RXCKH)}$ | Pulse duration, MIIRXCK high  | 16       | 24  | 196     | 204 | ns   |
| 3   | $t_{w(RXCKL)}$ | Pulse duration, MIIRXCK low   | 16       | 24  | 196     | 204 | ns   |

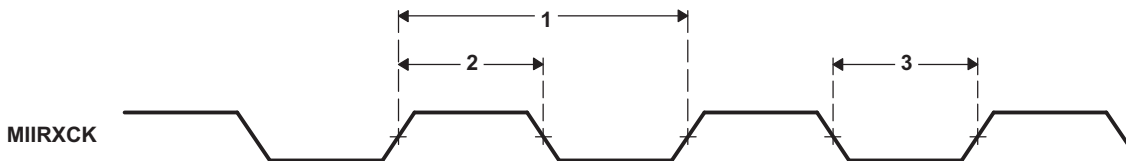
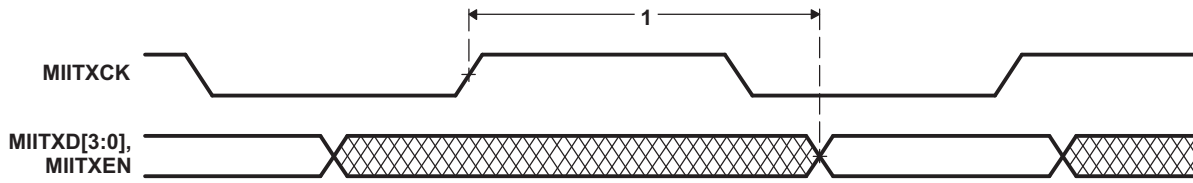

Figure 5-38. 100/10Mb/s MII Receive Clock Timing

**Table 5-63. Switching Characteristics Over Recommended Operating Conditions (Unless Otherwise Noted) for EMAC MII Transmit (see Figure 5-39)**

| NO. | PARAMETER  | MIN | MAX | UNIT |
|-----|--|-----|-----|------|
| 1   | $t_{d(TXCKH-MTXDV)}$ Delay time, MIITXCK high to transmit selected signals valid | 5   | 25  | ns   |



**Figure 5-39. 100/10Mb/s MII Transmit Timing**

**Table 5-64. Timing Requirements for EMAC MII Receive (see Figure 5-40)**

| NO. | PARAMETER  | MIN | NOM | MAX | UNIT |
|-----|--|-----|-----|-----|------|
| 1   | $t_{su(MRXDV-RXCKH)}$ Setup time, receive selected signals valid before MIIRXCK high |     | 8   |     | ns   |
| 2   | $t_{h(RXCKH-MRXDV)}$ Hold time, receive selected signals valid after MIIRXCK high    |     | 7   |     | ns   |

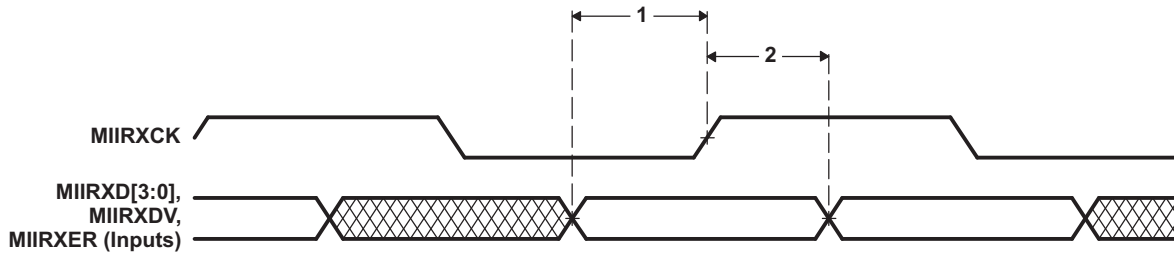

**Figure 5-40. 100/10Mb/s MII Receive Timing**

5.11.6.4 MDIO Electrical Data and Timing

**Table 5-65. Switching Characteristics Over Recommended Operating Conditions (Unless Otherwise Noted) for MDIO\_CK (see Figure 5-41)**

| NO. | PARAMETER     |                               | MIN | MAX | UNIT |
|-----|---------------|-------------------------------|-----|-----|------|
| 1   | $t_{c(MCK)}$  | Cycle time, MDIO_CK (2.5 MHz) | 400 | 400 | ns   |
| 2   | $t_{w(MCKH)}$ | Pulse duration, MDIO_CK high  | 196 | 204 | ns   |
| 3   | $t_{w(MCKL)}$ | Pulse duration, MDIO_CK low   | 196 | 204 | ns   |

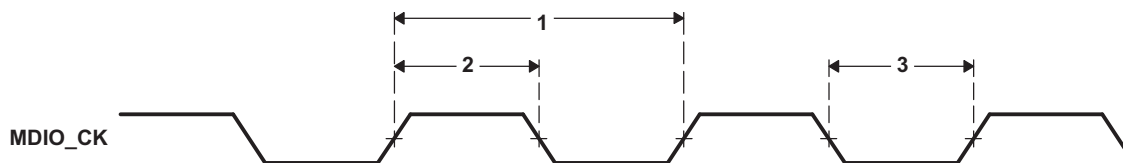

Figure 5-41. MII Serial Management Timing

**Table 5-66. Switching Characteristics Over Recommended Operating Conditions (Unless Otherwise Noted) for MDIO as Output (see Figure 5-42)**

| NO. | PARAMETER         |  | MIN | MAX | UNIT |
|-----|-------------------|--|-----|-----|------|
| 1   | $t_{d(MCKH-MDV)}$ | Delay time, MDIO_CK high to MDIO_D valid | 5   | 25  | ns   |

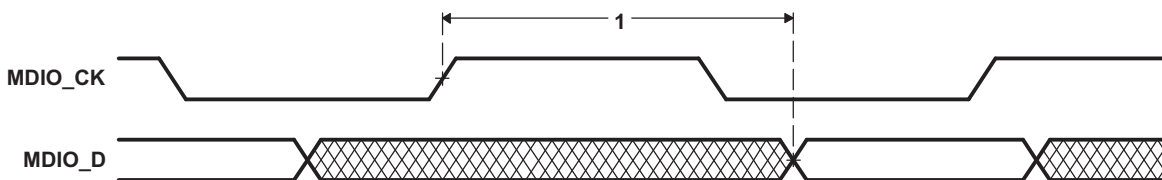

Figure 5-42. MII Serial Management Timing – MDIO as Output

**Table 5-67. Timing Requirements for MDIO as Input (see Figure 5-43)**

| NO. | PARAMETER          |  | MIN | NOM | MAX | UNIT |
|-----|--------------------|--|-----|-----|-----|------|
| 4   | $t_{su(MDV-MCKH)}$ | Setup time, MDIO_D valid before MDIO_CK high |     | 20  |     | ns   |
| 5   | $t_{h(MCKH-MDV)}$  | Hold time, MDIO_D valid after MDIO_CK high   |     | 7   |     | ns   |

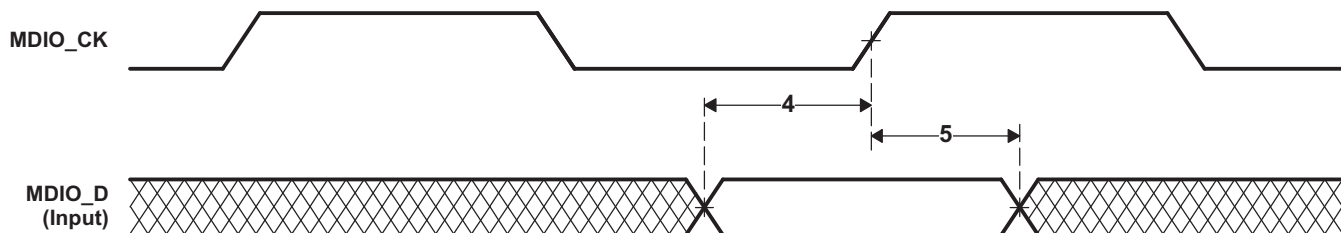

Figure 5-43. MII Serial Management Timing – MDIO as Input

## 5.12 Control Subsystem Peripherals

Control Subsystem peripherals are accessible from the C28x CPU through the C28x Memory Bus, and from the C28x DMA through the C28x DMA Bus. They include one NMI Watchdog, three Timers, four Serial Port Peripherals (SCI, SPI, McBSP, I2C), and three types of Control Peripherals (ePWM, eQEP, eCAP). Additionally, the C28x CPU/DMA also have access to the EPI, and to Analog and Shared peripherals (see [Section 5.10](#)).

For detailed information on the processor peripherals, see the [Concerto F28M35x Technical Reference Manual](#).

### 5.12.1 High-Resolution PWM and Enhanced PWM Modules

There are nine PWM modules in the Concerto device. Eight of these are of the HRPWM type with high-resolution control on both A and B signal outputs, and one is of the ePWM type. The HRPWM modules have all the features of the ePWM plus they offer significantly higher PWM resolution (time granularity on the order of 150 ps). [Figure 5-44](#) shows the eight HRPWM modules (PWM 1–8) and one ePWM module (PWM 9).

The synchronization inputs to the PWM modules include the SYNCI signal from the GPTRIP1 output of GPIO\_MUX1, and the TBCLKSYNC signal from the CPCLKCR0 register. Synchronization output SYNCO1 comes from the ePWM1 module and is stretched by 8 HSPCLK cycles before entering GPIO\_MUX1. There are two groups of trip signal inputs to PWM modules. TRIP1–15 inputs come from GPTRIP1–12 (from GPIO\_MUX1), ECCDBLERR signal (from C28x Local and Shared RAM), and PIEERR signal from the C28x CPU. TZ1–6 (Trip Zone) inputs come from GPTRIP 1–3 (from GPIO\_MUX1), EQEPERR (from the eQEP peripheral), CLOCKFAIL (from M3 CLOCKS), and EMUSTOP (from the C28x CPU).

There are 9 SOCA PWM outputs and 9 SOCB PWM outputs—a pair from each PWM module. The 9 SOCA outputs are OR-ed together and stretched by 32 HSPCLK cycles before entering GPIO\_MUX1 as a single SOCAO signal. The 9 SOCB outputs are OR-ed together and stretched by 32 HSPCLK cycles before entering GPIO\_MUX1 as a single SOCBO signal. The 18 SOCA/B outputs from PWM1–PWM9 also go to the Analog Subsystem, where they can be selected to become conversion triggers to ADC modules.

The nine PWM modules also drive two other sets of outputs which can interrupt the C28x CPU through the C28x PIE block. These are nine EPWMINT interrupts and nine EPWMTZINT trip-zone interrupts. See [Figure 5-45](#) for the internal structure of the HRPWM and ePWM modules. The green-colored blocks are common to both ePWM and HRPWM modules, but only the HRPWMs have the grey-colored hi-resolution blocks.

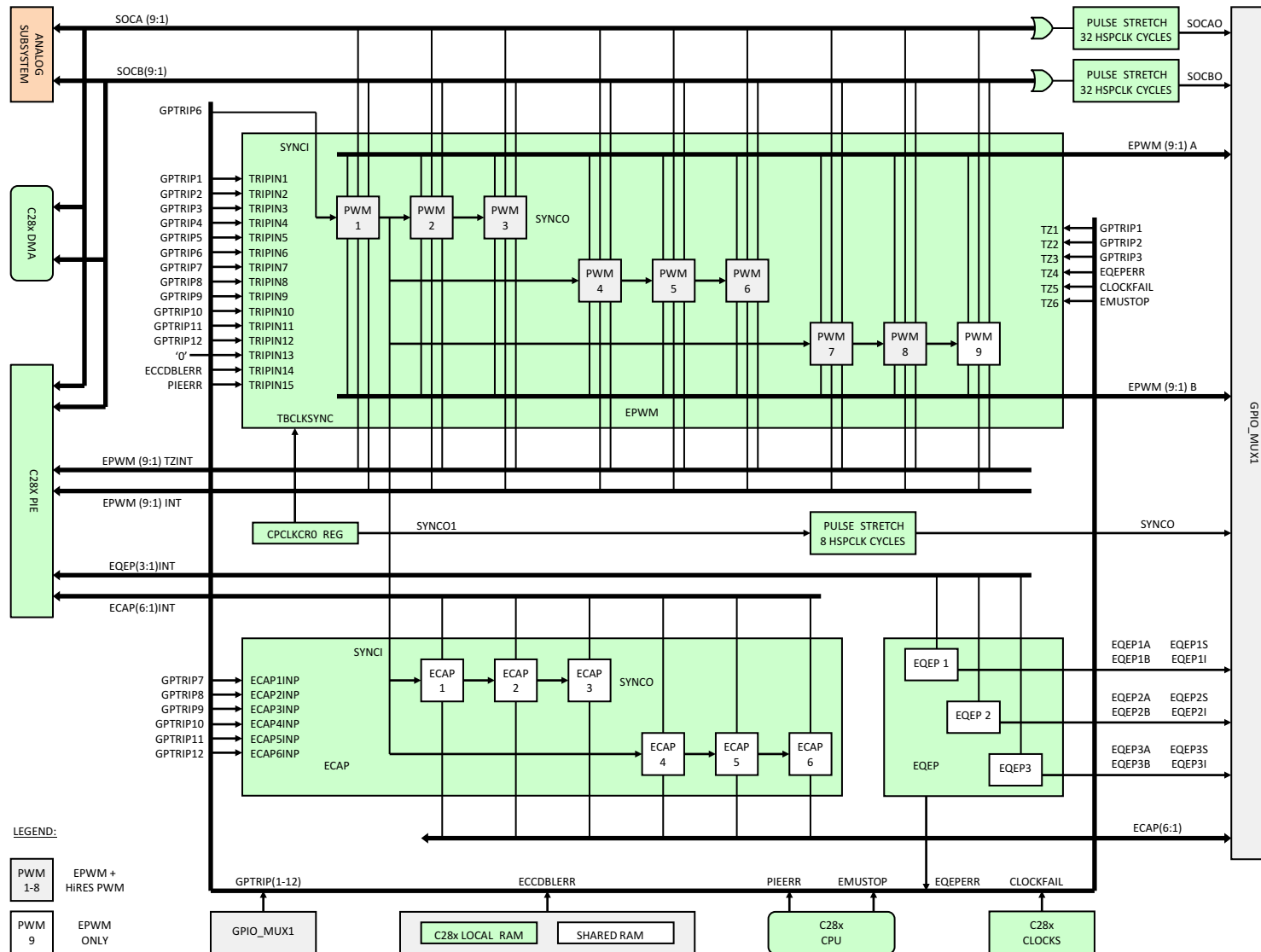

Copyright © 2017, Texas Instruments Incorporated

Figure 5-44. PWM, eCAP, eQEP

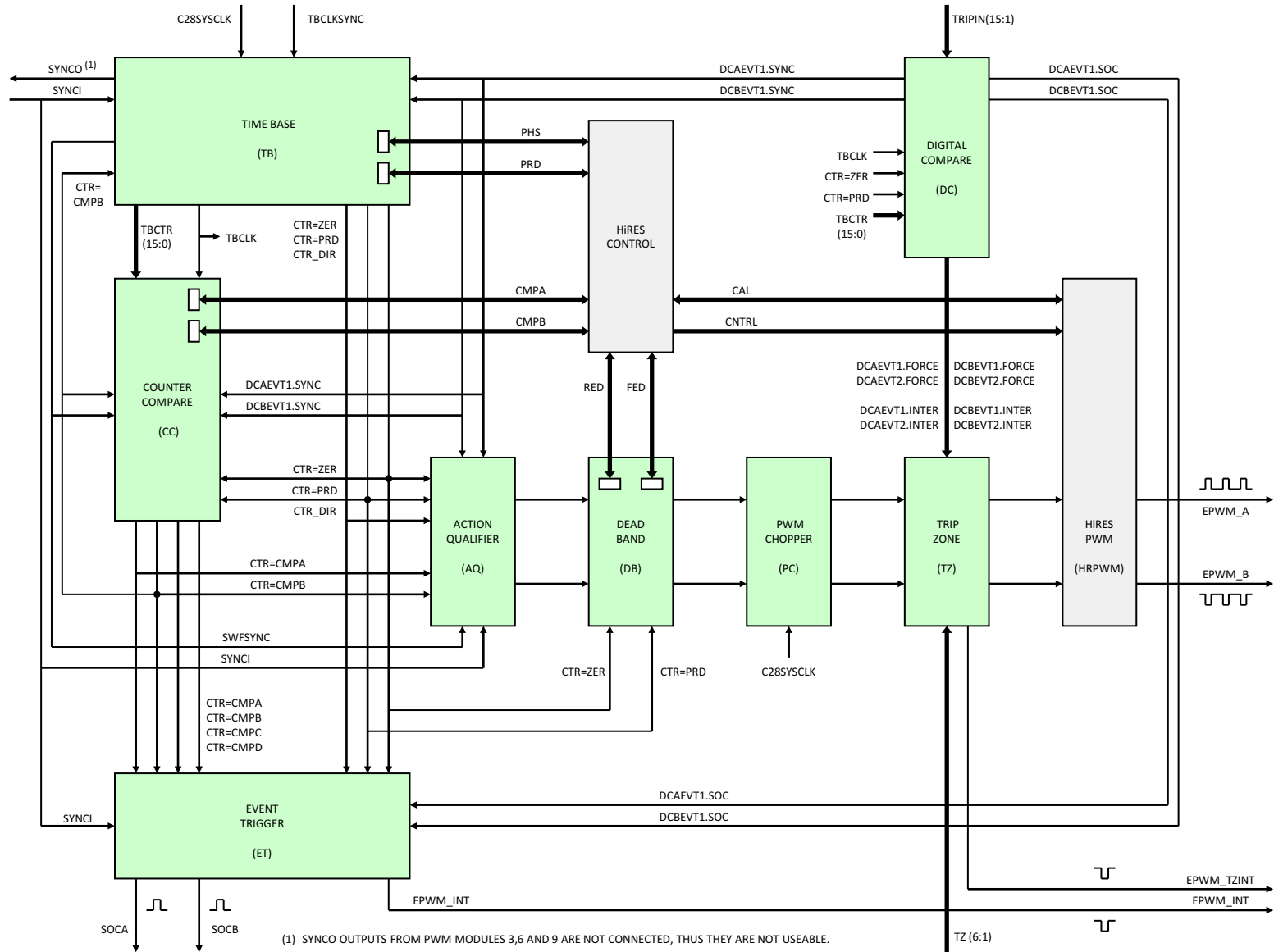

Copyright © 2017, Texas Instruments Incorporated

Figure 5-45. Internal Structure of PWM

### 5.12.1.1 HRPWM Electrical Data and Timing

Table 5-68 shows the high-resolution PWM switching characteristics.

**Table 5-68. High-Resolution PWM Characteristics at SYSCLKOUT = (60–150 MHz)**

| PARAMETER   | MIN | TYP | MAX | UNIT |
|---|-----|-----|-----|------|
| Micro Edge Positioning (MEP) step size <sup>(1)</sup> |     | 150 | 310 | ps   |

(1) The MEP step size will be largest at high temperature and minimum voltage on V<sub>DD</sub>. MEP step size will increase with higher temperature and lower voltage and decrease with lower temperature and higher voltage. Applications that use the HRPWM feature should use MEP Scale Factor Optimizer (SFO) estimation software functions. See the TI software libraries for details of using SFO function in end applications. SFO functions help to estimate the number of MEP steps per SYSCLKOUT period dynamically while the HRPWM is in operation.

### 5.12.1.2 ePWM Electrical Data and Timing

Table 5-69 shows the PWM timing requirements and Table 5-70 shows the PWM switching characteristics.

**Table 5-69. ePWM Timing Requirements<sup>(1)</sup>**

|                        |                      | MIN   | MAX | UNIT   |
|------------------------|----------------------|---|-----|--------|
| t <sub>w</sub> (SYCIN) | Asynchronous         | 2t <sub>c</sub> (SCO)                         |     | cycles |
|                        | Synchronous          | 2t <sub>c</sub> (SCO)                         |     | cycles |
|                        | With input qualifier | 1t <sub>c</sub> (SCO) + t <sub>w</sub> (IQSW) |     | cycles |

(1) For an explanation of the input qualifier parameters, see Table 5-29.

**Table 5-70. ePWM Switching Characteristics**

over recommended operating conditions (unless otherwise noted)

| PARAMETER                           | TEST CONDITIONS   | MIN                   | MAX | UNIT   |
|-------------------------------------|---|-----------------------|-----|--------|
| t <sub>w</sub> (PWM)                | Pulse duration, PWMx output high/low  | 20                    |     | ns     |
| t <sub>w</sub> (SYNCOUT)            | Sync output pulse width   | 8t <sub>c</sub> (SCO) |     | cycles |
| t <sub>d</sub> (PWM)t <sub>za</sub> | Delay time, trip input active to PWM forced high<br>Delay time, trip input active to PWM forced low |                       | 25  | ns     |
| t <sub>d</sub> (TZ-PWM)HZ           | Delay time, trip input active to PWM Hi-Z   |                       | 20  | ns     |

5.12.1.2.1 Trip-Zone Input Timing

Table 5-71. Trip-Zone Input Timing Requirements<sup>(1)</sup>

|             |  | MIN                         | MAX | UNIT   |
|-------------|--|-----------------------------|-----|--------|
| $t_{w(TZ)}$ | Pulse duration, $\overline{TZx}$ input low |                             |     |        |
|             | Asynchronous                               | $1t_{c(SCO)}$               |     | cycles |
|             | Synchronous                                | $2t_{c(SCO)}$               |     | cycles |
|             | With input qualifier                       | $1t_{c(SCO)} + t_{w(IQSW)}$ |     | cycles |

(1) For an explanation of the input qualifier parameters, see Table 5-29.

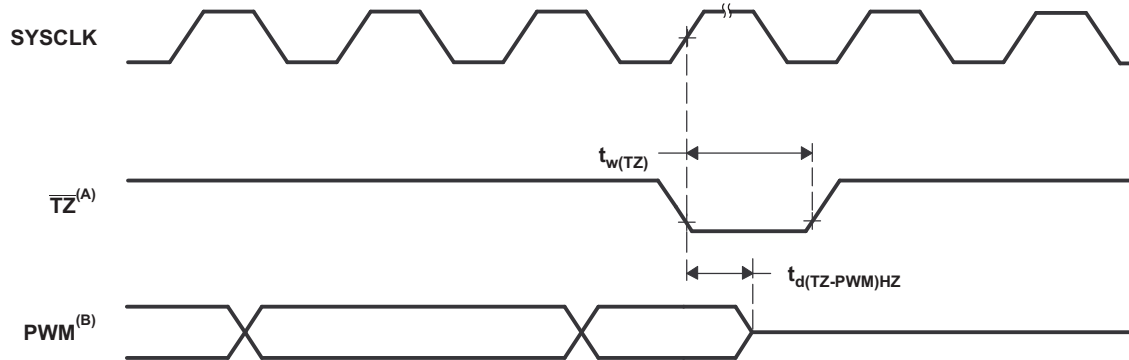

- A.  $\overline{TZ}$  -  $\overline{TZ1}$ ,  $\overline{TZ2}$ ,  $\overline{TZ3}$ ,  $\overline{TZ4}$ ,  $\overline{TZ5}$ ,  $\overline{TZ6}$
- B. PWM refers to all the PWM pins in the device. The state of the PWM pins after  $\overline{TZ}$  is taken high depends on the PWM recovery software.

Figure 5-46. PWM Hi-Z Characteristics

## 5.12.2 Enhanced Capture Module

There are six identical eCAP modules in Concerto devices: eCAP1, 2, 3, 4, 5, and 6. Each eCAP module represents one complete capture channel. Its main function is to accurately capture the timings of external events. One can also use eCAP modules for PWM, when they are not being used for input captures. This secondary function is selected by flipping the CAP/APWM bit of the ECCTL2 Register. For PWM function, the counter operates in count-up mode, providing a time base for asymmetrical pulse width (PWM) waveforms. The CAP1 and CAP2 registers become the period and compare registers, respectively; while the CAP3 and CAP4 registers become the shadow registers of the main period and capture registers, respectively.

The left side of [Figure 5-47](#) shows internal components associated with the capture block, and the right side depicts the PWM block. The two blocks share a set of four registers that are used in both Capture and PWM modes. Other components include the Counter block that uses the SYNCIN and SYNCOUT ports to synchronize with other modules; and the Interrupt Trigger and Flag Control block that sends Capture, PWM, and Counter events to the C28x PIE block through the ECAPxINT output. There are six ECAPxINT interrupts—one for each eCAP module.

The eCAP peripherals are clocked by C28SYSCLK, and its registers are accessible by the C28x CPU. This peripheral clock can be enabled or disabled by flipping a bit in one of the system control registers.

### 5.12.2.1 eCAP Electrical Data and Timing

[Table 5-72](#) shows the eCAP timing requirement and [Table 5-73](#) shows the eCAP switching characteristics.

**Table 5-72. eCAP Timing Requirement<sup>(1)</sup>**

|              |                           | MIN                         | MAX | UNIT   |
|--------------|---------------------------|-----------------------------|-----|--------|
| $t_{w(CAP)}$ | Capture input pulse width |                             |     |        |
|              | Asynchronous              | $2t_{c(SCO)}$               |     | cycles |
|              | Synchronous               | $2t_{c(SCO)}$               |     | cycles |
|              | With input qualifier      | $1t_{c(SCO)} + t_{w(IQSW)}$ |     | cycles |

(1) For an explanation of the input qualifier parameters, see [Table 5-29](#).

**Table 5-73. eCAP Switching Characteristics**

over recommended operating conditions (unless otherwise noted)

| PARAMETER     | TEST CONDITIONS                       | MIN | MAX | UNIT |
|---------------|---------------------------------------|-----|-----|------|
| $t_{w(APWM)}$ | Pulse duration, APWMx output high/low | 20  |     | ns   |

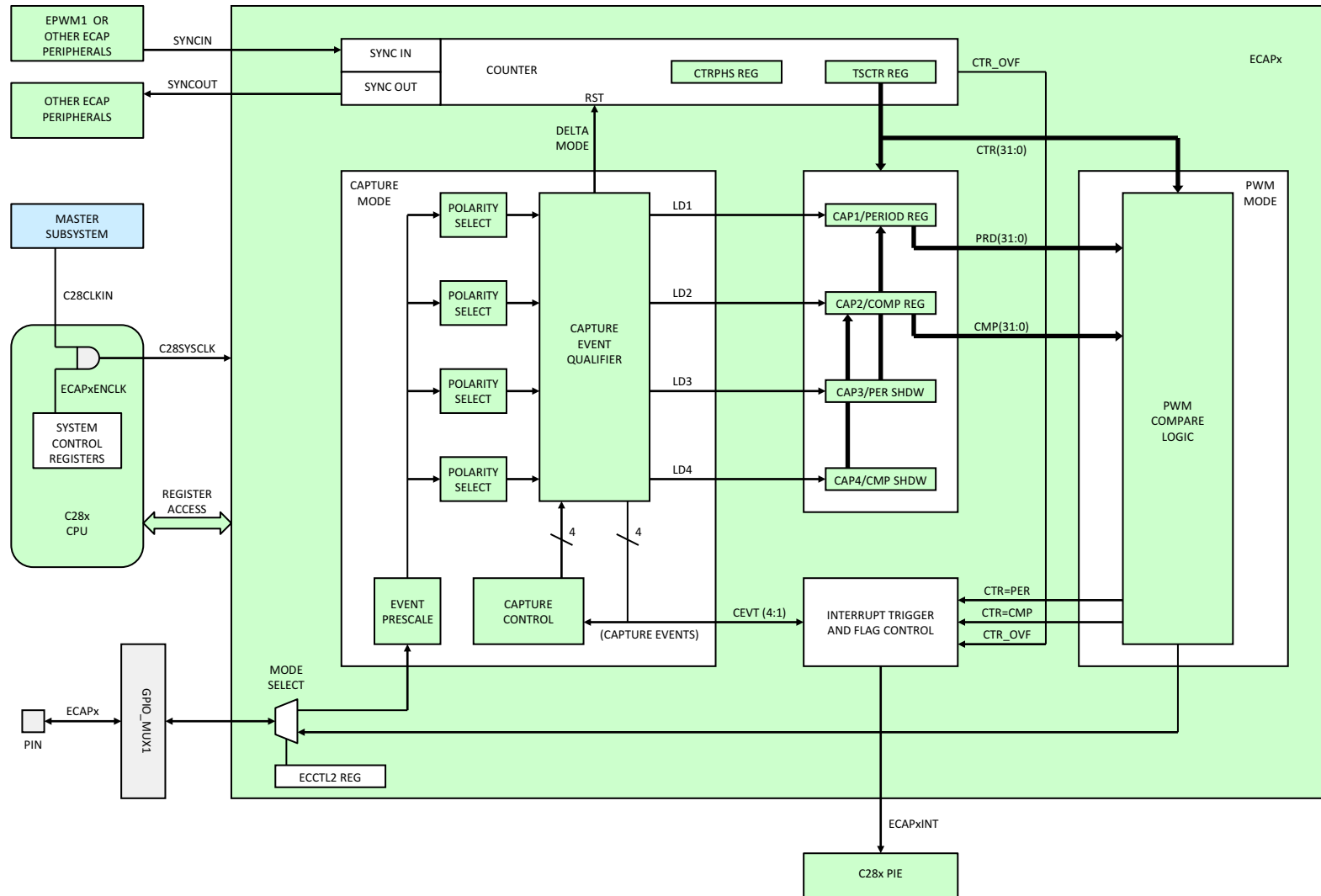

Copyright © 2017, Texas Instruments Incorporated

Figure 5-47. eCAP

### 5.12.3 Enhanced Quadrature Encoder Pulse Module

The eQEP module interfaces directly with linear or rotary incremental encoders to obtain position, direction, and speed information from rotating machines used in high-performance motion and position-control systems. There are three Type 0 eQEP modules in each Concerto device.

Each eQEP peripheral comprises five major functional blocks: Quadrature Capture Unit (QCAP), Position Counter/Control Unit (PCCU), Quadrature Decoder (QDU), Unit Time Base for speed and frequency measurement (UTIME), and Watchdog timer for detecting stalls (QWDOG). The C28x CPU controls and communicates with these modules through a set of associated registers (see [Figure 5-48](#)). The eQEP peripherals are clocked by C28SYSCLK, and its registers are accessible by the C28x CPU. This peripheral clock can be enabled or disabled by flipping a bit in one of the system control registers.

Each eQEP peripheral connects through the GPIO\_MUX1 block to four device pins. Two of the four pins are always inputs, while the other two can be inputs or outputs, depending on the operating mode. The PCCU block of each eQEP also drives one interrupt to the C28x PIE. There is a total of three EQEPxINT interrupts—one from each of the three eQEP modules.

#### 5.12.3.1 eQEP Electrical Data and Timing

[Table 5-74](#) shows the eQEP timing requirement and [Table 5-75](#) shows the eQEP switching characteristics.

**Table 5-74. eQEP Timing Requirements<sup>(1)</sup>**

|                        |                           |  | MIN   | MAX | UNIT   |
|------------------------|---------------------------|--|---|-----|--------|
| t <sub>w(QEPP)</sub>   | QEP input period          | Asynchronous <sup>(2)</sup> /synchronous | 2t <sub>c(SCO)</sub>                            |     | cycles |
|                        |                           | With input qualifier                     | 2[1t <sub>c(SCO)</sub> + t <sub>w(IQSW)</sub> ] |     | cycles |
| t <sub>w(INDEXH)</sub> | QEP Index Input High time | Asynchronous <sup>(2)</sup> /synchronous | 2t <sub>c(SCO)</sub>                            |     | cycles |
|                        |                           | With input qualifier                     | 2t <sub>c(SCO)</sub> + t <sub>w(IQSW)</sub>     |     | cycles |
| t <sub>w(INDEXL)</sub> | QEP Index Input Low time  | Asynchronous <sup>(2)</sup> /synchronous | 2t <sub>c(SCO)</sub>                            |     | cycles |
|                        |                           | With input qualifier                     | 2t <sub>c(SCO)</sub> + t <sub>w(IQSW)</sub>     |     | cycles |
| t <sub>w(STROBH)</sub> | QEP Strobe High time      | Asynchronous <sup>(2)</sup> /synchronous | 2t <sub>c(SCO)</sub>                            |     | cycles |
|                        |                           | With input qualifier                     | 2t <sub>c(SCO)</sub> + t <sub>w(IQSW)</sub>     |     | cycles |
| t <sub>w(STROBL)</sub> | QEP Strobe Input Low time | Asynchronous <sup>(2)</sup> /synchronous | 2t <sub>c(SCO)</sub>                            |     | cycles |
|                        |                           | With input qualifier                     | 2t <sub>c(SCO)</sub> + t <sub>w(IQSW)</sub>     |     | cycles |

(1) For an explanation of the input qualifier parameters, see [Table 5-29](#).

(2) Refer to the [F28M35x Concerto™ MCUs Silicon Errata](#) for limitations in the asynchronous mode.

**Table 5-75. eQEP Switching Characteristics**

over recommended operating conditions (unless otherwise noted)

| PARAMETER                  |  | TEST CONDITIONS | MIN | MAX                  | UNIT   |
|----------------------------|--|-----------------|-----|----------------------|--------|
| t <sub>d(CNTR)xin</sub>    | Delay time, external clock to counter increment            |                 |     | 4t <sub>c(SCO)</sub> | cycles |
| t <sub>d(PCS-OUT)QEP</sub> | Delay time, QEP input edge to position compare sync output |                 |     | 6t <sub>c(SCO)</sub> | cycles |

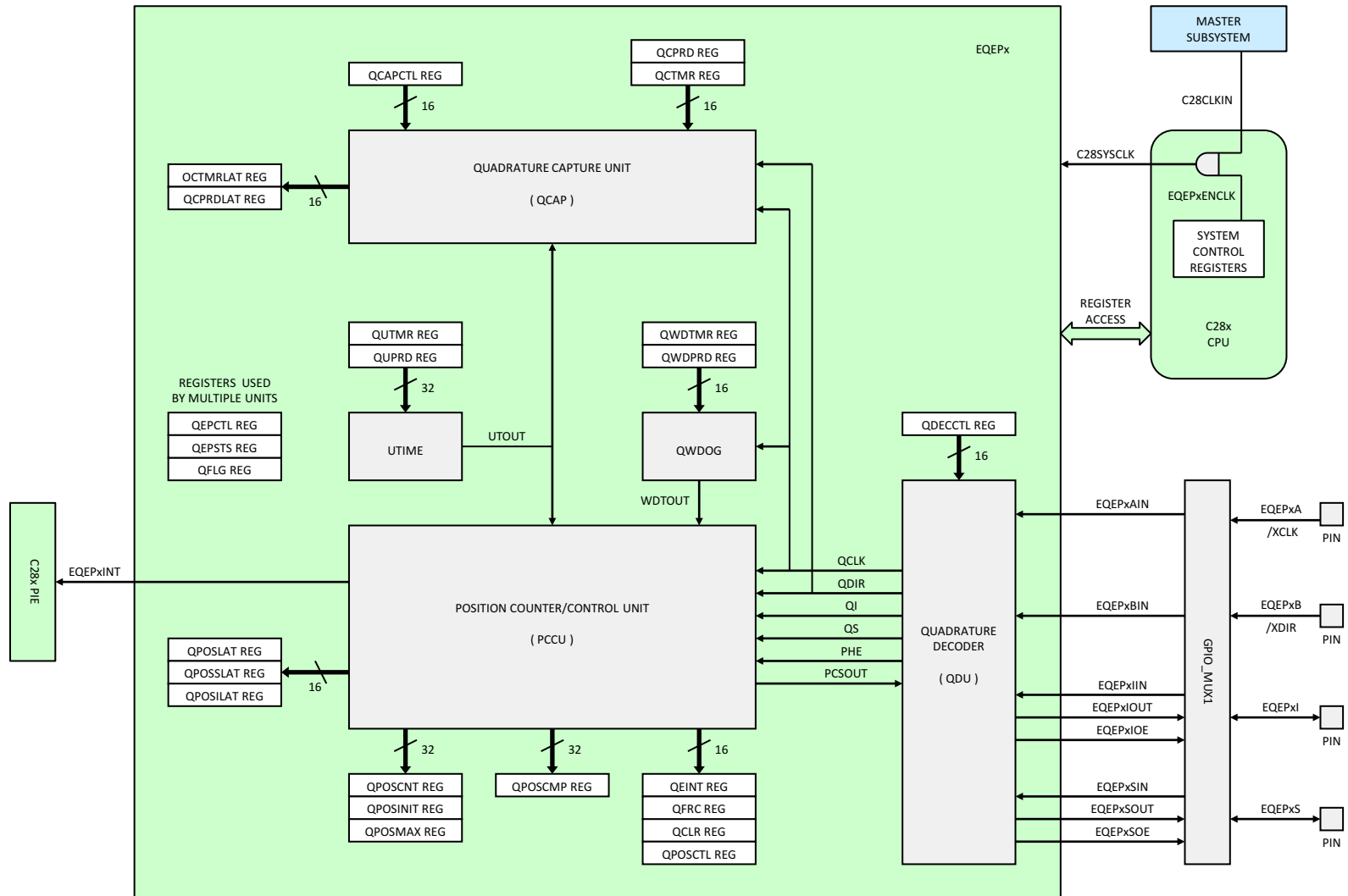

Copyright © 2017, Texas Instruments Incorporated

Figure 5-48. eQEP

### 5.12.4 C28x Inter-Integrated Circuit Module

This device has one C28x I2C peripheral. The I2C provides an interface between a Concerto device and devices compliant with the NXP® *I<sup>2</sup>C-bus specification and user manual* (UM10204) and connected by way of an I2C bus. External components attached to this 2-wire serial bus can transmit 1-bit to 8-bit data to and receive 1-bit to 8-bit data from the device through the I2C module.

#### NOTE

A unit of data transmitted or received by the I2C module can have fewer than 8 bits; however, for convenience, a unit of data is called a **data byte** in this section. The number of bits in a data byte is selectable through the BC bits of the mode register, I2CMR.

The I2C module has the following features:

- Compliance with the NXP *I<sup>2</sup>C-bus specification and user manual* (UM10204):
  - Support for 1-bit to 8-bit format transfers
  - 7-bit and 10-bit addressing modes
  - General call
  - START byte mode
  - Support for multiple master-transmitters and slave-receivers
  - Support for multiple slave-transmitters and master-receivers
  - Combined master transmit-and-receive and receive-and-transmit mode
  - Data transfer rate of from 10 Kbps up to 400 Kbps (I2C Fast-mode rate)
- One 4-word receive FIFO and one 4-word transmit FIFO
- One interrupt that can be used by the CPU. This interrupt can be generated as a result of one of the following conditions:
  - Transmit-data ready
  - Receive-data ready
  - Register-access ready
  - No-acknowledgment received
  - Arbitration lost
  - Stop condition detected
  - Addressed as slave
- An additional interrupt that can be used by the CPU when in FIFO mode
- Module enable or disable capability
- Free data format mode

The I2C module does not support:

- High-speed mode (Hs-mode)
- CBUS-compatibility mode

Figure 5-49 shows the C28x I2C peripheral.

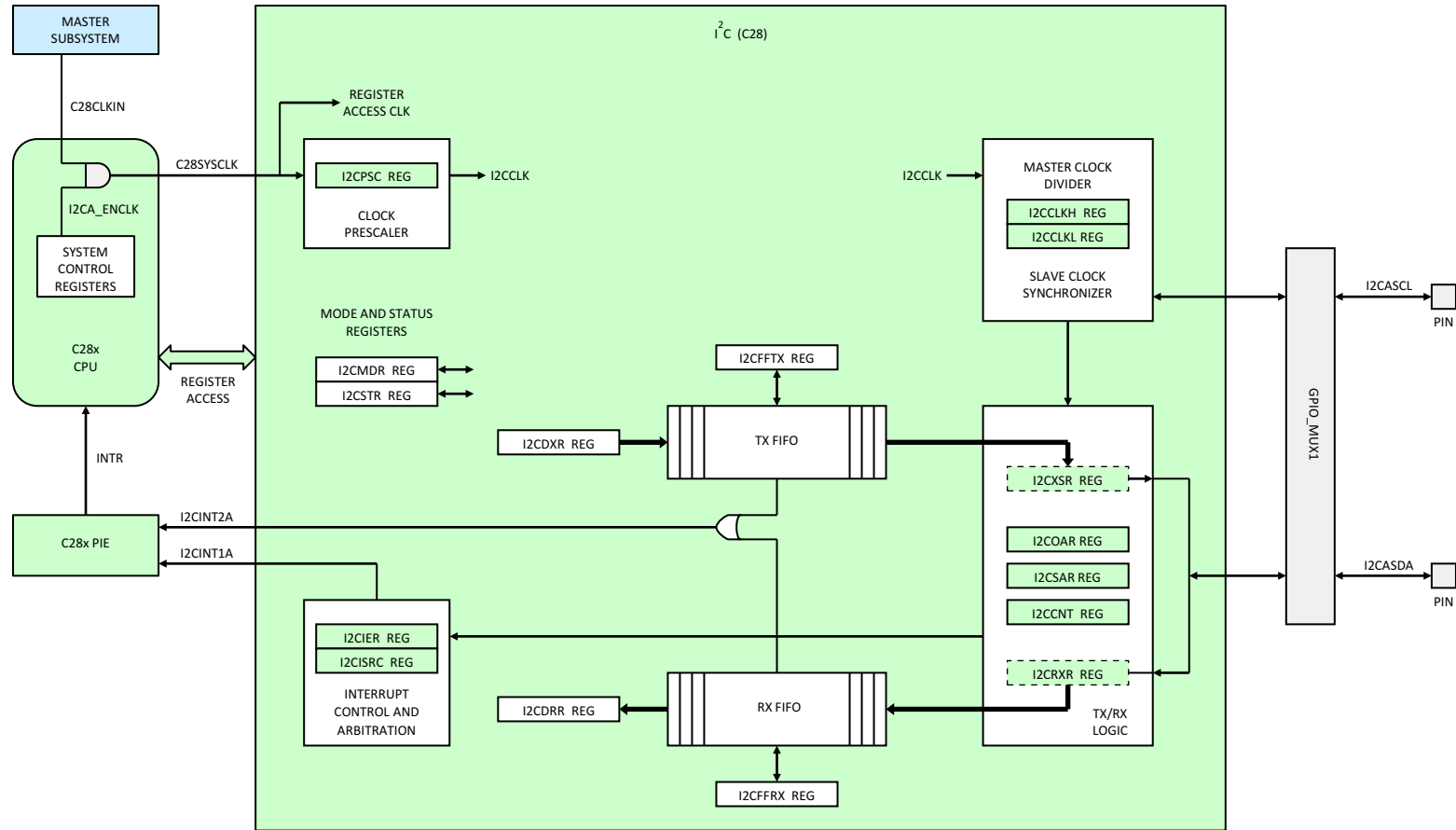

Figure 5-49. I2C (C28x)

### 5.12.4.1 Functional Overview

Each device connected to an I2C Bus is recognized by a unique address. Each device can operate as either a transmitter or a receiver, depending on the function of the device. A device connected to the I2C Bus can also be considered as the master or the slave when performing data transfers. A master device is the device that initiates a data transfer on the bus and generates the clock signals to permit that transfer. During this transfer, any device addressed by this master is considered a slave. The I2C module supports the multi-master mode, in which one or more devices capable of controlling an I2C Bus can be connected to the same I2C Bus.

For data communication, the I2C module has a serial data pin (SDA) and a serial clock pin (SCL). These two pins carry information between the C28x device and other devices connected to the I2C Bus. The SDA and SCL pins both are bidirectional. They each must be connected to a positive supply voltage using a pullup resistor. When the bus is free, both pins are high. The driver of these two pins has an open-drain configuration to perform the required wired-AND function. There are two major transfer techniques:

1. Standard Mode: Send exactly  $n$  data values, where  $n$  is a value you program in an I2C module register.
2. Repeat Mode: Keep sending data values until you use software to initiate a STOP condition or a new START condition.

The I2C module consists of the following primary blocks:

- A serial interface: one data pin (SDA) and one clock pin (SCL)
- Data registers and FIFOs to temporarily hold receive data and transmit data traveling between the SDA pin and the CPU
- Control and status registers
- A peripheral bus interface to enable the CPU to access the I2C module registers and FIFOs.

### 5.12.4.2 Clock Generation

The device clock generator receives a signal from an external clock source and produces an I2C input clock with a programmed frequency. The I2C input clock is equivalent to the CPU clock and is then divided twice more inside the I2C module to produce the module clock and the master clock.

### 5.12.4.3 I2C Electrical Data and Timing

**Table 5-76. I2C Timing**

|            |   | TEST CONDITIONS   | MIN             | MAX            | UNIT    |
|------------|---|---|-----------------|----------------|---------|
| $f_{SCL}$  | SCL clock frequency   | I2C clock module frequency is between 7 MHz and 12 MHz and I2C prescaler and clock divider registers are configured appropriately |                 | 400            | kHz     |
| $V_{il}$   | Low level input voltage   |   |                 | $0.3 V_{DDIO}$ | V       |
| $V_{ih}$   | High level input voltage  |   | $0.7 V_{DDIO}$  |                | V       |
| $V_{hys}$  | Input hysteresis  |   | $0.05 V_{DDIO}$ |                | V       |
| $V_{ol}$   | Low level output voltage  | 3 mA sink current   | 0               | 0.4            | V       |
| $t_{LOW}$  | Low period of SCL clock   | I2C clock module frequency is between 7 MHz and 12 MHz and I2C prescaler and clock divider registers are configured appropriately | 1.3             |                | $\mu$ s |
| $t_{HIGH}$ | High period of SCL clock  | I2C clock module frequency is between 7 MHz and 12 MHz and I2C prescaler and clock divider registers are configured appropriately | 0.6             |                | $\mu$ s |
| $I_i$      | Input current with an input voltage between $0.1 V_{DDIO}$ and $0.9 V_{DDIO}$ MAX |   | -10             | 10             | $\mu$ A |

### 5.12.5 C28x Serial Communications Interface

This device has one SCI peripheral. SCI is a two-wire asynchronous serial port, commonly known as a UART. The SCI module supports digital communications between the CPU and other asynchronous peripherals that use the standard non-return-to-zero (NRZ) format

The SCI receiver and transmitter each have a 16-level-deep FIFO for reducing servicing overhead, and each has its own separate enable and interrupt bits. Both can be operated independently for half-duplex communication, or simultaneously for full-duplex communication. To specify data integrity, the SCI checks received data for break detection, parity, overrun, and framing errors. The bit rate is programmable to different speeds through a 16-bit baud-select register.

Features of the SCI module include:

- Two external pins:
  - SCITXD: SCI transmit-output pin
  - SCIRXD: SCI receive-input pin
  - NOTE:** Both pins can be used as GPIO if not used for SCI.
  - Baud rate programmable to 64K different rates
- Data-word format
  - One start bit
  - Data-word length programmable from 1 to 8 bits
  - Optional even/odd/no parity bit
  - One or two stop bits
- Four error-detection flags: parity, overrun, framing, and break detection
- Two wake-up multiprocessor modes: idle-line and address bit
- Half- or full-duplex operation
- Double-buffered receive and transmit functions
- Transmitter and receiver operations can be accomplished through interrupt-driven or polled algorithms with status flags.
  - Transmitter: TXRDY flag (transmitter-buffer register is ready to receive another character) and TX EMPTY flag (transmitter-shift register is empty)
  - Receiver: RXRDY flag (receiver-buffer register is ready to receive another character), BRKDT flag (break condition occurred), and RX ERROR flag (monitoring four interrupt conditions)
- Separate enable bits for transmitter and receiver interrupts (except BRKDT)
- NRZ format

---

#### NOTE

All registers in this module are 8-bit registers that are connected to Peripheral Frame 2. When a register is accessed, the register data is in the lower byte (bits 7–0), and the upper byte (bits 15–8) is read as zeros. Writing to the upper byte has no effect.

---

- Auto baud-detect hardware logic
- 16-level transmit and receive FIFO

Figure 5-50 shows the C28x SCI peripheral.

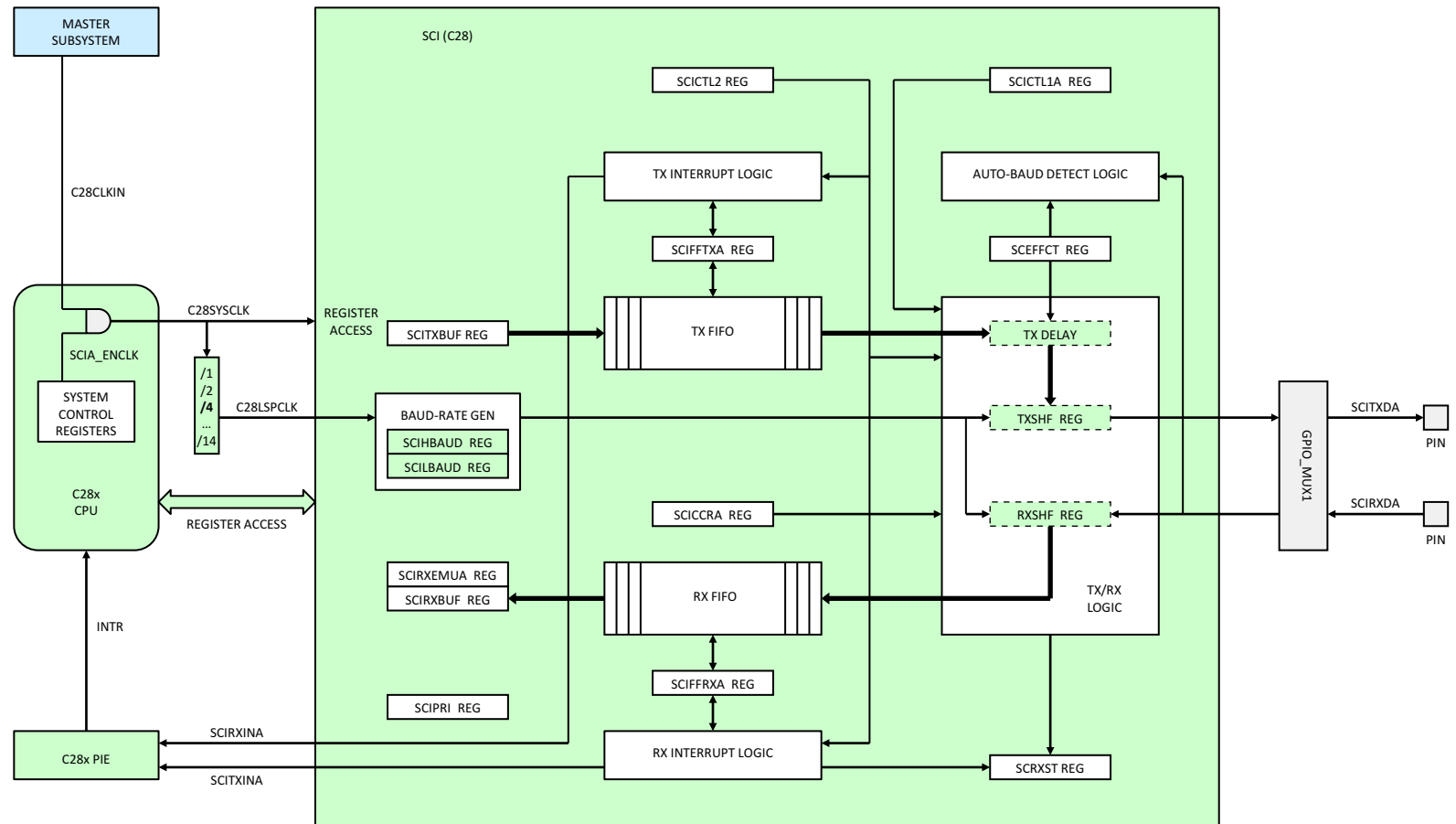

Figure 5-50. SCI (C28x)

### 5.12.5.1 Architecture

The major elements used in full-duplex operation include:

- A transmitter (TX) and its major registers:
  - SCITXBUF register – Transmitter Data Buffer register. Contains data (loaded by the CPU) to be transmitted
  - TXSHF register – Transmitter Shift register. Accepts data from the SCITXBUF register and shifts data onto the SCITXD pin, 1 bit at a time
- A receiver (RX) and its major registers:
  - RXSHF register – Receiver Shift register. Shifts data in from the SCIRXD pin, 1 bit at a time
  - SCIRXBUF register – Receiver Data Buffer register. Contains data to be read by the CPU. Data from a remote processor is loaded into the RXSHF register and then into the SCIRXBUF and SCIRXEMU registers
- A programmable baud generator
- Data-memory-mapped control and status registers enable the CPU to access the I2C module registers and FIFOs.

The SCI receiver and transmitter can operate either independently or simultaneously.

### 5.12.5.2 Multiprocessor and Asynchronous Communication Modes

The SCI has two multiprocessor protocols: the idle-line multiprocessor mode and the address-bit multiprocessor mode. These protocols allow efficient data transfer between multiple processors.

The SCI offers the UART communications mode for interfacing with many popular peripherals. The asynchronous mode requires two lines to interface with many standard devices such as terminals and printers that use RS-232-C formats.

Data transmission characteristics include:

- One start bit
- One to eight data bits
- An even/odd parity bit or no parity bit
- One or two stop bits with a programmed frequency

### 5.12.6 C28x Serial Peripheral Interface

This device has one C28x SPI. The SPI is a high-speed synchronous serial input/output (I/O) port that allows a serial bit stream of programmed length (1 to 16 bits) to be shifted into and out of the device at a programmed bit-transfer rate. The SPI is normally used for communications between the DSP controller and external peripherals or another controller. Typical applications include external I/O or peripheral expansion through devices such as shift registers, display drivers, and ADCs. Multi-device communications are supported by the master/slave operation of the SPI. The port supports a 16-level, receive-and-transmit FIFO for reducing CPU servicing overhead.

The SPI module features include:

- SPISOMI: SPI slave-output/master-input pin
  - SPISIMO: SPI slave-input/master-output pin
  - SPISTE: SPI slave transmit-enable pin
  - SPICLK: SPI serial-clock pin
- NOTE:** All four pins can be used as GPIO, if the SPI module is not used.
- Two operational modes: master and slave
  - Baud rate: 125 different programmable rates. The maximum baud rate that can be employed is limited by the maximum speed of the I/O buffers used on the SPI pins.
  - Data word length: 1 to 16 data bits
  - Four clocking schemes (controlled by clock polarity and clock phase bits) include:
    - Falling edge without phase delay: SPICLK active-high. SPI transmits data on the falling edge of the SPICLK signal and receives data on the rising edge of the SPICLK signal.
    - Falling edge with phase delay: SPICLK active-high. SPI transmits data one half-cycle ahead of the falling edge of the SPICLK signal and receives data on the falling edge of the SPICLK signal.
    - Rising edge without phase delay: SPICLK inactive-low. SPI transmits data on the rising edge of the SPICLK signal and receives data on the falling edge of the SPICLK signal.
    - Rising edge with phase delay: SPICLK inactive-low. SPI transmits data one half-cycle ahead of the rising edge of the SPICLK signal and receives data on the rising edge of the SPICLK signal.
  - Simultaneous receive-and-transmit operation (transmit function can be disabled in software)
  - Transmitter and receiver operations are accomplished through either interrupt-driven or polled algorithms.
  - Twelve SPI module control registers: Located in control register frame beginning at address 7040h.

#### NOTE

All registers in this module are 16-bit registers that are connected to Peripheral Frame 2. When a register is accessed, the register data is in the lower byte (bits 7–0), and the upper byte (bits 15–8) is read as zeros. Writing to the upper byte has no effect.

- 16-level transmit and receive FIFO
- Delayed transmit control

Figure 5-51 shows the C28x SPI peripheral.

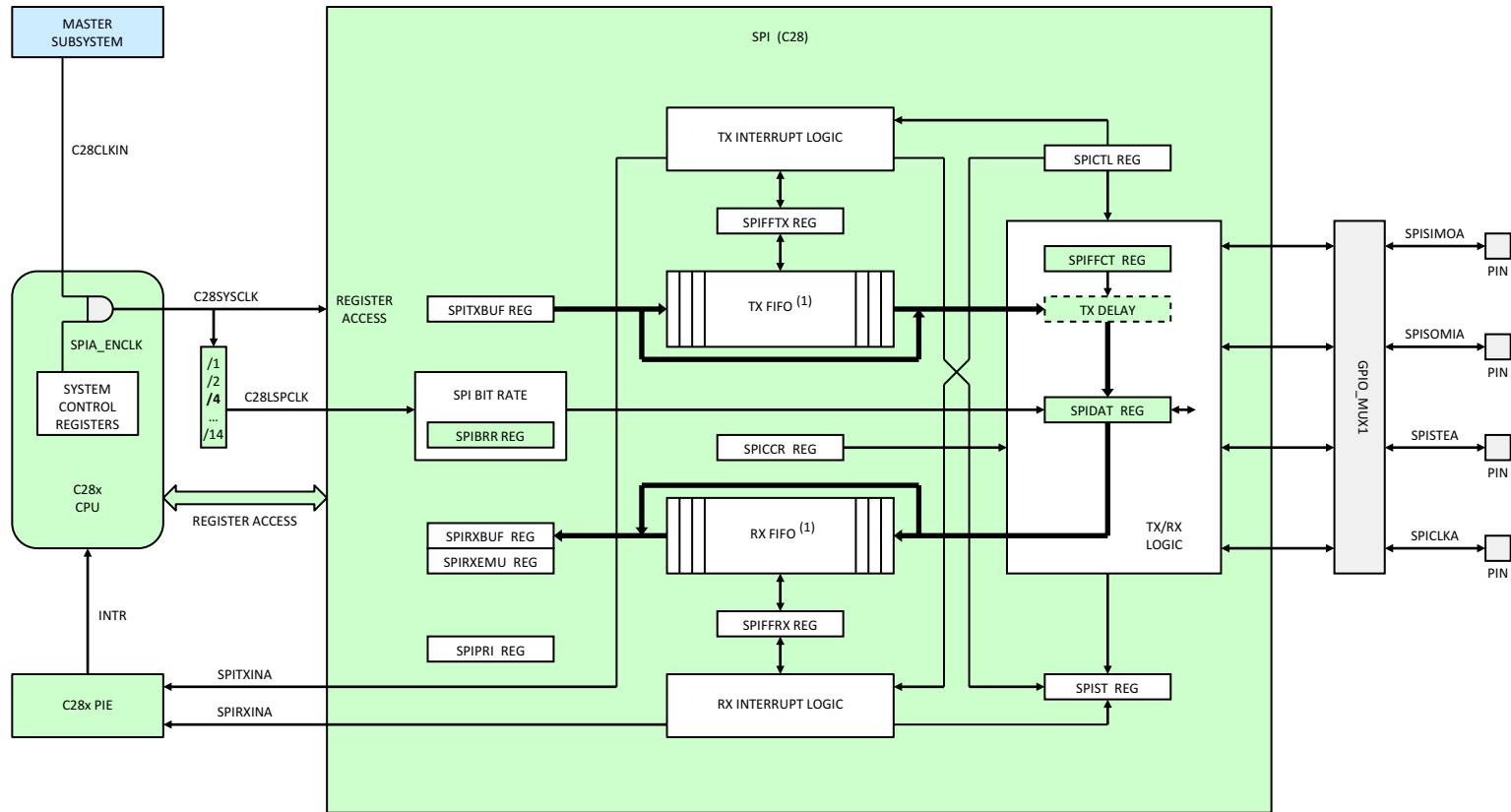

(1) RX FIFO AND TX FIFO CAN BE BYPASSED BY CONFIGURING BIT SPIFFENA OF THE SPIFFTX REGISTER

Figure 5-51. SPI (C28x)

### 5.12.6.1 Functional Overview

The SPI operates in master or slave mode. The master initiates data transfer by sending the SPICLK signal. For both the slave and the master, data is shifted out of the shift registers on one edge of the SPICLK and latched into the shift register on the opposite SPICLK clock edge. If the CLOCK PHASE bit (SPICTL.3) is high, data is transmitted and received a half-cycle before the SPICLK transition. As a result, both controllers send and receive data simultaneously. The application software determines whether the data is meaningful or dummy data. There are three possible methods for data transmission:

- Master sends data; slave sends dummy data
- Master sends data; slave sends data
- Master sends dummy data; slave sends data

The master can initiate a data transfer at any time because it controls the SPICLK signal. The software, however, determines how the master detects when the slave is ready to broadcast data.

## 5.12.6.2 SPI Electrical Data and Timing

This section contains both Master Mode and Slave Mode timing data.

### 5.12.6.2.1 Master Mode Timing

Table 5-77 lists the master mode timing (clock phase = 0) and Table 5-78 lists the master mode timing (clock phase = 1). Figure 5-52 and Figure 5-53 show the timing waveforms.

**Table 5-77. SPI Master Mode External Timing (Clock Phase = 0)<sup>(1)(2)(3)(4)(5)</sup>**

| NO. | PARAMETER  | BRR EVEN              |                       | BRR ODD                                  |  | UNIT |
|-----|--|-----------------------|-----------------------|--|--|------|
|     |  | MIN                   | MAX                   | MIN                                      | MAX                                      |      |
| 1   | $t_{c(SPC)M}$ Cycle time, SPICLK                                 | $4t_{c(LSPCLK)}$      | $128t_{c(LSPCLK)}$    | $5t_{c(LSPCLK)}$                         | $127t_{c(LSPCLK)}$                       | ns   |
| 2   | $t_{w(SPC1)M}$ Pulse duration, SPICLK first pulse                | $0.5t_{c(SPC)M} - 10$ | $0.5t_{c(SPC)M} + 10$ | $0.5t_{c(SPC)M} + 0.5t_{c(LSPCLK)} - 10$ | $0.5t_{c(SPC)M} + 0.5t_{c(LSPCLK)} + 10$ | ns   |
| 3   | $t_{w(SPC2)M}$ Pulse duration, SPICLK second pulse               | $0.5t_{c(SPC)M} - 10$ | $0.5t_{c(SPC)M} + 10$ | $0.5t_{c(SPC)M} - 0.5t_{c(LSPCLK)} - 10$ | $0.5t_{c(SPC)M} - 0.5t_{c(LSPCLK)} + 10$ | ns   |
| 4   | $t_{d(SIMO)M}$ Delay time, SPICLK to SPISIMO valid               |                       | 10                    |  | 10                                       | ns   |
| 5   | $t_{v(SIMO)M}$ Valid time, SPISIMO valid after SPICLK            | $0.5t_{c(SPC)M} - 10$ |                       | $0.5t_{c(SPC)M} - 0.5t_{c(LSPCLK)} - 10$ |  | ns   |
| 8   | $t_{su(SOMI)M}$ Setup time, SPISOMI before SPICLK                | 35                    |                       | 35                                       |  | ns   |
| 9   | $t_{h(SOMI)M}$ Hold time, SPISOMI valid after SPICLK             | 0                     |                       | 0  |  | ns   |
| 23  | $t_{d(SPC)M}$ Delay time, $\overline{SPISTE}$ active to SPICLK   | $t_{c(SPC)M} - 10$    |                       | $0.5t_{c(SPC)M} - 0.5t_{c(LSPCLK)} - 10$ |  | ns   |
| 24  | $t_{d(STE)M}$ Delay time, SPICLK to $\overline{SPISTE}$ inactive | $0.5t_{c(SPC)M} - 10$ |                       | $0.5t_{c(SPC)M} - 0.5t_{c(LSPCLK)} - 10$ |  | ns   |

(1) The MASTER / SLAVE bit (SPICTL.2) is set and the CLOCK PHASE bit (SPICTL.3) is cleared.

(2)  $t_{c(SPC)}$  = SPI clock cycle time = LSPCLK/4 or LSPCLK/(SPIBRR + 1)

(3)  $t_{c(LCO)}$  = LSPCLK cycle time

(4) Internal clock prescalers must be adjusted such that the SPI clock speed is limited to the following SPI clock rate:

Master mode transmit 25-MHz MAX, master mode receive 12.5-MHz MAX

Slave mode transmit 12.5-MHz MAX, slave mode receive 12.5-MHz MAX.

(5) The active edge of the SPICLK signal referenced is controlled by the clock polarity bit (SPICCR.6).

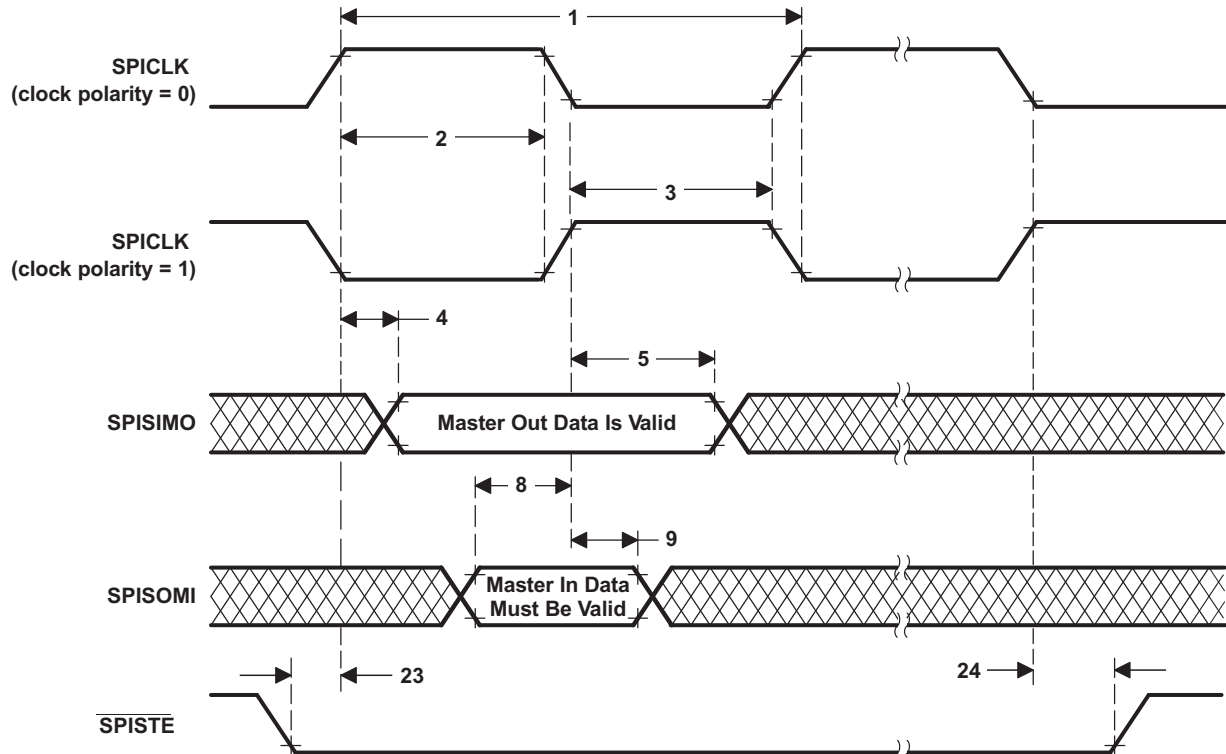

Figure 5-52. SPI Master Mode External Timing (Clock Phase = 0)

Table 5-78. SPI Master Mode External Timing (Clock Phase = 1)<sup>(1)(2)(3)(4)(5)</sup>

| NO. | PARAMETER   | BRR EVEN              |                       | BRR ODD                                  |  | UNIT |
|-----|---|-----------------------|-----------------------|--|--|------|
|     |   | MIN                   | MAX                   | MIN                                      | MAX                                      |      |
| 1   | $t_{c(SPC)M}$ Cycle time, SPICLK                                  | $4t_{c(LSPCLK)}$      | $128t_{c(LSPCLK)}$    | $5t_{c(LSPCLK)}$                         | $127t_{c(LSPCLK)}$                       | ns   |
| 2   | $t_{w(SPC1)M}$ Pulse duration, SPICLK first pulse                 | $0.5t_{c(SPC)M} - 10$ | $0.5t_{c(SPC)M} + 10$ | $0.5t_{c(SPC)M} - 0.5t_{c(LSPCLK)} - 10$ | $0.5t_{c(SPC)M} - 0.5t_{c(LSPCLK)} + 10$ | ns   |
| 3   | $t_{w(SPC2)M}$ Pulse duration, SPICLK second pulse                | $0.5t_{c(SPC)M} - 10$ | $0.5t_{c(SPC)M} + 10$ | $0.5t_{c(SPC)M} + 0.5t_{c(LSPCLK)} - 10$ | $0.5t_{c(SPC)M} + 0.5t_{c(LSPCLK)} + 10$ | ns   |
| 6   | $t_{d(SIMO)M}$ Delay time, SPISIMO valid to SPICLK                | $0.5t_{c(SPC)M} - 10$ |                       | $0.5t_{c(SPC)M} + 0.5t_{c(LSPCLK)} - 10$ |  | ns   |
| 7   | $t_{v(SIMO)M}$ Valid time, SPISIMO valid after SPICLK             | $0.5t_{c(SPC)M} - 10$ |                       | $0.5t_{c(SPC)M} - 0.5t_{c(LSPCLK)} - 10$ |  | ns   |
| 10  | $t_{su(SOMI)M}$ Setup time, SPISOMI before SPICLK                 | 35                    |                       | 35                                       |  | ns   |
| 11  | $t_{h(SOMI)M}$ Hold time, SPISOMI valid after SPICLK              | 0                     |                       | 0  |  | ns   |
| 23  | $t_{d(SPC)M}$ Delay time, $\overline{SPISTE}$ active to SPICLK    | $t_{c(SPC)} - 10$     |                       | $t_{c(SPC)} - 10$                        |  | ns   |
| 24  | $t_{d(STEM)M}$ Delay time, SPICLK to $\overline{SPISTE}$ inactive | $0.5t_{c(SPC)} - 10$  |                       | $0.5t_{c(SPC)} - 0.5t_{c(LSPCLK)} - 10$  |  | ns   |

- (1) The MASTER/SLAVE bit (SPICTL.2) is set and the CLOCK PHASE bit (SPICTL.3) is set.
- (2)  $t_{c(SPC)} = \text{SPI clock cycle time} = \text{LSPCLK}/4$  or  $\text{LSPCLK}/(\text{SPIBRR} + 1)$
- (3) Internal clock prescalers must be adjusted such that the SPI clock speed is limited to the following SPI clock rate:  
 Master mode transmit 25 MHz MAX, master mode receive 12.5 MHz MAX  
 Slave mode transmit 12.5 MHz MAX, slave mode receive 12.5 MHz MAX.
- (4)  $t_{c(LCO)} = \text{LSPCLK cycle time}$
- (5) The active edge of the SPICLK signal referenced is controlled by the CLOCK POLARITY bit (SPICCR.6).

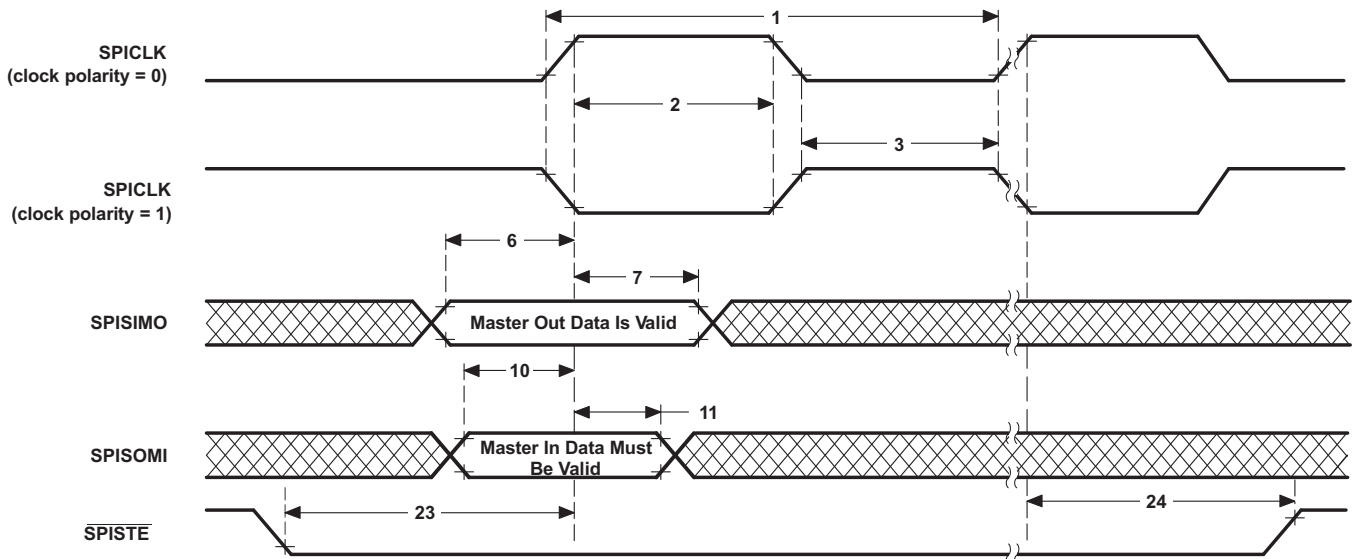

Figure 5-53. SPI Master Mode External Timing (Clock Phase = 1)

5.12.6.2.2 Slave Mode Timing

Table 5-79 lists the slave mode timing (clock phase = 0) and Table 5-80 lists the slave mode timing (clock phase = 1). Figure 5-54 and Figure 5-55 show the timing waveforms.

Table 5-79. SPI Slave Mode External Timing (Clock Phase = 0)<sup>(1)(2)(3)(4)(5)</sup>

| NO. | PARAMETER   | MIN                  | MAX | UNIT |
|-----|---|----------------------|-----|------|
| 12  | $t_{c(SPC)S}$ Cycle time, SPICLK                                    | $4t_{c(SYSCLK)}$     |     | ns   |
| 13  | $t_{w(SPC1)S}$ Pulse duration, SPICLK first pulse                   | $2t_{c(SYSCLK)} - 1$ |     | ns   |
| 14  | $t_{w(SPC2)S}$ Pulse duration, SPICLK second pulse                  | $2t_{c(SYSCLK)} - 1$ |     | ns   |
| 15  | $t_{d(SOMI)S}$ Delay time, SPICLK to SPISOMI valid                  |                      | 35  | ns   |
| 16  | $t_{v(SOMI)S}$ Valid time, SPISOMI data valid after SPICLK          | 0                    |     | ns   |
| 19  | $t_{su(SIMO)S}$ Setup time, SPISIMO valid before SPICLK             | $1.5t_{c(SYSCLK)}$   |     | ns   |
| 20  | $t_{h(SIMO)S}$ Hold time, SPISIMO data valid after SPICLK           | $1.5t_{c(SYSCLK)}$   |     | ns   |
| 25  | $t_{su(STE)S}$ Setup time, $\overline{SPISTE}$ active before SPICLK | $1.5t_{c(SYSCLK)}$   |     | ns   |
| 26  | $t_{h(STE)S}$ Hold time, $\overline{SPISTE}$ inactive after SPICLK  | $1.5t_{c(SYSCLK)}$   |     | ns   |

- (1) The MASTER / SLAVE bit (SPICTL.2) is cleared and the CLOCK PHASE bit (SPICTL.3) is cleared.
- (2)  $t_{c(SPC)}$  = SPI clock cycle time = LSPCLK/4 or LSPCLK/(SPIBRR + 1)
- (3) Internal clock prescalers must be adjusted such that the SPI clock speed is limited to the following SPI clock rate:  
Master mode transmit 25-MHz MAX, master mode receive 12.5-MHz MAX  
Slave mode transmit 12.5-MHz MAX, slave mode receive 12.5-MHz MAX.
- (4)  $t_{c(LCO)}$  = LSPCLK cycle time
- (5) The active edge of the SPICLK signal referenced is controlled by the CLOCK POLARITY bit (SPICCR.6).

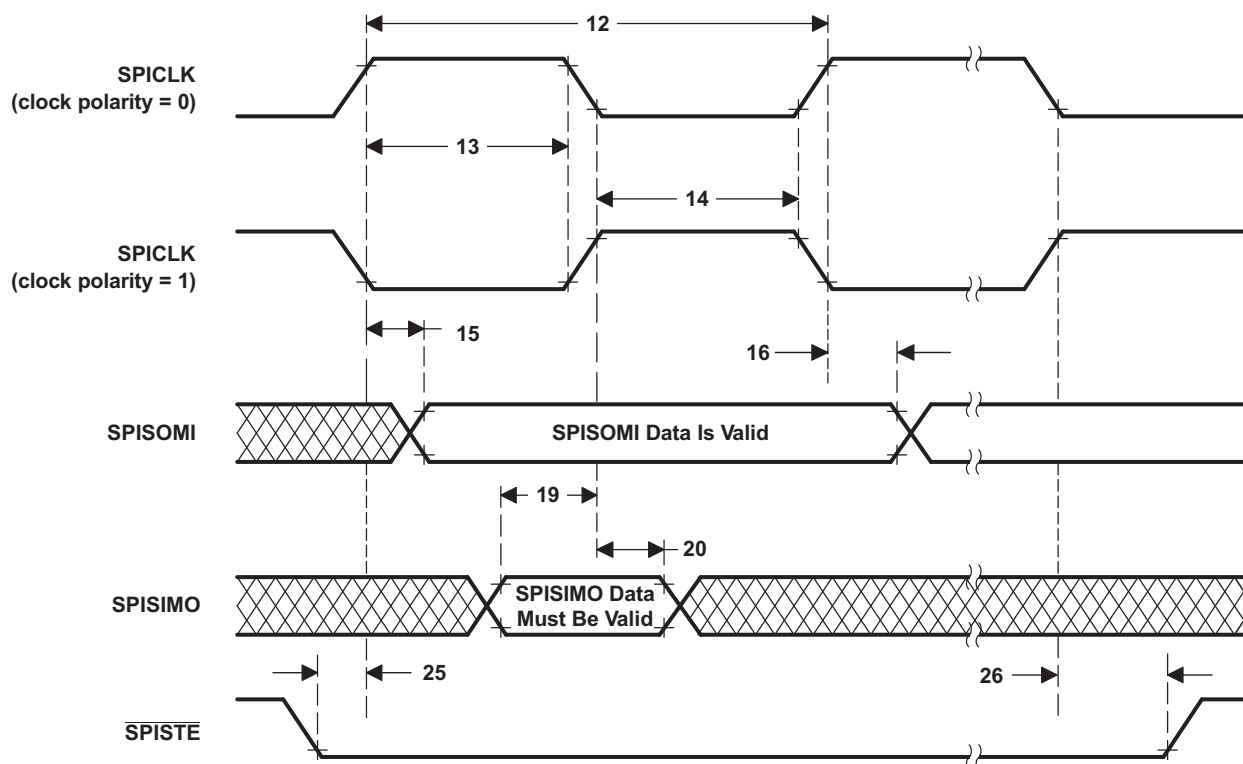
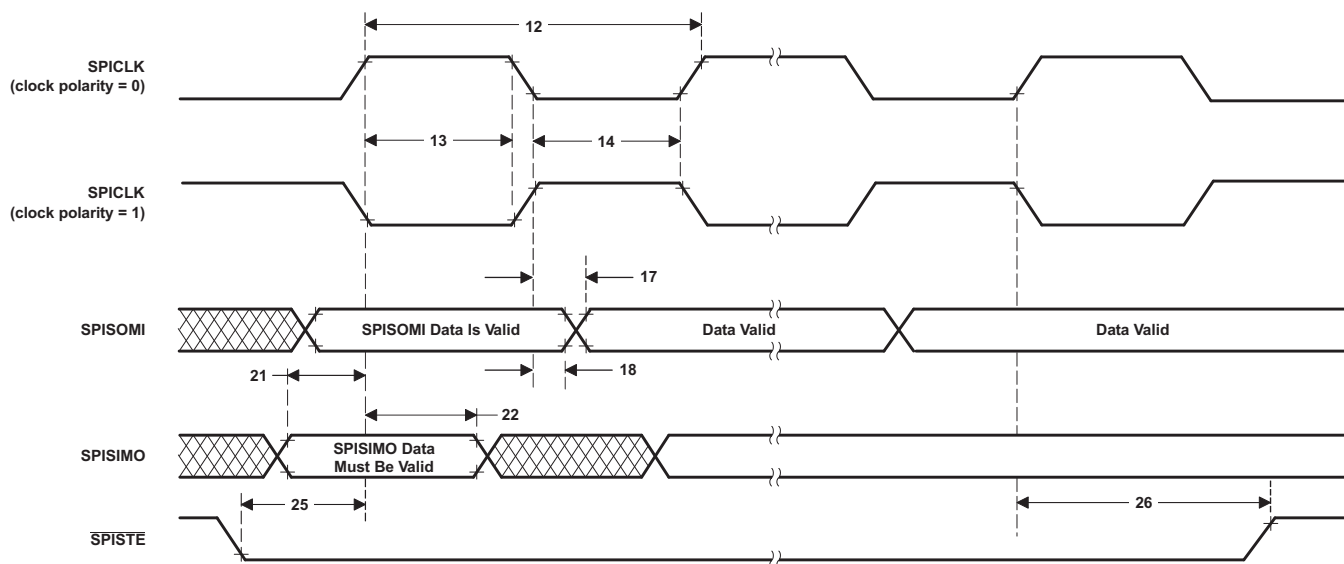

Figure 5-54. SPI Slave Mode External Timing (Clock Phase = 0)

**Table 5-80. SPI Slave Mode External Timing (Clock Phase = 1)<sup>(1)(2)(3)(4)</sup>**

| NO. | PARAMETER   | MIN                  | MAX | UNIT |
|-----|---|----------------------|-----|------|
| 12  | $t_{c(SPC)}S$ Cycle time, SPICLK                                    | $4t_{c(SYSCLK)}$     |     | ns   |
| 13  | $t_{w(SPC1)}S$ Pulse duration, SPICLK first pulse                   | $2t_{c(SYSCLK)} - 1$ |     | ns   |
| 14  | $t_{w(SPC2)}S$ Pulse duration, SPICLK second pulse                  | $2t_{c(SYSCLK)} - 1$ |     | ns   |
| 17  | $t_{d(SOMI)}S$ Delay time, SPICLK to SPISOMI valid                  |                      | 35  | ns   |
| 18  | $t_{v(SOMI)}S$ Valid time, SPISOMI data valid after SPICLK          | 0                    |     | ns   |
| 21  | $t_{su(SIMO)}S$ Setup time, SPISIMO valid before SPICLK             | $1.5t_{c(SYSCLK)}$   |     | ns   |
| 22  | $t_{h(SIMO)}S$ Hold time, SPISIMO data valid after SPICLK           | $1.5t_{c(SYSCLK)}$   |     | ns   |
| 25  | $t_{su(STE)}S$ Setup time, $\overline{SPISTE}$ active before SPICLK | $1.5t_{c(SYSCLK)}$   |     | ns   |
| 26  | $t_{h(STE)}S$ Hold time, $\overline{SPISTE}$ inactive after SPICLK  | $1.5t_{c(SYSCLK)}$   |     | ns   |

- (1) The MASTER / SLAVE bit (SPICTL.2) is cleared and the CLOCK PHASE bit (SPICTL.3) is cleared.
- (2)  $t_{c(SPC)}$  = SPI clock cycle time = LSPCLK/4 or LSPCLK/(SPIBRR + 1)
- (3) Internal clock prescalers must be adjusted such that the SPI clock speed is limited to the following SPI clock rate:  
 Master mode transmit 25-MHz MAX, master mode receive 12.5-MHz MAX  
 Slave mode transmit 12.5-MHz MAX, slave mode receive 12.5-MHz MAX.
- (4) The active edge of the SPICLK signal referenced is controlled by the CLOCK POLARITY bit (SPICCR.6).



**Figure 5-55. SPI Slave Mode External Timing (Clock Phase = 1)**

### 5.12.7 C28x Multichannel Buffered Serial Port

This device provides one high-speed McBSP that allows direct interface to codecs and other devices. The CPU accesses data, control, and status information. The McBSP also supports  $\mu$ DMA transfers.

The McBSP consists of a data-flow path and a control path connected to external devices by six pins. Data is communicated to devices interfaced with the McBSP through the data transmit (DX) pin for transmission and through the data receive (DR) pin for reception. Control information in the form of clocking and frame synchronization is communicated through the following pins: CLKX (transmit clock), CLKR (receive clock), FSX (transmit frame synchronization), and FSR (receive frame synchronization).

The CPU and the DMA controller communicate with the McBSP through 16-bit-wide registers accessible through the internal peripheral bus. The CPU or the DMA controller writes the data to be transmitted to the data transmit registers (DXR1, DXR2). Data written to the DXRs is shifted out to DX through the transmit shift registers (XSR1, XSR2). Similarly, receive data on the DR pin is shifted into the receive shift registers (RSR1, RSR2) and copied into the receive buffer registers (RBR1, RBR2). The contents of the RBRs is then copied to the DRRs, which can be read by the CPU or the DMA controller. This method allows simultaneous movement of internal and external data communications.

DRR2, RBR2, RSR2, DXR2, and XSR2 are not used (written, read, or shifted) if the serial word length is 8 bits, 12 bits, or 16 bits. For larger word lengths, these registers are needed to hold the most significant bits.

The frame and clock loop-back is implemented at chip level to enable CLKX and FSX to drive CLKR and FSR. If the loop-back is enabled, the CLKR and FSR get their signals from the CLKX and FSX pads instead of the CLKR and FSR pins.

McBSP features include:

- Full-duplex communication
- Double-buffered transmission and triple-buffered reception, allowing a continuous data stream
- Independent clocking and framing for reception and transmission
- The capability to send interrupts to the CPU and to send DMA events to the DMA controller
- 128 channels for transmission and reception
- Multichannel selection modes that enable or disable block transfers in each of the channels
- Direct interface to industry-standard codecs, analog interface chips (AICs), and other serially connected A/D and D/A devices
- Support for external generation of clock signals and frame-synchronization signals
- A programmable sample rate generator for internal generation and control of clock signals and frame synchronization signals
- Programmable polarity for frame-synchronization pulses and clock signals
- Direct interface to:
  - T1/E1 framers
  - IOM-2 compliant devices
  - AC97-compliant devices (the necessary multi-phase frame capability is provided)
  - I2S compliant devices
  - SPI devices
- A wide selection of data sizes: 8, 12, 16, 20, 24, and 32 bits

---

#### NOTE

A value of the chosen data size is referred to as a **serial word** or **word** in this section. Elsewhere, **word** is used to describe a 16-bit value.

---

- $\mu$ -law and A-law companding
- The option of transmitting/receiving 8-bit data with the LSB first
- Status bits for flagging exception/error conditions
- ABIS mode is not supported

Figure 5-56 shows the C28x McBSP peripheral.

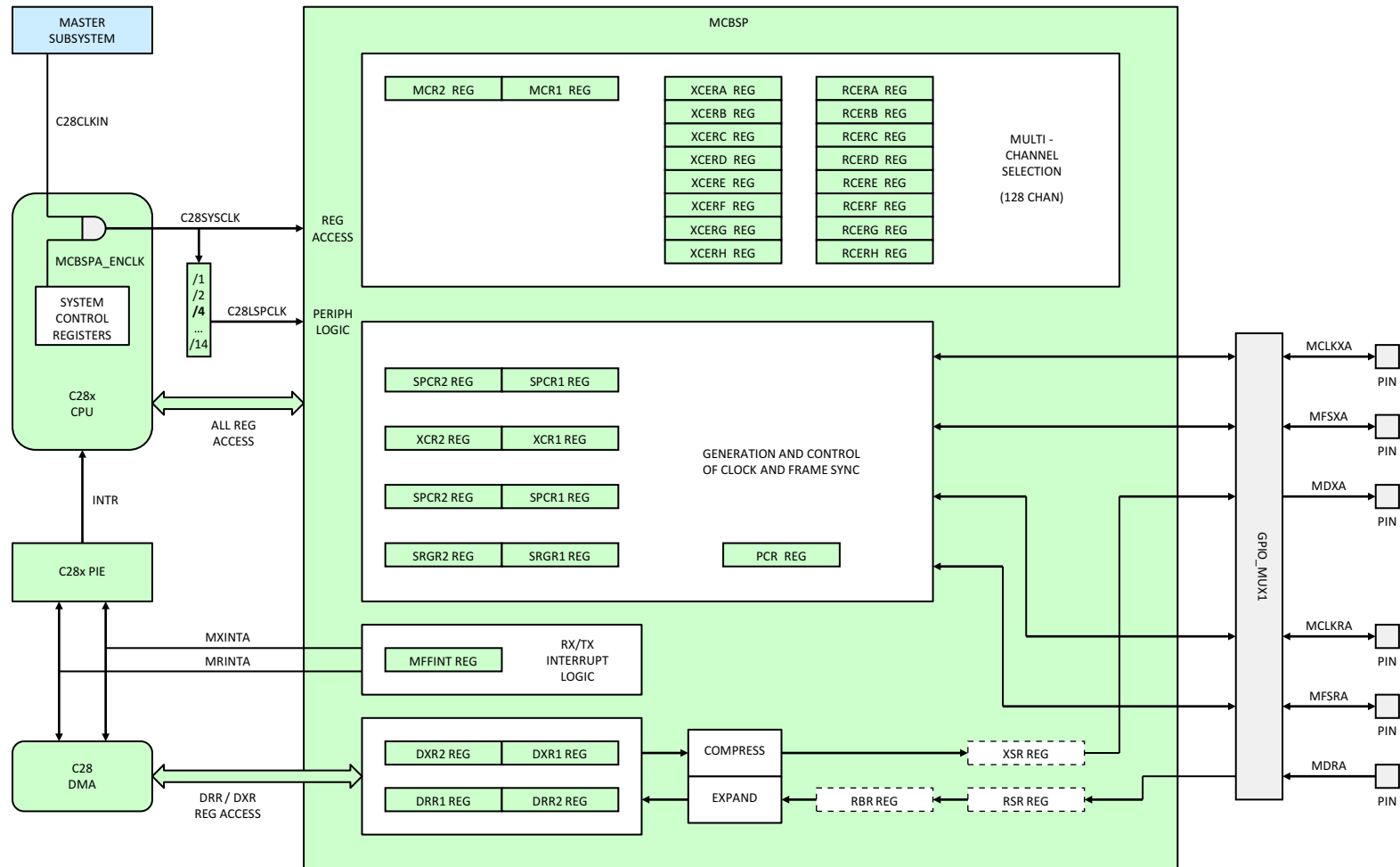

Figure 5-56. McBSP (C28x)

**5.12.7.1 McBSP Electrical Data and Timing**
**5.12.7.1.1 McBSP Transmit and Receive Timing**
**Table 5-81. McBSP Timing Requirements<sup>(1) (2)</sup>**

| NO. |  |   |            | MIN   | MAX               | UNIT |
|-----|--|---|------------|-------|-------------------|------|
|     | McBSP module clock (CLKG, CLKX, CLKR) range      |   |            | 1     |                   | kHz  |
|     |  |   |            |       | 25 <sup>(3)</sup> | MHz  |
|     | McBSP module cycle time (CLKG, CLKX, CLKR) range |   |            | 40    |                   | ns   |
|     |  |   |            |       | 1                 | ms   |
| M11 | $t_{c(\text{CKRX})}$                             | Cycle time, CLKR/X                            | CLKR/X ext | 2P    |                   | ns   |
| M12 | $t_{w(\text{CKRX})}$                             | Pulse duration, CLKR/X high or CLKR/X low     | CLKR/X ext | P – 7 |                   | ns   |
| M13 | $t_{r(\text{CKRX})}$                             | Rise time, CLKR/X                             | CLKR/X ext |       | 7                 | ns   |
| M14 | $t_{f(\text{CKRX})}$                             | Fall time, CLKR/X                             | CLKR/X ext |       | 7                 | ns   |
| M15 | $t_{su(\text{FRH-CKRL})}$                        | Setup time, external FSR high before CLKR low | CLKR int   | 18    |                   | ns   |
|     |  |   | CLKR ext   | 2     |                   |      |
| M16 | $t_{h(\text{CKRL-FRH})}$                         | Hold time, external FSR high after CLKR low   | CLKR int   | 0     |                   | ns   |
|     |  |   | CLKR ext   | 6     |                   |      |
| M17 | $t_{su(\text{DRV-CKRL})}$                        | Setup time, DR valid before CLKR low          | CLKR int   | 18    |                   | ns   |
|     |  |   | CLKR ext   | 5     |                   |      |
| M18 | $t_{h(\text{CKRL-DRV})}$                         | Hold time, DR valid after CLKR low            | CLKR int   | 0     |                   | ns   |
|     |  |   | CLKR ext   | 3     |                   |      |
| M19 | $t_{su(\text{FXH-CKXL})}$                        | Setup time, external FSX high before CLKX low | CLKX int   | 18    |                   | ns   |
|     |  |   | CLKX ext   | 2     |                   |      |
| M20 | $t_{h(\text{CKXL-FXH})}$                         | Hold time, external FSX high after CLKX low   | CLKX int   | 0     |                   | ns   |
|     |  |   | CLKX ext   | 6     |                   |      |

- (1) Polarity bits CLKRP = CLKXP = FSRP = FSXP = 0. If the polarity of any of the signals is inverted, then the timing references of that signal are also inverted.
- (2)  $2P = 1/\text{CLKG}$  in ns. CLKG is the output of sample rate generator mux.  $\text{CLKG} = \text{CLKSRG} / (1 + \text{CLKGDV})$ . CLKSRG can be LSPCLK, CLKX, CLKR as source.  $\text{CLKSRG} \leq (\text{SYSCLKOUT}/2)$ . McBSP performance is limited by I/O buffer switching speed.
- (3) Internal clock prescalers must be adjusted such that the McBSP clock (CLKG, CLKX, CLKR) speeds are not greater than the I/O buffer speed limit (30 MHz).

**Table 5-82. McBSP Switching Characteristics<sup>(1) (2)</sup>**

over recommended operating conditions (unless otherwise noted)

| NO. | PARAMETER            |  | MIN        | MAX                                       | UNIT   |    |    |
|-----|----------------------|--|------------|---|--------|----|----|
| M1  | $t_{c(CKRX)}$        | Cycle time, CLKR/X   | CLKR/X int | 2P  | ns     |    |    |
| M2  | $t_{w(CKRXH)}$       | Pulse duration, CLKR/X high  | CLKR/X int | D – 5 <sup>(3)</sup> D + 5 <sup>(3)</sup> | ns     |    |    |
| M3  | $t_{w(CKRXL)}$       | Pulse duration, CLKR/X low   | CLKR/X int | C – 5 <sup>(3)</sup> C + 5 <sup>(3)</sup> | ns     |    |    |
| M4  | $t_{d(CKRH-FRV)}$    | Delay time, CLKR high to internal FSR valid  | CLKR int   | 0   | 4      | ns |    |
|     |                      |  | CLKR ext   | 3   | 27     |    |    |
| M5  | $t_{d(CKXH-FXV)}$    | Delay time, CLKX high to internal FSX valid  | CLKX int   | 0   | 4      | ns |    |
|     |                      |  | CLKX ext   | 3   | 27     |    |    |
| M6  | $t_{dis(CKXH-DXHZ)}$ | Disable time, CLKX high to DX high impedance following last data bit   | CLKX int   |   | 8      | ns |    |
|     |                      |  | CLKX ext   |   | 14     |    |    |
| M7  | $t_{d(CKXH-DXV)}$    | Delay time, CLKX high to DX valid. This applies to all bits except the first bit transmitted.                                    | CLKX int   |   | 9      | ns |    |
|     |                      |  | CLKX ext   |   | 28     |    |    |
|     |                      |  | DXENA = 0  | CLKX int                                  |        |    | 8  |
|     |                      |  | DXENA = 0  | CLKX ext                                  |        |    | 14 |
| M8  | $t_{en(CKXH-DX)}$    | Enable time, CLKX high to DX driven. Only applies to first bit transmitted when in Data Delay 1 or 2 (XDATDLY=01b or 10b) modes. | DXENA = 1  | CLKX int                                  | P + 8  | ns |    |
|     |                      |  | DXENA = 1  | CLKX ext                                  | P + 14 |    |    |
|     |                      |  | DXENA = 0  | CLKX int                                  | 0      |    |    |
|     |                      |  |            | CLKX ext                                  | 6      |    |    |
| M9  | $t_{d(FXH-DXV)}$     | Delay time, FSX high to DX valid. Only applies to first bit transmitted when in Data Delay 0 (XDATDLY=00b) mode.                 | DXENA = 0  | FSX int                                   | 8      | ns |    |
|     |                      |  | DXENA = 0  | FSX ext                                   | 14     |    |    |
|     |                      |  | DXENA = 1  | FSX int                                   | P + 8  |    |    |
|     |                      |  |            | FSX ext                                   | P + 14 |    |    |
| M10 | $t_{en(FXH-DX)}$     | Enable time, FSX high to DX driven. Only applies to first bit transmitted when in Data Delay 0 (XDATDLY=00b) mode.               | DXENA = 0  | FSX int                                   | 0      | ns |    |
|     |                      |  | DXENA = 0  | FSX ext                                   | 6      |    |    |
|     |                      |  | DXENA = 1  | FSX int                                   | P      |    |    |
|     |                      |  |            | FSX ext                                   | P + 6  |    |    |

- (1) Polarity bits CLKRP = CLKXP = FSRP = FSXP = 0. If the polarity of any of the signals is inverted, then the timing references of that signal are also inverted.
- (2) 2P = 1/CLKG in ns.
- (3) C = CLKRX low pulse width = P  
D = CLKRX high pulse width = P

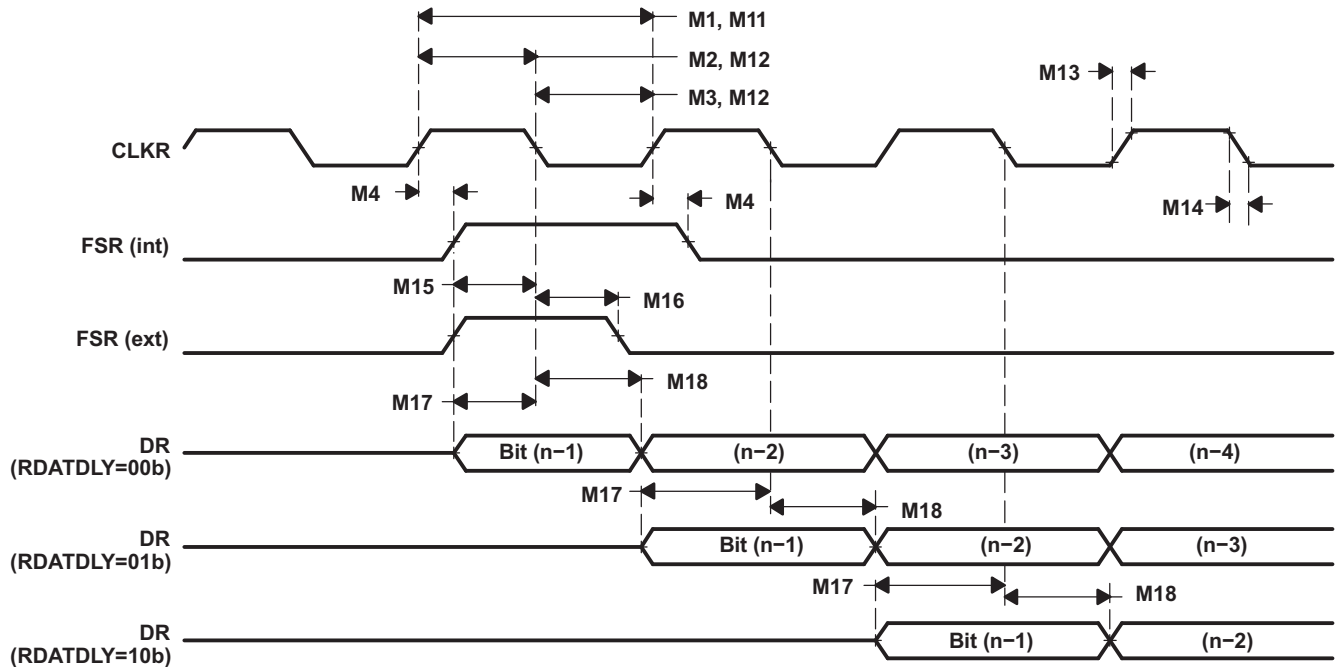

Figure 5-57. McBSP Receive Timing

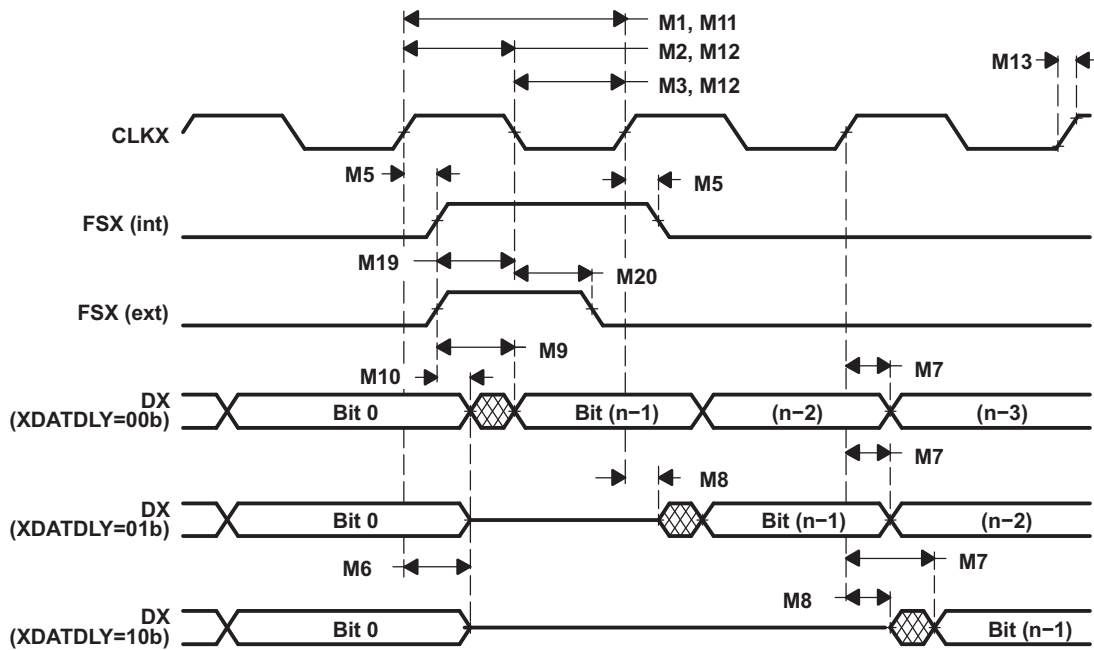

Figure 5-58. McBSP Transmit Timing

**5.12.7.1.2 McBSP as SPI Master or Slave Timing**

**Table 5-83. McBSP as SPI Master or Slave Timing Requirements (CLKSTP = 10b, CLKXP = 0)<sup>(1)</sup>**

| NO. |                     |                                      | MASTER            |     | SLAVE   |     | UNIT |
|-----|---------------------|--------------------------------------|-------------------|-----|---------|-----|------|
|     |                     |                                      | MIN               | MAX | MIN     | MAX |      |
| M30 | $t_{su}(DRV-CKXL)$  | Setup time, DR valid before CLKX low | 30                |     | 8P – 10 |     | ns   |
| M31 | $t_h(CKXL-DRV)$     | Hold time, DR valid after CLKX low   | 1                 |     | 8P – 10 |     | ns   |
| M32 | $t_{su}(BFXL-CKXH)$ | Setup time, FSX low before CLKX high |                   |     | 8P + 10 |     | ns   |
| M33 | $t_c(CKX)$          | Cycle time, CLKX                     | 2P <sup>(2)</sup> |     | 16P     |     | ns   |

(1) For all SPI slave modes, CLKX has to be a minimum of 8 CLKG cycles. Furthermore, CLKG should be LSPCLK/2 by setting CLKSM = CLKGDV = 1.

(2) 2P = 1/CLKG

**Table 5-84. McBSP as SPI Master or Slave Switching Characteristics Over Recommended Operating Conditions (Unless Otherwise Noted) (CLKSTP = 10b, CLKXP = 0)**

| NO. | PARAMETER           | MASTER            |     | SLAVE  |     | UNIT |
|-----|---------------------|-------------------|-----|--------|-----|------|
|     |                     | MIN               | MAX | MIN    | MAX |      |
| M24 | $t_h(CKXL-FXL)$     | 2P <sup>(1)</sup> |     |        |     | ns   |
| M25 | $t_d(FXL-CKXH)$     | P                 |     |        |     | ns   |
| M28 | $t_{dis}(FXH-DXHZ)$ | 6                 |     | 6P + 6 |     | ns   |
| M29 | $t_d(FXL-DXV)$      | 6                 |     | 4P + 6 |     | ns   |

(1) 2P = 1/CLKG

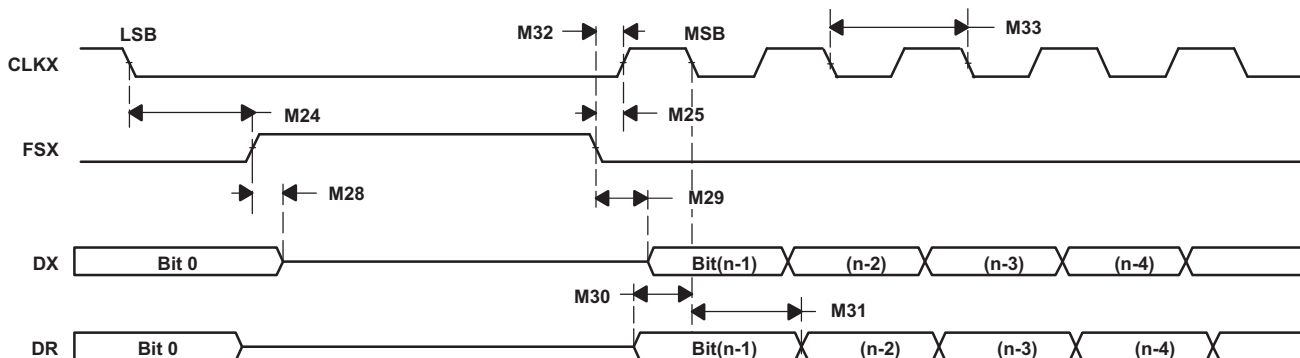

**Figure 5-59. McBSP Timing as SPI Master or Slave: CLKSTP = 10b, CLKXP = 0**

**Table 5-85. McBSP as SPI Master or Slave Timing Requirements (CLKSTP = 11b, CLKXP = 0)<sup>(1)</sup>**

| NO. |                    |                                       | MASTER            |     | SLAVE    |     | UNIT |
|-----|--------------------|---------------------------------------|-------------------|-----|----------|-----|------|
|     |                    |                                       | MIN               | MAX | MIN      | MAX |      |
| M39 | $t_{su(DRV-CKXH)}$ | Setup time, DR valid before CLKX high | 30                |     | 8P – 10  |     | ns   |
| M40 | $t_h(CKXH-DRV)$    | Hold time, DR valid after CLKX high   | 1                 |     | 8P – 10  |     | ns   |
| M41 | $t_{su(FXL-CKXH)}$ | Setup time, FSX low before CLKX high  |                   |     | 16P + 10 |     | ns   |
| M42 | $t_c(CKX)$         | Cycle time, CLKX                      | 2P <sup>(2)</sup> |     | 16P      |     | ns   |

- (1) For all SPI slave modes, CLKX has to be a minimum of 8 CLKG cycles. Furthermore, CLKG should be LSPCLK/2 by setting CLKSM = CLKGDV = 1.  
 (2) 2P = 1/CLKG

**Table 5-86. McBSP as SPI Master or Slave Switching Characteristics Over Recommended Operating Conditions (Unless Otherwise Noted) (CLKSTP = 11b, CLKXP = 0)**

| NO. | PARAMETER            | MASTER |                   | SLAVE |        | UNIT |
|-----|----------------------|--------|-------------------|-------|--------|------|
|     |                      | MIN    | MAX               | MIN   | MAX    |      |
| M34 | $t_h(CKXL-FXL)$      |        | P                 |       |        | ns   |
| M35 | $t_d(FXL-CKXH)$      |        | 2P <sup>(1)</sup> |       |        | ns   |
| M37 | $t_{dis}(CKXL-DXHZ)$ |        | P + 6             |       | 7P + 6 | ns   |
| M38 | $t_d(FXL-DXV)$       |        | 6                 |       | 4P + 6 | ns   |

- (1) 2P = 1/CLKG

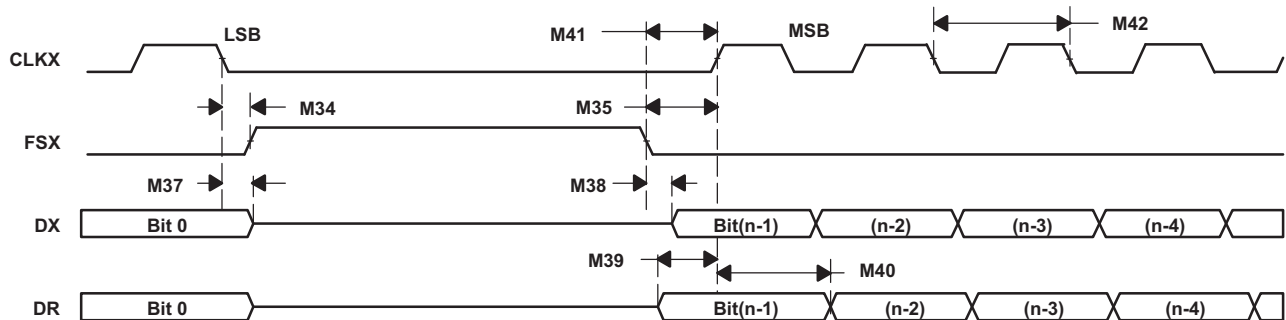

**Figure 5-60. McBSP Timing as SPI Master or Slave: CLKSTP = 11b, CLKXP = 0**

**Table 5-87. McBSP as SPI Master or Slave Timing Requirements (CLKSTP = 10b, CLKXP = 1)<sup>(1)</sup>**

| NO. |                    |                                       | MASTER            |     | SLAVE   |     | UNIT |
|-----|--------------------|---------------------------------------|-------------------|-----|---------|-----|------|
|     |                    |                                       | MIN               | MAX | MIN     | MAX |      |
| M49 | $t_{su}(DRV-CKXH)$ | Setup time, DR valid before CLKX high | 30                |     | 8P – 10 |     | ns   |
| M50 | $t_h(CKXH-DRV)$    | Hold time, DR valid after CLKX high   | 1                 |     | 8P – 10 |     | ns   |
| M51 | $t_{su}(FXL-CKXL)$ | Setup time, FSX low before CLKX low   |                   |     | 8P + 10 |     | ns   |
| M52 | $t_c(CKX)$         | Cycle time, CLKX                      | 2P <sup>(2)</sup> |     | 16P     |     | ns   |

(1) For all SPI slave modes, CLKX has to be a minimum of 8 CLKG cycles. Furthermore, CLKG should be LSPCLK/2 by setting CLKSM = CLKGDV = 1.

(2) 2P = 1/CLKG

**Table 5-88. McBSP as SPI Master or Slave Switching Characteristics Over Recommended Operating Conditions (Unless Otherwise Noted) (CLKSTP = 10b, CLKXP = 1)**

| NO. | PARAMETER           | MASTER            |     | SLAVE  |     | UNIT |
|-----|---------------------|-------------------|-----|--------|-----|------|
|     |                     | MIN               | MAX | MIN    | MAX |      |
| M43 | $t_h(CKXH-FXL)$     | 2P <sup>(1)</sup> |     |        |     | ns   |
| M44 | $t_d(FXL-CKXL)$     | P                 |     |        |     | ns   |
| M47 | $t_{dis}(FXH-DXHZ)$ | 6                 |     | 6P + 6 |     | ns   |
| M48 | $t_d(FXL-DXV)$      | 6                 |     | 4P + 6 |     | ns   |

(1) 2P = 1/CLKG

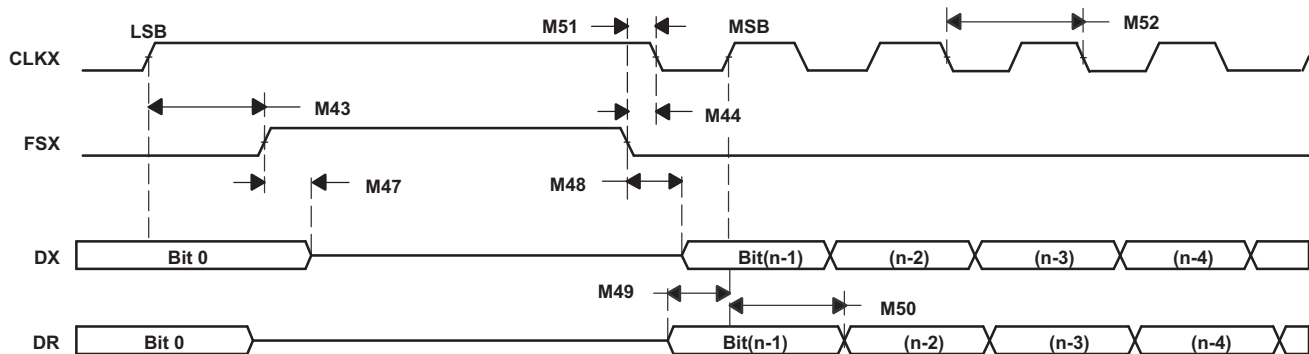

**Figure 5-61. McBSP Timing as SPI Master or Slave: CLKSTP = 10b, CLKXP = 1**

**Table 5-89. McBSP as SPI Master or Slave Timing Requirements (CLKSTP = 11b, CLKXP = 1)<sup>(1)</sup>**

| NO. |                    |                                      | MASTER            |     | SLAVE    |     | UNIT |
|-----|--------------------|--------------------------------------|-------------------|-----|----------|-----|------|
|     |                    |                                      | MIN               | MAX | MIN      | MAX |      |
| M58 | $t_{su(DRV-CKXL)}$ | Setup time, DR valid before CLKX low | 30                |     | 8P – 10  |     | ns   |
| M59 | $t_{h(CKXL-DRV)}$  | Hold time, DR valid after CLKX low   | 1                 |     | 8P – 10  |     | ns   |
| M60 | $t_{su(FXL-CKXL)}$ | Setup time, FSX low before CLKX low  |                   |     | 16P + 10 |     | ns   |
| M61 | $t_{c(CKX)}$       | Cycle time, CLKX                     | 2P <sup>(2)</sup> |     | 16P      |     | ns   |

- (1) For all SPI slave modes, CLKX has to be a minimum of 8 CLKG cycles. Furthermore, CLKG should be LSPCLK/2 by setting CLKSM = CLKGDV = 1.  
 (2) 2P = 1/CLKG

**Table 5-90. McBSP as SPI Master or Slave Switching Characteristics Over Recommended Operating Conditions (Unless Otherwise Noted) (CLKSTP = 11b, CLKXP = 1)<sup>(1)</sup>**

| NO. | PARAMETER            | MASTER <sup>(2)</sup>  |                   | SLAVE |        | UNIT    |    |
|-----|----------------------|--|-------------------|-------|--------|---------|----|
|     |                      | MIN  | MAX               | MIN   | MAX    |         |    |
| M53 | $t_{h(CKXH-FXL)}$    | Hold time, FSX low after CLKX high                                     | P                 |       |        | ns      |    |
| M54 | $t_{d(FXL-CKXL)}$    | Delay time, FSX low to CLKX low  | 2P <sup>(1)</sup> |       |        | ns      |    |
| M55 | $t_{d(CLKXH-DXV)}$   | Delay time, CLKX high to DX valid                                      | -2                | 0     | 3P + 6 | 5P + 20 | ns |
| M56 | $t_{dis(CKXH-DXHZ)}$ | Disable time, DX high impedance following last data bit from CLKX high | P + 6             |       | 7P + 6 |         | ns |
| M57 | $t_{d(FXL-DXV)}$     | Delay time, FSX low to DX valid  | 6                 |       | 4P + 6 |         | ns |

- (1) 2P = 1/CLKG  
 (2) C = CLKX low pulse width = P  
 D = CLKX high pulse width = P

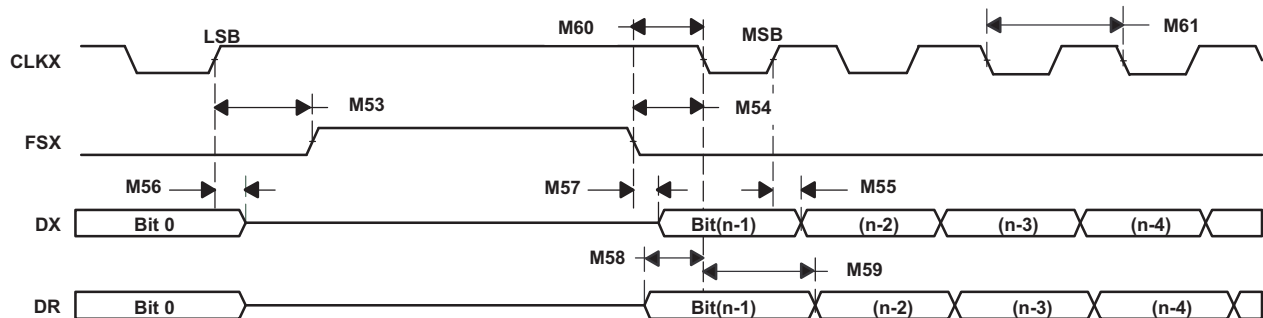

**Figure 5-62. McBSP Timing as SPI Master or Slave: CLKSTP = 11b, CLKXP = 1**

## 6 Detailed Description

The Concerto MCU comprises three subsystems: the Master Subsystem, the Control Subsystem, and the Analog Subsystem. While the Master and Control Subsystem each have dedicated local memories and peripherals, they can also share data and events through shared memories and peripherals. The Analog Subsystem has two ADC converters and six Analog Comparators. Both the Master and Control Subsystems access the Analog Subsystem through the Analog Common Interface Bus (ACIB). The NMI Blocks force communication of critical events to the Master and Control Subsystem processors and their Watchdog Timers. The Reset Block responds to Watchdog Timer NMI Reset, External Reset, and other events to initialize subsystem processors and the rest of the chip to a known state. The Clocking Blocks support multiple low-power modes where clocks to the processors and peripherals can be slowed down or stopped in order to manage power consumption.

---

### NOTE

Throughout this document, the Master Subsystem is denoted by the color blue; the Control Subsystem is denoted by the color green; and the Analog Subsystem is denoted by the color orange.

---

## 6.1 Memory Maps

Section 6.1.1 shows the Control Subsystem Memory Map. Section 6.1.2 shows the Master Subsystem Memory Map.

### 6.1.1 Control Subsystem Memory Map

**Table 6-1. Control Subsystem M0, M1 RAM**

| C DMA ACCESS <sup>(1)</sup> | C ADDRESS (x16 ALIGNED) <sup>(1)</sup> | CONTROL SUBSYSTEM M0, M1 RAM | SIZE (BYTES) |
|-----------------------------|--|------------------------------|--------------|
| no                          | 0000 0000 – 0000 03FF                  | M0 RAM (ECC)                 | 2K           |
| no                          | 0000 0400 – 0000 07FF                  | M1 RAM (ECC)                 | 2K           |

(1) The letter "C" refers to the Control Subsystem.

**Table 6-2. Control Subsystem Peripheral Frame 0**

| C DMA ACCESS <sup>(1)</sup> | C ADDRESS (x16 ALIGNED) <sup>(1)</sup> | CONTROL SUBSYSTEM PERIPHERAL FRAME 0 (INCLUDES ANALOG)       | SIZE (BYTES) |
|-----------------------------|--|--|--------------|
|                             | 0000 0800 – 0000 087F                  | Reserved   |              |
| no                          | 0000 0880 – 0000 0890                  | Control Subsystem Device Configuration Registers (Read Only) | 34           |
|                             | 0000 0891 – 0000 0ADF                  | Reserved   |              |
| no                          | 0000 0AE0 – 0000 0AEF                  | C28x CSM Registers   | 32           |
|                             | 0000 0AF0 – 0000 0AFF                  | Reserved   |              |
| yes                         | 0000 0B00 – 0000 0B0F                  | ADC1 Result Registers  | 32           |
|                             | 0000 0B10 – 0000 0B3F                  | Reserved   |              |
| yes                         | 0000 0B40 – 0000 0B4F                  | ADC2 Result Registers  | 32           |
|                             | 0000 0B50 – 0000 0BFF                  | Reserved   |              |
| no                          | 0000 0C00 – 0000 0C07                  | CPU Timer 0  | 16           |
| no                          | 0000 0C08 – 0000 0C0F                  | CPU Timer 1  | 16           |
| no                          | 0000 0C10 – 0000 0C17                  | CPU Timer 2  | 16           |
|                             | 0000 0C18 – 0000 0CDF                  | Reserved   |              |
| no                          | 0000 0CE0 – 0000 0CFF                  | PIE Registers  | 64           |
| no                          | 0000 0D00 – 0000 0DFF                  | PIE Vector Table   | 512          |
| no                          | 0000 0E00 – 0000 0EFF                  | PIE Vector Table Copy (Read Only)                            | 512          |
|                             | 0000 0F00 – 0000 0FFF                  | Reserved   |              |
| no                          | 0000 1000 – 0000 11FF                  | C28x DMA Registers   | 1K           |
|                             | 0000 1200 – 0000 16FF                  | Reserved   |              |
| no                          | 0000 1700 – 0000 177F                  | Analog Subsystem Control Registers                           | 256          |
| no                          | 0000 1780 – 0000 17FF                  | Hardware BIST Registers                                      | 256          |
|                             | 0000 1800 – 0000 3FFF                  | Reserved   |              |

(1) The letter "C" refers to the Control Subsystem.

**Table 6-3. Control Subsystem Peripheral Frame 3**

| C DMA ACCESS <sup>(1)</sup> | C ADDRESS (x16 ALIGNED) <sup>(1)</sup> | CONTROL SUBSYSTEM PERIPHERAL FRAME 3      | SIZE (BYTES) | M ADDRESS (BYTE-ALIGNED) <sup>(2)</sup> | μDMA ACCESS |
|-----------------------------|--|---|--------------|---|-------------|
| no                          | 0000 4000 – 0000 4181                  | C28x Flash Control Registers              | 772          |   |             |
|                             | 0000 4182 – 0000 42FF                  | Reserved                                  |              |   |             |
| no                          | 0000 4300 – 0000 4323                  | C28x Flash ECC Error Log Registers        | 72           |   |             |
|                             | 0000 4324 – 0000 43FF                  | Reserved                                  |              |   |             |
| no                          | 0000 4400 – 0000 443F                  | M Clock Control Registers <sup>(2)</sup>  | 128          | 400F B800 – 400F B87F                   | no          |
|                             | 0000 4440 – 0000 48FF                  | Reserved                                  |              |   |             |
| no                          | 0000 4900 – 0000 497F                  | RAM Configuration Registers               | 256          | 400F B200 – 400F B2FF                   | no          |
|                             | 0000 4980 – 0000 49FF                  | Reserved                                  |              |   |             |
| no                          | 0000 4A00 – 0000 4A7F                  | RAM ECC/Parity/Access Error Log Registers | 256          | 400F B300 – 400F B3FF                   | no          |
|                             | 0000 4A80 – 0000 4DFF                  | Reserved                                  |              |   |             |
| no                          | 0000 4E00 – 0000 4E3F                  | CtoM and MtoC IPC Registers               | 128          | 400F B700 – 400F B77F                   | no          |
|                             | 0000 4E40 – 0000 4FFF                  | Reserved                                  |              |   |             |
| yes                         | 0000 5000 – 0000 503F                  | McBSP-A                                   | 128          |   |             |
|                             | 0000 5040 – 0000 50FF                  | Reserved                                  |              |   |             |
| yes                         | 0000 5100 – 0000 517F                  | EPWM1 (Hi-Resolution)                     | 256          |   |             |
| yes                         | 0000 5180 – 0000 51FF                  | EPWM2 (Hi-Resolution)                     | 256          |   |             |
| yes                         | 0000 5200 – 0000 527F                  | EPWM3 (Hi-Resolution)                     | 256          |   |             |
| yes                         | 0000 5280 – 0000 52FF                  | EPWM4 (Hi-Resolution)                     | 256          |   |             |
| yes                         | 0000 5300 – 0000 537F                  | EPWM5 (Hi-Resolution)                     | 256          |   |             |
| yes                         | 0000 5380 – 0000 53FF                  | EPWM6 (Hi-Resolution)                     | 256          |   |             |
| yes                         | 0000 5400 – 0000 547F                  | EPWM7 (Hi-Resolution)                     | 256          |   |             |
| yes                         | 0000 5480 – 0000 54FF                  | EPWM8 (Hi-Resolution)                     | 256          |   |             |
| yes                         | 0000 5500 – 0000 557F                  | EPWM9                                     | 256          |   |             |
|                             | 0000 5580 – 0000 57FF                  | Reserved                                  |              |   |             |

(1) The letter "C" refers to the Control Subsystem.

(2) The letter "M" refers to the Master Subsystem.

**Table 6-4. Control Subsystem Peripheral Frame 1**

| C DMA ACCESS <sup>(1)</sup> | C ADDRESS<br>(x16 ALIGNED) <sup>(1)</sup> | CONTROL SUBSYSTEM PERIPHERAL FRAME 1                          | SIZE<br>(BYTES) |
|-----------------------------|---|---|-----------------|
|                             | 0000 5800 – 0000 59FF                     | Reserved  |                 |
| no                          | 0000 5A00 – 0000 5A1F                     | ECAP1   | 64              |
| no                          | 0000 5A20 – 0000 5A3F                     | ECAP2   | 64              |
| no                          | 0000 5A40 – 0000 5A5F                     | ECAP3   | 64              |
| no                          | 0000 5A60 – 0000 5A7F                     | ECAP4   | 64              |
| no                          | 0000 5A80 – 0000 5A9F                     | ECAP5   | 64              |
| no                          | 0000 5AA0 – 0000 5ABF                     | ECAP6   | 64              |
|                             | 0000 5AC0 – 0000 5AFF                     | Reserved  |                 |
| no                          | 0000 5B00 – 0000 5B3F                     | EQEP1   | 128             |
| no                          | 0000 5B40 – 0000 5B7F                     | EQEP2   | 128             |
| no                          | 0000 5B80 – 0000 5BBF                     | EQEP3   | 128             |
|                             | 0000 5BC0 – 0000 5F7F                     | Reserved  |                 |
| no                          | 0000 5F80 – 0000 5FFF                     | C GPIO Group 1 Registers <sup>(1)</sup>                       | 256             |
|                             | 0000 6000 – 0000 63FF                     | Reserved  |                 |
| no                          | 0000 6400 – 0000 641F                     | COMP1 Registers   | 64              |
| no                          | 0000 6420 – 0000 643F                     | COMP2 Registers   | 64              |
| no                          | 0000 6440 – 0000 645F                     | COMP3 Registers   | 64              |
| no                          | 0000 6460 – 0000 647F                     | COMP4 Registers   | 64              |
| no                          | 0000 6480 – 0000 649F                     | COMP5 Registers   | 64              |
| no                          | 0000 64A0 – 0000 64BF                     | COMP6 Registers   | 64              |
|                             | 0000 64C0 – 0000 6F7F                     | Reserved  |                 |
| no                          | 0000 6F80 – 0000 6FFF                     | C GPIO Group 2 Registers and AIO Mux Registers <sup>(1)</sup> | 256             |

(1) The letter "C" refers to the Control Subsystem.

**Table 6-5. Control Subsystem Peripheral Frame 2**

| C DMA ACCESS <sup>(1)</sup> | C ADDRESS<br>(x16 ALIGNED) <sup>(1)</sup> | CONTROL SUBSYSTEM PERIPHERAL FRAME 2                                      | SIZE<br>(BYTES) |
|-----------------------------|---|---|-----------------|
|                             | 0000 7000 – 0000 70FF                     | Reserved  |                 |
| no                          | 0000 7010 – 0000 702F                     | C28x System Control Registers   | 64              |
|                             | 0000 7030 – 0000 703F                     | Reserved  |                 |
| no                          | 0000 7040 – 0000 704F                     | SPI-A   | 32              |
| no                          | 0000 7050 – 0000 705F                     | SCI-A   | 32              |
| no                          | 0000 7060 – 0000 706F                     | NMI Watchdog Interrupt Registers  | 32              |
| no                          | 0000 7070 – 0000 707F                     | External Interrupt Registers  | 32              |
|                             | 0000 7080 – 0000 70FF                     | Reserved  |                 |
| no                          | 0000 7100 – 0000 717F                     | ADC1 Configuration Registers<br>(Only 16-bit read/write access supported) | 256             |
| no                          | 0000 7180 – 0000 71FF                     | ADC2 Configuration Registers<br>(Only 16-bit read/write access supported) | 256             |
|                             | 0000 7200 – 0000 78FF                     | Reserved  |                 |
| no                          | 0000 7900 – 0000 793F                     | I2C-A   | 128             |
|                             | 0000 7940 – 0000 7FFF                     | Reserved  |                 |

(1) The letter "C" refers to the Control Subsystem.

**Table 6-6. Control Subsystem RAMs**

| C DMA ACCESS <sup>(1)</sup> | C ADDRESS (x16 ALIGNED) <sup>(1)</sup> | CONTROL SUBSYSTEM RAMS        | SIZE (BYTES) | M ADDRESS (BYTE-ALIGNED) <sup>(2)</sup> | μDMA ACCESS   |
|-----------------------------|--|-------------------------------|--------------|---|---------------|
| no                          | 0000 8000 – 0000 8FFF                  | L0 RAM (ECC, Secure)          | 8K           |   |               |
| no                          | 0000 9000 – 0000 9FFF                  | L1 RAM (ECC, Secure)          | 8K           |   |               |
| yes                         | 0000 A000 – 0000 AFFF                  | L2 RAM (Parity, Interleaving) | 8K           |   |               |
| yes                         | 0000 B000 – 0000 BFFF                  | L3 RAM (Parity, Interleaving) | 8K           |   |               |
| yes                         | 0000 C000 – 0000 CFFF                  | S0 RAM (Parity, Shared)       | 8K           | 2000 8000 – 2000 9FFF                   | yes           |
| yes                         | 0000 D000 – 0000 DFFF                  | S1 RAM (Parity, Shared)       | 8K           | 2000 A000 – 2000 BFFF                   | yes           |
| yes                         | 0000 E000 – 0000 EFFF                  | S2 RAM (Parity, Shared)       | 8K           | 2000 C000 – 2000 DFFF                   | yes           |
| yes                         | 0000 F000 – 0000 FFFF                  | S3 RAM (Parity, Shared)       | 8K           | 2000 E000 – 2000 FFFF                   | yes           |
| yes                         | 0001 0000 – 0001 0FFF                  | S4 RAM (Parity, Shared)       | 8K           | 2001 0000 – 2001 1FFF                   | yes           |
| yes                         | 0001 1000 – 0001 1FFF                  | S5 RAM (Parity, Shared)       | 8K           | 2001 2000 – 2001 3FFF                   | yes           |
| yes                         | 0001 2000 – 0001 2FFF                  | S6 RAM (Parity, Shared)       | 8K           | 2001 4000 – 2001 5FFF                   | yes           |
| yes                         | 0001 3000 – 0001 3FFF                  | S7 RAM (Parity, Shared)       | 8K           | 2001 6000 – 2001 7FFF                   | yes           |
|                             | 0001 4000 – 0003 F7FF                  | Reserved                      |              |   |               |
| yes                         | 0003 F800 – 0003 FBFF                  | CtoM MSG RAM (Parity)         | 2K           | 2007 F000 – 2007 F7FF                   | yes read only |
| yes read only               | 0003 FC00 – 0003 FFFF                  | MtoC MSG RAM (Parity)         | 2K           | 2007 F800 – 2007 FFFF                   | yes           |
|                             | 0004 0000 – 0004 7FFF                  | Reserved                      |              |   |               |
| no                          | 0004 8000 – 0004 8FFF                  | L0 RAM - ECC Bits             | 8K           |   |               |
| no                          | 0004 9000 – 0004 9FFF                  | L1 RAM - ECC Bits             | 8K           |   |               |
| no                          | 0004 A000 – 0004 AFFF                  | L2 RAM - Parity Bits          | 8K           |   |               |
| no                          | 0004 B000 – 0004 BFFF                  | L3 RAM - Parity Bits          | 8K           |   |               |
| no                          | 0004 C000 – 0004 CFFF                  | S0 RAM - Parity Bits          | 8K           | 2008 8000 – 2008 9FFF                   | no            |
| no                          | 0004 D000 – 0004 DFFF                  | S1 RAM - Parity Bits          | 8K           | 2008 A000 – 2008 BFFF                   | no            |
| no                          | 0004 E000 – 0004 EFFF                  | S2 RAM - Parity Bits          | 8K           | 2008 C000 – 2008 DFFF                   | no            |
| no                          | 0004 F000 – 0004 FFFF                  | S3 RAM - Parity Bits          | 8K           | 2008 E000 – 2008 FFFF                   | no            |
| no                          | 0005 0000 – 0005 0FFF                  | S4 RAM - Parity Bits          | 8K           | 2009 0000 – 2009 1FFF                   | no            |
| no                          | 0005 1000 – 0005 1FFF                  | S5 RAM - Parity Bits          | 8K           | 2009 2000 – 2009 3FFF                   | no            |
| no                          | 0005 2000 – 0005 2FFF                  | S6 RAM - Parity Bits          | 8K           | 2009 4000 – 2009 5FFF                   | no            |
| no                          | 0005 3000 – 0005 3FFF                  | S7 RAM - Parity Bits          | 8K           | 2009 6000 – 2009 7FFF                   | no            |
|                             | 0005 4000 – 0007 EFFF                  | Reserved                      |              |   |               |
| no                          | 0007 F000 – 0007 F3FF                  | M0 RAM - ECC Bits             | 2K           |   |               |
| no                          | 0007 F400 – 0007 F7FF                  | M1 RAM - ECC Bits             | 2K           |   |               |
| no                          | 0007 F800 – 0007 FBFF                  | CtoM MSG RAM - Parity Bits    | 2K           | 200F F000 – 200F F7FF                   | no            |
| no                          | 0007 FC00 – 0007 FFFF                  | MtoC MSG RAM - Parity Bits    | 2K           | 200F F800 – 200F FFFF                   | no            |
|                             | 0008 0000 – 0009 FFFF                  | Reserved                      |              |   |               |

(1) The letter "C" refers to the Control Subsystem.

(2) The letter "M" refers to the Master Subsystem.

**Table 6-7. Control Subsystem Flash, ECC, OTP, Boot ROM**

| C DMA ACCESS <sup>(1)</sup> | C ADDRESS (x16 ALIGNED) <sup>(1)</sup> | CONTROL SUBSYSTEM FLASH, ECC, OTP, BOOT ROM                | SIZE (BYTES) | M ADDRESS (BYTE-ALIGNED) <sup>(2)</sup> | μDMA ACCESS |
|-----------------------------|--|--|--------------|---|-------------|
| no                          | 0010 0000 – 0010 1FFF                  | Sector N (not available for 256KB Flash configuration)     | 16K          |   |             |
| no                          | 0010 2000 – 0010 3FFF                  | Sector M (not available for 256KB Flash configuration)     | 16K          |   |             |
| no                          | 0010 4000 – 0010 5FFF                  | Sector L (not available for 256KB Flash configuration)     | 16K          |   |             |
| no                          | 0010 6000 – 0010 7FFF                  | Sector K (not available for 256KB Flash configuration)     | 16K          |   |             |
| no                          | 0010 8000 – 0010 FFFF                  | Sector J (not available for 256KB Flash configuration)     | 64K          |   |             |
| no                          | 0011 0000 – 0011 7FFF                  | Sector I (not available for 256KB Flash configuration)     | 64K          |   |             |
| no                          | 0011 8000 – 0011 FFFF                  | Sector H (not available for 256KB Flash configuration)     | 64K          |   |             |
| no                          | 0012 0000 – 0012 7FFF                  | Sector G   | 64K          |   |             |
| no                          | 0012 8000 – 0012 FFFF                  | Sector F   | 64K          |   |             |
| no                          | 0013 0000 – 0013 7FFF                  | Sector E   | 64K          |   |             |
| no                          | 0013 8000 – 0013 9FFF                  | Sector D   | 16K          |   |             |
| no                          | 0013 A000 – 0013 BFFF                  | Sector C   | 16K          |   |             |
| no                          | 0013 C000 – 0013 DFFF                  | Sector B   | 16K          |   |             |
| no                          | 0013 E000 – 0013 FFFF                  | Sector A (CSM password in the high address)                | 16K          |   |             |
|                             | 0014 0000 – 001F FFFF                  | Reserved   |              |   |             |
| no                          | 0020 0000 – 0020 7FFF                  | Flash - ECC Bits (1/8 of Flash used = 64KB)                | 64K          |   |             |
|                             | 0020 8000 – 0024 01FF                  | Reserved   |              |   |             |
| no                          | 0024 0200 – 0024 03FF                  | TI one-time programmable (OTP) memory                      | 1K           |   |             |
|                             | 0024 0400 – 002F FFFF                  | Reserved   |              |   |             |
| yes                         | 0030 0000 – 003F 7FFF                  | EPI0 (External Peripheral/Memory Interface) <sup>(3)</sup> | 2G           | 6000 0000 – DFFF FFFF                   | yes         |
| no                          | 003F 8000 – 003F FFFF                  | C28x Boot ROM (64KB)                                       | 64K          |   |             |

(1) The letter "C" refers to the Control Subsystem.

(2) The letter "M" refers to the Master Subsystem.

(3) The Control Subsystem has no direct access to EPI in silicon revision 0 devices.

## 6.1.2 Master Subsystem Memory Map

**Table 6-8. Master Subsystem Flash, ECC, OTP, Boot ROM**

| $\mu$ DMA ACCESS | M ADDRESS<br>(BYTE-ALIGNED) <sup>(1)</sup> | MASTER SUBSYSTEM FLASH, ECC, OTP, BOOT ROM  | SIZE<br>(BYTES) |
|------------------|--|---|-----------------|
| no               | 0000 0000 – 0000 FFFF                      | Boot ROM - Dual-mapped to 0x0100 0000<br>(Both maps access same physical location.) | 64K             |
|                  | 0001 0000 – 001F FFFF                      | Reserved  |                 |
| no               | 0020 0000 – 0020 3FFF                      | Sector N<br>(Zone 1 CSM password in the low address.)                               | 16K             |
| no               | 0020 4000 – 0020 7FFF                      | Sector M  | 16K             |
| no               | 0020 8000 – 0020 BFFF                      | Sector L  | 16K             |
| no               | 0020 C000 – 0020 FFFF                      | Sector K  | 16K             |
| no               | 0021 0000 – 0021 FFFF                      | Sector J  | 64K             |
| no               | 0022 0000 – 0022 FFFF                      | Sector I (not available for 256KB Flash configuration)                              | 64K             |
| no               | 0023 0000 – 0023 FFFF                      | Sector H (not available for 256KB Flash configuration)                              | 64K             |
| no               | 0024 0000 – 0024 FFFF                      | Sector G (not available for 256KB Flash configuration)                              | 64K             |
| no               | 0025 0000 – 0025 FFFF                      | Sector F (not available for 256KB Flash configuration)                              | 64K             |
| no               | 0026 0000 – 0026 FFFF                      | Sector E  | 64K             |
| no               | 0027 0000 – 0027 3FFF                      | Sector D  | 16K             |
| no               | 0027 4000 – 0027 7FFF                      | Sector C  | 16K             |
| no               | 0027 8000 – 0027 BFFF                      | Sector B  | 16K             |
| no               | 0027 C000 – 0027 FFFF                      | Sector A<br>(Zone 2 CSM password in the high address.)                              | 16K             |
|                  | 0028 0000 – 005F FFFF                      | Reserved  |                 |
| no               | 0060 0000 – 0060 FFFF                      | Flash - ECC Bits<br>(1/8 of Flash used = 64KB)                                      | 64K             |
|                  | 0061 0000 – 0068 047F                      | Reserved  |                 |
| no               | 0068 0480 – 0068 07FF                      | TI OTP  | 896             |
| no               | 0068 0800                                  | OTP – Security Lock   | 4               |
|                  | 0068 0804                                  | Reserved  |                 |
|                  | 0068 0808                                  | Reserved  |                 |
| no               | 0068 080C                                  | OTP – Zone 2 Flash Start Address  | 4               |
| no               | 0068 0810                                  | OTP – Ethernet Media Access Controller (EMAC) Address 0                             | 4               |
| no               | 0068 0814                                  | OTP – EMAC Address 1  | 4               |
|                  | 0068 0818                                  | Reserved  |                 |
| no               | 0068 081C                                  | Main Oscillator Clock Frequency   | 4               |
|                  | 0068 0820                                  | Reserved  |                 |
| no               | 0068 0824                                  | Alternate Boot mode Pin Configuration   | 4               |
|                  | 0068 0828                                  | Reserved  |                 |
| no               | 0068 082C                                  | OTP ENTRY POINT   | 4               |
|                  | 0068 0830 – 0070 00FF                      | Reserved  |                 |
| no               | 0070 0100 – 0070 0102                      | OTP – ECC Bits – Application Use<br>(1/8 of OTP used = 3 Bytes)                     | 3               |
|                  | 0070 0103 – 00FF FFFF                      | Reserved  |                 |
| no               | 0100 0000 – 0100 FFFF                      | Boot ROM – Dual-mapped to 0x0000 0000<br>(Both maps access same physical location.) | 64K             |
|                  | 0101 0000 – 03FF FFFF                      | Reserved  |                 |

(1) The letter "M" refers to the Master Subsystem.

**Table 6-8. Master Subsystem Flash, ECC, OTP, Boot ROM (continued)**

| μDMA ACCESS | M ADDRESS (BYTE-ALIGNED) <sup>(1)</sup> | MASTER SUBSYSTEM FLASH, ECC, OTP, BOOT ROM  | SIZE (BYTES) |
|-------------|---|---|--------------|
| no          | 0400 0000 – 07FF FFFF                   | ROM/Flash/OTP/Boot ROM – Mirror-mapped <i>for μCRC</i> . Accessing this area of memory by the μCRC peripheral will cause an access in 0000 0000 – 03FF FFFF memory space.<br>Mirrored boot ROM: 0x0400 0000 – 0x0400 FFFF (Not dual-mapped ROM address)<br>Mirrored Flash bank: 0x0420 0000 – 0x042F FFFF<br>Mirrored Flash OTP: 0x0468 0000 – 0x0468 1FFF<br>(Read cycles from this space cause the μCRC peripheral to continuously update data checksum inside a register, when reading a block of data.) | 64M          |
|             | 0800 0000 – 1FFF FFFF                   | Reserved  |              |

**Table 6-9. Master Subsystem RAMs**

| μDMA ACCESS   | M ADDRESS (BYTE-ALIGNED) <sup>(1)</sup> | MASTER SUBSYSTEM RAMS      | SIZE (BYTES) | C ADDRESS (x16 ALIGNED) <sup>(2)</sup> | C DMA ACCESS <sup>(2)</sup> |
|---------------|---|----------------------------|--------------|--|-----------------------------|
| no            | 2000 0000 – 2000 1FFF                   | C0 RAM (ECC, Secure)       | 8K           |  |                             |
| no            | 2000 2000 – 2000 3FFF                   | C1 RAM (ECC, Secure)       | 8K           |  |                             |
| yes           | 2000 4000 – 2000 5FFF                   | C2 RAM (Parity)            | 8K           |  |                             |
| yes           | 2000 6000 – 2000 7FFF                   | C3 RAM (Parity)            | 8K           |  |                             |
| yes           | 2000 8000 – 2000 9FFF                   | S0 RAM (Parity, Shared)    | 8K           | 0000 C000 – 0000 CFFF                  | yes                         |
| yes           | 2000 A000 – 2000 BFFF                   | S1 RAM (Parity, Shared)    | 8K           | 0000 D000 – 0000 DFFF                  | yes                         |
| yes           | 2000 C000 – 2000 DFFF                   | S2 RAM (Parity, Shared)    | 8K           | 0000 E000 – 0000 EFFF                  | yes                         |
| yes           | 2000 E000 – 2000 FFFF                   | S3 RAM (Parity, Shared)    | 8K           | 0000 F000 – 0000 FFFF                  | yes                         |
| yes           | 2001 0000 – 2001 1FFF                   | S4 RAM (Parity, Shared)    | 8K           | 0001 0000 – 0001 0FFF                  | yes                         |
| yes           | 2001 2000 – 2001 3FFF                   | S5 RAM (Parity, Shared)    | 8K           | 0001 1000 – 0001 1FFF                  | yes                         |
| yes           | 2001 4000 – 2001 5FFF                   | S6 RAM (Parity, Shared)    | 8K           | 0001 2000 – 0001 2FFF                  | yes                         |
| yes           | 2001 6000 – 2001 7FFF                   | S7 RAM (Parity, Shared)    | 8K           | 0001 3000 – 0001 3FFF                  | yes                         |
|               | 2001 8000 – 2007 EFFF                   | Reserved                   |              |  |                             |
| yes read only | 2007 F000 – 2007 F7FF                   | CtoM MSG RAM (Parity)      | 2K           | 0003 F800 – 0003 FBFF                  | yes                         |
| yes           | 2007 F800 – 2007 FFFF                   | MtoC MSG RAM (Parity)      | 2K           | 0003 FC00 – 0003 FFFF                  | yes read only               |
| no            | 2008 0000 – 2008 1FFF                   | C0 RAM - ECC Bits          | 8K           |  |                             |
| no            | 2008 2000 – 2008 3FFF                   | C1 RAM - ECC Bits          | 8K           |  |                             |
| no            | 2008 4000 – 2008 5FFF                   | C2 RAM - Parity Bits       | 8K           |  |                             |
| no            | 2008 6000 – 2008 7FFF                   | C3 RAM - Parity Bits       | 8K           |  |                             |
| no            | 2008 8000 – 2008 9FFF                   | S0 RAM - Parity Bits       | 8K           | 0004 C000 – 0004 CFFF                  | no                          |
| no            | 2008 A000 – 2008 BFFF                   | S1 RAM - Parity Bits       | 8K           | 0004 D000 – 0004 DFFF                  | no                          |
| no            | 2008 C000 – 2008 DFFF                   | S2 RAM - Parity Bits       | 8K           | 0004 E000 – 0004 EFFF                  | no                          |
| no            | 2008 E000 – 2008 FFFF                   | S3 RAM - Parity Bits       | 8K           | 0004 F000 – 0004 FFFF                  | no                          |
| no            | 2009 0000 – 2009 1FFF                   | S4 RAM - Parity Bits       | 8K           | 0005 0000 – 0005 0FFF                  | no                          |
| no            | 2009 2000 – 2009 3FFF                   | S5 RAM - Parity Bits       | 8K           | 0005 1000 – 0005 1FFF                  | no                          |
| no            | 2009 4000 – 2009 5FFF                   | S6 RAM - Parity Bits       | 8K           | 0005 2000 – 0005 2FFF                  | no                          |
| no            | 2009 6000 – 2009 7FFF                   | S7 RAM - Parity Bits       | 8K           | 0005 3000 – 0005 3FFF                  | no                          |
|               | 2009 8000 – 200F EFFF                   | Reserved                   |              |  |                             |
| no            | 200F F000 – 200F F7FF                   | CtoM MSG RAM - Parity Bits | 2K           | 0007 F800 – 0007 FBFF                  | no                          |
| no            | 200F F800 – 200F FFFF                   | MtoC MSG RAM - Parity Bits | 2K           | 0007 FC00 – 0007 FFFF                  | no                          |
|               | 2010 0000 – 21FF FFFF                   | Reserved                   |              |  |                             |

(1) The letter "M" refers to the Master Subsystem.

(2) The letter "C" refers to the Control Subsystem.

**Table 6-9. Master Subsystem RAMs (continued)**

| μDMA ACCESS | M ADDRESS (BYTE-ALIGNED) <sup>(1)</sup> | MASTER SUBSYSTEM RAMS  | SIZE (BYTES) | C ADDRESS (x16 ALIGNED) <sup>(2)</sup> | C DMA ACCESS <sup>(2)</sup> |
|-------------|---|--|--------------|--|-----------------------------|
| yes         | 2200 0000 – 23FF FFFF                   | Bit Banded RAM Zone (Dedicated address for each RAM bit of Cortex-M3 RAM blocks above)   | 32M          |  |                             |
| yes         | 2400 0000 – 27FF FFFF                   | All RAM Spaces – Mirror-Mapped <b>for μCRC</b> . Accessing this memory by the μCRC peripheral will cause an access to 2000 0000 – 23FF FFFF memory space. (Read cycles from this space cause the μCRC peripheral to continuously update data checksum inside a register when reading a block of data.) | 64M          |  |                             |
|             | 2800 0000 – 3FFF FFFF                   | Reserved   |              |  |                             |

**Table 6-10. Master Subsystem Peripherals**

| μDMA ACCESS | M ADDRESS (BYTE-ALIGNED) <sup>(1)</sup> | MASTER SUBSYSTEM PERIPHERALS           | SIZE (BYTES) | C ADDRESS (x16 ALIGNED) <sup>(2)</sup> | C DMA ACCESS <sup>(2)</sup> |
|-------------|---|--|--------------|--|-----------------------------|
| yes         | 4000 0000 – 4000 0FFF                   | Watchdog Timer 0 Registers             | 4K           |  |                             |
| yes         | 4000 1000 – 4000 1FFF                   | Watchdog Timer 1 Registers             | 4K           |  |                             |
|             | 4000 2000 – 4000 3FFF                   | Reserved                               |              |  |                             |
| yes         | 4000 4000 – 4000 4FFF                   | M GPIO Port A (APB Bus) <sup>(1)</sup> | 4K           |  |                             |
| yes         | 4000 5000 – 4000 5FFF                   | M GPIO Port B (APB Bus) <sup>(1)</sup> | 4K           |  |                             |
| yes         | 4000 6000 – 4000 6FFF                   | M GPIO Port C (APB Bus) <sup>(1)</sup> | 4K           |  |                             |
| yes         | 4000 7000 – 4000 7FFF                   | M GPIO Port D (APB Bus) <sup>(1)</sup> | 4K           |  |                             |
| yes         | 4000 8000 – 4000 8FFF                   | SSI0                                   | 4K           |  |                             |
| yes         | 4000 9000 – 4000 9FFF                   | SSI1                                   | 4K           |  |                             |
| yes         | 4000 A000 – 4000 AFFF                   | SSI2                                   | 4K           |  |                             |
| yes         | 4000 B000 – 4000 BFFF                   | SSI3                                   | 4K           |  |                             |
| yes         | 4000 C000 – 4000 CFFF                   | UART0                                  | 4K           |  |                             |
| yes         | 4000 D000 – 4000 DFFF                   | UART1                                  | 4K           |  |                             |
| yes         | 4000 E000 – 4000 EFFF                   | UART2                                  | 4K           |  |                             |
| yes         | 4000 F000 – 4000 FFFF                   | UART3                                  | 4K           |  |                             |
| yes         | 4001 0000 – 4001 0FFF                   | UART4                                  | 4K           |  |                             |
|             | 4001 1000 – 4001 FFFF                   | Reserved                               |              |  |                             |
| no          | 4002 0000 – 4002 07FF                   | I2C0 Master                            | 2K           |  |                             |
| no          | 4002 0800 – 4002 0FFF                   | I2C0 Slave                             | 2K           |  |                             |
| no          | 4002 1000 – 4002 17FF                   | I2C1 Master                            | 2K           |  |                             |
| no          | 4002 1800 – 4002 1FFF                   | I2C1 Slave                             | 2K           |  |                             |
|             | 4002 2000 – 4002 3FFF                   | Reserved                               |              |  |                             |
| yes         | 4002 4000 – 4002 4FFF                   | M GPIO Port E (APB Bus) <sup>(1)</sup> | 4K           |  |                             |
| yes         | 4002 5000 – 4002 5FFF                   | M GPIO Port F (APB Bus) <sup>(1)</sup> | 4K           |  |                             |
| yes         | 4002 6000 – 4002 6FFF                   | M GPIO Port G (APB Bus) <sup>(1)</sup> | 4K           |  |                             |
| yes         | 4002 7000 – 4002 7FFF                   | M GPIO Port H (APB Bus) <sup>(1)</sup> | 4K           |  |                             |
|             | 4002 8000 – 4002 FFFF                   | Reserved                               |              |  |                             |
| yes         | 4003 0000 – 4003 0FFF                   | GP Timer 0                             | 4K           |  |                             |

(1) The letter "M" refers to the Master Subsystem.

(2) The letter "C" refers to the Control Subsystem.

**Table 6-10. Master Subsystem Peripherals (continued)**

| <b>μDMA ACCESS</b> | <b>M ADDRESS (BYTE-ALIGNED)<sup>(1)</sup></b> | <b>MASTER SUBSYSTEM PERIPHERALS</b>            | <b>SIZE (BYTES)</b> | <b>C ADDRESS (x16 ALIGNED)<sup>(2)</sup></b> | <b>C DMA ACCESS<sup>(2)</sup></b> |
|--------------------|---|--|---------------------|--|-----------------------------------|
| yes                | 4003 1000 – 4003 1FFF                         | GP Timer 1                                     | 4K                  |  |                                   |
| yes                | 4003 2000 – 4003 2FFF                         | GP Timer 2                                     | 4K                  |  |                                   |
| yes                | 4003 3000 – 4003 3FFF                         | GP Timer 3                                     | 4K                  |  |                                   |
|                    | 4003 4000 – 4003 CFFF                         | Reserved                                       |                     |  |                                   |
| yes                | 4003 D000 – 4003 DFFF                         | M GPIO Port J (APB Bus) <sup>(1)</sup>         | 4K                  |  |                                   |
|                    | 4003 E000 – 4003 FFFF                         | Reserved                                       |                     |  |                                   |
| yes                | 4004 8000 – 4004 8FFF                         | ENET MAC0                                      | 4K                  |  |                                   |
|                    | 4004 9000 – 4004 FFFF                         | Reserved                                       |                     |  |                                   |
| yes                | 4005 0000 – 4005 0FFF                         | USB MAC0                                       | 4K                  |  |                                   |
|                    | 4005 1000 – 4005 7FFF                         | Reserved                                       |                     |  |                                   |
| yes                | 4005 8000 – 4005 8FFF                         | M GPIO Port A (AHB Bus) <sup>(1)</sup>         | 4K                  |  |                                   |
| yes                | 4005 9000 – 4005 9FFF                         | M GPIO Port B (AHB Bus) <sup>(1)</sup>         | 4K                  |  |                                   |
| yes                | 4005 A000 – 4005 AFFF                         | M GPIO Port C (AHB Bus) <sup>(1)</sup>         | 4K                  |  |                                   |
| yes                | 4005 B000 – 4005 BFFF                         | M GPIO Port D (AHB Bus) <sup>(1)</sup>         | 4K                  |  |                                   |
| yes                | 4005 C000 – 4005 CFFF                         | M GPIO Port E (AHB Bus) <sup>(1)</sup>         | 4K                  |  |                                   |
| yes                | 4005 D000 – 4005 DFFF                         | M GPIO Port F (AHB Bus) <sup>(1)</sup>         | 4K                  |  |                                   |
| yes                | 4005 E000 – 4005 EFFF                         | M GPIO Port G (AHB Bus) <sup>(1)</sup>         | 4K                  |  |                                   |
| yes                | 4005 F000 – 4005 FFFF                         | M GPIO Port H (AHB Bus) <sup>(1)</sup>         | 4K                  |  |                                   |
| yes                | 4006 0000 – 4006 0FFF                         | M GPIO Port J (AHB Bus) <sup>(1)</sup>         | 4K                  |  |                                   |
|                    | 4006 1000 – 4006 FFFF                         | Reserved                                       |                     |  |                                   |
| no                 | 4007 0000 – 4007 3FFF                         | CAN0   | 16K                 |  |                                   |
| no                 | 4007 4000 – 4007 7FFF                         | CAN1   | 16K                 |  |                                   |
|                    | 4007 8000 – 400C FFFF                         | Reserved                                       |                     |  |                                   |
| no                 | 400D 0000 – 400D 0FFF                         | EPI0 (Registers only)                          | 4K                  |  |                                   |
|                    | 400D 1000 – 400F 9FFF                         | Reserved                                       |                     |  |                                   |
| no                 | 400F A000 – 400F A303                         | M Flash Control Registers <sup>(1)</sup>       | 772                 |  |                                   |
|                    | 400F A304 – 400F A5FF                         | Reserved                                       |                     |  |                                   |
| no                 | 400F A600 – 400F A647                         | M Flash ECC Error Log Registers <sup>(1)</sup> | 72                  |  |                                   |
|                    | 400F A648 – 400F AFFF                         | Reserved                                       |                     |  |                                   |
| no                 | 400F B000 – 400F B1FF                         | Reserved                                       |                     |  |                                   |
| no                 | 400F B200 – 400F B2FF                         | RAM Configuration Registers                    | 256                 | 0000 4900 – 0000 497F                        | no                                |
| no                 | 400F B300 – 400F B3FF                         | RAM ECC/Parity/Access Error Log Registers      | 256                 | 0000 4A00 – 0000 4A7F                        | no                                |
| no                 | 400F B400 – 400F B5FF                         | M CSM Registers <sup>(1)</sup>                 | 512                 |  |                                   |
| no                 | 400F B600 – 400F B67F                         | μCRC   | 128                 |  |                                   |
|                    | 400F B680 – 400F B6FF                         | Reserved                                       |                     |  |                                   |
| no                 | 400F B700 – 400F B77F                         | CtoM and MtoC IPC Registers                    | 128                 | 0000 4E00 – 0000 4E3F                        | no                                |
|                    | 400F B780 – 400F B7FF                         | Reserved                                       |                     |  |                                   |
| no                 | 400F B800 – 400F B87F                         | M Clock Control Registers <sup>(1)</sup>       | 128                 | 0000 4400 – 0000 443F                        | no                                |
| no                 | 400F B880 – 400F B8BF                         | M LPM Control Registers <sup>(1)</sup>         | 64                  |  |                                   |
| no                 | 400F B8C0 – 400F B8FF                         | M Reset Control Registers <sup>(1)</sup>       | 64                  |  |                                   |
| no                 | 400F B900 – 400F B93F                         | Device Configuration Registers                 | 64                  | 0000 0880 – 0000 0890<br>(Read Only)         |                                   |
|                    | 400F B940 – 400F B97F                         | Reserved                                       |                     |  |                                   |
| no                 | 400F B980 – 400F B9FF                         | M Write Protect Registers <sup>(1)</sup>       | 128                 |  |                                   |
| no                 | 400F BA00 – 400F BA7F                         | M NMI Registers <sup>(1)</sup>                 | 128                 |  |                                   |

**Table 6-10. Master Subsystem Peripherals (continued)**

| μDMA ACCESS | M ADDRESS (BYTE-ALIGNED) <sup>(1)</sup> | MASTER SUBSYSTEM PERIPHERALS   | SIZE (BYTES) | C ADDRESS (x16 ALIGNED) <sup>(2)</sup> | C DMA ACCESS <sup>(2)</sup> |
|-------------|---|--|--------------|--|-----------------------------|
|             | 400F BA80 – 400F BAFF                   | Reserved   |              |  |                             |
| no          | 400F BB00 – 400F BBFF                   | Reserved   |              |  |                             |
|             | 400F BC00 – 400F EFFF                   | Reserved   |              |  |                             |
| no          | 400F F000 – 400F FFFF                   | μDMA Registers   | 4K           |  |                             |
|             | 4010 0000 – 41FF FFFF                   | Reserved   |              |  |                             |
| yes         | 4200 0000 – 43FF FFFF                   | Bit Banded Peripheral Zone (Dedicated address for each register bit of Cortex-M3 peripherals above.) | 32M          |  |                             |
|             | 4400 0000 – 4FFF FFFF                   | Reserved   |              |  |                             |

**Table 6-11. Master Subsystem Analog and EPI**

| μDMA ACCESS | M ADDRESS (BYTE-ALIGNED) <sup>(1)</sup> | MASTER SUBSYSTEM ANALOG AND EPI             | SIZE (BYTES) | C ADDRESS (x16 ALIGNED) <sup>(2)</sup> | C DMA ACCESS <sup>(2)</sup> |
|-------------|---|---|--------------|--|-----------------------------|
|             | 5000 0000 – 5000 15FF                   | Reserved                                    |              |  |                             |
| yes         | 5000 1600 – 5000 161F                   | ADC1 Result Registers                       | 32           |  |                             |
|             | 5000 1620 – 5000 167F                   | Reserved                                    |              |  |                             |
| yes         | 5000 1680 – 5000 169F                   | ADC2 Result Registers                       | 32           |  |                             |
|             | 5000 16A0 – 5FFF FFFF                   | Reserved                                    |              |  |                             |
| yes         | 6000 0000 – DFFF FFFF                   | EPI0 (External Peripheral/Memory Interface) | 2G           | 0030 0000 – 003F 7FFF <sup>(3)</sup>   | yes                         |

- (1) The letter "M" refers to the Master Subsystem.
- (2) The letter "C" refers to the Control Subsystem.
- (3) The Control Subsystem has no direct access to EPI in silicon revision 0 devices.

**Table 6-12. Cortex-M3 Private Bus**

| μDMA ACCESS | Cortex-M3 ADDRESS (BYTE-ALIGNED) | Cortex-M3 PRIVATE BUS                       | SIZE (BYTES) |
|-------------|----------------------------------|---|--------------|
| no          | E000 0000 – E000 0FFF            | ITM (Instrumentation Trace Macrocell)       | 4K           |
| no          | E000 1000 – E000 1FFF            | DWT (Data Watchpoint and Trace)             | 4K           |
| no          | E000 2000 – E000 2FFF            | FPB (Flash Patch and Breakpoint)            | 4K           |
|             | E000 3000 – E000 E007            | Reserved                                    |              |
| no          | E000 E008 – E000 E00F            | System Control Block                        | 8            |
| no          | E000 E010 – E000 E01F            | System Timer                                | 16           |
|             | E000 E020 – E000 E0FF            | Reserved                                    |              |
| no          | E000 E100 – E000 E4EF            | Nested Vectored Interrupt Controller (NVIC) | 1008         |
|             | E000 E4F0 – E000 ECFF            | Reserved                                    |              |
| no          | E000 ED00 – E000 ED3F            | System Control Block                        | 64           |
|             | E000 ED40 – E000 ED8F            | Reserved                                    |              |
| no          | E000 ED90 – E000 EDB8            | Memory Protection Unit                      | 41           |
|             | E000 EDB9 – E000 EEEF            | Reserved                                    |              |
| no          | E000 EF00 – E000 EF03            | Nested Vectored Interrupt Controller        | 4            |
|             | E000 EF04 – FFFF FFFF            | Reserved                                    |              |

**NOTE**

MPU is not available on silicon revision 0 devices.

## 6.2 Identification

**Table 6-13. Device Identification Registers**

| NAME                    | C ADDRESS<br>(x16 ALIGNED) <sup>(1)</sup> | M ADDRESS<br>(BYTE ALIGNED) <sup>(2)</sup> | DESCRIPTION  |                         |                  |             |      |             |      |             |      |             |      |             |      |             |      |
|-------------------------|---|--|--|-------------------------|------------------|-------------|------|-------------|------|-------------|------|-------------|------|-------------|------|-------------|------|
| DID0.REVID              |   | 400F E000 – 400F E001                      | Device Identification 0 Register - Revision_ID   |                         |                  |             |      |             |      |             |      |             |      |             |      |             |      |
| REVID                   | 0x0000 0883                               |  | REVID - Current Revision ID of device<br><table style="margin-left: 40px;"> <thead> <tr> <th>Silicon Revision Number</th> <th>REVID</th> </tr> </thead> <tbody> <tr> <td>0</td> <td>0</td> </tr> <tr> <td>A</td> <td>1</td> </tr> <tr> <td>B</td> <td>1</td> </tr> <tr> <td>E</td> <td>5</td> </tr> </tbody> </table>  | Silicon Revision Number | REVID            | 0           | 0    | A           | 1    | B           | 1    | E           | 5    |             |      |             |      |
| Silicon Revision Number | REVID                                     |  |  |                         |                  |             |      |             |      |             |      |             |      |             |      |             |      |
| 0                       | 0   |  |  |                         |                  |             |      |             |      |             |      |             |      |             |      |             |      |
| A                       | 1   |  |  |                         |                  |             |      |             |      |             |      |             |      |             |      |             |      |
| B                       | 1   |  |  |                         |                  |             |      |             |      |             |      |             |      |             |      |             |      |
| E                       | 5   |  |  |                         |                  |             |      |             |      |             |      |             |      |             |      |             |      |
| DID1.PARTNO             |   | 400F E006                                  | Device Identification 1 Register - Part_Number   |                         |                  |             |      |             |      |             |      |             |      |             |      |             |      |
| PARTID.PARTNO           | 0x0000 0882                               |  | C28x Device PARTID Register - Device Part Number<br><table style="margin-left: 40px;"> <thead> <tr> <th>Device</th> <th>PARTNO (M3/C28x)</th> </tr> </thead> <tbody> <tr> <td>F28M35E20B1</td> <td>0x49</td> </tr> <tr> <td>F28M35M52C1</td> <td>0x4A</td> </tr> <tr> <td>F28M35M22C1</td> <td>0x50</td> </tr> <tr> <td>F28M35M20B1</td> <td>0x53</td> </tr> <tr> <td>F28M35H52C1</td> <td>0x54</td> </tr> <tr> <td>F28M35H22C1</td> <td>0x5A</td> </tr> </tbody> </table> | Device                  | PARTNO (M3/C28x) | F28M35E20B1 | 0x49 | F28M35M52C1 | 0x4A | F28M35M22C1 | 0x50 | F28M35M20B1 | 0x53 | F28M35H52C1 | 0x54 | F28M35H22C1 | 0x5A |
| Device                  | PARTNO (M3/C28x)                          |  |  |                         |                  |             |      |             |      |             |      |             |      |             |      |             |      |
| F28M35E20B1             | 0x49                                      |  |  |                         |                  |             |      |             |      |             |      |             |      |             |      |             |      |
| F28M35M52C1             | 0x4A                                      |  |  |                         |                  |             |      |             |      |             |      |             |      |             |      |             |      |
| F28M35M22C1             | 0x50                                      |  |  |                         |                  |             |      |             |      |             |      |             |      |             |      |             |      |
| F28M35M20B1             | 0x53                                      |  |  |                         |                  |             |      |             |      |             |      |             |      |             |      |             |      |
| F28M35H52C1             | 0x54                                      |  |  |                         |                  |             |      |             |      |             |      |             |      |             |      |             |      |
| F28M35H22C1             | 0x5A                                      |  |  |                         |                  |             |      |             |      |             |      |             |      |             |      |             |      |

(1) The letter "C" refers to the Control Subsystem.

(2) The letter "M" refers to the Master Subsystem.

## 6.3 Master Subsystem

The Master Subsystem includes the Cortex-M3 CPU,  $\mu$ DMA, Nested Vectored Interrupt Controller (NVIC), Cortex-M3 Peripherals, and Local Memory. Additionally, the Cortex-M3 CPU and  $\mu$ DMA can access the Control Subsystem through Shared Resources: IPC (CPU only), Message RAM, and Shared RAM; and read ADC Result Registers through the Analog Common Interface Bus. The Master Subsystem can also receive events from the NMI block and send events to the Resets block.

Figure 6-1 shows the Master Subsystem.

### 6.3.1 Cortex-M3 CPU

The 32-bit Cortex-M3 processor offers high performance, fast interrupt handling, and access to a variety of communication peripherals (including Ethernet and USB). The Cortex-M3 features a Memory Protection Unit (MPU) to provide a privileged mode for protected operating system functionality. A bus bridge adjacent to the MPU can route program instructions and data on the I-CODE and D-CODE buses that connect to the Boot ROM and Flash. Other data is typically routed through the Cortex-M3 System Bus connected to the local RAMs. The System Bus also goes to the Shared Resources block (also accessible by the Control Subsystem) and to the Analog Subsystem through the ACIB. Another bus bridge allows bus cycles from both the Cortex-M3 System Bus and those of the  $\mu$ DMA bus to access the Master Subsystem peripherals (through the APB bus or the AHP bus).

Most of the interrupts to the Cortex-M3 CPU come from the NVIC, which manages the interrupt requests from peripherals and assigns handling priorities. There are also several exceptions generated by Cortex-M3 CPU that can return to the Cortex-M3 as interrupts after being prioritized with other requests inside the NVIC. In addition to programmable priority interrupts, there are also three levels of fixed-priority interrupts of which the highest priority, level-3, is given to M3PORRST and M3SYSRST resets from the Resets block. The next highest priority, level-2, is assigned to the M3NMIINT, which originates from the NMI block. The M3HRDFLT (Hard Fault) interrupt is assigned to level-1 priority, and this interrupt is caused by one of the error condition exceptions (Memory Management, Bus Fault, Usage Fault) escalating to Hard Fault because they are not enabled or not properly serviced.

The Cortex-M3 CPU has two low-power modes: Sleep and Deep Sleep.



### 6.3.2 Cortex-M3 DMA and NVIC

The Cortex-M3 direct memory access ( $\mu$ DMA) module provides a hardware method of transferring data between peripherals, between memory, and between peripherals and memory without intervention from the Cortex-M3 CPU. The NVIC manages and prioritizes interrupt handling for the Cortex-M3 CPU.

The Cortex-M3 peripherals use REQ/DONE handshaking to coordinate data transfer requests with the  $\mu$ DMA. If a DMA channel is enabled for a given peripheral, REQ/DONE from the peripheral will trigger the data transfer, following which an IRQ request may be sent from the  $\mu$ DMA to the NVIC to announce to the Cortex-M3 that the transfer has completed. If a DMA channel is not enabled for a given peripheral, REQ/DONE will directly drive IRQ to the NVIC so that the Cortex-M3 CPU can transfer the data. For those peripherals that are not supported by the  $\mu$ DMA, IRQs are supplied directly to the NVIC, bypassing the DMA. This case is true for both Watchdogs, CANs, I2Cs, and the Analog-to-Digital Converters sending ADCINT[8:1] interrupts from the Analog Subsystem. The NMI Watchdog does not send any events to the  $\mu$ DMA or the NVIC (only to the Resets block).

### 6.3.3 Cortex-M3 Interrupts

Table 6-14 shows all interrupt assignments for the Cortex-M3 processor. Most interrupts (16–107) are associated with interrupt requests from Cortex-M3 peripherals. The first 15 interrupts (1–15) are processor exceptions generated by the Cortex-M3 core itself. These processor exceptions are detailed in Table 6-15.

**Table 6-14. Interrupts from NVIC to Cortex-M3**

| INTERRUPT NUMBER<br>(BIT IN INTERRUPT<br>REGISTERS) | VECTOR NUMBER | VECTOR ADDRESS OR<br>OFFSET | DESCRIPTION             |
|---|---------------|-----------------------------|-------------------------|
| –   | 0–15          | 0x0000.0000–0x0000.003C     | Processor exceptions    |
| 0   | 16            | 0x0000.0040                 | GPIO Port A             |
| 1   | 17            | 0x0000.0044                 | GPIO Port B             |
| 2   | 18            | 0x0000.0048                 | GPIO Port C             |
| 3   | 19            | 0x0000.004C                 | GPIO Port D             |
| 4   | 20            | 0x0000.0050                 | GPIO Port E             |
| 5   | 21            | 0x0000.0054                 | UART0                   |
| 6   | 22            | 0x0000.0058                 | UART1                   |
| 7   | 23            | 0x0000.005C                 | SSI0                    |
| 8   | 24            | 0x0000.0060                 | I2C0                    |
| 9–17  | 25–33         | –                           | Reserved                |
| 18  | 34            | 0x0000.0088                 | Watchdog Timers 0 and 1 |
| 19  | 35            | 0x0000.008C                 | Timer 0A                |
| 20  | 36            | 0x0000.0090                 | Timer 0B                |
| 21  | 37            | 0x0000.0094                 | Timer 1A                |
| 22  | 38            | 0x0000.0098                 | Timer 1B                |
| 23  | 39            | 0x0000.009C                 | Timer 2A                |
| 24  | 40            | 0x0000.00A0                 | Timer 2B                |
| 25–27   | 41–43         | –                           | Reserved                |
| 28  | 44            | 0x0000.00B0                 | System Control          |
| 29  | 45            | 0x0000.00B4                 | Reserved                |
| 30  | 46            | 0x0000.00B8                 | GPIO Port F             |
| 31  | 47            | 0x0000.00BC                 | GPIO Port G             |
| 32  | 48            | 0x0000.00C0                 | GPIO Port H             |
| 33  | 49            | 0x0000.00C4                 | UART2                   |
| 34  | 50            | 0x0000.00C8                 | SSI1                    |
| 35  | 51            | 0x0000.00CC                 | Timer 3A                |

**Table 6-14. Interrupts from NVIC to Cortex-M3 (continued)**

| INTERRUPT NUMBER<br>(BIT IN INTERRUPT<br>REGISTERS) | VECTOR NUMBER | VECTOR ADDRESS OR<br>OFFSET | DESCRIPTION                  |
|---|---------------|-----------------------------|------------------------------|
| 36  | 52            | 0x0000.00D0                 | Timer 3B                     |
| 37  | 53            | 0x0000.00D4                 | I2C1                         |
| 38–41   | 54–57         | –                           | Reserved                     |
| 42  | 58            | 0x0000.00E8                 | Ethernet Controller          |
| 44  | 60            | 0x0000.00F0                 | USB                          |
| 45  | 61            | –                           | Reserved                     |
| 46  | 62            | 0x0000.00F8                 | μDMA Software                |
| 47  | 63            | 0x0000.00FC                 | μDMA Error                   |
| 48–52   | 64–68         | –                           | Reserved                     |
| 53  | 69            | 0x0000.0114                 | EPI                          |
| 54  | 70            | 0x0000.0118                 | GPIO Port J                  |
| 55–56   | 71–72         | –                           | Reserved                     |
| 57  | 73            | 0x0000.0124                 | SSI 2                        |
| 58  | 74            | 0x0000.0128                 | SSI 3                        |
| 59  | 75            | 0x0000.012C                 | UART3                        |
| 60  | 76            | 0x0000.0130                 | UART4                        |
| 61–63   | 77–79         | –                           | Reserved                     |
| 64  | 80            | 0x0000.0140                 | CAN0 INTO                    |
| 65  | 81            | 0x0000.0144                 | CAN0 INT1                    |
| 66  | 82            | 0x0000.0148                 | CAN1 INTO                    |
| 67  | 83            | 0x0000.014C                 | CAN1 INT1                    |
| 68–71   | 84–87         | –                           | Reserved                     |
| 72  | 88            | 0x0000.0160                 | ADCINT1                      |
| 73  | 89            | 0x0000.0164                 | ADCINT2                      |
| 74  | 90            | 0x0000.0168                 | ADCINT3                      |
| 75  | 91            | 0x0000.016C                 | ADCINT4                      |
| 76  | 92            | 0x0000.0170                 | ADCINT5                      |
| 77  | 93            | 0x0000.0174                 | ADCINT6                      |
| 78  | 94            | 0x0000.0178                 | ADCINT7                      |
| 79  | 95            | 0x0000.017C                 | ADCINT8                      |
| 80  | 96            | 0x0000.0180                 | CTOMIPC1                     |
| 81  | 97            | 0x0000.0184                 | CTOMIPC2                     |
| 82  | 98            | 0x0000.0188                 | CTOMIPC3                     |
| 83  | 99            | 0x0000.018C                 | CTOMIPC4                     |
| 84–87   | 100–103       | –                           | Reserved                     |
| 88  | 104           | 0x0000.01A0                 | RAM Single Error             |
| 89  | 105           | 0x0000.01A4                 | System / USB PLL Out of Lock |
| 90  | 106           | 0x0000.01A8                 | M3 Flash Single Error        |
| 91  | 107           | 0x0000.01AC                 | Reserved                     |
| 92–133  | 108–149       | –                           | Reserved                     |

**Table 6-15. Exceptions from Cortex-M3 Core to NVIC**

| EXCEPTION TYPE              | PRIORITY <sup>(1)</sup>     | VECTOR NUMBER | VECTOR ADDRESS OR OFFSET <sup>(2)</sup> | ACTIVATION  |
|-----------------------------|-----------------------------|---------------|---|---|
| –                           | –                           | 0             | 0x0000.0000                             | Stack top is loaded from the first entry of the vector table on reset.  |
| Reset                       | –3 (highest)                | 1             | 0x0000.0004                             | Asynchronous  |
| Nonmaskable Interrupt (NMI) | –2                          | 2             | 0x0000.0008                             | Asynchronous<br>On Concerto devices activated by clock fail condition, C28 PIE error, external M3GPIO NMI input signal, and C28 NMI WD time-out reset.          |
| Hard Fault                  | –1                          | 3             | 0x0000.000C                             | –   |
| Memory Management           | programmable <sup>(3)</sup> | 4             | 0x0000.0010                             | Synchronous   |
| Bus Fault                   | programmable <sup>(3)</sup> | 5             | 0x0000.0014                             | Synchronous when precise and asynchronous when imprecise.<br>On Concerto devices activated by memory access errors and RAM and flash uncorrectable data errors. |
| Usage Fault                 | programmable <sup>(3)</sup> | 6             | 0x0000.0018                             | Synchronous   |
| –                           | –                           | 7–10          | –                                       | Reserved  |
| SVCall                      | programmable <sup>(3)</sup> | 11            | 0x0000.002C                             | Synchronous   |
| Debug Monitor               | programmable <sup>(3)</sup> | 12            | 0x0000.0030                             | Synchronous   |
| –                           | –                           | 13            | –                                       | Reserved  |
| PendSV                      | programmable <sup>(3)</sup> | 14            | 0x0000.0038                             | Asynchronous  |
| SysTick                     | programmable <sup>(3)</sup> | 15            | 0x0000.003C                             | Asynchronous  |
| Interrupts                  | programmable <sup>(4)</sup> | 16 and above  | 0x0000.0040 and above                   | Asynchronous  |

(1) 0 is the default priority for all the programmable priorities

(2) See the "Vector Table" subsection of the "Exception Model" section in the *Cortex-M3 Processor* chapter of the [Concerto F28M35x Technical Reference Manual](#).

(3) See SYSPRI1 in the *Cortex-M3 Peripherals* chapter of the [Concerto F28M35x Technical Reference Manual](#).

(4) See PRIn registers in the *Cortex-M3 Peripherals* chapter of the [Concerto F28M35x Technical Reference Manual](#).

### 6.3.4 Cortex-M3 Vector Table

Each peripheral interrupt of [Table 6-14](#) is assigned an address offset containing the location of the peripheral interrupt handler (relative to the vector table base) for that particular interrupt (vector numbers 16–107).

Similarly, each exception interrupt of [Table 6-15](#) (including Reset) is also assigned an address offset containing the location of the exception interrupt handler (relative to the vector table base) for that particular interrupt (vector numbers 1–15).

In addition to interrupt vectors, the vector table also contains the initial stack pointer value at table location 0.

Following system reset, the vector table base is fixed at address 0x0000.0000. Privileged software can write to the Vector Table Offset (VTABLE) register to relocate the vector table start address to a different memory location, in the range 0x0000 0200 to 0x3FFF FE00. When configuring the VTABLE register, the offset must be aligned on a 512-byte boundary.

### 6.3.5 Cortex-M3 Local Peripherals

The Cortex-M3 local peripherals include two Watchdogs, an NMI Watchdog, four General-Purpose Timers, four SSI peripherals, two CAN peripherals, five UARTs, two I2C peripherals, Ethernet, USB + PHY, EPI, and  $\mu$ CRC (Cyclic Redundancy Check). The USB and EPI are accessible through the AHB Bus (Advanced High-Performance Bus). The EPI peripheral is also accessible from the Control Subsystem. The remaining peripherals are accessible through the APB Bus (Advanced Peripheral Bus). The APB and AHB bus cycles originate from the CPU System Bus or the  $\mu$ DMA Bus through a bus bridge.

While the Cortex-M3 CPU has access to all the peripherals, the  $\mu$ DMA has access to most, with the exception of the  $\mu$ CRC, Watchdogs, NMI Watchdog, CAN peripherals, and the I2C peripheral. The Cortex-M3 peripherals connect to the Concerto device pins through GPIO\_MUX1. Most of the peripherals also generate event signals for the  $\mu$ DMA and the NVIC. The Watchdogs receive M3SWRST from the NVIC (triggered by software) and send M3WDRST[1:0] reset requests to the Reset block. The NMI Watchdog receives the M3NMI event from the NMI block and sends the M3NMIRST request to the Resets block.

See [Section 5.11](#) for more information on the Cortex-M3 peripherals.

### 6.3.6 Cortex-M3 Local Memory

The Local Memory includes Boot ROM; Secure Flash with ECC; Secure C0/C1 RAM with ECC; and C2/C3 RAM with Parity Error Checking. The Boot ROM and Flash are both accessible through the I-CODE and D-CODE Buses. Flash registers can also be accessed by the Cortex-M3 CPU through the APB Bus. All Local Memory is accessible from the Cortex-M3 CPU; the C2/C3 RAM is also accessible by the  $\mu$ DMA.

Two types of error correction events can be generated during access of the Local Memory: uncorrectable errors and single errors. The uncorrectable errors (including one from the Shared Memories) generate a Bus Fault Exception to the Cortex-M3 CPU. The less critical single errors go to the NVIC where they can result in maskable interrupts to the Cortex-M3 CPU.

### 6.3.7 Cortex-M3 Accessing Shared Resources and Analog Peripherals

There are several memories, digital peripherals, and analog peripherals that can be accessed by both the Master and Control Subsystems. They are grouped into Shared Resources and the Analog Subsystem.

The Shared Resources include the EPI, IPC registers, MTOC Message RAM, CTOM Message RAM, and eight individually configurable Shared RAM blocks. The RAMs of the Shared Resources block have Parity Error Checking.

The Message RAMs and the Shared RAMs can be accessed by the Cortex-M3 CPU and  $\mu$ DMA. The MTOC Message RAM is intended for sending data from the Master Subsystem to the Control Subsystem, having R/W access for the Cortex-M3/ $\mu$ DMA and read-only access for the C28x/DMA. The CTOM Message RAM is intended for sending data from the Control Subsystem to the Master Subsystem, having R/W access for the C28x/DMA and read-only access for the Cortex-M3/ $\mu$ DMA.

The IPC registers provide up to 32 handshaking channels to coordinate the transfer of data through the Message RAMs by polling. Four of these channels are also backed up by four interrupts to PIE on the Control Subsystem side, and four interrupts to the NVIC on the Master Subsystem side (to reduce delays associated with polling).

The eight Shared RAM blocks are similar to the Message RAMs, in that the data flow is only one way; however, the direction of the data flow can be individually set for each block to be from Master to Control Subsystem or from Control to Master Subsystem.

The Analog Subsystem has ADC1, ADC2, and Analog Comparator peripherals that can be accessed through the Analog Common Interface Bus. The ADC Result Registers are accessible by CPUs and DMAs of the Master and Control Subsystems. All other Analog Peripheral Registers are accessible by the C28x CPU only. The Cortex-M3 CPU accesses the ACIB through the System Bus, and the  $\mu$ DMA through the  $\mu$ DMA Bus. The ACIB arbitrates for access to the ADC and Analog Comparator registers between

CPU/DMA bus cycles of the Master Subsystem with those of the Control Subsystem. In addition to managing bus cycles, the ACIB also transfers End-of-Conversion ADC interrupts to the Master Subsystem (as well as to the Control Subsystem). The eight EOC sources from ADC1 and the eight EOC sources from ADC2 are AND-ed together by the ACIB, with the resulting eight ADC interrupts going to destinations in both the Master Subsystem and the Control Subsystem.

See [Section 5.10](#) for more information on shared resources and analog peripherals.

## 6.4 Control Subsystem

The Control Subsystem includes the C28x CPU/FPU/VCU, Peripheral Interrupt Expansion (PIE) block, DMA, C28x Peripherals, and Local Memory. Additionally, the C28x CPU and DMA have access to Shared Resources: IPC (CPU only), Message RAM, and Shared RAM; and to Analog Peripherals through the Analog Common Interface Bus.

[Figure 6-2](#) shows the Control Subsystem.

### 6.4.1 C28x CPU/FPU/VCU

The F28M35x Concerto MCU family is a member of the TMS320C2000 MCU platform. The Concerto C28x CPU/FPU has the same 32-bit fixed-point architecture as TI's existing Piccolo MCUs, combined with a single-precision (32-bit) IEEE 754 FPU of TI's existing Delfino MCUs. Each F28M35x device is a very efficient C/C++ engine, enabling users to develop their system control software in a high-level language. Each F28M35x device also enables math algorithms to be developed using C/C++. The device is equally efficient at DSP math tasks and at system control tasks. The 32 × 32-bit MAC 64-bit processing capabilities enable the controller to handle higher numerical resolution problems efficiently. With the addition of the fast interrupt response with automatic context save of critical registers, the device is capable of servicing many asynchronous events with minimal latency. The device has an 8-level-deep protected pipeline with pipelined memory accesses. This pipelining enables the device to execute at high speeds without resorting to expensive high-speed memories. Special branch-look-ahead hardware minimizes the latency for conditional discontinuities. Special conditional store operations further improve performance. The VCU extends the capabilities of the C28x CPU and C28x+FPU processors by adding additional instructions to accelerate Viterbi, Complex Arithmetic, 16-bit FFTs, and CRC algorithms. No changes have been made to existing instructions, pipeline, or memory bus architecture. Therefore, programs written for the C28x are completely compatible with the C28x+VCU.

There are two events generated by the FPU block that go to the C28x PIE: LVF and LUV. Inside PIE, these and other events from C28x peripherals and memories result in 12 PIE interrupts PIEINTS[12:1] into the C28x CPU. The C28x CPU also receives three additional interrupts directly (instead of through PIE) from Timer 1 (TINT1), from Timer 2 (TINT2), and from the NMI block (C28uNMIINT).

The C28x has two low-power modes: IDLE and STANDBY.

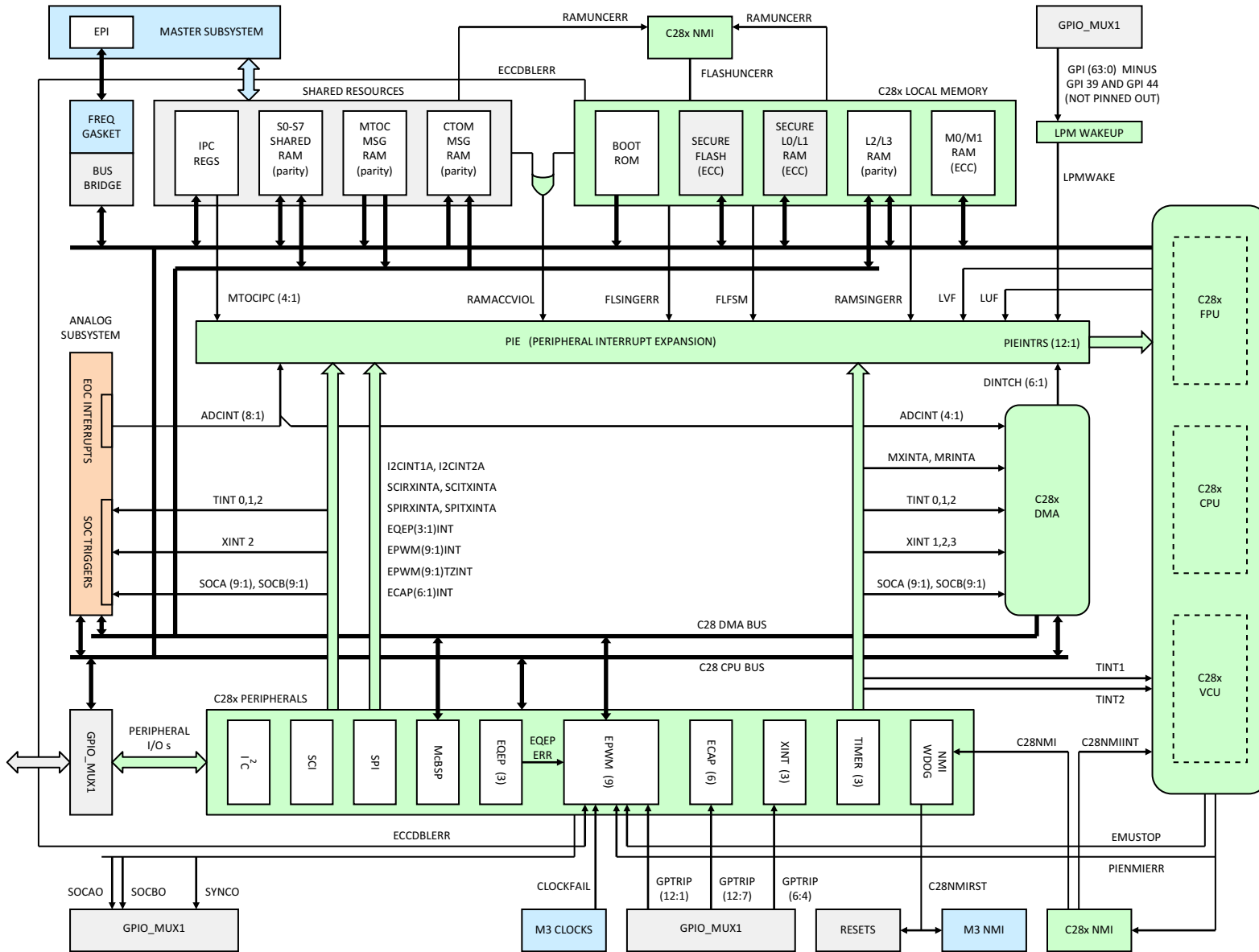

Figure 6-2. Control Subsystem

### 6.4.2 C28x Core Hardware Built-In Self-Test

The Concerto microcontroller C28x CPU core includes a HWBIST feature for testing the CPU core logic for errors. Tests using HWBIST can be initiated through a software library provided by TI.

### 6.4.3 C28x Peripheral Interrupt Expansion

The PIE block serves to multiplex numerous interrupt sources into a smaller set of interrupt inputs. The PIE block can support up to 96 peripheral interrupts. On the F28M35x, 66 of the possible 96 interrupts are used. The 96 interrupts are grouped into blocks of 8 and each group is fed into 1 of 12 CPU interrupt lines (INT1 to INT12). Each of 12 interrupt lines supports up to 8 simultaneously active interrupts. Each of the 96 interrupts has its own vector stored in a dedicated RAM block that can be overwritten by the user. The vector is automatically fetched by the CPU on servicing the interrupt. Eight CPU clock cycles are needed to fetch the vector and save critical CPU registers. Hence, the CPU can quickly respond to interrupt events. Prioritization of interrupts is controlled in hardware and software. Each individual interrupt can be enabled or disabled within the PIE block. See [Table 6-16](#) for PIE interrupt assignments.

**Table 6-16. PIE Peripheral Interrupts<sup>(1)</sup>**

| CPU INTERRUPTS | PIE INTERRUPTS              |                            |                            |                               |                               |                            |                              |                            |
|----------------|-----------------------------|----------------------------|----------------------------|-------------------------------|-------------------------------|----------------------------|------------------------------|----------------------------|
|                | INTx.8                      | INTx.7                     | INTx.6                     | INTx.5                        | INTx.4                        | INTx.3                     | INTx.2                       | INTx.1                     |
| INT1           | C28.LPMWAKE (C28LPM) 0x0D4E | TINT0 (TIMER 0) 0x0D4C     | Reserved – 0x0D4A          | XINT2 – 0x0D48                | XINT1 – 0x0D46                | Reserved – 0x0D44          | ADCINT2 (ADC) 0x0D42         | ADCINT1 (ADC) 0x0D40       |
| INT2           | EPWM8_TZINT (ePWM8) 0x0D5E  | EPWM7_TZINT (ePWM7) 0x0D5C | EPWM6_TZINT (ePWM6) 0x0D5A | EPWM5_TZINT (ePWM5) 0x0D58    | EPWM4_TZINT (ePWM4) 0x0D56    | EPWM3_TZINT (ePWM3) 0x0D54 | EPWM2_TZINT (ePWM2) 0x0D52   | EPWM1_TZINT (ePWM1) 0x0D50 |
| INT3           | EPWM8_INT (ePWM8) 0x0D6E    | EPWM7_INT (ePWM7) 0x0D6C   | EPWM6_INT (ePWM6) 0x0D6A   | EPWM5_INT (ePWM5) 0x0D68      | EPWM4_INT (ePWM4) 0x0D66      | EPWM3_INT (ePWM3) 0x0D64   | EPWM2_INT (ePWM2) 0x0D62     | EPWM1_INT (ePWM1) 0x0D60   |
| INT4           | EPWM9_TZINT (ePWM9) 0x0D7E  | Reserved – 0x0D7C          | ECAP6_INT (eCAP6) 0x0D7A   | ECAP5_INT (eCAP5) 0x0D78      | ECAP4_INT (eCAP4) 0x0D76      | ECAP3_INT (eCAP3) 0x0D74   | ECAP2_INT (eCAP2) 0x0D72     | ECAP1_INT (eCAP1) 0x0D70   |
| INT5           | EPWM9_INT (ePWM9) 0x0D8E    | Reserved – 0x0D8C          | Reserved – 0x0D8A          | Reserved – 0x0D88             | Reserved – 0x0D86             | EQEP3_INT (eQEP3) 0x0D84   | EQEP2_INT (eQEP2) 0x0D82     | EQEP1_INT (eQEP1) 0x0D80   |
| INT6           | Reserved – 0x0D9E           | Reserved – 0x0D9C          | MXINTA (McBSPA) 0x0D9A     | MRINTA (McBSPA) 0x0D98        | Reserved – 0x0D96             | Reserved – 0x0D94          | SPITXINTA (SPIA) 0x0D92      | SPIRXINTA (SPIA) 0x0D90    |
| INT7           | Reserved – 0x0DAE           | Reserved – 0x0DAC          | DINTCH6 (C28 DMA) 0x0DAA   | DINTCH5 (C28 DMA) 0x0DA8      | DINTCH4 (C28 DMA) 0x0DA6      | DINTCH3 (C28 DMA) 0x0DA4   | DINTCH2 (C28 DMA) 0x0DA2     | DINTCH1 (C28 DMA) 0x0DA0   |
| INT8           | Reserved – 0x0DBE           | Reserved – 0x0DBC          | Reserved – 0x0DBA          | Reserved – 0x0DB8             | Reserved – 0x0DB6             | Reserved – 0x0DB4          | I2CINT2A (I2CA) 0x0DB2       | I2CINT1A (I2CA) 0x0DB0     |
| INT9           | Reserved – 0x0DCE           | Reserved – 0x0DCC          | Reserved – 0x0DCA          | Reserved – 0x0DC8             | Reserved – 0x0DC6             | Reserved – 0x0DC4          | SCITXINTA (SCIA) 0x0DC2      | SCIRXINTA (SCIA) 0x0DC0    |
| INT10          | ADCINT8 (ADC) 0x0DDE        | ADCINT7 (ADC) 0x0DDC       | ADCINT6 (ADC) 0x0DDA       | ADCINT5 (ADC) 0x0DD8          | ADCINT4 (ADC) 0x0DD6          | ADCINT3 (ADC) 0x0DD4       | ADCINT2 (ADC) 0x0DD2         | ADCINT1 (ADC) 0x0DD0       |
| INT11          | Reserved – 0x0DEE           | Reserved – 0x0DEC          | Reserved – 0x0DEA          | Reserved – 0x0DE8             | MTOCIPCINT4 (IPC) 0x0DE6      | MTOCIPCINT3 (IPC) 0x0DE4   | MTOCIPCINT2 (IPC) 0x0DE2     | MTOCIPCINT1 (IPC) 0x0DE0   |
| INT12          | LUF (C28FPU) 0x0DFE         | LVF (C28FPU) 0x0DFC        | EPI_INT (EPI) 0x0DFA       | C28RAMACCVIOL (Memory) 0x0DF8 | C28RAMSINGERR (Memory) 0x0DF6 | Reserved – 0x0DF4          | C28FLSINGERR (Memory) 0x0DF2 | XINT3 (Ext. Int. 3) 0x0DF0 |

- (1) Out of the 96 possible interrupts, 66 interrupts are currently used. The remaining interrupts are reserved for future devices. These interrupts can be used as software interrupts if they are enabled at the PIEIFRx level, provided none of the interrupts within the group is being used by a peripheral. Otherwise, interrupts coming in from peripherals may be lost by accidentally clearing their flag while modifying the PIEIFR. To summarize, there are two safe cases when the reserved interrupts could be used as software interrupts:
- 1) No peripheral within the group is asserting interrupts.
  - 2) No peripheral interrupts are assigned to the group (example PIE group 11).

#### 6.4.4 C28x Direct Memory Access

The C28x DMA module provides a hardware method of transferring data between peripherals, between memory, and between peripherals and memory without intervention from the CPU, thereby freeing up bandwidth for other system functions. Additionally, the DMA has the capability to orthogonally rearrange the data as the data is transferred as well as “ping-pong” data between buffers. These features are useful for structuring data into blocks for optimal CPU processing. The interrupt trigger source for each of the six DMA channels can be configured separately and each channel contains its own independent PIE interrupt to notify the CPU when a DMA transfer has either started or completed. Five of the six channels are exactly the same, while Channel 1 has one additional feature: the ability to be configured at a higher priority than the others.

#### 6.4.5 C28x Local Peripherals

The C28x local peripherals include an NMI Watchdog, three Timers, four Serial Port Peripherals (SCI, SPI, McBSP, I2C), an EPI, and three types of Control Peripherals (ePWM, eQEP, eCAP). All peripherals are accessible by the C28x CPU through the C28x Memory Bus. Additionally, the McBSP and ePWM are accessible by the C28x DMA Bus. The EPI peripheral is also accessible from the Master Subsystem. The Serial Port Peripherals and the Control Peripherals connect to the pins in Concerto through the GPIO\_MUX1 block. Internally, the C28x peripherals generate events to the PIE block, C28x DMA, and the Analog Subsystem. The C28x NMI Watchdog receives a C28NMI event from the NMI block and sends a counter time-out event to the Cortex-M3 NMI block and the Resets block to flag a potentially critical condition.

The ePWM peripheral receives events that can be used to trip the ePWM outputs EPWMxA and EPWMxB. These events include ECCDBLERR event from the C28x Local Memory, PIENMIERR and EMUSTOP events from the C28x CPU, and up to 12 trips from GPIO\_MUX1.

See [Section 5.12](#) for more information on C28x peripherals.

#### 6.4.6 C28x Local Memory

The C28x Local Memory includes Boot ROM; Secure Flash with ECC; Secure L0/L1 RAM with ECC; L2/L3 RAM with Parity Error Checking; and M0/M1 with ECC. All local memories are accessible from the C28x CPU; the L2/L3 RAM is also accessible by the C28x DMA. Two types of error correction events can be generated during access of the C28x Local Memory: uncorrectable errors and single errors. The uncorrectable errors propagate to the NMI block where they can become the C28NMI to the C28x NMI Watchdog and the C28NMIINT nonmaskable interrupt to the C28x CPU. The less critical single errors go to the PIE block where they can become maskable interrupts to the C28x CPU.

#### 6.4.7 C28x Accessing Shared Resources and Analog Peripherals

There are several memories, digital peripherals, and analog peripherals that can be accessed by both the Master and Control Subsystems. They are grouped into the Shared Resources and the Analog Subsystem.

The Shared Resources include the EPI, IPC registers, MTOC Message RAM, CTOM Message RAM, and eight individually configurable Shared RAM blocks.

The Message RAMs and the Shared RAMs can be accessed by the C28x CPU and DMA and have Parity-Error Checking. The MTOC Message RAM is intended for sending data from the Master Subsystem to the Control Subsystem, having R/W access for the Cortex-M3/μDMA and read-only access for the C28x/DMA. The CTOM Message RAM is intended for sending data from the Control Subsystem to the Master Subsystem, having R/W access for the C28x/DMA and read-only access for the Cortex-M3/μDMA.

The IPC registers provide up to 32 handshaking channels to coordinate transfer of data through the Message RAMs by polling. Four of these channels are also backed up by four interrupts to PIE on the Control Subsystem side, and four interrupts to the NVIC on the Master Subsystem side (to reduce delays associated with polling).

The eight Shared RAM blocks are similar to the Message RAMs, in that the data flow is only one way; however, the direction of the data flow can be individually set for each block to be from Master to Control Subsystem or from Control to Master Subsystem.

See [Section 5.10](#) for more information on shared resources and analog peripherals.

## 6.5 Analog Subsystem

The Analog Subsystem has ADC1, ADC2, and six Analog Comparator + DAC units that can be accessed through the Analog Common Interface Bus. The ADC Result Registers are accessible by CPUs and DMAs of the Master and Control Subsystems. All other Analog Peripheral Registers are accessible by the C28x CPU only. The C28x CPU accesses the ACIB through the C28x Memory Bus, and the C28x DMA through the C28x DMA Bus. The ACIB arbitrates for access to ADC and Analog Comparator registers between CPU/DMA bus cycles of the C28x Subsystem with those of the Cortex-M3 Subsystem. In addition to managing bus cycles, the ACIB also transfers Start-Of-Conversion triggers to the Analog Subsystem and returns End-Of-Conversion ADC interrupts to both the Master Subsystem and the Control Subsystem.

There are 22 possible Start-Of-Conversion (SOC) sources from the C28x Subsystem that are mapped to a total of 8 possible SOC triggers inside the Analog Subsystem (to ADC1 and ADC2).

Going the other way, eight End-Of-Conversion (EOC) sources from ADC1 and eight EOC sources from ADC2 are AND-ed together to form eight interrupts going to destinations in both the Master and Control Subsystems. Inside the C28x Subsystem, all eight EOC interrupts go to the PIE, but only four of the same eight go to the C28x DMA.

The Concerto MCU Analog Subsystem has two independent Analog-to-Digital Converters (ADC1, ADC2); six Analog Comparators + DAC units; and an ACIB to facilitate analog data communications with the two digital subsystems of Concerto (Cortex-M3 and C28x).

[Figure 6-3](#) shows the Analog Subsystem.

### 6.5.1 ADC1

The ADC1 consists of a 12-bit Analog-to-Digital converter with up to 16 analog input channels of which 10 are currently pinned out. The analog channels are internally preassigned to two Sample-and-Hold (S/H) units A and B, both feeding an Analog Mux whose output is converted to a 12-bit digital value and stored in ADC1 result registers. The two S/H units enable simultaneous sampling of two analog signals at a time. Additional channels or channel pairs are converted sequentially. SOC triggers from the Control Subsystem initiate analog-to-digital conversions. EOC interrupts from ADCs notify the Master and Control Subsystems that the conversion results are ready to be read from ADC1 result registers. See [Section 5.10.1](#) for more information on ADC peripherals.

### 6.5.2 ADC2

The ADC2 consists of a 12-bit Analog-to-Digital converter with up to 16 analog input channels of which 10 are currently pinned out. The analog channels are internally preassigned to two S/H units A and B, both feeding an Analog Mux whose output is converted to a 12-bit digital value and stored in the ADC2 result registers. The two S/H units enable simultaneous sampling of two analog signals at a time. Additional channels or channel pairs are converted sequentially. SOC triggers from the Control Subsystem initiate analog-to-digital conversions. EOC interrupts from ADCs notify the Master and Control Subsystems that the conversion results are ready to be read from ADC2 result registers. See [Section 5.10.1](#) for more information on ADC peripherals.

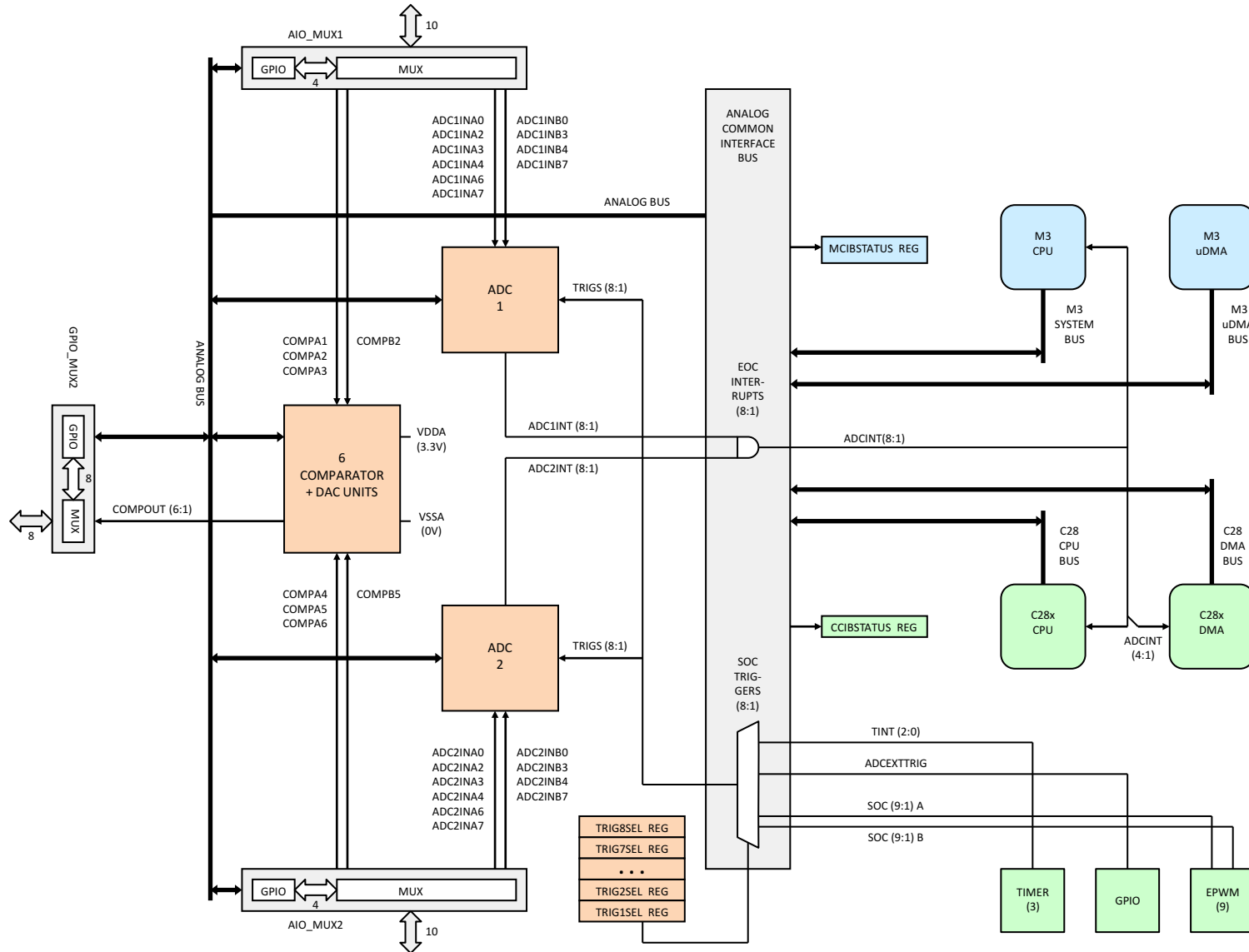

Figure 6-3. Analog Subsystem

### 6.5.3 Analog Comparator + DAC

There are six Comparator blocks enabling simultaneous comparison of multiple pairs of analog inputs, resulting in six digital comparison outputs. The external analog inputs that are being compared in the comparators come from AIO\_MUX1 and AIO\_MUX2 blocks. These analog inputs can be compared against each other or the outputs of 10-bit DACs (Digital-to-Analog Converters) inside individual Comparator modules. The six comparator outputs go to the GPIO\_MUX2 block where they can be mapped to six out of eight available pins.

To use these comparator outputs to trip the C28x EPWMA/B outputs, they must be first routed externally from pins of the GPIO\_MUX2 block to selected pins of the GPIO\_MUX1 block before they can be assigned to selected 12 ePWM Trip Inputs.

See [Section 5.10.2](#) for more information on the analog comparator + DAC.

### 6.5.4 Analog Common Interface Bus

The ACIB links the Master and Control Subsystems with the Analog Subsystem. The ACIB enables the Cortex-M3 CPU/ $\mu$ DMA and C28x CPU/DMA to access Analog Subsystem registers, to send SOC Triggers to the Analog Subsystem, and to receive EOC Interrupts from the Analog Subsystem. The Cortex-M3 uses its System Bus and the  $\mu$ DMA Bus to read from ADC Result registers. The C28x uses its Memory Bus and the DMA bus to access ADC Result registers and other registers of the Analog Subsystem. The ACIB arbitrates between up to four possibly simultaneously occurring bus cycles on the Master/Control Subsystem side of ACIB to access the ADC and Analog Comparator registers on the Analog Subsystem side.

Additionally, ACIB maps up to 22 SOC trigger sources from the Control Subsystem to 8 SOC trigger destinations inside the Analog Subsystem (shared between ADC1 and ADC2), and up to 16 ADC EOC interrupt sources from the Analog Subsystem to 8 destinations inside the Master and Control Subsystems. The eight ADC interrupts are the result of AND-ing of eight EOC interrupts from ADC1 with 8 EOC interrupts from ADC2. The total of 16 possible ADC1 and ADC2 interrupts are sharing the 8 interrupt lines because it is unlikely that any application would need all 16 interrupts at the same time.

Eight registers (TRIG1SEL–TRIG8SEL) configure eight corresponding SOC triggers to assign 1 of 22 possible trigger sources to each SOC trigger.

There are two registers that provide status of ACIB to the Master Subsystem and to the Control Subsystem.

The Cortex-M3 can read the MCIBSTATUS register to verify that the Analog Subsystem is properly powered up; the Analog System Clock (ASYSCLK) is present; and that the bus cycles, triggers, and interrupts are correctly propagating between the Master, Control, and Analog subsystems.

The C28x can read the CCIBSTATUS register to verify that the Analog Subsystem is properly powered up; the Analog System Clock (ASYSCLK) is present; and that the bus cycles, triggers, and interrupts are correctly propagating between the Master, Control, and Analog subsystems.

## 6.6 Master Subsystem NMIs

The Cortex-M3 NMI Block generates an M3NMIINT nonmaskable interrupt to the Cortex-M3 CPU and an M3NMI event to the NMI Watchdog in response to potentially critical conditions existing inside or outside the Concerto MCU. When able to respond to the M3NMIINT interrupt, the Cortex-M3 CPU may address the NMI condition and disable the NMI Watchdog. Otherwise, the NMI Watchdog counts out and an M3NMIRST reset signal is sent to the Resets block.

The inputs to the Cortex-M3 NMI block include the C28NMIRST, PIENMIERR, CLOCKFAIL, ACIBERR, EXTGPIO, MLBISTERR, and CLBISTERR signals. The C28NMIRST comes from the C28x NMI Watchdog; C28NMIRST indicates that the C28x was not able to prevent the C28x NMI Watchdog counter from counting out. PIENMIERR indicates that an error condition was generated during the NMI vector fetch from the C28x PIE block. The CLOCKFAIL input comes from the Master Clocks Block, announcing a missing clock source to the Main Oscillator. ACIBERR indicates an abnormal condition inside the Analog Common Interface Bus. EXTGPIO comes from the GPIO\_MUX1 to announce an external emergency. MLBISTERR is generated by the Cortex-M3 core to signal that a BIST time-out or signature mismatch error has been detected. CLBISTERR is generated by the C28x core to signal that a BIST time-out or signature mismatch error has been detected.

The Cortex-M3 NMI block can be accessed through the Cortex-M3 NMI configuration registers—including the MNMIFLG, MNMIFLGCLR, and MNMIFLGFRC registers—to examine flag bits for the NMI sources, clear the flags, and force the flags to active state, respectively.

[Figure 6-4](#) shows the Cortex-M3 NMI and C28x NMI.

## 6.7 Control Subsystem NMIs

The C28x NMI Block generates a C28NMIINT nonmaskable interrupt to the C28x CPU and a C28NMI event to the C28x NMI Watchdog in response to potentially critical conditions existing inside the Concerto MCU. When able to respond to the C28NMIINT interrupt, the C28x CPU may address the NMI condition and disable the C28x NMI Watchdog. Otherwise, the C28x NMI Watchdog counts out and the C28NMIRST reset signal is sent to the Resets block and the Cortex-M3 NMI Block, where the Cortex-M3 NMI Block can generate an NMI to the Cortex-M3 processor.

The inputs to the C28x NMI block include the CLOCKFAIL, ACIBERR, RAMUNCERR, FLASHUNCERR, PIENMIERR, CLBISTERR, and MLBISTERR signals. The CLOCKFAIL input comes from the Clocks Block, announcing a missing clock source to the Main Oscillator. ACIBERR indicates an abnormal condition inside the Analog Common Interface Bus. The RAMUNCERR and FLASHUNCERR announce the occurrence of uncorrectable error conditions during access to the Flash or RAM (local or shared). PIENMIERR indicates that an error condition was generated during NMI vector fetch from the C28x PIE block. MLBISTERR is generated by the Cortex-M3 core to signal that a BIST time-out or signature mismatch error has been detected. CLBISTERR is generated by the C28x core to signal that a BIST time-out or signature mismatch error has been detected.

The C28x NMI block can be accessed through the C28x NMI configuration registers—including the CNMIFLG, CNMIFLGCLR, and CNMIFLGFRC registers—to examine flag bits for the NMI sources, clear the flags, and force the flags to active state, respectively.

[Figure 6-4](#) shows the Cortex-M3 NMI and C28x NMI.

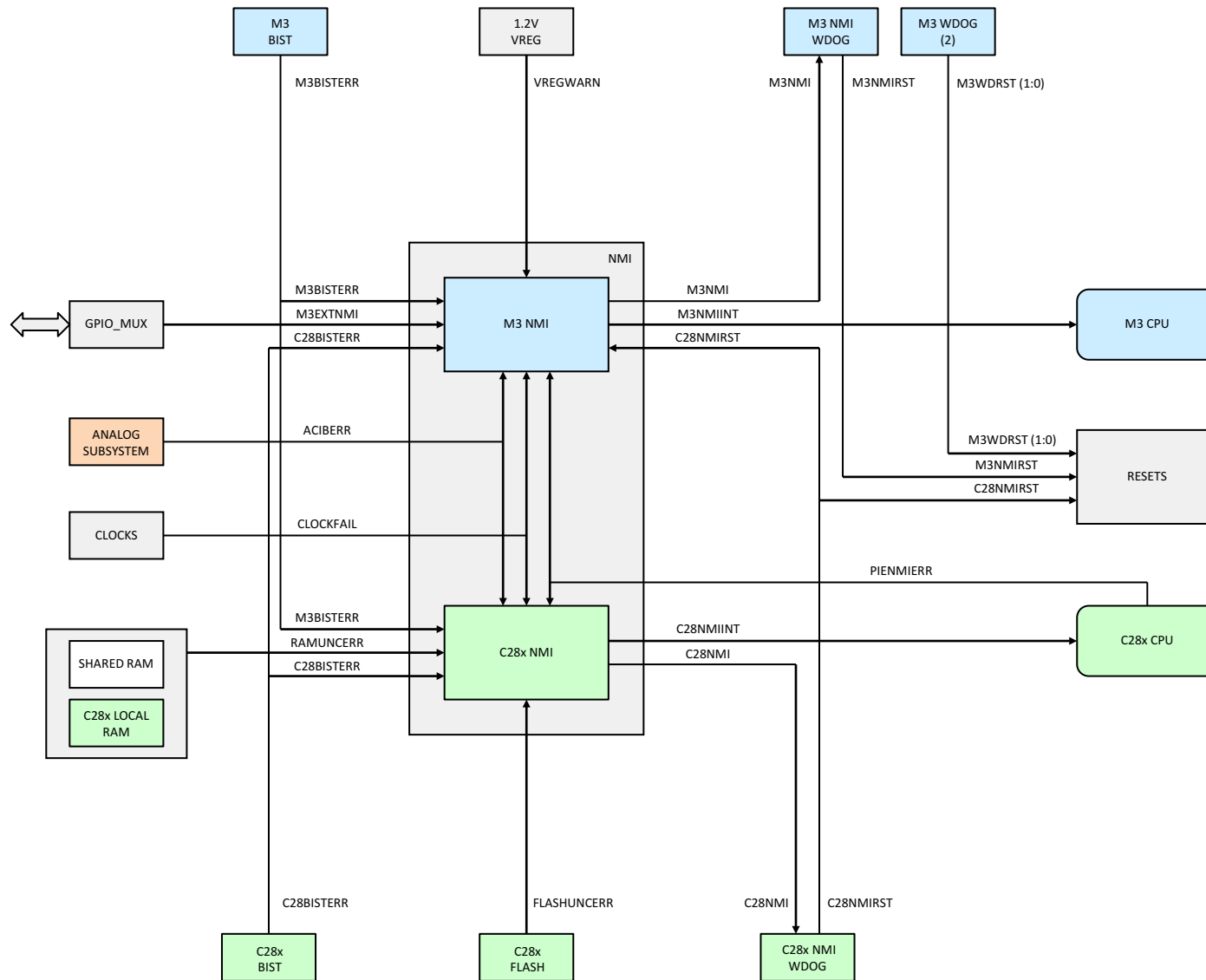

**Figure 6-4. Cortex-M3 NMI and C28x NMI**

## 6.8 Resets

The Concerto MCU has two external reset pins:  $\overline{XRS}$  for the Master and Control Subsystems and  $\overline{ARS}$  for the Analog Subsystem. TI recommends that these two pins be externally tied together with a board signal trace.

The  $\overline{XRS}$  pin can receive an external reset signal from outside into the chip, and the pin can drive a reset signal out from inside of the chip. A reset pulse driven into the  $\overline{XRS}$  pin resets the Master and Control Subsystems. A reset pulse can also be driven out of the  $\overline{XRS}$  pin by the Power-On Reset (POR) block of the Master and Control Subsystems (see [Section 6.9](#)). A reset pulse can be driven out of the  $\overline{XRS}$  pin when the two Cortex-M3 Watchdogs or the Cortex-M3 NMI Watchdog time-out.

There are some requirements on the  $\overline{XRS}$  pin:

1. During power up, the  $\overline{XRS}$  pin must be held low for at least eight X1 cycles after the input clock is stable. This requirement is to enable the entire device to start from a known condition.
2. TI recommends that no voltage larger than 0.7 V be applied to any pin before powering up the device. Voltages applied to pins on an unpowered device can lead to unpredictable results.

The  $\overline{ARS}$  pin can receive an external reset signal from outside into the chip, and the pin can drive a reset signal out from inside of the chip. A reset pulse driven into the  $\overline{ARS}$  pin resets the Analog Subsystem. A reset pulse can be driven out of the  $\overline{ARS}$  pin by the POR block of the Analog Subsystem.

[Figure 6-5](#) shows the resets.

### 6.8.1 Cortex-M3 Resets

The Cortex-M3 CPU and NVIC (Nested Vectored Interrupt Controller) are both reset by the POR or the M3SYSRST reset signal. In both cases, the Cortex-M3 CPU restarts program execution from the address provided by the reset entry in the vector table. A register can later be referenced to determine the source of the reset. The M3SYSRST signal also propagates to the Cortex-M3 peripherals and the rest of the Cortex-M3 Subsystem.

The  $\overline{M3SYSRST}$  has four possible sources:  $\overline{XRS}$ ,  $\overline{M3WDOGS}$ ,  $\overline{M3SWRST}$ , and  $\overline{M3DBGRST}$ . The  $\overline{M3WDOGS}$  is set in response to time-out conditions of the two Cortex-M3 Watchdogs or the Cortex-M3 NMI Watchdog. The  $\overline{M3SWRST}$  is a software-generated reset output by the NVIC. The  $\overline{M3DBGRST}$  is a debugger-generated reset that is also output by the NVIC. In addition to driving M3SYSRST, these two resets also propagate to the C28x Subsystem and the Analog Subsystem.

The M3RSNIN bit can be set inside the CRESCNF register to selectively reset the C28x Subsystem from the Cortex-M3, and ACIBRST bit of the same register selectively resets the Analog Common Interface Bus. In addition to driving reset signals to other parts of the chip, the Cortex-M3 can also detect a  $\overline{C28SYSRST}$  reset being set inside the C28x Subsystem by reading the CRES bit of the CRESSTS register.

Cortex-M3 software can also set bits in the SRCR register to selectively reset individual Cortex-M3 peripherals, provided they are enabled inside the DC (Device Configuration) register. The Reset Cause register (MRESC) can be read to find out if the latest reset was caused by External Reset, POR, Watchdog Timer 0, Watchdog Timer 1, or Software Reset from NVIC.

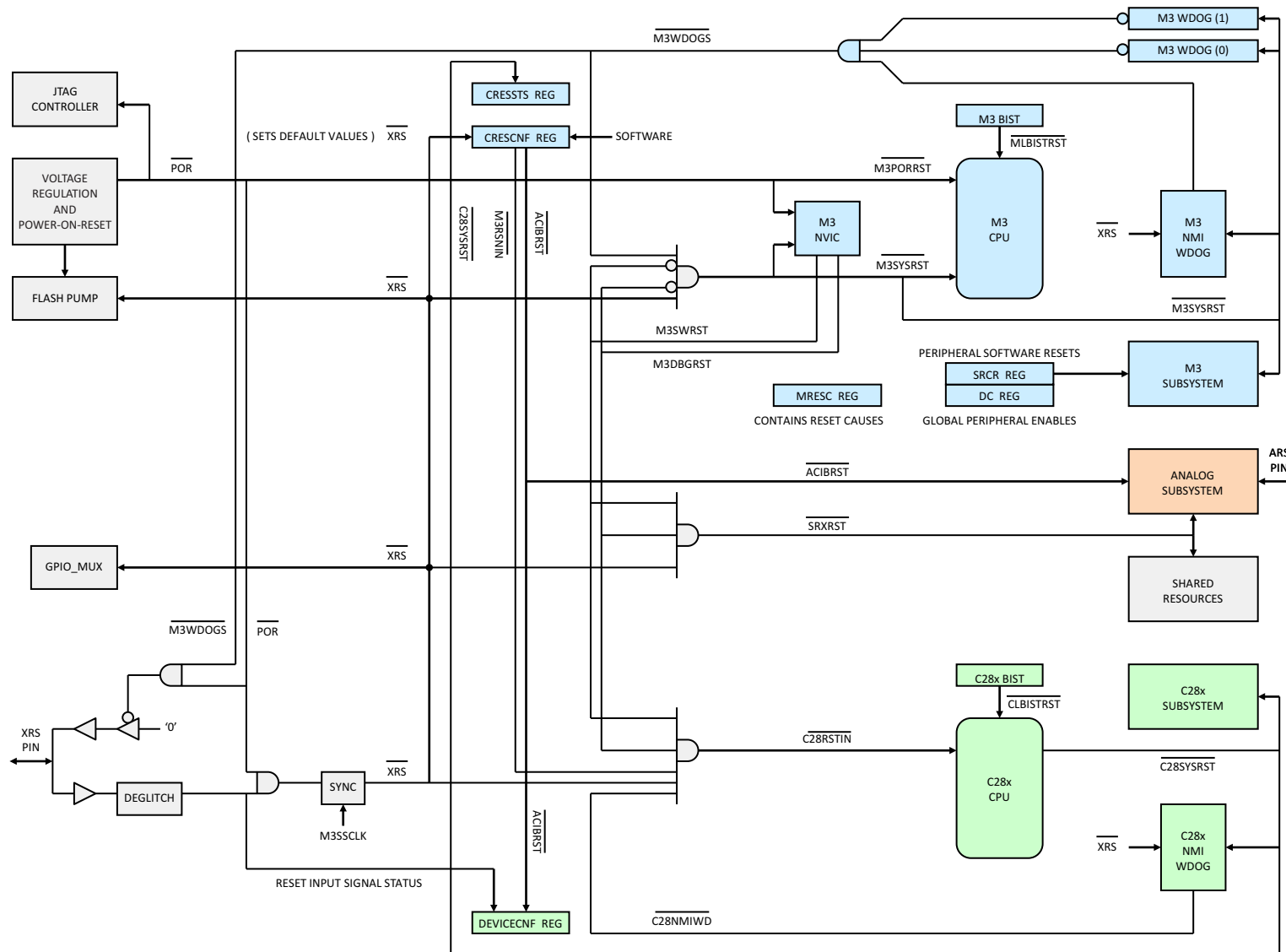

Figure 6-5. Resets

## 6.8.2 C28x Resets

The C28x CPU is reset by the  $\overline{\text{C28RSTIN}}$  signal, and the C28x CPU in turn resets the rest of the C28x Subsystem with the  $\overline{\text{C28SYSRST}}$  signal. When reset, the C28x restarts program execution from the address provided at the top of the Boot ROM Vector Table.

The  $\overline{\text{C28RSTIN}}$  has five possible sources:  $\overline{\text{XRS}}$ ,  $\overline{\text{C28NMIWD}}$ ,  $\overline{\text{M3SWRST}}$ ,  $\overline{\text{M3DBGSRST}}$ , and the  $\overline{\text{M3RSNIN}}$ . The  $\overline{\text{C28NMIWD}}$  is set in response to time-out conditions of the C28x NMI Watchdog. The  $\overline{\text{M3SWRST}}$  is a software-generated reset output by the NVIC. The  $\overline{\text{M3DBGSRST}}$  is a debugger-generated reset that is also output by the NVIC. These two resets must be first enabled by the Cortex-M3 processor in order to propagate to the C28x Subsystem.  $\overline{\text{M3RSNIN}}$  reset comes from the Cortex-M3 Subsystem to selectively reset the C28x Subsystem from Cortex-M3 software.

The C28x processor can learn the status of the internal  $\overline{\text{ACIBRST}}$  reset signal and the external  $\overline{\text{XRS}}$  pin by reading the DEVICECNF register.

## 6.8.3 Analog Subsystem and Shared Resources Resets

Both the Analog Subsystem and the resources shared between the C28x and Cortex-M3 subsystems (IPC, MSG RAM, Shared RAM) are reset by the SRXRST reset signal. Additionally, the Analog Subsystem is also reset by the internal ACIBRST signal from the Cortex-M3 Subsystem and the external  $\overline{\text{ARS}}$  pin, (should be externally tied to the  $\overline{\text{XRS}}$  pin), which can be reset by the POR circuitry.

The SRXRST has three possible sources:  $\overline{\text{XRS}}$ ,  $\overline{\text{M3SWRST}}$ , and  $\overline{\text{M3DBGSRST}}$ . The  $\overline{\text{M3SWRST}}$  is a software-generated reset output by the NVIC. The  $\overline{\text{M3DBGSRST}}$  is a debugger-generated reset that is also output by the NVIC. These two resets must be first enabled by the Cortex-M3 processor in order to propagate to the Analog Subsystem and the Shared Resources.

Although EPI is a shared peripheral, it is physically located inside the Cortex-M3 Subsystem; therefore, EPI is reset by  $\overline{\text{M3SYSRST}}$ .

## 6.8.4 Device Boot Sequence

The boot sequence of Concerto is used to configure the Master Subsystem and the Control Subsystem for execution of application code. The boot sequence involves both internal resources, and resources external to the device. These resources include: Master Subsystem Bootloader code (M-Bootloader) factory-programmed inside the Master Subsystem Boot ROM (M-Boot ROM); Control Subsystem Bootloader code (C-Bootloader) factory-programmed inside the Control Subsystem Boot ROM (C-Boot ROM); four GPIO\_MUX pins for Master boot mode selection; internal Flash and RAM memories; and selected Cortex-M3 and C28x peripherals for loading the application code into the Master and Control Subsystems.

The boot sequence starts when the Master Subsystem comes out of reset, which can be caused by device power up, external reset, debugger reset, software reset, Cortex-M3 watchdog reset, or Cortex-M3 NMI watchdog reset. While the M-Bootloader starts executing first, the C-Bootloader starts soon after, and then both bootloaders work in tandem to configure the device, load application code for both processors (if not already in the Flash), and branch the execution of each processor to a selected location in the application code.

Execution of the M-Bootloader commences when an internal reset signal goes from active to inactive state. At that time, the Control Subsystem and the Analog Subsystem continue to be in reset state until the Master Subsystem takes them out of reset. The M-Bootloader first initializes some device-level functions, then the M-Bootloader initializes the Master Subsystem. Next, the M-Bootloader takes the Control Subsystem and the Analog Subsystem/ACIB out of reset. When the Control Subsystem comes out of reset, its own C-Bootloader starts executing in parallel with the M-Bootloader. After initializing the Control Subsystem, the C-Bootloader enters the C28x processor into the IDLE mode (to wait for the M-Bootloader to wake up the C28x processor later through the MTOCIPC1 interrupt). Next, the M-Bootloader reads four GPIO pins (see [Table 6-17](#)) to determine the boot mode for the rest of the M-Bootloader operation.

**Table 6-17. Master Subsystem Boot Mode Selection<sup>(1)</sup>**

| BOOT MODE NO.     | MASTER SUBSYSTEM BOOT MODES                                     | PF2_GPIO34 (Bmode_pin4) <sup>(2) (3)</sup> | PF3_GPIO35 (Bmode_pin3) <sup>(2)</sup> | PG7_GPIO47 (Bmode_pin2) <sup>(2)</sup> | PG3_GPIO43 (Bmode_pin1) <sup>(2)</sup> |
|-------------------|---|--|--|--|--|
| 0                 | Boot from Parallel GPIO   | 0  | 0                                      | 0                                      | 0                                      |
| 1                 | Boot to Master Subsystem RAM                                    | 0  | 0                                      | 0                                      | 1                                      |
| 2                 | Boot from Master Subsystem serial peripherals (UART0/SSI0/I2C0) | 0  | 0                                      | 1                                      | 0                                      |
| 3                 | Boot from Master Subsystem CAN interface                        | 0  | 0                                      | 1                                      | 1                                      |
| 4                 | Boot from Master Subsystem Ethernet interface                   | 0  | 1                                      | 0                                      | 0                                      |
| 5                 | Not supported (Defaults to Boot-to-Flash)                       | 0  | 1                                      | 0                                      | 1                                      |
| 6 <sup>(5)</sup>  | Boot-to-OTP   | 0  | 1                                      | 1                                      | 0                                      |
| 7                 | Boot to Master Subsystem Flash memory                           | 0  | 1                                      | 1                                      | 1                                      |
| 8 <sup>(4)</sup>  | Not supported (Defaults to Boot-to-Flash)                       | 1  | 0                                      | 0                                      | 0                                      |
| 9 <sup>(4)</sup>  | Boot from Master Subsystem serial peripheral – SSI0 Master      | 1  | 0                                      | 0                                      | 1                                      |
| 10 <sup>(4)</sup> | Boot from Master Subsystem serial peripheral – I2C0 Master      | 1  | 0                                      | 1                                      | 0                                      |
| 11 <sup>(4)</sup> | Not supported (Defaults to Boot-to-Flash)                       | 1  | 0                                      | 1                                      | 1                                      |
| 12 <sup>(4)</sup> | Not supported (Defaults to Boot-to-Flash)                       | 1  | 1                                      | 0                                      | 0                                      |
| 13 <sup>(4)</sup> | Not supported (Defaults to Boot-to-Flash)                       | 1  | 1                                      | 0                                      | 1                                      |
| 14 <sup>(4)</sup> | Not supported (Defaults to Boot-to-Flash)                       | 1  | 1                                      | 1                                      | 0                                      |
| 15 <sup>(4)</sup> | Not supported (Defaults to Boot-to-Flash)                       | 1  | 1                                      | 1                                      | 1                                      |

(1) Silicon revision A allows the user to change the GPIO pins used to determine the boot mode. Silicon revision 0 does not have this option. See the [Concerto F28M35x Technical Reference Manual](#) for additional information.

(2) By default, GPIO terminals are not pulled up (they are floating).

(3) On silicon revision 0, PF2\_GPIO34 is a "don't care". So, the state of PF2\_GPIO34 should not affect boot mode selection.

(4) Boot Modes 8–15 are not supported on silicon revision 0.

(5) Supported only in TMS version. On all other versions, this mode defaults to Boot-to-Flash.

Boot Mode 7 and Boot Mode 15 cause the Master program to branch execution to the application in the Master Flash memory. This branching requires that the Master Flash be already programmed with valid code; otherwise, a hard fault exception is generated and the Cortex-M3 goes back to the above reset sequence. (Therefore, for a factory-fresh device, the M-Bootloader will be in a continuous reset loop until the emulator is connected and a debug session started.) If the Master Subsystem Flash has already been programmed, the application code will start execution. Typically, the Master Subsystem application code will then establish data communication with the C28x [through the IPC (Interprocessor Communications peripheral)] to coordinate the rest of the boot process with the Control Subsystem. Following reset, the internal pullup resistors on GPIOs are disabled. Therefore, Boot Mode 15, for example, will typically require four external pullups.

Boot Mode 1 causes the Master boot program to branch to Cortex-M3 RAM, where the Cortex-M3 processor starts executing code that has been preloaded earlier. Typically, this mode is used during development of application code meant for Flash, but which has to be first tested running out of RAM. In this case, the user would typically load the application code into RAM using the debugger, and then issue a debugger reset, while setting the four boot pins to 0001b. From that point on, the rest of the boot process on the Master Subsystem side is controlled by the application code.

Boot Modes 0, 2, 3, 4, 9, 10, and 12 are used to load the Master application code from an external peripheral before branching to the application code. This process is different from the process in Boot Modes 1, 7, and 15, where the application code was either already programmed in Flash or loaded into RAM by the emulator. If the boot mode selection pins are set to 0000b, the M-Bootloader (running out of M-Boot ROM) will start uploading the Master application code from preselected Parallel GPIO\_MUX pins. If the boot pins are set to 0010b, the application code will be loaded from the Master Subsystem UART0, SSI0, or I2C0 peripheral. (SSI0 and I2C0 are configured to work in Slave mode in this Boot Mode.) If the

boot pins are set to 0011b, the application code will be loaded from the Master Subsystem CAN interface. Furthermore, if the boot pins are set to 0100b, the application code will be loaded through the Master Subsystem Ethernet interface; the IOs used in this Boot Mode are compatible with the F28M35x device. If the boot pins are set to 1001b or 1010b, then the application code will be loaded through the SSI0 or I2C0 interface, respectively. SSI0 and I2C0 loaders work in Master Mode in this boot mode.

Regardless of the type of boot mode selected, once the Master application code is resident in Master Flash or RAM, the next step for the M-Bootloader is to branch to Master Flash or RAM. At that point, the application code takes over control from the M-Bootloader, and the boot process continues as prescribed by the application code. At this stage, the Master application program typically establishes communication with the C-Bootloader, which by now, would have already initialized the Control Subsystem and forced the C28x to go into IDLE mode. To wake the Control Subsystem out of IDLE mode, the Master application issues the Master-to-Control-IPC-interrupt 1 (MTOCIPCINT1). Once the data communication has been established through the IPC, the boot process can now also continue on the Control Subsystem side.

The rest of the Control Subsystem boot process is controlled by the Master Subsystem application issuing IPC instructions to the Control Subsystem, with the C-Bootloader interpreting the IPC commands and acting on them to continue the boot process. At this stage, a boot mode for the Control Subsystem can be established. The Control Subsystem boot modes are similar to the Master Subsystem boot modes, except for the mechanism by which they are selected. The Control Subsystem boot modes are chosen through the IPC commands from the Master application code to the C-Bootloader, which interprets them and acts accordingly. The choices are, as above, to branch to already existing Control application code in Flash, to branch to preloaded code in RAM (development mode), or to upload the Control application code from one of several available peripherals (see [Table 6-18](#)). As before, once the Control application code is in place (in Flash or RAM), the C-Bootloader branches to Flash or RAM, and from that point on, the application code takes over.

**Table 6-18. Control Subsystem Boot Mode Selection**

| CONTROL SUBSYSTEM BOOT MODES | MTOCIPCBOOTMODE REGISTER VALUE | DESCRIPTION  |
|------------------------------|--------------------------------|--|
| BOOT_FROM_RAM                | 0x0000 0001                    | Upon receiving this command from the Master Subsystem, C-Boot ROM will branch to the Control Subsystem RAM entry point location and start executing code from there. |
| BOOT_FROM_FLASH              | 0x0000 0002                    | Upon receiving this command, C-Boot ROM will branch to the Control Subsystem FLASH entry point and start executing code from there.                                  |
| BOOT_FROM_SCI                | 0x0000 0003                    | Upon receiving this command, C-Boot ROM will boot from the Control Subsystem SCI peripheral.   |
| BOOT_FROM_SPI                | 0x0000 0004                    | Upon receiving this command, C-Boot ROM will boot from the Control Subsystem SPI interface.  |
| BOOT_FROM_I2C                | 0x0000 0005                    | Upon receiving this command, C-Boot ROM will boot from the Control Subsystem I2C interface.  |
| BOOT_FROM_PARALLEL           | 0x0000 0006                    | Upon receiving this command, C-Boot ROM will boot from the Control Subsystem GPIO.   |

The boot process can be considered completed once the Cortex-M3 and C28x are both running out of their respective application programs. Following the boot sequence, the C-Bootloader is still available to interpret and act upon an assortment of IPC commands that can be issued from the Master Subsystem to perform a variety of configuration, housekeeping, and other functions. See the [Concerto F28M35x Technical Reference Manual](#) for additional information on Concerto boot modes, IPC commands, and the underlying boot philosophy.

## 6.9 Internal Voltage Regulation and Power-On-Reset Functionality

While the analog functions of Concerto draw power from a single dedicated external power source— $V_{DDA}$ , its digital circuits are powered by three separate rails: 3.3-V  $V_{DDIO}$ , 1.8-V  $V_{DD18}$ , and 1.2-V  $V_{DD12}$ . This section describes the sourcing, regulation, and POR functionality for these three digital power rails.

Concerto devices can be internally divided into an Analog Subsystem and a Digital Subsystem (having the Cortex-M3-based Master Subsystem and the C28x-based Control Subsystem). The Digital Subsystem uses  $V_{DD12}$  to power the two processors, internal memory, and peripherals. The Analog Subsystem uses  $V_{DD18}$  to power the digital logic associated with the analog functions. Both Digital and Analog Subsystems share a common  $V_{DDIO}$  rail to power their 3.3-V I/O buffers through which the Concerto digital signals communicate with the outside world.

The Analog and Digital Subsystems each have their own POR circuits that operate independently. With the  $\overline{ARS}$  and  $\overline{XRS}$  reset pins externally tied together, both systems can come out of reset together, and can also be put in reset together by driving both reset pins low. See [Figure 6-6](#) for a snapshot of the voltage regulation and POR functions provided within the Analog and Digital Subsystems of Concerto.

### 6.9.1 Analog Subsystem: Internal 1.8-V VREG

The internal 1.8-V Voltage Regulator (VREG) generates  $V_{DD18}$  power from  $V_{DDIO}$ . The 1.8-V VREG is enabled by pulling the  $\overline{VREG18EN}$  pin to a low state. When enabled, the 1.8V VREG provides 1.8 V to digital logic associated with the analog functions of the Analog Subsystem.

When the internal 1.8-V VREG function is enabled, the 1.8 V power no longer has to be provided externally; however, a 1.2- $\mu$ F (10% tolerance) capacitor is required for each  $V_{DD18}$  pin to stabilize the internally generated voltages. These load capacitors are not required if the internal 1.8-V VREG is disabled, and the 1.8 V is provided from an external supply.

While removing the need for an external power supply, enabling the internal VREG might affect the  $V_{DDIO}$  power consumption.

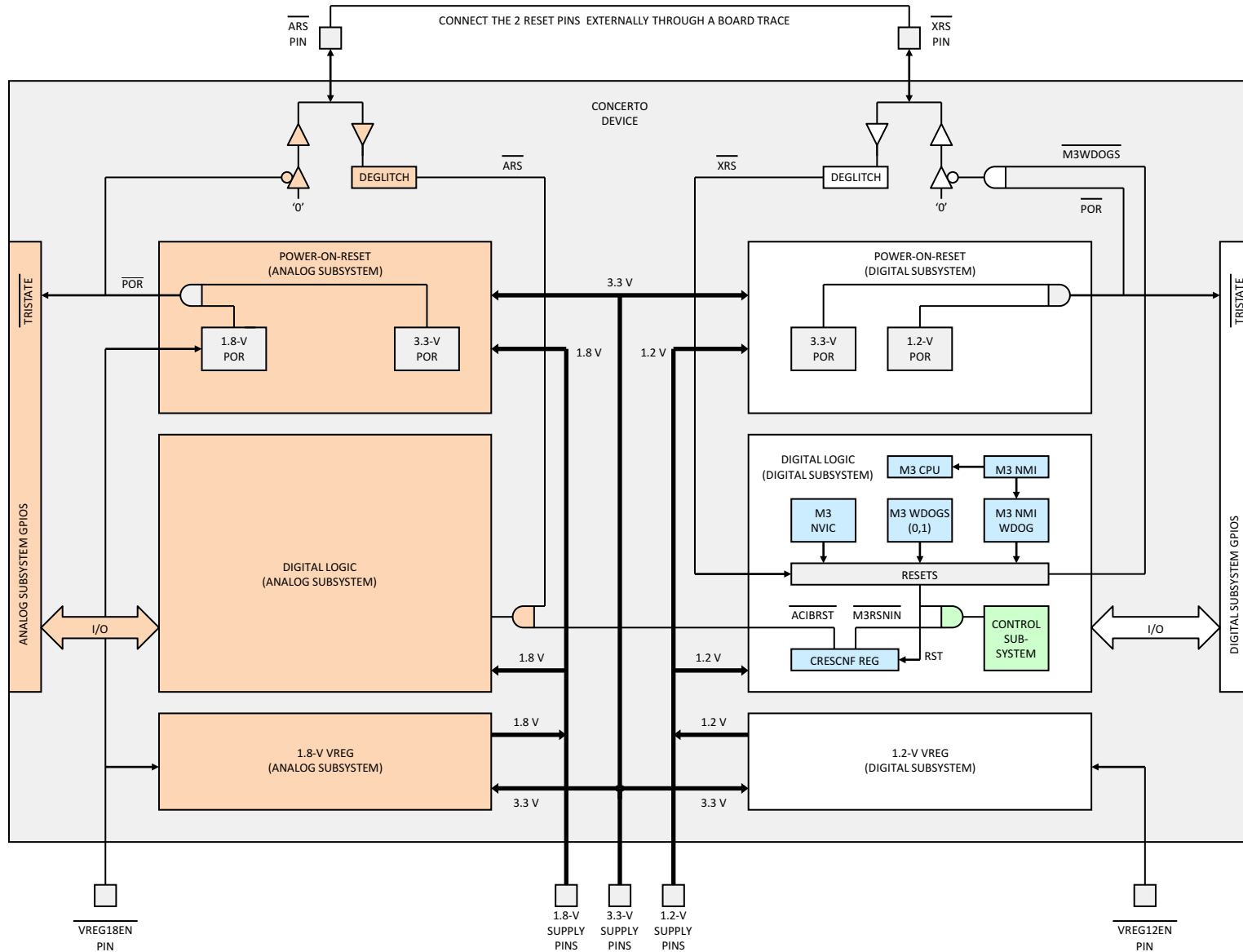

Figure 6-6. Voltage Regulation and Monitoring

### 6.9.2 Digital Subsystem: Internal 1.2-V VREG

The internal 1.2-V VREG generates  $V_{DD12}$  power from  $V_{DDIO}$ . The 1.2-V VREG is enabled by pulling the  $\overline{\text{VREG12EN}}$  pin to a low state. When enabled, the 1.2-V VREG internally provides 1.2 V to digital logic associated with the processors, memory, and peripherals of the Digital Subsystem.

When the internal 1.2-V VREG function is enabled, the 1.2 V power no longer has to be provided externally; however, the minimum and maximum capacitance required for each  $V_{DD12}$  pin to stabilize the internally generated voltages are 250 nF and 750 nF, respectively. These load capacitors are not required if the internal 1.2-V VREG is disabled and the 1.2 V is provided from an external supply.

While removing the need for an external power supply, enabling the internal VREG might affect the  $V_{DDIO}$  power consumption.

### 6.9.3 Analog and Digital Subsystems: Power-On-Reset Functionality

The Analog and Digital Subsystems' each have a POR circuit that creates a clean reset throughout the device enabling glitchless GPIOs during the power-on procedure. The POR function keeps both  $\overline{\text{ARS}}$  and  $\overline{\text{XRS}}$  driven low during device power up. This functionality is always enabled, even when VREG is disabled.

While in most applications, the POR generated reset has a long enough duration to also reset other system ICs, some applications may require a longer lasting pulse. In these cases, the  $\overline{\text{ARS}}$  and  $\overline{\text{XRS}}$  reset pins (which are open-drain) can also be driven low to match the time the device is held in reset state with the rest of the system.

When POR drives the the  $\overline{\text{ARS}}$  and  $\overline{\text{XRS}}$  pins low, the POR also resets the digital logic associated with both subsystems and puts the GPIO pins in a high impedance state.

In addition to the POR reset, the Resets block of the Digital Subsystem also receives reset inputs from the NVIC, the Cortex-M3 Watchdogs (0, 1), and from the Cortex-M3 NMI Watchdog. The resulting reset output signal is then fed back to the  $\overline{\text{XRS}}$  pin after being AND-ed with the POR reset (see [Figure 6-6](#)).

On a related note, only the Master Subsystem comes out of reset state immediately following a device power up. The Control and Analog Subsystems continue to be held in reset until the Master Processor (Cortex-M3) brings them out of reset by writing a "1" to the M3RSNIN and ACIBRST bits of the CRESCNF Register (see [Figure 6-6](#)).

### 6.9.4 Connecting $\overline{\text{ARS}}$ and $\overline{\text{XRS}}$ Pins

In most Concerto applications, TI recommends that the  $\overline{\text{ARS}}$  and  $\overline{\text{XRS}}$  pins be tied together by external means such as through a signal trace on a PCB board. Tying the  $\overline{\text{ARS}}$  and  $\overline{\text{XRS}}$  pins together ensures that all reset sources will cause both the Analog and Digital Subsystems to enter the reset state together, regardless of where the reset condition occurs.

### 6.10 Input Clocks and PLLs

Concerto devices have multiple input clock pins from which all internal clocks and the output clock are derived. Figure 6-7 shows the recommended methods of connecting crystals, resonators, and oscillators to pins X1/X2 and XCLKIN.

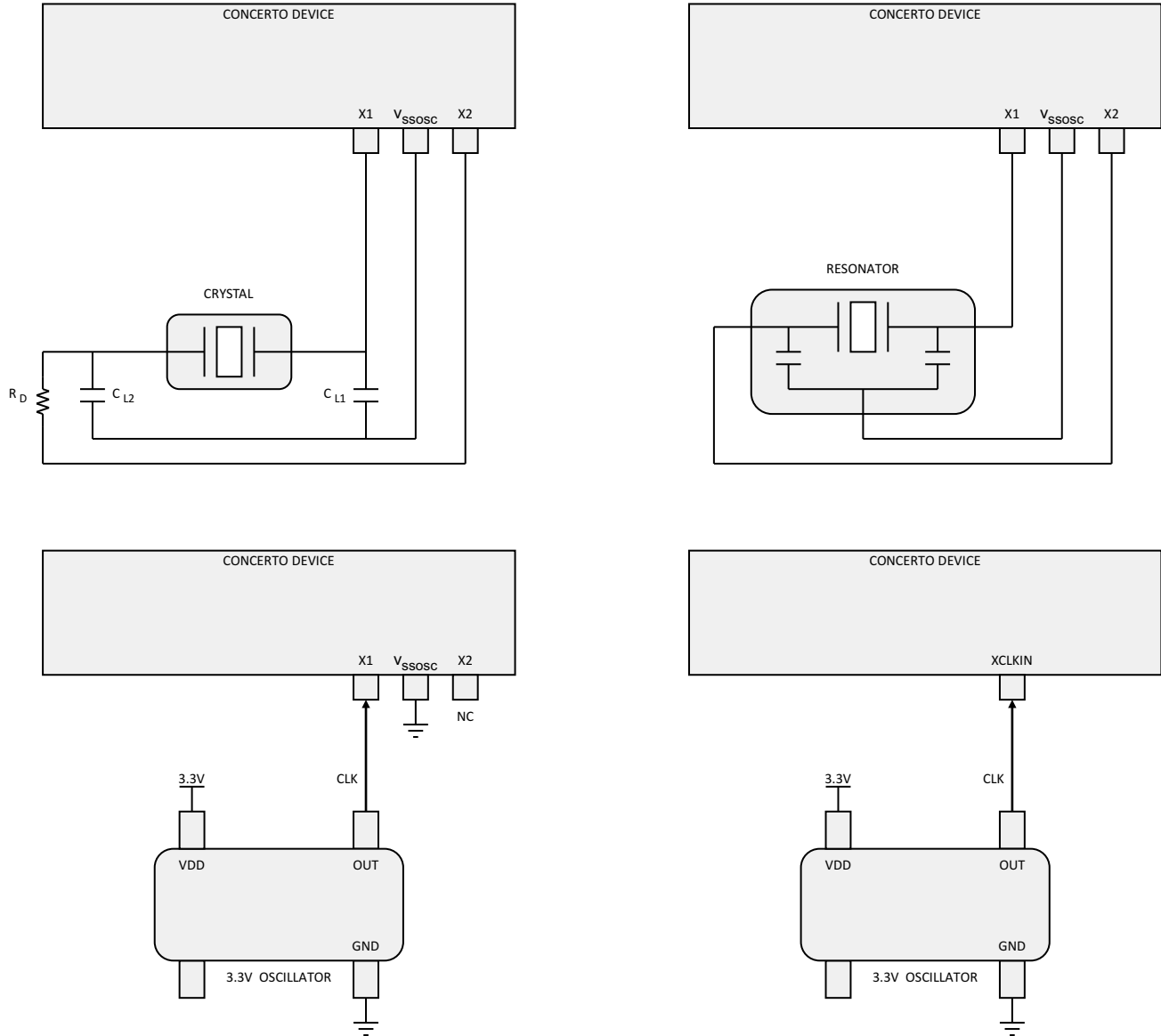

Figure 6-7. Connecting Input Clocks to a Concerto™ Device

### 6.10.1 Internal Oscillator (Zero-Pin)

Each Concerto device contains a zero-pin internal oscillator. This oscillator outputs two fixed-frequency clocks: 10MHZCLK and 32KHZCLK. These clocks are not configurable by the user and should not be used to clock the device during normal operation. They are used inside the Master Subsystem to implement low-power modes. The 10MHZCLK is also used by the Missing Clock Detect circuit.

### 6.10.2 Crystal Oscillator/Resonator (Pins X1/X2 and $V_{SSOSC}$ )

The main oscillator circuit connects to an external crystal through pins X1 and X2. If a resonator is used (version of a crystal with built-in load capacitors), its ground terminal should be connected to the pin  $V_{SSOSC}$  (not board ground). The  $V_{SSOSC}$  pin should also be used to ground the external load capacitors connected to the two crystal terminals as shown in [Figure 6-7](#).

### 6.10.3 External Oscillators (Pins X1 and XCLKIN)

Concerto has two pins (X1 and XCLKIN) into which a single-ended clock can be driven from external oscillators or other clock sources. When connecting an external clock source through the X1 terminal, the X2 terminal should be left unconnected. Most internal clocks of this device are derived from the X1 clock input (or X1/X2 crystal). The XCLKIN clock is only used by the USB PLL and CAN peripherals. [Figure 6-7](#) shows how to connect external oscillators to the X1 and XCLKIN terminals.

Locate the external oscillator as close to the MCU as practical. Ideally, the return ground trace should be an isolated trace directly underneath the forward trace or run adjacent to the trace on the same layer. Spacing should be kept minimal, with any other nearby traces double-spaced away, so that the electromagnetic fields created by the two opposite currents cancel each other out as much as possible, thus reducing parasitic inductances that radiate EMI.

### 6.10.4 Main PLL

The Main PLL uses the reference clock from pins X1 (external oscillator) or X1/X2 (external crystal/resonator). The input clock is multiplied by an integer multiplier and a fractional multiplier as selected by the SPLLMULT and SPLLFMULT fields of the SYSPLLMULT register. For example, to achieve PLL multiply of 28.5, the integer multiplier should be set to 28, and the fractional multiplier to 0.5. The output clock from the Main PLL must be between 150 MHz and 300 MHz. The PLL output clock is then divided by 2 before entering a mux that selects between this clock and the PLL input clock – OSCCLK (used in PLL bypass mode). The PLL bypass mode is selected by setting the SPLLMULT field of the SYSPLLMULT register to 0. The output clock from the mux next enters a divider controlled by the SYSDIVSEL register, after which the output clock becomes the PLLSYCLK. [Figure 6-8](#) shows the Main PLL function and configuration examples. [Table 6-19](#) to [Table 6-22](#) list the integer multiplier configuration values.

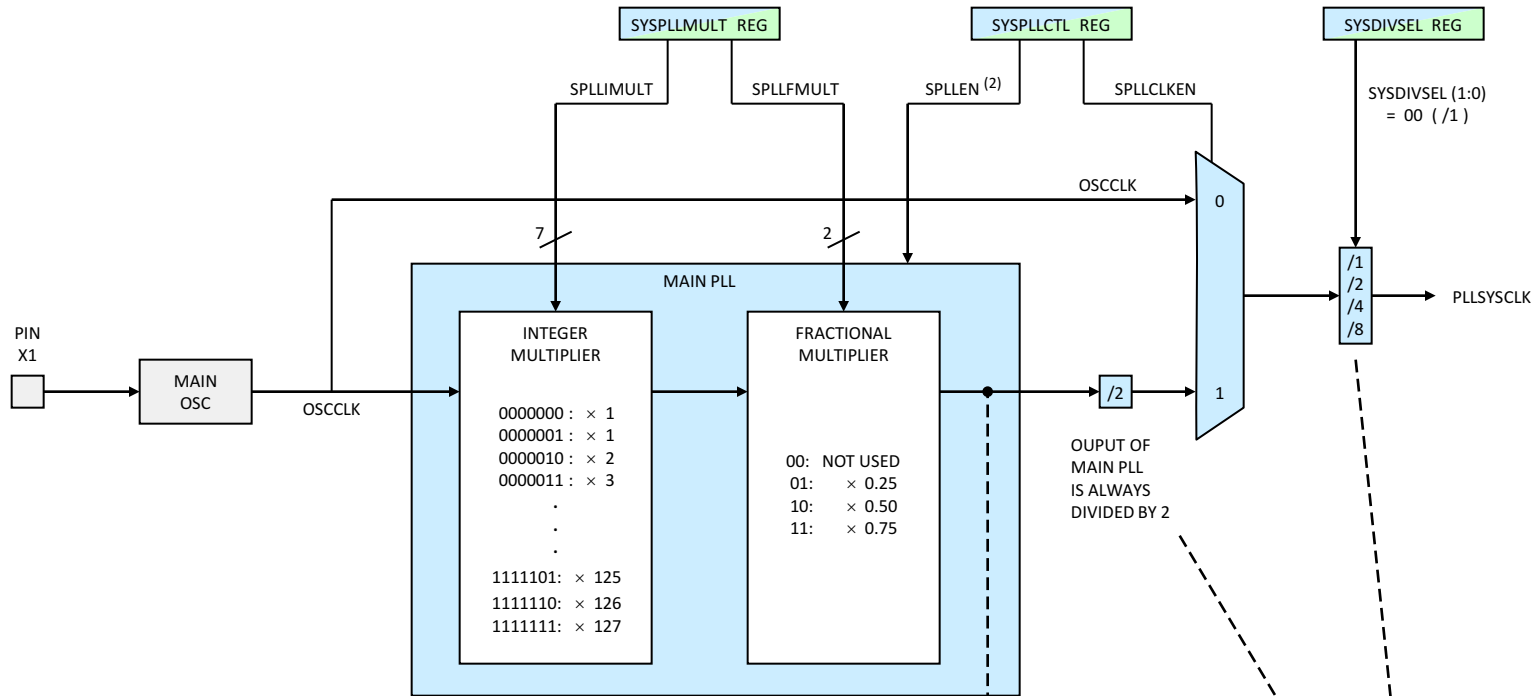

- (1) OUTPUT OF THE MAIN PLL MUST RANGE BETWEEN 150–300 MHz.
- (2) WHEN SPLEN BIT = 0, THE MAIN PLL IS POWERED OFF.

|            |              |                                   |                            |   |
|------------|--------------|-----------------------------------|----------------------------|---|
| EXAMPLE 1: | X1 = 100 MHz | SPLLIMULT = 0000000 ( BYPASS PLL) | N/A                        | PLLSYSCLK = 100 MHz                               |
| EXAMPLE 2: | X1 = 10 MHz  | SPLLIMULT = 0010100 ( × 20 )      | SPLLFMULT = 00 ( NOT USED) | PLLSYSCLK = [ ( 10 × 20 ) / 2 ] / 1 = 100 MHz     |
| EXAMPLE 3: | X1 = 10 MHz  | SPLLIMULT = 0010100 ( × 20 )      | SPLLFMULT = 10 ( × 0.50)   | PLLSYSCLK = [ ( 10 × 20.5 ) / 2 ] / 1 = 102.5 MHz |

Figure 6-8. Main PLL

**Table 6-19. Main PLL Integer Multiplier Configuration  
(Bypass PLL to x 31)**

| SPLLMULT(6:0) | MULT VALUE |
|---------------|------------|
| 0000000 b     | Bypass PLL |
| 0000001 b     | x 1        |
| 0000010 b     | x 2        |
| 0000011 b     | x 3        |
| 0000100 b     | x 4        |
| 0000101 b     | x 5        |
| 0000110 b     | x 6        |
| 0000111 b     | x 7        |
|               |            |
| 0001000 b     | x 8        |
| 0001001 b     | x 9        |
| 0001010 b     | x 10       |
| 0001011 b     | x 11       |
| 0001100 b     | x 12       |
| 0001101 b     | x 13       |
| 0001110 b     | x 14       |
| 0001111 b     | x 15       |
|               |            |
| 0010000 b     | x 16       |
| 0010001 b     | x 17       |
| 0010010 b     | x 18       |
| 0010011 b     | x 19       |
| 0010100 b     | x 20       |
| 0010101 b     | x 21       |
| 0010110 b     | x 22       |
| 0010111 b     | x 23       |
|               |            |
| 0011000 b     | x 24       |
| 0011001 b     | x 25       |
| 0011010 b     | x 26       |
| 0011011 b     | x 27       |
| 0011100 b     | x 28       |
| 0011101 b     | x 29       |
| 0011110 b     | x 30       |
| 0011111 b     | x 31       |

**Table 6-20. Main PLL Integer Multiplier Configuration  
(x 32 to x 63)**

| SPLLMULT(6:0) | MULT VALUE |
|---------------|------------|
| 0100000 b     | x 32       |
| 0100001 b     | x 33       |
| 0100010 b     | x 34       |
| 0100011 b     | x 35       |
| 0100100 b     | x 36       |
| 0100101 b     | x 37       |
| 0100110 b     | x 38       |
| 0100111 b     | x 39       |
|               |            |
| 0101000 b     | x 40       |
| 0101001 b     | x 41       |
| 0101010 b     | x 42       |
| 0101011 b     | x 43       |
| 0101100 b     | x 44       |
| 0101101 b     | x 45       |
| 0101110 b     | x 46       |
| 0101111 b     | x 47       |
|               |            |
| 0110000 b     | x 48       |
| 0110001 b     | x 49       |
| 0110010 b     | x 50       |
| 0110011 b     | x 51       |
| 0110100 b     | x 52       |
| 0110101 b     | x 53       |
| 0110110 b     | x 54       |
| 0110111 b     | x 55       |
|               |            |
| 0111000 b     | x 56       |
| 0111001 b     | x 57       |
| 0111010 b     | x 58       |
| 0111011 b     | x 59       |
| 0111100 b     | x 60       |
| 0111101 b     | x 61       |
| 0111110 b     | x 62       |
| 0111111 b     | x 63       |

**Table 6-21. Main PLL Integer Multiplier Configuration  
(x 64 to x 95)**

| SPLLMULT(6:0) | MULT VALUE |
|---------------|------------|
| 1000000 b     | x 64       |
| 1000001 b     | x 65       |
| 1000010 b     | x 66       |
| 1000011 b     | x 67       |
| 1000100 b     | x 68       |
| 1000101 b     | x 69       |
| 1000110 b     | x 70       |
| 1000111 b     | x 71       |
|               |            |
| 1001000 b     | x 72       |
| 1001001 b     | x 73       |
| 1001010 b     | x 74       |
| 1001011 b     | x 75       |
| 1001100 b     | x 76       |
| 1001101 b     | x 77       |
| 1001110 b     | x 78       |
| 1001111 b     | x 79       |
|               |            |
| 1010000 b     | x 80       |
| 1010001 b     | x 81       |
| 1010010 b     | x 82       |
| 1010011 b     | x 83       |
| 1010100 b     | x 84       |
| 1010101 b     | x 85       |
| 1010110 b     | x 86       |
| 1010111 b     | x 87       |
|               |            |
| 1011000 b     | x 88       |
| 1011001 b     | x 89       |
| 1011010 b     | x 90       |
| 1011011 b     | x 91       |
| 1011100 b     | x 92       |
| 1011101 b     | x 93       |
| 1011110 b     | x 94       |
| 1011111 b     | x 95       |

**Table 6-22. Main PLL Integer Multiplier Configuration  
(x 96 to x 127)**

| SPLLIMULT(6:0) | MULT VALUE |
|----------------|------------|
| 1100000 b      | x 96       |
| 1100001 b      | x 97       |
| 1100010 b      | x 98       |
| 1100011 b      | x 99       |
| 1100100 b      | x 100      |
| 1100101 b      | x 101      |
| 1100110 b      | x 102      |
| 1100111 b      | x 103      |
|                |            |
| 1101000 b      | x 104      |
| 1101001 b      | x 105      |
| 1101010 b      | x 106      |
| 1101011 b      | x 107      |
| 1101100 b      | x 108      |
| 1101101 b      | x 109      |
| 1101110 b      | x 110      |
| 1101111 b      | x 111      |
|                |            |
| 1110000 b      | x 112      |
| 1110001 b      | x 113      |
| 1110010 b      | x 114      |
| 1110011 b      | x 115      |
| 1110100 b      | x 116      |
| 1110101 b      | x 117      |
| 1110110 b      | x 118      |
| 1110111 b      | x 119      |
|                |            |
| 1111000 b      | x 120      |
| 1111001 b      | x 121      |
| 1111010 b      | x 122      |
| 1111011 b      | x 123      |
| 1111100 b      | x 124      |
| 1111101 b      | x 125      |
| 1111110 b      | x 126      |
| 1111111 b      | x 127      |

### 6.10.5 USB PLL

The USB PLL uses the reference clock selectable between the input clock arriving at the XCLKIN pin, or the internal OSCCLK (originating from the external crystal or oscillator through the X1/X2 pins). An input mux selects the source of the USB PLL reference based on the UPLLCLKSRC bit of the UPLLCTL Register (see Figure 6-9). The input clock is multiplied by an integer multiplier and a fractional multiplier as selected by the UPLLIMULT and UPLLFMULT fields of the UPLLMULT register. For example, to achieve PLL multiply of 28.5, the integer multiplier should be set to 28, and the fractional multiplier to 0.5. The output clock from the USB PLL must always be 240 MHz. The PLL output clock is then divided by 4—resulting in 60 MHz that the USB needs—before entering a mux that selects between this clock and the PLL input clock (used in the PLL bypass mode). The PLL bypass mode is selected by setting the UPLLIMULT field of the UPLLMULT register to 0. The output clock from the mux becomes the USBPLLCLK (there is not another clock divider). Figure 6-9 shows the USB PLL function and configuration examples. Table 6-23 and Table 6-24 list the integer multiplier configuration values.

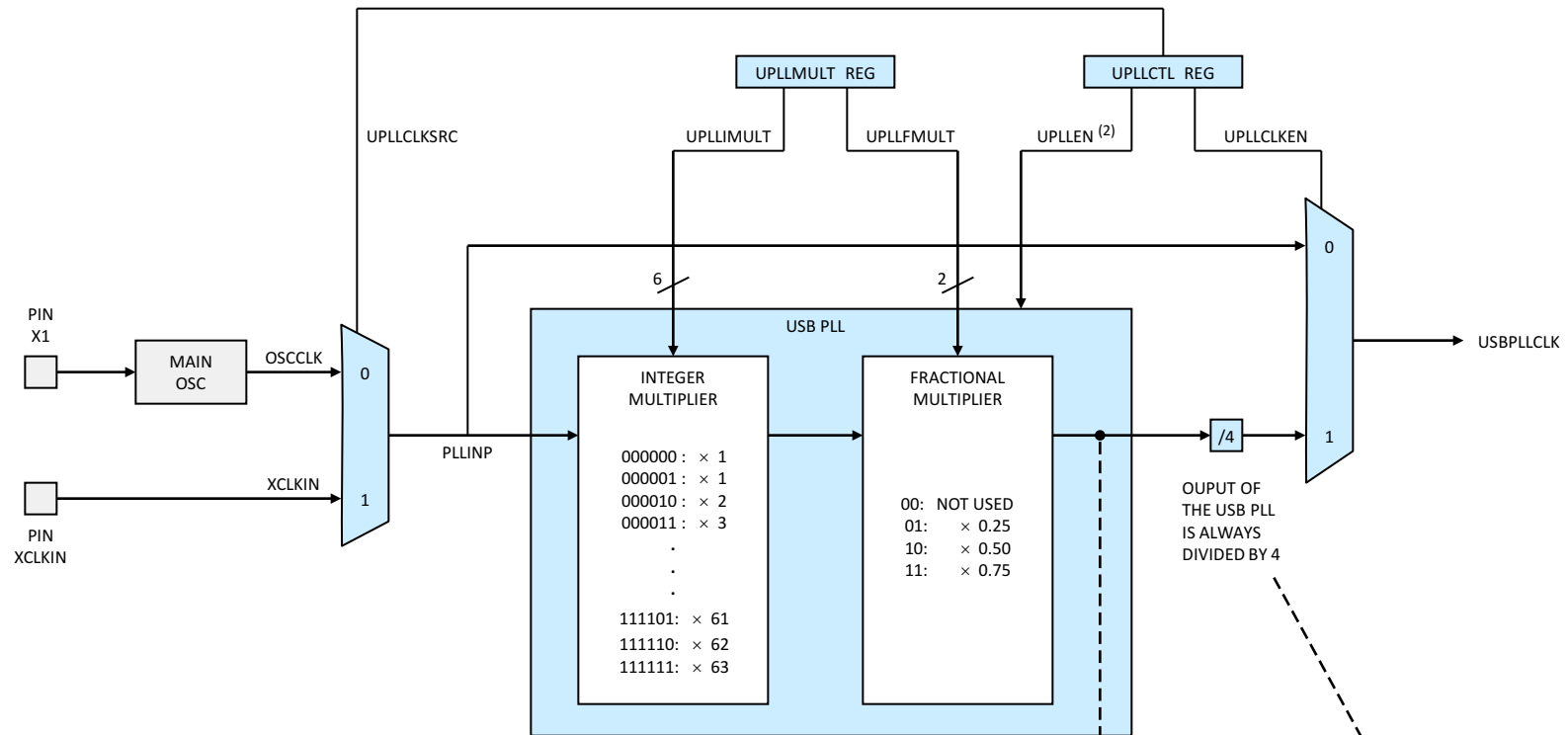

(1) OUTPUT OF THE USB PLL MUST BE ALWAYS 240MHz ( SO THAT USBPLLCLK IS 60MHZ )

(2) WHEN UPLEN BIT = 0, THE USB PLL IS POWERED OFF

|            |                       |                                 |                            |                           |              |
|------------|-----------------------|---------------------------------|----------------------------|---------------------------|--------------|
| EXAMPLE 1: | X1 OR XCLKIN = 60 MHZ | UPLLMULT = 000000 ( BYPASS PLL) | N/A                        | PLLSYSCLK = 60 MHz        |              |
| EXAMPLE 2: | X1 OR XCLKIN = 10 MHZ | UPLLMULT = 011000 ( × 24 )      | UPLLFMULT = 00 ( NOT USED) | PLLSYSCLK = ( 10 × 24 )   | / 4 = 60 MHz |
| EXAMPLE 3: | X1 OR XCLKIN = 64 MHZ | UPLLMULT = 000011 ( × 3)        | UPLLFMULT = 11 ( × 0.75)   | PLLSYSCLK = ( 64 × 3.75 ) | / 4 = 60 MHz |

Figure 6-9. USB PLL

**Table 6-23. USB PLL Integer Multiplier Configuration  
(Bypass PLL to x 31)**

| SPLLIMULT(5:0) | MULT VALUE |
|----------------|------------|
| 000000 b       | Bypass PLL |
| 000001 b       | x 1        |
| 000010 b       | x 2        |
| 000011 b       | x 3        |
| 000100 b       | x 4        |
| 000101 b       | x 5        |
| 000110 b       | x 6        |
| 000111 b       | x 7        |
|                |            |
| 001000 b       | x 8        |
| 001001 b       | x 9        |
| 001010 b       | x 10       |
| 001011 b       | x 11       |
| 001100 b       | x 12       |
| 001101 b       | x 13       |
| 001110 b       | x 14       |
| 001111 b       | x 15       |
|                |            |
| 010000 b       | x 16       |
| 010001 b       | x 17       |
| 010010 b       | x 18       |
| 010011 b       | x 19       |
| 010100 b       | x 20       |
| 010101 b       | x 21       |
| 010110 b       | x 22       |
| 010111 b       | x 23       |
|                |            |
| 011000 b       | x 24       |
| 011001 b       | x 25       |
| 011010 b       | x 26       |
| 011011 b       | x 27       |
| 011100 b       | x 28       |
| 011101 b       | x 29       |
| 011110 b       | x 30       |
| 011111 b       | x 31       |

**Table 6-24. USB PLL Integer Multiplier Configuration  
(x 32 to x 63)**

| SPLLIMULT(5:0) | MULT VALUE |
|----------------|------------|
| 100000 b       | x 32       |
| 100001 b       | x 33       |
| 100010 b       | x 34       |
| 100011 b       | x 35       |
| 100100 b       | x 36       |
| 100101 b       | x 37       |
| 100110 b       | x 38       |
| 100111 b       | x 39       |
|                |            |
| 101000 b       | x 40       |
| 101001 b       | x 41       |
| 101010 b       | x 42       |
| 101011 b       | x 43       |
| 101100 b       | x 44       |
| 101101 b       | x 45       |
| 101110 b       | x 46       |
| 101111 b       | x 47       |
|                |            |
| 110000 b       | x 48       |
| 110001 b       | x 49       |
| 110010 b       | x 50       |
| 110011 b       | x 51       |
| 110100 b       | x 52       |
| 110101 b       | x 53       |
| 110110 b       | x 54       |
| 110111 b       | x 55       |
|                |            |
| 111000 b       | x 56       |
| 111001 b       | x 57       |
| 111010 b       | x 58       |
| 111011 b       | x 59       |
| 111100 b       | x 60       |
| 111101 b       | x 61       |
| 111110 b       | x 62       |
| 111111 b       | x 63       |

## 6.11 Master Subsystem Clocking

The internal PLLSYSCLK clock, normally used as a source for all Master Subsystem clocks, is a divided-down output of the Main PLL or X1 external clock input, as defined by the SPLLCKEN bit of the SYSPLLCTL register.

There is also a second oscillator that internally generates two clocks: 32KHZCLK and 10MHZCLK. The 10MHZCLK is used by the Missing Clock Circuit to detect a possible absence of an external clock source to the Main Oscillator that drives the Main PLL. Detection of a missing clock results in a substitution of the 10MHZCLK for the PLLSYSCLK. The CLKFAIL signal is also sent to the NMI Block and the Control Subsystem where this signal can trip the ePWM peripherals.

The 32KHZCLK and 10MHZCLK clocks are also used by the Cortex-M3 Subsystem as possible sources for the Deep Sleep Clock.

There are four registers associated with the Main PLL: SYSPLLCTL, SYSPLLMULT, SYSPLLSTAT and SYSDIVSEL. Typically, the Cortex-M3 processor writes to these registers, while the C28x processor has read access. The C28x can request write access to the above registers through the CLKREQUEST register. Cortex-M3 can regain write ownership of these registers through the MCLKREQUEST register.

The Master Subsystem operates in one of three modes: Run Mode, Sleep Mode, or Deep Sleep Mode. [Table 6-25](#) shows the Master Subsystem low-power modes and their effect on both CPUs, clocks, and peripherals. [Figure 6-10](#) shows the Cortex-M3 clocks and the Master Subsystem low-power modes.

**Table 6-25. Master Subsystem Low-Power Modes**

| Cortex-M3 LOW-POWER MODE | STATE OF Cortex-M3 CPU | CLOCK TO Cortex-M3 PERIPHERALS | REGISTER USED TO GATE CLOCKS TO Cortex-M3 PERIPHERALS | MAIN PLL | USB PLL | CLOCK TO C28x            | CLOCK TO SHARED RESOURCES | CLOCK TO ANALOG SUBSYSTEM |
|--------------------------|------------------------|--------------------------------|---|----------|---------|--------------------------|---------------------------|---------------------------|
| Run                      | Active                 | M3SSCLK <sup>(1)</sup>         | RCGC  | On       | On      | PLLSYSCLK <sup>(2)</sup> | PLLSYSCLK <sup>(2)</sup>  | ASYSCLK <sup>(3)</sup>    |
| Sleep                    | Stopped                | M3SSCLK <sup>(1)</sup>         | RCGC or SCGC <sup>(4)</sup>                           | On       | On      | PLLSYSCLK <sup>(2)</sup> | PLLSYSCLK <sup>(2)</sup>  | ASYSCLK <sup>(3)</sup>    |
| Deep Sleep               | Stopped                | M3DSDIVCLK <sup>(5)</sup>      | RCGC or DCGC <sup>(4)</sup>                           | Off      | Off     | Off                      | Off                       | Off                       |

- (1) PLLSYSCLK or OSCCLK divided-down per the M3SSDIVSEL register. In case of a missing source clock, M3SSCLK becomes 10MHZCLK divided-down per the M3SSDIVSEL register.
- (2) PLLSYSCLK normally refers to the output of the Main PLL divided-down per the SYSDIVSEL register. In case the PLL is bypassed, the PLLSYSCLK becomes the OSCCLK divided-down per the SYSDIVSEL register. In case of a missing source clock, the 10MHZCLK is substituted for the PLLSYSCLK.
- (3) PLLSYSCLK or OSCCLK divided-down per the CCLKCTL register. In case of a missing source clock, ASYSCLK becomes 10MHZCLK.
- (4) Depends on the ACG bit of the RCC register.
- (5) 32KHZCLK or 10MHZCLK or OSCCLK chosen/divided-down per the DSLPCLKCFG register, then again divided by the M3SSDIVSEL register (source determined inside the DSLPCLKCFG register).

[Figure 6-11](#) shows the system clock/PLL.

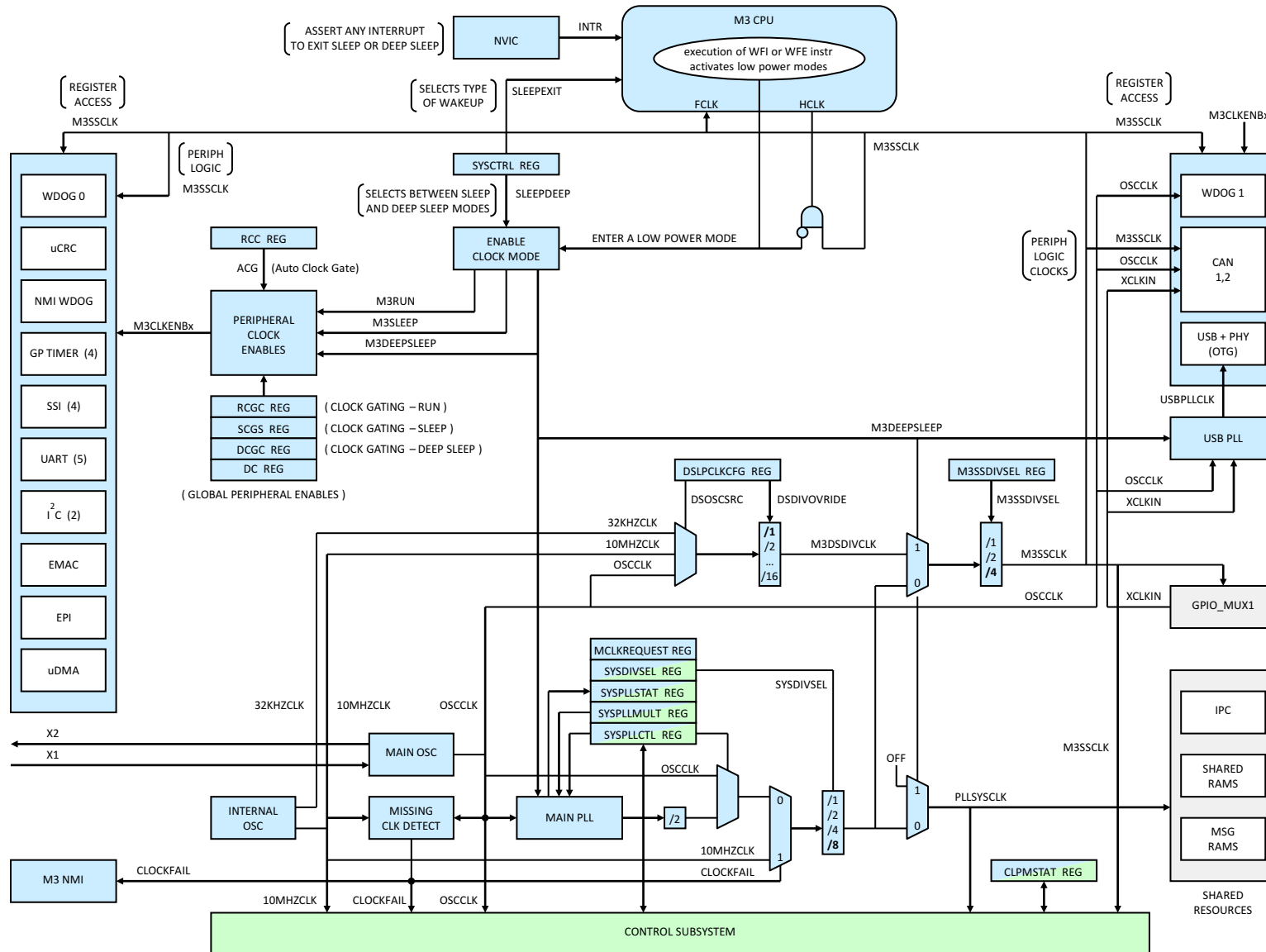

Figure 6-10. Cortex-M3 Clocks and Low-Power Modes

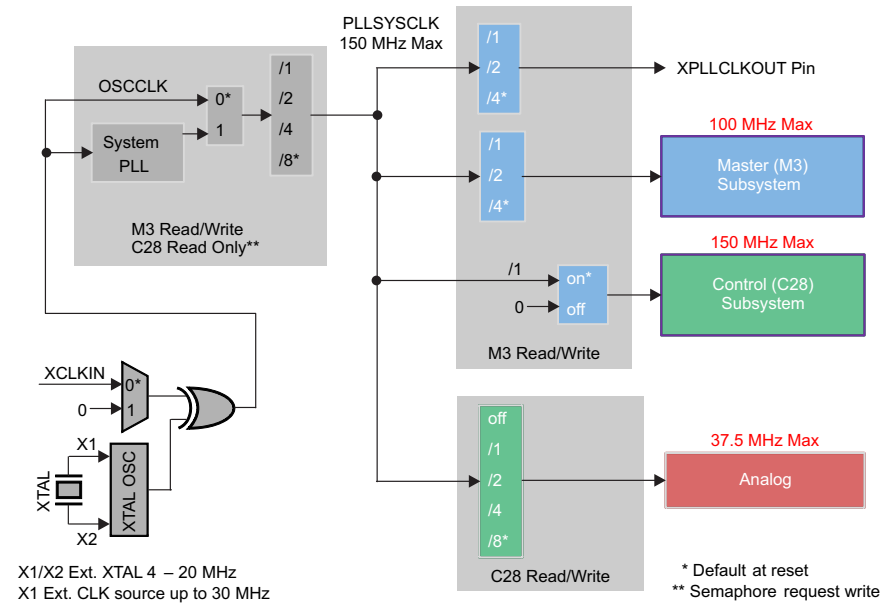

Figure 6-11. System Clock/PLL

### 6.11.1 Cortex-M3 Run Mode

In Run Mode, the Cortex-M3 processor, memory, and most of the peripherals are clocked by the M3SSCLK, which is a divide-down version of the PLLSYSCLK (from Main PLL). The USB is clocked from a dedicated USB PLL, the CAN peripherals are clocked by M3SSCLK, OSCCLK, or XCLKIN, and one of two watchdogs (WDOG1) is also clocked by the OSCCLK. Clock selection for these peripherals is accomplished through corresponding peripheral configuration registers. Clock gating for individual peripherals is defined inside the RCGS register. RCGS, SCGS, and DCGS clock-gating settings only apply to peripherals that are enabled in a corresponding DC (Device Configuration) register.

Execution of the WFI instruction (Wait-for-Interrupt) shuts down the HCLK to the Cortex-M3 CPU and forces the Cortex-M3 Subsystem into Sleep or Deep Sleep low-power mode, depending on the state of the SLEEPDEEP bit of the Cortex-M3 SYSCTRL register. To come out of a low-power mode, any properly configured interrupt event terminates the Sleep or Deep Sleep Mode and returns the Cortex-M3 processor/subsystem to Run Mode.

### 6.11.2 Cortex-M3 Sleep Mode

In Sleep Mode, the Cortex-M3 processor and memory are prevented from clocking, and thus the code is no longer executing. The gating for the peripheral clocks may change based on the ACG bit of the RCC register. When ACG = 0, the peripheral clock gating is used as defined by the RCGS registers (same as in Run Mode); and when ACG = 1, the clock gating comes from the SCGS register. RCGS and SCGS clock-gating settings only apply to peripherals that are enabled in a corresponding DC register. Peripheral clock frequency for the enabled peripherals in Sleep Mode is the same as during the Run Mode.

Sleep Mode is terminated by any properly configured interrupt event. Exiting from the Sleep Mode depends on the SLEEPEXIT bit of the SYSCTRL register. When the SLEEPEXIT bit is 1, the processor will temporarily wake up only for the duration of the ISR of the interrupt causing the wake-up. After that, the processor goes back to Sleep Mode. When the SLEEPEXIT bit is 0, the processor wakes up permanently (for the ISR and thereafter).

### 6.11.3 Cortex-M3 Deep Sleep Mode

In Deep Sleep Mode, the Cortex-M3 processor and memory are prevented from clocking and thus the code is no longer executing. The Main PLL, USB PLL, ASYSCLK to the Analog Subsystem, and input clock to the C28x CPU and Shared Resources are turned off. The gating for the peripheral clocks may change based on the ACG bit of the RCC register. When ACG = 0, the peripheral clock gating is used as defined by the RCGS registers (same as in Run Mode); and when ASC = 1, the clock gating comes from the DCGS register. RCGS and DCGS clock gating settings only apply to peripherals that are enabled in a corresponding DC register.

Peripheral clock frequency for the enabled peripherals in Deep Sleep Mode is different from the Run Mode. One of three sources for the Deep Sleep clocks (32KHZCLK, 10MHZCLK, or OSCCLK) is selected with the DSOSCSRC bits of the DSLPCLKCFG register. This clock is divided-down according to DSDIVOVERRIDE bits of the DSLPCLKCFG register. The output of this Deep Sleep Divider is further divided-down per the M3SSDIVSEL bits of the D3SSDIVSEL register to become the Deep Sleep Clock. If 32KHXCLK or 10MHZCLK is selected in Deep Sleep mode, the internal oscillator circuit (that generates OSCCLK) is turned off.

The Cortex-M3 processor should enter the Deep Sleep mode only after first confirming that the C28x is already in the STANDBY mode. Typically, just before entering the STANDBY mode, the C28x will record in the CLPMSTAT that it is about to do so. The Cortex-M3 processor can read the CLPMSTAT register to check if the C28x is in STANDBY mode, and only then should the Cortex-M3 processor go into Deep Sleep. The reason for the Cortex-M3 processor to confirm that the C28x is in STANDBY mode before the Cortex-M3 processor enters the Deep Sleep mode is that the Deep Sleep mode shuts down the clock to C28x and its peripherals, and if this clock shutdown is not expected by the C28x, unintended consequences could result for some of the C28x control peripherals.

Deep Sleep Mode is terminated by any properly configured interrupt event. Exiting from the Deep Sleep Mode depends on the SLEEPEXIT bit of the SYSCTRL register. When the SLEEPEXIT bit is 1, the processor will temporarily wake up only for the duration of the ISR of the interrupt causing the wake-up. After that, the processor goes back to Deep Sleep Mode. When the SLEEPEXIT bit is 0, the processor wakes up permanently (for the ISR and thereafter).

## 6.12 Control Subsystem Clocking

The CLKIN input clock to the C28x processor is normally a divided-down output of the Main PLL or X1 external clock input. There are four registers associated with the Main PLL: SYSPLLCTL, SYSPLLMULT, SYSPLLSTAT and SYSDIVSEL. Typically, the Cortex-M3 processor writes to these registers, while the C28x processor has read access. The C28x can request write access to the above registers through the CLKREQUEST register. The Cortex-M3 can regain write ownership of these registers through the MCLKREQUEST register.

Individual C28x peripherals can be turned on or off by gating C28SYSCLK to those peripherals, which is done through the CPCLKCR0,2,3 registers.

The C28x processor outputs two clocks: C28CPUCLK and C28SYSCLK. The C28SYSCLK is used by C28x peripherals, C28x Timer 0, C28x Timer 1, and C28x Timer 2. C28x Timer 2 can also be clocked by OSCCLK or 10MHZCLK (see [Figure 6-12](#)). The C28CPUCLK is used by the C28x CPU, FPU, VCU, and PIE.

The Control Subsystem operates in one of three modes: Normal Mode, IDLE Mode, or STANDBY Mode. [Table 6-26](#) shows the Control Subsystem low-power modes and their effect on the C28x CPU, clocks, and peripherals. [Figure 6-12](#) shows the Control Subsystem clocks and low-power modes.

**Table 6-26. Control Subsystem Low-Power Modes<sup>(1)</sup>**

| C28x LOW-POWER MODE | STATE OF C28x CPU | C28CPUCLK <sup>(2)</sup> | C28SYSCLK <sup>(3)</sup> | REGISTERS USED TO GATE CLOCKS TO C28x PERIPHERALS |
|---------------------|-------------------|--------------------------|--------------------------|---|
| Normal              | Active            | On                       | On                       | CPCLKCR0,1,3                                      |
| IDLE                | Stopped           | Off                      | On                       | CPCLKCR0,1,3                                      |
| STANDBY             | Stopped           | Off                      | Off                      | N/A   |

(1) The input clock to the C28x CPU is PLLSYSCLK from the Master Subsystem. This clock is turned off when the Master Subsystem enters the Deep Sleep mode.

(2) C28CPUCLK is an output from the C28x CPU. C28CPUCLK clocks the C28x FPU, VCU, and PIE.

(3) C28SYSCLK is an output from the C28x CPU. C28SYSCLK clocks C28x peripherals.

### 6.12.1 C28x Normal Mode

In Normal Mode, the C28x processor, Local Memory, and C28x peripherals are clocked by the C28SYSCLK, which is derived from the C28CLKIN input clock to the C28x processor. The FPU, VCU, and PIE are clocked by the C28CPUCLK, which is also derived from the C28CLKIN. Timer 2 can also be clocked by the TMR2CLK, which is a divided-down version of one of three source clocks—C28SYSCLK, OSCCLK, and 10MHZCLK—as selected by the CLKCTL register. Additionally, the LOSPCP register can be programmed to provide a dedicated clock (C28LSPCLK) to the SCI, SPI, and McBSP peripherals.

Clock gating for individual peripherals is defined inside the CPCLKCR0,1,3 registers. Execution of the IDLE instruction stops the C28x processor from clocking and activates the IDLES signal. The IDLES signal is gated with two LPM bits of the CPCLKCR0 register to enter the C28x Subsystem into IDLE mode or STANDBY Mode.

### 6.12.2 C28x IDLE Mode

In IDLE Mode, the C28x processor stops executing instructions and the C28CPUCLK is turned off. The C28SYSCLK continues to run. Exit from IDLE Mode is accomplished by any enabled interrupt or the C28NMIINT (C28x nonmaskable interrupt).

Upon exit from IDLE Mode, the C28CPUCLK is restored. If LPMWAKE interrupt is enabled, the LPMWAKE ISR is executed. Next, the C28x processor starts fetching instructions from a location immediately following the IDLE instruction that originally triggered the IDLE Mode.



### 6.12.3 C28x STANDBY Mode

In STANDBY Mode, the C28x processor stops executing instructions and the C28CLKIN, C28CPUCLK, and C28SYSCLK are turned off. Exit from STANDBY Mode is accomplished by 1 of 62 GPIOs from the GPIO\_MUX1 block, or MTOCIPCINT2 (interrupt from MTOC IPC peripheral). The wakeup GPIO selected inside the GPIO\_MUX block enters the Qualification Block as the LPMWAKE signal. Inside the Qualification Block, the LPMWAKE signal is sampled per the QUALSTDBY bits (bits [7:2] of the CPCLKCR0 register) before propagating into the wake request logic.

Cortex-M3 should use CLPMSTAT register bits to tell the C28x to go into STANDBY mode before going into Deep Sleep mode. Otherwise, the clock to the C28x will be turned off suddenly when the control software is not expecting this clock to shut off. When the device is in Deep Sleep/STANDBY mode, wake-up should happen only from the Master Subsystem, because all C28x clocks are off (C28CLKIN, C28CPUCLK, C28SYSCLK), thus preventing the C28x from waking up first.

Upon exit from STANDBY Mode, the C28CLKIN, C28SYSCLK, and C28CPUCLK are restored. If the LPMWAKE interrupt is enabled, the LPMWAKE ISR is executed. Next, the C28x processor starts fetching instructions from a location immediately following the IDLE instruction that originally triggered the STANDBY Mode.

---

#### NOTE

For GPIO\_MUX1 pins PF6\_GPIO38 and PG6\_GPIO46, only the corresponding USB function is available on silicon revision 0 devices (GPIO and other functions listed in [Table 4-1](#) are not available).

---

### 6.13 Analog Subsystem Clocking

The Analog Subsystem is clocked by ASYSCLK, which is a divided-down version of the PLLSYSCLK as defined by CLKDIV bits of the CCLKCTL register. The CCLKCTL register is exclusively accessible by the C28x processor. The CCLKCTL register is reset by  $\overline{\text{ASYSRST}}$ , which is derived from two Analog Subsystem resets— $\overline{\text{ACIBRST}}$  and  $\overline{\text{SRXRST}}$ . Therefore, while normally the C28x controls the frequency of ASYSCLK, it is possible for the Cortex-M3 software to restore the ASYSCLK to its default value by resetting the Analog Subsystem.

The ASYSCLK is shut down when the Cortex-M3 processor enters the Deep Sleep mode.

### 6.14 Shared Resources Clocking

The IPC, Shared RAMs, and Message RAMs are clocked by PLLSYSCLK. EPI is clocked by M3SSCLK. The PLLSYSCLK normally refers to the output of the Main PLL divided-down per the SYSDIVSEL register. In case the PLL is bypassed, the PLLSYSCLK becomes the OSCCLK divided-down per the SYSDIVSEL register. In case of a missing source clock, the 10MHZCLK is substituted for the PLLSYSCLK.

Although EPI is a shared peripheral, it is physically located inside the Cortex-M3 Subsystem; therefore, EPI is clocked by M3SSCLK.

### 6.15 Loss of Input Clock (NMI Watchdog Function)

The Concerto devices use two type of input clocks. The main clock, for clocking most of the digital logic of the Master, Control, and Analog subsystems, enters the chip through pins X1 and X2 when using external crystal or just pin X1 when using an external oscillator. The second clock enters the chip through the XCLKIN pin and this second clock can be used to clock the USB PLL and CAN peripherals. Only the main clock has a built-in Missing Clock Detection circuit to recognize when the clock source vanishes and to enable other chip components to take corrective or recovery action from such event (see [Figure 6-13](#)).

The Missing Clock Detection circuit itself is clocked by the 10MHZCLK (from an internal zero-pin oscillator) so that, if the main clock disappears, the circuit is still working. Immediately after detecting a missing source clock, the Missing Clock Detection circuit outputs the CLOCKFAIL signal to the Cortex-M3 NMI circuit, the C28x NMI, ePWM peripherals, and the PLLSYSCLK mux. When the PLLSYSCLK mux senses an active CLOCKFAIL signal, the PLLSYSCLK mux revives the PLLSYSCLK using the 10MHZCLK. Simultaneously, the ePWM peripherals can use the CLOCKFAIL signal to stop down driving motor control outputs. The NMI blocks respond to the CLOCKFAIL signal by sending an NMI interrupt to a corresponding CPU, while starting the associated NMI watchdog counter.

If the software does not respond to the clock-fail condition, the watchdog timers will overflow, resulting in the device reset. If the software does react to the NMI, the software can prevent the impending reset by disabling the watchdog timers, and then the software can initiate necessary corrective action such as switching over to an alternative clock source (if available) or the software can initiate a shut-down procedure for the system.

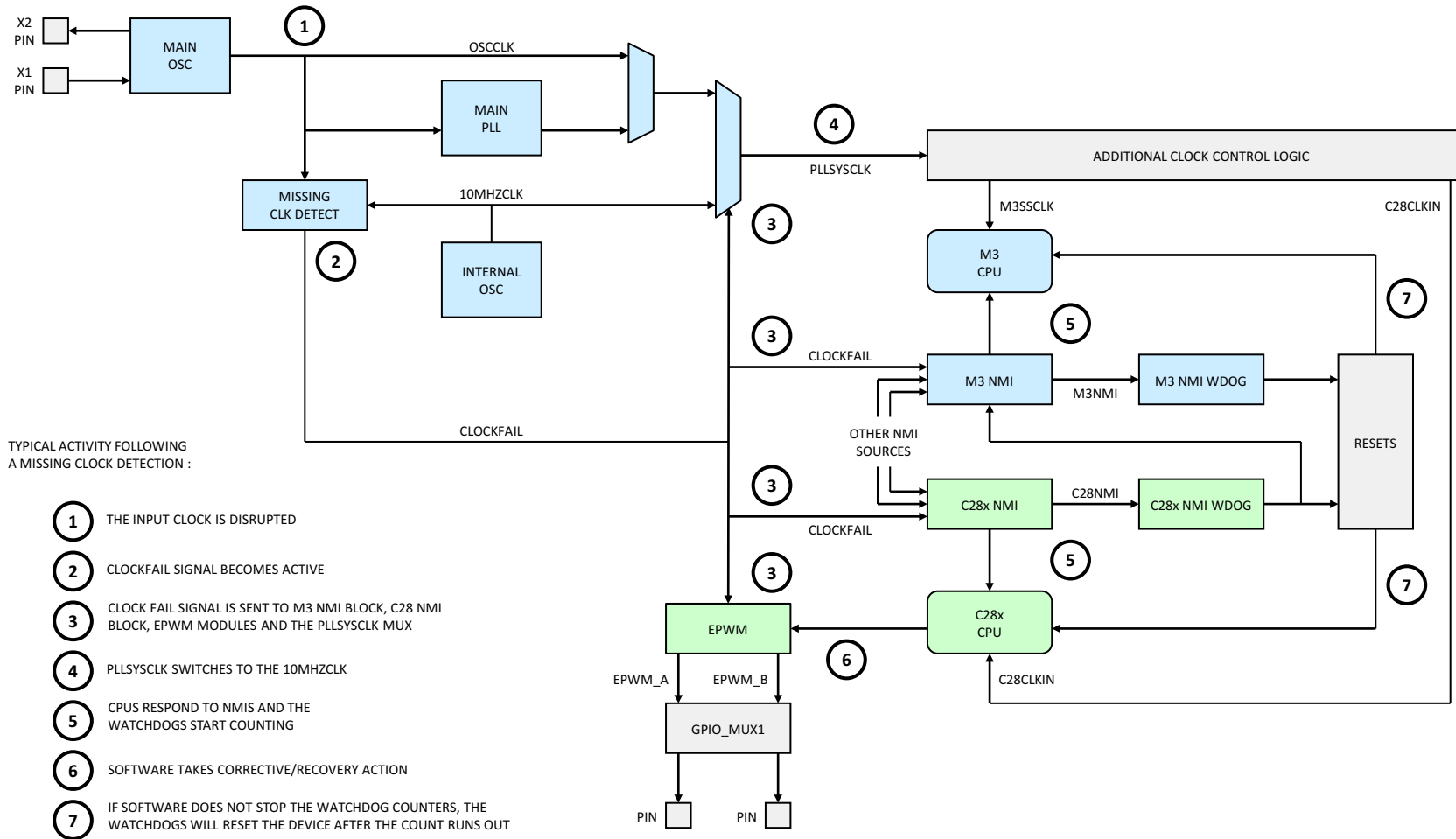

Figure 6-13. Missing Clock Detection

## 6.16 GPIOs and Other Pins

Most Concerto external pins are shared among many internal peripherals. This sharing of pins is accomplished through several I/O muxes where a specific physical pin can be assigned to selected signals of internal peripherals.

Most of the I/O pins of the Concerto MCU can also be configured as programmable GPIOs. Exceptions include the X1 and X2 oscillator inputs; the  $\overline{XRS}$  digital reset and  $\overline{ARS}$  analog reset; the  $\overline{VREG12EN}$  and  $\overline{VREG18EN}$  internal voltage regulator enables; and five JTAG pins. The 74 primary GPIOs are grouped in 2 programmable blocks: GPIO\_MUX1 block (66 pins) and GPIO\_MUX2 block (8 pins). Additionally, eight secondary GPIOs are available through the AIO\_MUX1 block (four pins) and AIO\_MUX2 block (four pins). [Figure 6-14](#) shows the GPIOs and other pins.

### 6.16.1 GPIO\_MUX1

Sixty-six pins of the GPIO\_MUX1 block can be selectively mapped through corresponding sets of registers to all Cortex-M3 peripherals, to all C28x peripherals, to 66 General-Purpose Inputs, to 66 General-Purpose Outputs, or a mixture of all of the above. Sixty-two pins of GPIO\_MUX1 (GPIO0–GPIO63 minus GPIO39 and GPIO44) can also be mapped to 12 ePWM Trip Inputs, 6 eCAP inputs, 3 External Interrupts to the C28x PIE, and the C28x STANDBY Mode Wakeup signal (LMPWAKE). Additionally, each GPIO\_MUX1 pin can have a pullup enabled or disabled. By default, all pullups and outputs are disabled on reset, and all pins of the GPIO\_MUX1 block are mapped to Cortex-M3 peripherals (and not to C28x peripherals).

[Figure 6-15](#) shows the internal structure of GPIO\_MUX1. The blue blocks represent the Master Subsystem side of GPIO\_MUX1, and the green blocks are the Control Subsystem side. The grey block in the center, Pin-Level Mux, is where the GPIO\_MUX1 pins are individually assigned between the two subsystems, based on how the configuration registers are programmed in the blue and green blocks (see [Figure 6-16](#) for the configuration registers).

Pin-Level Mux assigns Master Subsystem peripheral signals, Control Subsystem peripheral signals, or GPIOs to the 66 GPIO\_MUX1 pins. In addition to connecting peripheral I/Os of the two subsystems to pins, the Pin-Level Mux also provides other signals to the subsystems: XCLKIN and GPIO[A:J] IRQ signals to the Master Subsystem, plus GPTRIP[12:1] and GPI[63:0] signals to the Control Subsystem. XCLKIN carries a clock from an external pin to USB PLL and CAN modules. The nine GPIO[A:J] IRQ signals are interrupt requests from selected external pins to the NVIC interrupt controller. The 12 GPTRIP[12:1] signals carry trip events from selected external pins to C28x control peripherals—ePWM, eCAP, and eQEP. Sixty-four GPI signals go to the C28x LPM GPIO Select block where one of them can be selected to wake up the C28x CPU from Low-Power Mode. Sixty-six (66) GPI signals go to the C28x QUAL block where they can be configured with a qualification sampling period (see [Figure 6-16](#)).

The configuration registers for the muxing of Master Subsystem peripherals are organized in nine sets (A–J), with each set being responsible for eight pins. These nine sets of registers are programmable by the Cortex-M3 CPU through the AHB bus or the APB bus. The configuration register for the muxing of Control Subsystem peripherals are organized in three sets (A–C), with each set being responsible for up to 32 pins. These registers are programmable by the C28x CPU through the C28x CPU bus. [Figure 6-16](#) shows set A of the Master Subsystem GPIO configuration registers, set A of the Control Subsystem registers, and the muxing logic for one GPIO pin as driven by these registers.



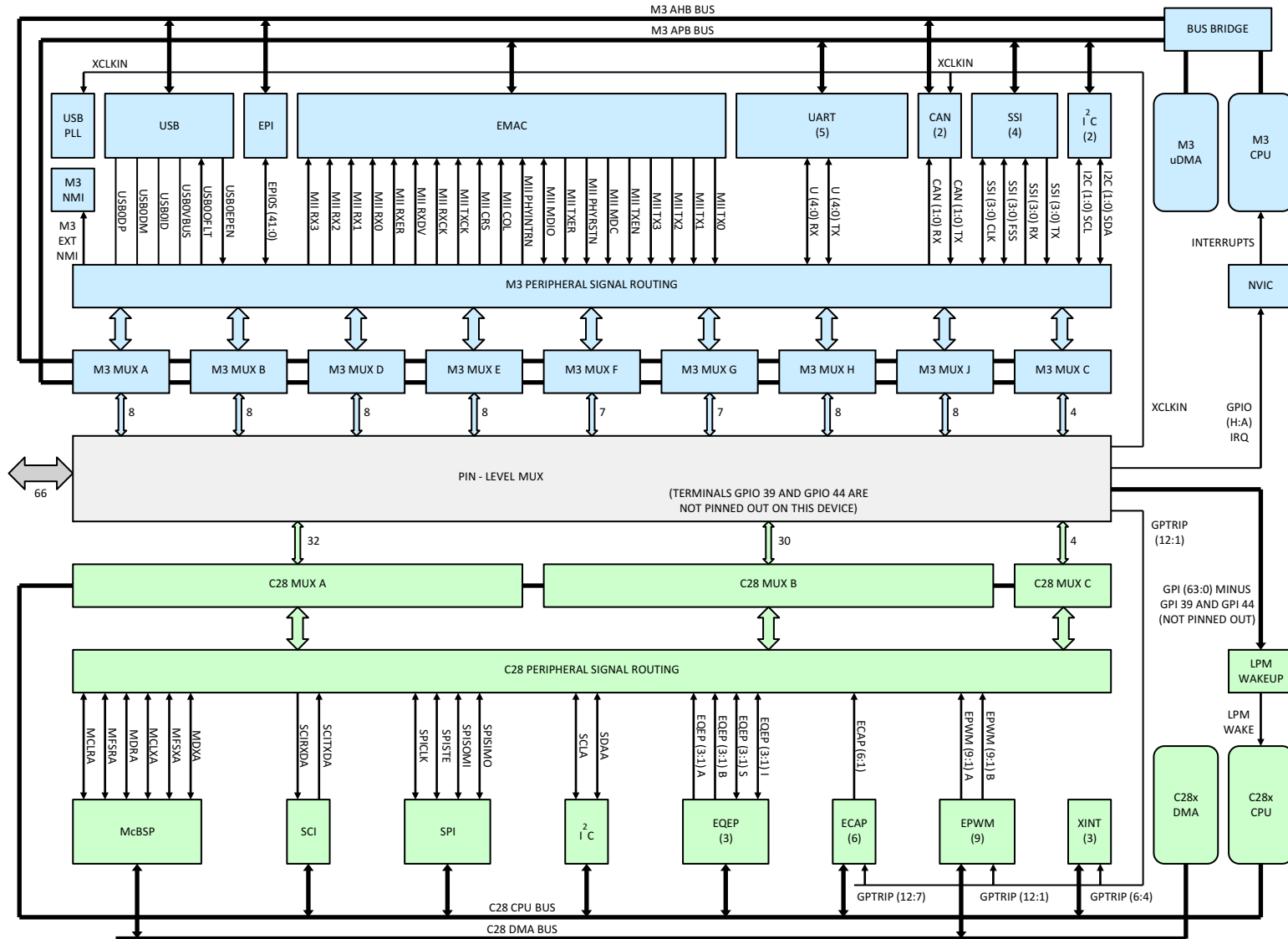

Figure 6-15. GPIO\_MUX1 Block

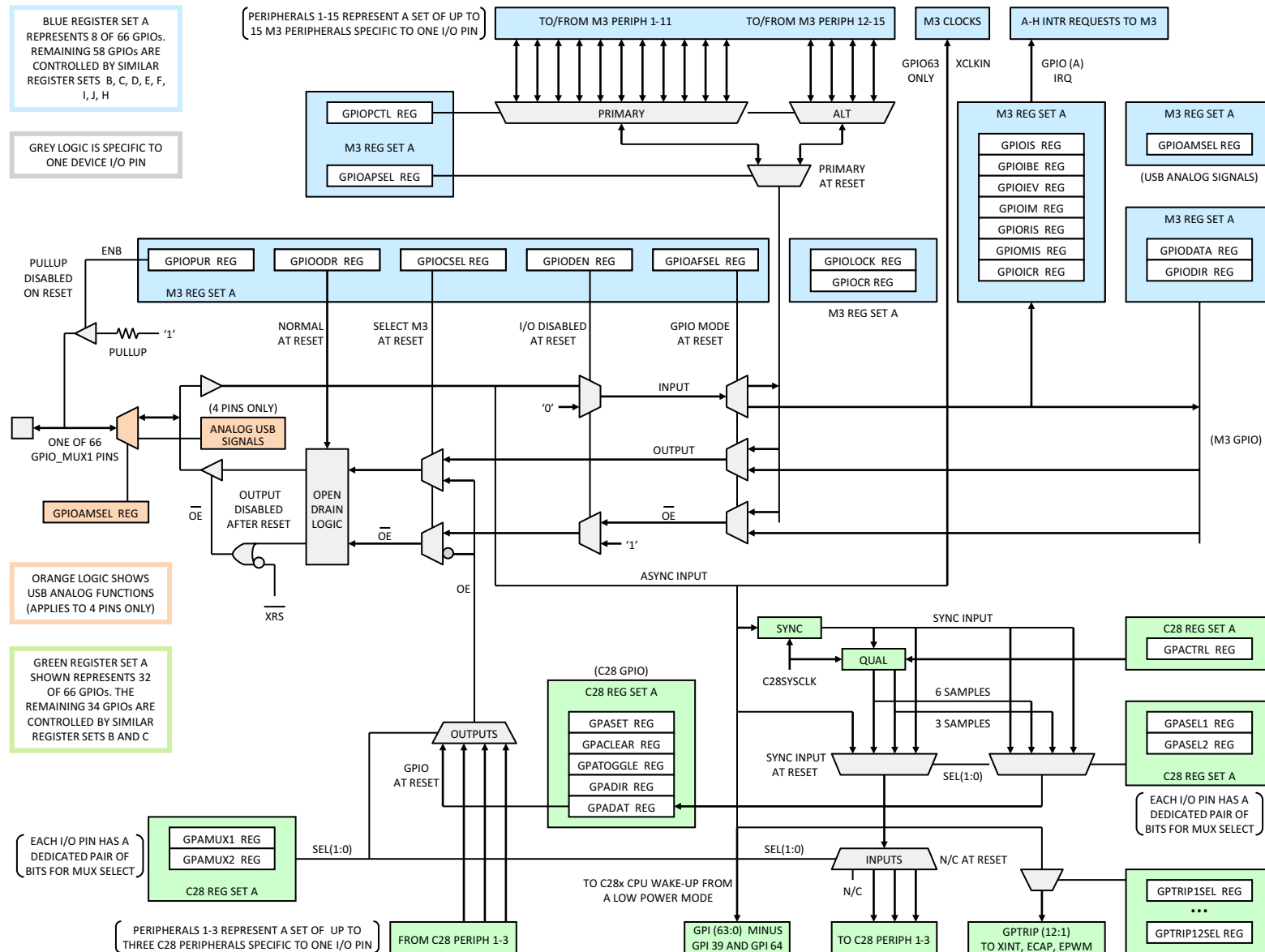

Figure 6-16. GPIO\_MUX1 Pin Mapping Through Register Set A

For each of the 8 pins in set A of the Cortex-M3 GPIO registers, register GPIOCTL selects between 1 of 11 possible primary Cortex-M3 peripheral signals, or 1 of 4 possible alternate peripheral signals. Register GPIOAPSEL then picks one output to propagate further along the muxing chain towards a given pin. The input takes the reverse path. See [Table 6-27](#) and [Table 6-28](#) for the mapping of Cortex-M3 peripheral signals to GPIO\_MUX1 pins.

Similarly, on the C28x side, GPAMUX1 and GPAMUX2 registers select 1 of 4 possible C28x peripheral signals for each of 32 pins of set A. The selected C28x peripheral output then propagates further along the muxing chain towards a given pin. The input takes the reverse path. See [Table 6-29](#) for the mapping of C28x peripheral signals to GPIO\_MUX1 pins.

In addition to passing mostly digital signals, four GPIO\_MUX1 pins can also be assigned to analog signals. The GPIO Analog Mode Select (GPIOAMSEL) Register is used to assign four pins to analog USB signals. PF6\_GPIO38 becomes USB0VBUS, PG2\_GPIO42 becomes USB0DM, PG5\_GPIO45 becomes USB0DP, and PG6\_GPIO46 becomes USB0ID. When analog mode is selected, these four pins are not available for digital GPIO\_MUX1 options as described above.

Another special case is the External Oscillator Input signal (XCLKIN). This signal, available through pin PJ7\_GPIO63, is directly tied to USBPLLCLK (clock input to USB PLL) and two CAN modules. XCLKIN is always available at these modules where it can be selected through local registers.

---

#### NOTE

For GPIO\_MUX1 pins PF6\_GPIO38 and PG6\_GPIO46, only the corresponding USB function is available on silicon revision 0 devices (GPIO and other functions listed in [Table 4-1](#) are not available).

---

**Table 6-27. GPIO\_MUX1 Pin Assignments (M3 Primary Modes)<sup>(1)</sup>**

| ANALOG MODE (USB PINS) | DEVICE PIN NAME | M3 PRIMARY MODE 1 | M3 PRIMARY MODE 2 | M3 PRIMARY MODE 3 | M3 PRIMARY MODE 4 | M3 PRIMARY MODE 5 | M3 PRIMARY MODE 6 | M3 PRIMARY MODE 7 | M3 PRIMARY MODE 8      | M3 PRIMARY MODE 9 | M3 PRIMARY MODE 10 | M3 PRIMARY MODE 11 |
|------------------------|-----------------|-------------------|-------------------|-------------------|-------------------|-------------------|-------------------|-------------------|------------------------|-------------------|--------------------|--------------------|
| –                      | PA0_GPIO0       | U0RX              | –                 | –                 | –                 | –                 | –                 | –                 | I2C1SCL                | U1RX              | –                  | –                  |
| –                      | PA1_GPIO1       | U0TX              | –                 | –                 | –                 | –                 | –                 | –                 | I2C1SDA                | U1TX              | –                  | –                  |
| –                      | PA2_GPIO2       | SSI0CLK           | –                 | MIITXD2           | –                 | –                 | –                 | –                 | –                      | –                 | –                  | –                  |
| –                      | PA3_GPIO3       | SSI0FSS           | –                 | MIITXD1           | –                 | –                 | –                 | –                 | –                      | –                 | –                  | –                  |
| –                      | PA4_GPIO4       | SSI0RX            | –                 | MIITXD0           | –                 | CAN0RX            | –                 | –                 | –                      | –                 | –                  | –                  |
| –                      | PA5_GPIO5       | SSI0TX            | –                 | MIIRXDV           | –                 | CAN0TX            | –                 | –                 | –                      | –                 | –                  | –                  |
| –                      | PA6_GPIO6       | I2C1SCL           | CCP1              | MIIRXCK           | –                 | –                 | CAN0RX            | –                 | USB0EPEN               | –                 | –                  | –                  |
| –                      | PA7_GPIO7       | I2C1SDA           | CCP4              | MIIRXER           | –                 | –                 | CAN0TX            | CCP3              | USB0PFLT               | –                 | –                  | –                  |
| –                      | PB0_GPIO8       | CCP0              | –                 | –                 | –                 | U1RX              | –                 | –                 | –                      | –                 | –                  | –                  |
| –                      | PB1_GPIO9       | CCP2              | –                 | –                 | CCP1              | U1TX              | –                 | –                 | –                      | –                 | –                  | –                  |
| –                      | PB2_GPIO10      | I2C0SCL           | –                 | –                 | CCP3              | CCP0              | –                 | –                 | USB0EPEN               | –                 | –                  | –                  |
| –                      | PB3_GPIO11      | I2C0SDA           | –                 | –                 | –                 | –                 | –                 | –                 | USB0PFLT               | –                 | –                  | –                  |
| –                      | PB4_GPIO12      | –                 | –                 | –                 | U2RX              | CAN0RX            | –                 | U1RX              | EPI0S23                | –                 | –                  | –                  |
| –                      | PB5_GPIO13      | –                 | CCP5              | CCP6              | CCP0              | CAN0TX            | CCP2              | U1TX              | EPI0S22                | –                 | –                  | –                  |
| –                      | PB6_GPIO14      | CCP1              | CCP7              | –                 | –                 | –                 | CCP5              | –                 | EPI0S37 <sup>(2)</sup> | –                 | –                  | –                  |
| –                      | PB7_GPIO15      | –                 | –                 | –                 | EXTNMI            | –                 | –                 | MIIRXD1           | EPI0S36 <sup>(2)</sup> | –                 | –                  | –                  |
| –                      | PD0_GPIO16      | –                 | CAN0RX            | –                 | U2RX              | U1RX              | CCP6              | MIIRXDV           | –                      | –                 | –                  | –                  |
| –                      | PD1_GPIO17      | –                 | CAN0TX            | –                 | U2TX              | U1TX              | CCP7              | MIITXER           | –                      | –                 | CCP2               | –                  |
| –                      | PD2_GPIO18      | U1RX              | CCP6              | –                 | CCP5              | –                 | –                 | –                 | EPI0S20                | –                 | –                  | –                  |
| –                      | PD3_GPIO19      | U1TX              | CCP7              | –                 | CCP0              | –                 | –                 | –                 | EPI0S21                | –                 | –                  | –                  |
| –                      | PD4_GPIO20      | CCP0              | CCP3              | –                 | MIITXD3           | –                 | –                 | –                 | –                      | –                 | EPI0S19            | –                  |
| –                      | PD5_GPIO21      | CCP2              | CCP4              | –                 | MIITXD2           | –                 | –                 | –                 | –                      | U2RX              | EPI0S28            | –                  |
| –                      | PD6_GPIO22      | –                 | –                 | –                 | MIITXD1           | –                 | –                 | –                 | –                      | U2TX              | EPI0S29            | –                  |
| –                      | PD7_GPIO23      | –                 | –                 | CCP1              | MIITXD0           | –                 | –                 | –                 | –                      | –                 | EPI0S30            | –                  |
| –                      | PE0_GPIO24      | –                 | SSI1CLK           | CCP3              | –                 | –                 | –                 | –                 | EPI0S8                 | USB0PFLT          | –                  | –                  |
| –                      | PE1_GPIO25      | –                 | SSI1FSS           | –                 | CCP2              | –                 | –                 | –                 | EPI0S9                 | –                 | –                  | –                  |
| –                      | PE2_GPIO26      | CCP4              | SSI1RX            | –                 | –                 | CCP6              | –                 | –                 | EPI0S24                | –                 | –                  | –                  |
| –                      | PE3_GPIO27      | CCP1              | SSI1TX            | –                 | –                 | CCP2              | –                 | –                 | EPI0S25                | –                 | –                  | –                  |
| –                      | PE4_GPIO28      | CCP3              | –                 | –                 | –                 | CCP7              | –                 | –                 | EPI0S26                | –                 | –                  | –                  |
| –                      | PE5_GPIO29      | CCP5              | –                 | –                 | –                 | U2TX              | CCP2              | MIIRXD0           | EPI0S34 <sup>(2)</sup> | –                 | –                  | –                  |
| –                      | PE6_GPIO30      | –                 | –                 | –                 | –                 | –                 | –                 | –                 | EPI0S35 <sup>(2)</sup> | –                 | –                  | –                  |
| –                      | PE7_GPIO31      | –                 | –                 | –                 | –                 | –                 | –                 | –                 | –                      | –                 | –                  | –                  |

(1) Blank fields represent Reserved functions.

(2) This muxing option is only available on silicon Revision A devices; this muxing option is not available on silicon Revision 0 devices.

Table 6-27. GPIO\_MUX1 Pin Assignments (M3 Primary Modes)<sup>(1)</sup> (continued)

| ANALOG MODE (USB PINS) | DEVICE PIN NAME     | M3 PRIMARY MODE 1 | M3 PRIMARY MODE 2 | M3 PRIMARY MODE 3 | M3 PRIMARY MODE 4 | M3 PRIMARY MODE 5 | M3 PRIMARY MODE 6 | M3 PRIMARY MODE 7 | M3 PRIMARY MODE 8      | M3 PRIMARY MODE 9 | M3 PRIMARY MODE 10 | M3 PRIMARY MODE 11 |
|------------------------|---------------------|-------------------|-------------------|-------------------|-------------------|-------------------|-------------------|-------------------|------------------------|-------------------|--------------------|--------------------|
| -                      | PF0_GPIO32          | CAN1RX            | -                 | -                 | MIIRXCK           | -                 | -                 | -                 | -                      | -                 | -                  | -                  |
| -                      | PF1_GPIO33          | CAN1TX            | -                 | -                 | MIIRXER           | -                 | -                 | -                 | -                      | -                 | CCP3               | -                  |
| -                      | PF2_GPIO34          | -                 | -                 | MIIPHYINTR        | -                 | -                 | -                 | -                 | EPI0S32 <sup>(2)</sup> | SSI1CLK           | -                  | -                  |
| -                      | PF3_GPIO35          | -                 | -                 | MIIMDC            | -                 | -                 | -                 | -                 | EPI0S33 <sup>(2)</sup> | SSI1FSS           | -                  | -                  |
| -                      | PF4_GPIO36          | CCP0              | -                 | MIIMDIO           | -                 | -                 | -                 | -                 | EPI0S12                | SSI1RX            | -                  | -                  |
| -                      | PF5_GPIO37          | CCP2              | -                 | MIIRXD3           | -                 | -                 | -                 | -                 | EPI0S15                | SSI1TX            | -                  | -                  |
| USB0VBUS               | PF6_GPIO38          | CCP1              | -                 | MIIRXD2           | -                 | -                 | -                 | -                 | EPI0S38 <sup>(2)</sup> | -                 | -                  | -                  |
| -                      | PF7_GPIO39 (no pin) | -                 | -                 | -                 | -                 | -                 | -                 | -                 | -                      | -                 | -                  | -                  |
| -                      | PG0_GPIO40          | U2RX              | -                 | I2C1SCL           | -                 | -                 | -                 | USB0EPEN          | EPI0S13                | -                 | -                  | -                  |
| -                      | PG1_GPIO41          | U2TX              | -                 | I2C1SDA           | -                 | -                 | -                 | -                 | EPI0S14                | -                 | -                  | -                  |
| USB0DM                 | PG2_GPIO42          | -                 | -                 | MIICOL            | -                 | -                 | -                 | -                 | EPI0S39 <sup>(2)</sup> | -                 | -                  | -                  |
| -                      | PG3_GPIO43          | -                 | -                 | MIICRS            | -                 | -                 | -                 | -                 | -                      | -                 | -                  | -                  |
| -                      | PG4_GPIO44 (no pin) | -                 | -                 | -                 | -                 | -                 | -                 | -                 | -                      | -                 | -                  | -                  |
| USB0DP                 | PG5_GPIO45          | CCP5              | -                 | MIITXEN           | -                 | -                 | -                 | -                 | EPI0S40 <sup>(2)</sup> | -                 | -                  | -                  |
| USB0ID                 | PG6_GPIO46          | -                 | -                 | MIITXCK           | -                 | -                 | -                 | -                 | EPI0S41 <sup>(2)</sup> | -                 | -                  | -                  |
| -                      | PG7_GPIO47          | -                 | -                 | MIITXER           | -                 | -                 | -                 | -                 | CCP5                   | EPI0S31           | -                  | -                  |
| -                      | PH0_GPIO48          | CCP6              | -                 | MIIPHYRST         | -                 | -                 | -                 | -                 | EPI0S6                 | -                 | -                  | -                  |
| -                      | PH1_GPIO49          | CCP7              | -                 | -                 | -                 | -                 | -                 | -                 | EPI0S7                 | -                 | -                  | -                  |
| -                      | PH2_GPIO50          | -                 | -                 | -                 | -                 | -                 | -                 | -                 | EPI0S1                 | MIITXD3           | -                  | -                  |
| -                      | PH3_GPIO51          | -                 | -                 | -                 | USB0EPEN          | -                 | -                 | -                 | EPI0S0                 | MIITXD2           | -                  | -                  |
| -                      | PH4_GPIO52          | -                 | -                 | -                 | USB0PFLT          | -                 | -                 | -                 | EPI0S10                | MIITXD1           | -                  | SSI1CLK            |
| -                      | PH5_GPIO53          | -                 | -                 | -                 | -                 | -                 | -                 | -                 | EPI0S11                | MIITXD0           | -                  | SSI1FSS            |
| -                      | PH6_GPIO54          | -                 | -                 | -                 | -                 | -                 | -                 | -                 | EPI0S26                | MIIRXDV           | -                  | SSI1RX             |
| -                      | PH7_GPIO55          | -                 | -                 | MIIRXCK           | -                 | -                 | -                 | -                 | EPI0S27                | -                 | -                  | SSI1TX             |
| -                      | PJ0_GPIO56          | -                 | -                 | MIIRXER           | -                 | -                 | -                 | -                 | EPI0S16                | -                 | -                  | I2C1SCL            |
| -                      | PJ1_GPIO57          | -                 | -                 | -                 | -                 | -                 | -                 | -                 | EPI0S17                | USB0PFLT          | -                  | I2C1SDA            |
| -                      | PJ2_GPIO58          | -                 | -                 | -                 | -                 | -                 | -                 | -                 | EPI0S18                | CCP0              | -                  | -                  |
| -                      | PJ3_GPIO59          | -                 | -                 | -                 | -                 | -                 | -                 | -                 | EPI0S19                | -                 | CCP6               | -                  |
| -                      | PJ4_GPIO60          | -                 | -                 | -                 | -                 | -                 | -                 | -                 | EPI0S28                | -                 | CCP4               | -                  |
| -                      | PJ5_GPIO61          | -                 | -                 | -                 | -                 | -                 | -                 | -                 | EPI0S29                | -                 | CCP2               | -                  |
| -                      | PJ6_GPIO62          | -                 | -                 | -                 | -                 | -                 | -                 | -                 | EPI0S30                | -                 | CCP1               | -                  |
| -                      | PJ7_GPIO63/XCLKIN   | -                 | -                 | -                 | -                 | -                 | -                 | -                 | -                      | -                 | CCP0               | -                  |

Table 6-27. GPIO\_MUX1 Pin Assignments (M3 Primary Modes)<sup>(1)</sup> (continued)

| ANALOG MODE (USB PINS) | DEVICE PIN NAME     | M3 PRIMARY MODE 1 | M3 PRIMARY MODE 2 | M3 PRIMARY MODE 3 | M3 PRIMARY MODE 4 | M3 PRIMARY MODE 5 | M3 PRIMARY MODE 6 | M3 PRIMARY MODE 7 | M3 PRIMARY MODE 8 | M3 PRIMARY MODE 9 | M3 PRIMARY MODE 10 | M3 PRIMARY MODE 11 |
|------------------------|---------------------|-------------------|-------------------|-------------------|-------------------|-------------------|-------------------|-------------------|-------------------|-------------------|--------------------|--------------------|
| –                      | PC0_GPIO64 (no pin) | –                 | –                 | –                 | –                 | –                 | –                 | –                 | –                 | –                 | –                  | –                  |
| –                      | PC1_GPIO65 (no pin) | –                 | –                 | –                 | –                 | –                 | –                 | –                 | –                 | –                 | –                  | –                  |
| –                      | PC2_GPIO66 (no pin) | –                 | –                 | –                 | –                 | –                 | –                 | –                 | –                 | –                 | –                  | –                  |
| –                      | PC3_GPIO67 (no pin) | –                 | –                 | –                 | –                 | –                 | –                 | –                 | –                 | –                 | –                  | –                  |
| –                      | PC4_GPIO68          | CCP5              | –                 | MIITXD3           | –                 | CCP2              | CCP4              | –                 | EPI0S2            | CCP1              | –                  | –                  |
| –                      | PC5_GPIO69          | CCP1              | –                 | –                 | –                 | CCP3              | USB0EPEN          | –                 | EPI0S3            | –                 | –                  | –                  |
| –                      | PC6_GPIO70          | CCP3              | –                 | –                 | –                 | U1RX              | CCP0              | USB0PFLT          | EPI0S4            | –                 | –                  | –                  |
| –                      | PC7_GPIO71          | CCP4              | –                 | –                 | CCP0              | U1TX              | USB0PFLT          | –                 | EPI0S5            | –                 | –                  | –                  |

**Table 6-28. GPIO\_MUX1 Pin Assignments (M3 Alternate Modes)<sup>(1)</sup>**

| ANALOG MODE<br>(USB PINS) | DEVICE PIN NAME        | M3<br>ALTERNATE<br>MODE 12 | M3<br>ALTERNATE<br>MODE 13 | M3<br>ALTERNATE<br>MODE 14 | M3<br>ALTERNATE<br>MODE 15 |
|---------------------------|------------------------|----------------------------|----------------------------|----------------------------|----------------------------|
| –                         | PA0_GPIO0              | –                          | –                          | –                          | –                          |
| –                         | PA1_GPIO1              | –                          | –                          | –                          | SSI1FSS                    |
| –                         | PA2_GPIO2              | –                          | –                          | –                          | –                          |
| –                         | PA3_GPIO3              | –                          | –                          | –                          | SSI1CLK                    |
| –                         | PA4_GPIO4              | –                          | –                          | –                          | –                          |
| –                         | PA5_GPIO5              | –                          | –                          | –                          | –                          |
| –                         | PA6_GPIO6              | MIITXD3                    | –                          | –                          | –                          |
| –                         | PA7_GPIO7              | MIIRXD1                    | –                          | –                          | –                          |
| –                         | PB0_GPIO8              | –                          | SSI2TX                     | CAN1TX                     | U4TX                       |
| –                         | PB1_GPIO9              | –                          | SSI2RX                     | –                          | –                          |
| –                         | PB2_GPIO10             | –                          | SSI2CLK                    | CAN1RX                     | U4RX                       |
| –                         | PB3_GPIO11             | –                          | SSI2FSS                    | U1RX                       | –                          |
| –                         | PB4_GPIO12             | –                          | –                          | CAN1TX                     | SSI1TX                     |
| –                         | PB5_GPIO13             | –                          | –                          | CAN1RX                     | SSI1RX                     |
| –                         | PB6_GPIO14             | MIICRS                     | I2C0SDA                    | U1TX                       | SSI1CLK                    |
| –                         | PB7_GPIO15             | –                          | I2C0SCL                    | U1RX                       | SSI1FSS                    |
| –                         | PD0_GPIO16             | MIIRXD2                    | SSI0TX                     | CAN1TX                     | USB0EPEN                   |
| –                         | PD1_GPIO17             | MIICOL                     | SSI0RX                     | CAN1RX                     | USB0PFLT                   |
| –                         | PD2_GPIO18             | –                          | SSI0CLK                    | U1TX                       | CAN0RX                     |
| –                         | PD3_GPIO19             | –                          | SSI0FSS                    | U1RX                       | CAN0TX                     |
| –                         | PD4_GPIO20             | –                          | –                          | U3TX                       | CAN1TX                     |
| –                         | PD5_GPIO21             | –                          | –                          | U3RX                       | CAN1RX                     |
| –                         | PD6_GPIO22             | –                          | –                          | I2C1SDA                    | U1TX                       |
| –                         | PD7_GPIO23             | –                          | –                          | I2C1SCL                    | U1RX                       |
| –                         | PE0_GPIO24             | –                          | SSI3TX                     | CAN0RX                     | SSI1TX                     |
| –                         | PE1_GPIO25             | –                          | SSI3RX                     | CAN0TX                     | SSI1RX                     |
| –                         | PE2_GPIO26             | –                          | SSI3CLK                    | U2RX                       | SSI1CLK                    |
| –                         | PE3_GPIO27             | –                          | SSI3FSS                    | U2TX                       | SSI1FSS                    |
| –                         | PE4_GPIO28             | –                          | U0RX                       | EPIOS38 <sup>(2)</sup>     | USB0EPEN                   |
| –                         | PE5_GPIO29             | MIITXER                    | U0TX                       | –                          | USB0PFLT                   |
| –                         | PE6_GPIO30             | MIIMDIO                    | CAN0RX                     | –                          | –                          |
| –                         | PE7_GPIO31             | MIIRXD3                    | CAN0TX                     | –                          | –                          |
| –                         | PF0_GPIO32             | –                          | I2C0SDA                    | TRACED2                    | –                          |
| –                         | PF1_GPIO33             | –                          | I2C0SCL                    | TRACED3                    | –                          |
| –                         | PF2_GPIO34             | –                          | –                          | TRACECLK                   | XCLKOUT                    |
| –                         | PF3_GPIO35             | –                          | U0TX                       | TRACED0                    | –                          |
| –                         | PF4_GPIO36             | –                          | U0RX                       | –                          | –                          |
| –                         | PF5_GPIO37             | –                          | –                          | –                          | –                          |
| USB0VBUS                  | PF6_GPIO38             | –                          | –                          | –                          | –                          |
| –                         | PF7_GPIO39<br>(no pin) | –                          | –                          | –                          | –                          |

(1) Blank fields represent Reserved functions.

(2) This muxing option is only available on silicon Revision A devices; this muxing option is not available on silicon Revision 0 devices.

Table 6-28. GPIO\_MUX1 Pin Assignments (M3 Alternate Modes)<sup>(1)</sup> (continued)

| ANALOG MODE (USB PINS) | DEVICE PIN NAME       | M3 ALTERNATE MODE 12           | M3 ALTERNATE MODE 13 | M3 ALTERNATE MODE 14 | M3 ALTERNATE MODE 15 |
|------------------------|-----------------------|--------------------------------|----------------------|----------------------|----------------------|
| –                      | PG0_GPIO40            | MIIRXD2                        | U4RX                 | –                    | –                    |
| –                      | PG1_GPIO41            | MIIRXD1                        | U4TX                 | –                    | –                    |
| USB0DM                 | PG2_GPIO42            | –                              | –                    | –                    | –                    |
| –                      | PG3_GPIO43            | MIIRXDV                        | –                    | TRACED1              | –                    |
| –                      | PG4_GPIO44 (no pin)   | –                              | –                    | –                    | –                    |
| USB0DP                 | PG5_GPIO45            | –                              | –                    | –                    | –                    |
| USB0ID                 | PG6_GPIO46            | –                              | –                    | –                    | –                    |
| –                      | PG7_GPIO47            | –                              | –                    | –                    | –                    |
| –                      | PH0_GPIO48            | –                              | SSI3TX               | –                    | –                    |
| –                      | PH1_GPIO49            | MIIRXD0                        | SSI3RX               | –                    | –                    |
| –                      | PH2_GPIO50            | –                              | SSI3CLK              | –                    | –                    |
| –                      | PH3_GPIO51            | –                              | SSI3FSS              | –                    | –                    |
| –                      | PH4_GPIO52            | –                              | U3TX                 | –                    | –                    |
| –                      | PH5_GPIO53            | –                              | U3RX                 | –                    | –                    |
| –                      | PH6_GPIO54            | MIITXEN                        | SSI0TX               | –                    | –                    |
| –                      | PH7_GPIO55            | MIITXCK                        | SSI0RX               | –                    | –                    |
| –                      | PJ0_GPIO56            | –                              | SSI0CLK              | –                    | –                    |
| –                      | PJ1_GPIO57            | MIIRXDV                        | SSI0FSS              | –                    | –                    |
| –                      | PJ2_GPIO58            | MIIRXCK                        | SSI0CLK              | U0TX                 | –                    |
| –                      | PJ3_GPIO59            | MIIMDC                         | SSI0FSS              | U0RX                 | –                    |
| –                      | PJ4_GPIO60            | MIICOL                         | SSI1CLK              | –                    | –                    |
| –                      | PJ5_GPIO61            | MIICRS                         | SSI1FSS              | –                    | –                    |
| –                      | PJ6_GPIO62            | $\overline{\text{MIIPHYINTR}}$ | U2RX                 | –                    | –                    |
| –                      | PJ7_GPIO63/<br>XCLKIN | $\overline{\text{MIIPHYRST}}$  | U2TX                 | –                    | –                    |
| –                      | PC0_GPIO64 (no pin)   | –                              | –                    | –                    | –                    |
| –                      | PC1_GPIO65 (no pin)   | –                              | –                    | –                    | –                    |
| –                      | PC2_GPIO66 (no pin)   | –                              | –                    | –                    | –                    |
| –                      | PC3_GPIO67 (no pin)   | –                              | –                    | –                    | –                    |
| –                      | PC4_GPIO68            | –                              | –                    | –                    | –                    |
| –                      | PC5_GPIO69            | –                              | –                    | –                    | –                    |
| –                      | PC6_GPIO70            | –                              | –                    | –                    | –                    |
| –                      | PC7_GPIO71            | –                              | –                    | –                    | –                    |

**Table 6-29. GPIO\_MUX1 Pin Assignments (C28x Peripheral Modes)<sup>(1)</sup>**

| ANALOG MODE<br>(USB PINS) | DEVICE PIN NAME        | C28x<br>PERIPHERAL<br>MODE 0 | C28x<br>PERIPHERAL<br>MODE 1 | C28x<br>PERIPHERAL<br>MODE 2 | C28x<br>PERIPHERAL<br>MODE 3 |
|---------------------------|------------------------|------------------------------|------------------------------|------------------------------|------------------------------|
| –                         | PA0_GPIO0              | GPIO0                        | EPWM1A                       | –                            | –                            |
| –                         | PA1_GPIO1              | GPIO1                        | EPWM1B                       | ECAP6                        | –                            |
| –                         | PA2_GPIO2              | GPIO2                        | EPWM2A                       | –                            | –                            |
| –                         | PA3_GPIO3              | GPIO3                        | EPWM2B                       | ECAP5                        | –                            |
| –                         | PA4_GPIO4              | GPIO4                        | EPWM3A                       | –                            | –                            |
| –                         | PA5_GPIO5              | GPIO5                        | EPWM3B                       | MFSRA                        | ECAP1                        |
| –                         | PA6_GPIO6              | GPIO6                        | EPWM4A                       | –                            | EPWMSYNCO                    |
| –                         | PA7_GPIO7              | GPIO7                        | EPWM4B                       | MCLKRA                       | ECAP2                        |
| –                         | PB0_GPIO8              | GPIO8                        | EPWM5A                       | –                            | ADCSOAO                      |
| –                         | PB1_GPIO9              | GPIO9                        | EPWM5B                       | –                            | ECAP3                        |
| –                         | PB2_GPIO10             | GPIO10                       | EPWM6A                       | –                            | ADCSOAO                      |
| –                         | PB3_GPIO11             | GPIO11                       | EPWM6B                       | –                            | ECAP4                        |
| –                         | PB4_GPIO12             | GPIO12                       | EPWM7A                       | –                            | –                            |
| –                         | PB5_GPIO13             | GPIO13                       | EPWM7B                       | –                            | –                            |
| –                         | PB6_GPIO14             | GPIO14                       | EPWM8A                       | –                            | –                            |
| –                         | PB7_GPIO15             | GPIO15                       | EPWM8B                       | –                            | –                            |
| –                         | PD0_GPIO16             | GPIO16                       | SPISIMOA                     | –                            | –                            |
| –                         | PD1_GPIO17             | GPIO17                       | SPISOMIA                     | –                            | –                            |
| –                         | PD2_GPIO18             | GPIO18                       | SPICLKA                      | –                            | –                            |
| –                         | PD3_GPIO19             | GPIO19                       | SPISTEA                      | –                            | –                            |
| –                         | PD4_GPIO20             | GPIO20                       | EQEP1A                       | MDXA                         | –                            |
| –                         | PD5_GPIO21             | GPIO21                       | EQEP1B                       | MDRA                         | –                            |
| –                         | PD6_GPIO22             | GPIO22                       | EQEP1S                       | MCLKXA                       | –                            |
| –                         | PD7_GPIO23             | GPIO23                       | EQEP1I                       | MFSXA                        | –                            |
| –                         | PE0_GPIO24             | GPIO24                       | ECAP1                        | EQEP2A                       | –                            |
| –                         | PE1_GPIO25             | GPIO25                       | ECAP2                        | EQEP2B                       | –                            |
| –                         | PE2_GPIO26             | GPIO26                       | ECAP3                        | EQEP2I                       | –                            |
| –                         | PE3_GPIO27             | GPIO27                       | ECAP4                        | EQEP2S                       | –                            |
| –                         | PE4_GPIO28             | GPIO28                       | SCIRXDA                      | –                            | –                            |
| –                         | PE5_GPIO29             | GPIO29                       | SCITXDA                      | –                            | –                            |
| –                         | PE6_GPIO30             | GPIO30                       | –                            | –                            | EPWM9A                       |
| –                         | PE7_GPIO31             | GPIO31                       | –                            | –                            | EPWM9B                       |
| –                         | PF0_GPIO32             | GPIO32                       | I2CASDA                      | SCIRXDA                      | ADCSOAO                      |
| –                         | PF1_GPIO33             | GPIO33                       | I2CASCL                      | EPWMSYNCO                    | ADCSOAO                      |
| –                         | PF2_GPIO34             | GPIO34                       | ECAP1                        | SCIRXDA                      | XCLKOUT                      |
| –                         | PF3_GPIO35             | GPIO35                       | SCITXDA                      | –                            | –                            |
| –                         | PF4_GPIO36             | GPIO36                       | SCIRXDA                      | –                            | –                            |
| –                         | PF5_GPIO37             | GPIO37                       | ECAP2                        | –                            | –                            |
| USB0VBUS                  | PF6_GPIO38             | GPIO38                       | –                            | –                            | –                            |
| –                         | PF7_GPIO39<br>(no pin) | –                            | –                            | –                            | –                            |

(1) Blank fields represent Reserved functions.

**Table 6-29. GPIO\_MUX1 Pin Assignments (C28x Peripheral Modes)<sup>(1)</sup> (continued)**

| ANALOG MODE (USB PINS) | DEVICE PIN NAME       | C28x PERIPHERAL MODE 0 | C28x PERIPHERAL MODE 1 | C28x PERIPHERAL MODE 2 | C28x PERIPHERAL MODE 3 |
|------------------------|-----------------------|------------------------|------------------------|------------------------|------------------------|
| –                      | PG0_GPIO40            | GPIO40                 | –                      | –                      | –                      |
| –                      | PG1_GPIO41            | GPIO41                 | –                      | –                      | –                      |
| USB0DM                 | PG2_GPIO42            | GPIO42                 | –                      | –                      | –                      |
| –                      | PG3_GPIO43            | GPIO43                 | –                      | –                      | –                      |
| –                      | PG4_GPIO44 (no pin)   | –                      | –                      | –                      | –                      |
| USB0DP                 | PG5_GPIO45            | GPIO45                 | –                      | –                      | –                      |
| USB0ID                 | PG6_GPIO46            | GPIO46                 | –                      | –                      | –                      |
| –                      | PG7_GPIO47            | GPIO47                 | –                      | –                      | –                      |
| –                      | PH0_GPIO48            | GPIO48                 | ECAP5                  | –                      | –                      |
| –                      | PH1_GPIO49            | GPIO49                 | ECAP6                  | –                      | –                      |
| –                      | PH2_GPIO50            | GPIO50                 | EQEP1A                 | –                      | –                      |
| –                      | PH3_GPIO51            | GPIO51                 | EQEP1B                 | –                      | –                      |
| –                      | PH4_GPIO52            | GPIO52                 | EQEP1S                 | –                      | –                      |
| –                      | PH5_GPIO53            | GPIO53                 | EQEP1I                 | –                      | –                      |
| –                      | PH6_GPIO54            | GPIO54                 | SPISIMOA               | –                      | EQEP3A                 |
| –                      | PH7_GPIO55            | GPIO55                 | SPISOMIA               | –                      | EQEP3B                 |
| –                      | PJ0_GPIO56            | GPIO56                 | SPICLKA                | –                      | EQEP3S                 |
| –                      | PJ1_GPIO57            | GPIO57                 | SPISTEA                | –                      | EQEP3I                 |
| –                      | PJ2_GPIO58            | GPIO58                 | MCLKRA                 | –                      | EPWM7A                 |
| –                      | PJ3_GPIO59            | GPIO59                 | MFSRA                  | –                      | EPWM7B                 |
| –                      | PJ4_GPIO60            | GPIO60                 | –                      | –                      | EPWM8A                 |
| –                      | PJ5_GPIO61            | GPIO61                 | –                      | –                      | EPWM8B                 |
| –                      | PJ6_GPIO62            | GPIO62                 | –                      | –                      | EPWM9A                 |
| –                      | PJ7_GPIO63/<br>XCLKIN | GPIO63                 | –                      | –                      | EPWM9B                 |
| –                      | PC0_GPIO64 (no pin)   | –                      | –                      | –                      | –                      |
| –                      | PC1_GPIO65 (no pin)   | –                      | –                      | –                      | –                      |
| –                      | PC2_GPIO66 (no pin)   | –                      | –                      | –                      | –                      |
| –                      | PC3_GPIO67 (no pin)   | –                      | –                      | –                      | –                      |
| –                      | PC4_GPIO68            | GPIO68                 | –                      | –                      | –                      |
| –                      | PC5_GPIO69            | GPIO69                 | –                      | –                      | –                      |
| –                      | PC6_GPIO70            | GPIO70                 | –                      | –                      | –                      |
| –                      | PC7_GPIO71            | GPIO71                 | –                      | –                      | –                      |

### 6.16.2 GPIO\_MUX2

The eight pins of the GPIO\_MUX2 block can be selectively mapped to eight General-Purpose Inputs, eight General-Purpose Outputs, or six COMPOUT outputs from the Analog Comparator peripheral. Each GPIO\_MUX2 pin can have a pullup enabled or disabled. On reset, all pins of the GPIO\_MUX2 block are configured as analog inputs, and the GPIO function is disabled. The GPIO\_MUX2 block is programmed through a separate set of registers from those used to program GPIO\_MUX1.

The multiple registers responsible for configuring the GPIO\_MUX2 pins are organized in register set E. They are accessible by the C28x CPU only. The middle portion of [Figure 6-17](#) shows set G of Control Subsystem registers, plus muxing logic for the associated eight GPIO pins. The GPEMUX1 register selects one of six possible digital output signals from analog comparators, or one of eight general-purpose GPIO digital outputs. The GPEPUD register disables pullups for the GPIO\_MUX2 pins when a corresponding bit of that register is set to “1”. Other registers of set G allow reading and writing of the eight GPIO bits, as well as setting the direction for each of the bits (read or write). See [Table 6-30](#) for the mapping of comparator outputs and GPIO to the eight pins of GPIO\_MUX2.

Peripheral Modes 0, 1, 2, and 3 are chosen by setting selected bit pairs of GPEMUX1 register to “00”, “01”, “10”, and “11”, respectively. For example, setting bits 5–4 of the GPEMUX1 register to “00” (Peripheral Mode 0) assigns pin GPIO130 to internal signal GPIO130 (digital GPIO). Setting bits 5–4 of the GPEMUX1 register to “11” (Peripheral Mode 3) assigns pin GPIO130 to internal signal COMP6OUT coming from Analog Comparator 6. Peripheral Modes 1 and 2 are reserved and are not currently available.

**Table 6-30. GPIO\_MUX2 Pin Assignments (C28x Peripheral Modes)<sup>(1)</sup>**

| DEVICE PIN NAME | C28x PERIPHERAL MODE 0 | C28x PERIPHERAL MODE 1 | C28x PERIPHERAL MODE 2 | C28x PERIPHERAL MODE 3 |
|-----------------|------------------------|------------------------|------------------------|------------------------|
| GPIO128         | GPIO128                | –                      | –                      | –                      |
| GPIO129         | GPIO129                | –                      | –                      | COMP1OUT               |
| GPIO130         | GPIO130                | –                      | –                      | COMP6OUT               |
| GPIO131         | GPIO131                | –                      | –                      | COMP2OUT               |
| GPIO132         | GPIO132                | –                      | –                      | COMP3OUT               |
| GPIO133         | GPIO133                | –                      | –                      | COMP4OUT               |
| GPIO134         | GPIO134                | –                      | –                      | –                      |
| GPIO135         | GPIO135                | –                      | –                      | COMP5OUT               |

(1) Blank fields represent Reserved functions.

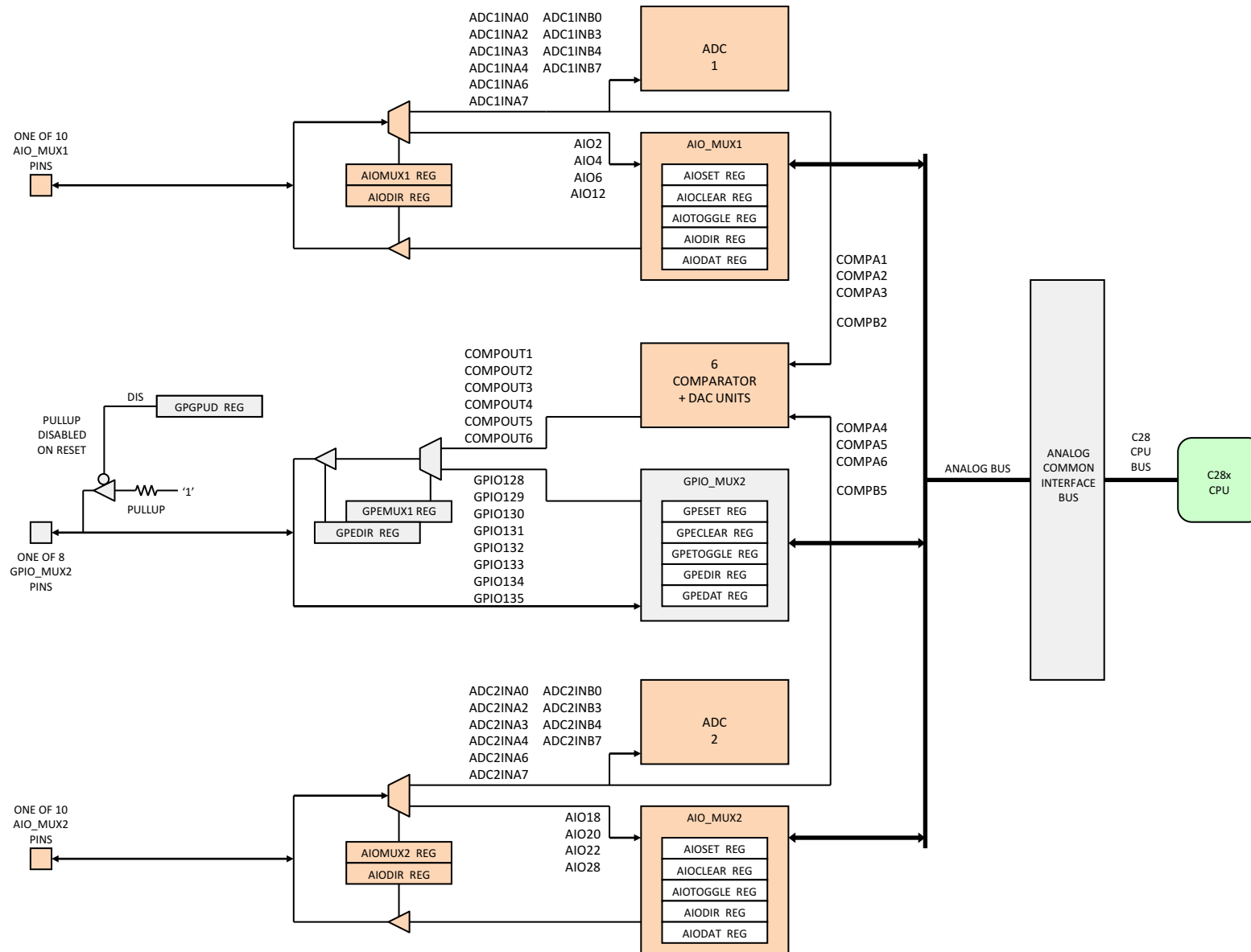

Figure 6-17. Pin Muxing on AIO\_MUX1, AIO\_MUX2, and GPIO\_MUX2

### 6.16.3 AIO\_MUX1

The ten pins of AIO\_MUX1 can be selectively mapped through a dedicated set of registers to 12 analog inputs for ADC1 peripheral, six analog inputs for Comparator peripherals, four General-Purpose Inputs, or four General-Purpose Outputs. While AIO\_MUX1 has been named after the analog signals passing through it, the GPIOs (here called AIOs) are still digital, although with fewer features than those in the GPIO\_MUX1 and GPIO\_MUX2 blocks—for example, they do not offer pullups. On reset, all pins of the AIO\_MUX1 block are configured as analog inputs and the GPIO function is disabled. The AIO\_MUX1 block is programmed through a separate set of registers from those used to program AIO\_MUX2.

The multiple registers responsible for configuring the AIO\_MUX1 pins are accessible by the C28x CPU only. The top portion of [Figure 6-17](#) shows Control Subsystem registers and muxing logic for the associated ten AIO pins. The AIOMUX1 register selects one of ten possible analog input signals or one of four general-purpose AIO inputs. Other registers allow reading and writing of the four AIO bits, as well as setting the direction for each of the bits (read or write). See [Table 6-31](#) for the mapping of analog inputs and AIOs to the ten pins of AIO\_MUX1.

AIO Mode 0 is chosen by setting selected odd bits of the AIOMUX1 register to '0'. AIO Mode 1 is chosen by setting selected odd bits of the AIOMUX1 register to '1'. For example, setting bit 5 of the AIOMUX1 register to '0' assigns pin ADC1INA2 to internal signal AIO2 (digital GPIO). Setting bit 5 of the AIOMUX1 register to '1' assigns pin ADC1INA2 to analog inputs ADC1INA2 or COMPA1 (only one should be enabled at a time in the respective analog module). Currently, all even bits of the AIOMUX1 register are "don't cares".

**Table 6-31. AIO\_MUX1 Pin Assignments (C28x AIO Modes)<sup>(1)(2)</sup>**

| DEVICE PIN NAME | C28x AIO MODE 0 <sup>(3)</sup> | C28x AIO MODE 1 <sup>(4)</sup> |
|-----------------|--------------------------------|--------------------------------|
| ADC1INA0        | –                              | ADC1INA0                       |
| ADC1INA2        | AIO2                           | ADC1INA2, COMPA1               |
| ADC1INA3        | –                              | ADC1INA3                       |
| ADC1INA4        | AIO4                           | ADC1INA4, COMPA2               |
| ADC1INA6        | AIO6                           | ADC1INA6, COMPA3               |
| ADC1INA7        | –                              | ADC1INA7                       |
| ADC1INB0        | –                              | ADC1INB0                       |
| ADC1INB3        | –                              | ADC1INB3                       |
| ADC1INB4        | AIO12                          | ADC1INB4, COMPB2               |
| ADC1INB7        | –                              | ADC1INB7                       |

(1) Blank fields represent Reserved functions.

(2) For each field with two pins (for example, ADC1INA2, COMPA1), only one pin should be enabled at a time; the other pin should be disabled. Use registers inside the respective destination analog peripherals to enable or disable these inputs.

(3) AIO Mode 0 represents digital general-purpose inputs or outputs.

(4) AIO Mode 1 represents analog inputs for ADC1 or the Comparator module.

### 6.16.4 AIO\_MUX2

The ten pins of AIO\_MUX2 can be selectively mapped through a dedicated set of registers to 12 analog inputs for ADC2 peripheral, six analog inputs for Comparator peripherals, four General-Purpose Inputs, or four General-Purpose Outputs. While AIO\_MUX2 has been named after the analog signals passing through it, the GPIOs (here called AIOs) are still digital, although with fewer features than those in the GPIO\_MUX1 and GPIO\_MUX2 blocks—for example, they do not offer pullups. On reset, all pins of the AIO\_MUX2 block are configured as analog inputs and the GPIO function is disabled. The AIO\_MUX2 block is programmed through a separate set of registers from those used to program AIO\_MUX1.

The multiple registers responsible for configuring the AIO\_MUX2 pins are accessible by the C28x CPU only. The bottom portion of [Figure 6-17](#) shows Control Subsystem registers and muxing logic for the associated ten AIO pins. The AIOMUX2 register selects one of ten possible analog input signals or one of four general-purpose AIO inputs. Other registers allow reading and writing of the four AIO bits, as well as setting the direction for each of the bits (read or write). See [Table 6-32](#) for the mapping of analog inputs and AIOs to the ten pins of AIO\_MUX2. Peripheral Modes 1 and 2 are currently not available.

AIO Mode 0 is chosen by setting selected odd bits of the AIOMUX2 register to '0'. AIO Mode 1 is chosen by setting selected odd bits of the AIOMUX2 register to '1'. For example, setting bit 9 of the AIOMUX2 register to '0' assigns pin ADC2INA4 to internal signal AIO20 (digital GPIO). Setting bit 9 of the AIOMUX2 register to '1' assigns pin ADC2INA4 to analog inputs ADC2INA4 or COMPA5 (only one should be enabled at a time in the respective analog module). Currently, all even bits of the AIOMUX2 register are “don't cares”.

**Table 6-32. AIO\_MUX2 Pin Assignments (C28x AIO Modes)<sup>(1)(2)</sup>**

| DEVICE PIN NAME | C28x AIO MODE 0 <sup>(3)</sup> | C28x AIO MODE 1 <sup>(4)</sup> |
|-----------------|--------------------------------|--------------------------------|
| ADC2INA0        | –                              | ADC2INA0                       |
| ADC2INA2        | AIO18                          | ADC2INA2, COMPA4               |
| ADC2INA3        | –                              | ADC2INA3                       |
| ADC2INA4        | AIO20                          | ADC2INA4, COMPA5               |
| ADC2INA6        | AIO22                          | ADC2INA6, COMPA6               |
| ADC2INA7        | –                              | ADC2INA7                       |
| ADC2INB0        | –                              | ADC2INB0                       |
| ADC2INB3        | –                              | ADC2INB3                       |
| ADC2INB4        | AIO28                          | ADC2INB4, COMPB5               |
| ADC2INB7        | –                              | ADC2INB7                       |

(1) Blank fields represent Reserved functions.

(2) For each field with two pins (for example, ADC2INA6, COMPA6), only one pin should be enabled at a time; the other pin should be disabled. Use registers inside the respective destination analog peripherals to enable or disable these inputs.

(3) AIO Mode 0 represents digital general-purpose inputs or outputs.

(4) AIO Mode 1 represents analog inputs for ADC2 or the Comparator module.

## 6.17 Emulation/JTAG

Concerto devices have two types of emulation ports to support debug operations: the 7-pin TI JTAG port and the 5-pin Cortex-M3 Instrumentation Trace Macrocell (ITM) port. The 7-pin TI JTAG port can be used to connect to debug tools through the TI 14-pin JTAG header or the TI 20-pin JTAG header. The 5-pin Cortex-M3 ITM port can only be accessed through the TI 20-pin JTAG header.

The JTAG port has seven dedicated pins:  $\overline{\text{TRST}}$ , TMS, TDI, TDO, TCK, EMU0, and EMU1. The  $\overline{\text{TRST}}$  signal should always be pulled down through a 2.2-k $\Omega$  pulldown resistor on the board. EMU0 and EMU1 signals should be pulled up through a pair of pullups ranging from 2.2 k $\Omega$  to 4.7 k $\Omega$  (depending on the drive strength of the debugger ports). The JTAG port is TI's standard debug port.

The ITM port uses five GPIO pins that can be mapped to internal Cortex-M3 ITM trace signals: TRACE0, TRACE1, TRACE2, TRACE3, and TRACECLK. This port is typically used for advanced software debug.

TI emulators, and those from other manufacturers, can connect to Concerto devices through TI's 14-pin JTAG header or 20-pin JTAG header. See [Figure 6-18](#) to see how the 14-pin JTAG header connects to the JTAG port signals in Concerto. The 14-pin header does not support the ITM debug mode.

[Figure 6-19](#) shows two possible ways to connect the 20-pin header to the emulation pins in Concerto. The left side of the drawing shows all seven JTAG signals connecting to the 20-pin header similar to the way the 14-pin header was connected. The JTAG EMU0 and EMU1 signals are mapped to the corresponding terminals on the 20-pin header. In this mode, header terminals EMU2, EMU3, and EMU4 are left unconnected and the ITM trace mode is not available.

The right side of the drawing shows the same 20-pin header now connected to five ITM signals and five of seven JTAG signals. The EMU0 and EMU1 signals in Concerto are left unconnected in this mode; thus, the emulation functions associated with these two signals are not available when debugging with ITM trace.

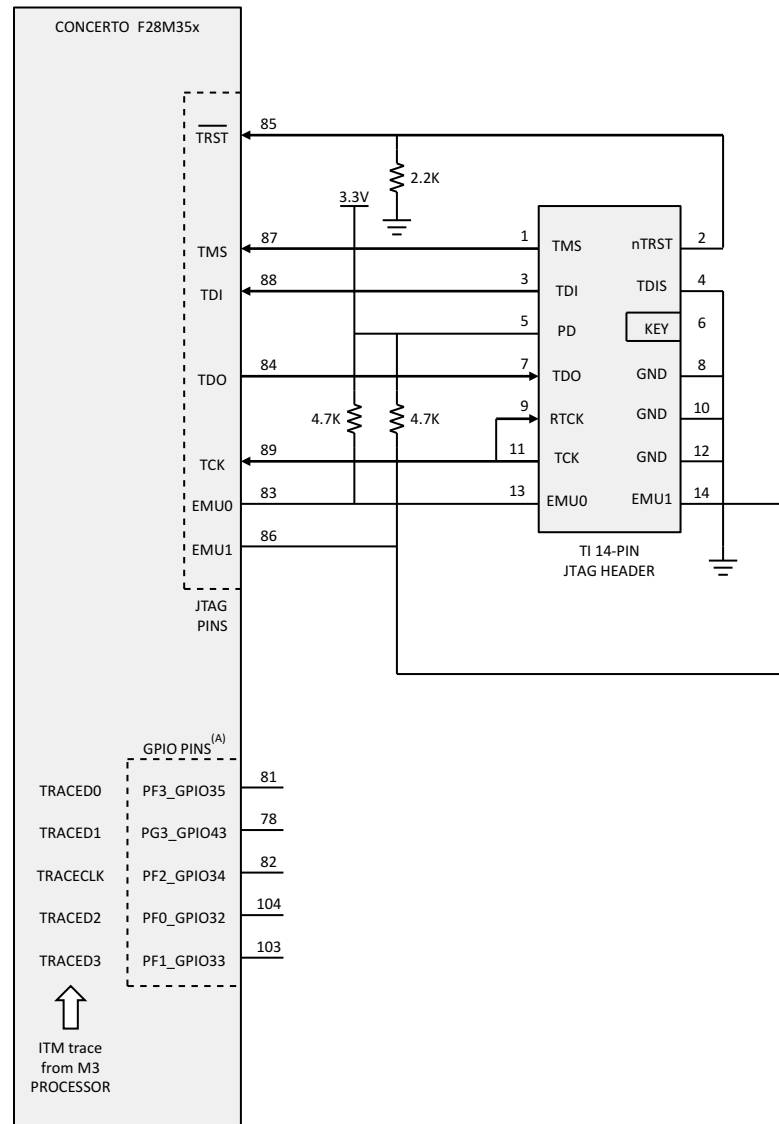

A. The GPIO pins (GPIO32–GPIO35 and GPIO43) may be used in the application if ITM trace is not used.

**Figure 6-18. Connecting to TI 14-Pin JTAG Emulator Header**

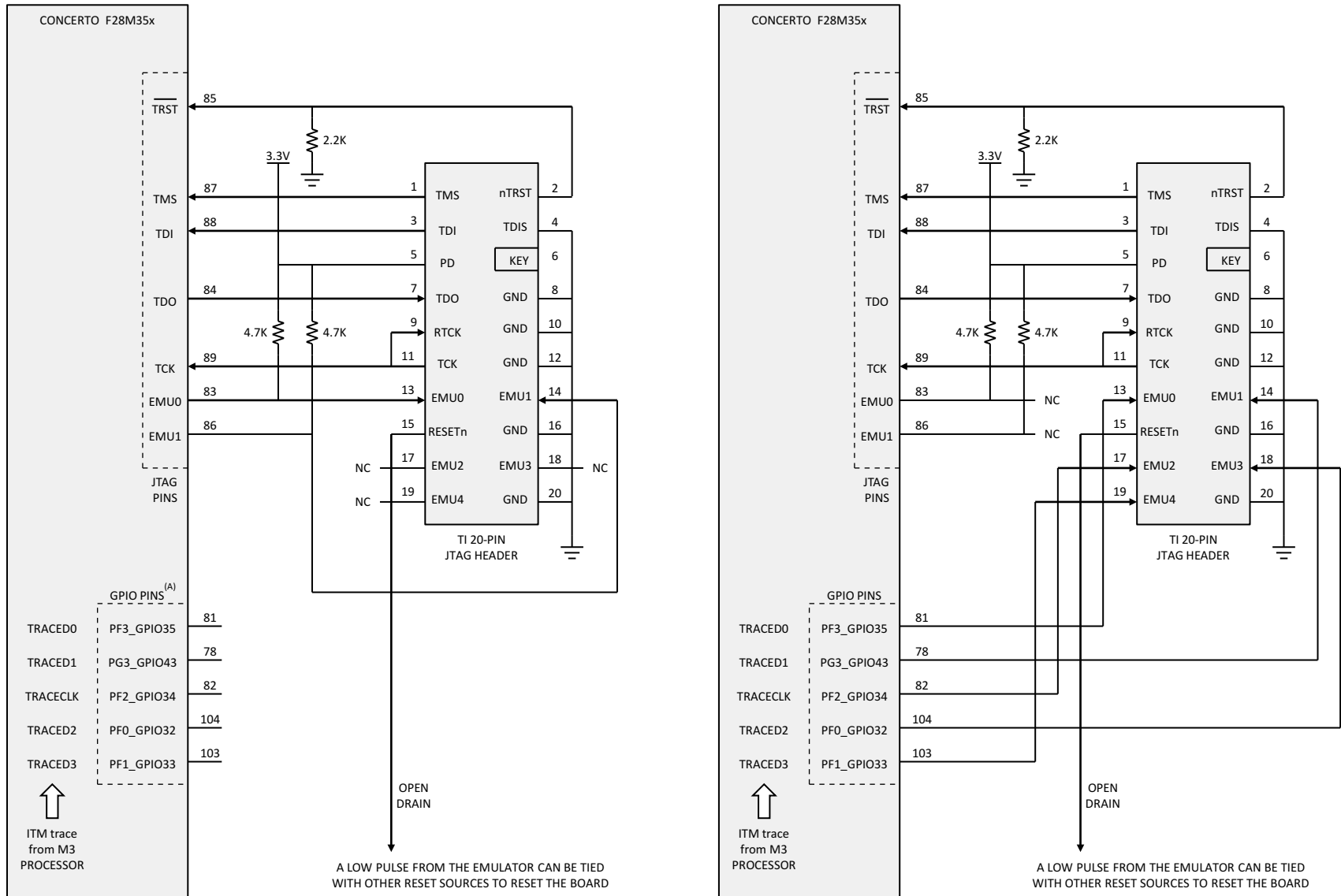

A. The GPIO pins (GPIO32–GPIO35 and GPIO43) may be used in the application if ITM trace is not used.

Figure 6-19. Connecting to TI 20-Pin JTAG Emulator Header

## 6.18 Code Security Module

The Code Security Module (CSM) is a security feature incorporated in Concerto devices. The CSM prevents access and visibility to on-chip secure memories by unauthorized persons—that is, the CSM prevents duplication and reverse-engineering of proprietary code. The word "secure" means that access to on-chip secure memories is protected. The word "unsecure" means that access to on-chip secure memory is not protected—that is, the contents of the memory could be read by any means [for example, by using a debugging tool such as Code Composer Studio™ Integrated Development Environment (IDE)].

### 6.18.1 Functional Description

The security module restricts the CPU access to on-chip secure memory without interrupting or stalling CPU execution. When a read occurs to a protected memory location, the read returns a zero value and CPU execution continues with the next instruction. This process, in effect, blocks read and write access to various memories through the JTAG port or external peripherals. Security is defined with respect to the access of on-chip secure memories and prevents unauthorized copying of proprietary code or data.

The zone is secure when CPU access to the on-chip secure memories associated with that zone is restricted. When secure, two levels of protection are possible, depending on where the program counter is currently pointing. If code is currently running from inside secure memory, only an access through JTAG is blocked (that is, through the emulator). This process allows secure code to access secure data. Conversely, if code is running from unsecure memory, all accesses to secure memories are blocked. User code can dynamically jump in and out of secure memory, thereby allowing secure function calls from unsecure memory. Similarly, interrupt service routines can be placed in secure memory, even if the main program loop is run from unsecure memory.

The code security mechanism present in this device offers dual-zone security for the Cortex-M3 code and single-zone security for the C28x code. In case of dual-zone security on the master subsystem, the different secure memories (RAMs and flash sectors) can be assigned to different security zones by configuring the GRABRAM and GRABSECT registers associated with each zone. Flash Sector N and Flash Sector A are dedicated to Zone1 and Zone2, respectively, and cannot be allocated to any other zone by configuration. Similarly, flash sectors get assigned to different zones based on the setting in the GRABSECT registers.

Security is provided by a CSM password of 128 bits of data (four 32-bit words) that is used to secure or unsecure the zones. Each zone has its own 128-bit CSM password. The zone can be unsecured by executing the password match flow (PMF).

The CSM password for each zone is stored in its dedicated flash sector. The password storage locations in the flash sector store the CSM password. The password is selected by the system designer. If the password locations of a zone have all 128 bits as ones, the zone is considered "unsecure". Because new flash devices have erased flash (all ones), only a read of the password locations is required to bring any zone into unsecure mode. If the password locations of a zone have all 128 bits as zeros, the zone is considered "secure", regardless of the contents of the CSMKEY registers. The user should not use all zeros as a password or reset the device during an erase of the flash. Resetting the device during an erase routine can result in either an all-zero or unknown password. If a device is reset when the password locations are all zeros, the device cannot be unlocked by the password match flow. Using a password of all zeros will seriously limit the user's ability to debug secure code or reprogram the flash.

---

#### NOTE

If a device is reset while the password locations of a zone contain all zeros or an unknown value, that zone will be permanently locked unless a method to run the flash erase routine from secure SARAM is embedded into the flash or OTP. Care must be taken when implementing this procedure to avoid introducing a security hole.

---

## 6.19 $\mu$ CRC Module

The  $\mu$ CRC module is part of the master subsystem. This module can be used by Cortex-M3 software to compute CRC on data and program, which are stored at memory locations that are addressable by Cortex-M3. On this device, the Cortex-M3 Flash Bank and ROM are mapped to the code space that is only accessed by the ICODE/DCODE bus of Cortex-M3; and RAMs are mapped on the SRAM space that is accessible by the SYSTEM bus. Hence, the  $\mu$ CRC module snoops both the DCODE and SYSTEM buses to support CRC calculation for data and program.

### 6.19.1 Functional Description

The  $\mu$ CRC module snoops both the DCODE and SYSTEM buses to support CRC calculation for data and program. To allow interrupts execution in between CRC calculations for a block of data and to discard the Cortex-M3 literal pool accesses in between executions of the program (which reads data for CRC calculation), the Cortex-M3 ROM, Flash, and RAMs are mapped to a mirrored memory location. The  $\mu$ CRC module grabs data from the bus to calculate CRC only if the address of the read data belongs to mirrored memory space. After grabbing, the  $\mu$ CRC module performs the CRC calculation on the grabbed data and updates the  $\mu$ CRC Result Register ( $\mu$ CRCRES). This register can be read at any time to get the calculated CRC for all the previous read data. The  $\mu$ CRC module only supports CRC calculation for byte accesses. So, in order to calculate the CRC on a block of data, software must perform byte accesses to all the data. For half-word and word accesses, the  $\mu$ CRC module discards the data and does not update the  $\mu$ CRCRES register.

---

#### NOTE

If a read to a mirrored address space is thrown from the debugger (Code Composer Studio or any other debug platform), the  $\mu$ CRC module ignores the read data and does not update the CRC result for that particular read.

---

### 6.19.2 CRC Polynomials

The following are the CRC polynomials that are supported by the  $\mu$ CRC module:

- CRC8 Polynomial = 0x07
- CRC16 Polynomial-1 = 0x8005
- CRC16 Polynomial-2 = 0x1021
- CRC32 Polynomial = 0x04C11DB7

### 6.19.3 CRC Calculation Procedure

The software procedure for calculating CRC for a set of data that is stored in Cortex-M3 addressable memory space is as follows:

1. Save the current value of the  $\mu$ CRC Result Register ( $\mu$ CRCRES) into the stack to allow calculation of CRC in nested interrupt
2. Clear the  $\mu$ CRC Result Register ( $\mu$ CRCRES) by setting the CLEAR field of the  $\mu$ CRC Control Register ( $\mu$ CRCCONTROL) to "1"
3. Configure the  $\mu$ CRC polynomials (CRC8, CRC16-P1, CRC16-P2, or CRC32) in the  $\mu$ CRC Configuration Register ( $\mu$ CRCCONFIG)
4. Read the data from memory locations for which CRC needs to be calculated using mirrored address
5. Read the  $\mu$ CRCRES register to get the calculated CRC value. Pop the last saved value of the CRC from the stack and store this value into the  $\mu$ CRC Result Register ( $\mu$ CRCRES)

#### 6.19.4 CRC Calculation for Data Stored In Secure Memory

This device has dual-zone security for the Cortex-M3 subsystem. Because ZoneX ( $X \rightarrow 1/2$ ) software does not have access to program/data in ZoneY ( $Y \rightarrow 2/1$ ), code running from ZoneX cannot calculate CRC on data stored in ZoneY memory. Similarly, in the case of Exe-Only flash sectors, even though software is running from same secure zone, the software cannot read the data stored in Exe-Only sectors. However, hardware does allow CRC computation on data stored in Exe-Only flash sectors as long as the read access for this data is initiated by code running from same secure zone. These reads are just dummy reads and, in this case, read data only goes to the  $\mu$ CRC module, not to the CPU.

## 7 Applications, Implementation, and Layout

---

### NOTE

Information in the following sections is not part of the TI component specification, and TI does not warrant its accuracy or completeness. TI's customers are responsible for determining suitability of components for their purposes. Customers should validate and test their design implementation to confirm system functionality.

---

### 7.1 TI Design or Reference Design

The TI Designs Reference Design Library is a robust reference design library spanning analog, embedded processor, and connectivity. Created by TI experts to help you jump start your system design, all TI Designs include schematic or block diagrams, BOMs, and design files to speed your time to market. Search and download designs at [TIDesigns](#).

#### [Single-Phase Energy Meter Solution for Advanced Applications](#)

This design features a dual-core microcontroller implementing an integrated electricity metering solution. The meter has been tested to prove 0.5% accuracy across a current dynamic range of 2000:1 by using a precision, low-noise op-amp and a programmable gain amplifier (PGA) to provide four gain stages. The metrology calculations are performed independently of the MCU integrated cores, leaving both MCUs available for other applications, including Power Line Communications (PLC). Developers will benefit from this design by taking advantage of both the ARM<sup>®</sup> Cortex<sup>®</sup>-M3 and C28x MCUs to provide the e-meter host applications and PLC communications.

#### [Power Line Communications \(PLC\) System-on-Module for ARIB Frequency Band](#)

The SOMPLC-F28M35 is a single-board System-on-Module (SOM) for PLC in the ARIB frequency band. This single hardware design supports several popular PLC industry standards, including G3 and IEEE-1901.2. TI's certified PLC software is available along with the SOMPLC-F28M35. Engineers can take the SOM design and integrate it into their overall system board or keep the design as an add-on board to their application. The only additional hardware required is the AC mains line coupling circuitry. The included hardware schematics and Gerber files simplify the task for engineers to add PLC to their end system. OEMs will benefit from having the ability to rapidly evaluate and prototype PLC technology in their application.

## 8 Device and Documentation Support

### 8.1 Device and Development Support Tool Nomenclature

To designate the stages in the product development cycle, TI assigns prefixes to the part numbers of all Concerto MCU devices and support tools. Each Concerto MCU commercial family member has one of three prefixes: x, p, or no prefix (for example, xF28M35H52C1RFPT). Texas Instruments recommends two of three possible prefix designators for its support tools: TMDX and TMDS. These prefixes represent evolutionary stages of product development from engineering prototypes (with prefix **x** for devices and TMDX for tools) through fully qualified production devices/tools (with no prefix for devices and TMDS, instead of TMDX, for tools).

|                   |  |
|-------------------|--|
| <b>xF28M35...</b> | Experimental device that is not necessarily representative of the final device's electrical specifications                           |
| <b>pF28M35...</b> | Final silicon die that conforms to the device's electrical specifications but has not completed quality and reliability verification |
| <b>F28M35...</b>  | Fully qualified production device  |

Support tool development evolutionary flow:

|             |   |
|-------------|---|
| <b>TMDX</b> | Development-support product that has not yet completed Texas Instruments internal qualification testing |
| <b>TMDS</b> | Fully qualified development-support product   |

Devices with prefix **x** or **p** and TMDX development-support tools are shipped against the following disclaimer:

"Developmental product is intended for internal evaluation purposes."

Production devices and TMDS development-support tools have been characterized fully, and the quality and reliability of the device have been demonstrated fully. TI's standard warranty applies.

Predictions show that prototype devices with prefix of **x** or **p** have a greater failure rate than the standard production devices. Texas Instruments recommends that these devices not be used in any production system because their expected end-use failure rate still is undefined. Only qualified production devices are to be used.

TI device nomenclature also includes a suffix with the device family name. This suffix indicates the package type (for example, RFP) and temperature range (for example, T).

For device part numbers and further ordering information of F28M35x devices in the RFP package type, see the TI website ([www.ti.com](http://www.ti.com)) or contact your TI sales representative.

For additional description of the device nomenclature markings on the die, see the [F28M35x Concerto™ MCUs Silicon Errata](#).

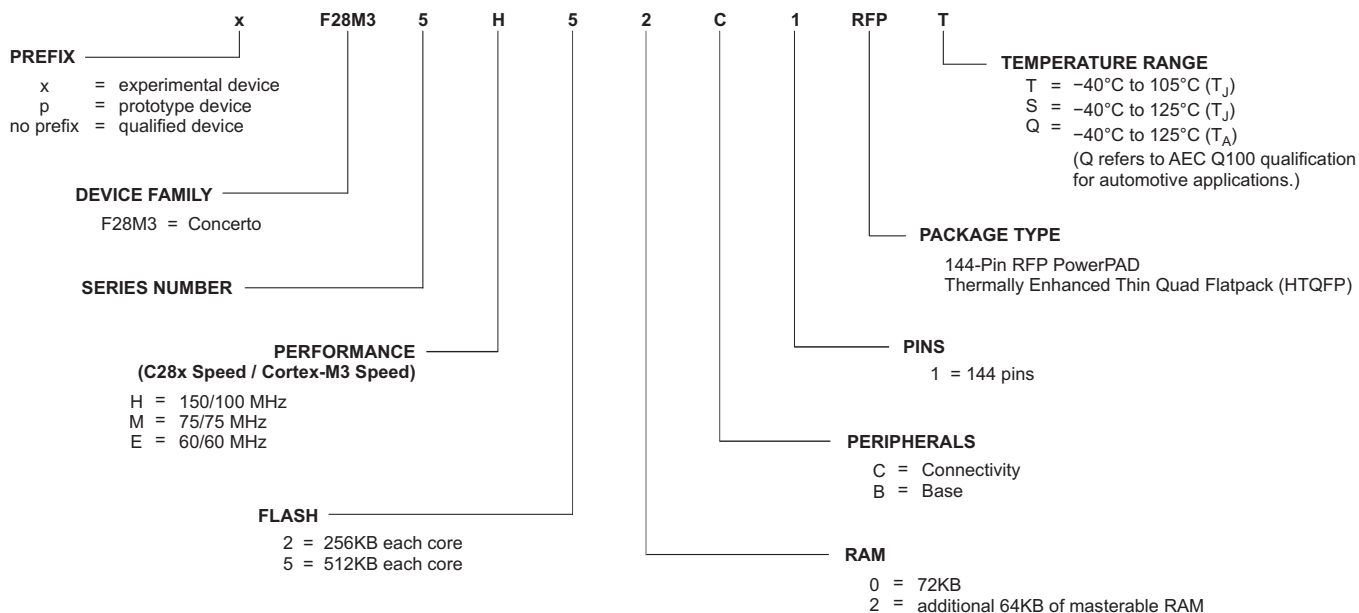

**Figure 8-1. Device Nomenclature**

## 8.2 Tools and Software

TI offers an extensive line of development tools. Some of the tools and software to evaluate the performance of the device, generate code, and develop solutions are listed below. To view all available tools and software for C2000™ real-time control MCUs, visit the [C2000 MCU Tools and Software](#) page.

### Development Tools

#### [H52C1 Concerto Experimenter Kit](#)

The C2000 Experimenter Kits from Texas Instruments are ideal products for initial device exploration and testing. The Concerto H52C1 Experimenter Kit has a docking station that features access to all controlCARD signals, breadboard areas and RS-232 and JTAG connectors. Each kit contains a H52C1 controlCARD. The controlCARD is a complete board level module that utilizes an industry-standard DIMM form factor to provide a low-profile single-board controller solution. Kit is complete with Code Composer Studio™ IDE v4 and USB cable.

#### [H52C1 Concerto controlCARD](#)

The C2000 controlCARDS from Texas Instruments are ideal products for initial software development and short run builds for system prototypes, test stands, and many other projects that require easy access to high-performance controllers. The controlCARDS are complete board-level modules that utilize an industry-standard DIMM form factor to provide a low-profile single-board controller solution. All of the C2000 controlCARDS use the same 100-pin connector footprint to provide the analog and digital I/Os on-board controller and are completely interchangeable. The host system needs to provide only a single 5V power rail to the controlCARD for it to be fully functional.

## Software Tools

[controlSUITE™ Software Suite: Essential Software and Development Tools for C2000™ Microcontrollers](#)  
controlSUITE™ for C2000™ microcontrollers is a cohesive set of software infrastructure and software tools designed to minimize software development time.

[Code Composer Studio™ \(CCS\) Integrated Development Environment \(IDE\) for C2000 Microcontrollers](#)  
Code Composer Studio is an integrated development environment (IDE) that supports TI's Microcontroller and Embedded Processors portfolio. Code Composer Studio comprises a suite of tools used to develop and debug embedded applications. It includes an optimizing C/C++ compiler, source code editor, project build environment, debugger, profiler, and many other features. The intuitive IDE provides a single user interface taking the user through each step of the application development flow. Familiar tools and interfaces allow users to get started faster than ever before. Code Composer Studio combines the advantages of the Eclipse software framework with advanced embedded debug capabilities from TI resulting in a compelling feature-rich development environment for embedded developers.

### [F021 Flash API](#)

The F021 Flash Application Programming Interface (API) provides a software library of functions to program, erase, and verify F021 on-chip Flash memory.

## Models

Various models are available for download from the product Tools & Software pages. These include I/O Buffer Information Specification (IBIS) Models and Boundary-Scan Description Language (BSDL) Models. To view all available models, visit the Models section of the Tools & Software page for each device, which can be found in [Table 8-1](#).

## Training

For support and training, go to <http://www.ti.com/product/F28M35H52C/support>.

## 8.3 Documentation Support

To receive notification of documentation updates, navigate to the device product folder on [ti.com](http://ti.com). In the upper right corner, click on *Alert me* to register and receive a weekly digest of any product information that has changed. For change details, review the revision history included in any revised document.

The current documentation that describes the processor, related peripherals, and other technical collateral is listed below.

### Errata

[F28M35x Concerto™ MCUs Silicon Errata](#) describes known advisories on silicon and provides workarounds.

### Technical Reference Manual

[Concerto F28M35x Technical Reference Manual](#) details the integration, the environment, the functional description, and the programming models for each peripheral and subsystem in the F28M35x Microcontroller Processors.

### CPU User's Guides

[TMS320C28x CPU and Instruction Set Reference Guide](#) describes the central processing unit (CPU) and the assembly language instructions of the TMS320C28x fixed-point digital signal processors (DSPs). This Reference Guide also describes emulation features available on these DSPs.

[TMS320C28x Extended Instruction Sets Technical Reference Manual](#) describes the architecture, pipeline, and instruction set of the TMU, VCU-II, and FPU accelerators.

## Peripheral Guides

[C2000 Real-Time Control Peripherals Reference Guide](#) describes the peripheral reference guides of the 28x DSPs.

## Tools Guides

[TMS320C28x Assembly Language Tools v17.9.0.STS User's Guide](#) describes the assembly language tools (assembler and other tools used to develop assembly language code), assembler directives, macros, common object file format, and symbolic debugging directives for the TMS320C28x device.

[TMS320C28x Optimizing C/C++ Compiler v17.9.0.STS User's Guide](#) describes the TMS320C28x C/C++ compiler. This compiler accepts ANSI standard C/C++ source code and produces TMS320 DSP assembly language source code for the TMS320C28x device.

[TMS320C28x Instruction Set Simulator Technical Overview](#) describes the simulator, available within the Code Composer Studio for TMS320C2000 IDE, that simulates the instruction set of the C28x core.

## Application Reports

[Semiconductor and IC Package Thermal Metrics](#) describes traditional and new thermal metrics and puts their application in perspective with respect to system-level junction temperature estimation.

[Semiconductor Packing Methodology](#) describes the packing methodologies employed to prepare semiconductor devices for shipment to end users.

[Calculating Useful Lifetimes of Embedded Processors](#) provides a methodology for calculating the useful lifetime of TI embedded processors (EPs) under power when used in electronic systems. It is aimed at general engineers who wish to determine if the reliability of the TI EP meets the end system reliability requirement.

[An Introduction to IBIS \(I/O Buffer Information Specification\) Modeling](#) discusses various aspects of IBIS including its history, advantages, compatibility, model generation flow, data requirements in modeling the input/output structures and future trends.

## 8.4 Related Links

The table below lists quick access links. Categories include technical documents, support and community resources, tools and software, and quick access to sample or buy.

**Table 8-1. Related Links**

| PARTS      | PRODUCT FOLDER             | SAMPLE & BUY               | TECHNICAL DOCUMENTS        | TOOLS & SOFTWARE           | SUPPORT & COMMUNITY        |
|------------|----------------------------|----------------------------|----------------------------|----------------------------|----------------------------|
| F28M35H52C | <a href="#">Click here</a> | <a href="#">Click here</a> | <a href="#">Click here</a> | <a href="#">Click here</a> | <a href="#">Click here</a> |
| F28M35H22C | <a href="#">Click here</a> | <a href="#">Click here</a> | <a href="#">Click here</a> | <a href="#">Click here</a> | <a href="#">Click here</a> |
| F28M35M52C | <a href="#">Click here</a> | <a href="#">Click here</a> | <a href="#">Click here</a> | <a href="#">Click here</a> | <a href="#">Click here</a> |
| F28M35M22C | <a href="#">Click here</a> | <a href="#">Click here</a> | <a href="#">Click here</a> | <a href="#">Click here</a> | <a href="#">Click here</a> |
| F28M35M20B | <a href="#">Click here</a> | <a href="#">Click here</a> | <a href="#">Click here</a> | <a href="#">Click here</a> | <a href="#">Click here</a> |
| F28M35E20B | <a href="#">Click here</a> | <a href="#">Click here</a> | <a href="#">Click here</a> | <a href="#">Click here</a> | <a href="#">Click here</a> |

## 8.5 Community Resources

The following links connect to TI community resources. Linked contents are provided "AS IS" by the respective contributors. They do not constitute TI specifications and do not necessarily reflect TI's views; see TI's [Terms of Use](#).

**TI E2E™ Online Community** The TI engineer-to-engineer (E2E) community was created to foster collaboration among engineers. At [e2e.ti.com](http://e2e.ti.com), you can ask questions, share knowledge, explore ideas and help solve problems with fellow engineers.

**TI Embedded Processors Wiki** Established to help developers get started with Embedded Processors from Texas Instruments and to foster innovation and growth of general knowledge about the hardware and software surrounding these devices.

## 8.6 Trademarks

Concerto, PowerPAD, TMS320C2000, Piccolo, Delfino, controlSUITE, Texas Instruments, Code Composer Studio, C2000, E2E are trademarks of Texas Instruments.  
ARM, Cortex are registered trademarks of ARM Limited (or its subsidiaries) in the EU and/or elsewhere.  
All rights reserved.

Freescale is a trademark of Freescale Semiconductor, Inc.

NXP is a registered trademark of NXP Semiconductors.

Bosch is a registered trademark of Robert Bosch GmbH Corporation.

All other trademarks are the property of their respective owners.

## 8.7 Electrostatic Discharge Caution



This integrated circuit can be damaged by ESD. Texas Instruments recommends that all integrated circuits be handled with appropriate precautions. Failure to observe proper handling and installation procedures can cause damage.

ESD damage can range from subtle performance degradation to complete device failure. Precision integrated circuits may be more susceptible to damage because very small parametric changes could cause the device not to meet its published specifications.

## 8.8 Glossary

**TI Glossary** This glossary lists and explains terms, acronyms, and definitions.

## 9 Mechanical, Packaging, and Orderable Information

### 9.1 Packaging Information

The following pages include mechanical, packaging, and orderable information. This information is the most current data available for the designated devices. This data is subject to change without notice and revision of this document. For browser-based versions of this data sheet, refer to the left-hand navigation.

For packages with a thermal pad, the MECHANICAL DATA figure shows a generic thermal pad without dimensions. For the actual thermal pad dimensions that are applicable to this device, see the THERMAL PAD MECHANICAL DATA figure.

**PACKAGING INFORMATION**

| Orderable Device | Status<br>(1) | Package Type | Package<br>Drawing | Pins | Package<br>Qty | Eco Plan<br>(2)            | Lead/Ball Finish<br>(6) | MSL Peak Temp<br>(3) | Op Temp (°C) | Device Marking<br>(4/5) | Samples                 |
|------------------|---------------|--------------|--------------------|------|----------------|----------------------------|-------------------------|----------------------|--------------|-------------------------|-------------------------|
| F28M35E20B1RFPS  | ACTIVE        | HTQFP        | RFP                | 144  | 60             | Green (RoHS<br>& no Sb/Br) | CU NIPDAU               | Level-3-260C-168 HR  | -40 to 125   | F28M35E20B1RFPS         | <a href="#">Samples</a> |
| F28M35E20B1RFPT  | ACTIVE        | HTQFP        | RFP                | 144  | 60             | Green (RoHS<br>& no Sb/Br) | CU NIPDAU               | Level-3-260C-168 HR  | -40 to 105   | F28M35E20B1RFPT         | <a href="#">Samples</a> |
| F28M35H22C1RFPS  | ACTIVE        | HTQFP        | RFP                | 144  | 60             | Green (RoHS<br>& no Sb/Br) | CU NIPDAU               | Level-3-260C-168 HR  | -40 to 125   | F28M35H22C1RFPS         | <a href="#">Samples</a> |
| F28M35H22C1RFPT  | ACTIVE        | HTQFP        | RFP                | 144  | 60             | Green (RoHS<br>& no Sb/Br) | CU NIPDAU               | Level-3-260C-168 HR  | -40 to 105   | F28M35H22C1RFPT         | <a href="#">Samples</a> |
| F28M35H52C1RFPQ  | ACTIVE        | HTQFP        | RFP                | 144  | 60             | Green (RoHS<br>& no Sb/Br) | CU NIPDAU               | Level-3-260C-168 HR  | -40 to 125   | F28M35H52C1RFPQ         | <a href="#">Samples</a> |
| F28M35H52C1RFPS  | ACTIVE        | HTQFP        | RFP                | 144  | 60             | Green (RoHS<br>& no Sb/Br) | CU NIPDAU               | Level-3-260C-168 HR  | -40 to 125   | F28M35H52C1RFPS         | <a href="#">Samples</a> |
| F28M35H52C1RFPT  | ACTIVE        | HTQFP        | RFP                | 144  | 60             | Green (RoHS<br>& no Sb/Br) | CU NIPDAU               | Level-3-260C-168 HR  | -40 to 105   | F28M35H52C1RFPT         | <a href="#">Samples</a> |
| F28M35M22C1RFPS  | ACTIVE        | HTQFP        | RFP                | 144  | 60             | Green (RoHS<br>& no Sb/Br) | CU NIPDAU               | Level-3-260C-168 HR  | -40 to 125   | F28M35M22C1RFPS         | <a href="#">Samples</a> |
| F28M35M22C1RFPT  | ACTIVE        | HTQFP        | RFP                | 144  | 60             | Green (RoHS<br>& no Sb/Br) | CU NIPDAU               | Level-3-260C-168 HR  | -40 to 105   | F28M35M22C1RFPT         | <a href="#">Samples</a> |
| F28M35M52C1RFPS  | ACTIVE        | HTQFP        | RFP                | 144  | 60             | Green (RoHS<br>& no Sb/Br) | CU NIPDAU               | Level-3-260C-168 HR  | -40 to 125   | F28M35M52C1RFPS         | <a href="#">Samples</a> |
| F28M35M52C1RFPT  | ACTIVE        | HTQFP        | RFP                | 144  | 60             | Green (RoHS<br>& no Sb/Br) | CU NIPDAU               | Level-3-260C-168 HR  | -40 to 105   | F28M35M52C1RFPT         | <a href="#">Samples</a> |

(1) The marketing status values are defined as follows:

**ACTIVE:** Product device recommended for new designs.

**LIFEBUY:** TI has announced that the device will be discontinued, and a lifetime-buy period is in effect.

**NRND:** Not recommended for new designs. Device is in production to support existing customers, but TI does not recommend using this part in a new design.

**PREVIEW:** Device has been announced but is not in production. Samples may or may not be available.

**OBSOLETE:** TI has discontinued the production of the device.

(2) **RoHS:** TI defines "RoHS" to mean semiconductor products that are compliant with the current EU RoHS requirements for all 10 RoHS substances, including the requirement that RoHS substance do not exceed 0.1% by weight in homogeneous materials. Where designed to be soldered at high temperatures, "RoHS" products are suitable for use in specified lead-free processes. TI may reference these types of products as "Pb-Free".

**RoHS Exempt:** TI defines "RoHS Exempt" to mean products that contain lead but are compliant with EU RoHS pursuant to a specific EU RoHS exemption.

**Green:** TI defines "Green" to mean the content of Chlorine (Cl) and Bromine (Br) based flame retardants meet JS709B low halogen requirements of <=1000ppm threshold. Antimony trioxide based flame retardants must also meet the <=1000ppm threshold requirement.

- (3) MSL, Peak Temp. - The Moisture Sensitivity Level rating according to the JEDEC industry standard classifications, and peak solder temperature.
- (4) There may be additional marking, which relates to the logo, the lot trace code information, or the environmental category on the device.
- (5) Multiple Device Markings will be inside parentheses. Only one Device Marking contained in parentheses and separated by a "~" will appear on a device. If a line is indented then it is a continuation of the previous line and the two combined represent the entire Device Marking for that device.
- (6) Lead/Ball Finish - Orderable Devices may have multiple material finish options. Finish options are separated by a vertical ruled line. Lead/Ball Finish values may wrap to two lines if the finish value exceeds the maximum column width.

**Important Information and Disclaimer:**The information provided on this page represents TI's knowledge and belief as of the date that it is provided. TI bases its knowledge and belief on information provided by third parties, and makes no representation or warranty as to the accuracy of such information. Efforts are underway to better integrate information from third parties. TI has taken and continues to take reasonable steps to provide representative and accurate information but may not have conducted destructive testing or chemical analysis on incoming materials and chemicals. TI and TI suppliers consider certain information to be proprietary, and thus CAS numbers and other limited information may not be available for release.

In no event shall TI's liability arising out of such information exceed the total purchase price of the TI part(s) at issue in this document sold by TI to Customer on an annual basis.

# MECHANICAL DATA

RFP (S-PQFP-G144)

PowerPAD™ PLASTIC QUAD FLATPACK

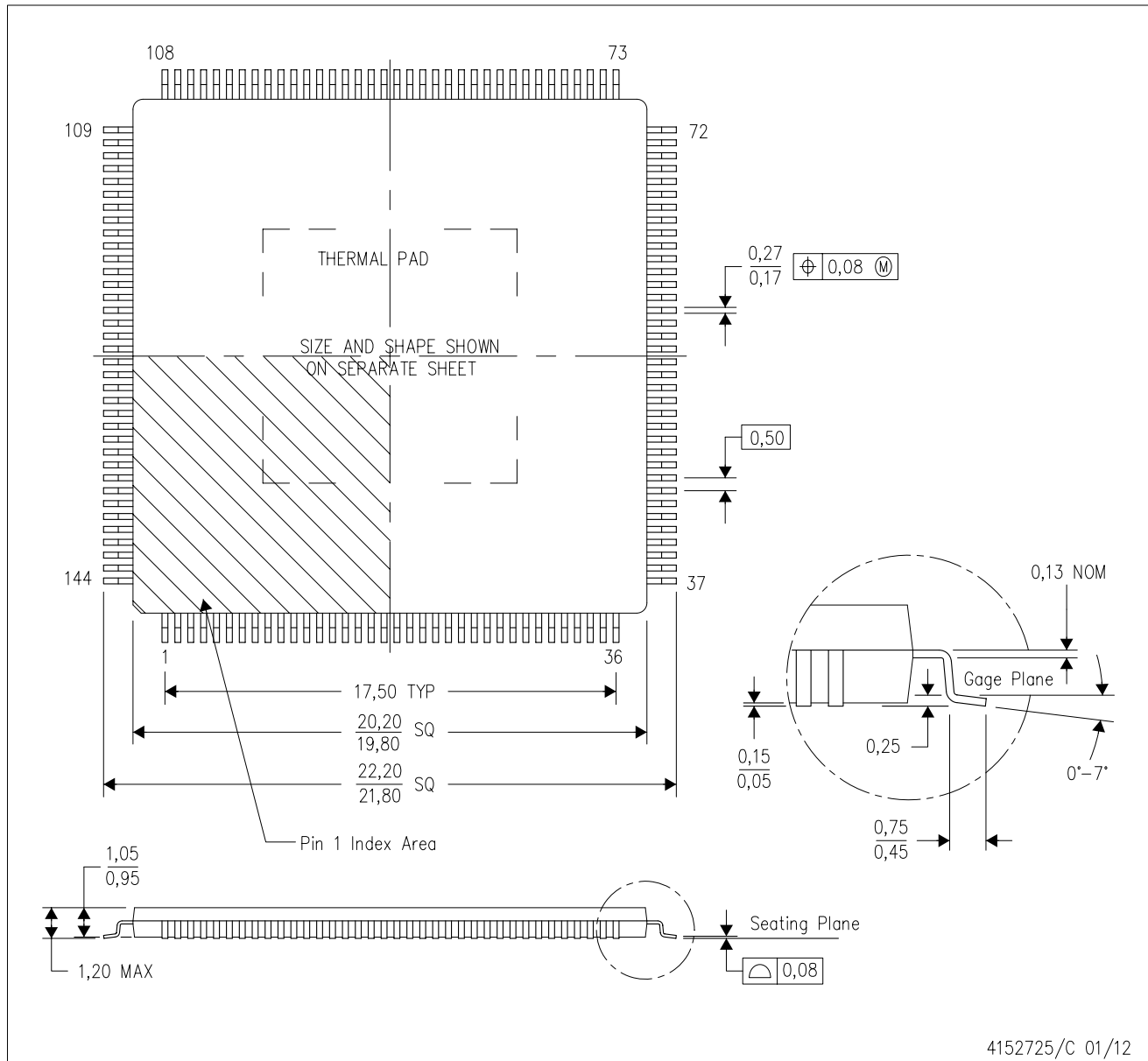

- NOTES:
- All linear dimensions are in millimeters.
  - This drawing is subject to change without notice.
  - Body dimensions do not include mold flash or protrusion
  - This package is designed to be soldered to a thermal pad on the board. Refer to Technical Brief, PowerPad Thermally Enhanced Package, Texas Instruments Literature No. SLMA002 for information regarding recommended board layout. This document is available at [www.ti.com](http://www.ti.com) <<http://www.ti.com>>.
  - See the additional figure in the Product Data Sheet for details regarding the exposed thermal pad features and dimensions.
  - Falls within JEDEC MS-026

PowerPAD is a trademark of Texas Instruments.

# THERMAL PAD MECHANICAL DATA

RFP (S-PQFP-G144)

PowerPAD™ PLASTIC QUAD FLATPACK

## THERMAL INFORMATION

This PowerPAD™ package incorporates an exposed thermal pad that is designed to be attached to a printed circuit board (PCB). The thermal pad must be soldered directly to the PCB. After soldering, the PCB can be used as a heatsink. In addition, through the use of thermal vias, the thermal pad can be attached directly to the appropriate copper plane shown in the electrical schematic for the device, or alternatively, can be attached to a special heatsink structure designed into the PCB. This design optimizes the heat transfer from the integrated circuit (IC).

For additional information on the PowerPAD package and how to take advantage of its heat dissipating abilities, refer to Technical Brief, PowerPAD Thermally Enhanced Package, Texas Instruments Literature No. SLMA002 and Application Brief, PowerPAD Made Easy, Texas Instruments Literature No. SLMA004. Both documents are available at [www.ti.com](http://www.ti.com).

The exposed thermal pad dimensions for this package are shown in the following illustration.

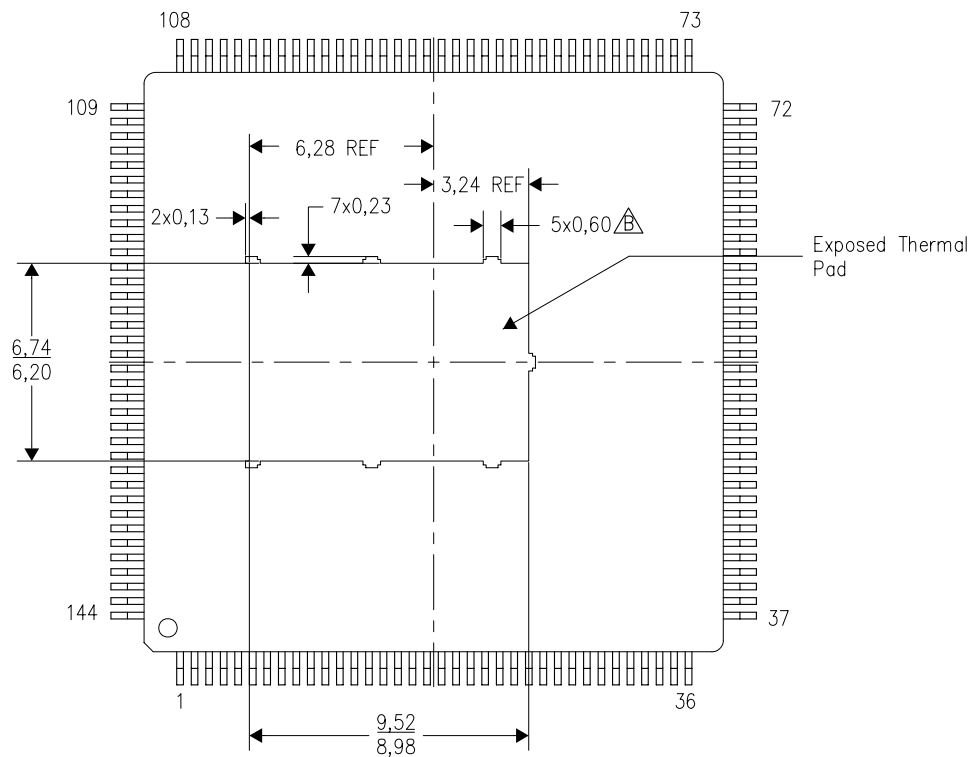

Top View

Exposed Thermal Pad Dimensions

4206900-12/E 01/12

NOTES: A. All linear dimensions are in millimeters

B. Tie strap features may not be present

PowerPAD is a trademark of Texas Instruments.

## IMPORTANT NOTICE AND DISCLAIMER

TI PROVIDES TECHNICAL AND RELIABILITY DATA (INCLUDING DATASHEETS), DESIGN RESOURCES (INCLUDING REFERENCE DESIGNS), APPLICATION OR OTHER DESIGN ADVICE, WEB TOOLS, SAFETY INFORMATION, AND OTHER RESOURCES "AS IS" AND WITH ALL FAULTS, AND DISCLAIMS ALL WARRANTIES, EXPRESS AND IMPLIED, INCLUDING WITHOUT LIMITATION ANY IMPLIED WARRANTIES OF MERCHANTABILITY, FITNESS FOR A PARTICULAR PURPOSE OR NON-INFRINGEMENT OF THIRD PARTY INTELLECTUAL PROPERTY RIGHTS.

These resources are intended for skilled developers designing with TI products. You are solely responsible for (1) selecting the appropriate TI products for your application, (2) designing, validating and testing your application, and (3) ensuring your application meets applicable standards, and any other safety, security, or other requirements. These resources are subject to change without notice. TI grants you permission to use these resources only for development of an application that uses the TI products described in the resource. Other reproduction and display of these resources is prohibited. No license is granted to any other TI intellectual property right or to any third party intellectual property right. TI disclaims responsibility for, and you will fully indemnify TI and its representatives against, any claims, damages, costs, losses, and liabilities arising out of your use of these resources.

TI's products are provided subject to TI's Terms of Sale ([www.ti.com/legal/termsofsale.html](http://www.ti.com/legal/termsofsale.html)) or other applicable terms available either on [ti.com](http://ti.com) or provided in conjunction with such TI products. TI's provision of these resources does not expand or otherwise alter TI's applicable warranties or warranty disclaimers for TI products.

Mailing Address: Texas Instruments, Post Office Box 655303, Dallas, Texas 75265  
Copyright © 2019, Texas Instruments Incorporated

## Looking for pricing, stock, or lifecycle information?

Click below to explore more details on WIN SOURCE:

 [View F28M35H52C1RFPQ on WIN SOURCE](#)

 [Texas Instruments](#) Information

## Optimize Your Supply Chain with WIN SOURCE Solutions

-  Global Sourcing Solution
-  Obsolete Management
-  Cost Control Management
-  Shortage Management
-  Alternative Solution
-  Excess Inventory Management