



# THE DATASHEET OF EVB-EP53F8QI





# Enpirion<sup>®</sup> Power Datasheet

## EP53F8QI 1500 mA PowerSoC

### Voltage Mode Synchronous PWM Buck with Integrated Inductor

#### Description

The EP53F8QI provides high efficiency in a very small footprint. Featuring integrated inductor, the device delivers up to 1500mA of continuous output current. Total solution footprint can be as little as 40mm<sup>2</sup>.

Output voltage is programmed via an external resistor divider providing a wide range of flexibility while maintaining a very small footprint.

Integration of the inductor reduces conducted and radiated noise providing excellent compatibility with sensitive RF and high speed data applications.

#### Features

- **Integrated Inductor Technology**
- Total Solution Footprint as Small as 40 mm<sup>2</sup>
- 3 mm x 3 mm x 1.1 mm QFN Package
- Solution Power Density up to 140mW/mm<sup>2</sup>
- 1500 mA Continuous Output Current
- High Efficiency, up to 94 %
- Low Ripple Voltage; 8 mV<sub>P-P</sub> Typical
- Power OK Signal with 5 mA Sink Capability
- 2.4V to 5.5V Input Voltage Range
- Fast Transient Response
- 4 MHz Fixed Switching Frequency
- Low Dropout Operation: 100 % Duty Cycle
- Under Voltage Lockout, Over Current, Short Circuit, and Thermal Protection
- RoHS Compliant; MSL 3 260 °C Reflow

#### Application

- Wireless wide area networking data cards.
- Replacement of inefficient LDOs
- Noise Sensitive Applications such as RF, Audio and Video, and high speed IO
- Computing, Computer Peripherals, Storage, Networking, and Instrumentation
- USB, DSL, STB, DVR, DTV, and iPC

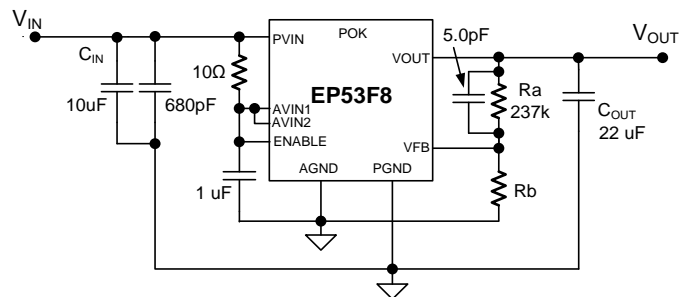

Figure 1: Typical Application Circuit

#### Product Performance

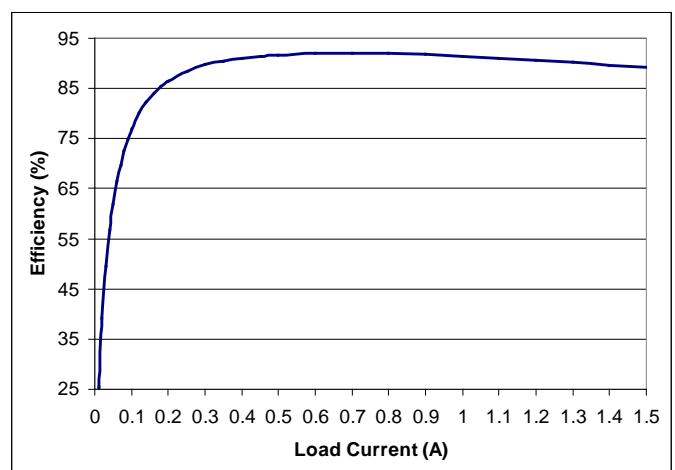

Figure 2: Efficiency, V<sub>IN</sub>=5V, V<sub>OUT</sub>=3.7V

## Ordering Information

Part Number	Temp Rating (°C)	Package
EP53F8QI	-40 to +85	16-pin QFN T&R
EVB-EP53F8QI	QFN Evaluation Board	

## Pin Assignments (Top View)

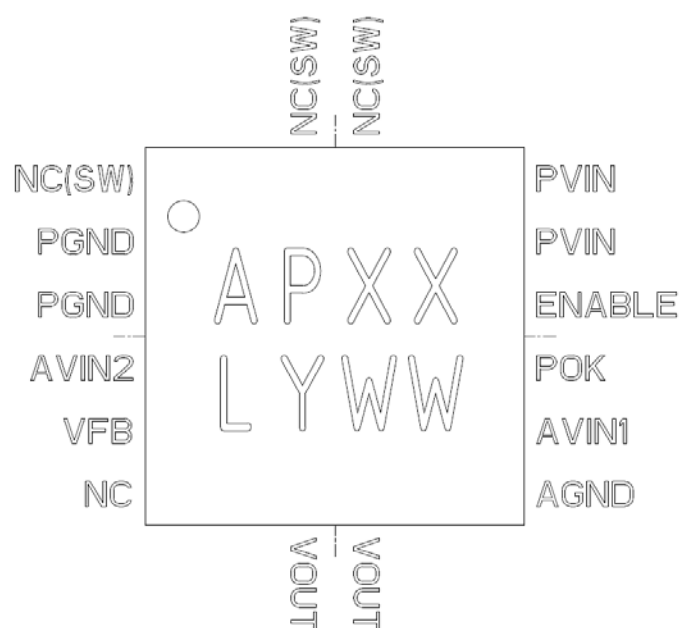

Figure 3: Pin Diagram (Top View)

## Pin Description

PIN	NAME	FUNCTION
1, 15,16	NC(SW)	No Connect. These pins are internally connected to the common drain output of the internal MOSFETs. NC(SW) pins are not to be electrically connected to any external signal, ground, or voltage. However, they must be soldered to the PCB. Failure to follow this guideline may result in part malfunction or damage.
2-3,	PGND	Input/Output Power Ground. Connect these pins to the ground electrode of the input and output filter capacitors. Refer to Layout Considerations section for details.
4	AVIN2	Analog input voltage. Connect to AVIN1 only.
5	VFB	Feedback Pin for External Voltage Divider Network. Connect a resistor divider to this pin to set the output voltage. Use 237 k $\Omega$ , 1% or better for the upper resistor.
6	NC	No Connect.
7,8	VOUT	Voltage and Power Output. Connect these pins to output capacitor(s).
9	AGND	Analog Ground for the Controller Circuits
10	AVIN1	Analog Voltage Input for the Controller Circuits. Connect this pin to PVIN with a 10 $\Omega$ resistor. Connect a 1 $\mu$ F capacitor between this pin and AGND. Connect AVIN2 to this pin.
11	POK	Power OK with an Open Drain Output. Refer to Power OK section.
12	ENABLE	Input Enable. A logic high signal on this pin enables the output and initiates a soft start. A logic low signal disables the output and discharges the output to GND. The ENABLE pin should not be left floating as it could be in an unknown and random state. It is recommended to enable the device after both PVIN and AVIN is in regulation. See ENABLE operation for details.
13-14	PVIN	Input Power Supply. Connect to input supply. Decouple with input capacitor(s) to PGND.

## Absolute Maximum Ratings

CAUTION: Absolute Maximum ratings are stress ratings only. Functional operation beyond the recommended operating conditions is not implied. Stress beyond the absolute maximum ratings may cause permanent damage to the device. Exposure to absolute maximum rated conditions for extended periods may affect device reliability.

Absolute Maximum Electrical Ratings	MIN	MAX
Voltages on: PVIN, AVIN, VOUT	-0.3 V	6.5 V
Voltages on: ENABLE, POK	-0.3 V	$V_{IN}$
Voltage on: VFB	-0.3 V	2.7 V
ESD Rating (Human Body Model)	2 kV	
ESD Rating (Charge Device Model)	500 V	
Absolute Maximum Thermal Ratings	MIN	MAX
Ambient Operating Range	-40 °C	+85 °C
Storage Temperature Range	-65 °C	+150 °C
Reflow Peak Body Temperature MSL3 (10 s)		+260 °C

## Recommended Operating Conditions

PARAMETER	SYMBOL	MIN	MAX	UNITS
Input Voltage Range	$V_{IN}$	2.4	5.5	V
Output Voltage Range	$V_{OUT}$	0.6	$V_{IN} - V_{DROPOUT}^{\dagger}$	V
Output Current	$I_{LOAD}$	0	1500	mA
Operating Junction Temperature	$T_J$	-40	+125	°C
Operating Ambient Temperature	$T_A$	-40	+85	°C

<sup>†</sup>  $V_{DROPOUT}$  is defined as ( $I_{LOAD} \times \text{Dropout Resistance}$ ) including temperature effect

## Thermal Characteristics

PARAMETER	SYMBOL	MIN	TYP	MAX	UNITS
Thermal Shutdown (Junction Temperature)	$T_{SD}$		155		°C
Thermal Shutdown Hysteresis	$T_{SDH}$		15		°C
Thermal Resistance: Junction to Ambient (0 LFM) <sup>††</sup>	$\theta_{JA}$		55		°C/W

<sup>††</sup> Based on a 2 oz. copper board and proper thermal design in line with JEDEC EIJ/JESD51 standards

## Electrical Characteristics

NOTE:  $T_A = -40^{\circ}\text{C}$  to  $+85^{\circ}\text{C}$  unless otherwise noted. Typical values for  $V_{IN} = 5\text{V}$  and  $T_A = 25^{\circ}\text{C}$ , unless otherwise noted.

PARAMETER	SYMBOL	TEST CONDITIONS	MIN	TYP	MAX	UNITS
Operating Input Voltage	$V_{IN}$		2.4		5.5	V
Under Voltage Lockout	$V_{UVLO}$	$V_{IN}$ going low to high		2.2		V
Under Voltage Lockout	$V_{UVLO}$	$V_{IN}$ going high to low		2.1		V
VFB Voltage Initial Accuracy	$V_{FB}$	$T_A = 25^{\circ}\text{C}$ ; $V_{IN} = 5\text{V}$ $I_{LOAD} = 100\text{ mA}$	0.588	0.600	0.612	V
Line Regulation		$2.4\text{ V} \leq V_{IN} \leq 5.5\text{V}$		0.31		%/V
Load Regulation		$I_{LOAD} = 0$ to $1.5\text{A}$		0.420		%/A
Temperature Variation		$-40^{\circ}\text{C} \leq T_A \leq +85^{\circ}\text{C}$		0.0012		%/°C
Typical Accuracy		$-40^{\circ}\text{C} \leq T_A \leq +85^{\circ}\text{C}$ ; $0.5\text{A} \leq I_{LOAD} \leq 1.0\text{A}$ ; $4.5\text{V} \leq V_{IN} \leq 5.5\text{V}$ ; $0.95\text{V} \leq V_{OUT} \leq 1.5\text{V}$ ;		1.5		%
$V_{OUT}$ Rise Time	$T_{RISE}$	From time ENABLE goes high	0.78	1.2	1.62	mS
VFB, ENABLE, Pin Input Current (Note 1)		$-40^{\circ}\text{C} \leq T_A \leq +85^{\circ}\text{C}$	-40		+40	nA
ENABLE Voltage Threshold		Logic Low	0.0		0.4	V
		Logic High	1.4		$V_{IN}$	V
Continuous Output Current					1500	mA
Peak Output Current		$1.0\text{V} \leq V_{OUT} \leq 1.5\text{V}$ ; <21ms			1800	mA
POK Upper Threshold		$V_{OUT}$ Rising		111		%
POK Upper Threshold		$V_{OUT}$ Falling		102		%
POK Lower Threshold		$V_{OUT}$ Rising; percent of $V_{OUT}$ Nominal		92		%
POK Lower Threshold		$V_{OUT}$ Falling; percent of $V_{OUT}$ Nominal		90		%
POK Low Voltage		$I_{SINK} = 5\text{ mA}$ , $-40^{\circ}\text{C} \leq T_A \leq +85^{\circ}\text{C}$		0.15	0.4	V
POK Pin $V_{OH}$ Leakage Current		POK High, $-40^{\circ}\text{C} \leq T_A \leq +85^{\circ}\text{C}$			500	nA
Shutdown Current		ENABLE Low		14		$\mu\text{A}$
Current Limit Threshold		$2.4\text{ V} \leq V_{IN} \leq 5.5\text{ V}$ , $-40^{\circ}\text{C} \leq T_A \leq +85^{\circ}\text{C}$	2.0	3.2		A
Dropout Resistance				250	360	$\text{m}\Omega$
Operating Frequency	$F_{OSC}$			4		MHz

**Note 1:** VFB, ENABLE pin input current specification is guaranteed by design.

# Typical Performance Characteristics<sup>†††</sup>

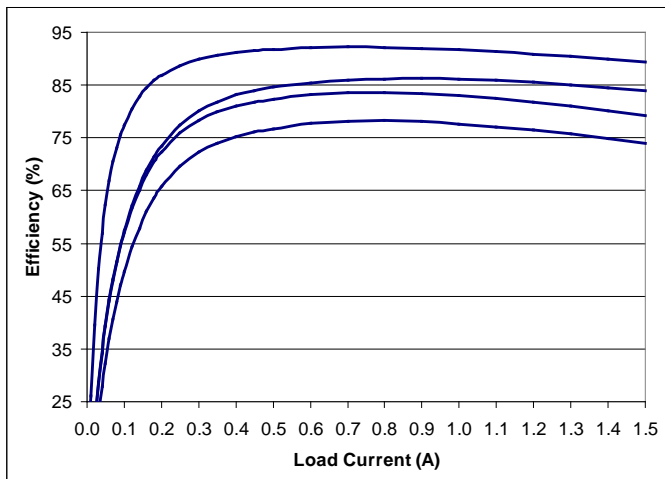

Efficiency vs. Load Current:  $V_{IN} = 5.0V$ ,  $V_{OUT}$  (from top to bottom) = 3.7, 2.5V, 1.8V, 1.2V

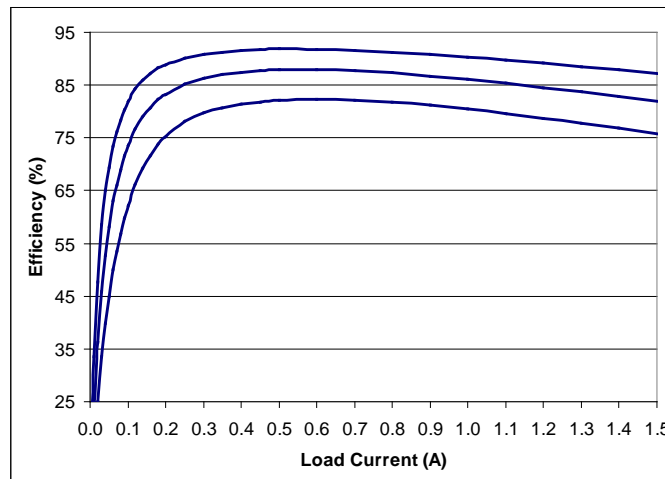

Efficiency vs. Load Current:  $V_{IN} = 3.3V$ ,  $V_{OUT}$  (from top to bottom) = 2.5V, 1.8V, 1.2V

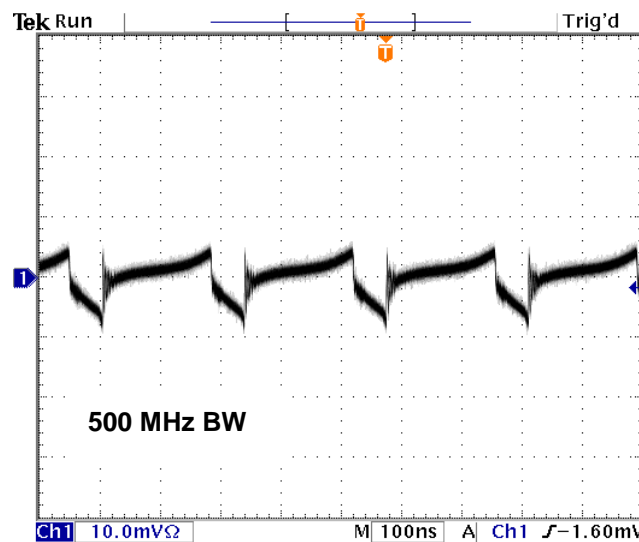
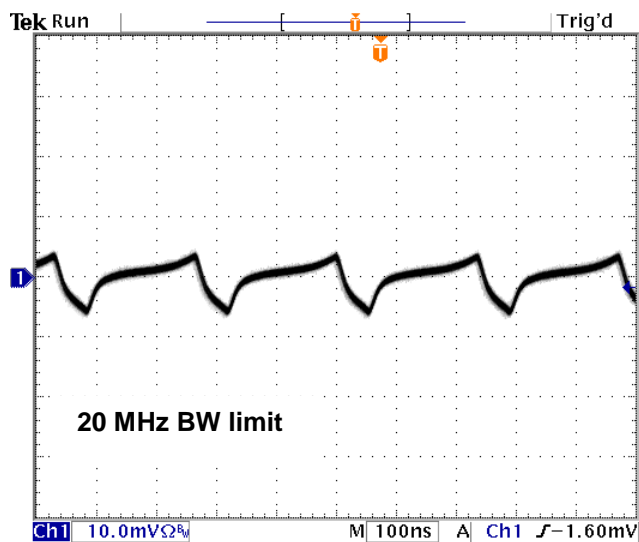

Output Ripple:  $V_{IN} = 5V$ ,  $V_{OUT} = 3.7V$ ,  $I_{LOAD} = 900mA$

Output Ripple:  $V_{IN} = 5V$ ,  $V_{OUT} = 3.7V$ ,  $I_{LOAD} = 900mA$

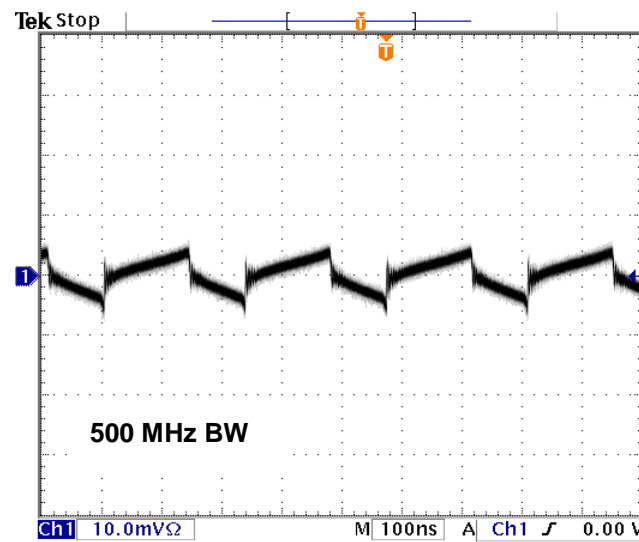
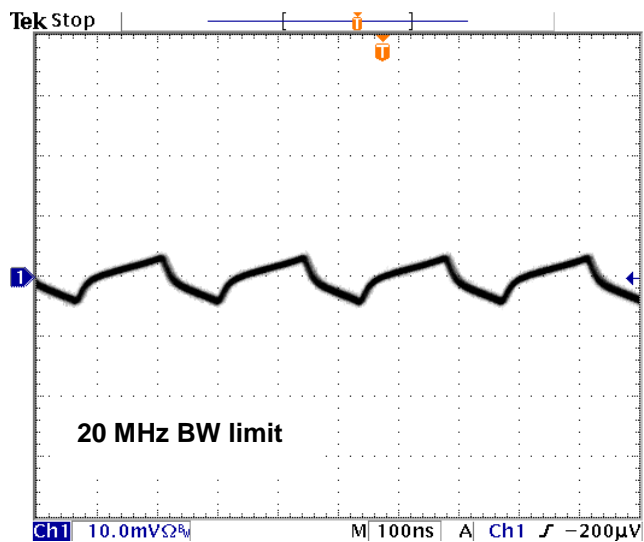

Output Ripple:  $V_{IN} = 3.3V$ ,  $V_{OUT} = 1.8V$ ,  $I_{LOAD} = 900mA$

Output Ripple:  $V_{IN} = 3.3V$ ,  $V_{OUT} = 1.8V$ ,  $I_{LOAD} = 900mA$

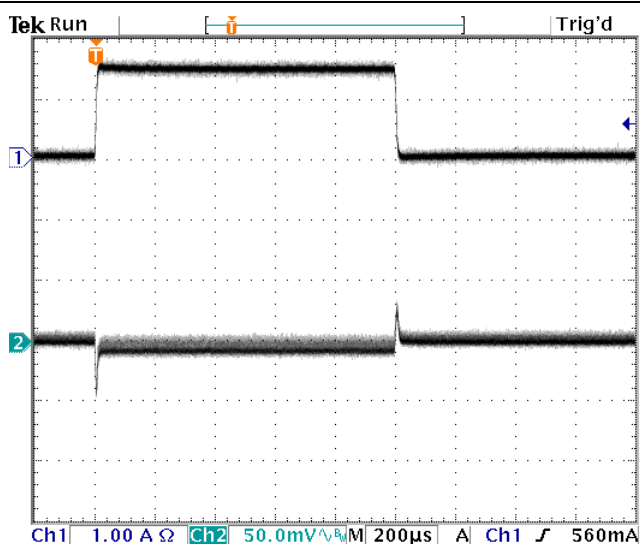

Transient Response:  $V_{IN} = 5.0V$ ,  $V_{OUT} = 1.2V$   
Load Step 0 to 1.5A

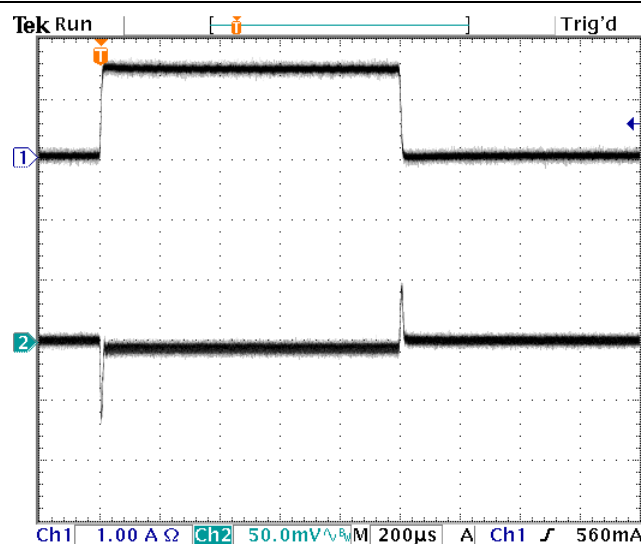

Transient Response:  $V_{IN} = 3.3V$ ,  $V_{OUT} = 1.8V$   
Load Step 0 to 1.5A

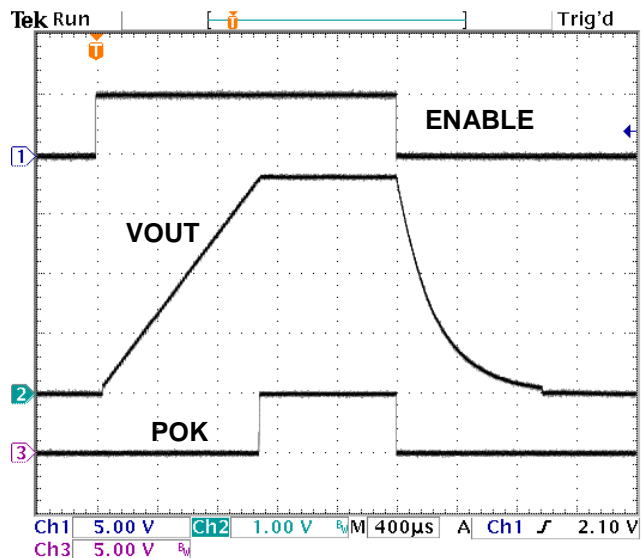

Startup and Shutdown Waveform  
 $V_{IN} = 5.0V$ ,  $V_{OUT} = 3.7V$ ,  $I_{LOAD} = 0mA$

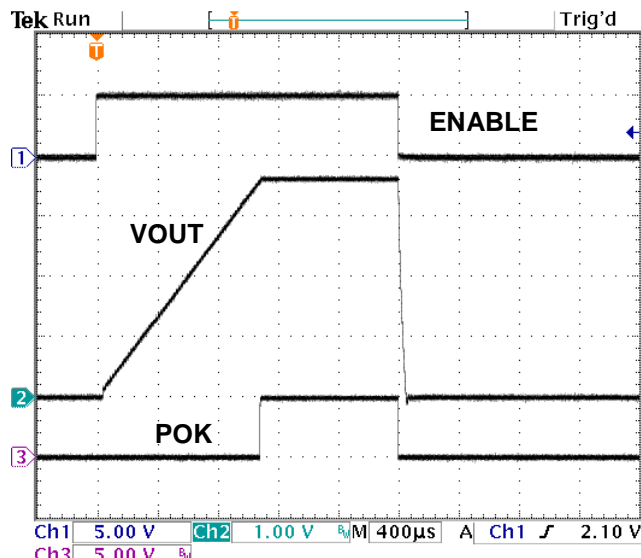

Startup and Shutdown Waveform  
 $V_{IN} = 5.0V$ ,  $V_{OUT} = 3.7V$ ,  $I_{LOAD} = 900mA$

†††Application Circuit in Figure 1 used for typical performance characteristics.

## Functional Block Diagram

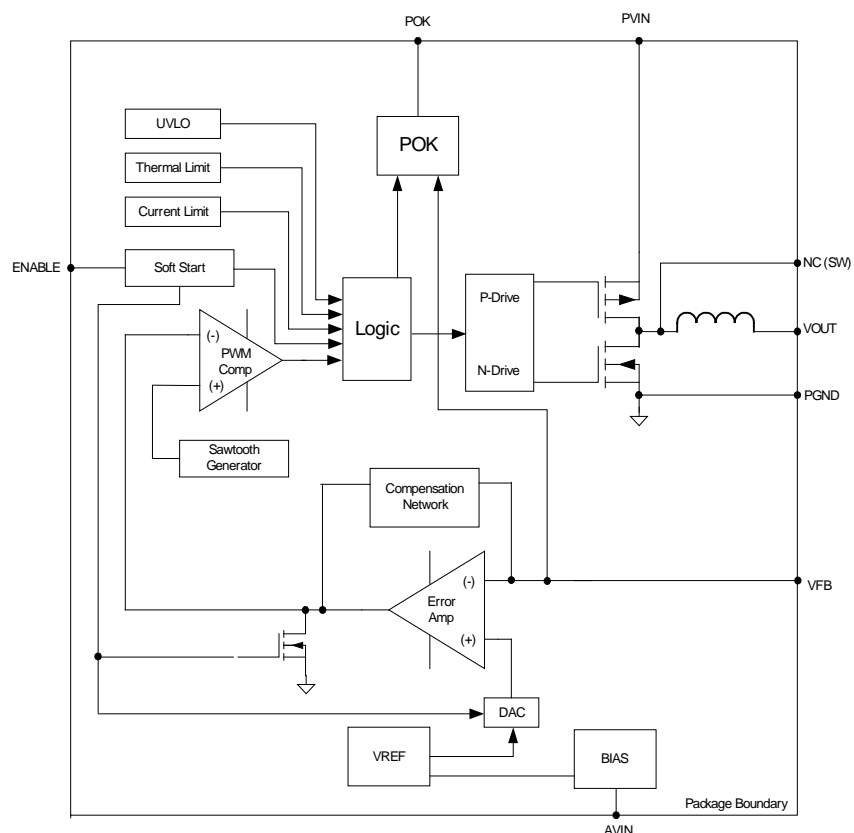

Figure 4: Functional Block Diagram

## Functional Description

The EP53F8QI leverages advanced CMOS technology to provide high switching frequency, while also maintaining high efficiency.

Packaged in a 3 mm x 3 mm x 1.1 mm QFN, the EP53F8QI provides a high degree of flexibility in circuit design while maintaining a very small footprint. High switching frequency allows for the use of very small MLCC input and output filter capacitors.

The converter uses voltage mode control to provide high noise immunity, low output impedance and excellent load transient response. Most compensation components are integrated into the device, requiring only a single external compensation capacitor.

Output voltage is programmed via an external resistor divider. Output voltage can be programmed from 0.6V to  $V_{IN} - V_{DROPOUT}$ .

POK monitors the output voltage and signals if

it is within  $\pm 10\%$  of nominal. Protection features include under voltage lockout (UVLO), over current protection, short circuit protection, and thermal overload protection.

### Stability over Wide Range of Operating Conditions

The EP53F8QI utilizes an internal compensation network and is designed to provide stable operation over a wide range of operating conditions. The high switching frequency allows for a wide control loop bandwidth. To improve transient performance or reduce output voltage ripple with dynamic loads you have the option to add supplementary capacitance to the output. Please refer to the section on soft start for limitations on output capacitance.

## Soft Start

The EP53F8QI has an internal soft-start circuit that controls the ramp of the output voltage. The control circuitry limits the  $V_{OUT}$  ramp rate to levels that are safe for the Power MOSFETS and the integrated inductor.

The device has a constant  $V_{OUT}$  ramp time. Therefore, the ramp rate will vary with the output voltage setting. Output voltage ramp time is given in the Electrical Characteristics Table.

Excess bulk capacitance on the output of the device can cause an over-current condition at startup. The maximum total capacitance on the output, including the output filter capacitor and bulk and decoupling capacitance, at the load, is given as:

$$C_{OUT\_TOTAL\_MAX} = 1.867 \times 10^{-3} / V_{OUT} \text{ Farads}$$

The nominal value for  $C_{OUT}$  is 22 $\mu$ F.

The above number and formula assume a no load condition at startup.

## Over Current/Short Circuit Protection

When an over current condition occurs,  $V_{OUT}$  is pulled low. This condition is maintained for a period of 1.2 ms and then a normal soft start cycle is initiated. If the over current condition still persists, this cycle will repeat.

## Under Voltage Lockout

An under voltage lockout circuit will hold off switching during initial power up until the input voltage reaches sufficient level to ensure proper operation. If the voltage drops below the UVLO threshold the lockout circuitry will again disable switching. Hysteresis is included to prevent chattering between UVLO high and low states.

## Enable

The ENABLE pin provides means to shut down the converter or initiate normal operation. A logic high will enable the converter to go through the soft start cycle and regulate the

output voltage to the desired value. A logic low will allow the device to discharge the output and go into shutdown mode for minimal power consumption. When the output is discharged, an auxiliary NFET turns on and limits the discharge current to 300 mA or below. The ENABLE pin should not be left floating as it could be in an unknown and random state. It is recommended to enable the device after both  $P_{VIN}$  and  $A_{VIN}$  is in regulation. At extremely cold conditions below  $-30^{\circ}\text{C}$ , the controller may not be properly powered if ENABLE is tied directly to  $A_{VIN}$  during startup. It is recommended to use an external RC circuit to delay the ENABLE voltage rise so that the internal controller has time to startup into regulation (see circuit below). The RC circuit may be adjusted so that  $A_{VIN}$  and  $P_{VIN}$  are above UVLO before ENABLE is high. The startup time will be delayed by the extra time it takes for the capacitor voltage to reach the ENABLE threshold.

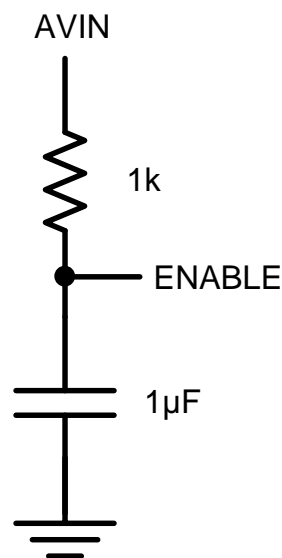

Figure 5: ENABLE Delay Circuit

## Thermal Shutdown

When excessive power is dissipated in the device, its junction temperature rises. Once the junction temperature exceeds the thermal shutdown temperature, the thermal shutdown circuit turns off the converter, allowing the device to cool. When the junction temperature decreases to a safe operating level, the device will be re-enabled and go through a normal

---

startup process. The specific thermal shutdown junction temperature and hysteresis can be found in the thermal characteristics table

### **Power OK**

The EP53F8QI provides an open drain output to indicate if the output voltage stays within 92% to 111% of the set value. Within this range, the POK output is allowed to be pulled high. Outside this range, POK remains low. However, during transitions such as power up, power down, and dynamic voltage scaling, the POK output will not change state until the transition is complete for enhanced noise immunity.

The POK has 5 mA sink capability for events where it needs to feed a digital controller with standard CMOS inputs. When POK is pulled high, the pin leakage current is as low as 500 nA maximum over temperature. This allows a large pull up resistor such as 100 k $\Omega$  to be used for minimal current consumption in shutdown mode.

The POK output can also be conveniently used as an ENABLE input of the next stage for power sequencing of multiple converters.

## Application Information

### Setting the Output Voltage

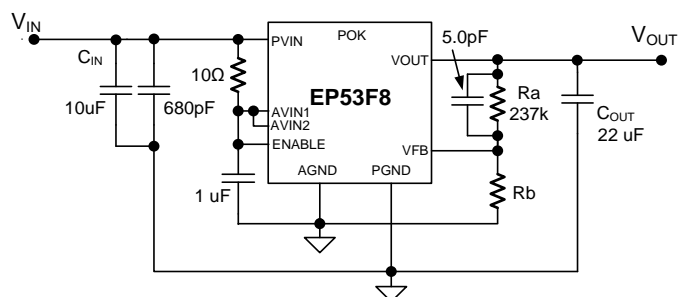

**Figure 6: Typical Application Circuit**

The EP53F8QI uses a simple resistor divider to program the output voltage.

Referring to Figure , use 237 kΩ, 1% or better for the upper resistor (Ra). The value of the bottom resistor (Rb) in kΩ is given as:

$$Rb = \frac{142.2}{V_{OUT} - 0.6} k\Omega$$

Where  $V_{OUT}$  is the output voltage. Rb should also be a 1% or better resistor.

A 5.0pF MLCC capacitor is required in parallel with Ra for compensation.

### Power-Up/Down

During power-up, ENABLE should not be asserted before PVIN, and PVIN should not be asserted before AVIN. The PVIN should never be powered when AVIN is off. During power down, the AVIN should not be powered down before the PVIN. Tying PVIN and AVIN or all three pins (AVIN, PVIN, ENABLE) together during power up or power down meets these requirements.

The EP53F8QI supports startup into a pre-biased output of up to 1.5V. The output of the EP53F8QI can be pre-biased with a voltage up to 1.5V when the EP53F8QI is first enabled.

### Input and Output Capacitor Selection

Low ESR MLC capacitors with X5R or X7R or equivalent dielectric should be used for input and output capacitors. Y5V or equivalent dielectrics lose too much capacitance with

frequency, DC bias, and temperature. Therefore, they are not suitable for switch-mode DC-DC converter filtering, and must be avoided.

The **input filter capacitor** requirement is a 10 μF, 10V 0805 MLCC capacitor in parallel with a 680pF MLCC capacitor. The 680pF capacitor provides additional high frequency decoupling and is mandatory. The 680pF capacitor must be placed closest to the EP53F8QI as shown in Figure .

The **output filter capacitor** requirement is a 22 μF, 6.3V, 0805 MLCC for most applications. The output ripple can be reduced by using 2 x 22 μF, 6.3V, 0805 MLC capacitors.

Additional bulk capacitance for decoupling and bypass can be placed at the load as long as there is sufficient separation between the  $V_{OUT}$  Sense point and the bulk capacitance.

Excess total capacitance on the output (Output Filter + Bulk) can cause an over-current condition at startup. Refer to the section on Soft-Start for the maximum total capacitance on the output.

### AVIN Decoupling

AVIN should be connected to PVIN using a 10Ω resistor. An 0402 or smaller case size is recommended for this resistor. A 1 μF, 10 V, 0402 MLC capacitor should be connected from AVIN to AGND to provide high frequency decoupling for the control circuitry supply for optimal performance.

### POK Pull Up Resistor Selection

If the POK signal is required for the application. The POK pin must be pulled up through a resistor to any voltage source that can be as high as  $V_{IN}$ . The simplest way is to connect POK to the power input of the converter through a resistor. A 100 kΩ pull up resistor is recommended for most applications for minimal current drain from the voltage source and good noise immunity. POK can sink up to 5mA.

## Layout Recommendation

Figure 7 shows critical components and layer 1 traces of a recommended minimum footprint EP53F8LQI/EP53F8HQI layout with ENABLE tied to  $V_{IN}$ . Alternate ENABLE configurations, and other small signal pins need to be connected and routed according to specific customer application. Please see the Gerber files on the Altera website [www.altera.com/enpirion](http://www.altera.com/enpirion) for exact dimensions and other layers. Please refer to Figure 7 while reading the layout recommendations in this section.

**Recommendation 1:** Input and output filter capacitors should be placed on the same side of the PCB, and as close to the EP53F8QI package as possible. They should be connected to the device with very short and wide traces. Do not use thermal reliefs or spokes when connecting the capacitor pads to the respective nodes. The +V and GND traces between the capacitors and the EP53F8QI should be as close to each other as possible so that the gap between the two nodes is minimized, even under the capacitors.

**Recommendation 2:** Input and output grounds are separated until they connect at the PGND pins. The separation shown on Figure 7 between the input and output GND circuits helps minimize noise coupling between the converter input and output switching loops.

**Recommendation 3:** The system ground plane should be the first layer immediately below the surface layer. This ground plane should be continuous and un-interrupted below the converter and the input/output capacitors. Please see the Gerber files on the Altera website [www.altera.com/enpirion](http://www.altera.com/enpirion).

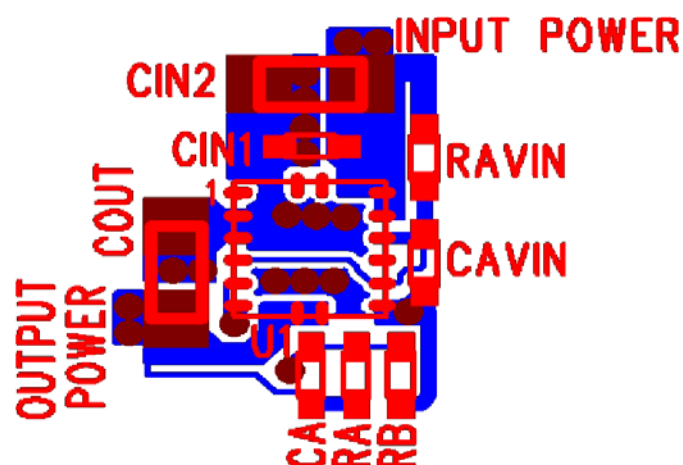

**Figure 7: Top PCB Layer Critical Components and Copper for Minimum Footprint**

**Recommendation 4:** Multiple small vias should be used to connect the ground traces under the device to the system ground plane on another layer for heat dissipation. The drill diameter of the vias should be 0.33mm, and the vias must have at least 1 oz. copper plating on the inside wall, making the finished hole size around 0.20-0.26mm. Do not use thermal reliefs or spokes to connect the vias to the ground plane. It is preferred to put these vias under the capacitors along the edge of the GND copper closest to the +V copper. Please see Figure 7. These vias connect the input/output filter capacitors to the GND plane and help reduce parasitic inductances in the input and output current loops. If the vias cannot be placed under  $C_{IN}$  and  $C_{OUT}$ , then put them just outside the capacitors along the GND. Do not use thermal reliefs or spokes to connect these vias to the ground plane.

**Recommendation 5:** AVIN is the power supply for the internal small-signal control circuits. It should be connected to the input voltage at a quiet point. In Figure 7 this connection is made with RAVIN at the input capacitor close to the  $V_{IN}$  connection.

Recommended PCB Footprint

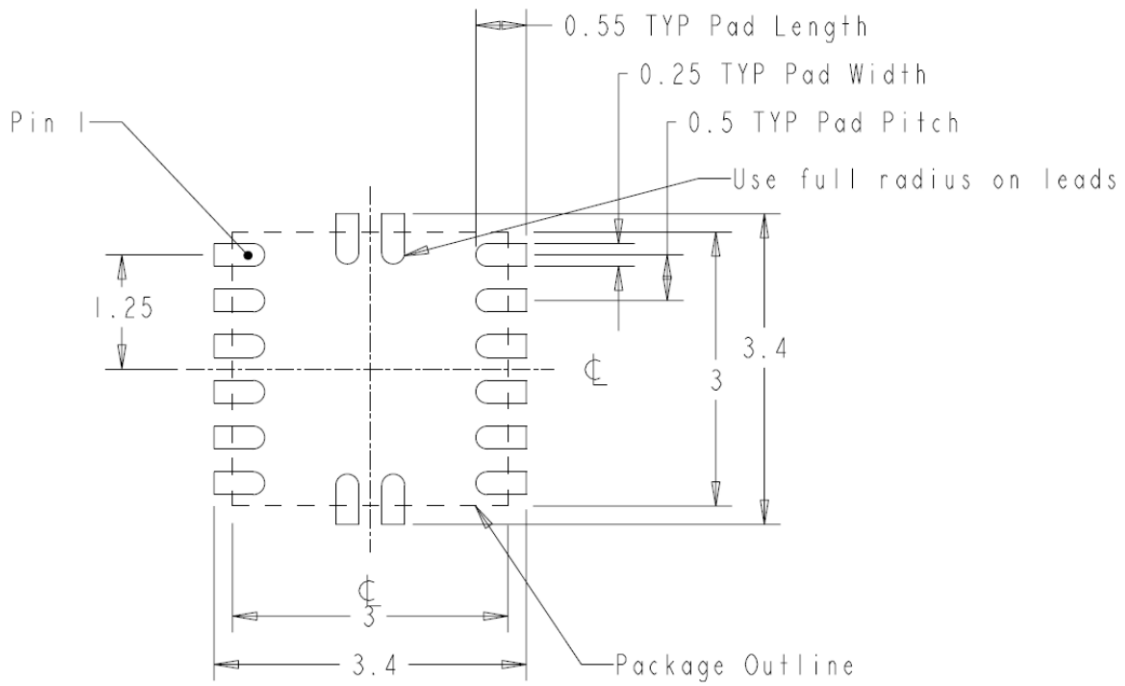

Figure 8: EP53F8QI Package PCB Footprint

Package and Mechanical

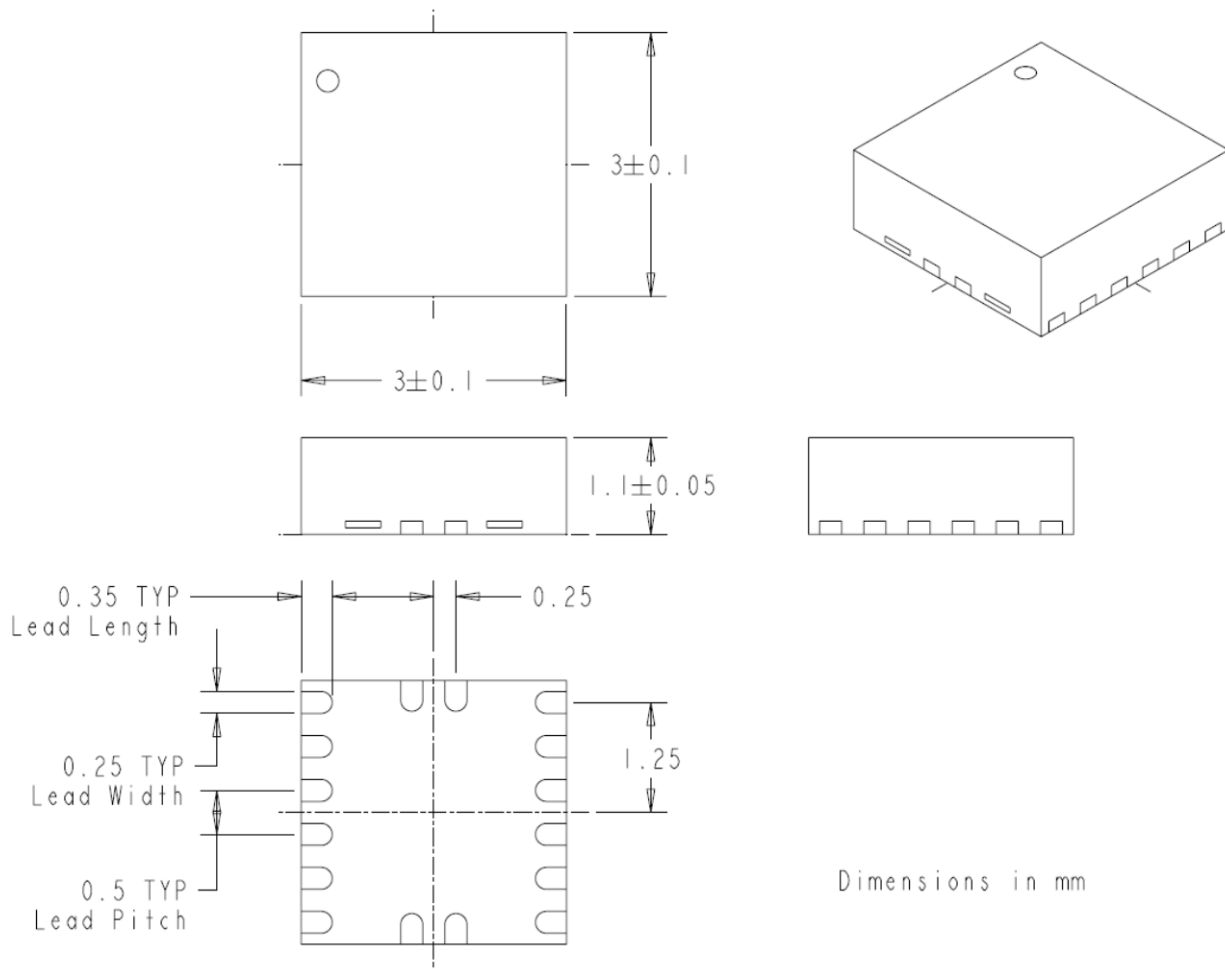

Figure 9: EP53F8QI Package Dimensions

## Revision History

### Change(s) from Datasheet Rev F to Rev G in February 2014

- ENABLE functional description has been rewritten and updated to include delay circuit.....Page 8

### Change(s) from Datasheet Rev G to Rev H in January 2015

- Electrical Characteristic Note to include minimum and maximum ambient temperature.....Page 4

## Contact Information

Altera Corporation  
101 Innovation Drive  
San Jose, CA 95134  
Phone: 408-544-7000  
[www.altera.com](http://www.altera.com)

© 2014 Altera Corporation—Confidential. All rights reserved. ALTERA, ARRIA, CYCLONE, ENPIRION, HARDCOPY, MAX, MEGACORE, NIOS, QUARTUS and STRATIX words and logos are trademarks of Altera Corporation and registered in the U.S. Patent and Trademark Office and in other countries. All other words and logos identified as trademarks or service marks are the property of their respective holders as described at [www.altera.com/common/legal.html](http://www.altera.com/common/legal.html). Altera warrants performance of its semiconductor

products to current specifications in accordance with Altera's standard warranty, but reserves the right to make changes to any products and services at any time without notice. Altera assumes no responsibility or liability arising out of the application or use of any information, product, or service described herein except as expressly agreed to in writing by Altera. Altera customers are advised to obtain the latest version of device specifications before relying on any published information and before placing orders for products or services.

## Looking for pricing, stock, or lifecycle information?

Click below to explore more details on WIN SOURCE:

 [View EVB-EP53F8QI on WIN SOURCE](#)

 [Altera Information](#)

## Optimize Your Supply Chain with WIN SOURCE Solutions

-  Global Sourcing Solution
-  Obsolete Management
-  Cost Control Management
-  Shortage Management
-  Alternative Solution
-  Excess Inventory Management