



**THE DATASHEET OF  
EVB-EN5312QI**



# Enpirion EN5312QI family of DCDC Converter Module Evaluation Board

## Introduction

Thank you for choosing Altera Enpirion power products!

You are evaluating a new class of DCDC converter product, a complete power system on silicon:

- The EN5312QI is a complete module including magnetics and requiring only ceramic input and output capacitors.
- The evaluation board is designed to offer a wide range of engineering evaluation capabilities. This includes the base configuration of a 0805 4.7uF input capacitor and a 0805 10uF output capacitor.
- Pads are available to add up to one additional input capacitor and up to two additional output capacitors to allow for evaluation of performance over a wide range of input/output capacitor combinations.
- Pads are available to populate an external divider if desired.
- Easy jumpers are provided for the following signals:
  - Enable
  - VS0-VS2 output voltage select
- Numerous test points are provided as well as clip leads for input and output connections
- The board comes with input decoupling and reverse polarity protection to protect the device from common setup mishaps.

## Quick Start Guide

Figure 1 shows a top view of the evaluation board.

STEP 1: Set the “ENA” jumper to the Disable Position.

**CAUTION:** the signal pins, ENA, VS0, VS1, and VS2 must be connected to a “high” or a “low”. If left floating the state is indeterminate.

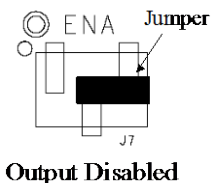

STEP 2: Set the output voltage select pins for the desired output voltage setting. Refer to the section on output voltage select to determine the setting.

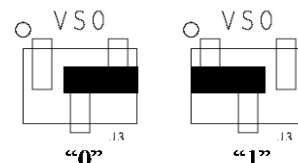

**CAUTION:** the external divider is not populated. Choosing this option will force the device to 100% duty cycle.

STEP 3: Connect Power Supply to the input power connectors, VIN (+) and GND (-) as indicated in Figure 1.

**CAUTION:** be mindful of the polarity. Even though the evaluation board comes with reverse polarity protection diodes, it is rarely a good idea to reverse the input polarity.

STEP 4: Connect the load to the output connectors V<sub>OUT</sub> (+) and GND (-), as indicated in Figure 1.

STEP 5: Power up the board and move the ENA jumper to the enabled position. The EN5312Q is now powered up.

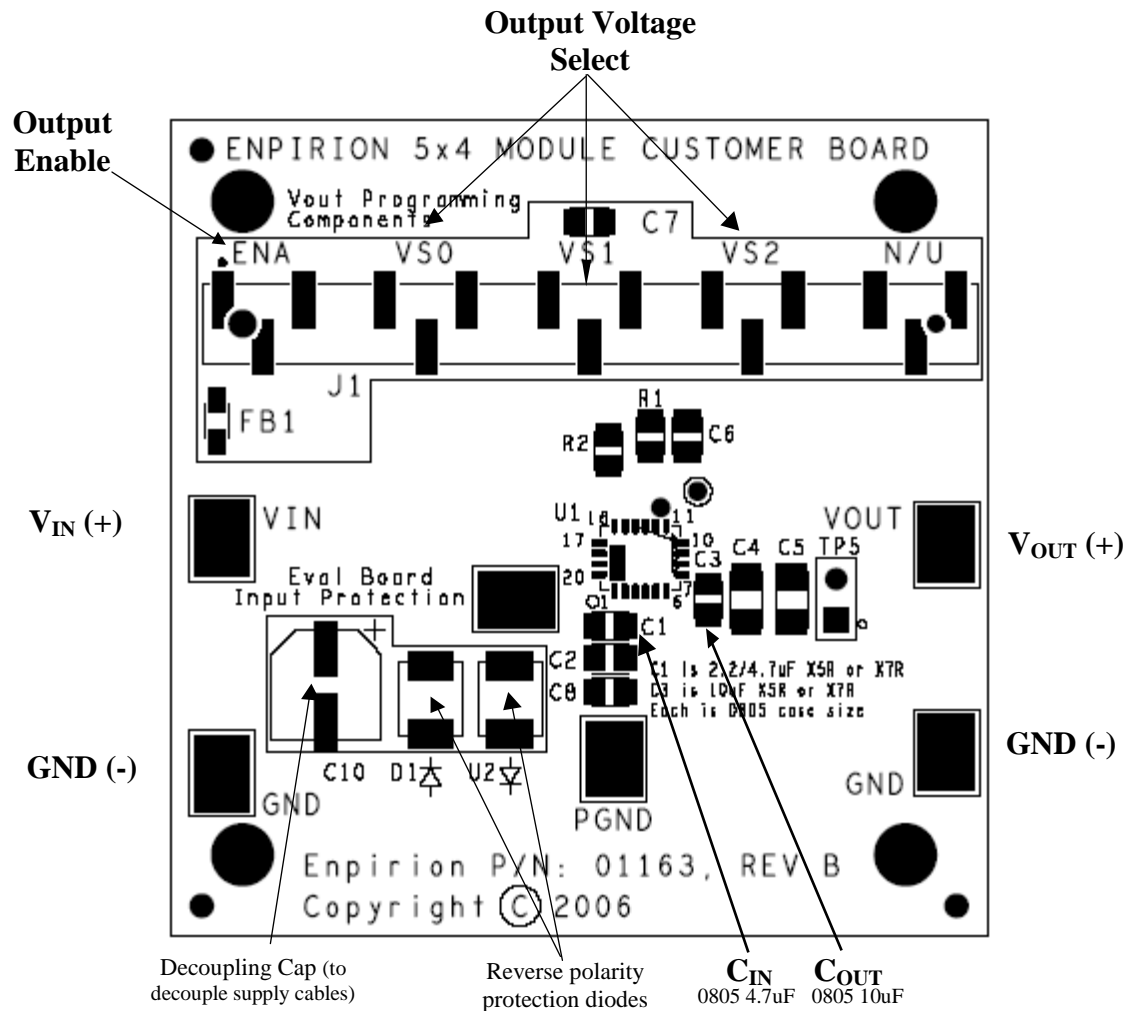

Figure 1. Evaluation Board Layout.

## Output Voltage Select

**Table 1. Output Voltage Select Truth Table**

VS2	VS1	VS0	V <sub>OUT</sub>
0	0	0	3.3V
0	0	1	2.5V
0	1	0	1.8V
0	1	1	1.5V
1	0	0	1.25V
1	0	1	1.2V
1	1	0	0.8V
1	1	1	User Selectable

The EN5312QI utilizes a 3 pin output voltage select scheme. The output voltage is programmed by setting the VSx jumpers to either a logic “1” or a logic “0” as described in the Quick Start section

Table 1 shows the truth table for V<sub>OUT</sub> selection. There are seven preset output voltage levels which can be chosen via the VSx jumpers.

**CAUTION:** the standard evaluation board configuration does not populate the external divider. Selecting the external divider option without populating the external divider will result in unpredictable behavior but can result in the device going into 100% duty cycle and delivering the input rail voltage to the output.

**CAUTION:** All signal pins must be connected to either a logic “1”, jumper to the left, or to a logic “0”, jumper to the right. Leaving the jumper open will result in an indeterminate state.

## Test Recommendations

To guarantee measurement accuracy, the following precautions should be observed:

1. Make all input and output voltage measurements at the board using the test points provided. This will eliminate voltage drop across the line and load cables that can produce false readings.
2. Measure input and output current with series ammeters or accurate shunt resistors. This is especially important when measuring efficiency.
3. Use a balanced impedance probe tip to measure switching signals to avoid noise coupling into the probe ground lead.

## Using The External Voltage Divider

The EN5312Q-E evaluation board is designed to provide a great deal of flexibility in evaluating the performance of the Altera Enpirion DCDC module.

Pre-tinned pads are provided to place 0402 sized 1% resistors on the board to implement an external resistor divider to choose an output voltage other than one of the seven pre-set voltages available on the VID.

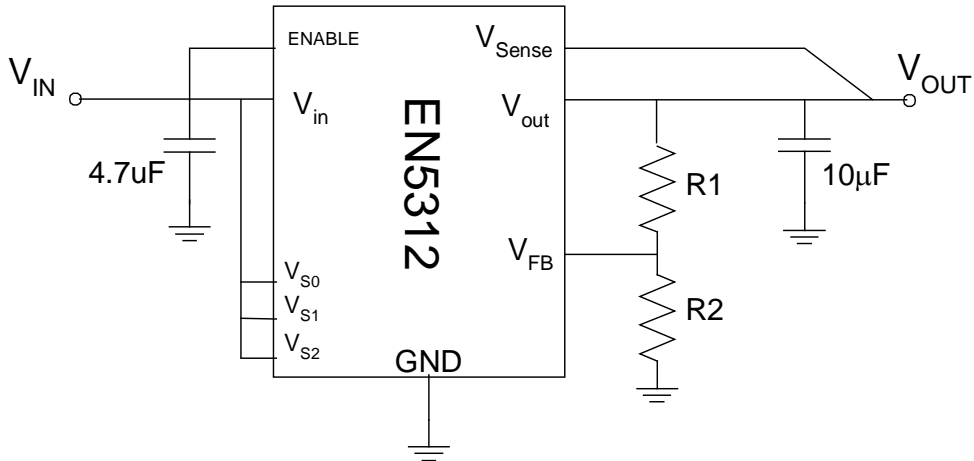

**Figure 2. External divider schematic.**

Figure 3 demonstrates the placement of the R1 and R2 resistors.

The output voltage is selected by the following formula:

$$V_{OUT} = 0.6V \left( 1 + \frac{R1}{R2} \right)$$

R<sub>1</sub> must be chosen as 200KΩ to maintain loop gain. Then R<sub>2</sub> is given as:

$$R_2 = \frac{1.2 \times 10^5}{V_{OUT} - 0.6} \Omega$$

The external voltage divider option is chosen by setting the jumpers VS0, VS1, and VS2 to a logic “high”.

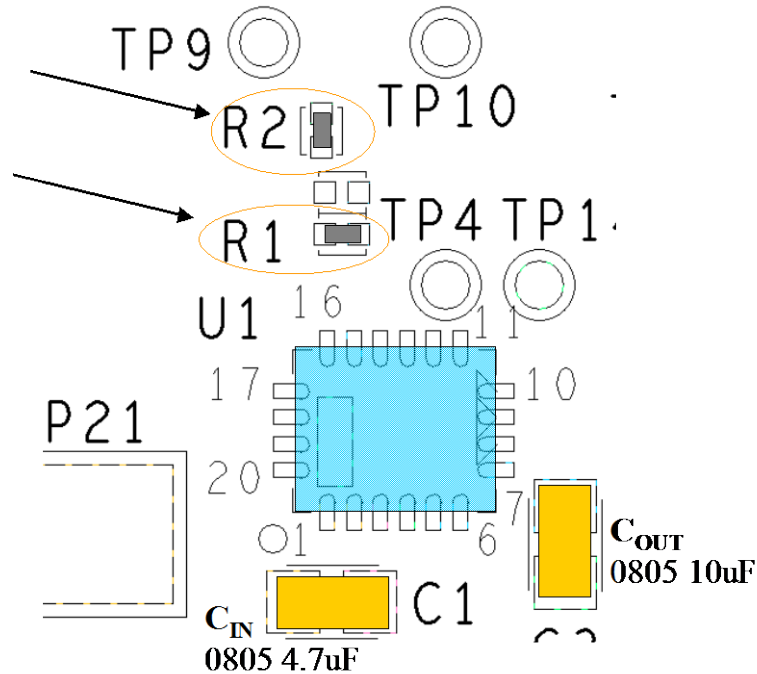

Figure 3. Placement of external divider resistors

## Dynamically Adjustable Output

The EN5312QI is designed to allow for dynamic switching between the predefined voltage levels by toggling the VID pins. The inter-voltage slew rate is optimized to prevent excess undershoot or overshoot as the output voltage levels transition. The slew rate is 1mV/uS.

This feature can be tested by connecting the VSx jumper center pins to logic driver to toggle between the various  $V_{OUT}$  states.

## Input and Output Capacitors

The **input** capacitance requirement is 4.7 uF. Altera recommends that a low ESR MLCC capacitor be used. The EN5312Q-E is populated with a 4.7uF 0805 capacitor. There are pre-tinned pads that allows for additional 0805 capacitors to experiment with input filter performance.

The **output** capacitance requirement is a minimum of 10uF. The control loop is designed to be stable with up to 60uF of total output capacitance. The evaluation board comes populated with a single 10uF 0805 capacitor.

The board has pre-tinned pads for up to 2 additional output capacitors with either 0805 or 1206 footprint.

Capacitance above the 10uF minimum can be added if the transient performance is not sufficient using the 10uF. Altera recommends a low ESR MLCC type capacitor be used.

**NOTE:** Capacitors must be X5R or X7R dielectric formulations.

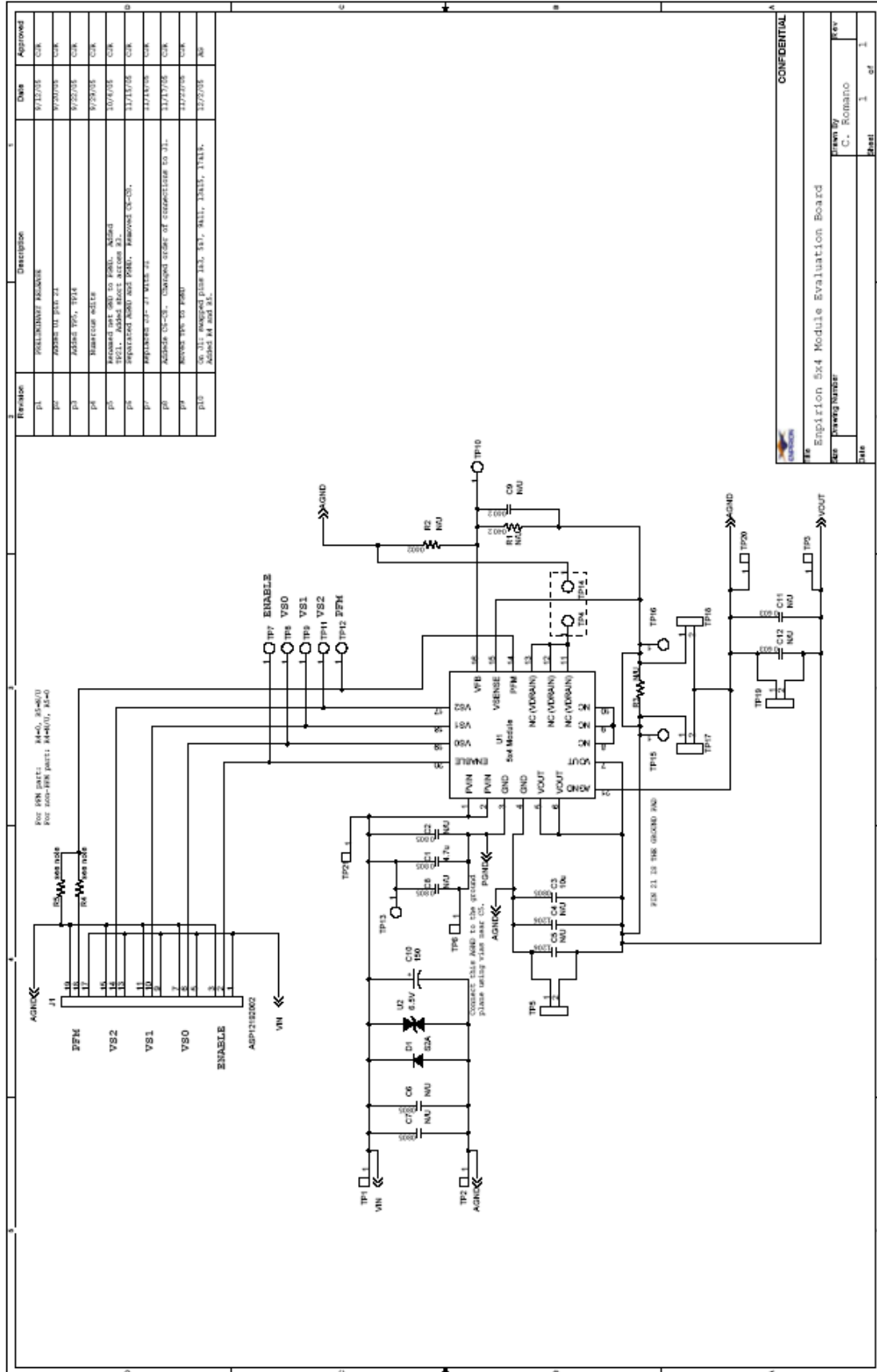

Revision	Description	DWG	Approved
R1	FOLLOW-UP REVISION	9/12/05	CSK
R2	ADDS TO J24-24	9/20/05	CSK
R3	ADDS TP4, TP4	9/22/05	CSK
R4	REWORK W/24	9/23/05	CSK
R5	REWORK W/24 TO PART. ADDS TP11, ADDS BIAS ACTORS R1, R2.	10/4/05	CSK
R6	REWORK W/24 TO PART. ADDS TP12, TP13.	11/17/05	CSK
R7	ADDS TP14, TP15, TP16, TP17, TP18, TP19.	12/22/05	CSK
R8	ADDS TP14, TP15, TP16, TP17, TP18, TP19.	12/22/05	CSK
R9	ADDS TP14, TP15, TP16, TP17, TP18, TP19.	12/22/05	CSK
R10	ADDS TP14, TP15, TP16, TP17, TP18, TP19.	12/22/05	CSK
R11	ADDS TP14, TP15, TP16, TP17, TP18, TP19.	12/22/05	CSK
R12	ADDS TP14, TP15, TP16, TP17, TP18, TP19.	12/22/05	CSK
R13	ADDS TP14, TP15, TP16, TP17, TP18, TP19.	12/22/05	CSK

**CONFIDENTIAL**

Enpirion 5x4 Module Evaluation Board

DESIGNED BY: C. Romano

DATE: 12/22/05

Part: 1 of 1



## Contact Information

Altera Corporation  
101 Innovation Drive  
San Jose, CA 95134  
Phone: 408-544-7000  
<http://www.altera.com>

© 2013 Altera Corporation—Confidential. All rights reserved. ALTERA, ARRIA, CYCLONE, ENPIRION, HARDCOPY, MAX, MEGACORE, NIOS, QUARTUS and STRATIX words and logos are trademarks of Altera Corporation and registered in the U.S. Patent and Trademark Office and in other countries. All other words and logos identified as trademarks or service marks are the property of their respective holders as described at [www.altera.com/common/legal.html](http://www.altera.com/common/legal.html). Altera warrants performance of its semiconductor products to current specifications in accordance with Altera's standard warranty, but reserves the right to make changes to any products and services at any time without notice. Altera assumes no responsibility or liability arising out of the application or use of any information, product, or service described herein except as expressly agreed to in writing by Altera. Altera customers are advised to obtain the latest version of device specifications before relying on any published information and before placing orders for products or services.

## Looking for pricing, stock, or lifecycle information?

Click below to explore more details on WIN SOURCE:

 [View EVB-EN5312QI on WIN SOURCE](#)

 [Altera Information](#)

## Optimize Your Supply Chain with WIN SOURCE Solutions

-  Global Sourcing Solution
-  Obsolete Management
-  Cost Control Management
-  Shortage Management
-  Alternative Solution
-  Excess Inventory Management