



**THE DATASHEET OF
EL7630IWTZ-EVAL**



**NOT RECOMMENDED FOR NEW DESIGNS
RECOMMENDED REPLACEMENT PART
ISL97634**

EL7630

White LED Boost Regulator

FN7371

Rev 1.00

February 22, 2006

The EL7630 represents a high efficiency, constant frequency PWM regulator for use in white LED driving applications. With efficiencies up to 86%, the EL7630 operates at 1.35MHz switching frequency while operating from an input voltage of between 2.7V and 5.5V. The maximum output voltage of 27V enables the EL7630 to drive up to 6 LEDs in series. It is also possible to use the EL7630 to drive LEDs in series/parallel combination for applications requiring up to 15 LEDs.

Available in the 6 Ld SC-70 and the 5 Ld TSOT packages, the EL7630 features the same pinout as competitive products but offers higher efficiency, constant frequency operation. It is specified for operation over the -40°C to +85°C ambient temperature range.

Pinouts

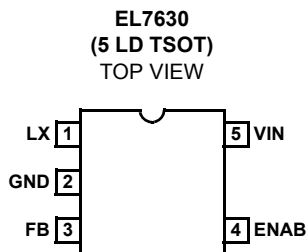
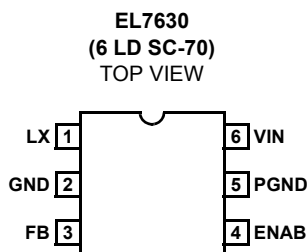

Features

- Up to 6 LEDs in series
- 27V maximum output
- 2.7V to 5.5V input
- Up to 86% efficient
- 1.35MHz constant frequency
- Enable/PWM dimming control
- Pb-free plus anneal available (RoHS compliant)

Applications

- LED backlighting
- Cell phones
- PDAs
- Handheld devices

Ordering Information

PART NUMBER (See Note)	PART MARKING	TAPE & REEL	PACKAGE (Pb-free)	PKG. DWG. #
EL7630ICZ-T7	BCA	7" (3K pcs)	6 Ld SC-70	P6.049
EL7630ICZ-T7A	BCA	7" (250 pcs)	6 Ld SC-70	P6.049
EL7630IWTZ-T7	BAAC	7" (3K pcs)	5 Ld TSOT	MDP0049
EL7630IWTZ-T7A	BAAC	7" (250 pcs)	5 Ld TSOT	MDP0049

NOTE: Intersil Pb-free plus anneal products employ special Pb-free material sets; molding compounds/die attach materials and 100% matte tin plate termination finish, which are RoHS compliant and compatible with both SnPb and Pb-free soldering operations. Intersil Pb-free products are MSL classified at Pb-free peak reflow temperatures that meet or exceed the Pb-free requirements of IPC/JEDEC J STD-020.

Absolute Maximum Ratings ($T_A = 25^\circ\text{C}$)

Input Voltage (V_{IN}) -0.3V to +6V
 LX Voltage -0.3V to +27V
 FB Voltage -0.3V to +6V
 ENAB Voltage -0.3V to +6V
 PGND to GND (SC-70 package) -0.3V to +0.3V

Operating Temperature -40°C to $+85^\circ\text{C}$
 Maximum Junction Temperature $+125^\circ\text{C}$
 Storage Temperature -65°C to $+150^\circ\text{C}$
 Lead Temperature (soldering, 10s) $+300^\circ\text{C}$

CAUTION: Stresses above those listed in "Absolute Maximum Ratings" may cause permanent damage to the device. This is a stress only rating and operation of the device at these or any other conditions above those indicated in the operational sections of this specification is not implied.

IMPORTANT NOTE: All parameters having Min/Max specifications are guaranteed. Typ values are for information purposes only. Unless otherwise noted, all tests are at the specified temperature and are pulsed tests, therefore: $T_J = T_C = T_A$

Electrical Specifications $V_{IN} = 3\text{V}$, $V_{ENAB} = 3\text{V}$, over temperature from -40°C to 85°C unless otherwise specified.

PARAMETER	DESCRIPTION	CONDITION	MIN	TYP	MAX	UNIT
V_{IN-MIN}	Minimum Operating Voltage	$V_{OUT} = 16\text{V}$, $I_{LED} = 20\text{mA}$	2.7			V
V_{IN-MAX}	Maximum Operating Voltage	$V_{OUT} = 25\text{V}$, $I_{LED} = 20\text{mA}$			5.5	V
V_{FB}	Feedback Voltage	$T_A = 25^\circ\text{C}$	86	95	104	mV
			80	95	115	mV
I_{FB}	FB Pin Bias Current				100	nA
I_{IN}	Supply Current	ENAB = 3V, output not switching		0.6	1.0	mA
		ENAB = 0V			1	μA
F_{OSC}	Switching Frequency	$T_A = 25^\circ\text{C}$	0.8	1.35	1.8	MHz
			0.8	1.35	1.9	MHz
D_{MAX}	Maximum Duty Cycle	$T_A = 25^\circ\text{C}$	85	90		%
			82	90		%
I_{LIM}	Switch Current Limit	$T_A = 25^\circ\text{C}$	280	350		mA
			250	350		mA
$r_{DS(ON)}$	Switch On Resistance	$I_{LX} = 100\text{mA}$		750		$\text{m}\Omega$
I_{LEAK}	Switch Leakage Current	$V_{LX} = 27\text{V}$		0.01	1	μA
$V_{ENAB-HI}$	ENAB Voltage High		2.5			V
$V_{ENAB-LO}$	ENAB Voltage Low				0.6	V
I_{ENAB}	ENAB Pin Bias Current				1	μA
$\Delta I_{LED}/\Delta V_{IN}$	Line Regulation	$V_{IN} = 2.7\text{V}$ to 5V		0.2		%/V

Typical Application

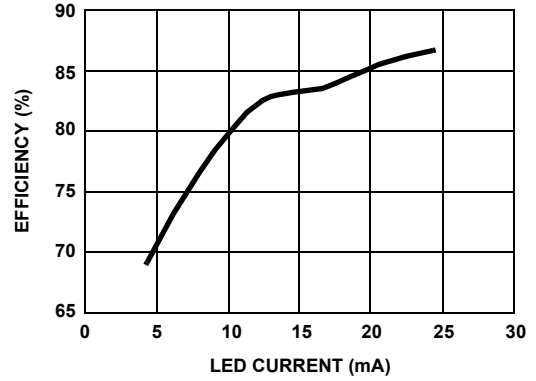
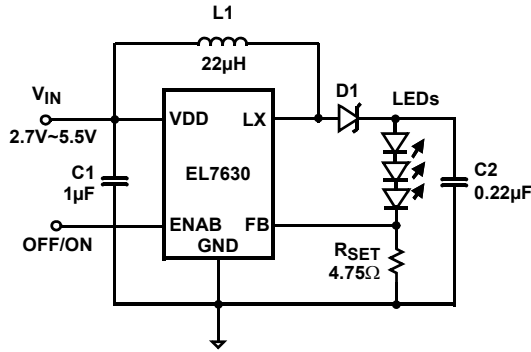

FIGURE 1. TYPICAL APPLICATION CIRCUIT AND EFFICIENCY vs LED CURRENT

Typical Performance Curves

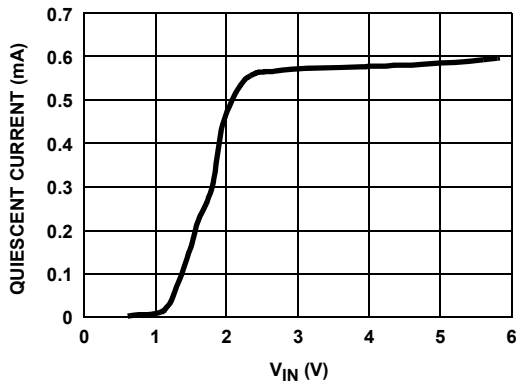

FIGURE 2. QUIESCENT CURRENT (ENABLE)

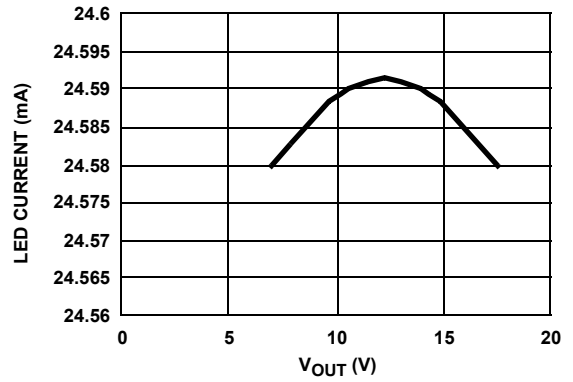

FIGURE 3. LOAD REGULATION (VIN=4V)

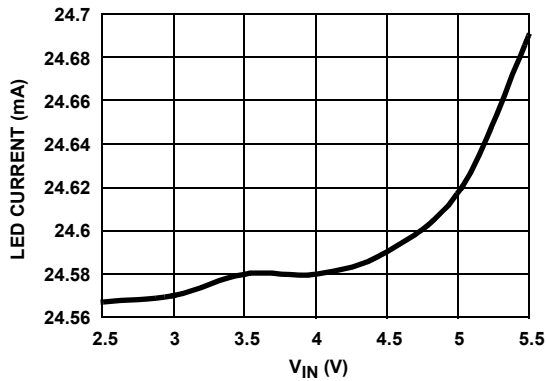

FIGURE 4. LINE REGULATION

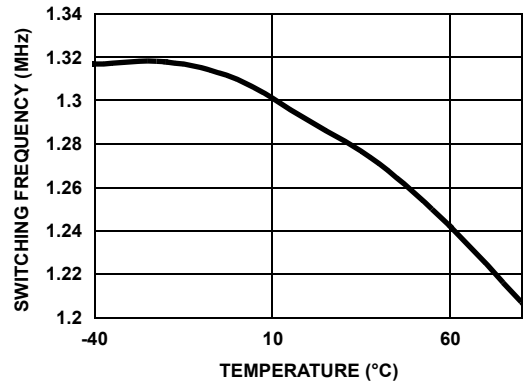

FIGURE 5. SWITCHING FREQUENCY vs TEMPERATURE

Typical Performance Curves

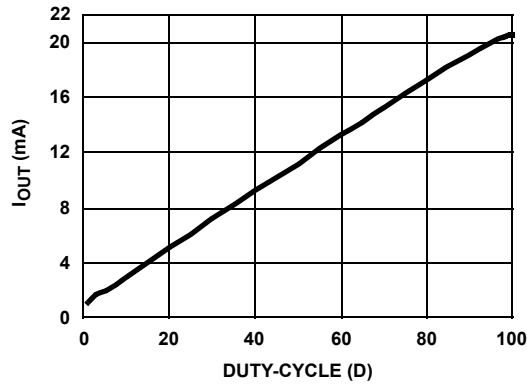

FIGURE 6. PWM DIMMING CURVE (400Hz)

Block Diagram

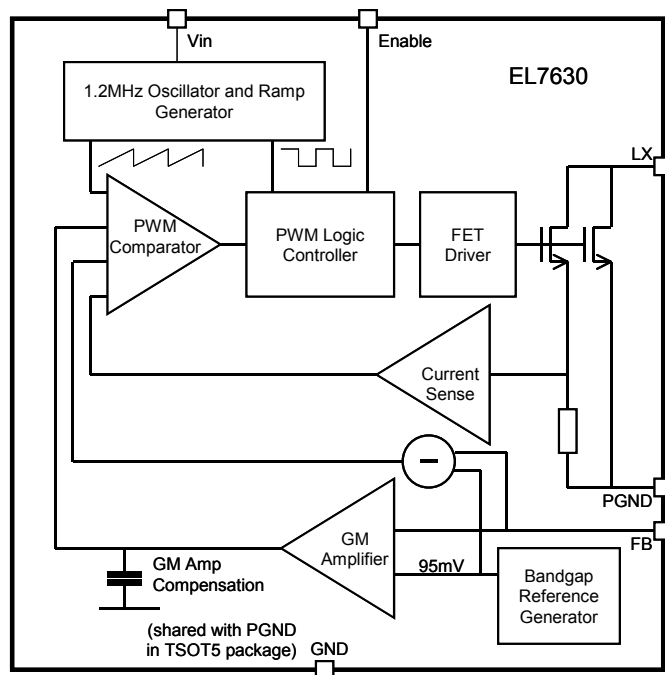

FIGURE 7. EL7630 BLOCK DIAGRAM

Pin Functions

LX (Pin 1) - Switching Pin. Connect to inductor and diode.

GND (Pin 2) - Ground Pin. Connect to local ground.

FB (Pin 3) - Feedback Pin. Connect to the cathode of lowest LED and the sense resistor.

ENAB (Pin 4) - Enable Pin. Connect to enable signal to turn-on or off the device.

PGND (Pin 5, SC-70 Package) - Ground Pin. Connect to Pin 2 and to local ground.

V_{IN} (Pin5/Pin6 SC-70 Package) - Input Supply Pin. Connect to the input supply voltage.

Detailed Description

EL7630 uses a constant frequency, current mode control scheme to provide excellent line and load regulation. It can drive up to 6 LEDs in series or 15 LEDs in parallel/series configuration, with efficiencies of up to 86%. EL7630 operates from an input voltage of 2.7V to 5.5V and can boost up to 27V.

Steady-State Operation

EL7630 operates with constant frequency PWM. The switching frequency is around 1.2MHz. Depending on the input voltage, inductance, number of LEDs and the LED current, the converter operates in either continuous conduction mode or discontinuous conduction mode. Both are normal. The forward current of the LED is set using the R_{SET} resistor. In steady state mode, this current is given by the equation:

$$I_{LED} = \frac{V_{FB}}{R_{SET}} \quad (EQ. 1)$$

Shut-Down

The ENAB pin, when taken low places EL7630 into power down mode. When in power down, the supply current reduced to less than 1µA.

Dimming Control

The ENAB pin also doubles as a brightness control. There are two different types of dimming control methods. The first dimming control is controlled through the duty-cycle of the ENAB input PWM waveform, which can operate at frequencies of 400Hz to 1kHz. The LEDs operate at either zero or full current. This is called PWM dimming control method. The relationship between the average LED current and the duty-cycle (D) of the ENAB pin's waveform is as follows:

$$\text{average } I_{LED} = \frac{V_{FB}}{R_{SET}} \cdot D \quad (EQ. 2)$$

The magnitude of the PWM signal should be higher than the minimum ENAB voltage high. The bench PWM dimming test results are shown in Figure 8. In the test, two PWM frequencies 400Hz and 1kHz are chosen to compare the linear dimming range. It is clear that for lower PWM frequency, the linear dimming range is wider than one for higher PWM frequency. In the PWM dimming test, the output capacitor is 0.22µF.

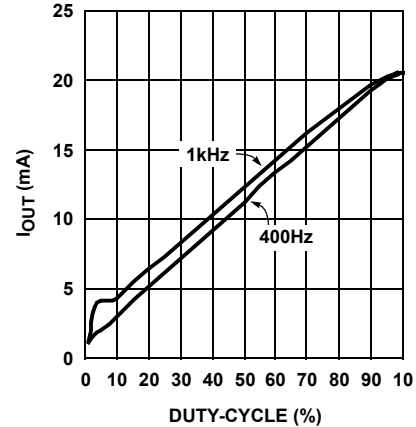

FIGURE 8. PWM DIMMING LINEAR RANGE (FOR 400Hz AND 1kHz PWM FREQUENCIES CONDITION, $C_{OUT} = 0.22\mu F$)

The second dimming control is to apply a variable DC voltage to adjust the LED current. This is called analog dimming control. The dimming control using a DC voltage is shown in Figure 9. As the DC dimming signal voltage increases, the voltage drop on R_1 and R_2 increases and the voltage drop on R_{SET} decreases. Thus, the LED current decreases. The DC dimming signal voltage can be a variable DC voltage or a DC voltage generated from a PWM control signal. For some application areas, the PWM control signal is a high frequency signal. To make dimming controllable with these high frequency PWM signals, the high frequency components of the PWM control signal should be filtered to get the equivalent DC voltage. The equivalent DC voltage is then used as the variable DC voltage for dimming LED current.

$$I_{LED} = \frac{V_{FB}}{R_{SET}} \cdot \frac{R_1 + R_2}{R_2} - \frac{V_{Dim} \cdot R_1}{R_{SET} \cdot R_2} \quad (EQ. 3)$$

$$V_{Dim} = \frac{R_2}{R_1} \cdot V_{FB} \cdot \left(1 + \frac{R_1}{R_2} - F \right) \quad (EQ. 4)$$

where F is the brightness with respect to the undimmed value.

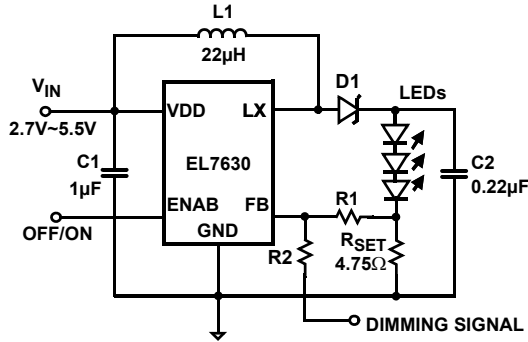

FIGURE 9. ANALOG DIMMING CONTROL APPLICATION CIRCUIT

For a required LED current I_{LED} and chosen values of R_1 and R_2 , the dimming DC voltage V_{Dim} can be expressed as:

$$V_{Dim} = V_{FB} + (V_{FB} - I_{LED} \cdot R_{SET}) \cdot \frac{R_2}{R_1} \quad (EQ. 5)$$

It is clear that as the required LED current I_{LED} is closed to the rate current V_{FB}/R_{SET} , V_{Dim} is closed to V_{FB} . As the required LED current is lower than the rate current, the dimming DC voltage V_{Dim} is increased in R_2/R_1 factor.

Open-Voltage Protection

In some applications, it is possible that the output is opened, e.g. when the LEDs are disconnected from the circuit or the LEDs fail. In this case the feedback voltage will be zero. The EL7630 will then switch to a high duty cycle resulting in a high output voltage, which may cause the LX pin voltage to exceed its maximum 27V rating. To implement overvoltage protection, a zener diode Dz and a resistor R_1 can be used at the output and FB pin to limit the voltage on the LX pin as shown in Figure 10. It is clear that as the zener is turned on, due to the overvoltage, the zener diode’s current will set up a voltage on R_1 and R_{SET} and this voltage is applied on FB pin as the feedback node. This feedback will prevent the output from reaching the overvoltage condition. In the overvoltage protection circuit design, the zener voltage should be larger than the maximum forward voltage of the LED string.

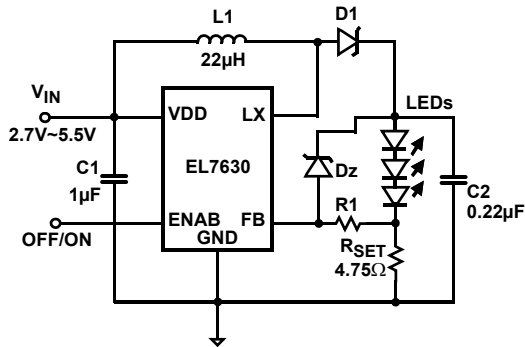

FIGURE 10. LED DRIVER WITH OVERVOLTAGE PROTECTION CIRCUIT

Components Selection

The input capacitance is normally 0.22µF~4.7µF and the output capacitor is 0.22µF~1µF. X5R or X7R type of ceramic capacitor with the correct voltage rating is recommended. The output capacitor value will affect PWM dimming performance. For lower output capacitor values, the range of PWM dimming is wider than for higher values of output capacitor.

When choosing an inductor, make sure the inductor can handle the average and peak currents given by the following formulas (80% efficiency assumed):

$$I_{LAVG} = \frac{I_{LED} \cdot V_{OUT}}{0.8 \cdot V_{IN}} \quad (EQ. 6)$$

$$I_{LPK} = I_{LAVG} + \frac{1}{2} \cdot \Delta I_L \quad (EQ. 7)$$

$$\Delta I_L = \frac{V_{IN} \cdot (V_{OUT} - V_{IN})}{L \cdot V_{OUT} \cdot f_{OSC}} \quad (EQ. 8)$$

Where:

- ΔI_L is the peak-to-peak inductor current ripple in Ampere
- L inductance in H.
- f_{OSC} switching frequency, typically 1.2MHz

The boost inductor can be chosen in a wide range of inductance (10µH~82µH). For 10µH inductor value, the boost inductor current will be in discontinuous mode. As the inductor value decreases further, the ripple of the boost inductor current is increased and can even trigger overcurrent protection. For high boost inductor value, the boost inductor current will be in continuous mode. For general boost converter, as the converter operates in continuous mode, there is right half plane zero (RHPZ). If RHPZ frequency is less than or close to the control loop crossover frequency, there is a stability issue. In EL7630, the compensation network is well designed and there is no RHPZ stability issue even if the inductor value is over 82µH. For the same series of inductors, a lower inductance has lower DC resistance (DCR), which causes less conducting loss, but higher peak to peak current variation, which generates more RMS current loss. Figure 11 shows the efficiency of the demo board with different LED load for a specific series of inductor.

The diode used should be a schottky type with minimum reverse voltage of 28V. The diode’s peak current is the same as the inductor’s peak current. The schottky RMS current is:

$$I_{RMS} = \sqrt{D \cdot (2 \cdot I_{LAVG}^2 + \frac{1}{6} \cdot \Delta I_L^2)} \quad (EQ. 9)$$

The efficiency bench test results are shown in Figure 11. In the test, the input voltage is 4V and 2, 3, 4, 5 and 6 LEDs are used as the load (boost inductor L = 22µH Sumida CDRH5D28R-220NC).

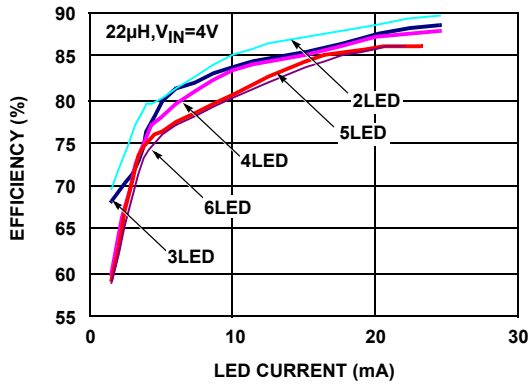

FIGURE 11. EFFICIENCY CURVE WITH 2, 3, 4, 5 AND 6 LEDs LOAD

White LED Connections

One leg of LEDs connected in series will ensure brightness uniformity. The 27V maximum output voltage specification enables up to 6 LEDs to be placed in series.

In order to output more power to drive more LEDs, LEDs should be in series/parallel connection. Due to the LED's negative temperature coefficient, in each parallel branch, the driving source should be high impedance, to balance the LED current in each branch. One of the ways to ensure the brightness uniformity is to add mirror current balance circuit, built up with three transistors for the 15 LEDs series/parallel connection application shown in Figure 12.

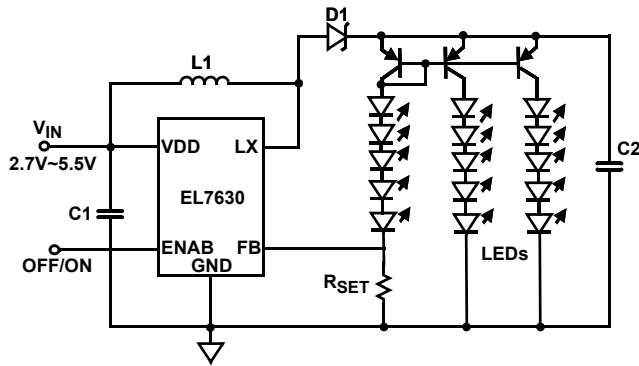

FIGURE 12. LEDs IN SERIES/PARALLEL WITH MIRROR CURRENT BALANCE

PCB Layout Considerations

The PCB layout is very important for the converter to function properly. For the SC-70 6 pin package, Power Ground and Signal Ground should be separated to ensure the high pulse current in the power ground does not interfere with the sensitive signals connected to Signal Ground. Both grounds should only be connected at one point right at the chip. The heavy current loops (V_{IN} -L1-LX-PGND, and V_{IN} -L1-D1-C2-PGND) should be as short as possible. For the TSOT 5 pin package, there is no separated GND. All return GNDs should be connected in GND pin but with no sharing branch. Based on the signal level on each branch, the lower power level of the branch, the closer the branch to GND pin in order to minimize the branch interactive.

The FB pin is most important. The current sense resistor R_{SET} should be very close to this pin. If a long trace is required to the LEDs, a small decoupling capacitor should be placed at this pin.

The heat of the IC is mainly dissipated through the PGND pin. Maximizing the copper area connected to this pin is preferable. In addition, a solid ground plane is always helpful for the EMI performance.

The demo board is a good example of layout based on the principle. Please refer to the EL7630 Application Brief for the layout.

© Copyright Intersil Americas LLC 2005-2006. All Rights Reserved.
 All trademarks and registered trademarks are the property of their respective owners.

For additional products, see www.intersil.com/en/products.html

Intersil products are manufactured, assembled and tested utilizing ISO9001 quality systems as noted in the quality certifications found at www.intersil.com/en/support/qualandreliability.html

Intersil products are sold by description only. Intersil may modify the circuit design and/or specifications of products at any time without notice, provided that such modification does not, in Intersil's sole judgment, affect the form, fit or function of the product. Accordingly, the reader is cautioned to verify that datasheets are current before placing orders. Information furnished by Intersil is believed to be accurate and reliable. However, no responsibility is assumed by Intersil or its subsidiaries for its use; nor for any infringements of patents or other rights of third parties which may result from its use. No license is granted by implication or otherwise under any patent or patent rights of Intersil or its subsidiaries.

For information regarding Intersil Corporation and its products, see www.intersil.com

Looking for pricing, stock, or lifecycle information?

Click below to explore more details on WIN SOURCE:

 [View EL7630IWTZ-EVAL on WIN SOURCE](#)

 [Intersil Information](#)

Optimize Your Supply Chain with WIN SOURCE Solutions

-  Global Sourcing Solution
-  Obsolete Management
-  Cost Control Management
-  Shortage Management
-  Alternative Solution
-  Excess Inventory Management