



# dsPIC33FJ06GS001/101A/102A/202A and dsPIC33FJ09GS302

## dsPIC33FJ06GS001/101A/102A/202A and dsPIC33FJ09GS302 Family Silicon Errata and Data Sheet Clarification

The dsPIC33FJ06GS001/101A/102A/202A and dsPIC33FJ09GS302 family devices that you have received conform functionally to the current Device Data Sheet (DS75018C), except for the anomalies described in this document.

The silicon issues discussed in the following pages are for silicon revisions with the Device and Revision IDs listed in [Table 1](#). The silicon issues are summarized in [Table 2](#).

The errata described in this document will be addressed in future revisions of the dsPIC33FJ06GS001/101A/102A/202A and dsPIC33FJ09GS302 silicon.

**Note:** This document summarizes all silicon errata issues from all revisions of silicon, previous as well as current. Only the issues indicated in the last column of [Table 2](#) apply to the current silicon revision (A1).

Data Sheet clarifications and corrections start on [Page 13](#), following the discussion of silicon issues.

The silicon revision level can be identified using the current version of MPLAB® IDE and Microchip's programmers, debuggers and emulation tools, which are available at the Microchip corporate web site ([www.microchip.com](http://www.microchip.com)).

For example, to identify the silicon revision level using MPLAB IDE in conjunction with MPLAB ICD 3 or PICKit™ 3:

1. Using the appropriate interface, connect the device to the MPLAB ICD 3 programmer/debugger or PICKit 3.
2. From the main menu in MPLAB IDE, select *Configure>Select Device*, and then select the target part number in the dialog box.
3. Select the MPLAB hardware tool (*Debugger>Select Tool*).
4. Perform a "Connect" operation to the device (*Debugger>Connect*). Depending on the development tool used, the part number and Device Revision ID value appear in the **Output** window.

**Note:** If you are unable to extract the silicon revision level, please contact your local Microchip sales office for assistance.

The Device and Revision ID values for the various dsPIC33FJ06GS001/101A/102A/202A and dsPIC33FJ09GS302 silicon revisions are shown in [Table 1](#).

**TABLE 1: SILICON DEVREV VALUES**

Part Number	Device ID <sup>(1)</sup>	Revision ID for Silicon Revision <sup>(2)</sup>
		A1
dsPIC33FJ06GS001	0x4900	0x3001
dsPIC33FJ06GS101A	0x4901	
dsPIC33FJ06GS102A	0x4904	
dsPIC33FJ06GS202A	0x4905	
dsPIC33FJ09GS302	0x4906	

- Note 1:** The Device and Revision IDs (DEVID and DEVREV) are located at the last two implemented addresses in program memory.
- 2:** Refer to the "dsPIC33F Flash Programming Specification for Devices with Volatile Configuration Bits" (DS70659) for detailed information on Device and Revision IDs for your specific device.

# dsPIC33FJ06GS001/101A/102A/202A and dsPIC33FJ09GS302

**TABLE 2: SILICON ISSUE SUMMARY**

Module	Feature	Item #	Issue Summary	Affected Revisions <sup>(1)</sup>
				A1
CPU	Instruction Set	1.	When using the <code>div.sd</code> instruction, the overflow bit is not getting set when an overflow occurs.	X
CPU	Interrupt Disable	2.	When a previous <code>DISI</code> instruction is active (i.e., the <code>DISICNT</code> register is non-zero), and the value of the <code>DISICNT</code> register is updated manually, the <code>DISICNT</code> register freezes and disables interrupts permanently.	X
PWM	PWM Module Enable	3.	A glitch may be observed on the PWM pins when the PWM module is enabled after assignment of pin ownership to the PWM module.	X
PWM	Master Time Base Mode	4.	Writing to the Period register, and any other timing parameter of the PWM module, will cause the update of the other timing parameter to take effect, one PWM cycle after the period update is effective.	X
PWM	PWM Module Enable	5.	If the PWM Clock Divider Select Register, <code>PTCON2</code> , is not equal to zero, the PWM module may or may not initialize from an override state	X
CPU	Sleep Mode	6.	When the <code>VREGS</code> bit ( <code>RCON&lt;8&gt;</code> ) is set to a logic '0', and the device enters into Sleep mode, the device cannot wake-up.	X
SPI	Frame Sync	7.	In Framed Master mode and the Frame Sync Pulse Edge Select bit ( <code>FRMDLY</code> ) is set to '1', transmitting a word and then buffering another word in the <code>SPIxBUF</code> register, before the transmission has completed, results in an incomplete transmission of the first data word.	X
SPI	Frame Sync	8.	In SPI Slave mode, with the Frame Sync pulse set as an input, <code>FRMDLY</code> must be set to '0'.	X
UART	TX Interrupt	9.	A Transmit (TX) Interrupt may occur before the data transmission is complete.	X
UART	UARTEN	10.	The Transmitter Write Pointer does not get cleared when the UART is disabled ( <code>UARTEN = 0</code> ); it requires <code>TXEN</code> to be set in order to clear the Write Pointer.	X
Comparator	Comparator Output	11.	A glitch may occur on the comparator output when the comparator module is enabled ( <code>CMPON = 1</code> ).	X
Comparator	External Reference	12.	Comparator and <code>DACOUT</code> do not function when <code>EXTREF</code> is enabled and <code>EXTREF</code> input voltage is less than 1.6V.	X
PWM	Immediate Update	13.	Dead time is not asserted when <code>PDCx</code> is updated to cause an immediate transition on the <code>PWMxH</code> and <code>PWMxL</code> outputs.	X
PWM	Center-Aligned Mode	14.	<code>PWMxH</code> is asserted for 100% of the PWM period in Complementary mode under certain circumstances.	X
Comparator	Filter	15.	The digital filter does not function per design specification.	X
PWM	Current Reset Mode	16.	In Current Reset mode, the PWM Reset only happens in every alternate PWM cycle.	X
PWM	External Period Reset Mode	17.	PWM period is reset if the External Period Reset signal is still asserted at the end of the PWM on time.	X

**Note 1:** Only those issues indicated in the last column apply to the current silicon revision.

# dsPIC33FJ06GS001/101A/102A/202A and dsPIC33FJ09GS302

**TABLE 2: SILICON ISSUE SUMMARY (CONTINUED)**

Module	Feature	Item #	Issue Summary	Affected Revisions <sup>(1)</sup>
				A1
PWM	Dead Time	18.	DTRx and ALTDTRx have no affect when PWM module is configured in Push/Pull Output mode (PMOD<1:0> (IOCONx<11:10>) = 0b10).	X
PWM	Master Time Base Mode	19.	When IUE (PWMCONx<0>) = 0, specific changes to the PHASEx register may result in missing dead time.	X
PWM	PWMCAPx	20.	The Primary PWMx Time Base Capture register (PWMCAPx) only works when the Current-Limit Interrupt bit is enabled (CLIEN (PWMCONx<11>) = 1).	X
PWM	Redundant/ Push-Pull Output Mode	21.	Changing the duty cycle value from a non-zero value to zero will produce a glitch pulse equal to 1 PWM clock.	X
PWM	Push-Pull Mode	22.	Period register writes may produce back-to-back pulses under certain conditions.	X

**Note 1:** Only those issues indicated in the last column apply to the current silicon revision.

## Silicon Errata Issues

**Note:** This document summarizes all silicon errata issues from all revisions of silicon, previous as well as current. Only the issues indicated by the shaded column in the following tables apply to the current silicon revision (**A1**).

### 1. Module: CPU

When using the Signed 32-by-16-bit Division instruction, `div.sd`, the overflow bit does not always become set when an overflow occurs.

#### Work around

Test for and handle overflow conditions outside of the `div.sd` instruction.

#### Affected Silicon Revisions

A1							
X							

### 2. Module: CPU

When a previous `DISI` instruction is active (i.e., the `DISICNT` register is non-zero), and the value of the `DISICNT` register is updated manually, the `DISICNT` register freezes and disables interrupts permanently.

#### Work around

Avoid updating the `DISICNT` register manually. Instead, use the `DISI #n` instruction with the required value for 'n'.

#### Affected Silicon Revisions

A1							
X							

### 3. Module: PWM

The PENH and PENL bits in the IOCONx register are used to assign ownership of the pins to either the PWM module or the GPIO module. The correct procedure to configure the PWM module is to first assign pin ownership to the PWM module and then enabling it using the PTEN bit in the PTCN register.

If the PWM module is enabled using the above sequence, then a glitch may be observed on the PWM pins before actual switching of the PWM outputs begins. This glitch may cause the momentary turn-on of power MOSFETs that are driven by the PWM pins and may cause damage to the application hardware.

#### Work around

Perform the following steps to avoid any glitches from appearing on the PWM outputs at the time of enabling:

1. Configure the respective PWM pins to digital inputs using the TRISx registers. This step will put the PWM pins in a high-impedance state. The PWM outputs must be maintained in a safe state by using pull-up or pull-down resistors.

2. Assign pin ownership to the GPIO module by configuring the PENH bit (IOCONx<15>) = 0 and the PENL bit (IOCONx<14>) = 0.
3. Specify the PWM override state to the desired safe state for the PWM pins using the OVRDAT<1:0> bit field in the IOCONx register.
4. Override the PWM outputs by setting the OVRENH bit (IOCONx<9>) = 1 and the OVRENL bit (IOCONx<8>) = 1.
5. Enable the PWM module by setting the PTEN bit (PTCN<15>) = 1.
6. Remove the PWM overrides by making the OVRENH bit (IOCONx<9>) = 0 and the OVRENL bit (IOCONx<8>) = 0.
7. Ensure a delay of at least one full PWM cycle.
8. Assign pin ownership to the PWM module by setting the PENH bit (IOCONx<15>) = 1 and the PENL bit (IOCONx<14>) = 1.

The code in [Example 1](#) illustrates the use of this work around.

#### Affected Silicon Revisions

A1							
X							

### EXAMPLE 1: CONFIGURE PWM MODULE TO PREVENT GLITCHES ON PWM1H AND PWM1L PINS AT THE TIME OF ENABLING

```

TRISAbits.TRISA4 = 1;    // Configure PWM1H/RA4 as digital input
                        // Ensure output is in safe state using pull-up or pull-down resistors
TRISAbits.TRISA3 = 1;    // Configure PWM1L/RA3 as digital input
                        // Ensure output is in safe state using pull-up or pull-down resistors

IOCON1bits.PENH = 0;    // Assign pin ownership of PWM1H/RA4 to GPIO module
IOCON1bits.PENL = 0;    // Assign pin ownership of PWM1L/RA3 to GPIO module

IOCON1bits.OVRDAT = 0;  // Configure PWM outputs override state to the desired safe state

IOCON1bits.OVRENH = 1;  // Override PWM1H output
IOCON1bits.OVRENL = 1;  // Override PWM1L output

PTCONbits.PTEN = 1;    // Enable PWM module

IOCON1bits.OVRENH = 0;  // Remove override for PWM1H output
IOCON1bits.OVRENL = 0;  // Remove override for PWM1L output

Delay(x);              // Introduce a delay greater than one full PWM cycle

IOCON1bits.PENH = 1;    // Assign pin ownership of PWM1H/RA4 to PWM module
IOCON1bits.PENL = 1;    // Assign pin ownership of PWM1L/RA3 to PWM module
    
```

## 4. Module: PWM

The high-speed PWM module can operate with variable period, duty cycle, dead-time and phase values. The master period and other timing parameters can be updated in the same PWM cycle. With immediate updates disabled, the new values should take effect at the start of the next PWM cycle.

As a result of this erratum, the updated master period takes effect on the next PWM cycle, while the update of the additional timing parameter is delayed by one PWM cycle. The parameters affected by this erratum are as follows:

Master Period Registers: Update effective on the next PWM cycle:

- PTPER: If PWMCONx<MTBS> = 0
- STPER: If PWMCONx<MTBS> = 1

Additional PWM Timing Parameters: Update effective one PWM cycle after master period update:

- Duty Cycle: PDCx, SDCx and MDC registers
- Phase: PHASEx or SPHASEx registers
- Dead Time: DTRx and ALTDTRx registers and dead-time compensation signals
- Clearing of current-limit and Fault conditions, and application of External Period Reset signal

### Work around

If the application requires the master period and other parameters to be updated at the same time, enable both immediate updates:

- PTCON<EIPU> = 1 to enable immediate period updates
- PWMCONx<IUE> = 1 to enable immediate updates of additional parameters listed above

Enabling immediate updates will allow updates to the master period and the other parameter to take effect immediately after writing to the respective registers.

### Affected Silicon Revisions

A1								
X								

## 5. Module: PWM

If the PWM Clock Divider Select register (PTCON2) is not equal to zero, the PWM module may or may not initialize from an override state, even when the Override Enable bits are set (OVRENH = 1 or OVRENL = 1).

### Work around

When configuring the Override Enable bits, OVRENH and OVRENL (IOCONx<9,8>), set these bits implicitly using word format; do not set them explicitly using bit format.

That is, use this format:

```
IOCON1 = IOCON1 & 0xFCFF
```

and not this format:

```
IOCON1bits.OVRENH = 1
```

### Affected Silicon Revisions

A1							
X							

## 6. Module: CPU

When the VREGS bit (RCON<8>) is set to a logic '0' and the device enters Sleep mode, the device cannot wake up.

### Work around

Ensure that the VREGS bit (RCON<8>) is set to a logic '1' for device Sleep mode operation.

### Affected Silicon Revisions

A1							
X							

## 7. Module: SPI

When the SPI module is configured in Framed Master mode and the Frame Sync Pulse Edge Select bit (FRMDLY) is set to '1', transmitting a word and then buffering another word in the SPIxBUF register, before the transmission has completed, results in an incomplete transmission of the first data word. Only the first 15 bits from the first data word are transmitted, followed by the Sync Pulse and the complete second word.

### Work around

Between the two back-to-back SPI operations, add a delay to ensure that the first word is fully transmitted before the second word is written to the SPIxBUF register, as shown in [Example 2](#).

### EXAMPLE 2:

```
SPI1BUF = 0x0001;

while (SPI1STATbits.SPITBF);

    asm("REPEAT #50");.
    asm("NOP");

// The number of NOPs depends on the SPI
// clock prescalers

SPI1BUF = 0x0002;
```

### Affected Silicon Revisions

A1								
X								

## 8. Module: SPI

When in SPI Slave mode (SPIxCON1<MSTEN> = 0) and using the Frame Sync Pulse output feature (SPIxCON2<FRMEN> = 1) in Slave mode (SPIxCON2<SPIFSD> = 0), the Frame Sync Pulse Edge Select bit must be set to '0' (SPIxCON2 <FRMDLY> = 0).

### Work around

There is no work around. The Frame Sync Pulse Edge Select bit cannot be set to produce a Frame Sync Pulse that coincides with the first bit clock.

### Affected Silicon Revisions

A1								
X								

## 9. Module: UART

When using UTXISEL<1:0> = 01 (interrupt when last character is shifted out of the Transmit Shift Register) and the final character is being shifted out through the Transmit Shift Register, the Transmit (TX) Interrupt may occur before the final bit is shifted out.

### Work around

If it is critical that the interrupt processing occur only when all transmit operations are complete, hold off the interrupt routine processing by adding a loop at the beginning of the routine that polls the Transmit Shift Register Empty bit (TRMT) before processing the rest of the interrupt.

### Affected Silicon Revisions

A1								
X								

## 10. Module: UART

The Transmitter Write Pointer does not get cleared when the UART module is disabled (UARTEN = 0), and it requires the TXEN bit to be set in order to clear the Write Pointer.

### Work around

Do not load data into the TX FIFO (register) before setting the TXEN bit.

### Affected Silicon Revisions

A1								
X								

## 11. Module: Comparator

When the Comparator module is enabled (CMPON = 1), the output of the comparator is set high for approximately 300 ns, regardless of the comparator input signal level.

### Work around

Allow at least 1 µs after the Comparator module is enabled (CMPON = 1) to initiate any comparator driven interrupts or Faults.

### Affected Silicon Revisions

A1								
X								

## 12. Module: Comparator

The comparator and DAC modules do not function when both of the following are true:

- the External Voltage Reference is selected (EXTREF = 1), and
- the external voltage reference is less than 1.6V.

### **Work around**

Use the INTREF or AVDD/2 references, whenever possible.

If the External Voltage Reference must be used, be aware that the published specifications for EXTREF define an input voltage range of 0V minimum and (AVDD – 1.6)V maximum. For the affected silicon revisions, the operational input voltage limits of EXTREF are 1.6V minimum and (AVDD – 0.6)V maximum.

### **Affected Silicon Revisions**

A1							
X							

## 13. Module: PWM

The PWMx generator may not assert dead time on the edges of transitions. This has been observed when all of the following conditions are present:

- The PWMx generator is configured to operate in Complementary mode with the independent time base or master time base;
- Immediate update is enabled; and
- The value in the PDCx register is updated in such a manner that the PWMxH and PWMxL outputs make an immediate transition.

The current duty cycle, PDCOLD, newly calculated duty cycle, PDCNEW, and the point at which the write to the Duty Cycle register occurs within the PWMx time base, will determine if the PWMxH and PWMxL outputs make an immediate transition. PWMxH and PWMxL outputs make an immediate transition if the Duty Cycle register is written with a new value, PDCNEW, at a point of time when the PWMx time base is counting a value that is in between PDCNEW and PDCOLD. Additionally, writing to the Duty Cycle register close to the instant of time where dead time is being applied may result in reduced dead time, effective on the PWMxH and PWMxL transition edges.

In [Figure 1](#) (following page), if the duty cycle write occurred in the shaded box, then PWMxH and PWMxL will make an immediate transition without dead time.

### **Work around**

None. However, in most applications the duty cycle update timing can be controlled using the TRIGx trigger or Special Event Trigger such that the above mentioned conditions are avoided altogether.

### **Affected Silicon Revisions**

A1							
X							

FIGURE 1: TIMING DIAGRAMS FOR CENTER-ALIGNED AND EDGE-ALIGNED MODES

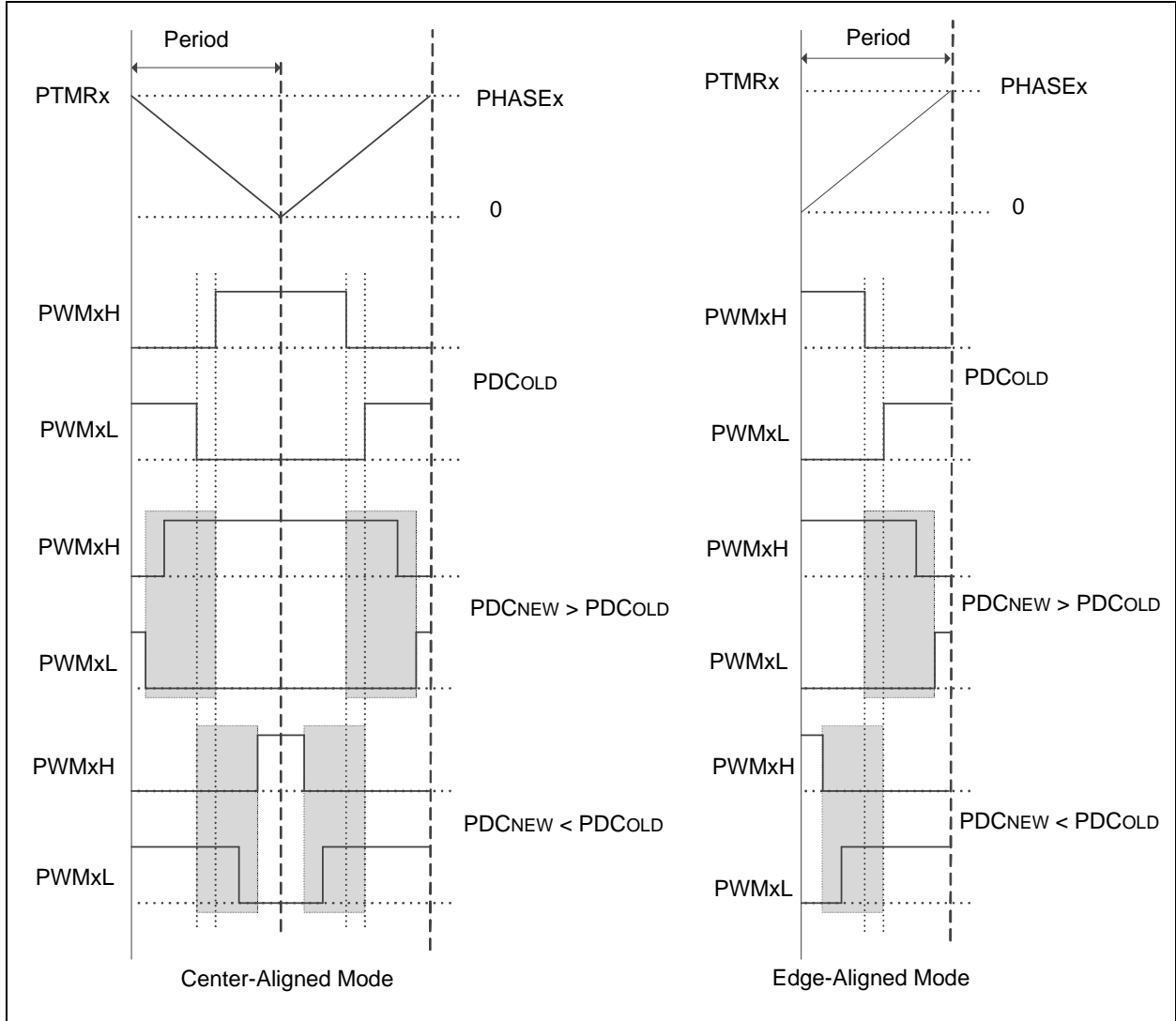

## 14. Module: PWM

In Center-Aligned Complementary mode with independent time base, the PWM generator may assert the PWMxH output for 100% of the duty cycle. This has been observed when the value in its PDCx register is less than one-half the value in its ALTDTRx register.

### Work around

Include a software routine to check that the duty cycle value written to the PDCx register is always at least one-half of the value in ALTDTRx.

**Example 3** shows one way of doing this, with PDCtemp representing the value to be written to the PDCx register.

### EXAMPLE 3:

```

Altdtr_by2 = ALTDTRx / 2;
if (PDCtemp < Altdtr_by2)
{
    PDCx = Altdtr_by2;
}
else
{
    PDCx = PDCtemp;
}
    
```

### Affected Silicon Revisions

A1								
X								

## 15. Module: Comparator

The Digital Filter does not function per design specification. When the FLTREN bit (CMPCON<10>) is enabled, it will generate a delay of approximately three cycles of the selected clock source. This results in unwanted comparator latency delay before changing the state of the comparator output and any of the interrupts driven by it.

### Work around

The FLTREN bit (CMPCON <10>) should be reset to '0'.

### Affected Silicon Revisions

A1								
X								

## 16. Module: PWM

When the PWMx generator is configured to operate in Current Reset mode (XPRES (PWMCONx<1>) = 1, Independent Time Base mode (ITB (PWMCONx<9>) = 1)), the PWMx Reset will happen only in every alternate PWM cycle.

### Work around

1. Generate an interrupt when the comparator state changes. This interrupt should be high priority and could be either a comparator interrupt or PWMx Fault interrupt. The current-limit interrupt does not function in this mode. Inside the interrupt, update the PHASEx (period value) with a value less than the programmed duty cycle and then immediately update the PHASEx register with the value as required by the application (PWM\_period), as shown in **Example 4**.

### EXAMPLE 4: WORK AROUND CODE

```

PWMx_ISR:
{
    PHASEx = PDCx - 100;
    PHASEx = PWM_period;
    PWMxIF = 0;
}
    
```

2. When the External Current Reset signal is applied to the PWMx generator (configured using the Current-Limit Control Signal Source Select bits (CLSRC<4:0>) in the PWMx Fault Current-Limit Control registers (FCLCONx<14:10>), depending on the PWM resolution selected (PCLKDIV<2:0> (PTCON2<2:0>)), the maximum pulse width of the External Current Reset signal is to be restricted to less than the values as shown in **Table 1**.

**TABLE 1: MAXIMUM EXTERNAL CURRENT RESET SIGNAL WIDTH**

PCLKDIV<2:0>	Max. External Current Reset Signal Width (ns)
000	20
001	40
010	80
011	160
100	320
101	640
110	1280
111	2560

### Affected Silicon Revisions

A1								
X								

## 17. Module: PWM

When External Period Reset mode is enabled, a Reset signal, asserted during the PWM on time, and that continues to be asserted afterwards, will cause the PWM period to be reset immediately after the end of the PWM on time.

The expected behavior is for the External Reset Signal to be ignored if it is still active at the end of the PWM on time.

### Work around

Ensure that the External Period Reset signal is asserted during the PWM off time, and deasserted before the end of the PWM on time.

### Affected Silicon Revisions

A1								
X								

## 18. Module: PWM

Dead time is not asserted when the PWM module is configured in Push-Pull Output mode (PMOD<1:0> (IOCONx<11:10>) = 0b10). As a result, the registers, DTRx and ALDTRx, have no effect when operating in this PWM mode.

### Work around

In order to avoid cross-conduction during a PWM Fault event, ensure that the maximum programmed Duty Cycle register value is always less than the Time Base Period minus the desired dead time ( $PDCx = PWM_{period} - Dead\ Time$ ). There is no work around when the External Period Reset is used in this PWM mode.

### Affected Silicon Revisions

A1								
X								

## 19. Module: PWM

In Edge-Aligned PWM mode with the Independent Time Base Mode (PWMCONx<9> = 0) and Immediate Update Enable (PWMCONx<0> = 0) bits disabled, after enabling the PWMx module (PTCON<15> = 1), changes to the PHASEx register, such that PHASEx < DTRx or PHASEx > PDCx, will result in missing dead time at the PWMxH/PWMxL transition that will occur at the next master period boundary

### Work around

None.

### Affected Silicon Revisions

A1								
X								

## 20. Module: PWM

The Primary PWMx Time Base Capture register (PWMCAPx) automatically captures the independent time base counter value when the rising edge of the current-limit signal is detected. This device feature only works when the Current-Limit Interrupt Enable bit is enabled (CLIEN (PWMCONx<11>) = 1).

### Work around

Enable the Current-Limit Interrupt Enable bit, CLIEN (PWMCONx<11>).

### Affected Silicon Revisions

A1								
X								

## 21. Module: PWM

In Redundant Output mode (IOCONx<11:10> = 01) and Push-Pull Output mode (IOCONx<11:10> = 10) with the Immediate Update Enable bit (PWMCONx<0> = 0) disabled, when the Duty Cycle register is updated from a non-zero value to zero, a glitch pulse of a width equal to 1 PWM clock will appear at the next PWM period boundary, as shown in Figure 2 (for the Redundant Output mode). The Duty Cycle register refers to the PDCx register if PWMCONx<8> = 0 or the MDC register if PWMCONx<8> = 1.

**FIGURE 2: ISSUE EXAMPLE FOR REDUNDANT OUTPUT MODE**

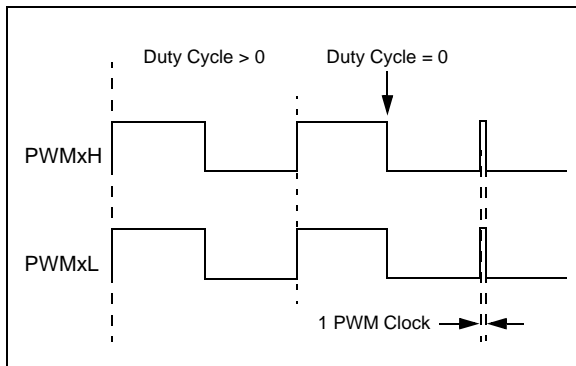

### Work around

If the application requires a zero duty cycle output, there are two possible work around methods:

1. Use the PWM override feature to override the PWM output to a low state instead of writing to the Duty Cycle register. In order to switch back to a non-zero duty cycle output, turn off the PWM override. The override-on and override-off events must be timed close to the PWM period boundary if the IOCONx register has been configured with IOCONx<0> = 0 (i.e., output overrides through the OVRDAT<1:0> bits occur on the next CPU clock boundary).
2. Enable the Immediate Update Enable bit (PWMCONx<0> = 1) while configuring the PWMx module (i.e., before enabling the PWMx module, PTCON<15> = 1). With the Immediate Update enabled, writes to the Duty Cycle register can have an immediate effect on the PWM output. Therefore, the duty cycle write operations must be timed close to the PWM period boundary in order to avoid distortions in the PWM output.

### Affected Silicon Revisions

A1								
X								

## 22. Module: PWM

When the PWM module is configured for Push-Pull mode (IOCONx<11:10> = 10) with the Enable Immediate Period Updates bit enabled (PTCON<10> = 1), a write to the Period register that coincides with the period rollover event may cause the push-pull output logic to produce back-to-back pulses on the PWMx output pins (Figure 3).

**FIGURE 3: ISSUE EXAMPLE IN PUSH-PULL MODE**

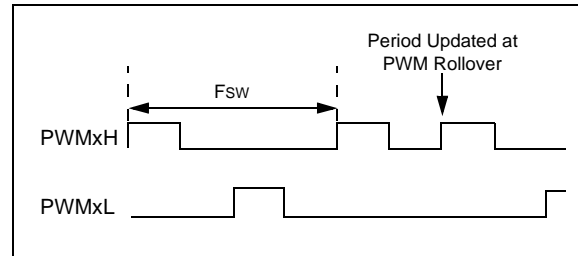

### Work around

Use either the PWMx Special Event Compare (SEVTCMP) or PWMx Primary Trigger Compare Value (TRIGx) to generate a PWM Interrupt Service Routine (ISR) near the start of the PWM cycle. This ISR will ensure that period writes do not occur near the PWM period rollover event.

### Affected Silicon Revisions

A1								
X								

## Data Sheet Clarifications

The following typographic corrections and clarifications are to be noted for the latest version of the device data sheet (DS75018C):

**Note:** Corrections are shown in **bold**. Where possible, the original bold text formatting has been removed for clarity.

### 1. Module: Electrical Characteristics

The Min. and Typ. values in [Table 25-42](#) have been corrected. The correct values are shown in bold below:

**TABLE 25-42: DAC MODULE SPECIFICATIONS**

AC and DC CHARACTERISTICS <sup>(2)</sup>			Standard Operating Conditions (unless otherwise stated) Operating temperature: -40°C ≤ T <sub>A</sub> ≤ +85°C for Industrial -40°C ≤ T <sub>A</sub> ≤ +125°C for Extended				
Param.	Symbol	Characteristic	Min.	Typ.	Max.	Units	Comments
DA01	EXTREF	External Voltage Reference <sup>(1)</sup>	0	—	AVDD – 1.6	V	
DA08	INTREF	Internal Voltage Reference <sup>(1)</sup>	1.15	1.25	1.35	V	
DA02	CVRES	Resolution	10			Bits	
DA03	INL	Integral Nonlinearity Error	<b>-15</b>	-1	<b>+15</b>	LSB	AVDD = 3.3V, DACREF = (AVDD/2)V
DA04	DNL	Differential Nonlinearity Error	-5	-0.5	+5	LSB	
DA05	E0FF	Offset Error	<b>-0.8</b>	<b>0.4</b>	2.6	%	
DA06	EG	Gain Error	<b>-1.8</b>	<b>0.4</b>	5.2	%	
DA07	TSET	Settling Time <sup>(1)</sup>	711	1551	2100	ns	Measured when range = 1 (high range) and the CMREF<9:0> bits transition from 0x1FF to 0x300.

Note 1: Parameters are for design guidance only and are not tested in manufacturing.

2: Overall functional device operation at VBORMIN < VDD < VDDMIN is tested but not characterized. All device analog modules, such as the ADC, etc., will function but with degraded performance below VDDMIN. Refer to Parameter BO10 in Table 25-11 for BOR values.

# dsPIC33FJ06GS001/101A/102A/202A and dsPIC33FJ09GS302

## 2. Module: Oscillator Configuration

The CF bit in Register 8-1 was stated as R/C-0. The correct definition is R/W-0. The (read/clear by application) text has also been removed from the CF bit description on Page 127.

## 3. Module: Oscillator Configuration

The values describing the range of tenability of the internal oscillator in [Register 8-4](#) have been corrected. The correct values are shown in bold below:

### REGISTER 8-4: OSCTUN: FRC OSCILLATOR TUNING REGISTER<sup>(2)</sup>

U-0	U-0	U-0	U-0	U-0	U-0	U-0	U-0
—	—	—	—	—	—	—	—
bit 15						bit 8	

U-0	U-0	R/W-0	R/W-0	R/W-0	R/W-0	R/W-0	R/W-0
—	—	TUN<5:0> <sup>(1)</sup>					—
bit 7						bit 0	

#### Legend:

R = Readable bit

W = Writable bit

U = Unimplemented bit, read as '0'

-n = Value at POR

'1' = Bit is set

'0' = Bit is cleared

x = Bit is unknown

bit 15-6 Unimplemented: Read as '0'

bit 5-0 TUN<5:0>: FRC Oscillator Tuning bits<sup>(1)</sup>

011111 = Center frequency + **1.45% (7.478 MHz)**

011110 = Center frequency + **1.40% (7.4743 MHz)**

•

•

•

000001 = Center frequency + **0.047% (7.3734 MHz)**

000000 = Center frequency (**7.37 MHz**)

111111 = Center frequency – **0.047% (7.366 MHz)**

•

•

•

100001 = Center frequency – **1.453% (7.263 MHz)**

100000 = Center frequency – **1.5% (7.26 MHz)**

Note 1: OSCTUN functionality has been provided to help customers compensate for temperature effects on the FRC frequency over a wide range of temperatures. The tuning step-size is an approximation and is neither characterized nor tested.

2: This register is reset only on a Power-on Reset (POR).

## 4. Module: High-Speed, 10-Bit Analog-to-Digital Converter (ADC)

In [Figure 19-2](#) and [Figure 19-3](#), AN13 has been added and the number of output registers has been changed from eight to seven.

In [Figure 19-5](#), the number of output registers has been changed from eight to ten. The changes are shown in bold below:

**FIGURE 19-2: ADC BLOCK DIAGRAM FOR THE dsPIC33FJ06GS101A DEVICE**

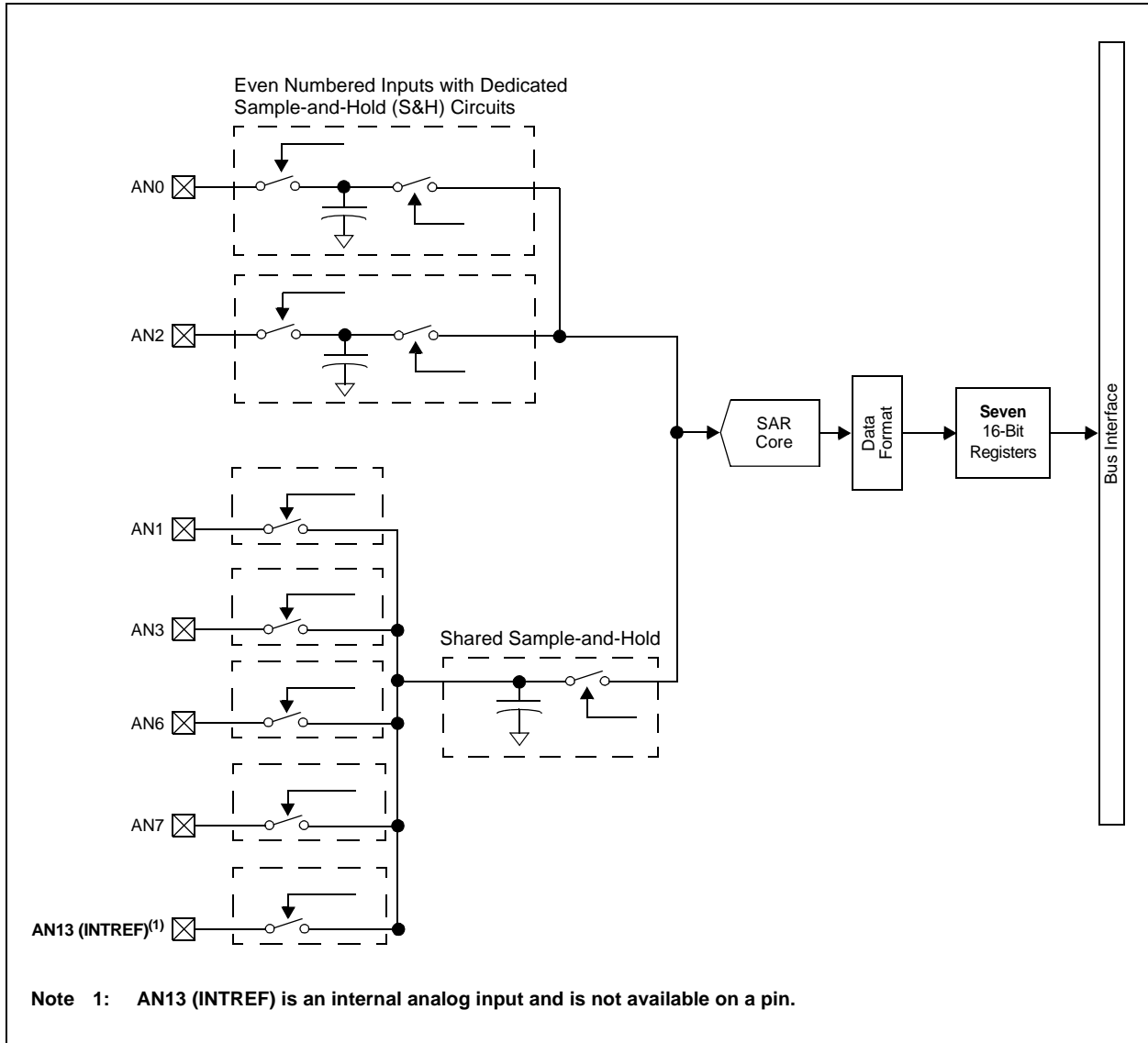

**FIGURE 19-3: ADC BLOCK DIAGRAM FOR THE dsPIC33FJ06GS102A DEVICE**

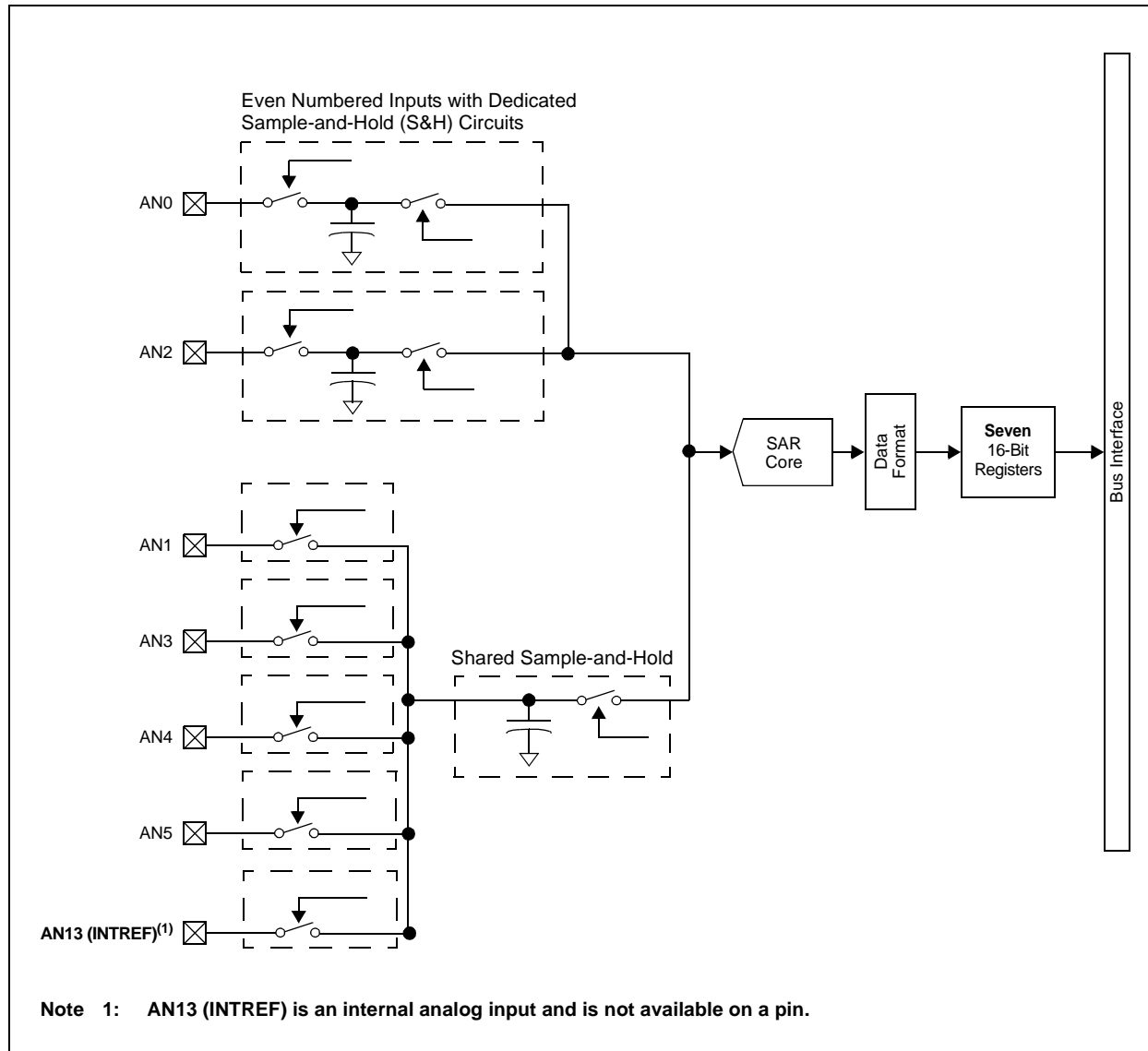
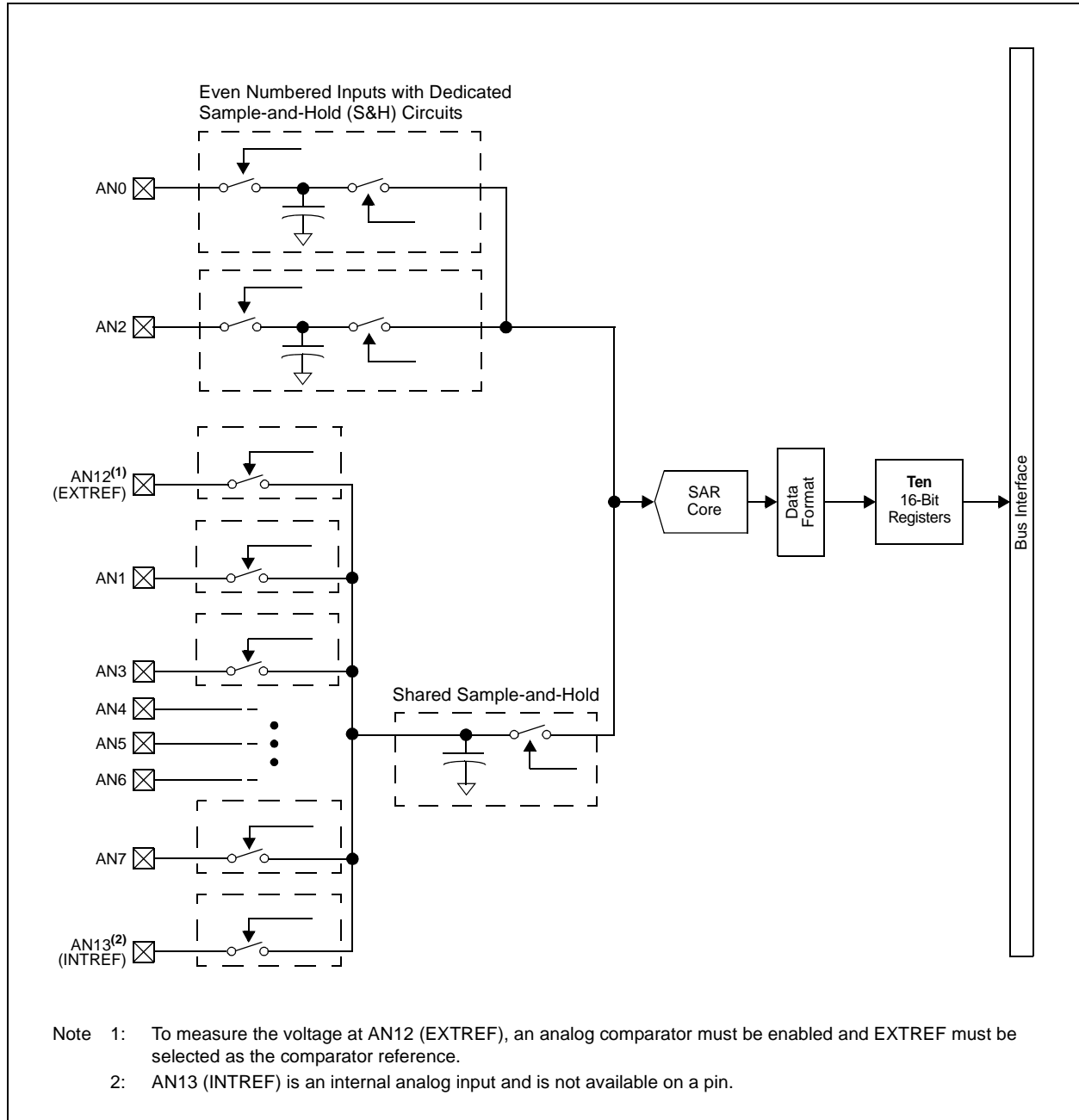

FIGURE 19-5: ADC BLOCK DIAGRAM FOR THE dsPIC33FJ09GS302 DEVICE



## 5. Module: Electrical Characteristics

In Table 25-43, the text for the Characteristics of DA13 (VRANGE) and DA14 (VLRANGE) is corrected as follows (changes in **bold**):

- for DA13, Current Drive of **300  $\mu$ A**
- for DA14, Current Drive of **50  $\mu$ A**

## 6. Module: Packaging

A new packaging type, Ultra-Thin Quad Flat Pack No Lead, 6 mm x 6 mm x 0.5 mm (UQFN), was added for the dsPIC33FJ09GS302 28-pin device.

The 28-pin UQFN package shares the same pin configurations as the existing 28-pin QFN-S packages. Users may refer to the existing QFN pin diagrams at the front of the device data sheet for the appropriate pin configurations.

The format of package marking in **Section 27.1 “Package Marking Information”** is identical to that of the existing 28-pin QFN-S packaging. The sole difference is that UQFN packages are marked “/MX” in the second line, instead of “/MM” for QFN-S devices.

The following additions are made to the device data sheet:

- Microchip Technology Drawing C04-0209B, three sheets (“28-Lead Plastic Ultra-Thin Quad Flat, No Lead Package”) are added by reference to **Section 27.2 “Packaging Details”**. The latest version of these drawings is in Microchip Technology document DS00000049, “*Packaging Specification*”, available at the Microchip web site, at [www.microchip.com/packaging](http://www.microchip.com/packaging).
- The data sheet “**Product Information System**” section is amended to add package type “MX, Plastic Ultra-Thin Quad Flat, No Lead Package –6 mm x 6 mm x 0.5 mm (UQFN)”.

## APPENDIX A: REVISION HISTORY

### Rev A Document (3/2012)

Initial release of this document; issued for revision A0 silicon.

Included silicon issues 1 (CPU), 2 (CPU), 3 (GPIO), 4 (PGEC2/PGED2 Programming Pins (dsPIC33FJ06GS001/101A/102A Devices Only)), 5-9 (PWM), 10 (Sleep Mode), 11 (Sleep Mode), 12 (SPI), 13 (SPI), 14 (UART), 15 (UART), 16 (Comparator), and 17 (Comparator).

### Rev B Document (7/2012)

Removes silicon revision A0 and all issues, as this revision was never released.

Adds silicon revision A1 in its place. Includes new silicon issues 1-2 (CPU), 3-5 (PWM), 6 (CPU), 7-8 (SPI), 9-10 (UART) and 11-12 (Comparator).

### Rev C Document (1/2013)

Adds silicon revisions 13-14 (PWM).

### Rev D Document (2/2013)

Adds silicon issue 15 (Comparator). Adds data sheet clarifications 1 (Electrical Characteristics), 2-3 (Oscillator Configuration) and 4 (High-Speed, 10-Bit Analog-to-Digital Converter (ADC)).

### Rev E Document (9/2013)

Adds silicon issues 16 and 17 (PWM).

Revises silicon issue 13 (PWM) with an updated description of the issue and a different work around.

Adds data sheet clarifications 5 (Electrical Characteristics) and 6 (Packaging).

Revises data sheet clarification 1 (Electrical Characteristics) to add corrections to specification DA03.

### Rev F Document (9/2014)

Adds silicon issues 18-22 (PWM).

# **dsPIC33FJ06GS001/101A/102A/202A and dsPIC33FJ09GS302**

---

NOTES:

---

**Note the following details of the code protection feature on Microchip devices:**

- Microchip products meet the specification contained in their particular Microchip Data Sheet.
- Microchip believes that its family of products is one of the most secure families of its kind on the market today, when used in the intended manner and under normal conditions.
- There are dishonest and possibly illegal methods used to breach the code protection feature. All of these methods, to our knowledge, require using the Microchip products in a manner outside the operating specifications contained in Microchip's Data Sheets. Most likely, the person doing so is engaged in theft of intellectual property.
- Microchip is willing to work with the customer who is concerned about the integrity of their code.
- Neither Microchip nor any other semiconductor manufacturer can guarantee the security of their code. Code protection does not mean that we are guaranteeing the product as “unbreakable.”

Code protection is constantly evolving. We at Microchip are committed to continuously improving the code protection features of our products. Attempts to break Microchip's code protection feature may be a violation of the Digital Millennium Copyright Act. If such acts allow unauthorized access to your software or other copyrighted work, you may have a right to sue for relief under that Act.

---

Information contained in this publication regarding device applications and the like is provided only for your convenience and may be superseded by updates. It is your responsibility to ensure that your application meets with your specifications. MICROCHIP MAKES NO REPRESENTATIONS OR WARRANTIES OF ANY KIND WHETHER EXPRESS OR IMPLIED, WRITTEN OR ORAL, STATUTORY OR OTHERWISE, RELATED TO THE INFORMATION, INCLUDING BUT NOT LIMITED TO ITS CONDITION, QUALITY, PERFORMANCE, MERCHANTABILITY OR FITNESS FOR PURPOSE. Microchip disclaims all liability arising from this information and its use. Use of Microchip devices in life support and/or safety applications is entirely at the buyer's risk, and the buyer agrees to defend, indemnify and hold harmless Microchip from any and all damages, claims, suits, or expenses resulting from such use. No licenses are conveyed, implicitly or otherwise, under any Microchip intellectual property rights.

#### **Trademarks**

The Microchip name and logo, the Microchip logo, dsPIC, FlashFlex, flexPWR, JukeBlox, KEELOQ, KEELOQ logo, Klear, LANCheck, MediaLB, MOST, MOST logo, MPLAB, OptoLyzer, PIC, PICSTART, PIC<sup>32</sup> logo, RightTouch, SpyNIC, SST, SST Logo, SuperFlash and UNI/O are registered trademarks of Microchip Technology Incorporated in the U.S.A. and other countries.

The Embedded Control Solutions Company and mTouch are registered trademarks of Microchip Technology Incorporated in the U.S.A.

Analog-for-the-Digital Age, BodyCom, chipKIT, chipKIT logo, CodeGuard, dsPICDEM, dsPICDEM.net, ECAN, In-Circuit Serial Programming, ICSP, Inter-Chip Connectivity, KlearNet, KlearNet logo, MiWi, MPASM, MPF, MPLAB Certified logo, MPLIB, MPLINK, MultiTRAK, NetDetach, Omniscient Code Generation, PICDEM, PICDEM.net, PICkit, PICtail, RightTouch logo, REAL ICE, SQI, Serial Quad I/O, Total Endurance, TSHARC, USBCheck, VariSense, ViewSpan, WiperLock, Wireless DNA, and ZENA are trademarks of Microchip Technology Incorporated in the U.S.A. and other countries.

SQTP is a service mark of Microchip Technology Incorporated in the U.S.A.

Silicon Storage Technology is a registered trademark of Microchip Technology Inc. in other countries.

GestIC is a registered trademarks of Microchip Technology Germany II GmbH & Co. KG, a subsidiary of Microchip Technology Inc., in other countries.

All other trademarks mentioned herein are property of their respective companies.

© 2012-2014, Microchip Technology Incorporated, Printed in the U.S.A., All Rights Reserved.

ISBN: 978-1-63276-603-8

**QUALITY MANAGEMENT SYSTEM**  
**CERTIFIED BY DNV**  
**== ISO/TS 16949 ==**

*Microchip received ISO/TS-16949:2009 certification for its worldwide headquarters, design and wafer fabrication facilities in Chandler and Tempe, Arizona; Gresham, Oregon and design centers in California and India. The Company's quality system processes and procedures are for its PIC<sup>®</sup> MCUs and dsPIC<sup>®</sup> DSCs, KEELOQ<sup>®</sup> code hopping devices, Serial EEPROMs, microperipherals, nonvolatile memory and analog products. In addition, Microchip's quality system for the design and manufacture of development systems is ISO 9001:2000 certified.*



# MICROCHIP

## Worldwide Sales and Service

### AMERICAS

**Corporate Office**  
2355 West Chandler Blvd.  
Chandler, AZ 85224-6199  
Tel: 480-792-7200  
Fax: 480-792-7277  
Technical Support:  
<http://www.microchip.com/support>  
Web Address:  
[www.microchip.com](http://www.microchip.com)

**Atlanta**  
Duluth, GA  
Tel: 678-957-9614  
Fax: 678-957-1455

**Austin, TX**  
Tel: 512-257-3370

**Boston**  
Westborough, MA  
Tel: 774-760-0087  
Fax: 774-760-0088

**Chicago**  
Itasca, IL  
Tel: 630-285-0071  
Fax: 630-285-0075

**Cleveland**  
Independence, OH  
Tel: 216-447-0464  
Fax: 216-447-0643

**Dallas**  
Addison, TX  
Tel: 972-818-7423  
Fax: 972-818-2924

**Detroit**  
Novi, MI  
Tel: 248-848-4000

**Houston, TX**  
Tel: 281-894-5983

**Indianapolis**  
Noblesville, IN  
Tel: 317-773-8323  
Fax: 317-773-5453

**Los Angeles**  
Mission Viejo, CA  
Tel: 949-462-9523  
Fax: 949-462-9608

**New York, NY**  
Tel: 631-435-6000

**San Jose, CA**  
Tel: 408-735-9110

**Canada - Toronto**  
Tel: 905-673-0699  
Fax: 905-673-6509

### ASIA/PACIFIC

**Asia Pacific Office**  
Suites 3707-14, 37th Floor  
Tower 6, The Gateway  
Harbour City, Kowloon  
Hong Kong  
Tel: 852-2943-5100  
Fax: 852-2401-3431

**Australia - Sydney**  
Tel: 61-2-9868-6733  
Fax: 61-2-9868-6755

**China - Beijing**  
Tel: 86-10-8569-7000  
Fax: 86-10-8528-2104

**China - Chengdu**  
Tel: 86-28-8665-5511  
Fax: 86-28-8665-7889

**China - Chongqing**  
Tel: 86-23-8980-9588  
Fax: 86-23-8980-9500

**China - Hangzhou**  
Tel: 86-571-8792-8115  
Fax: 86-571-8792-8116

**China - Hong Kong SAR**  
Tel: 852-2943-5100  
Fax: 852-2401-3431

**China - Nanjing**  
Tel: 86-25-8473-2460  
Fax: 86-25-8473-2470

**China - Qingdao**  
Tel: 86-532-8502-7355  
Fax: 86-532-8502-7205

**China - Shanghai**  
Tel: 86-21-5407-5533  
Fax: 86-21-5407-5066

**China - Shenyang**  
Tel: 86-24-2334-2829  
Fax: 86-24-2334-2393

**China - Shenzhen**  
Tel: 86-755-8864-2200  
Fax: 86-755-8203-1760

**China - Wuhan**  
Tel: 86-27-5980-5300  
Fax: 86-27-5980-5118

**China - Xian**  
Tel: 86-29-8833-7252  
Fax: 86-29-8833-7256

**China - Xiamen**  
Tel: 86-592-2388138  
Fax: 86-592-2388130

**China - Zhuhai**  
Tel: 86-756-3210040  
Fax: 86-756-3210049

### ASIA/PACIFIC

**India - Bangalore**  
Tel: 91-80-3090-4444  
Fax: 91-80-3090-4123

**India - New Delhi**  
Tel: 91-11-4160-8631  
Fax: 91-11-4160-8632

**India - Pune**  
Tel: 91-20-3019-1500

**Japan - Osaka**  
Tel: 81-6-6152-7160  
Fax: 81-6-6152-9310

**Japan - Tokyo**  
Tel: 81-3-6880-3770  
Fax: 81-3-6880-3771

**Korea - Daegu**  
Tel: 82-53-744-4301  
Fax: 82-53-744-4302

**Korea - Seoul**  
Tel: 82-2-554-7200  
Fax: 82-2-558-5932 or  
82-2-558-5934

**Malaysia - Kuala Lumpur**  
Tel: 60-3-6201-9857  
Fax: 60-3-6201-9859

**Malaysia - Penang**  
Tel: 60-4-227-8870  
Fax: 60-4-227-4068

**Philippines - Manila**  
Tel: 63-2-634-9065  
Fax: 63-2-634-9069

**Singapore**  
Tel: 65-6334-8870  
Fax: 65-6334-8850

**Taiwan - Hsin Chu**  
Tel: 886-3-5778-366  
Fax: 886-3-5770-955

**Taiwan - Kaohsiung**  
Tel: 886-7-213-7830

**Taiwan - Taipei**  
Tel: 886-2-2508-8600  
Fax: 886-2-2508-0102

**Thailand - Bangkok**  
Tel: 66-2-694-1351  
Fax: 66-2-694-1350

### EUROPE

**Austria - Wels**  
Tel: 43-7242-2244-39  
Fax: 43-7242-2244-393

**Denmark - Copenhagen**  
Tel: 45-4450-2828  
Fax: 45-4485-2829

**France - Paris**  
Tel: 33-1-69-53-63-20  
Fax: 33-1-69-30-90-79

**Germany - Dusseldorf**  
Tel: 49-2129-3766400

**Germany - Munich**  
Tel: 49-89-627-144-0  
Fax: 49-89-627-144-44

**Germany - Pforzheim**  
Tel: 49-7231-424750

**Italy - Milan**  
Tel: 39-0331-742611  
Fax: 39-0331-466781

**Italy - Venice**  
Tel: 39-049-7625286

**Netherlands - Drunen**  
Tel: 31-416-690399  
Fax: 31-416-690340

**Poland - Warsaw**  
Tel: 48-22-3325737

**Spain - Madrid**  
Tel: 34-91-708-08-90  
Fax: 34-91-708-08-91

**Sweden - Stockholm**  
Tel: 46-8-5090-4654

**UK - Wokingham**  
Tel: 44-118-921-5800  
Fax: 44-118-921-5820

03/25/14

## Looking for pricing, stock, or lifecycle information?

Click below to explore more details on WIN SOURCE:

- ⊖ [View DSPIC33FJ06GS101A-I/SO on WIN SOURCE](#)
- ⊖ [Microchip Technology](#) Information

## Optimize Your Supply Chain with WIN SOURCE Solutions

- ✓ Global Sourcing Solution
- ✓ Obsolete Management
- ✓ Cost Control Management
- ✓ Shortage Management
- ✓ Alternative Solution
- ✓ Excess Inventory Management