



**THE DATASHEET OF  
DS8102+**



# Dual Delta-Sigma Modulator and Encoder

## General Description

The DS8102 is a stand-alone, dual-channel, delta-sigma modulator that converts measurements from two differential analog input pairs into a Manchester-encoded output bit stream that can be processed by a companion microcontroller such as the MAXQ3108. One channel operates at a fixed 1x gain, while the other operates at a pin-selectable gain of 1x, 4x, 16x, or 32x. The DS8102 includes an internal power-supply monitor, on-board voltage reference, and low-power oscillator to reduce the number of external components required for data acquisition.

The Manchester-encoded output from the DS8102 combines pulse-density-modulated measurement values from both differential input channels with a synchronization bit stream and is transmitted over a single pin. This transmission scheme is ideal for split voltage domain applications where the DS8102 and other "hot"-side components must be electrically isolated from "cold" low-voltage components such as a companion microcontroller. In this type of application, the DS8102 can be capacitively coupled to a companion microcontroller with only two connection points required (MNOUT and DGND).

The MAXQ3108 dual-core microcontroller, which includes specialized Manchester bit-stream decoding inputs and sinc3 filters, is specifically designed to act as a companion microcontroller for up to three DS8102 devices. This configuration, which supports up to six differential analog input channels, is well suited for three-phase electricity-metering applications.

## Applications

- Single-Phase Electricity Metering
- Three-Phase Electricity Metering
- Power-Line Conditioning
- Electrochemical and Optical Sensors
- Industrial Control
- Data-Acquisition Systems and Data Loggers

Typical Operating Circuit appears at end of data sheet.

MAXQ is a registered trademark of Maxim Integrated Products, Inc.

## Features

- ◆ Dual Delta-Sigma 2nd-Order Modulators
  - Channel 0: Pin-Selectable Gain of 1x, 4x, 16x, or 32x
  - Channel 1: Fixed Gain of 1x
- ◆ Selectable Internal or External Voltage Reference
- ◆ Manchester-Encoded Bit Stream Output
  - Includes Synchronization Bits to Allow Clock Recovery
  - Single-Pin Transmission Scheme Simplifies Electrical Isolation Using Capacitive Coupling
- ◆ Selectable Internal or External Clock Source
- ◆ Integrated Low-Power 8MHz Oscillator
- ◆ Operating Mode
  - Active Mode (8MHz,  $V_{DD} = 3.6V$ ): 3.5mA

## Ordering Information

PART	TEMP RANGE	PIN-PACKAGE
DS8102+	-40°C to +85°C	16 TSSOP

+Denotes a lead(Pb)-free/RoHS-compliant package.

## Pin Configuration

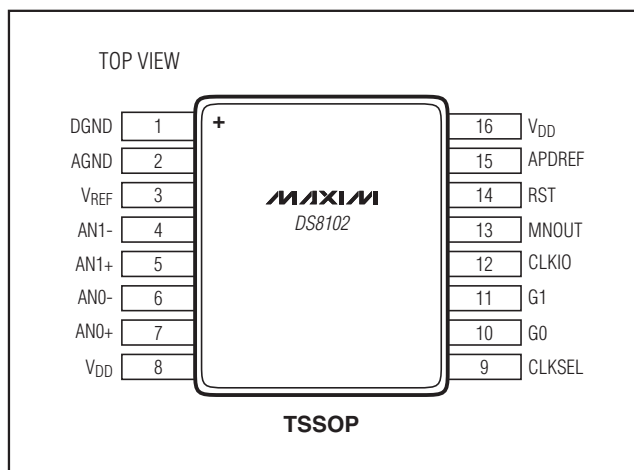

# Dual Delta-Sigma Modulator and Encoder

## ABSOLUTE MAXIMUM RATINGS

Voltage Range on V<sub>DD</sub> Relative to DGND.....-0.3V to +4.0V  
 Voltage Range on V<sub>DD</sub> Relative to AGND.....-0.3V to +4.0V  
 Voltage Range on AGND Relative to DGND.....-0.3V to +0.3V  
 Voltage Range on Any Pin Relative to DGND  
 Except AN0+, AN0-, and AN1+, AN1-.....-0.3V to +4.0V

Voltage Range on AN0+, AN0-, AN1+, and AN1-  
 Relative to AGND .....-4.0V to +4.0V  
 Operating Temperature Range .....-40°C to +85°C  
 Storage Temperature Range .....-65°C to +150°C  
 Soldering Temperature.....Refer to the IPC/JEDEC  
 J-STD-020 Specification.

Stresses beyond those listed under "Absolute Maximum Ratings" may cause permanent damage to the device. These are stress ratings only, and functional operation of the device at these or any other conditions beyond those indicated in the operational sections of the specifications is not implied. Exposure to absolute maximum rating conditions for extended periods may affect device reliability.

## ELECTRICAL CHARACTERISTICS

(V<sub>DD</sub> = 2.7V to 3.6V, T<sub>A</sub> = -40°C to +85°C, f<sub>CLK</sub> = 8MHz, V<sub>REF</sub> = internal, OSR = 128, unless otherwise noted.) (Note 1)

PARAMETER	SYMBOL	CONDITIONS	MIN	TYP (Note 2)	MAX	UNITS
Supply Voltage	V <sub>DD</sub>		V <sub>RST</sub>	3.3	3.6	V
Power-Fail Reset Voltage	V <sub>RST</sub>	Monitors V <sub>DD</sub>	2.7	2.8	2.99	V
Active V <sub>DD</sub> Current	I <sub>DD</sub>	Normal operation		3.5	5.0	mA
Shutdown (Power-Down) V <sub>DD</sub> Current	I <sub>STOP</sub>	RST = 0 or V <sub>DD</sub> < V <sub>RST</sub>		2		nA
Input Low Voltage	V <sub>IL</sub>		DGND		0.3 x V <sub>DD</sub>	V
Input High Voltage	V <sub>IH</sub>		0.7 x V <sub>DD</sub>		V <sub>DD</sub>	V
Output Low Voltage (CLKIO, MNOOUT)	V <sub>OL</sub>	I <sub>OL</sub> = 4mA	DGND		0.4	V
Output High Voltage (CLKIO, MNOOUT)	V <sub>OH</sub>	I <sub>OH</sub> = -4mA	V <sub>DD</sub> - 0.4			V
Input/Output Pin Capacitance	C <sub>IO</sub>	(Note 3)			15	pF
Input Leakage Current (All Inputs)	I <sub>L</sub>		-100		+100	nA
<b>CLOCK SOURCE</b>						
External Clock Input Frequency	f <sub>XCLK</sub>	CLKSEL = 1	DC		8	MHz
External Clock Input Period	t <sub>XCLK-CLCL</sub>	CLKSEL = 1	125			ns
External Clock Input Duty Cycle	t <sub>XCLK-DUTY</sub>	CLKSEL = 1	40		60	%
Internal Oscillator Output Frequency	f <sub>ICLK</sub>	CLKSEL = 0	7.5	8.0	8.5	MHz
Internal Oscillator Output Duty Cycle	t <sub>ICLK-DUTY</sub>	CLKSEL = 0	47.8	49.1	49.7	%
<b>ANALOG-TO-DIGITAL CONVERTER</b>						
AFE Warmup Delay	t <sub>WU1</sub>	f <sub>ICLK</sub> = 8MHz (Notes 1, 4)			1.02	ms
Reference Buffer Warmup Delay	t <sub>WU2</sub>	f <sub>ICLK</sub> = 8MHz (Notes 1, 5)			7.17	ms
Decimator Output (Note 6)		OSR = 32		16		Bits
		OSR = 64		19		
		OSR = 128		22		
		OSR = 256		24		
Integral Nonlinearity	INL	(Notes 1, 6)		±0.01		%FSR
Offset Error		Gain = 1 (Note 6)			1.4	mV

# Dual Delta-Sigma Modulator and Encoder

## ELECTRICAL CHARACTERISTICS (continued)

( $V_{DD} = 2.7V$  to  $3.6V$ ,  $T_A = -40^{\circ}C$  to  $+85^{\circ}C$ ,  $f_{CLK} = 8MHz$ ,  $V_{REF} = \text{internal}$ ,  $OSR = 128$ , unless otherwise noted.) (Note 1)

PARAMETER	SYMBOL	CONDITIONS	MIN	TYP (Note 2)	MAX	UNITS
<b>ANALOG-TO-DIGITAL CONVERTER DYNAMIC SPECIFICATIONS</b>						
DC Power-Supply Rejection Ratio	PSRR	$V_{DD} = 3.0V$ to $3.6V$ , $AN0+ = AN0- = AGND$ , 100mV ripple on $V_{DD}$		95		dB
Signal-to-Noise Ratio	SINAD	$V_{DD} = 3.6V$ , gain = 1, $AN0 = 500mV_{P-P}$ , sinewave at 62.5Hz	70	85		dB
		$V_{DD} = 3.6V$ , gain = 32, $AN0 = 20mV_{P-P}$ , sinewave at 62.5Hz	70	85		
Total Harmonic Distortion (to 21st Harmonic)	THD	$V_{DD} = 3.6V$ , gain = 32, $AN0 = 20mV_{P-P}$ , sinewave at 62.5Hz		-95	-70	dB
<b>ANALOG-TO-DIGITAL CONVERTER INPUTS</b>						
Input Voltage Range		$AN0+$ , $AN0-$ , $AN1+$ , and $AN1-$ to AGND	-1		+1	V
Input Sampling Capacitance (Note 1)	$C_{IN}$	Gain = 1		1		pF
		Gain = 4		4		
		Gain = 16		16		
		Gain = 32		32		
Input Sampling Rate	$f_S$	Clock at 8MHz (Note 7)		0.667		MHz
Input Impedance to AGND for 8MHz (Note 8)		Gain = 1		750		k $\Omega$
		Gain = 4		187		
		Gain = 16		47		
		Gain = 32		23.4		
Differential Input Impedance for 8MHz (Note 9)		Gain = 1		1500		k $\Omega$
		Gain = 4		375		
		Gain = 16		94		
		Gain = 32		46.9		
Input Bandwidth (-3dB)				7		kHz
External Reference Input Voltage	$V_{REF}$		1.2	1.25	1.3	V
External Reference Input Sampling Capacitance				2		pF
Reference Input Sampling Rate	$f_S$			0.67	1	MHz
<b>INTERNAL REFERENCE</b>						
Reference Output Voltage				1.24		V
Reference Output Temperature Coefficient				$\pm 30$		ppm/ $^{\circ}C$

**Note 1:** Specifications to  $-40^{\circ}C$  are guaranteed by design and not production tested.

**Note 2:** Typical values are not guaranteed. These values are measured at room temperature,  $V_{DD} = 3.3V$ .

**Note 3:** These numbers are guaranteed by design and are not tested.

**Note 4:** Calculated as  $t_{WU1} = 1/f_{I_{CLK}} \times 8192$ .

**Note 5:** Calculated as  $t_{WU2} = 1/f_{I_{CLK}} \times 57,344$ .

**Note 6:** Parameter specifications are based upon the presence of an external cubic sinc filter (as implemented in the MAXQ3108) for generating full ADC output codewords.

**Note 7:**  $f_S = f_{CLK}/12$ .  $f_{CLK}$  is the system clock frequency.

**Note 8:** This is a function of input sampling capacitance ( $C_{IN}$ ) and sampling frequency, and can be approximated as  $6/(f_{CLK} \times C_{IN})$ .

**Note 9:**  $Z_{IN}$  (differential) =  $2 \times Z_{IN}$  (single-ended).

# Dual Delta-Sigma Modulator and Encoder

## Pin Description

PIN	NAME	FUNCTION
1	DGND	Digital Ground
2	AGND	Analog Ground
3	VREF	Reference Voltage Input/Output. When APDREF = 0, the buffered internal voltage reference is driven on this pin as an output and can be used by other devices. When APDREF = 1, an external voltage reference must be provided on this pin.
4	AN1-	Negative Input for Differential Analog Input Channel 1
5	AN1+	Positive Input for Differential Analog Input Channel 1
6	AN0-	Negative Input for Differential Analog Input Channel 0
7	AN0+	Positive Input for Differential Analog Input Channel 0
8, 16	VDD	Digital and Analog Power Supply
9	CLKSEL	Clock Select Input. When CLKSEL = 0, the DS8102 uses its internal 8MHz oscillator as a clock source. When CLKSEL = 1, the DS8102 operates from an external clock source (which must be provided at CLKIO).
10	G0	Gain Select Input 0. This pin, along with G1, is used to select the gain setting for differential analog input channel 0.
11	G1	Gain Select Input 1. This pin, along with G0, is used to select the gain setting for differential analog input channel 0.
12	CLKIO	Clock Input/Output. When CLKSEL = 0 (internal clock selected), the internal 8MHz clock is output on this pin and can be used by external devices. When CLKSEL = 1 (external clock selected), an external clock must be provided on this pin.
13	MNOUT	Manchester Encoder Output. This output pin provides a Manchester-encoded bit stream containing output bits from both modulators interleaved with an alternating synchronization bit.
14	RST	Reset. This input pin can be used to force the DS8102 into a shutdown (low-power) state by driving RST = 0. If the external reset function is not used, this pin must be connected to VDD for proper operation. An RC circuit is not required on this pin for power-up, as this function is provided internally.
15	APDREF	Analog Power-Down Reference. This input pin controls whether the internal voltage reference is enabled. If APDREF = 0, the internal voltage reference is enabled and the voltage reference level is driven out on VREF. If APDREF = 1, the internal voltage reference is disabled and an external voltage reference must be provided on VREF.

# Dual Delta-Sigma Modulator and Encoder

## Functional Diagram

DS8102

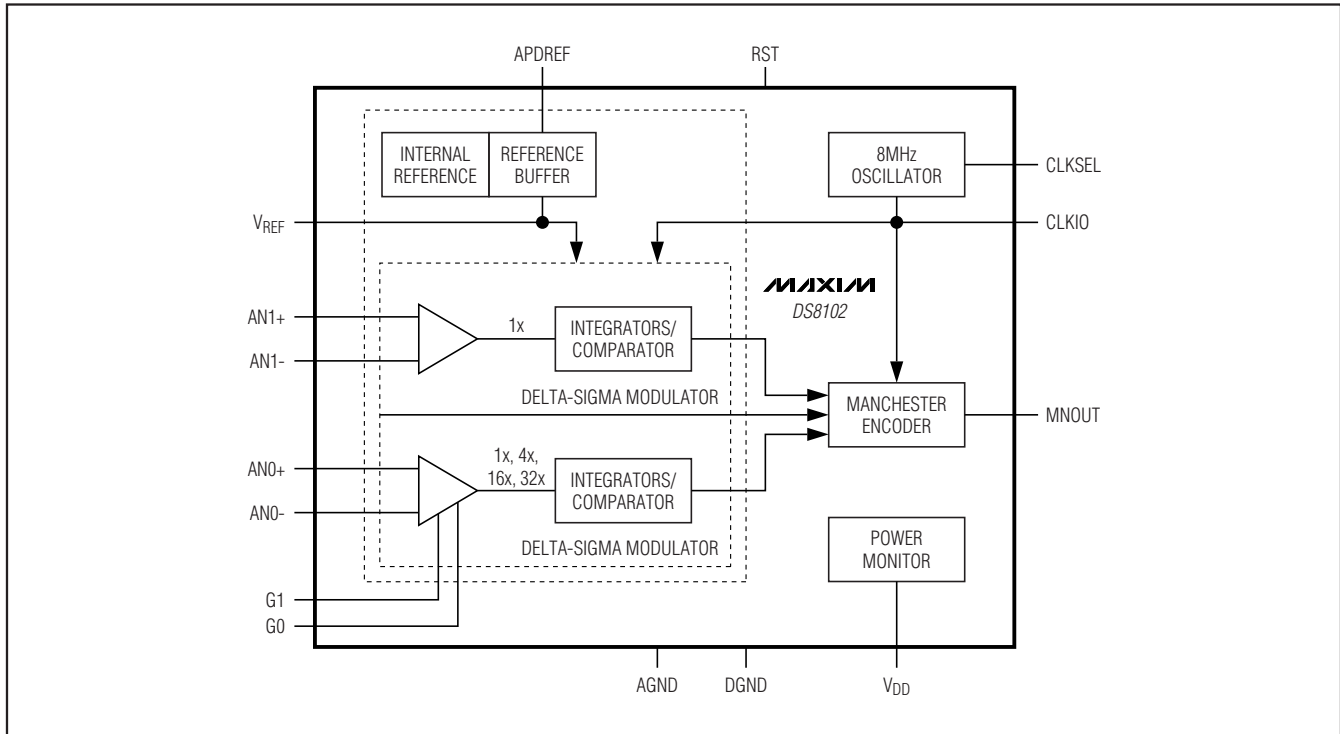

## Detailed Description

### Operating Modes

The DS8102 has two operating modes: shutdown (or power-down) mode and active mode.

### Shutdown Mode

In shutdown mode, the DS8102 is in an inactive state and consumes a minimal amount of current. No analog-to-digital conversion or encoding is performed, and the internal 8MHz oscillator and internal voltage reference are disabled.

An integrated power-supply monitor holds the DS8102 in shutdown mode whenever  $V_{DD} \leq V_{RST}$ . Additionally, the RST pin can be driven low by an external companion microcontroller (such as the MAXQ3108) to force the DS8102 to remain in shutdown mode, regardless of the supply level at  $V_{DD}$ . This is useful in nonisolated configurations (when a power supply is shared between the DS8102 and the companion microcontroller) to reduce the current consumption of the entire system. In this scenario, the companion microcontroller would perform this sequence of actions when entering stop mode:

- 1) Drive the RST line on the DS8102 low to force the DS8102 into shutdown mode.
- 2) Enter stop mode. Both the companion microcontroller and the DS8102 are now in their lowest current consumption modes.
- 3) Exit stop mode.
- 4) Drive the RST line on the DS8102 high to return the DS8102 to active mode.

**Note: The RST line on the DS8102 does not include a pullup. This means that if the RST line is not driven by a companion microcontroller, RST must be connected to  $V_{DD}$  for proper operation. RST cannot be left unconnected.**

While the DS8102 is in shutdown mode, the levels on the configuration input pins (APDREF, CLKSEL, G1, and G0) can be changed if they are being driven by a companion microcontroller instead of hardwired to  $V_{DD}$  or DGND. However, once the DS8102 enters active mode, the levels on these pins must remain static for proper operation.

## Dual Delta-Sigma Modulator and Encoder

Once the power supply is at an acceptable level ( $V_{DD} > V_{RST}$ ) and the RST line is driven high, the DS8102 exits shutdown mode. However, a warmup sequence must then be completed before analog-to-digital conversion and Manchester encoding begins. The length of this sequence depends on the internal/external voltage reference mode (controlled by the APDREF pin).

If the external voltage reference is selected (APDREF = 1), the following actions are performed:

- 1) Upon exit from shutdown mode ( $V_{DD} > V_{RST}$  and RST = 1), the 8MHz oscillator is started.
- 2) The DS8102 delays for 16 cycles of the 8MHz oscillator. This allows the 8MHz oscillator to warm up.
- 3) The analog front-end (AFE) is enabled.
- 4) The DS8102 delays for 8192 cycles of the 8MHz oscillator. This allows the AFE to warm up.
- 5) If CLKSEL = 1, the 8MHz oscillator is disabled at this point and the DS8102 switches to the external clock source provided at CLKIO.
- 6) Both modulator channels are enabled, and the DS8102 begins performing conversions using the external voltage reference.

If the internal voltage reference is selected (APDREF = 0), the following actions are performed:

- 1) Upon exit from shutdown mode ( $V_{DD} > V_{RST}$  and RST = 1), the 8MHz oscillator is started.
- 2) The DS8102 delays for 16 cycles of the 8MHz oscillator. This allows the 8MHz oscillator to warm up.
- 3) The AFE is enabled.
- 4) The DS8102 delays for 8192 cycles of the 8MHz oscillator. This allows the AFE to warm up.
- 5) The internal voltage reference is enabled.
- 6) The DS8102 delays for an additional 57,344 cycles of the 8MHz oscillator. This allows the internal reference to warm up.
- 7) If CLKSEL = 1, the 8MHz oscillator is disabled at this point and the DS8102 switches to the external clock source provided at CLKIO.
- 8) Both modulator channels are enabled, and the DS8102 begins performing conversions using the internal voltage reference.

Even if the external clock has been selected by setting CLKSEL = 1, the internal 8MHz oscillator is still used to control the warmup sequence. Once the warmup sequence has completed, the internal 8MHz oscillator is disabled if CLKSEL = 1.

### Active Mode

In active mode, the AFE and delta-sigma modulators on the DS8102 are enabled, and the DS8102 converts and outputs samples over the Manchester-encoded output (MNOOUT) at a rate determined by either the internal 8MHz oscillator (if CLKSEL = 0) or the external clock input at CLKIO (if CLKSEL = 1).

If RST is driven low or if  $V_{DD}$  drops below the  $V_{RST}$  level, the DS8102 enters shutdown mode immediately and must go through the warmup sequence again (once  $V_{DD} > V_{RST}$  and RST = 1) to return to active mode.

### Configuration Inputs

The input pins G0, G1, APDREF, and CLKSEL are configuration inputs for the DS8102 that determine its operating mode, including:

- Clock selection—internal or external
- Voltage reference—internal or external
- Gain setting for analog input channel 0—1x, 4x, 16x, or 32x

These pins must be set to a valid level for proper operation; they cannot be left disconnected. If any of the configuration inputs are driven by a companion microcontroller (as opposed to being statically connected to  $V_{DD}$  or DGND), the inputs can only be changed when the DS8102 is in shutdown mode.

### Channel 0 Gain Selection

Configuration input pins G0 and G1 are used to select the gain setting for analog input channel 0. The available gain configurations are 1x, 4x, 16x, and 32x. The effective input voltage range scales downward proportionally with each increased gain selection. For example, full-scale output at gain = 1x occurs when AN0+ is 2V higher than AN0-. However, with the gain setting at 4x, the output reaches full scale when AN0+ is only 500mV higher than AN0-.

Table 1 lists the gain configuration settings available for channel 0. The levels at G0 and G1 should be set when the DS8102 is in shutdown mode.

**Table 1. Modulator 0 Gain Settings**

G1 PIN	G0 PIN	GAIN
0	0	1x
0	1	4x
1	0	16x
1	1	32x

# Dual Delta-Sigma Modulator and Encoder

## Internal/External Voltage Reference Selection

The configuration pin APDREF selects whether the DS8102 uses its internal voltage reference or an external voltage reference provided at VREF when performing conversions. If the internal voltage reference is selected, the internal reference is buffered and driven out at VREF, and can be used by external devices if desired.

Table 2 summarizes the modes of operation for the DS8102 based on the APDREF input. The level at APDREF should be set when the DS8102 is in shutdown mode.

## Internal/External Clock Selection

The configuration input pin CLKSEL selects whether the DS8102 uses the internal 8MHz oscillator or an external clock (provided at CLKIO) when performing conversions. If the internal 8MHz oscillator is selected, the internal clock is driven out at CLKIO and can be used by external devices if desired.

Table 3 summarizes the modes of operation for the DS8102 based on the CLKSEL input. The level at CLKSEL should be set when the DS8102 is in shutdown mode.

## Manchester Encoder

Once the DS8102 enters active mode, it begins generating a Manchester-encoded bit stream on the MNOUT pin. This bit stream is output at a rate equal to the selected clock frequency divided by 4, so, for example, if the internal 8MHz oscillator is selected as the DS8102 clock source, a new bit is output on MNOUT approximately every 500ns.

Bit values are encoded as either low-to-high transitions (for bit values of 1) or high-to-low transitions (for bit values of 0). The transition from low-to-high or high-to-low

occurs halfway through the bit time slot.

As shown in Figure 1, the Manchester-encoded bit-stream output on MNOUT contains three interleaved bit streams. These bit streams, in the order that they are output, are as follows:

- 1) SYNC—Synchronization bit stream containing alternating 0s and 1s.
- 2) CHAN0—Pulse-density-modulated output from analog channel 0.
- 3) CHAN1—Pulse-density-modulated output from analog channel 1.

Both modulator outputs are always included in the bit stream, even if only one of them is being used by the application. This means that the maximum bit-rate output for either modulator channel over MNOUT is  $f_{CLK}/12$  as shown in Figure 1.

## Definitions

### Integral Nonlinearity

Integral nonlinearity (INL) is the deviation of the values on an actual transfer function from a straight line. This straight line is either a best straight-line fit or a line drawn between the endpoints of the transfer function once offset and gain errors have been nullified.

### Offset Error

For an ideal converter, the first transition occurs at 0.5 LSB above zero. Offset error is the amount of deviation between the measured first transition point and the ideal point.

### Power-Supply Rejection Ratio

Power-supply rejection ratio (PSRR) is the ratio of changes in the power supply (V) to changes in the converter output (V). It is typically measured in decibels.

**Table 2. Voltage Reference Selection and Operating Modes**

RST PIN	APDREF PIN	DS8102 MODE
0	X	Shutdown.
1	0	Operation using internal voltage reference (VREF output buffer enabled).
1	1	Operation using external voltage reference (VREF output buffer disabled).

**Table 3. Clock Source Selection**

CLKSEL PIN	DS8102 CLOCK SOURCE	CLKIO PIN MODE
0	Internal 8MHz oscillator	Output: Drives out 8MHz clock.
1	External clock (provided at CLKIO)	Input: Accepts external clock.

# Dual Delta-Sigma Modulator and Encoder

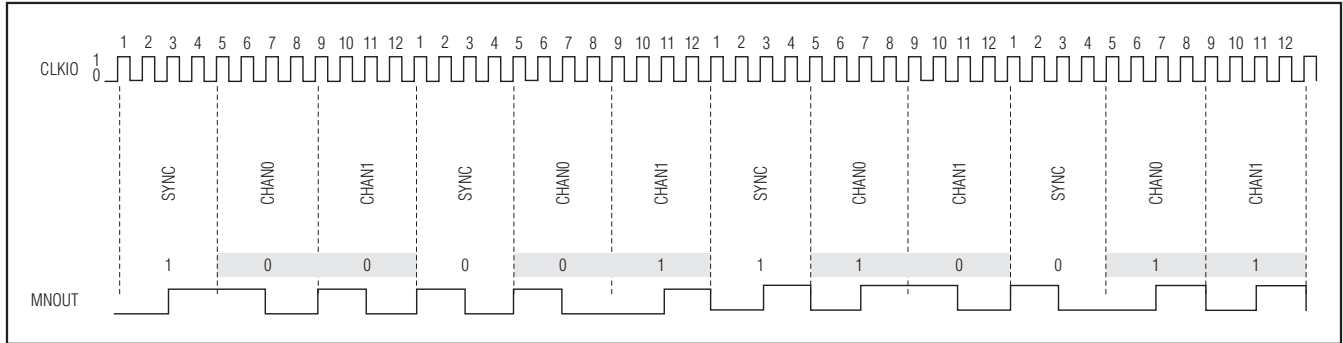
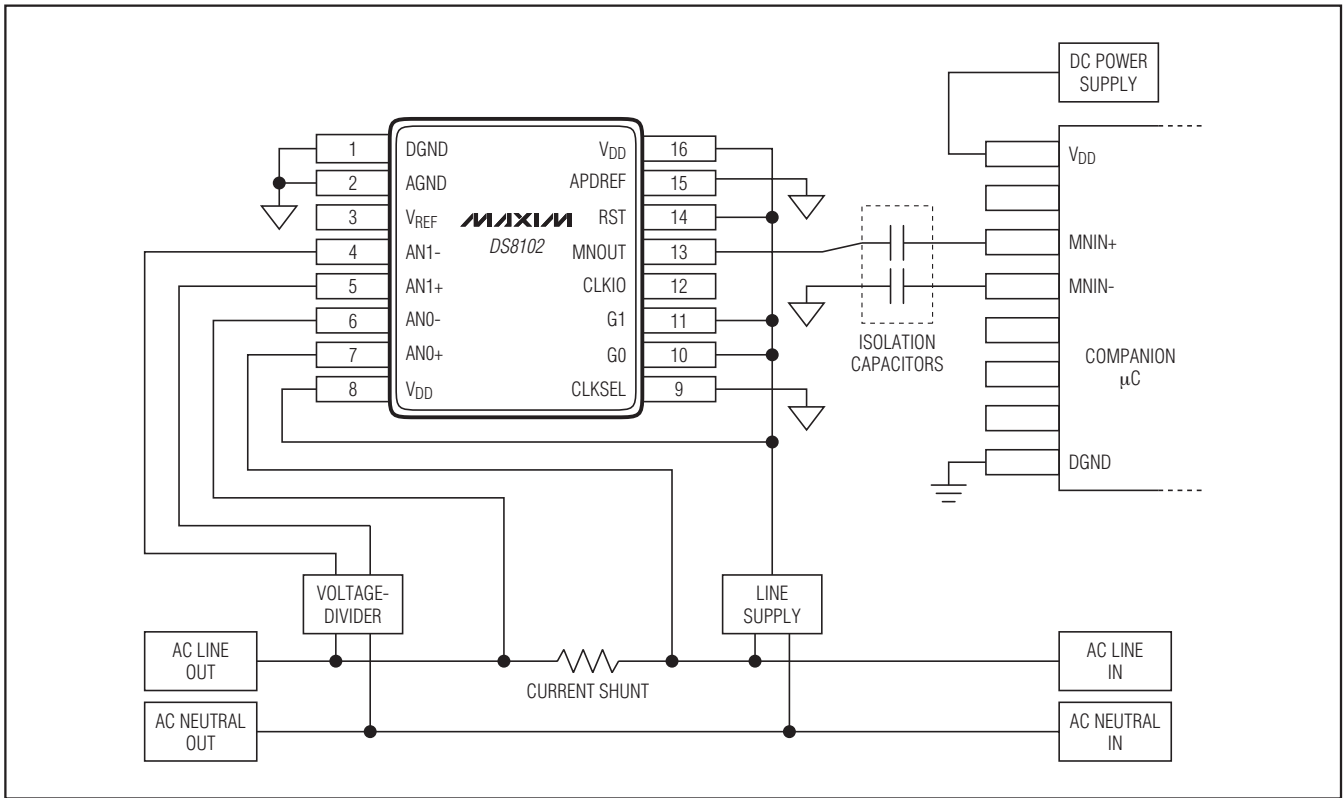

Figure 1. Manchester Encoder Output Example

## Typical Operating Circuit



## Package Information

For the latest package outline information and land patterns, go to [www.maxim-ic.com/packages](http://www.maxim-ic.com/packages).

PACKAGE TYPE	PACKAGE CODE	DOCUMENT NO.
16 TSSOP	U16+2	<a href="#">21-0066</a>

# Dual Delta-Sigma Modulator and Encoder

## Revision History

DS8102



REVISION NUMBER	REVISION DATE	DESCRIPTION	PAGES CHANGED
0	1/09	Initial release.	—
1	2/09	Changed the part number in the <i>Ordering Information</i> table.	1
		In the <i>Electrical Characteristics</i> table, changed $f_{XCLK(MAX)}$ from 12MHz to 8MHz; changed $t_{XCLK-CLCL(MIN)}$ from 83ns to 125ns; changed the Offset Error parameter from 1.4mV (min) to 1.4mV (max); added new conditions and note and changed 1.33MHz (typ) to 0.667MHz (typ) for the Input Sampling Rate parameter.	2, 3
		Corrected the reference from CLKSEL to APDREF in the <i>Internal/External Voltage Reference Selection</i> section; corrected the reference from APDREF to CLKSEL in the <i>Internal/External Clock Selection</i> section.	7

Maxim cannot assume responsibility for use of any circuitry other than circuitry entirely embodied in a Maxim product. No circuit patent licenses are implied. Maxim reserves the right to change the circuitry and specifications without notice at any time.

Maxim Integrated Products, 120 San Gabriel Drive, Sunnyvale, CA 94086 408-737-7600 \_\_\_\_\_ 9

## Looking for pricing, stock, or lifecycle information?

Click below to explore more details on WIN SOURCE:

-  [View DS8102+ on WIN SOURCE](#)
-  [Maxim Integrated Information](#)

## Optimize Your Supply Chain with WIN SOURCE Solutions

-  Global Sourcing Solution
-  Obsolete Management
-  Cost Control Management
-  Shortage Management
-  Alternative Solution
-  Excess Inventory Management