

DS55107/DS75107/DS75108/DS75208 Dual Line Receivers

General Description

The products described herein are TTL compatible dual high speed circuits intended for sensing in a broad range of system applications. While the primary usage will be for line receivers of MOS sensing, any of the products may effectively be used as voltage comparators, level translators, window detectors, transducer preamplifiers, and in other sensing applications. As digital line receivers the products are applicable with the SN55109/SN75109 and μ A75110/DS75110 companion drivers, or may be used in other balanced or unbalanced party-line data transmission systems. The improved input sensitivity and delay specifications of the DS75208 make it ideal for sensing high performance MOS memories as well as high sensitivity line receivers and voltage comparators.

Input protection diodes are incorporated in series with the collectors of the differential input stage. These diodes are

useful in certain applications that have multiple V_{CC+} supplies or V_{CC+} supplies that are turned off.

Features

- Diode protected input stage for power "OFF" condition
- 17 ns typ high speed
- TTL compatible
- ± 10 mV or ± 25 mV input sensitivity
- ± 3 V input common-mode range
- High input impedance with normal V_{CC} , or $V_{CC} = 0$ V
- Strobes for channel selection
- Dual circuits
- Sensitivity gntd. over full common-mode range
- Logic input clamp diodes—meets both "A" and "B" version specifications
- ± 5 V standard supply voltages

Connection Diagram

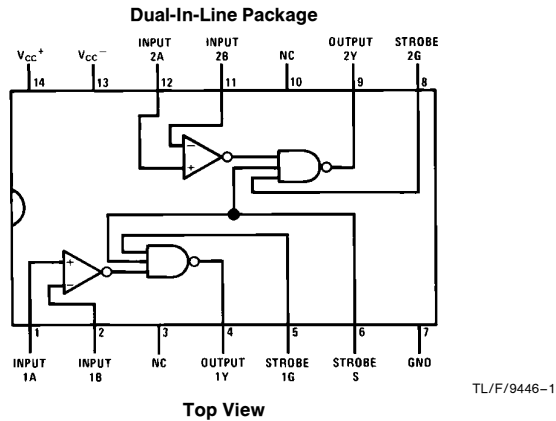

Top View

Order Number DS75107M, DS75107N, DS75107AM, DS75107AN,
DS75108M, DS75108N or DS75208N
See NS Package Number M14A or N14A

For Complete Military 883 Specifications, see RETS Datasheet.
Order Number DS55107AJ/883
See NS Package Number J14A

Selection Guide

Temperature →	$-55^{\circ}\text{C} \leq T_A \leq +125^{\circ}\text{C}$	$0^{\circ}\text{C} \leq T_A \leq +70^{\circ}\text{C}$	
Package →	Cavity Dip	Cavity or Molded Dip	
Input Sensitivity →	± 25 mV	± 25 mV	± 10 mV
Output Logic ↓			
TTL Active Pull-Up	DS55107	DS75107	
TTL Open Collector		DS75108	DS75208

Absolute Maximum Ratings (Note 1)

If Military/Aerospace specified devices are required, please contact the National Semiconductor Sales Office/Distributors for availability and specifications.

Supply Voltage, V_{CC}^+	7V
Supply Voltage, V_{CC}^-	-7V
Differential Input Voltage	$\pm 6V$
Common Mode Input Voltage	$\pm 5V$

Strobe Input Voltage	5.5V
Storage Temperature Range	-65°C to +150°C
Maximum Power Dissipation* at 25°C	
Cavity Package	1308 mW
Molded Package	1207 mW
Lead Temperature (Soldering, 4 sec)	260°C
*Derate cavity package 8.7 mW/°C above 25°C; derate molded package 9.7 mW/°C above 25°C.	

Operating Conditions

	DS55107			DS75107, DS75108, DS75208		
	Min	Nom	Max	Min	Nom	Max
Supply Voltage V_{CC}^+	4.5V	5V	5.5V	4.75V	5V	5.25V
Supply Voltage V_{CC}^-	-4.5V	-5V	-5.5V	-4.75V	-5V	-5.25V
Operating Temperature Range	-55°C	to	+125°C	0°C	to	+70°C

Note 1: "Absolute Maximum Ratings" are those values beyond which the safety of the device cannot be guaranteed. Except for "Operating Temperature Range" they are not meant to imply that the devices should be operated at these limits. The table of "Electrical Characteristics" provides conditions for actual device operation.

Note 2: Unless otherwise specified min/max limits apply across the -55°C to +125°C temperature range for the DS55107 and across the 0°C to +70°C range for the DS75107, DS75108 and DS75208. All typical values are for $T_A = 25^\circ\text{C}$ and $V_{CC} = 5V$.

Note 3: All currents into device pins shown as positive, out of device pins as negative, all voltages referenced to ground unless otherwise noted. All values shown as max or min on absolute value basis.

DS55107/DS75107, DS75108

Electrical Characteristics $T_{MIN} \leq T_A \leq T_{MAX}$ (Notes 2, 3)

Symbol	Parameter	Conditions	Min	Typ	Max	Units
I_{IH}	High Level Input Current into A1, B1, A2 or B2	$V_{CC+} = \text{Max}, V_{CC-} = \text{Max}, V_{ID} = 0.5V, V_{IC} = -3V \text{ to } 3V$		30	75	μA
I_{IL}	Low Level Input Current into A1, B1, A2 or B2	$V_{CC+} = \text{Max}, V_{CC-} = \text{Max}, V_{ID} = -2V, V_{IC} = -3V \text{ to } 3V$			-10	μA
I_{IH}	High Level Input Current into G1 or G2	$V_{CC+} = \text{Max}, V_{CC-} = \text{Max}$			40	μA
		$V_{IH(S)} = 2.4V$			1	mA
		$V_{IH(S)} \text{ Max } V_{CC+}$				
I_{IL}	Low Level Input Current into G1 or G2	$V_{CC+} = \text{Max}, V_{CC-} = \text{Max}, V_{IL(S)} = 0.4V$			-1.6	mA
I_{IH}	High Level Input Current into S	$V_{CC+} = \text{Max}, V_{CC-} = \text{Max}$			80	μA
		$V_{IH(S)} = 2.4V$			2	mA
		$V_{IH(S)} = \text{Max } V_{CC+}$				
I_{IL}	Low Level Input Current into S	$V_{CC+} = \text{Max}, V_{CC-} = \text{Max}, V_{IL(S)} = 0.4V$			-3.2	mA
V_{OH}	High Level Output Voltage	$V_{CC+} = \text{Min}, V_{CC-} = \text{Min}, I_{LOAD} = -400 \mu\text{A}, V_{ID} = 25 \text{ mV}, V_{IC} = -3V \text{ to } 3V, \text{ (Note 3)}$	2.4			V
V_{OL}	Low Level Output Voltage	$V_{CC+} = \text{Min}, V_{CC-} = \text{Min}, I_{SINK} = 16 \text{ mA}, V_{ID} = -25 \text{ mV}, V_{IC} = -3V \text{ to } 3V$			0.4	V
I_{OH}	High Level Output Current	$V_{CC+} = \text{Min}, V_{CC-} = \text{Min}, V_{OH} = \text{Max } V_{CC+}, \text{ (Note 4)}$			250	μA
I_{OS}	Short Circuit Output Current	$V_{CC+} = \text{Max}, V_{CC-} = \text{Max}, \text{ (Notes 2 and 3)}$	-18		-70	mA
I_{CCH+}	High Logic Level Supply Current from V_{CC}	$V_{CC+} = \text{Max}, V_{CC-} = \text{Max}, V_{ID} = 25 \text{ mV}, T_A = 25^\circ\text{C}$		18	30	mA
I_{CCH-}	High Logic Level Supply Current from V_{CC}	$V_{CC+} = \text{Max}, V_{CC-} = \text{Max}, V_{ID} = 25 \text{ mV}, T_A = 25^\circ\text{C}$		-8.4	-15	mA
V_I	Input Clamp Voltage on G or S	$V_{CC+} = \text{Min}, V_{CC-} = \text{Min}, I_{IN} = -12 \text{ mA}, T_A = 25^\circ\text{C}$		-1	-1.5	V

Switching Characteristics $V_{CC+} = 5V, V_{CC-} = -5V, T_A = 25^\circ C$

Symbol	Parameter	Conditions	Min	Typ	Max	Units
$t_{PLH(D)}$	Propagation Delay Time, Low to High Level, from Differential Inputs A and B to Output	$R_L = 390\Omega, C_L = 50\text{ pF}$, (Note 1)	(Note 3)	17	25	ns
			(Note 4)	19	25	ns
$t_{PHL(D)}$	Propagation Delay Time, High to Low Level, from Differential Inputs A and B to Output	$R_L = 390\Omega, C_L = 50\text{ pF}$, (Note 1)	(Note 3)	17	25	ns
			(Note 4)	19	25	ns
$t_{PLH(S)}$	Propagation Delay Time, Low to High Level, from Strobe Input G or S to Output	$R_L = 390\Omega, C_L = 50\text{ pF}$	(Note 3)	10	15	ns
			(Note 4)	13	20	ns
$t_{PHL(S)}$	Propagation Delay Time, High to Low Level, from Strobe Input G or S to Output	$R_L = 390\Omega, C_L = 50\text{ pF}$	(Note 3)	8	15	ns
			(Note 4)	13	20	ns

Note 1: Differential input is +100 mV to -100 mV pulse. Delays read from 0 mV on input to 1.5V on output.

Note 2: Only one output at a time should be shorted.

Note 3: DS55107/DS75107 only.

Note 4: DS75108 only.

DS75208

Electrical Characteristics $0^\circ C \leq T_A \leq +70^\circ C$

Symbol	Parameter	Conditions	Min	Typ	Max	Units
I_{IH}	High Level Input Current into A1, B1, A2 or B2	$V_{CC+} = \text{Max}, V_{CC-} = \text{Max}$, $V_{ID} = 0.5V, V_{IC} = -3V \text{ to } 3V$		30	75	μA
I_{IL}	Low Level Input Current into A1, B1, A2 or B2	$V_{CC+} = \text{Max}, V_{CC-} = \text{Max}$, $V_{ID} = -2V, V_{IC} = -3V \text{ to } 3V$			-10	μA
I_{IH}	High Level Input Current into G1 or G2	$V_{CC+} = \text{Max}$, $V_{CC-} = \text{Max}$	$V_{IH(S)} = 2.4V$		40	μA
			$V_{IH(S)} = \text{Max } V_{CC+}$		1	mA
I_{IL}	Low Level Input Current into G1 or G2	$V_{CC+} = \text{Max}, V_{CC-} = \text{Max}$, $V_{IL(S)} = 0.4V$			-1.6	mA
I_{IH}	High Level Input Current into S	$V_{CC+} = \text{Max}$, $V_{CC-} = \text{Max}$	$V_{IH(S)} = 2.4V$		80	μA
			$V_{IH(S)} = \text{Max } V_{CC+}$		2	mA
I_{IL}	Low Level Input Current into S	$V_{CC+} = \text{Max}, V_{CC-} = \text{Max}$, $V_{IL(S)} = 0.4V$			-3.2	mA
V_{OL}	Low Level Output Voltage	$V_{CC+} = \text{Min}, V_{CC-} = \text{Min}$, $I_{SINK} = 16\text{ mA}, V_{ID} = -10\text{ mV}$, $V_{IC} = -3V \text{ to } 3V$			0.4	V
I_{OH}	High Level Output Current	$V_{CC+} = \text{Min}, V_{CC-} = \text{Min}$, $V_{OH} = \text{Max } V_{CC+}$			250	μA
I_{CCH+}	High Logic Level Supply Current from V_{CC+}	$V_{CC+} = \text{Max}, V_{CC-} = \text{Max}$, $V_{ID} = 10\text{ mV}, T_A = 25^\circ C$		18	30	mA
I_{CCH-}	High Logic Level Supply Current from V_{CC-}	$V_{CC+} = \text{Max}, V_{CC-} = \text{Max}$, $V_{ID} = 10\text{ mV}, T_A = 25^\circ C$		-8.4	-15	mA
V_I	Input Clamp Voltage on G or S	$V_{CC+} = \text{Min}, V_{CC-} = \text{Min}$, $I_{IN} = -12\text{ mA}, T_A = 25^\circ C$		-1	-1.5	V

Switching Characteristics $V_{CC+} = 5V, V_{CC-} = -5V, T_A = 25^\circ C$

Symbol	Parameter	Conditions	Min	Typ	Max	Units
$t_{PLH(D)}$	Propagation Delay Time, Low-to-High Level, from Differential Inputs A and B to Output	$R_L = 470\Omega, C_L = 15\text{ pF}$, (Note 1)			35	ns
$t_{PHL(D)}$	Propagation Delay Time, High-to-Low Level, from Differential Inputs A and B to Output	$R_L = 470\Omega, C_L = 15\text{ pF}$, (Note 1)			20	ns
$t_{PLH(S)}$	Propagation Delay Time, Low-to-High Level, from Strobe Input G or S to Output	$R_L = 470\Omega, C_L = 15\text{ pF}$			17	ns
$t_{PHL(S)}$	Propagation Delay Time, High-to-Low Level, from Strobe Input G or S to Output	$R_L = 470\Omega, C_L = 15\text{ pF}$			17	ns

Note 1: Differential input is +10 mV to -30 mV pulse. Delays read from 0 mV on input to 1.5V on output.

Voltage Waveforms

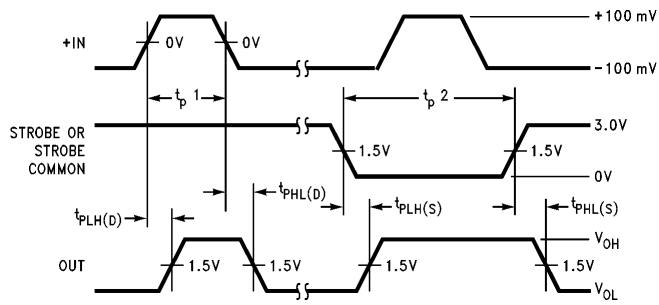

TL/F/9446-12

Typical Applications

Basic Balanced-Line Transmission System

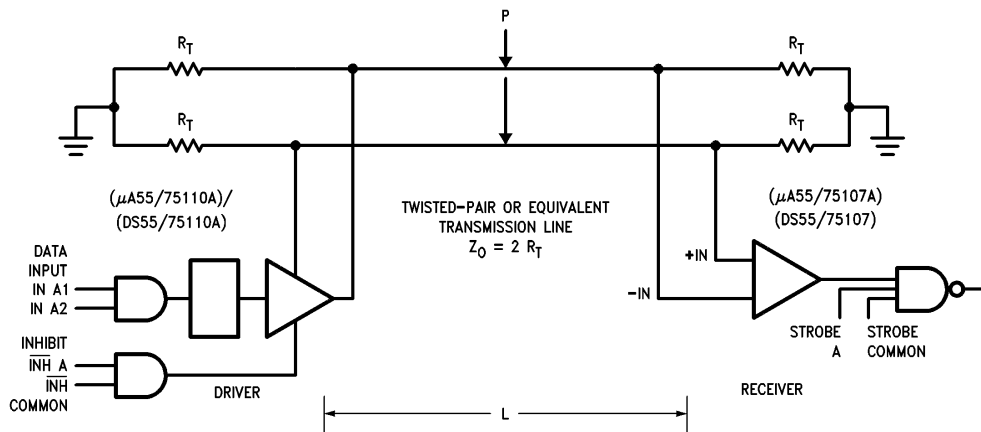

TL/F/9446-2

Typical Applications (Continued)

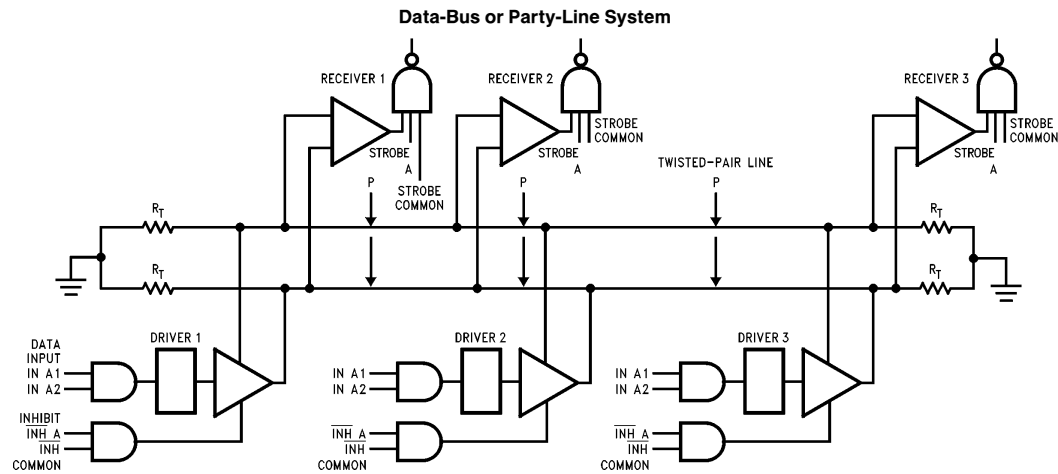

APPLICATION

The DS55107, DS75107 dual line circuits are designed specifically for use in high speed data transmission systems that utilize balanced, terminated transmission lines such as twisted-pair lines. The system operates in the balanced mode, so that noise induced on one line is also induced on the other. The noise appears common mode at the receiver input terminals where it is rejected. The ground connection between the line driver and receiver is not part of the signal circuit so that system performance is not affected by circulating ground currents.

The unique driver output circuit allows terminated transmission lines to be driven at normal line impedances. High speed system operation is ensured since line reflections are virtually eliminated when terminated lines are used. Crosstalk is minimized by low signal amplitudes and low line impedances.

The typical data delay in a system is approximately $(30 + 1.3L)$ ns, where L is the distance in feet separating the driver and receiver. This delay includes one gate delay in both the driver and receiver.

Data is impressed on the balanced-line system by unbalancing the line voltages with the driver output current. The driven line is selected by appropriate driver input logic levels. The voltage difference is approximately:

$$V_{DIFF} \cong \frac{1}{2} I_{O(on)} \times R_T \quad (1)$$

High series line resistance will cause degradation of the signal. The receivers, however, will detect signals as low as

25 mV (or less). For normal line resistances, data may be recovered from lines of several thousand feet in length.

Line termination resistors (R_T) are required only at the extreme ends of the line. For short lines, termination resistors at the receiver only may prove adequate. The signal amplitude will then be approximately:

$$V_{DIFF} \cong I_{O(on)} \times R_T \quad (2)$$

The strobe feature of the receivers and the inhibit feature of the drivers allow the DS55107, DS75107 dual line circuits to be used in data-bus or party-line systems. In these applications, several drivers and receivers may share a common transmission line. An enabled driver transmits data to all enabled receivers on the line while other drivers and receivers are disabled. Data is thus time multiplexed on the transmission line. The DS55107, DS75107 device specifications allow widely varying thermal and electrical environments at the various driver and receiver locations. The data-bus system offers maximum performance at minimum cost.

The DS55107, DS75107 dual line circuits may also be used in unbalanced or single line systems. Although these systems do not offer the same performance as balanced systems for long lines, they are adequate for very short lines where environment noise is not severe.

The receiver threshold level is established by applying a DC reference voltage to one receiver input terminal. The signal from the transmission line is applied to the remaining input. The reference voltage should be optimized so that signal

Typical Applications (Continued)

swing is symmetrical about it for maximum noise margin. The reference voltage should be in the range of $-3.0V$ to $+3.0V$. It can be provided by a voltage supply or by a voltage divider from an available supply voltage.

Unbalanced or Single-Line Systems

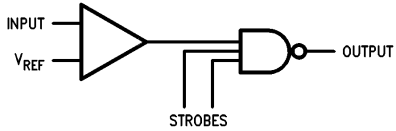

TL/F/9446-4

Precautions in the Use of DS1603, DS3603, DS55107, DS75107, DS75108 and DS75208 Dual Line Receivers

The following precaution should be observed when using or testing DS55107, DS75107 line circuits.

When only one receiver in a package is being used, at least one of the differential inputs of the unused receiver should be terminated at some voltage between $-3.0V$ and $+3.0V$, preferably at ground. Failure to do so will cause improper operation of the unit being used because of common bias circuitry for the current sources of the two receivers.

The DS55107, DS75107 and DS75108 line receivers feature a common mode input voltage range of $\pm 3.0V$. This satisfies the requirements for all but the noisiest system applications. For these severe noise environments, the common mode range can be extended by the use of external input attenuators. Common mode input voltages can in this way be reduced to $\pm 3.0V$ at the receiver input terminals. Differential data signals will be reduced proportionately. Input sensitivity, input impedance and delay times will be adversely affected.

The DS75108 line receivers feature an open-collector-output circuit that can be connected in the DOT-OR logic configuration with other DS75108 outputs. This allows a level of logic to be implemented without additional logic delay.

Increasing Common Mode Input Voltage Range of Receiver

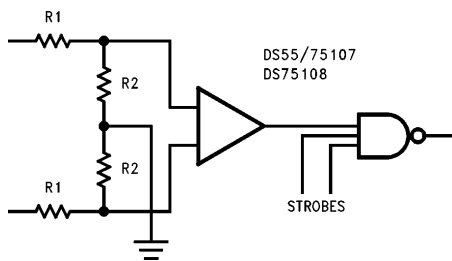

TL/F/9446-5

DS75108 Wired-OR Output Connections

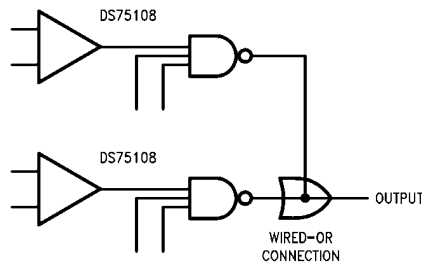

TL/F/9446-6

Circuit Differences Between "A" and Standard Devices

The difference between the "A" and standard devices is shown in the following schematics of the input stage.

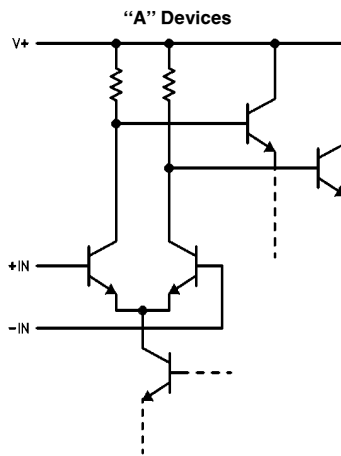

TL/F/9446-7

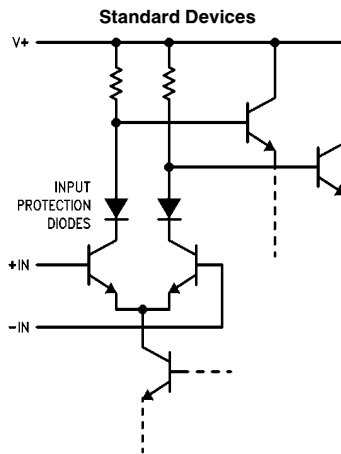

TL/F/9446-8

Typical Applications (Continued)

The input protection diodes are useful in certain party-line systems which may have multiple $V+$ power supplies and, in which case, may be operated with some of the $V+$ supplies turned off. In such a system, if a supply is turned off and allowed to go to ground, the equivalent input circuit connected to that supply would be as follows:

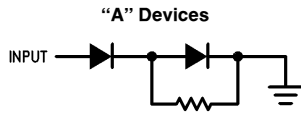

TL/F/9446-9

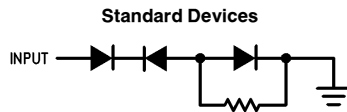

TL/F/9446-10

This would be a problem in specific systems which might possibly have the transmission lines biased to some potential greater than 1.4V. Since this is not a widespread application problem, both the "A" and standard devices will be available. The ratings and characteristic specifications of the "A" devices are the same as those of the standard devices.

The DS55107A feature the "A" device input stage.

Schematic Diagrams

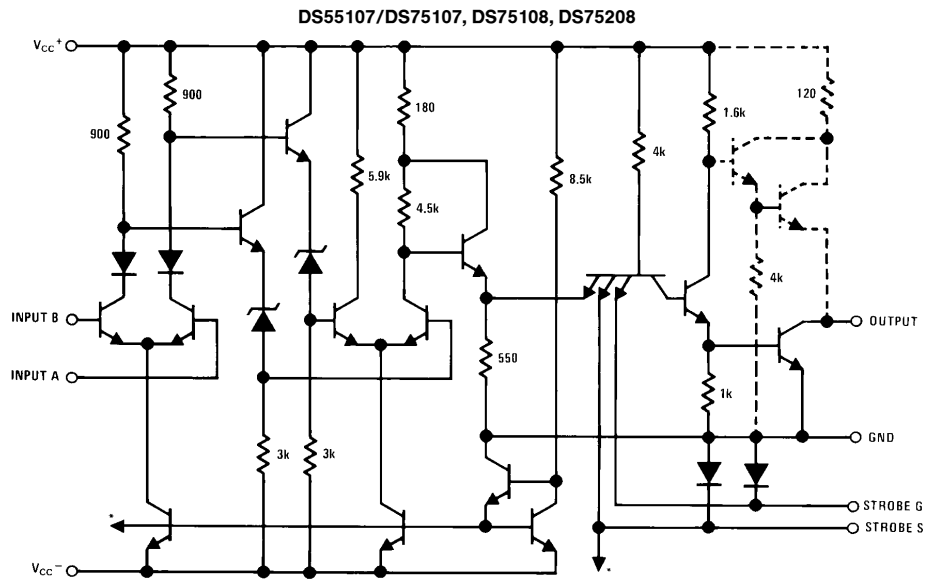

TL/F/9446-11

Note 1: $\frac{1}{2}$ of the dual circuit is shown.

Note 2: *Indicates connections common to second half of dual circuit.

Note 3: Components shown with dash lines are applicable to the DS55107, DS75207 and DS75107 only.

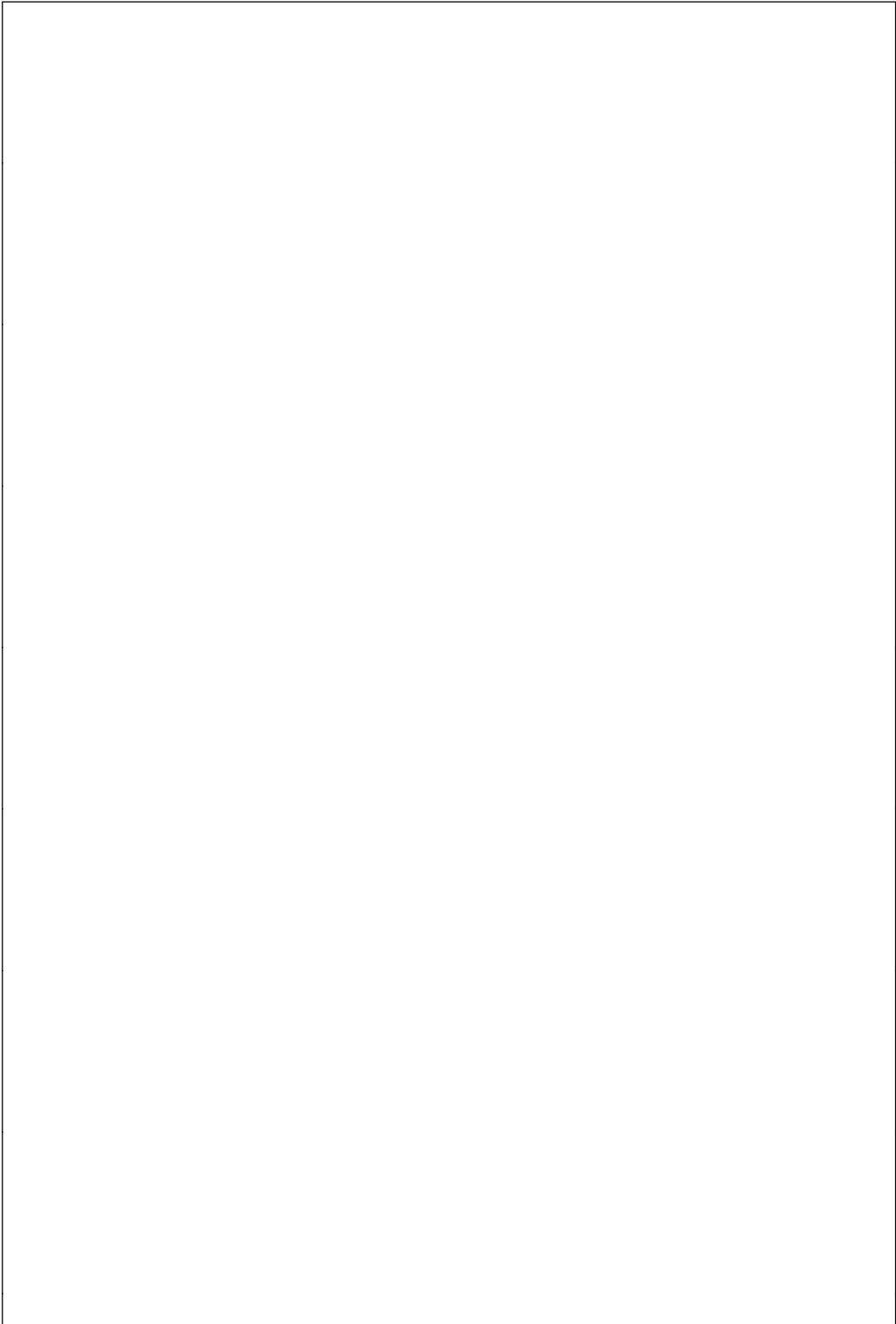

Physical Dimensions inches (millimeters)

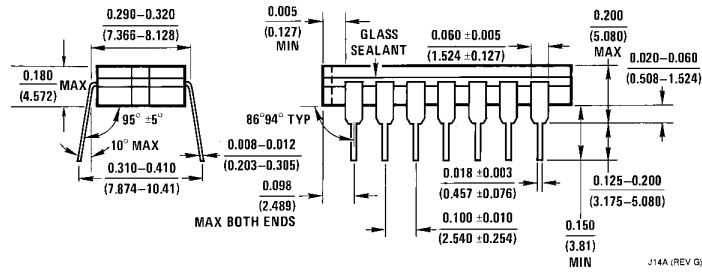
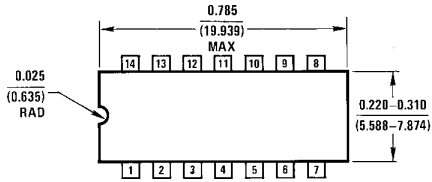

Ceramic Dual-In-Line Package (J)
Order Number DS55107J, DS75107J or DS75208J
NS Package Number J14A

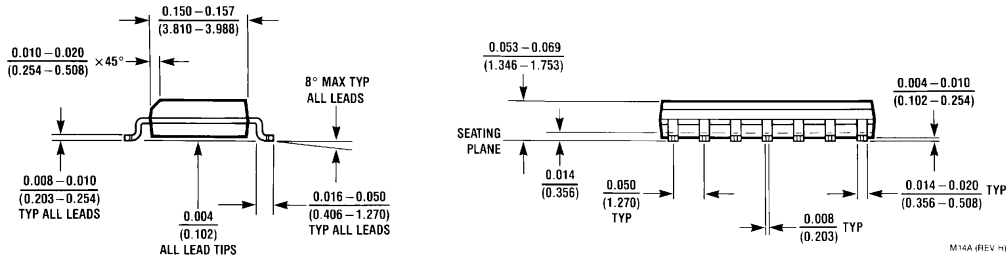
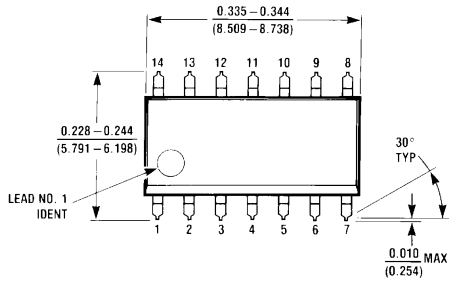

Molded Dual-In-Line Package (M)
Order Number DS75107M, DS75107AM or DS75108M
NS Package Number M14A

Physical Dimensions inches (millimeters) (Continued)

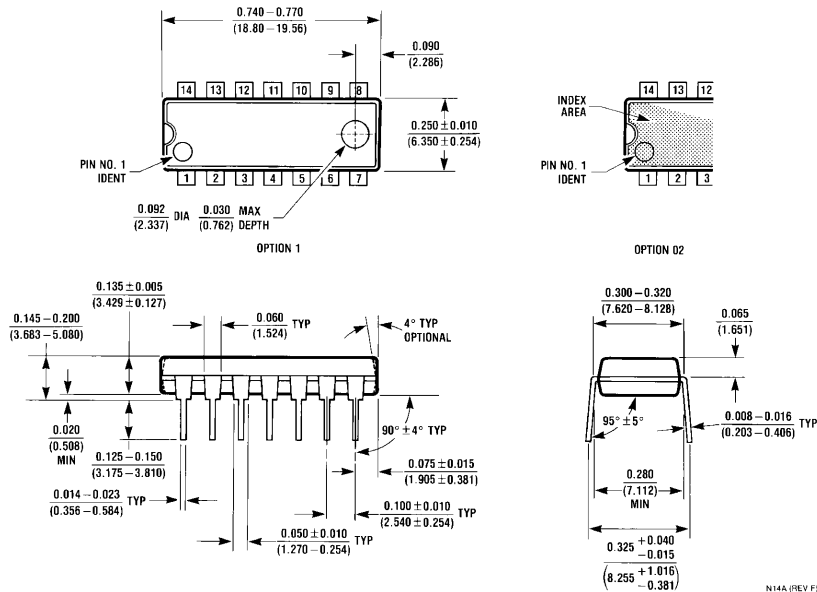

Molded Dual-In-Line Package (N)
Order Number DS75107N, DS75107AN, DS75108N or DS75208N
NS Package Number N14A

N14A (REV F)

LIFE SUPPORT POLICY

NATIONAL'S PRODUCTS ARE NOT AUTHORIZED FOR USE AS CRITICAL COMPONENTS IN LIFE SUPPORT DEVICES OR SYSTEMS WITHOUT THE EXPRESS WRITTEN APPROVAL OF THE PRESIDENT OF NATIONAL SEMICONDUCTOR CORPORATION. As used herein:

1. Life support devices or systems are devices or systems which, (a) are intended for surgical implant into the body, or (b) support or sustain life, and whose failure to perform, when properly used in accordance with instructions for use provided in the labeling, can be reasonably expected to result in a significant injury to the user.
2. A critical component is any component of a life support device or system whose failure to perform can be reasonably expected to cause the failure of the life support device or system, or to affect its safety or effectiveness.



National Semiconductor Corporation
 1111 West Bardin Road
 Arlington, TX 76017
 Tel: 1(800) 272-9959
 Fax: 1(800) 737-7018

<http://www.national.com>

National Semiconductor Europe

Fax: +49 (0) 180-530 85 86
 Email: europe.support@nsc.com
 Deutsch Tel: +49 (0) 180-530 85 85
 English Tel: +49 (0) 180-532 78 32
 Français Tel: +49 (0) 180-532 93 58
 Italiano Tel: +49 (0) 180-534 16 80

National Semiconductor Hong Kong Ltd.

19th Floor, Straight Block,
 Ocean Centre, 5 Canton Rd.
 Tsimshatsui, Kowloon
 Hong Kong
 Tel: (852) 2737-1600
 Fax: (852) 2736-9960

National Semiconductor Japan Ltd.

Tel: 81-043-299-2308
 Fax: 81-043-299-2408

National does not assume any responsibility for use of any circuitry described, no circuit patent licenses are implied and National reserves the right at any time without notice to change said circuitry and specifications.

Looking for pricing, stock, or lifecycle information?

Click below to explore more details on WIN SOURCE:

 [View DS75107BN on WIN SOURCE](#)

 [Texas Instruments](#) Information

Optimize Your Supply Chain with WIN SOURCE Solutions

-  Global Sourcing Solution
-  Obsolete Management
-  Cost Control Management
-  Shortage Management
-  Alternative Solution
-  Excess Inventory Management