



**THE DATASHEET OF  
DS32KHZN/DIP#**



# DS32kHz 32.768kHz Temperature-Compensated Crystal Oscillator

[www.maxim-ic.com](http://www.maxim-ic.com)

## GENERAL DESCRIPTION

The DS32kHz is a temperature-compensated crystal oscillator (TCXO) with an output frequency of 32.768kHz. This device addresses applications requiring better timekeeping accuracy, and can be used to drive the X1 input of most Dallas Semiconductor real-time clocks (RTCs), chipsets, and other ICs containing RTCs. This device is available in commercial (DS32kHz) and industrial (DS32kHz-N) temperature versions.

## APPLICATIONS

- GPS Receivers
- Telematics
- Network Timing and Synchronization in Servers, Routers, Hubs, and Switches
- Automatic Power Meters

## FEATURES

- Accurate to  $\pm 4$  Minutes/Year ( $-40^{\circ}\text{C}$  to  $+85^{\circ}\text{C}$ )
- Accurate to  $\pm 1$  Minute/Year ( $0^{\circ}\text{C}$  to  $+40^{\circ}\text{C}$ )
- Battery Backup for Continuous Timekeeping
- $V_{\text{BAT}}$  Operating Voltage: 2.7V to 5.5V with  $V_{\text{CC}}$  Grounded
- $V_{\text{CC}}$  Operating Voltage: 4.5V to 5.5V
- Operating Temperature Range:
  - $0^{\circ}\text{C}$  to  $+70^{\circ}\text{C}$  (Commercial)
  - $-40^{\circ}\text{C}$  to  $+85^{\circ}\text{C}$  (Industrial)
- No Calibration Required
- Low-Power Consumption
- Surface Mountable Using BGA Package
- UL Recognized

## ORDERING INFORMATION

PART	TEMP RANGE	PIN-PACKAGE	TOP MARK*
DS32KHZ/DIP	$0^{\circ}\text{C}$ to $+70^{\circ}\text{C}$	14 DIP	DS32KHZ
DS32KHZN/DIP	$-40^{\circ}\text{C}$ to $+85^{\circ}\text{C}$	14 DIP	DS32KHZ-N
DS32KHZS	$0^{\circ}\text{C}$ to $+70^{\circ}\text{C}$	16 SO (0.300")	DS32KHZS
DS32KHZS#	$0^{\circ}\text{C}$ to $+70^{\circ}\text{C}$	16 SO (0.300")	DS32KHZS
DS32KHZSN	$-40^{\circ}\text{C}$ to $+85^{\circ}\text{C}$	16 SO (0.300")	DS32KHZSN
DS32KHZSN#	$-40^{\circ}\text{C}$ to $+85^{\circ}\text{C}$	16 SO (0.300")	DS32KHZSN
DS32KHZ/WBGA+	$0^{\circ}\text{C}$ to $+70^{\circ}\text{C}$	36 BGA	DS32KHZ
DS32KHZN/WBGA+	$-40^{\circ}\text{C}$ to $+85^{\circ}\text{C}$	36 BGA	DS32KHZ-N

#Denotes a RoHS-compliant device that may include lead that is exempt under the RoHS requirements. The lead finish is JESD97 category e3, and is compatible with both lead-based and lead-free soldering processes.  
\*A “#” anywhere on the top mark denotes a RoHS-compliant device. An “N” denotes an industrial device.

## PIN CONFIGURATIONS

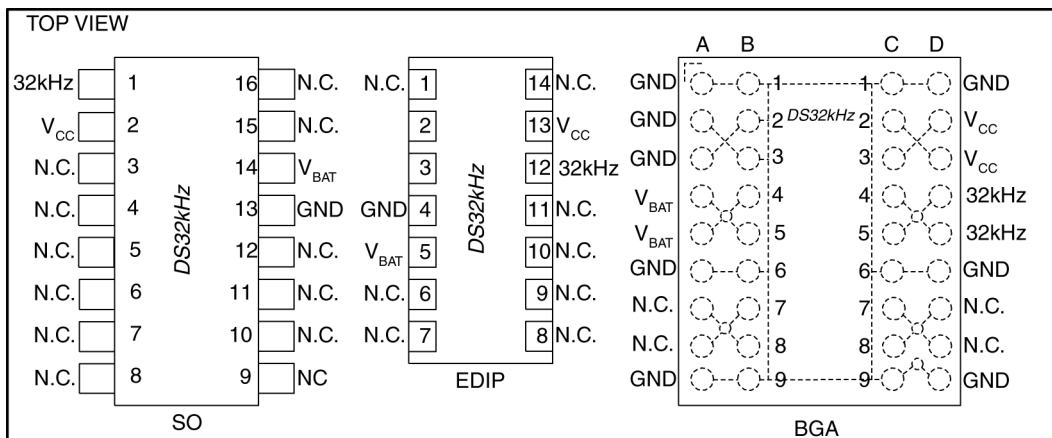

## ABSOLUTE MAXIMUM RATINGS

Voltage Range on Any Pin Relative to Ground.....	-3.0V to +7.0V
Operating Temperature Range (Noncondensing)	
Commercial:.....	0°C to +70°C
Industrial:.....	-40°C to +85°C
Storage Temperature Range.....	-40°C to +85°C
Soldering Temperature (BGA, SO).....	See the <i>Handling, PC Board Layout, and Assembly</i> section.
Soldering Temperature, Leads (DIP).....	+260°C for 10 seconds ( <b>Note 1</b> )

Stresses beyond those listed under "Absolute Maximum Ratings" may cause permanent damage to the device. These are stress ratings only, and functional operation of the device at these or any other conditions beyond those indicated in the operational sections of the specifications is not implied. Exposure to the absolute maximum rating conditions for extended periods may affect device reliability.

## RECOMMENDED DC OPERATING CONDITIONS

( $T_A = -40^\circ\text{C}$  to  $+85^\circ\text{C}$ ) (Note 1)

PARAMETER	SYMBOL	CONDITIONS	MIN	TYP	MAX	UNITS
Power-Supply Voltage	$V_{CC}$	(Note 2)	4.5	5.0	5.5	V
Battery Voltage	$V_{BAT}$	(Notes 2, 3)	2.7	3.0	3.5, 5.5	V

## DC ELECTRICAL CHARACTERISTICS

(Over the operating range, unless otherwise specified.) (Note 1)

PARAMETER	SYMBOL	CONDITIONS	MIN	TYP	MAX	UNITS
Active Supply Current	$I_{CC}$	$V_{BAT} = 0\text{V}$ or $2.7\text{V} \leq V_{BAT} \leq 3.5\text{V}$ (Notes 3, 4)		150	220	$\mu\text{A}$
Battery Input-Leakage Current	$I_{BATLKG}$	$V_{CC\text{ MIN}} \leq V_{CC} \leq V_{CC\text{ MAX}}$	-50		+50	nA
High Output Voltage ( $V_{CC}$ )	$V_{OH}$	$I_{OH} = -1.0\text{mA}$ (Note 2)	2.4			V
Low Output Voltage	$V_{OL}$	$I_{OL} = 2.1\text{mA}$ (Note 2)			0.4	V
High Output Voltage ( $V_{BAT}$ )	$V_{OH}$	$I_{OH} = -0.1\text{mA}$ (Note 2)	2.4			V
Battery Switch Voltage	$V_{SW}$	(Note 2)		$V_{BAT}$		V

( $V_{CC} = 0\text{V}$ ,  $T_A = -40^\circ\text{C}$  to  $+85^\circ\text{C}$ .) (Note 1)

PARAMETER	SYMBOL	CONDITIONS	MIN	TYP	MAX	UNITS
Active Battery Current	$I_{BAT}$	$V_{BAT} = 3.3\text{V}$ (Notes 4, 5, 6)		1	4	$\mu\text{A}$
Battery Current During Temperature Measurement	$I_{BATCNV}$	$V_{BAT} = 3.3\text{V}$ (Notes 4, 5, 7)		450		$\mu\text{A}$

**Note 1:** Limits at  $-40^\circ\text{C}$  are guaranteed by design and are not production tested.

**Note 2:** All voltages are referenced to ground.

**Note 3:**  $V_{BAT}$  must be no greater than 3.5V when the device is used in the dual-supply operating modes.

**Note 4:** Typical values are at  $+25^\circ\text{C}$  and 5.0V  $V_{CC}$ , 3.0  $V_{BAT}$ , unless otherwise indicated.

**Note 5:** These parameters are measured under no output load conditions.

**Note 6:** This current is the active-mode current sourced from the backup supply/battery.

**Note 7:** A temperature conversion lasts 122ms (typ) and occurs on power-up and then once every 64 seconds.

## AC TIMING CHARACTERISTICS

(Over the operating range, unless otherwise specified.)

PARAMETER	SYMBOL	CONDITIONS	MIN	TYP	MAX	UNITS
Output Frequency	$f_{OUT}$			32.768		kHz
Frequency Stability vs. Temperature	$\Delta f/f_0$	0°C to +40°C	-2.0		+2.0	ppm
		Industrial Device (N): -40°C to +85°C Commercial Device: 0°C to +70°C	-7.5		+7.5	
Duty Cycle	$t_W/t$		45	50	55	%
Cycle Time	$t_{CYC}$	(Note 8)		30.518		$\mu$ s
High/Low Time	$t_H/t_L$	(Note 8)		15.06		$\mu$ s
Rise Time	$t_R$	(Note 8)		200		ns
Fall Time	$t_F$	(Note 8)		60		ns
Oscillator Startup Time	$t_{OSC}$	(Note 8)		1		seconds
Frequency Stability vs. Operating Voltage	$\Delta f/V$	$V_{CC} = 5.0V$ or $V_{BAT} = 3.0V, V_{CC} = 0V$ (Notes 4, 9)		+2.5		ppm/v
Crystal Aging (First Year)	$\Delta f/f_0$	(Notes 4, 10)		$\pm 1.0$		ppm

**Note 8:** These parameters are measured using a 15pF load.

**Note 9:** Error is measured from the nominal supply voltage of whichever supply is powering the device.

**Note 10:** After reflow.

**Figure 1. DS32kHz Output Waveform**

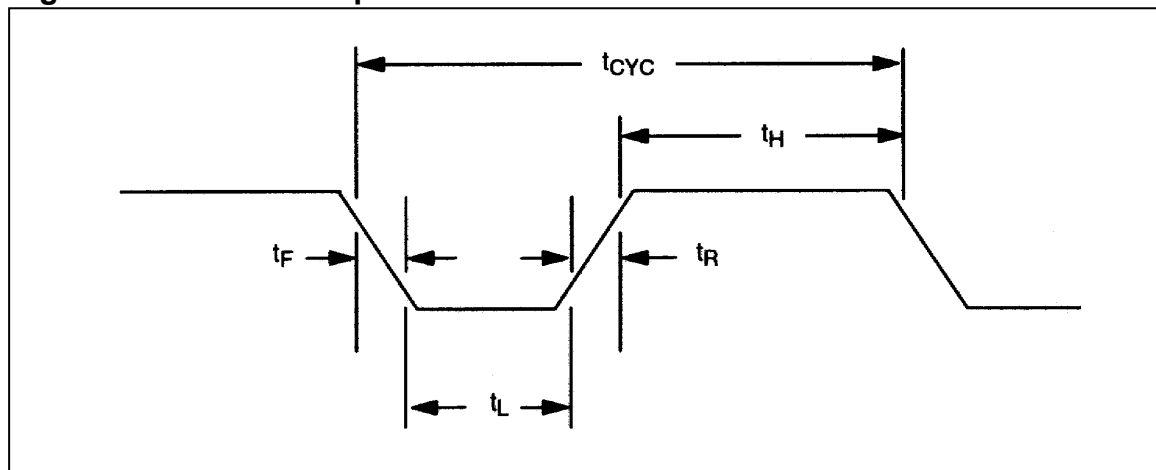

## TYPICAL OPERATING CHARACTERISTICS

( $V_{CC} = 3.3V$ ,  $T_A = +25^\circ C$ , unless otherwise noted.)

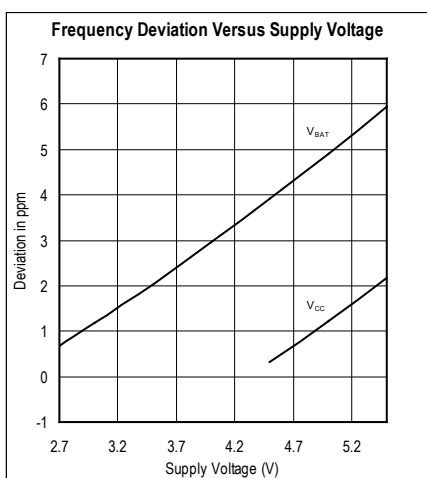
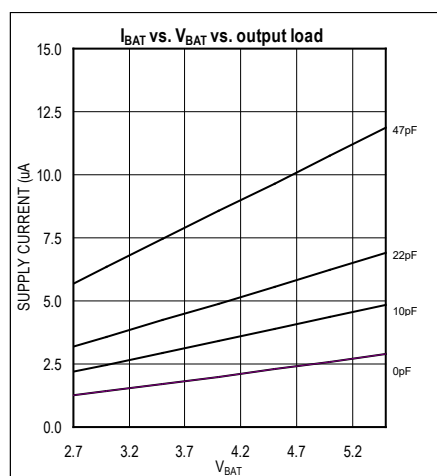
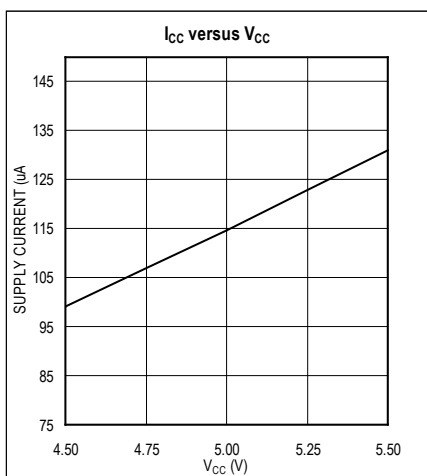
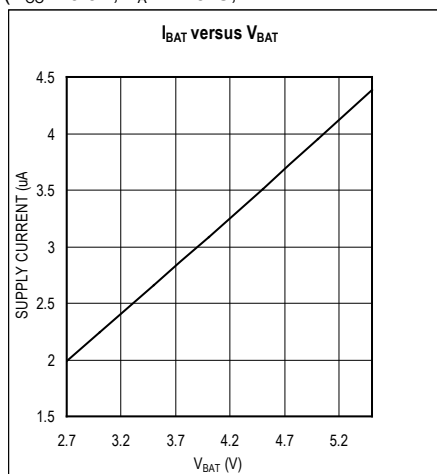

## PIN DESCRIPTION

PIN			NAME	FUNCTION
SO	BGA	DIP		
1	C4, C5, D4, D5	12	32kHz	32.768kHz Push-Pull Output
2	C2, C3, D2, D3	13	V <sub>CC</sub>	Primary Power Supply
3–12, 15, 16	A7, A8, B7, B8, C7, C8, D7, D8	1, 6–11, 14	N.C.	No Connection (Must be grounded)
13	All remaining balls	4	GND	Ground
14	A4, A5, B4, B5	5	V <sub>BAT</sub>	+3V Nominal Supply Input. Used to operate the device when V <sub>CC</sub> is absent.

Figure 2. Delta Time and Frequency vs. Temperature

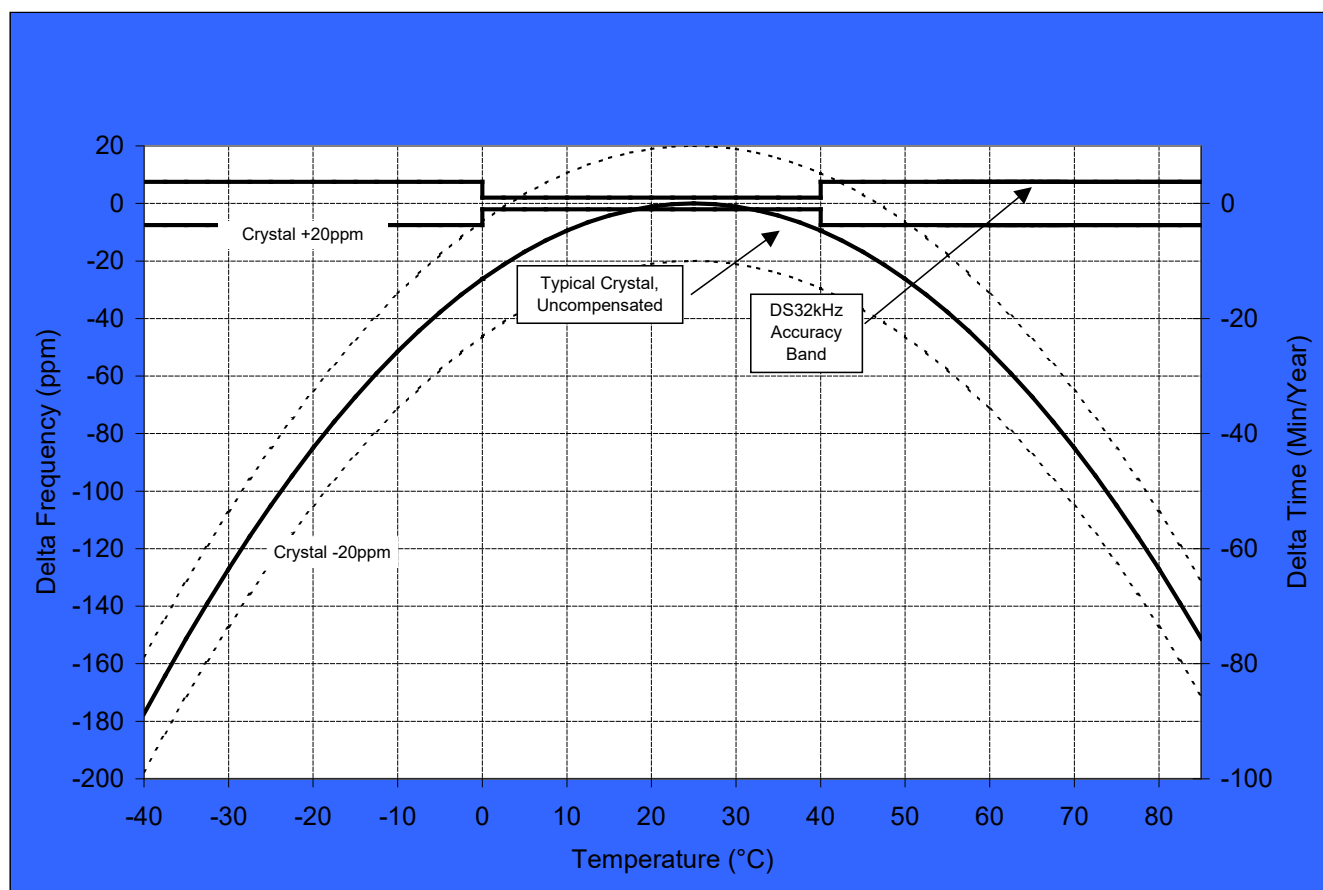

## FUNCTIONAL DESCRIPTION

The DS32kHz is a temperature-compensated crystal oscillator (TCXO) that outputs a 32,768Hz square wave. While the DS32kHz is powered by either supply input, the device measures the temperature every 64 seconds and adjusts the output frequency. The device requires four pins for operation: V<sub>CC</sub>, GND, V<sub>BAT</sub>, and 32kHz. (See [Figure 4](#) for connection schemes.) Power is applied through V<sub>CC</sub> and GND, while V<sub>BAT</sub> is used to maintain the 32kHz output in the absence of power. Once every 64 seconds, the DS32kHz measures the temperature and adjusts the output frequency. The output is accurate to  $\pm 2$ ppm ( $\pm 1$  min/yr) from 0°C to +40°C and to  $\pm 7.5$ ppm ( $\pm 4$  min/year) from -40°C to 0°C and from +40°C to +85°C.

The DS32kHz is packaged in a 36-pin ball grid array (BGA). It also is available in a 16-pin 0.300" SO and a 14-pin encapsulated DIP (EDIP) module.

The additional PC board space required to add the DS32kHz as an option for driving a RTC is negligible in many applications (see [Figure 6](#)). Therefore, adding the DS32kHz to new designs and future board revisions allows the use of the DS32kHz where applications require improved timekeeping accuracy.

**Figure 3. Block Diagram**

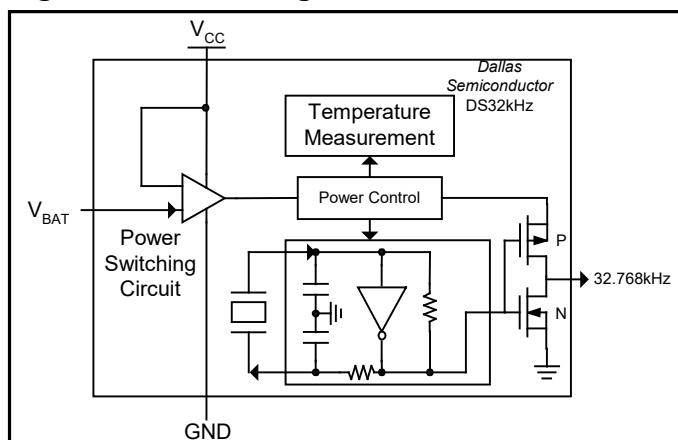

## OPERATION

The DS32kHz module contains a quartz tuning-fork crystal and an IC. When power is first applied, and when the device switches between supplies, the DS32kHz measures the temperature and adjusts the crystal load to compensate the frequency. The power supply must remain at a valid level whenever a temperature measurement is made, including when  $V_{CC}$  is first applied. While powered, the DS32kHz measures the temperature once every 64 seconds and adjusts the crystal load.

The DS32kHz is designed to operate in two modes. In the dual-supply mode, a comparator circuit, powered by  $V_{CC}$ , monitors the relationship between the  $V_{CC}$  and  $V_{BAT}$  input levels. When  $V_{CC}$  drops below a certain level compared to  $V_{BAT}$ , the device switches over to  $V_{BAT}$  ([Figure 4A](#)). This mode uses  $V_{CC}$  to conserve the battery connected to  $V_{BAT}$  while  $V_{CC}$  is applied.

In the single-supply mode,  $V_{CC}$  is grounded and the unit is powered by  $V_{BAT}$ . Current consumption is less than  $V_{CC}$ , because the comparator circuit is unpowered ([Figure 4B](#)).

[Figure 4A](#) shows how the DS32kHz should be connected when using two power supplies.  $V_{CC}$  should be between 4.5V and 5.5V, and  $V_{BAT}$  should be between 2.7V and 3.5V. [Figure 4B](#) shows how the DS32kHz can be used when only a single-supply system is available.  $V_{CC}$  should be grounded and  $V_{BAT}$  should then be held between 2.7V and 5.5V. The  $V_{BAT}$  pin should be connected directly to a battery. [Figure 4C](#) shows a single-supply mode where  $V_{CC}$  is held at +5V. See the frequency stability vs. operating voltage for information about frequency error vs. supply voltage.

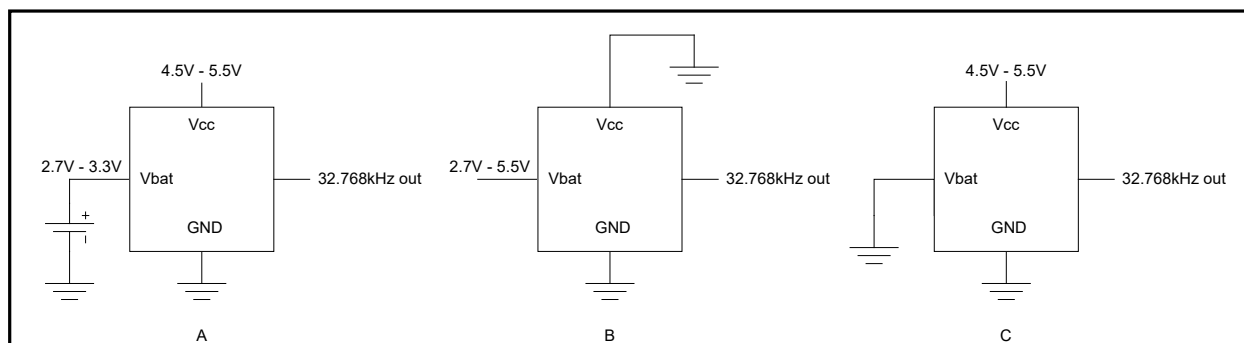
**Figure 4. Power-Supply Connections**

[Figure 5](#) illustrates how a standard 32.768kHz crystal and the DS32kHz should be connected to address the interchangeable option. Using this connection scheme and the recommended layout provides a solution, which requires no hardware modifications. Only one device should be used at a time, and both layouts should be located very close together if the recommended layout is not used.

The DS32kHz  $I_{CC}$  and  $I_{BAT}$  currents are specified with no output loads. Many RTC oscillator circuits use a quartz crystal or resonator. Driving the oscillator circuit with the rail-to-rail output of the DS32kHz can increase the  $I_{CC}$  and  $I_{BAT}$  currents significantly and increase the current consumption of the RTC as well. [Figure 6](#) shows one circuit that can be used to reduce the current consumption of a DS32kHz and an RTC. The values of R1 and C1 may vary depending on the RTC used. However, values of  $1.0M\Omega$  and  $100pF$  are recommended as a starting point. R2 is used to shift the input waveform to the proper level. The recommended value for R2 is  $33k\Omega$ .

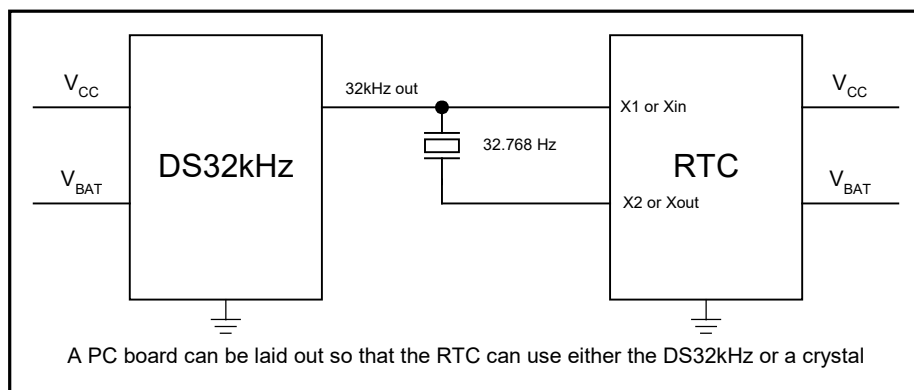
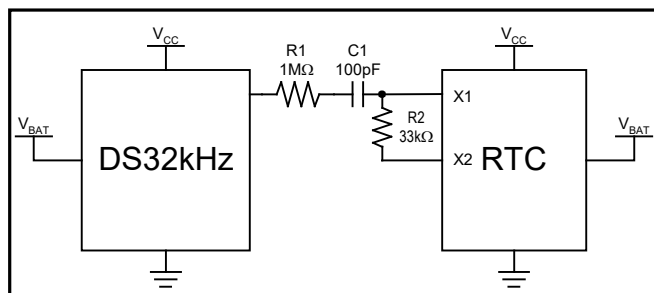
**Figure 5. DS32kHz Connections****Figure 6. DS32kHz and RTC Connections**

## RELATED APPLICATION NOTES

(Go to [www.maxim-ic.com/RTCapps](http://www.maxim-ic.com/RTCapps) to find these application notes and more.)

*Application Note 58: Crystal Considerations with Dallas Real-Time Clocks*

*Application Note 701: Using the DS32kHz with Dallas RTCs*

## HANDLING, PC BOARD LAYOUT, AND ASSEMBLY

These packages contain a quartz tuning-fork crystal. Pick-and-place equipment may be used, but precautions should be taken to ensure that excessive shocks are avoided. Ultrasonic cleaning should be avoided to prevent damage to the crystal.

Avoid running signal traces under the package, unless a ground plane is placed between the package and the signal line. All N.C. (no connect) pins must be connected to ground.

The BGA package may be reflowed as long as the peak temperature does not exceed +225°C. Peak reflow temperature ( $\geq 220^\circ\text{C}$ ) duration should not exceed 10 seconds, and the total time above 200°C should not exceed 40 seconds (30 seconds nominal). For the SO package, refer to the IPC/JEDEC J-STD-020 specification for reflow profiles. Exposure to reflow is limited to 2 times maximum. The DIP package can be wave-soldered, provided that the internal crystal is not exposed to temperatures above +150°C.

Moisture sensitive packages are shipped from the factory dry-packed. Handling instructions listed on the package label must be followed to prevent damage during reflow. Refer to the IPC/JEDEC J-STD-020 standard for moisture-sensitive device (MSD) classifications.

## THERMAL INFORMATION

PACKAGE TYPE	THETA-J <sub>A</sub> (°C/W)	THETA-J <sub>C</sub> (°C/W)
16-pin SO (300 mils)	73	23
36-pin BGA	43.9	18.4



## PACKAGE INFORMATION

(For the latest package information, go to [www.maxim-ic.com/DallasPackInfo](http://www.maxim-ic.com/DallasPackInfo).)

PACKAGE TYPE	DOCUMENT NO.
14-pin Encapsulated DIP	<a href="#">56-G0001-002</a>
16-pin SO (300 mils)	<a href="#">56-G4009-001</a>
36-pin BGA	<a href="#">56-G6023-001</a>

## Looking for pricing, stock, or lifecycle information?

Click below to explore more details on WIN SOURCE:

-  [View DS32KHZN/DIP# on WIN SOURCE](#)
-  [Maxim Integrated Information](#)

## Optimize Your Supply Chain with WIN SOURCE Solutions

-  Global Sourcing Solution
-  Obsolete Management
-  Cost Control Management
-  Shortage Management
-  Alternative Solution
-  Excess Inventory Management