



**THE DATASHEET OF
DS3172+**



DS3171/DS3172/DS3173/DS3174

Single/Dual/Triple/Quad DS3/E3 Single-Chip Transceivers

www.maxim-ic.com

GENERAL DESCRIPTION

The DS3171, DS3172, DS3173, and DS3174 (DS317x) combine a DS3/E3 framer(s) and LIU(s) to interface to as many as four DS3/E3 physical copper lines.

APPLICATIONS

Access Concentrators	Multiservice Access Platform (MSAP)
SONET/SDH ADM and Muxes	Multiservice Protocol Platform (MSPP)
PBXs	PDH Multiplexer/Demultiplexer
Digital Cross Connect Test Equipment	Integrated Access Device (IAD)

ORDERING INFORMATION

PART	TEMP RANGE	PIN-PACKAGE
DS3171	0°C to +70°C	400 TE-PBGA (27mm x 27mm, 1.27mm pitch)
DS3171N	-40°C to +85°C	400 TE-PBGA (27mm x 27mm, 1.27mm pitch)
DS3172	0°C to +70°C	400 TE-PBGA (27mm x 27mm, 1.27mm pitch)
DS3172N	-40°C to +85°C	400 TE-PBGA (27mm x 27mm, 1.27mm pitch)
DS3173	0°C to +70°C	400 TE-PBGA (27mm x 27mm, 1.27mm pitch)
DS3173N	-40°C to +85°C	400 TE-PBGA (27mm x 27mm, 1.27mm pitch)
DS3174	0°C to +70°C	400 TE-PBGA (27mm x 27mm, 1.27mm pitch)
DS3174N	-40°C to +85°C	400 TE-PBGA (27mm x 27mm, 1.27mm pitch)

Note: Add the "+" suffix for the lead-free package option.

FUNCTIONAL DIAGRAM

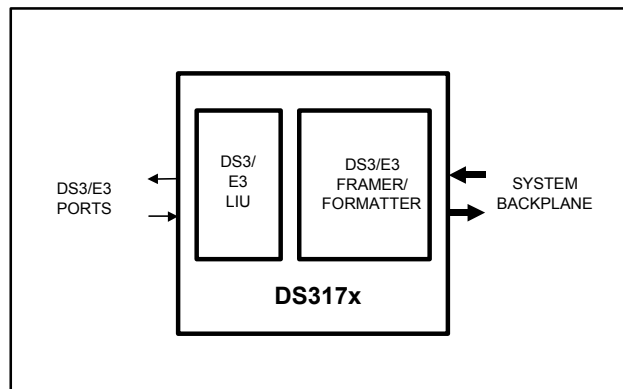

FEATURES

- Single (DS3171), Dual (DS3172), Triple (DS3173), or Quad (DS3174) Single-Chip Transceiver for DS3 and E3
- All Four Devices are Pin Compatible for Ease of Port Density Migration in the Same Printed Circuit Board Platform
- Each Port Independently Configurable
- Performs Receive Clock/Data Recovery and Transmit Waveshaping for DS3 and E3
- Jitter Attenuator can be Placed Either in the Receive or Transmit Paths
- Interfaces to 75Ω Coaxial Cable at Lengths Up to 380 meters, or 1246 feet (DS3) or 440 meters, or 1443 feet (E3)
- Uses 1:2 Transformers on Both Tx and Rx
- On-Chip DS3 (M23 or C-Bit) and E3 (G.751 or G.832) Framer(s)
- Ports Independently Configurable for DS3, E3
- Built-In HDLC Controllers with 256-Byte FIFOs for the Insertion/Extraction of DS3 PMDL, G.751 Sn Bit, and G.832 NR/GC Bytes
- On-Chip BERTs for PRBS and Repetitive Pattern Generation, Detection, and Analysis
- Large Performance-Monitoring Counters for Accumulation Intervals of at Least 1 Second
- Flexible Overhead Insertion/Extraction Ports for DS3, E3 Framers

Note: Some revisions of this device may incorporate deviations from published specifications known as errata. Multiple revisions of any device may be simultaneously available through various sales channels. For information about device errata, click here: www.maxim-ic.com/errata.

FEATURES (CONTINUED)

- Loopbacks Include Line, Diagnostic, Framer, Payload, and Analog with Capabilities to Insert AIS in the Directions Away from Loopback Directions
- Ports can be Disabled to Reduce Power
- Integrated Clock Rate Adapter to Generate the Remaining Internally Required 44.736MHz (DS3) and 34.368MHz (E3) from a Single Clock Reference Source at One of Three Standard Frequencies (DS3, E3, STS-1)
- Pin Compatible with the DS318x Family of Devices and the DS316x Family of Devices
- 8-/16-Bit Generic Microprocessor Interface
- Low-Power (~1.73W) 3.3V Operation (5V Tolerant I/O)
- Small High-Density Thermally Enhanced Plastic BGA Packaging (TE-PBGA) with 1.27mm Pitch
- Industrial Temperature Operation: -40°C to +85°C
- IEEE1149.1 JTAG Test Port

DETAILED DESCRIPTION

The DS3171 (single), DS3172 (dual), DS3173 (triple), and DS3174 (quad) perform framing, formatting, and line transmission and reception. These devices contain integrated LIU(s), framer/formatter for M23 DS3, C-bit DS3, G.751 E3, G.832 E3, or a combination of the above signal formats.

Each LIU has independent receive and transmit paths. The receiver LIU block performs clock and data recovery from a B3ZS- or HDB3-coded AMI signal and monitors for loss of the incoming signal, or can be bypassed for direct clock and data inputs. The receiver LIU block optionally performs B3ZS/HDB3 decoding. The transmitter LIU drives standard pulse-shape waveforms onto 75Ω coaxial cable or can be bypassed for direct clock and data outputs. The jitter attenuator can be placed in either transmit or receive data path when the LIU is enabled. The DS3/E3 framers transmit and receive serial data in properly formatted M23 DS3, C-bit DS3, G.751 E3, or G.832 E3 data streams. Unused functions can be powered down to reduce device power. The DS317x DS3/E3 SCTs conform to the telecommunications standards listed in Section [4](#).

1 BLOCK DIAGRAMS

Figure 1-1 shows the external components required at each LIU interface for proper operation. Figure 1-2 shows the functional block diagram of one channel DS3/E3 LIU.

Figure 1-1. LIU External Connections for a DS3/E3 Port of a DS317x Device

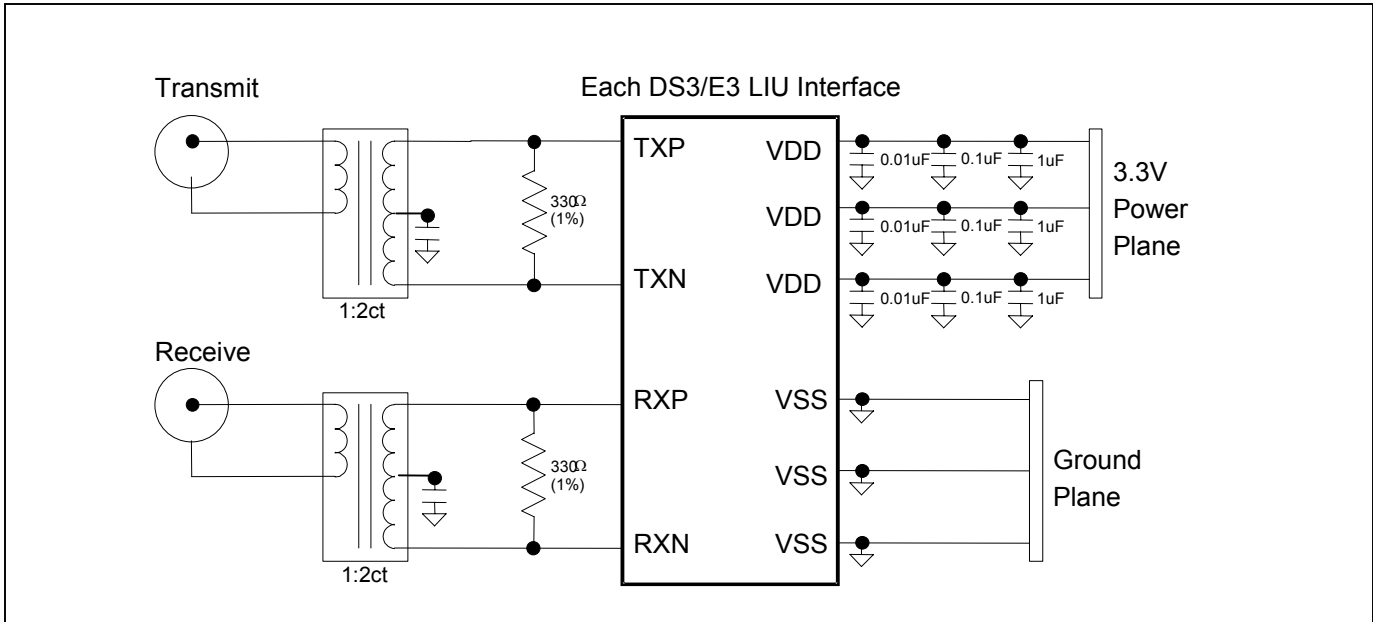

Figure 1-2. DS317x Functional Block Diagram

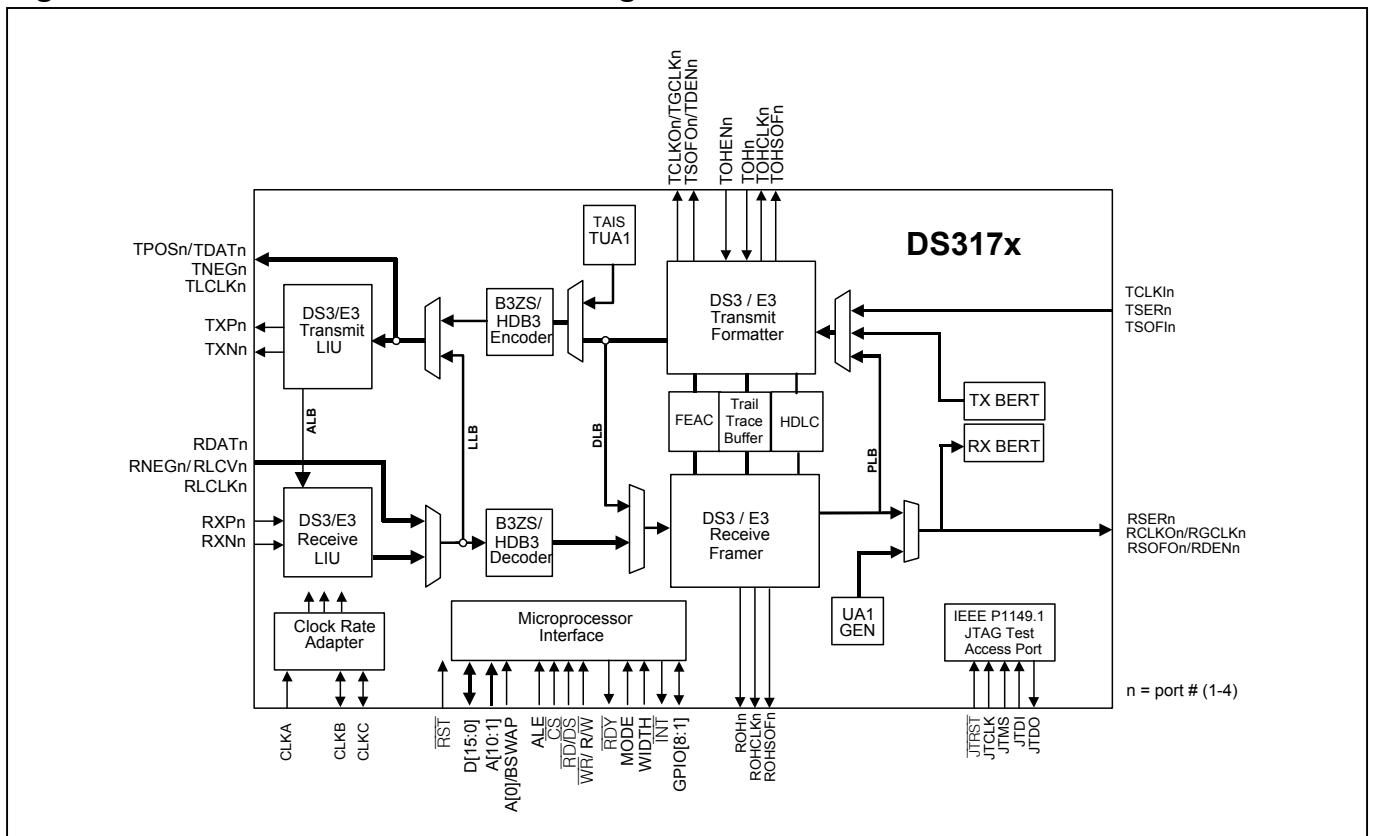

TABLE OF CONTENTS

1	BLOCK DIAGRAMS	3
2	APPLICATIONS	12
3	FEATURE DETAILS	13
3.1	GLOBAL FEATURES.....	13
3.2	RECEIVE DS3/E3 LIU FEATURES	13
3.3	RECEIVE DS3/E3 FRAMER FEATURES.....	13
3.4	TRANSMIT DS3/E3 FORMATTER FEATURES.....	13
3.5	TRANSMIT DS3/E3 LIU FEATURES	14
3.6	JITTER ATTENUATOR FEATURES.....	14
3.7	CLOCK RATE ADAPTER FEATURES	14
3.8	HDLC OVERHEAD CONTROLLER FEATURES.....	14
3.9	FEAC CONTROLLER FEATURES.....	14
3.10	TRAIL TRACE BUFFER FEATURES	15
3.11	BIT ERROR RATE TESTER (BERT) FEATURES	15
3.12	LOOPBACK FEATURES	15
3.13	MICROPROCESSOR INTERFACE FEATURES.....	15
3.14	TEST FEATURES	15
4	STANDARDS COMPLIANCE	16
5	ACRONYMS AND GLOSSARY	17
6	MAJOR OPERATIONAL MODES	18
6.1	DS3/E3 SCT MODE	18
6.2	DS3/E3 CLEAR CHANNEL MODE	20
7	MAJOR LINE INTERFACE OPERATING MODES	21
7.1	DS3HDB3/B3ZS/AMI LIU MODE	21
7.2	HDB3/B3ZS/AMI NON-LIU LINE INTERFACE MODE	23
7.3	UNI LINE INTERFACE MODE.....	24
8	PIN DESCRIPTIONS	25
8.1	SHORT PIN DESCRIPTIONS.....	25
8.2	DETAILED PIN DESCRIPTIONS.....	28
8.3	PIN FUNCTIONAL TIMING	36
8.3.1	<i>Line IO</i>	36
8.3.2	<i>DS3/E3 Framing Overhead Functional Timing</i>	39
8.3.3	<i>DS3/E3 Serial Data Interface</i>	40
8.3.4	<i>Microprocessor Interface Functional Timing</i>	42
8.3.5	<i>JTAG Functional Timing</i>	47
9	INITIALIZATION AND CONFIGURATION	48
9.1	MONITORING AND DEBUGGING	49
10	FUNCTIONAL DESCRIPTION	50
10.1	PROCESSOR BUS INTERFACE.....	50
10.1.1	<i>8/16 Bit Bus Widths</i>	50
10.1.2	<i>Ready Signal (RDY)</i>	50
10.1.3	<i>Byte Swap Modes</i>	50
10.1.4	<i>Read-Write / Data Strobe Modes</i>	50
10.1.5	<i>Clear on Read / Clear on Write Modes</i>	50
10.1.6	<i>Global Write Method</i>	51
10.1.7	<i>Interrupt and Pin Modes</i>	51
10.1.8	<i>Interrupt Structure</i>	51
10.2	CLOCKS	52
10.2.1	<i>Line Clock Modes</i>	52

10.2.2	Sources of Clock Output Pin Signals	54
10.2.3	Line IO Pin Timing Source Selection	57
10.2.4	Clock Structures On Signal IO Pins	59
10.2.5	Gapped Clocks	60
10.3	RESET AND POWER-DOWN	60
10.4	GLOBAL RESOURCES	63
10.4.1	Clock Rate Adapter (CLAD)	63
10.4.2	8 kHz Reference Generation	64
10.4.3	One Second Reference Generation	66
10.4.4	General-Purpose IO Pins	66
10.4.5	Performance Monitor Counter Update Details	67
10.4.6	Transmit Manual Error Insertion	68
10.5	PER PORT RESOURCES	69
10.5.1	Loopbacks	69
10.5.2	Loss Of Signal Propagation	71
10.5.3	AIS Logic	71
10.5.4	Loop Timing Mode	74
10.5.5	HDLC Overhead Controller	74
10.5.6	Trail Trace	74
10.5.7	BERT	74
10.5.8	SCT port pins	74
10.5.9	Framing Modes	76
10.5.10	Line Interface Modes	76
10.6	DS3/E3 FRAMER / FORMATTER	78
10.6.1	General Description	78
10.6.2	Features	78
10.6.3	Transmit Formatter	79
10.6.4	Receive Framer	79
10.6.5	C-Bit DS3 Framer/Formatter	83
10.6.6	M23 DS3 Framer/Formatter	86
10.6.7	G.751 E3 Framer/Formatter	88
10.6.8	G.832 E3 Framer/Formatter	90
10.7	HDLC OVERHEAD CONTROLLER	96
10.7.1	General Description	96
10.7.2	Features	96
10.7.3	Transmit FIFO	97
10.7.4	Transmit HDLC Overhead Processor	97
10.7.5	Receive HDLC Overhead Processor	98
10.7.6	Receive FIFO	98
10.8	TRAIL TRACE CONTROLLER	99
10.8.1	General Description	99
10.8.2	Features	99
10.8.3	Functional Description	100
10.8.4	Transmit Data Storage	100
10.8.5	Transmit Trace ID Processor	100
10.8.6	Transmit Trail Trace Processing	100
10.8.7	Receive Trace ID Processor	100
10.8.8	Receive Trail Trace Processing	101
10.8.9	Receive Data Storage	101
10.9	FEAC CONTROLLER	102
10.9.1	General Description	102
10.9.2	Features	102
10.9.3	Functional Description	102
10.10	LINE ENCODER/DECODER	104
10.10.1	General Description	104
10.10.2	Features	104
10.10.3	B3ZS/HDB3 Encoder	104

10.10.4	Transmit Line Interface	105
10.10.5	Receive Line Interface	105
10.10.6	B3ZS/HDB3 Decoder	105
10.11	BERT	107
10.11.1	General Description	107
10.11.2	Features	107
10.11.3	Configuration and Monitoring	107
10.11.4	Receive Pattern Detection	108
10.11.5	Transmit Pattern Generation	110
10.12	LIU—LINE INTERFACE UNIT	111
10.12.1	General Description	111
10.12.2	Features	111
10.12.3	Detailed Description	112
10.12.4	Transmitter	112
10.12.5	Receiver	113
11	OVERALL REGISTER MAP	116
12	REGISTER MAPS AND DESCRIPTIONS	119
12.1	REGISTERS BIT MAPS	119
12.1.1	Global Register Bit Map	119
12.1.2	HDLC Register Bit Map	122
12.1.3	T3 Register Bit Map	124
12.1.4	E3 G.751 Register Bit Map	124
12.1.5	E3 G.832 Register Bit Map	125
12.1.6	Clear Channel Register Bit Map	126
12.2	GLOBAL REGISTERS	127
12.2.1	Register Bit Descriptions	127
12.3	PER PORT COMMON	134
12.3.1	Register Bit Descriptions	134
12.4	BERT	144
12.4.1	BERT Register Map	144
12.4.2	BERT Register Bit Descriptions	144
12.5	B3ZS/HDB3 LINE ENCODER/DECODER	152
12.5.1	Transmit Side Line Encoder/Decoder Register Map	152
12.5.2	Receive Side Line Encoder/Decoder Register Map	153
12.6	HDLC	157
12.6.1	HDLC Transmit Side Register Map	157
12.6.2	HDLC Receive Side Register Map	161
12.7	FEAC CONTROLLER	165
12.7.1	FEAC Transmit Side Register Map	165
12.7.2	FEAC Receive Side Register Map	167
12.8	TRAIL TRACE	170
12.8.1	Trail Trace Transmit Side	170
12.8.2	Trail Trace Receive Side Register Map	172
12.9	DS3/E3 FRAMER	176
12.9.1	Transmit DS3	176
12.9.2	Receive DS3 Register Map	178
12.9.3	Transmit G.751 E3	187
12.9.4	Receive G.751 E3 Register Map	189
12.9.5	Transmit G.832 E3 Register Map	195
12.9.6	Receive G.832 E3 Register Map	198
12.9.7	Transmit Clear Channel	207
12.9.8	Receive Clear Channel	208
13	JTAG INFORMATION	210
13.1	JTAG DESCRIPTION	210
13.2	JTAG TAP CONTROLLER STATE MACHINE DESCRIPTION	211
13.3	JTAG INSTRUCTION REGISTER AND INSTRUCTIONS	213

13.4	JTAG ID CODES.....	214
13.5	JTAG FUNCTIONAL TIMING.....	214
13.6	IO PINS	214
14	PIN ASSIGNMENTS	215
15	PACKAGE INFORMATION	218
15.1	400-LEAD TE-PBGA (27MM X 27MM, 1.27MM PITCH) (56-G6003-003)	218
16	PACKAGE THERMAL INFORMATION	219
17	DC ELECTRICAL CHARACTERISTICS	220
18	AC TIMING CHARACTERISTICS	222
18.1	FRAMER AC CHARACTERISTICS	224
18.2	LINE INTERFACE AC CHARACTERISTICS	224
18.3	MISC PIN AC CHARACTERISTICS.....	225
18.4	OVERHEAD PORT AC CHARACTERISTICS.....	225
18.5	MICRO INTERFACE AC CHARACTERISTICS	226
18.6	CLAD JITTER CHARACTERISTICS	229
18.7	LIU INTERFACE AC CHARACTERISTICS	229
18.7.1	<i>Waveform Templates</i>	229
18.7.2	<i>LIU Input/Output Characteristics</i>	231
18.8	JTAG INTERFACE AC CHARACTERISTICS.....	233
19	REVISION HISTORY	234

LIST OF FIGURES

Figure 1-1. LIU External Connections for a DS3/E3 Port of a DS317x Device	3
Figure 1-2. DS317x Functional Block Diagram	3
Figure 2-1. Four-Port DS3/E3 Line Card	12
Figure 6-1. DS3/E3 SCT Mode	19
Figure 6-2. DS3/E3 Clear Channel Mode	20
Figure 7-1. HDB3/B3ZS/AMI LIU Mode	22
Figure 7-2. HDB3/B3ZS/AMI Non-LIU Line Interface Mode	23
Figure 7-3. UNI Line Interface Mode	24
Figure 8-1. TX Line IO B3ZS Functional Timing Diagram	36
Figure 8-2. TX Line IO HDB3 Functional Timing Diagram	37
Figure 8-3. RX Line IO B3ZS Functional Timing Diagram	37
Figure 8-4. RX Line IO HDB3 Functional Timing Diagram	38
Figure 8-5. TX Line IO UNI Functional Timing Diagram	38
Figure 8-6. RX Line IO UNI Functional Timing Diagram	39
Figure 8-7. DS3 Framing Receive Overhead Port Timing	39
Figure 8-8. E3 G.751 Framing Receive Overhead Port Timing	39
Figure 8-9. E3 G.832 Framing Receive Overhead Port Timing	39
Figure 8-10. DS3 Framing Transmit Overhead Port Timing	40
Figure 8-11. E3 G.751 Framing Transmit Overhead Port Timing	40
Figure 8-12. E3 G.832 Framing Transmit Overhead Port Timing	40
Figure 8-13. DS3 SCT Mode Transmit Serial Interface Pin Timing	41
Figure 8-14. E3 G.751 SCT Mode Transmit Serial Interface Pin Timing	41
Figure 8-15. E3 G.832 SCT Mode Transmit Serial Interface Pin Timing	41
Figure 8-16. DS3 SCT Mode Receive Serial Interface Pin Timing	42
Figure 8-17. E3 G.751 SCT Mode Receive Serial Interface Pin Timing	42
Figure 8-18. E3 G.832 SCT Mode Receive Serial Interface Pin Timing	42
Figure 8-19. 16-Bit Mode Write	43
Figure 8-20. 16-Bit Mode Read	43
Figure 8-21. 8-Bit Mode Write	44
Figure 8-22. 8-Bit Mode Read	44
Figure 8-23. 16-Bit Mode without Byte Swap	45
Figure 8-24. 16-Bit Mode with Byte Swap	45
Figure 8-25. Clear Status Latched Register on Read	46
Figure 8-26. Clear Status Latched Register on Write	46
Figure 8-27. RDY Signal Functional Timing Write	47
Figure 8-28. RDY Signal Functional Timing Read	47
Figure 10-1. Interrupt Structure	52
Figure 10-2. Internal TX Clock	55
Figure 10-3. Internal RX Clock	56
Figure 10-4. Example IO Pin Clock Muxing	60
Figure 10-5. Reset Sources	61
Figure 10-6. CLAD Block	63
Figure 10-7. 8KREF Logic	65
Figure 10-8. Performance Monitor Update Logic	68
Figure 10-9. Transmit Error Insert Logic	69
Figure 10-10. Loopback Modes	70
Figure 10-11. ALB Mux	70
Figure 10-12. AIS Signal Flow	73
Figure 10-13. Framer Detailed Block Diagram	78
Figure 10-14. DS3 Frame Format	80
Figure 10-15. DS3 Subframe Framer State Diagram	80
Figure 10-16. DS3 Multiframe Framer State Diagram	81
Figure 10-17. G.751 E3 Frame Format	88
Figure 10-18. G.832 E3 Frame Format	91
Figure 10-19. MA Byte Format	91

Figure 10-20. HDLC Controller Block Diagram	96
Figure 10-21. Trail Trace Controller Block Diagram	99
Figure 10-22. Trail Trace Byte (DT = Trail Trace Data)	101
Figure 10-23. FEAC Controller Block Diagram	102
Figure 10-24. FEAC Codeword Format	103
Figure 10-25. Line Encoder/Decoder Block Diagram	104
Figure 10-26. B3ZS Signatures	106
Figure 10-27. HDB3 Signatures	106
Figure 10-28. BERT Block Diagram	107
Figure 10-29. PRBS Synchronization State Diagram	109
Figure 10-30. Repetitive Pattern Synchronization State Diagram	110
Figure 10-31. LIU Functional Diagram	111
Figure 10-32. DS3/E3 LIU Block Diagram	112
Figure 10-33. Receiver Jitter Tolerance	115
Figure 13-1. JTAG Block Diagram	210
Figure 13-2. JTAG TAP Controller State Machine	211
Figure 13-3. JTAG Functional Timing	214
Figure 14-1. DS3174 Pin Assignments—400-Lead PBGA	215
Figure 14-2. DS3173 Pin Assignments—400-Lead PBGA	216
Figure 14-3. DS3172 Pin Assignments—400-Lead PBGA	216
Figure 14-4. DS3171 Pin Assignments—400-Lead PBGA	217
Figure 18-1. Clock Period and Duty Cycle Definitions	222
Figure 18-2. Rise Time, Fall Time, and Jitter Definitions	222
Figure 18-3. Hold, Setup, and Delay Definitions (Rising Clock Edge)	222
Figure 18-4. Hold, Setup, and Delay Definitions (Falling Clock Edge)	223
Figure 18-5. To/From Hi Z Delay Definitions (Rising Clock Edge)	223
Figure 18-6. To/From Hi Z Delay Definitions (Falling Clock Edge)	223
Figure 18-7. Micro Interface Nonmultiplexed Read/Write Cycle	227
Figure 18-8. Micro Interface Multiplexed Read Cycle	228
Figure 18-9. E3 Waveform Template	230
Figure 18-10. DS3 Pulse Mask Template	231

LIST OF TABLES

Table 4-1. Standards Compliance	16
Table 7-1. HDB3/B3ZS/AMI LIU Mode Configuration Registers	21
Table 7-2. HDB3/B3ZS/AMI Non-LIU Mode Configuration Registers	23
Table 7-3. UNI Line Interface Mode Configuration Registers	24
Table 8-1. DS3174 Short Pin Descriptions	25
Table 8-2. Detailed Pin Descriptions	28
Table 9-1. Configuration of Port Register Settings	49
Table 10-1. LIU Enable Table	54
Table 10-2. All Possible Clock Sources Based on Mode and Loopback	54
Table 10-3. Source Selection of TLCLK Clock Signal	55
Table 10-4. Source Selection of TCLKOn (internal TX clock)	56
Table 10-5. Source Selection of RCLKO Clock Signal (internal RX clock)	56
Table 10-6. Transmit Line Interface Signal Pin Valid Timing Source Select	57
Table 10-7. Transmit Framer Pin Signal Timing Source Select	58
Table 10-8. Receive Line Interface Pin Signal Timing Source Select	58
Table 10-9. Receive Framer Pin Signal Timing Source Select	59
Table 10-10. Reset and Power-Down Sources	62
Table 10-11. CLAD IO Pin Decode	64
Table 10-12. Global 8 kHz Reference Source Table	65
Table 10-13. Port 8 kHz Reference Source Table	65
Table 10-14. GPIO Global Signals	66
Table 10-15. GPIO Pin Global Mode Select Bits	66
Table 10-16. GPIO Port Alarm Monitor Select	67
Table 10-17. Loopback Mode Selections	69
Table 10-18. Line AIS Enable Modes	73
Table 10-19. Payload (Downstream) AIS Enable Modes	74
Table 10-20. TSOFIn Input Pin Functions	75
Table 10-21. TSOFOn/TDENn/Output Pin Functions	75
Table 10-22. TCLKOn/TGCLKn Output Pin Functions	75
Table 10-23. RSOFOn/RDENn Output Pin Functions	75
Table 10-24. RCLKOn/RGCLKn Output Pin Functions	76
Table 10-25. Framing Mode Select Bits FM[2:0]	76
Table 10-26. Line Mode Select Bits LM[2:0]	77
Table 10-27. C-Bit DS3 Frame Overhead Bit Definitions	83
Table 10-28. M23 DS3 Frame Overhead Bit Definitions	86
Table 10-29. G.832 E3 Frame Overhead Bit Definitions	91
Table 10-30. Payload Label Match Status	95
Table 10-31. Pseudorandom Pattern Generation	108
Table 10-32. Repetitive Pattern Generation	108
Table 10-33. Transformer Characteristics	113
Table 10-34. Recommended Transformers	114
Table 11-1. Global and Test Register Address Map	117
Table 11-2. Per Port Register Address Map	118
Table 12-1. Global Register Bit Map	119
Table 12-2. Port Register Bit Map	120
Table 12-3. BERT Register Bit Map	120
Table 12-4. Line Register Bit Map	121
Table 12-5. HDLC Register Bit Map	122
Table 12-6. FEAC Register Bit Map	122
Table 12-7. Trail Trace Register Bit Map	123
Table 12-8. T3 Register Bit Map	124
Table 12-9. E3 G.751 Register Bit Map	124
Table 12-10. E3 G.832 Register Bit Map	125
Table 12-11. Clear Channel Register Bit Map	126
Table 12-12. Global Register Map	127

Table 12-13. Per Port Common Register Map	134
Table 12-14. BERT Register Map.....	144
Table 12-15. Transmit Side B3ZS/HDB3 Line Encoder/Decoder Register Map	152
Table 12-16. Receive Side B3ZS/HDB3 Line Encoder/Decoder Register Map	153
Table 12-17. Transmit Side HDLC Register Map	157
Table 12-18. Receive Side HDLC Register Map	161
Table 12-19. FEAC Transmit Side Register Map	165
Table 12-20. FEAC Receive Side Register Map	167
Table 12-21. Transmit Side Trail Trace Register Map.....	170
Table 12-22. Trail Trace Receive Side Register Map.....	172
Table 12-23. Transmit DS3 Framer Register Map	176
Table 12-24. Receive DS3 Framer Register Map	178
Table 12-25. Transmit G.751 E3 Framer Register Map	187
Table 12-26. Receive G.751 E3 Framer Register Map	189
Table 12-27. Transmit G.832 E3 Framer Register Map	195
Table 12-28. Receive G.832 E3 Framer Register Map	198
Table 12-29. Transmit Clear Channel Register Map.....	207
Table 12-30. Receive Clear Channel Register Map	208
Table 13-1. JTAG Instruction Codes	213
Table 13-2. JTAG ID Codes	214
Table 14-1. Pin Assignment Breakdown	215
Table 17-1. Recommended DC Operating Conditions	220
Table 17-2. DC Electrical Characteristics	220
Table 17-3. Output Pin Drive	221
Table 18-1. Framer Port Timing.....	224
Table 18-2. Line Interface Timing	224
Table 18-3. Misc Pin Timing	225
Table 18-4. Overhead Port Timing	225
Table 18-5. Micro Interface Timing.....	226
Table 18-6. DS3 Waveform Template	229
Table 18-7. DS3 Waveform Test Parameters and Limits	229
Table 18-8. E3 Waveform Test Parameters and Limits.....	230
Table 18-9. Receiver Input Characteristics—DS3 Mode.....	231
Table 18-10. Receiver Input Characteristics—E3 Mode	232
Table 18-11. Transmitter Output Characteristics—DS3 Modes	232
Table 18-12. Transmitter Output Characteristics—E3 Mode	232
Table 18-13. JTAG Interface Timing.....	233

2 APPLICATIONS

- Access Concentrators
- Multiservice Access Platforms
- ATM and Frame Relay Equipment
- Routers and Switches
- SONET/SDH ADM
- SONET/SDH Muxes
- PBXs
- Digital Cross Connect
- PDH Multiplexer/Demultiplexer
- Test Equipment
- Integrated Access Device (IAD)

[Figure 2-1](#) shows an application for the DS3174.

Figure 2-1. Four-Port DS3/E3 Line Card

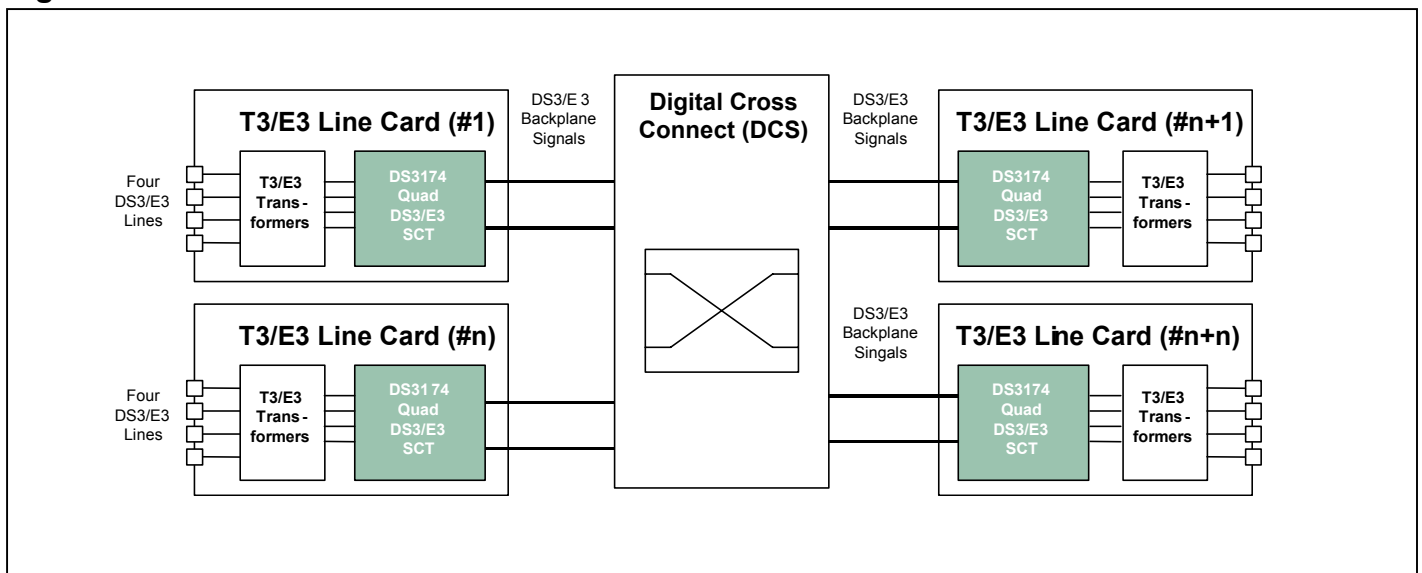

3 FEATURE DETAILS

The following sections describe the features provided by the DS3171 (single), DS3172 (dual), DS3173 (triple), and DS3174 (quad) single-chip transceivers (framers and LIUs, SCTs).

3.1 Global Features

- Supports the following transmission protocols:
 - C-bit DS3
 - M23 DS3
 - G.751 E3
 - G.832 E3
 - Clear-channel serial data at line rates up to 52 Mb/s
- Optional transmit loop timed clock(s) mode using the associated port's receive clock(s)
- Optional transmit clock mode using references generated by the internal Clock Rate Adapter (CLAD)
- Requires only a single reference clock for all three LIU data rates using internal CLAD
- The LIU can be powered down and bypassed for direct logic IO to/from line circuits.
- Jitter attenuator can be placed in either transmit or receive path when the LIU is enabled.
- Clock, data and control signals can be inverted for a direct interface to many other devices
- Detection of loss of transmit clock and loss of receive clock
- Automatic one-second, external or manual update of performance monitoring counters
- Each port can be placed into a low-power standby mode when not being used
- Framing and line code error insertion available

3.2 Receive DS3/E3 LIU Features

- AGC/Equalizer block handles from 0 dB to 15 dB of cable loss
- Loss-of-lock PLL status indication
- Interfaces directly to a DSX monitor signal (20 dB flat loss) using built-in pre-amp
- Digital and analog Loss of Signal (LOS) detectors (ANSI T1.231 and ITU G.775)
- Per-channel power-down control

3.3 Receive DS3/E3 Framer Features

- Frame synchronization for M23 or C-bit Parity DS3, or G.751 E3 or G.832 E3
- B3ZS/HDB3/AMI decoding
- Detection and accumulation of bipolar violations (BPV), code violations (CV), excessive zeros occurrences (EXZ), F-bit errors, M-bit errors, FAS errors, LOF occurrences, P-bit parity errors, CP-bit parity errors, BIP-8 errors, and far end block errors (FEBE)
- Detection of RDI, AIS, DS3 idle signal, loss of signal (LOS), severely errored framing event (SEFE), change of frame alignment (COFA), receipt of B3ZS/HDB3 codewords, DS3 application ID bit, DS3 M23/C-bit format mismatch, G.751 national bit, and G.832 RDI (FERF), payload type, and timing marker bits
- HDLC port for DS3 path maintenance data link (PMDL), G.751 national bit or G.832 NR or GC channels
- FEAC port for DS3 FEAC channel
- 16-byte Trail Trace Buffer port for G.832 trail access point identifier
- DS3 M23 C bits and stuff bits configurable as payload or overhead, stored in registers for software inspection
- Most framing overhead fields presented on the receive overhead port

3.4 Transmit DS3/E3 Formatter Features

- Insertion of framing overhead for M23 or C-bit parity DS3, or G.751 E3 or G.832 E3
- B3ZS/HDB3 encoding
- Generation of RDI, AIS, and DS3 idle signal
- Automatic or manual insertion of bipolar violations (BPVs), excessive zeros (EXZ) occurrences, F-bit errors, M-bit errors, FAS errors, P-bit parity errors, CP-bit parity errors, BIP-8 errors, and far end block errors (FEBE)
- HDLC port for DS3 path maintenance data link (PMDL), G.751 national bit or G.832 NR or GC channels

- FEAC port for DS3 FEAC channel can be configured to send one codeword, one codeword continuously, or two different codewords back-to-back to send DS3 Line Loopback commands
- 16-byte Trail Trace Buffer port for the G.832 trail access point identifier
- Insertion of G.832 payload type, and timing marker bits from registers
- DS3 M23 C bits configurable as payload or overhead, as overhead they can be controlled from registers or the transmit overhead port
- Most framing overhead fields can be sourced from transmit overhead port
- Formatter bypass mode for clear channel or externally defined format applications

3.5 Transmit DS3/E3 LIU Features

- Wide 50±20% transmit clock duty cycle
- Line Build-Out (LBO) control
- Tri-state line driver outputs support protection switching applications
- Per-channel power-down control
- Output driver monitor status indication

3.6 Jitter Attenuator Features

- Fully integrated and requiring no external components
- Can be placed in transmit or receive path
- FIFO depth of 16 bits
- Standard compliant transmission jitter and wander

3.7 Clock Rate Adapter Features

- Generation of the internally needed DS3 (44.736 MHz) and E3 (34.368 MHz) clocks from a single input reference clock
- Input reference clock can be 51.84 MHz, 44.736MHz or 34.368 MHz
- Internally derived clocks can be used as references for LIU and jitter attenuator
- Derived clocks can be transmitted off-chip for external system use
- Standards compliant jitter and wander requirements.

3.8 HDLC Overhead Controller Features

- Each port has a dedicated HDLC controller for DS3/E3 framer link management
- 256-byte receive and transmit FIFOs
- Handles all of the normal Layer 2 tasks including zero stuffing/de-stuffing, FCS generation/checking, abort generation/checking, flag generation/detection, and byte alignment
- Programmable high and low water marks for the transmit and receive FIFOs
- Terminates the Path Maintenance Data Link in DS3 C-bit Parity mode and optionally the G.751 Sn bit or the G.832 NR or GC channels
- RX data is forced to all ones during LOS, LOF and AIS detection to eliminate false packets

3.9 FEAC Controller Features

- Each port has a dedicated FEAC controller for DS3/E3 link management
- Designed to handle multiple FEAC codewords without Host intervention
- Receive FEAC automatically validates incoming codewords and stores them in a 4-byte FIFO
- Transmit FEAC can be configured to send one codeword, one codeword continuously, or two different codewords back-to-back to send DS3 Line Loopback commands
- Terminates the FEAC channel in DS3 C-Bit Parity mode and optionally the Sn bit in E3 mode

3.10 Trail Trace Buffer Features

- Each port has a dedicated Trail Trace Buffer for E3-G.832 link management
- Extraction and storage of the incoming G.832 trail access point identifier in a 16-byte receive register
- Insertion of the outgoing trail access point identifier from a 16-byte transmit register
- Receive trace identifier unstable status indication

3.11 Bit Error Rate Tester (BERT) Features

- Each port has a dedicated BERT tester
- Generation and detection of pseudo-random patterns and repetitive patterns from 1 to 32 bits in length
- Pattern insertion/extraction in DS3/E3 payload or entire data stream to and from the line interface
- Large 24-bit error counter allows testing to proceed for long periods without host intervention
- Errors can be inserted in the generated BERT patterns for diagnostic purposes (single bit errors or specific bit-error rates)

3.12 Loopback Features

- Analog interface loopback – ALB (transmit to receive)
- Line facility loopback – LLB (receive to transmit) with optional transmission of unframed all-one AIS payload toward system/trunk interface
- Framer diagnostic loopback – DLB (transmit to receive) with automatic transmission of DS3 AIS or unframed all-one AIS signal toward line/tributary interface(s)
- DS3/E3 framer payload loopback – PLB (receive to transmit) with optional transmission of unframed all-one AIS payload toward system/trunk interface
- Simultaneous line facility loopback and framer diagnostic loopback

3.13 Microprocessor Interface Features

- Multiplexed or non-multiplexed address bus modes
- 8-bit or 16-bit data bus modes
- Byte swapping option in 16-bit data bus mode
- Read/Write and Data Strobe modes
- Ready handshake output signal
- Global reset input pin
- Global interrupt output pin
- Two programmable I/O pins per port

3.14 Test Features

- Five pin JTAG port
- All functional pins are inout pins in JTAG mode
- Standard JTAG instructions: SAMPLE/PRELOAD, BYPASS, EXTEST, CLAMP, HIGHZ, IDCODE
- RAM BIST on all internal RAM
- Hi-Z pin to force all digital output and inout pins into HIZ
- TEST pin for manufacturing scan test modes

4 STANDARDS COMPLIANCE

Table 4-1. Standards Compliance

SPECIFICATION	SPECIFICATION TITLE
ANSI	
T1.102-1993	<i>Digital Hierarchy – Electrical Interfaces</i>
T1.107-1995	<i>Digital Hierarchy – Formats Specification</i>
T1.231-1997	<i>Digital Hierarchy – Layer 1 In-Service Digital Transmission Performance Monitoring</i>
T1.404-1994	<i>Network-to-Customer Installation – DS3 Metallic Interface Specification</i>
ETSI	
ETS 300 686	<i>Business TeleCommunications; 34Mbps and 140Mbps/s digital leased lines (D34U, D34S, D140U and D140S); Network interface presentation, 1996</i>
TBR 24	<i>Business TeleCommunications; 34Mbit/s digital unstructured and structured lease lines; attachment requirements for terminal equipment interface, 1997</i>
ETS EN 300 689	<i>Access and Terminals (AT); 34Mbps Digital Leased Lines (D34U and D34S); Terminal equipment interface, July 2001</i>
ETS 300 689	<i>Business TeleCommunications (BTC); 34 Mbps digital leased lines (D34U and D34S), Terminal equipment interface, V 1.2.1, 2001-07</i>
IETF	
RFC 2496	<i>Definition of Managed Objects for the DS3/E3 Interface Type, January, 1999</i>
ISO	
ISO 3309:1993	<i>Information Technology – Telecommunications & information exchange between systems – High Level Data Link Control (HDLC) procedures – Frame structure, Fifth Edition, 1993</i>
ITU-T	
G.703	<i>Physical/Electrical Characteristics of Hierarchical Digital Interfaces, 1991</i>
G.704	<i>Synchronous Frame Structures Used at 1544, 6312, 2048, 8488 and 44 736 kbit/s Hierarchical Levels, July, 1995</i>
G.751	<i>Digital Multiplex Equipment Operating at the Third Order Bit Rate of 34,368 kbit/s and the Fourth Order bit Rate of 139,264 kbit/s and Using Positive Justification, 1993</i>
G.775	<i>Loss Of Signal (LOS) and Alarm Indication Signal (AIS) Defect Detection and Clearance Criteria, November, 1994</i>
G.823	<i>The Control of Jitter and Wander Within Digital Networks Which are Based on the 2048 kbit/s Hierarchy, 1993</i>
G.824	<i>The Control of Jitter and Wander within Digital Networks that are Based on the 1544kbps Hierarchy, 1993</i>
G.832	<i>Transport of SDH Elements on PDH Networks – Frame and Multiplexing Structures, November, 1995</i>
I.432	<i>B-ISDN User-Network Interface – Physical Layer Specification, March, 1993</i>
O.151	<i>Error Performance Measuring Equipment Operating at the Primary Rate and Above, October, 1992</i>
Q.921	<i>ISDN User-Network Interface – Data Link Layer Specification, March 1993</i>
Telcordia	
GR-499-CORE	<i>Transport Systems Generic Requirements (TSGR): Common Requirements, Issue 2, December 1998</i>
GR-820-CORE	<i>Generic Digital Transmission Surveillance, Issue 1, November 1994</i>
IEEE	
IEEE Std 1149-1990	<i>IEEE Standard Test Access Port and Boundary-Scan Architecture, (Includes IEEE Std 1149-1993) October 21, 1993</i>

5 ACRONYMS AND GLOSSARY

Definition of the terms used in this Datasheet:

- CCM – Clear Channel Mode
- CLAD – Clock Rate Adapter
- Clear Channel – A Datastream with no framing included, also known as Unframed
- FRM – Frame Mode
- FSCT – Framer Single Chip Transceiver Mode
- HDLC – High Level Data Link Control
- Packet – HDLC packet
- SCT – Single Chip Transceiver (Framer and LIU)
- SCT Mode – DS3/E3 Framer and LIU,
- Unchannelized – See Clear Channel

6 MAJOR OPERATIONAL MODES

The major operational modes are determined by the FM[2:0] framer mode bits and a few other control bits. Unused features are powered down and the data paths are held in reset. The configuration registers of the unused features can be written to and read from. The function of some IO pins change in different operational modes. The line interface operational mode is determined by the LM[2:0] bits.

6.1 DS3/E3 SCT Mode

This mode is for standard operation that uses the device in the single chip transceiver mode. It utilizes the framer/formatter as well as the transmit/receive LIU.

FRAME MODE	FM[2:0]
DS3 C-bit Framed	000
DS3 M23 Framed	001
E3 G.751 Framed	010
E3 G.832 Framed	011

LIU MODE	LM[2:0]	TZSD & RZSD	TLEN PORT.CR2
JA Off, B3ZS or HDB3	001	0	0
JA RX, B3ZS or HDB3	010	0	0
JA TX, B3ZS or HDB3	011	0	0
JA Off, AMI	001	1	0
JA RX, AMI	010	1	0
JA TX, AMI	011	1	0

Figure 6-1. DS3/E3 SCT Mode

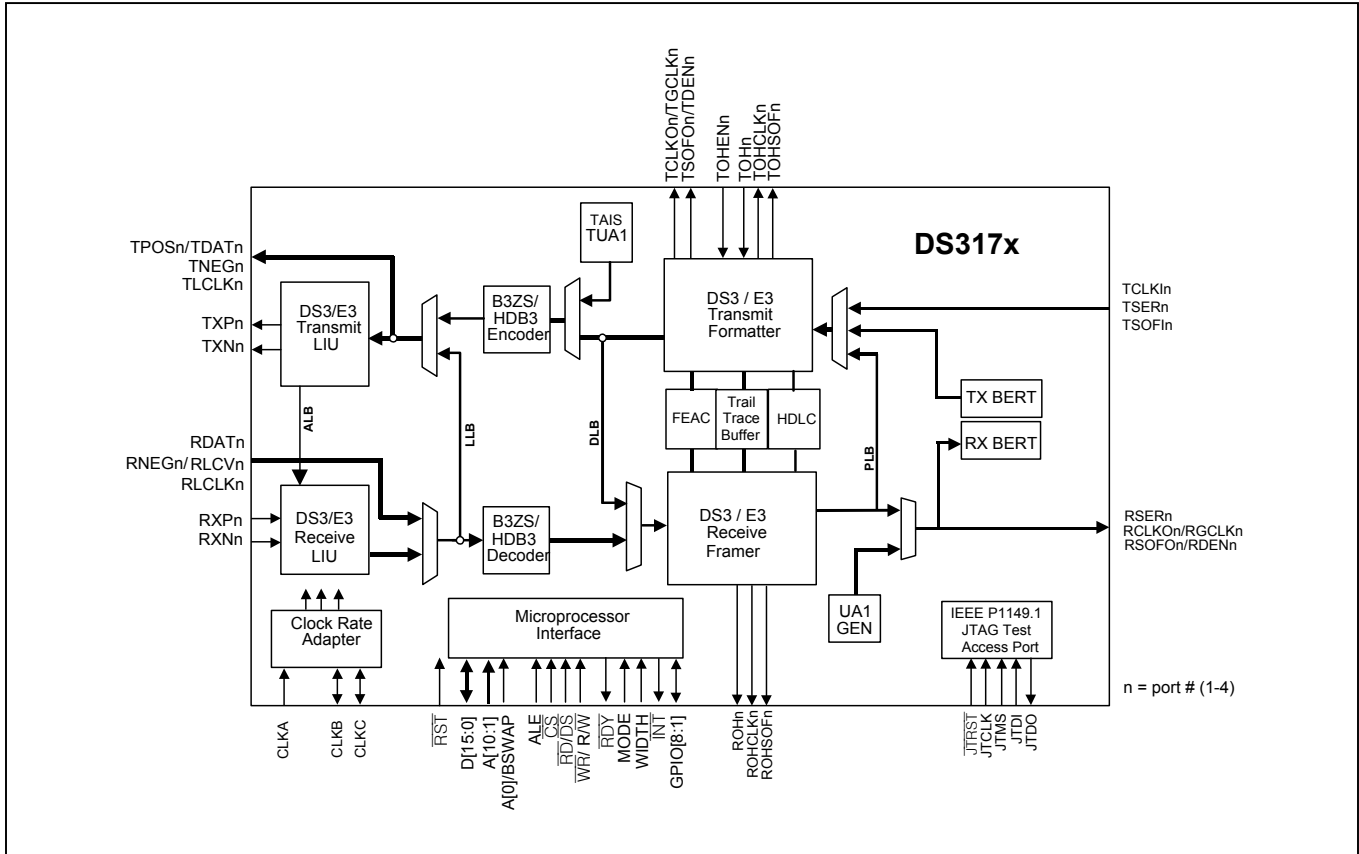

6.2 DS3/E3 Clear Channel Mode

This mode bypasses the framer/formatter for unchanneled datastreams that don't include DS3 framing or E3 framing.

MODE	FM[2:0]
Clear Channel	1XX

Figure 6-2. DS3/E3 Clear Channel Mode

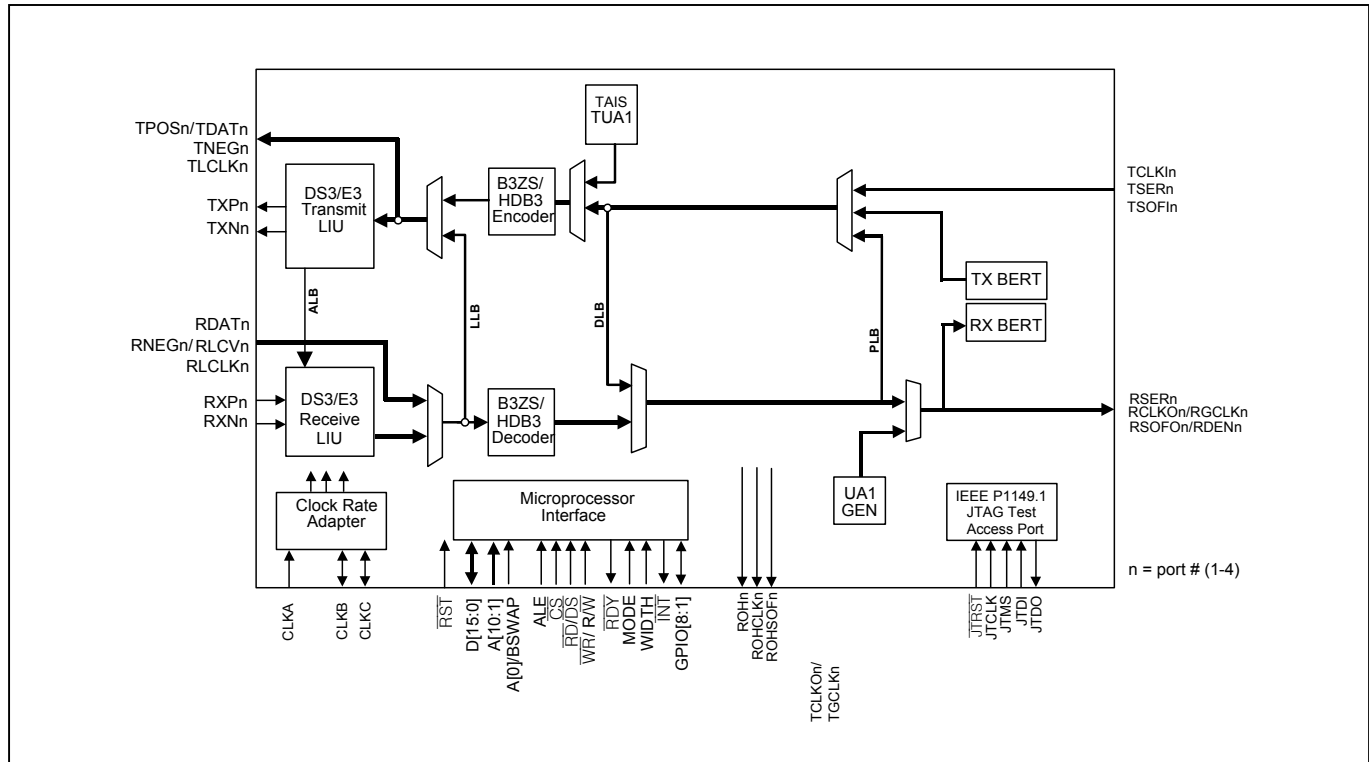

7 MAJOR LINE INTERFACE OPERATING MODES

The line interface modes provide the following functions:

1. Enabling/disabling of RX and TX LIU.
2. Enabling/Disabling of jitter attenuator (JA).
3. Selection of the location of JA, i.e. RX or TX path.
4. Selection of the line coding type: i.e. B3ZS/HDB3/AMI or UNI.

7.1 DS3HDB3/B3ZS/AMI LIU Mode

The TZCDS and RZCDS bits in the line encoder/decoder block select between no encoding/decoding (AMI) and encoding/decoding (B3ZS, HDB3). When the HDB3/B3ZS line decoder/encoder is enabled, the framing modes (FM bits) select between B3ZS and HDB3 line coding. The DS3 modes select the B3ZS line code while the E3 modes select the HDB3 line code.

Table 7-1. HDB3/B3ZS/AMI LIU Mode Configuration Registers

MODE	LM[2:0]	LINE.TCR.TZSD & LINE.RCR.RZSD	TLEN PORT.CR2
JA Off, B3ZS or HDB3	001	0	0
JA RX, B3ZS or HDB3	010	0	0
JA TX, B3ZS or HDB3	011	0	0
JA Off, AMI	001	1	0
JA RX, AMI	010	1	0
JA TX, AMI	011	1	0

Figure 7-1. HDB3/B3ZS/AMI LIU Mode

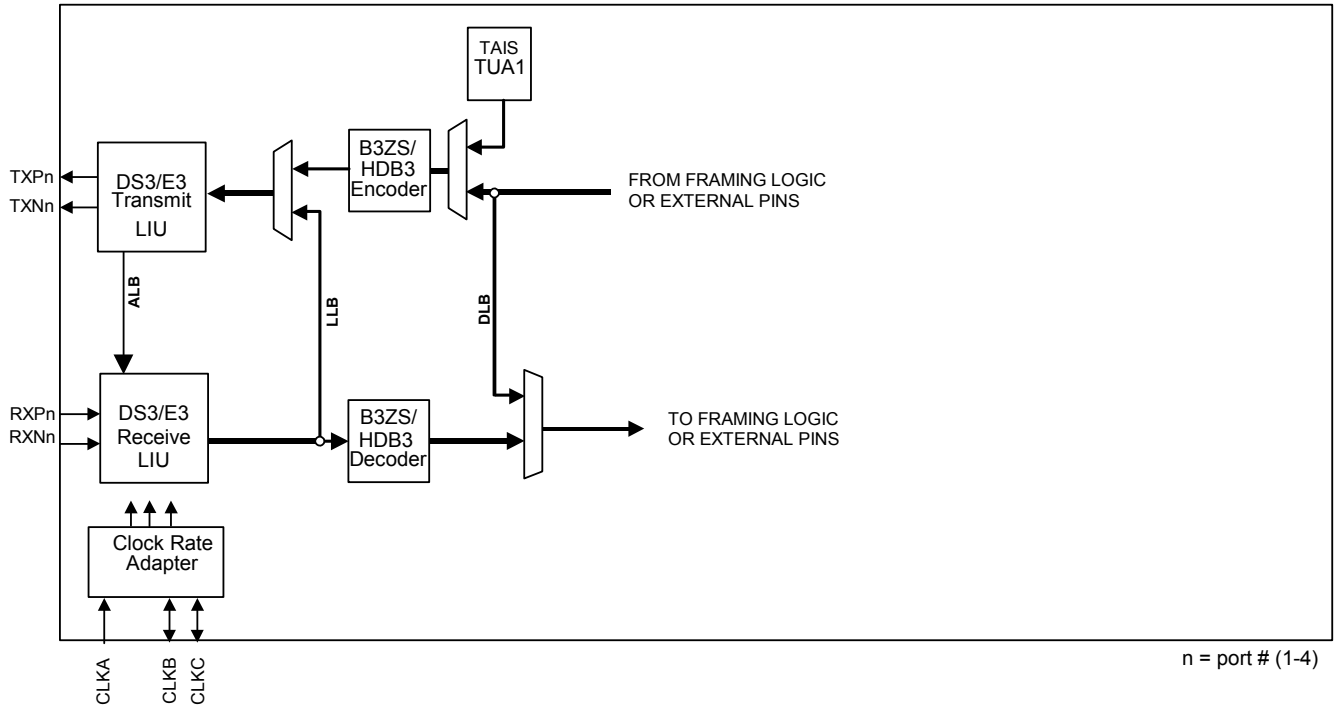

7.2 HDB3/B3ZS/AMI Non-LIU Line Interface Mode

The Non-LIU Line Interface Mode disables the LIU and a digital representation of AMI is output/input on the TPOS_n/TNEG_n signals and the RPOS_n/RNEG_n signals. Selection between AMI and HDB3/B3ZS is made via the LINE.TCR Register. HDB3 and B3ZS selection is controlled by the configuration selected by the FM bits. The DS3 modes select the B3ZS line code while the E3 modes select the HDB3 line code.

Table 7-2. HDB3/B3ZS/AMI Non-LIU Mode Configuration Registers

MODE	LM[2:0]	LINE.TCR.TZSD & LINE.RCR.RZSD	TLEN PORT.CR2
LIU Off, B3ZS or HDB3	000	0	1
LIU Off, AMI	000	1	1

Figure 7-2. HDB3/B3ZS/AMI Non-LIU Line Interface Mode

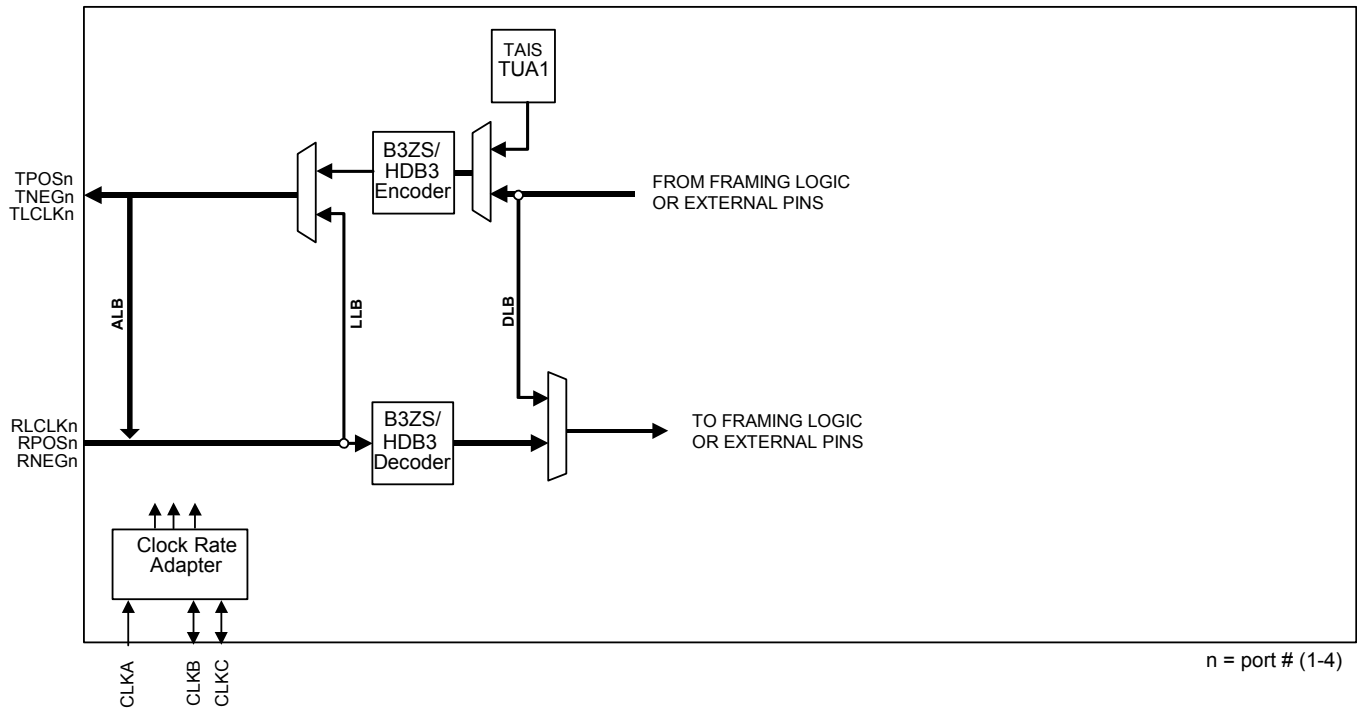

7.3 UNI Line Interface Mode

This mode is valid for all framing modes, providing a digital NRZ input/output on RDATn and TDATn and clocked by RLCLKn and TLCLKn. The B3ZS/HDB3 decoder/encoder block is disabled except for the BPV counter, which is used to count RLCV errors.

Table 7-3. UNI Line Interface Mode Configuration Registers

MODE	LM[2:0]	LINE.TCR.TZSD & LINE.RCR.RZSD	TLEN PORT.CR2
Unipolar Mode	1XX	X	1

Figure 7-3. UNI Line Interface Mode

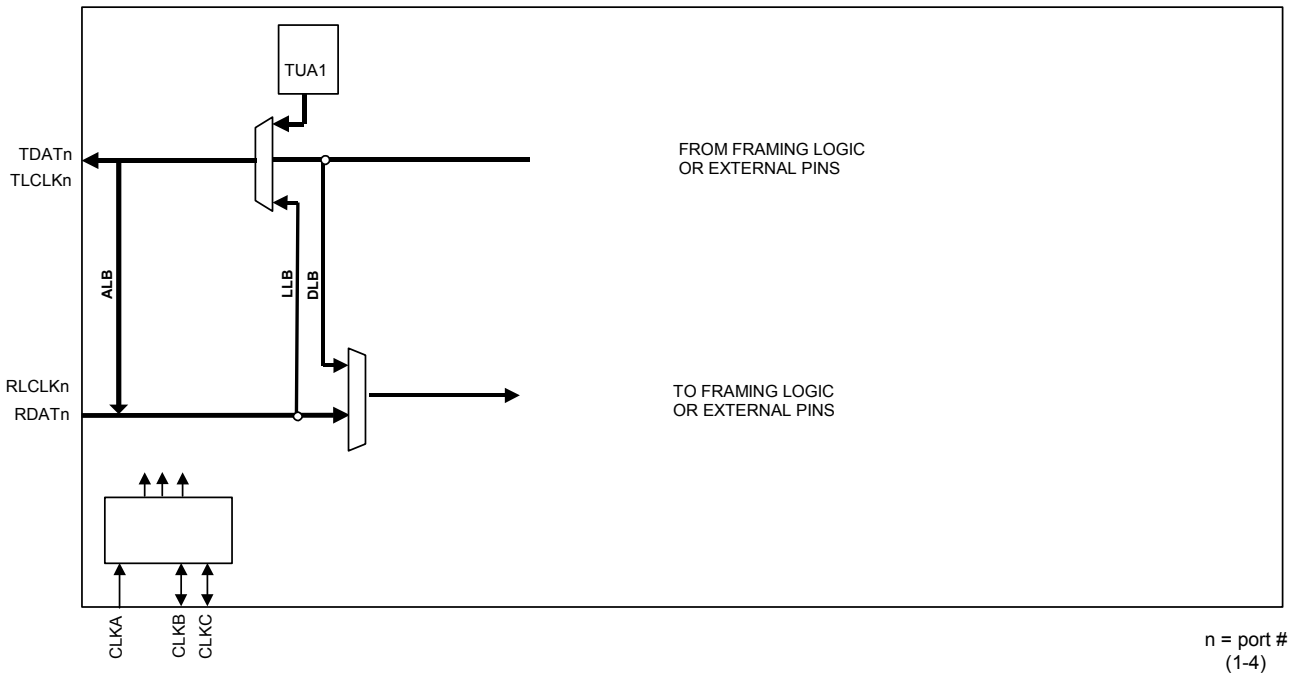

8 PIN DESCRIPTIONS

Note: In JTAG mode, all digital pins are bidirectional to increase the effectiveness of board level ATPG patterns for isolation of interconnect failures.

8.1 Short Pin Descriptions

Table 8-1. DS3174 Short Pin Descriptions

n=1,2,3,4 (port number); Ipu (input with pullup), Oz (output tri-stateable), (needs an external pullup or pulldown resistor to keep from floating), Oa (Analog output), Ia (Analog input), IO (Bidirectional inout); all unused input pins without pullup should be tied low.

NAME	TYPE	FUNCTION	PIN #			
			PORT 4	PORT 3	PORT 2	PORT 1
Line IO						
TLCLKn	O	Transmit Line Clock Output	V11	C11	Y8	A8
TPOSn / TDATn	O	Transmit Positive AMI / Data	V14	C14	V4	C4
TNEGn	O	Transmit Negative AMI	W14	B14	U4	D4
TXPn	Oa	Transmit Positive analog	W6	B6	M2	J2
TXNn	Oa	Transmit Negative analog	Y6	A6	M1	J1
RLCLKn	I	Receive Clock Input	Y12	A12	W8	B8
RXPn	Ia	Receive Positive analog	W5	B5	R2	F2
RXNn	Ia	Receive Negative analog	Y5	A5	R1	F1
RPOSn / RDATn	Ia	Positive AMI / Data	W15	B15	Y3	A3
RNEGn / RLCVn	Ia	Negative AMI / Line Code Violation	Y15	A15	W3	B3
DS3/E3 Overhead Interface						
TOHn	I	Transmit Overhead	U11	D11	U8	D8
TOHENn	I	Transmit Overhead Enable	T14	E14	T5	E5
TOHCLKn	O	Transmit Overhead Clock	T11	E11	V8	C8
TOHSOFn	O	Transmit Overhead Start Of Frame	T12	E12	V7	C7
ROHn	O	Receive Overhead	T10	E10	U10	D10
ROHCLKn	O	Receive Overhead Clock	T13	E13	U5	D5
ROHSOFn	O	Receive Overhead Start Of Frame	U14	D14	Y2	B2
DS3/E3 Serial Data						
TCLKIn	I	Transmit Line Clock Input	Y14	A14	W4	B4
TSOFIn	I	Transmit Start Of Frame Input	U12	D12	W7	B7
TSERn	I	Transmit Serial Data	V13	C13	T6	E6
TCLKOn / TGCLKn	O	Transmit Clock Output / Gapped Clock	Y13	A13	U7	D7
TSOFOn / TDENn	O	Transmit Framer Start Of Frame / Data Enable	V12	C12	Y7	A7
RSERn	O	Receive Serial Data	W11	B11	T9	E9
RCLKOn / RGCLKn	O	Receive / Clock Output / Gapped Clock	Y11	A11	U9	D9
RSOFOn / RDENn	O	Receive Framer Start Of Frame / Data Enable	W12	B12	T8	E8

NAME	TYPE	FUNCTION	PIN #
Microprocessor Interface			
D[15] D[14] D[13] D[12] D[11] D[10] D[9] D[8] D[7] D[6] D[5] D[4] D[3] D[2] D[1] D[0]	IO	Data [15:0]	J5 T4 R4 P4 N4 V3 U3 T3 P3 N3 W2 U2 T2 P2 U1 P1
A[10] A[9] A[8] A[7] A[6] A[5] A[4] A[3] A[2] A[1]	I	Address [10:1]	C3 D3 E3 G3 H3 D2 E2 G2 H2 E1
A[0] / BSWAP		Address [0] / Byte Swap	H1
ALE	I	Address Latch Enable	N2
\overline{CS}	I	Chip Select (active low)	L3
\overline{RD} / \overline{DS}	I	Read Strobe (active low) / Data Strobe (active low)	K3
\overline{WR} / $\overline{R/W}$	I	Write Strobe (active low) / R/W Select	K4
\overline{RDY}	Oz	Ready handshake (active low)	K2
\overline{INT}	Oz	Interrupt (active low)	L4
MODE	I	Mode select RD/WR or DS strobe mode	B1
WIDTH	I	WIDTH select 8 or 16-bit interface	L5
Misc I/O			
GPIO[8] GPIO[7] GPIO[6] GPIO[5] GPIO[4] GPIO[3] GPIO[2] GPIO[1]	IO	General-Purpose IO [8:1]	V2 V1 C2 C1 P5 R5 G5 F5
TEST	I	Test enable (active low)	M3
HIZ	I	High impedance test enable (active low)	R3
\overline{RST}	I	Reset (active low)	B16
JTAG			
JTCLK	I	JTAG Clock	F3
JTMS	Ipu	JTAG Mode Select (with pull-up)	F4
JTDI	Ipu	JTAG Data Input (with pull-up)	J3
JTDO	Oz	JTAG Data Output	G4

NAME	TYPE	FUNCTION	PIN #
JTRST	Ipu	JTAG Reset (active low with pull-up)	E4
CLAD			
CLKA	I	Clock A	K1
CLKB	IO	Clock B	L1
CLKC	IO	Clock C	L2
POWER			
VSS	PWR	Ground, 0 Volt potential	K10, K9, K8, J10, J9, J8, H10, H9, M7, M6, L7, L6, K7, K6, J7, J6, A1, N10, N9, M10, M9, M8, L10, L9, L8, R12, R11, R10, R9, P12, P11, P10, P9, Y1, N12, N11, M13, M12, M11, L13, L12, L11, M15, M14, L15, L14, K15, K14, J15, J14, Y20, K13, K12, K11, J13, J12, J11, H12, H11, G12, G11, G10, G9, F12, F11, F10, F9, A20
VDD	PWR	Digital 3.3V	H8, H7, H6, G8, G7, G6, F8, F7, F6, A2, R8, R7, R6, P8, P7, P6, N8, N7, N6, W1, R15, R14, R13, P15, P14, P13, N15, N14, N13, Y19, H15, H14, H13, G15, G14, G13, F15, F14, F13, B20
AVDDRn	PWR	Analog 3.3V for receive LIU on port n	Y4, A4, T1, D1
AVDDTn	PWR	Analog 3.3V for transmit LIU on port n	T7, E7, N1, J4
AVDDJn	PWR	Analog 3.3V for jitter attenuator on port n	V6, C6, N5, G1
AVDDC	PWR	Analog 3.3V for CLAD	K5
No Connects			
NC	NC	No Connect, Unused	A9, A10, A16–A19, B9, B10, B13, B17–B19, C5, C9, C10, C15–C20, D6, D13, D15–D20, E15–E20, F16–F20, G16–G20, H4, H5, J16–J20, K16–K20, L16–L20, M4, M5, M16–M20, N16–N20, P16–P20, R16–R20, T15–T20, U6, U13, U15–U20, V5, V9, V10, V16–V20, W9, W10, W13, W16–W20, Y9, Y10, Y15–Y18

8.2 Detailed Pin Descriptions

Table 8-2. Detailed Pin Descriptions

n=1,2,3,4 (port number); Ipu (input with pullup), Oz (output tri-stateable) (needs an external pullup or pulldown resistor to keep from floating), Oa (Analog output), Ia (analog input), IO (Bidirectional inout); all unused input pins without pullup should be tied low.

PIN NAME	TYPE	PIN DESCRIPTION
LINE IO		
TLCLKn	O	<p>Transmit Line Clock Output</p> <p>TLCLKn: This signal is available when the transmit line interface pins are enabled (PORT.CR2.TLEN). This clock is typically used as the clock reference for the TDATn and TNEG signals, but can also be used as the reference for the TSOFin, TSErn, and TSOFO n / TDENn signals.</p> <p>This output signal can be inverted.</p> <ul style="list-style-type: none"> o DS3: 44.736 MHz +20 ppm o E3: 34.368 MHz +20 ppm
TPOSn / TDATn	O	<p>Transmit Positive AMI / Data Output</p> <p>TPOSn: When the port line interface is configured for B3ZS, HDB3 or AMI mode and the transmit line interface pins are enabled (PORT.CR2.TLEN), a high on this pin indicates that a positive pulse should be transmitted on the line. The signal is updated on the positive clock edge of the referenced clock pin if the clock pin signal is not inverted, otherwise it is updated on the falling edge of the clock. The signal is typically referenced to the TLCLKn line clock output pins, but it can be referenced to the TCLKOn, TCLKIn, RLCLKn or RCLKOn pins. This output signal can be disabled when the TX LIU is enabled.</p> <p>This output signal can be inverted.</p> <p>TDATn: When the port line interface is configured for UNI mode and the transmit line interface pins are enabled (PORT.CR2.TLEN), the un-encoded transmit signal is output on this pin. The signal is updated on the positive clock edge of the referenced clock pin if the clock pin signal is not inverted, otherwise it is updated on the falling edge of the clock. The signal is typically referenced to the TLCLK line clock output pins, but it can be referenced to the TCLKOn, TCLKIn, RLCLKn or RCLKOn pins</p> <p>This output signal can be inverted.</p> <ul style="list-style-type: none"> o DS3: 44.736 Mbps +20ppm o E3: 34.368 Mbps +20ppm
TNEGn	O	<p>Transmit Negative AMI / Line OH Mask</p> <p>TNEGn: When the port line interface is configured for B3ZS, HDB3 or AMI mode and the transmit line interface pins are enabled (PORT.CR2.TLEN), a high on this pin indicates that a negative pulse should be transmitted on the line. The signal is updated on the positive clock edge of the referenced clock pin if the clock pin signal is not inverted, otherwise it is updated on the falling edge of the clock. The signal is typically referenced to the TLCLKn line clock output pins, but it can be referenced to the TCLKOn, TCLKIn, RLCLKn or RCLKOn pins.</p> <p>This output signal can be inverted.</p> <ul style="list-style-type: none"> o DS3: 44.736 Mbps +20ppm o E3: 34.368 Mbps +20ppm
TXPn	Oa	<p>Transmit Positive Analog</p> <p>TXPn: This pin and the TXNn pin form a differential AMI output which is coupled to the outbound 75Ω coaxial cable through a 2:1 step-down transformer (Figure 1-1). This output is enabled when the TX LIU is enabled and the output is enabled to be driven. When it is not enabled, it is in a high impedance state.</p> <ul style="list-style-type: none"> o DS3: 44.736 Mbps +20ppm o E3: 34.368 Mbps +20ppm
TXNn	Oa	<p>Transmit Negative Analog</p> <p>TXNn: This pin and the TXPn pin form a differential AMI output which is coupled to the outbound 75Ω coaxial cable through a 2:1 step-down transformer (Figure 1-1). This output is enabled when the TX LIU is enabled and the output is enabled to be driven. When it is not enabled, it is in a high impedance state.</p> <ul style="list-style-type: none"> o DS3: 44.736 Mbps +20ppm o E3: 34.368 Mbps +20ppm

PIN NAME	TYPE	PIN DESCRIPTION
RXPn	Ia	Receive Positive analog RXPn: This pin and the RXNn pin form a differential AMI input which is coupled to the outbound 75Ω coaxial cable through a 2:1 step-up transformer (Figure 1-1). This input is used when the RX LIU is enabled and is ignored when the LIU is disabled. <ul style="list-style-type: none"> ○ DS3: 44.736 Mbps \pm20ppm ○ E3: 34.368 Mbps \pm20ppm
RXNn	Ia	Receive Negative analog RXNn: This pin and the RXPn pin form a differential AMI input which is coupled to the outbound 75Ω coaxial cable through a 2:1 step-up transformer (Figure 1-1). This input is used when the LIU is enabled and is ignored when the LIU is disabled. <ul style="list-style-type: none"> ○ DS3: 44.736 Mbps \pm20ppm ○ E3: 34.368 Mbps \pm20ppm
RLCLKn	I	Receive Line Clock Input RLCLKn: This clock is typically used for the reference clock for the RPOSn / RDATn, RNEGn / RLCVn signals but can also be used as the reference clock for the RSERn, RSOFO n / RDENn, TSOFO n, TSERn, TSOFO n / TDENn, TPOSn / TDATn and TNEGn signals. This input is ignored when the LIU is enabled. This input signal can be inverted. <ul style="list-style-type: none"> ○ DS3: 44.736 MHz \pm20 ppm ○ E3: 34.368 MHz \pm20 ppm
RPOSn / RDATn	Iad	Receive Positive AMI / Data RPOSn: When the port line is configured for B3ZS, HDB3 or AMI mode and the LIU is disabled, a high on this pin indicates that a positive pulse has been detected using an external LIU. The signal is sampled on the positive clock edge of the referenced clock pin if the clock pin signal is not inverted, otherwise it is sampled on the falling edge of the clock. The signal is typically referenced to the RLCLKn line clock input pins, but it can be referenced to the RCLKOn output pins. This input signal can be inverted. RDATn: When the port line interface is configured for UNI mode, the un-encoded receive signal is input on this pin. The signal is sampled on the positive clock edge of the referenced clock pin if the clock pin signal is not inverted, otherwise it is sampled on the falling edge of the clock. The signal is typically referenced to the RLCLKn line clock input pins, but it can be referenced to the RCLKOn output pins. This input signal can be inverted. <ul style="list-style-type: none"> ○ DS3: 44.736 Mbps \pm20ppm ○ E3: 34.368 Mbps \pm20ppm
RNEGn / RLCVn	Iad	Receive Negative AMI / Line Code Violation / Line OH Mask input RNEGn: When the port line is configured for B3ZS, HDB3 or AMI mode and the LIU is disabled, a high on this pin indicates that a negative pulse has been detected using an external LIU. The signal is sampled on the positive clock edge of the referenced clock pin if the clock pin signal is not inverted, otherwise it is sampled on the falling edge of the clock. The signal is typically referenced to the RLCLKn line clock input pins, but it can be referenced to the RCLKOn output pins. This input signal can be inverted. <ul style="list-style-type: none"> ○ DS3: 44.736 Mbps \pm20ppm ○ E3: 34.368 Mbps \pm20ppm RLCVn: When the port line interface is configured for UNI mode, the BPV counter in the encoder/decoder block is incremented each clock when this signal is high. The signal is sampled on the positive clock edge of the referenced clock pin if the clock pin signal is not inverted, otherwise it is sampled on the falling edge of the clock. The signal is typically referenced to the RLCLKn line clock input pins, but it can be referenced to the RCLKOn output pins. This input signal can be inverted.

PIN NAME	TYPE	PIN DESCRIPTION
DS3/E3 OVERHEAD INTERFACE		
TOHn	I	<p>Transmit Overhead</p> <p>TOHn: When the port framer is configured for one of the DS3 or E3 framing modes, this signal will be used to over-write the DS3 or E3 framing overhead bits when TOHENn is active. In T3 mode, the X-bits, P-bits, M-bits, F-bits, and C-bits are input. In G.751 E3 mode, all of the FAS, RAI, and National Use bits are input. In G.832 E3 mode, all of the FA1, FA2, EM, TR, MA, NR, and GC bytes are input. The TOHSOFn signal marks the start of the framing bit sequence. This signal is sampled at the same time as the TOHCLKn signal transitions high to low. This signal can be inverted.</p>
TOHENn	I	<p>Transmit Overhead Enable / Start Of Frame Input</p> <p>TOHENn: When the port framer is configured for one of the DS3 or E3 framing modes, this signal will be used to determine which DS3 or E3 framing overhead bits to over-write with the signal on the TOHn pins. The TOHSOFn signal marks the start of the framing bit sequence. This signal is sampled at the same time as the TOHCLKn signal transitions high to low. This signal can be inverted.</p>
TOHCLKn	O	<p>Transmit Overhead Clock</p> <p>TOHCLKn: When the port framer is configured for one of the DS3 or E3 framing modes, this clock is used for the transmit overhead port signals TOHn, TOHENn and TOHSOFn. The TOHSOFn output signal is updated and the TOHn and TOHENn input signals are sampled at the same time this clock signal transitions from high to low. The external logic is expected to sample TOHSOFn signal and update the TOHn and TOHENn signals on the rising edge of this clock signal. This clock is a low frequency clock. This signal can be inverted.</p>
TOHSOFn	O	<p>Transmit Overhead Start Of Frame</p> <p>TOHSOFn: When the port framer is configured for one of the DS3 or E3 framing modes, this signal is used to mark the start of a DS3 or E3 overhead sequence on the TOHn pins. In T3 mode, the first X-bit is marked. In G.751 E3 mode, the first bit of the FAS word is marked. In G.832 E3 mode, the first bit of the FA1 byte is marked. The sequence starts on the same high to low transition of the TOHCLKn clock that this signal is high. This signal is updated at the same time as the TOHCLKn signal transitions high to low. This signal can be inverted.</p>
ROHn	O	<p>Receive Overhead</p> <p>ROHn: When the port framer is configured for one of the DS3 or E3 framing modes, this signal outputs the value of the receive overhead bits. The ROHSOFn signal marks the start of the framing bit sequence. In T3 mode, the X-bits, P-bits, M-bits, F-bits, and C-bits are output (Note: In M23 mode, the C-bits are extracted even though they are marked as data at the payload interface). In G.751 E3 mode, all of the FAS, RAI, and National Use bits are output. In G.832 E3 mode, all of the FA1, FA2, EM, TR, MA, NR, and GC bytes are output. This signal is updated at the same time as the ROHCLKn signal transitions high to low. This signal can be inverted.</p>
ROHCLKn	O	<p>Receive Overhead Clock</p> <p>ROHCLKn: When the port framer is configured for one of the DS3 or E3 framing modes, this clock is used for the receive overhead port signals ROHn and ROHSOFn. The ROHSOFn and ROHn output signals are updated at the same time this clock signal transitions from high to low. The external logic is expected to sample ROHSOFn and ROHn signal on the rising edge of this clock signal. This clock is a low frequency clock. This signal can be inverted.</p>
ROHSOFn	O	<p>Receive Overhead Start Of Frame</p> <p>ROHSOFn: When the port framer is configured for one of the DS3 or E3 framing modes this signal is used to mark the start of a DS3 or E3 overhead sequence on the ROHn pins. In T3 mode, the first X-bit is marked. In G.751 E3 mode, the first bit of the FAS word is marked. In G.832 E3 mode, the first bit of the FA1 byte is marked. The sequence starts on the same high to low transition of the ROHCLKn clock that this signal is high. This signal is updated at the same time as the ROHCLKn signal transitions high to low. This signal can be inverted.</p>

PIN NAME	TYPE	PIN DESCRIPTION
DS3/E3 SERIAL DATA OVERHEAD INTERFACE		
TCLKIn	I	<p>Transmit Line Clock Input</p> <p>TCLKIn: This clock is typically used for the reference clock for the TSOFIn, TSERn, and TSOFOn / TDENn signals but can also be used as the reference for the TPOSn / TDATn and TNEGn signals. This clock is not used when the part is in loop time mode or the CLAD clocks are used as the transmit clock source. (<i>PORT.CR3.CLADC</i>)</p> <p>This input signal can be inverted.</p> <ul style="list-style-type: none"> ○ DS3: 44.736 MHz ± 20 ppm ○ E3: 34.368 MHz ± 20 ppm
TSOFIn	I	<p>Transmit Start Of Frame Input</p> <p>See Table 10-20.</p> <p>TSOFIn: This signal can be used to align the start of the DS3 or E3 frames on the TSERn pin to an external signal. In SCT modes, the TSOFIn signal can be used to align the start of frame signal position on the TSERn/TOHn</p> <p>Pin to the rising edge of a signal on this pin. The signal edge does not need to occur on every frame and can be tied high or low. The signal is sampled on the positive clock edge of the referenced clock pin if the clock pin signal is not inverted, otherwise it is sampled on the falling edge of the clock. The signal is typically referenced to the TCLKIn transmit clock input pins, but it can be referenced to the TLCLKn, TCLKOn, RCLKOn and RLCLKn clock pins.</p> <p>This signal can be inverted.</p>
TSERn	I	<p>Transmit Serial Data</p> <p>TSERn: When the port framer is configured for either the DS3 or E3 SCT modes, this pin is used as the source of the DS3/E3 payload data. When the port is configured for a clear channel mode, this pin is used as the source of the DS3/E3 data signal. The signal is sampled on the positive clock edge of the referenced clock pin if the clock pin signal is not inverted, otherwise it is sampled on the falling edge of the clock. The signal is typically referenced to the TCLKIn transmit clock input pins, but it can be referenced to the TLCLKn, TCLKOn / TGCLKn, RCLKOn and RLCLKn clock pins</p> <p>This signal can be inverted.</p> <ul style="list-style-type: none"> ○ DS3: 44.736 Mbps ± 20ppm ○ E3: 34.368 Mbps ± 20ppm
TCLKOn / TGCLKn	O	<p>Transmit Clock Output / Gapped Clock</p> <p>See Table 10-22.</p> <p>TCLKOn: When the port is configured for unframed SCT or framed SCT modes and TCLKOn is selected, this clock output is enabled. This clock is the same clock as the internal framer transmit clock. This clock is typically used for the reference clock for the TSOFIn, TSERn, and TSOFOn / TDENn signals but can also be used as the reference for the TPOSn / TDATn and TNEGn signals.</p> <p>This signal can be inverted.</p> <ul style="list-style-type: none"> ○ DS3: 44.736 MHz ± 20 ppm ○ E3: 34.368 MHz ± 20 ppm <p>TGCLKn: When the port is configured for framed DS3/E3 mode and TGCLKn is selected, this gated output clock is enabled. This gapped clock is the same clock as the internal framer transmit clock and is gated by TDENn. This clock is typically used for the reference clock for the TSERn signal.</p> <p>This signal can be inverted.</p>

PIN NAME	TYPE	PIN DESCRIPTION
TSOFOn / TDENn	O	<p>Framer Start Of Frame / Data Enable See Table 10-21.</p> <p>TSOFOn: When the port framer is configured for the DS3 or E3 framed modes and the TSOFOn pin function is selected, this signal is used to indicate the start of the DS3/E3 frame on the TSERn pin. This signal pulses high three clocks before the first overhead bit in a DS3 or E3 frame that will be input on TSERn. The signal is updated on the positive clock edge of the referenced clock pin if the clock pin signal is not inverted, otherwise it is updated on the falling edge of the clock. The signal is typically referenced to the TCLKIn transmit clock input pins, but it can be referenced to the TLCLKn, TCLKOn, RCLKOn and RLCLKn clock pins. This signal can be inverted.</p> <p>TDENn: When the port framer is configured for the DS3 or E3 framed modes and the TDENn pin function is selected, this signal is used to mark the DS3/E3 frame bits on the TSERn pin. The signal goes high three clocks before the start of DS3/E3 payload bits and goes low three clocks before the end of the DS3/E3 payload bits. The signal is updated on the positive clock edge of the referenced clock pin if the clock pin signal is not inverted, otherwise it is updated on the falling edge of the clock. The signal is typically referenced to the TCLKIn transmit clock input pins, but it can be referenced to the TLCLKn, TCLKOn, RCLKOn and RLCLKn clock pins. This signal can be inverted.</p>
RSERn	O	<p>Receive Serial Data</p> <p>RSERn: When the port framer is configured for the DS3 or E3 framed modes, this pin outputs the receive data signal from the LIU or receive line pins. The signal is updated on the positive clock edge of the referenced clock pin if the clock pin signal is not inverted, otherwise it is updated on the falling edge of the clock. The signal is typically referenced to the RCLKOn receive clock output pin, but it can be referenced to the RGCLKn and RLCLKn clock pins. This signal can be inverted</p> <ul style="list-style-type: none"> o DS3: 44.736 Mbps ± 20ppm o E3: 34.368 Mbps ± 20ppm
RCLKOn / RGCLKn	O	<p>Receive Clock Output / Gapped Clock See Table 10-24.</p> <p>RCLKOn: When the port framer is configured for the DS3 or E3 framed modes and RCLKOn is selected, this clock output signal is active. It is the same as the internal receive framer clock. This clock is typically used for the reference clock for the RSERn, RSOFOn / RDENn signals but can also be used as the reference for the RPOSn / RDATn, RNEGn / RLCVn, TSOFIn, TSERn, TSOFOn / TDENn, TPOSn / TDATn and TNEGn signals. This signal can be inverted.</p> <ul style="list-style-type: none"> o DS3: 44.736 MHz ± 20 ppm o E3: 34.368 MHz ± 20 ppm <p>RGCLKn: When the port is configured for DS3/E3 framed mode and RGCLKn is selected, this gated clock output signal is active. It is the same as the internal receive framer clock gated by RDENn. This clock is typically used for the reference clock for the RSERn. This signal can be inverted</p>
RSOFOn / RDENn	O	<p>Receive Framer Start Of Frame /Data Enable See Table 10-23.</p> <p>RSOFOn: When the port framer is configured for the DS3 or E3 framed modes and the RSOFOn pin function is enabled, this signal is used to indicate the start of the DS3/E3 frame. This signal indicates the first DS3/E3 overhead bit on the RSERn pin when high. The signal is updated on the positive clock edge of the referenced clock pin if the clock pin signal is not inverted, otherwise it is updated on the falling edge of the clock. The signal is typically referenced to the RCLKOn receive clock output pin, but it can be referenced to the RLCLKn clock input pin. This signal can be inverted.</p> <p>RDENn: When the port framer is configured for the DS3 or E3 framed modes and the RDENn pin function is enabled, this signal is used to indicate the DS3/E3 payload bit positions of the data on the RSERn pin. The signal goes high during each DS3/E3 payload bit and goes low during each DS3/E3 overhead bit. The signal is updated on the positive clock edge of the referenced clock pin if the clock pin signal is not inverted, otherwise it is updated on the falling edge of the clock. The signal is typically referenced to the RCLKOn receive clock output pin, but it can be referenced to the RLCLKn clock input pin. This signal can be inverted.</p>

PIN NAME	TYPE	PIN DESCRIPTION
MICROPROCESSOR INTERFACE		
D[15:0]	IO	Bi-directional 16 or 8-bit data bus This bus is tri-state when $\overline{\text{RST}}$ pin is low or $\overline{\text{CS}}$ pin is high. D[15:0]: A 16-bit or 8-bit data bus used to input data during register writes, and data outputs during register reads. The upper 8 bits are not used and never driven in 8-bit bus mode. Weak pull up resistors or bus holders should be used for each pin.
A[10:1]	I	Address bus (minus LSB) A[10:1]: identifies the specific 16 bit registers, or group of 8 bit registers, being accessed. A[10] must be tied to ground for the DS3181 and DS3182 versions.
A[0] / BSWAP		Address bus LSB / Byte Swap A[0]: This signal is connected to the lower address bit in 8-bit systems. (WIDTH=0) 1 = Output register bits 15:8 on D[7:0], D[15:8] not driven 0 = Output register bits 7:0 on D[7:0], D[15:8] not driven BSWAP: This signal is tied high or low in 16-bit systems. (WIDTH=1) 1 = Output register bits 15:8 on D[7:0], 7:0 on D[15:8] 0 = Output register bits 7:0 on D[7:0], 15:8 on D[15:8]
ALE	I	Address Latch Enable ALE: This signal is used to latch the address on the A[10:0] pins in multiplexed address systems. When it is high the address is fed through the address latch to the internal logic. When it transitions to low, the address is latched and held internally until the signal goes back high. ALE should be tied high for non-multiplexed address systems.
$\overline{\text{CS}}$	I	Chip Select (active low) $\overline{\text{CS}}$: This signal must be low during all accesses to the registers
$\overline{\text{RD}}$ / $\overline{\text{DS}}$	I	Read Strobe (active low) / Data Strobe (active low) $\overline{\text{RD}}$: Read Strobe mode (MODE=0): $\overline{\text{RD}}$ is low during a register read. $\overline{\text{DS}}$: Data Strobe mode (MODE=1): $\overline{\text{DS}}$ is low during either a register read or a write.
$\overline{\text{WR}}$ / R/W	I	Write Strobe (active low) / R/W Select $\overline{\text{WR}}$: Write Strobe mode (MODE=0): $\overline{\text{WR}}$ is low during a register write. R/W: Data Strobe mode (MODE=1): R/W is high during a register read cycle, and low during a register write cycle.
$\overline{\text{RDY}}$	Oz	Ready handshake (active low) $\overline{\text{RDY}}$: This ready signal is driven low when the current read or write cycle is in progress. When the current read or write cycle is not ready it is driven high. When device is not selected, it is not driven.
$\overline{\text{INT}}$	Oz	Interrupt (active low) This signal is tri-state when $\overline{\text{RST}}$ pin is low. $\overline{\text{INT}}$: This interrupt signal is driven low when an event is detected on any of the enabled interrupt sources in any of the register banks. When there are no active and enabled interrupt sources, the pin can be programmed to either drive high or not drive high. The reset default is to not drive high when there is no active and enabled interrupt source. All interrupt sources are disabled when $\overline{\text{RST}}=0$ and they must be programmed to be enabled.
MODE	I	Mode select $\overline{\text{RD}}/\overline{\text{WR}}$ or $\overline{\text{DS}}$ strobe mode MODE: 1 = Data Strobe Mode, 0 = Read/Write Strobe Mode
WIDTH	I	Data bus width select 8 or 16-bit interface WIDTH: 1 = 16-bits, 0 = 8 bits

PIN NAME	TYPE	PIN DESCRIPTION
MISC I/O		
GPIO1	IO	General-Purpose IO 1 GPIO1: This signal is configured to be a general-purpose IO pin, or an alarm output signal for port 1.
GPIO2	IO	General-Purpose IO 2 GPIO2: This signal is configured to be a general-purpose IO pin, or the 8KREFO output signal, or an alarm output signal for port 1.
GPIO3	IO	General-Purpose IO 3 GPIO3: This signal is configured to be a general-purpose IO pin, or an alarm output signal for port 2.
GPIO4	IO	General-Purpose IO 4 GPIO4: This signal is configured to be a general-purpose IO pin, or the 8KREFI input signal, or an alarm output signal for port 2. When configured for 8KREFI mode the signal frequency should be 8,000 Hz +/- 500 ppm and about 50% duty cycle.
GPIO5	IO	General-Purpose IO 5 GPIO5: This signal is configured to be a general-purpose IO pin, or an alarm output signal for port 3.
GPIO6	IO	General-Purpose IO 6 GPIO6: This signal is configured to be a general-purpose IO pin, or the TMEI input signal, or an alarm output signal for port 3. When configured for TMEI input, the signal low time and high time must be greater than 500 ns.
GPIO7	IO	General-Purpose IO 7 GPIO7: This signal is configured to be a general-purpose IO pin, or an alarm output signal for port 4.
GPIO8	IO	General-Purpose IO 8 GPIO8: This signal is configured to be a general-purpose IO pin, or the PMU input signal, or an alarm output signal for port 4. When configured for PMU input, the signal low time and high time must be greater than 500 ns.
$\overline{\text{TEST}}$	I	Test enable (active low) $\overline{\text{TEST}}$: This signal enables the internal scan test mode when low. For normal operation tie high. This is an asynchronous input.
$\overline{\text{HIZ}}$	I	High impedance test enable (active low) $\overline{\text{HIZ}}$: This signal puts all digital output and bi-directional pins in the high impedance state when it low and $\overline{\text{JTRST}}$ is low. For normal operation tie high. This is an asynchronous input.
$\overline{\text{RST}}$	I	Reset (active low) $\overline{\text{RST}}$: This signal resets all the internal processor registers and logic when low. This pin should be low while power is applied and set high after the power is stable. This is an asynchronous input.
JTAG		
JTCLK	I	JTAG Clock JTCLK: This clock input is typically a low frequency (less than 10 MHz) 50% duty cycle clock signal.
JTMS	Ipu	JTAG Mode Select (with pull-up) JTMS: This input signal is used to control the JTAG controller state machine and is sampled on the rising edge of JTCLK.
JTDI	Ipu	JTAG Data Input (with pull-up) JTDI: This input signal is used to input data into the register that is enabled by the JTAG controller state machine and is sampled on the rising edge of JTCLK.
JTDO	Oz	JTAG Data Output JTDO: This output signal is the output of an internal scan shift register enabled by the JTAG controller state machine and is updated on the falling edge of JTCLK. The pin is in the high impedance mode when a register is not selected or when the $\overline{\text{JTRST}}$ signal is high. The pin goes into and exits the high impedance mode after the falling edge of JTCLK.
$\overline{\text{JTRST}}$	Ipu	JTAG Reset (active low with pullup) $\overline{\text{JTRST}}$: This input forces the JTAG controller logic into the reset state and forces the JTDO pin into high impedance when low. This pin should be low while power is applied and set high after the power is stable. The pin can be driven high or low for normal operation, but must be high for JTAG operation.

PIN NAME	TYPE	PIN DESCRIPTION
CLAD		
CLKA	I	Clock A CLKA: This clock input is a DS3 signal(44.736MHz +/-20ppm) when the CLAD is disabled or it is one of the CLAD reference clock signals when the CLAD is enabled.
CLKB	IO	Clock B CLKB: This pin is a E3(34.368 MHz +/-20 ppm) input signal when the CLAD is disabled or it can be enabled to output a generated clock when the CLAD is enabled. The pin is driven low when it is not selected to output a clock signal and the CLAD is enabled. Refer to Table 10-11 .
CLKC	IO	Clock C CLKC: This pin is a STS-1 (51.84 MHz +/-20ppm) input signal when the CLAD is disabled or it can be enabled to output a generated clock when the CLAD is enabled. The pin is driven low when it is not selected to output a clock signal and the CLAD is enabled. Refer to Table 10-11 .
POWER		
VSS	PWR	Ground, 0 Volt potential Common to digital core, digital IO and all analog circuits
VDD	PWR	Digital 3.3V Common to digital core and digital IO
AVDDRn	PWR	Analog 3.3V for receive LIU on port n Powers receive LIU on port n
AVDDTn	PWR	Analog 3.3V for transmit LIU on port n Powers transmit LIU on port n
AVDDJn	PWR	Analog 3.3V for jitter attenuator on port n Powers jitter attenuator on port n
AVDDC	PWR	Analog 3.3V for CLAD Powers clock rate adapter common to all ports

8.3 Pin Functional Timing

8.3.1 Line IO

8.3.1.1 B3ZS/HDB3/AMI Mode Transmit Pin Functional Timing

There is no suggested time alignment between the TXPn, TXNn and TX LINE signals and the TLCLKn clock signal. The TX DATA signal is not a readily available signal, it is meant to represent the data value of the other signals.

The TXPn and TXNn signals are only available when the line is in B3ZS/HDB3 or AMI mode and the LIU is enabled. The TPOSn, TNEGn and TLCLKn signals are only available when the line is in B3ZS/HDB3 or AMI mode and the transmit line pins are enabled. The TPOSn, TNEGn and TLCLKn pins can be enabled at the same as the LIU is enabled.

The TPOSn and TNEGn signals change a small delay after the positive edge of the reference clock if the clock pin is not inverted; otherwise they change after the negative edge. The TLCLKn clock pin is the clock reference typically used for the TPOSn and TNEGn signals, but they can be time referenced to the TCLKIn, TCLKOn, RLCLKn or RCLKOn clock pins. The TPOSn and TNEGn pins can be inverted, but the polarity of TXPn and TXNn cannot be inverted.

TXPn and TXNn are differential analog output pins. They are biased around $\frac{1}{2}$ VDD and pulse above and below the bias voltage by about 1 Volt. These signals are connected to the windings of a 1:2 step down transformer and the other winding of the transformer creates the TX LINE signal. The TX LINE signal is a bipolar signal that pulses about 1 Volt positive and 1 Volt negative above and below ground (0 volts). See [Figure 1-1](#) for a diagram of the external connections.

[Figure 8-1](#) and [Figure 8-2](#) show the relationship between the analog and the digital outputs.

Figure 8-1. TX Line IO B3ZS Functional Timing Diagram

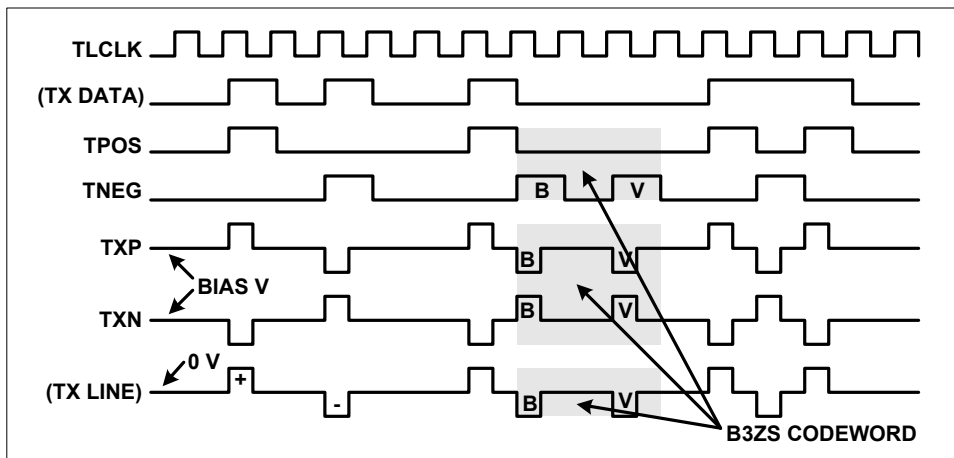
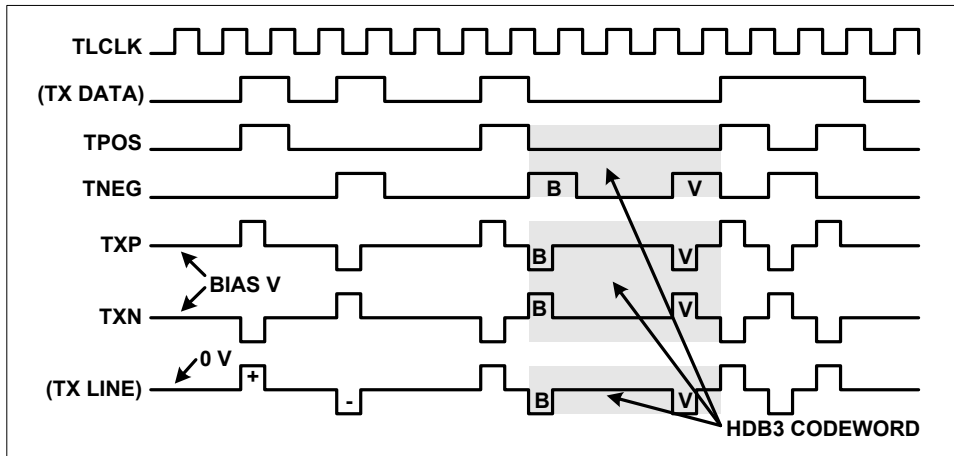

Figure 8-2. TX Line IO HDB3 Functional Timing Diagram**8.3.1.2 B3ZS/HDB3/AMI Mode Receive Pin Functional Timing**

There is no suggested time alignment between the RXPn, RXNn and RX LINE signals and the RLCLKn clock signal. The RX DATA signal is not an always readily available signal, it is meant to represent the data value of the other signals. The signal on RSERn will be the same as the RX DATA signal except delayed.

The RXPn and RXNn pins are only available when the line is in B3ZS/HDB3 or AMI mode and the LIU is enabled. The RPOSn, RNEGn and RLCLKn pins are only available when the line is in B3ZS/HDB3 or AMI mode and the LIU is disabled.

The RPOSn and RNEGn signals are sampled at the rising edge of the reference clock signal if the clock pin is not inverted; otherwise they are sampled at the negative edge. The RLCLKn clock pin is the clock reference used for the RPOSn and RNEGn signals. The RPOSn and RNEGn pins can be inverted.

RXPn and RXNn are differential analog input pins. They are biased around $\frac{1}{2}$ VDD and pulse above and below the bias voltage by about 1 Volt with zero cable length. These signals are connected to the windings of a 1:2 step up transformer and the other winding of the transformer is connected to the RX LINE signal. The RX LINE signal is a bipolar signal that pulses about 1 Volt positive and 1 Volt negative above and below ground (0 volts) with zero cable length. See [Figure 1-1](#) for a diagram of the external connections.

[Figure 8-3](#) and [Figure 8-4](#) show the relationship between the analog and the digital outputs.

Figure 8-3. RX Line IO B3ZS Functional Timing Diagram

Figure 8-4. RX Line IO HDB3 Functional Timing Diagram**8.3.1.3 UNI Mode Transmit Pin Functional Timing**

The TDATn pin is available when the line interface is in the UNI mode and the transmit line pins are enabled.

The TDATn signal changes a small delay after the positive edge of the reference clock signal if the clock pin is not inverted, otherwise they change after the negative edge. The TLCLKn clock pin is the clock reference typically used for the TDATn signal, but the TDATn can be time referenced to the TCLKn, TCLKOn, RLCLKn or RCLKOn clock pins. The TDATn pins can be inverted. See [Figure 8-5](#).

Figure 8-5. TX Line IO UNI Functional Timing Diagram**8.3.1.4 UNI Mode Receive Pin Functional Timing**

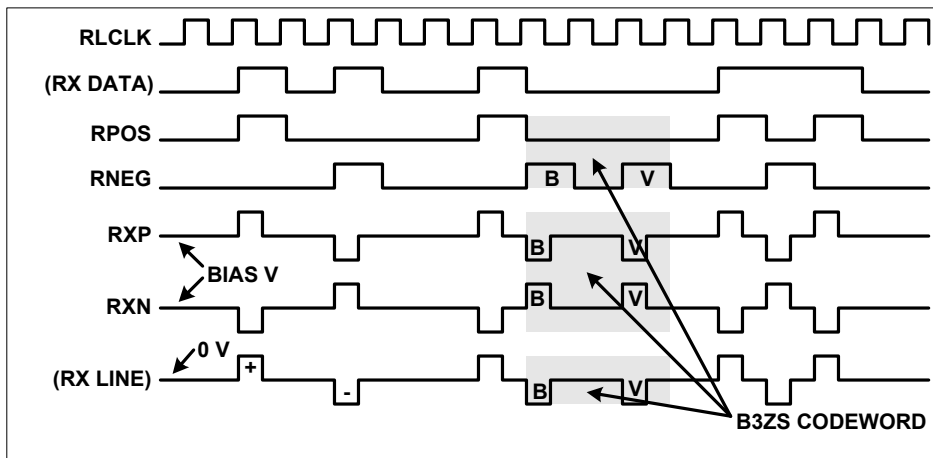
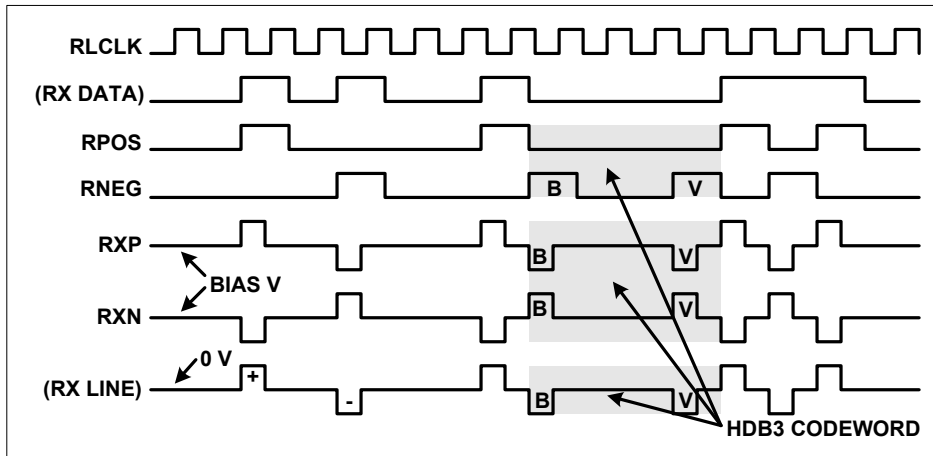
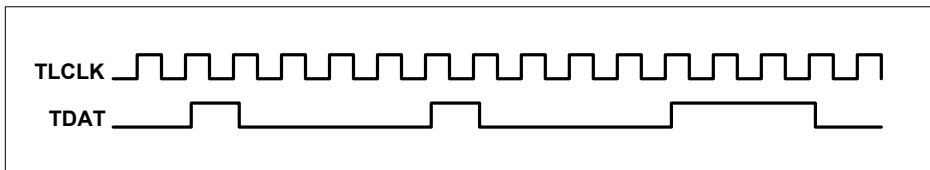
The RDATn pin is available when the line interface is in the UNI mode. The RLCVn pin is available when the line interface is in the UNI.

All bits on the RDATn pin, will come out the RSERn pin, if the RSERn pin is enabled.

The signal on the RLCVn pin enables the BPV counter, which is in the line interface, to increment each clock it is high.

The RDATn and RLCVn signals are sampled at the rising edge of the reference clock signal if the clock pin is not inverted; otherwise they are sampled at the negative edge. The RLCLKn clock pin is the clock reference used for the RDATn and RLCVn signals. The RDATn and RLCVn pins can be inverted. See [Figure 8-6](#).

Figure 8-6. RX Line IO UNI Functional Timing Diagram

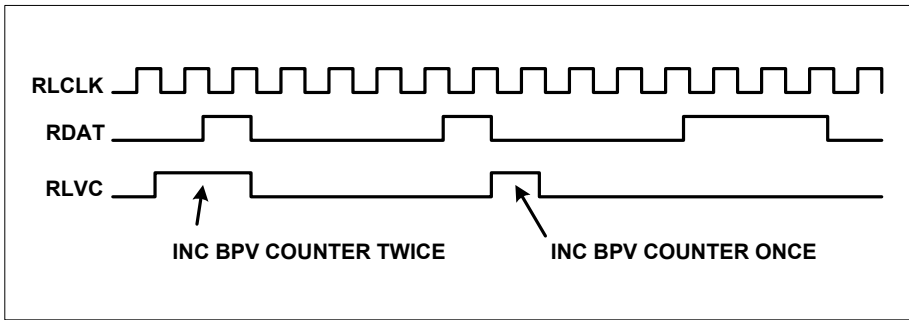

8.3.2 DS3/E3 Framing Overhead Functional Timing

Figure 8-7 shows the relationship between the DS3 receive overhead port pins.

Figure 8-7. DS3 Framing Receive Overhead Port Timing

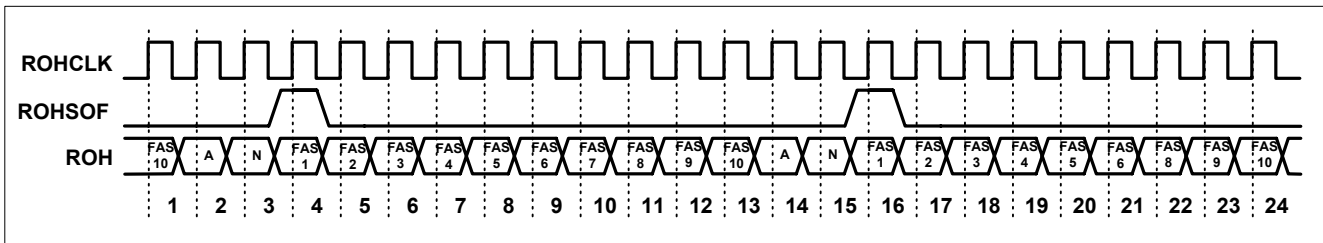

Figure 8-8 shows the relationship between the E3 G.751 receive overhead port pins.

Figure 8-8. E3 G.751 Framing Receive Overhead Port Timing

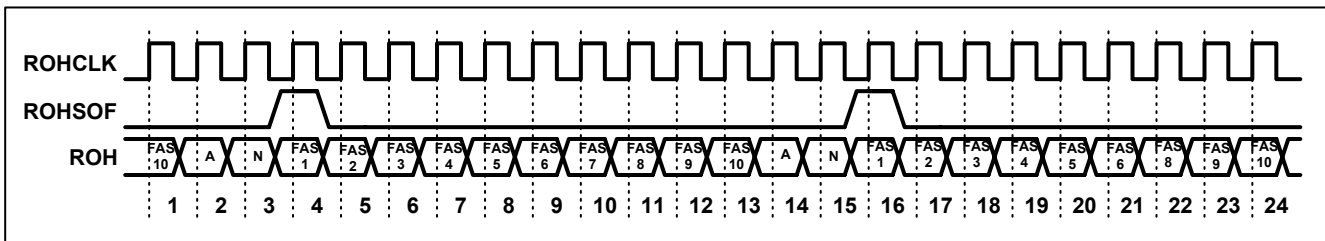

Figure 8-9 shows the relationship between the E3 G.832 receive overhead port pins.

Figure 8-9. E3 G.832 Framing Receive Overhead Port Timing

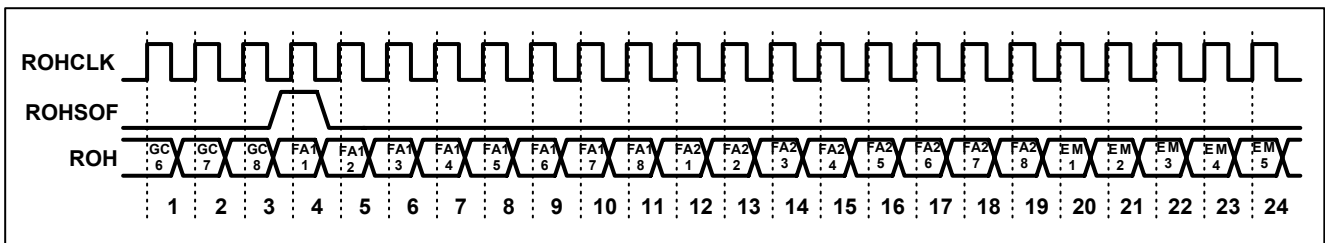

Figure 8-10 shows the relationship between the DS3 transmit overhead port pins.

Figure 8-10. DS3 Framing Transmit Overhead Port Timing

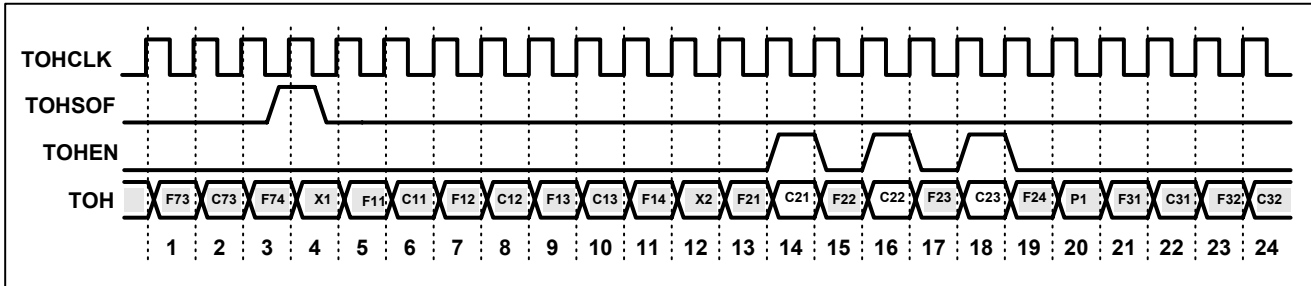

Figure 8-11 shows the relationship between the E3 G.751 transmit overhead port pins.

Figure 8-11. E3 G.751 Framing Transmit Overhead Port Timing

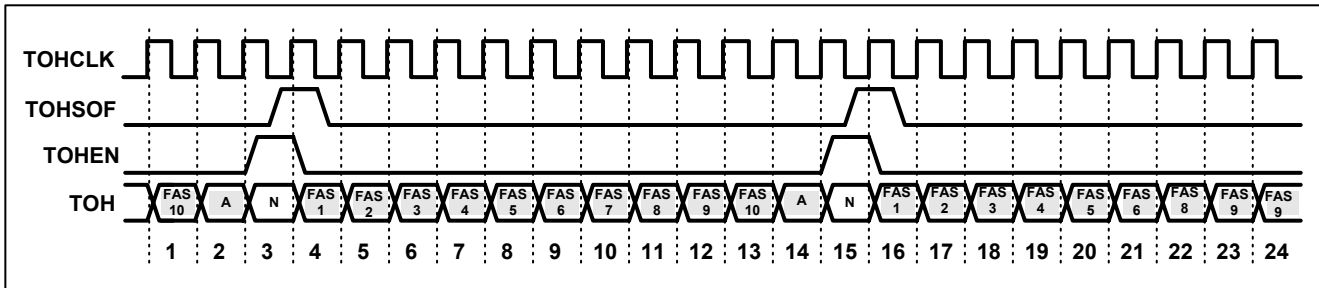
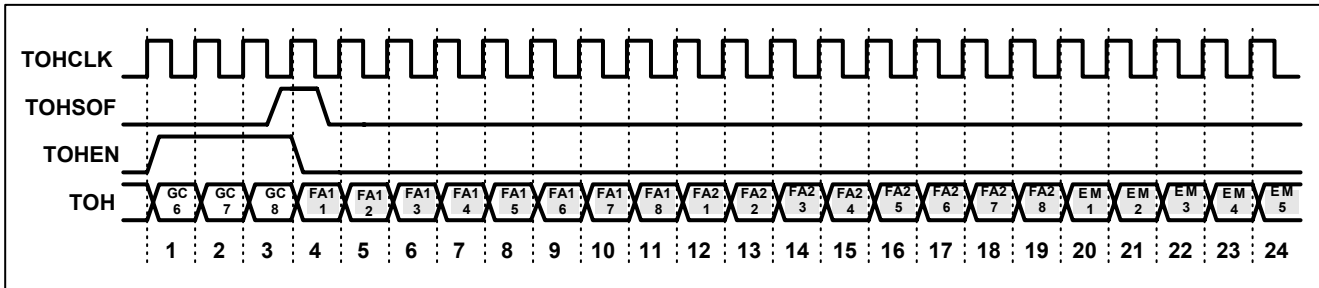

Figure 8-12 shows the relationship between the E3 G.832 transmit overhead port pins.

Figure 8-12. E3 G.832 Framing Transmit Overhead Port Timing



8.3.3 DS3/E3 Serial Data Interface

8.3.3.1 DS3/E3 SCT Mode Transmit Serial Interface Pin Functional Timing

The TSERN pin is used to input DS3 or E3 payload data bits in all framing modes as well as the C-bits, which can be treated as payload, in DS3 M23 and E3 G.751 framing modes. The TDENn signal is used to determine the DS3 or E3 payload bit positions on TSERN. The TDENn signal goes high three clocks before the first bit of a payload sequence is clocked into the TSERN pin and it goes low three clocks before the payload sequence is stopped being clocked in to the TSERN pin. The TSOFOn signal pulses high three clocks before the start of the DS3 or E3 overhead bit position on TSERN. The TSOFIn pin is used to set the DS3 or E3 frame position. When the TSOFIn pin transitions low to high, the first DS3/E3 overhead bit position on TSERN will be forced to align to it

Figure 8-13 to Figure 8-15 show the relationship between the SCT transmit port pins.

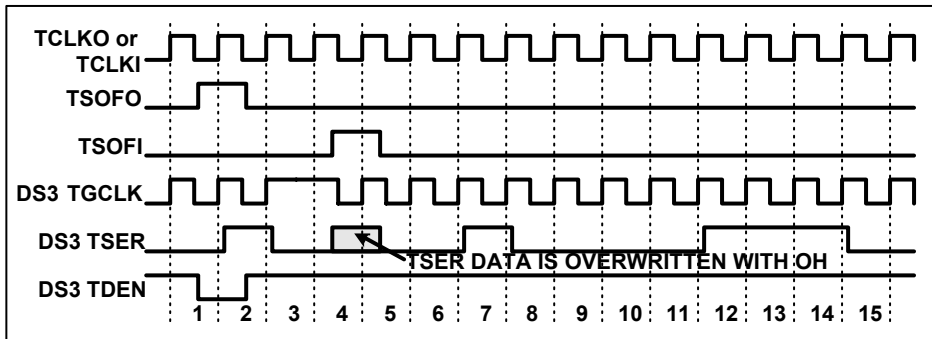
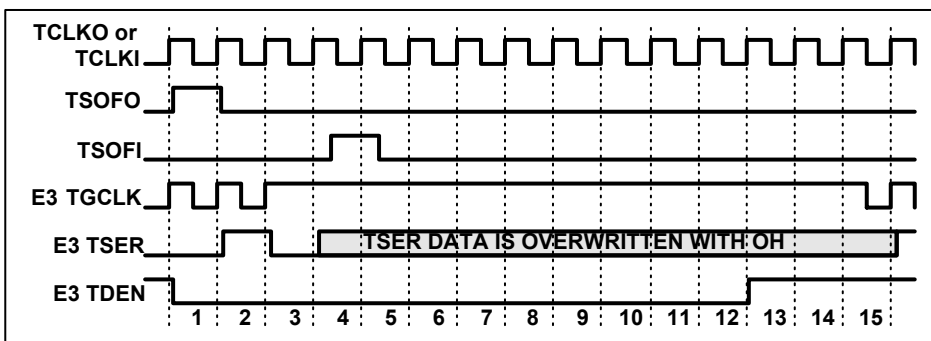
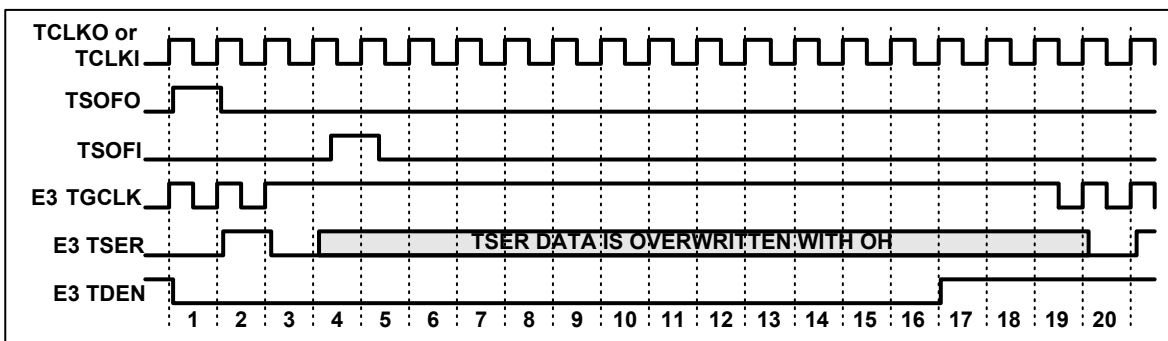
Figure 8-13. DS3 SCT Mode Transmit Serial Interface Pin Timing**Figure 8-14. E3 G.751 SCT Mode Transmit Serial Interface Pin Timing****Figure 8-15. E3 G.832 SCT Mode Transmit Serial Interface Pin Timing**

8.3.3.2 DS3/E3 SCT Mode Receive Serial Interface Pin Functional Timing

The RSERn signal has the DS3 or E3 payload as well as the DS3 or E3 overhead bits. The RDENn signal is used to enable external logic for payload processing and will be high during the DS3 or E3 payload bits and low during the DS3 or E3 overhead bits. The RGCLKn signal can also be used to clock only the DS3 or E3 payload bits into external logic since the clock is stopped during the DS3 or E3 overhead bits. The RSOFO_n signal marks the first overhead bit of the DS3 or E3 frame.

[Figure 8-16](#) to [Figure 8-18](#) show the relationship between the SCT receive port pins.

Figure 8-16. DS3 SCT Mode Receive Serial Interface Pin Timing

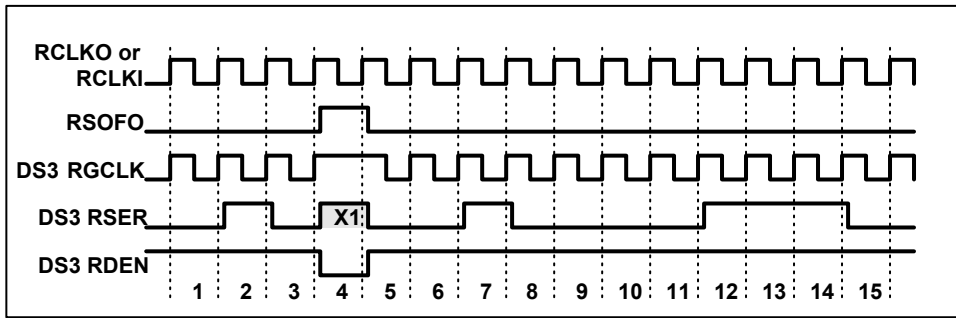

Figure 8-17. E3 G.751 SCT Mode Receive Serial Interface Pin Timing

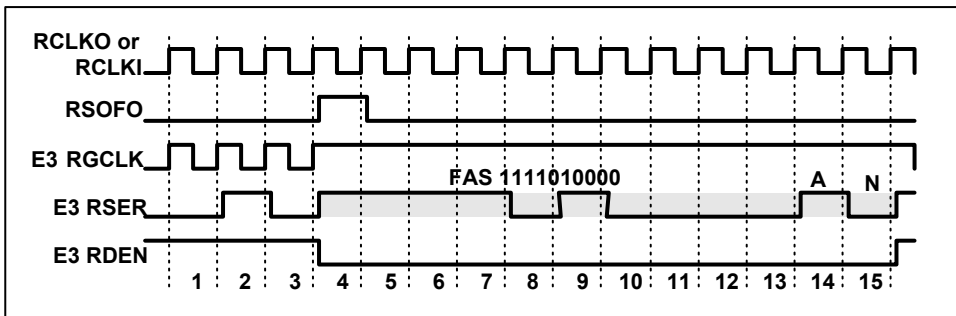
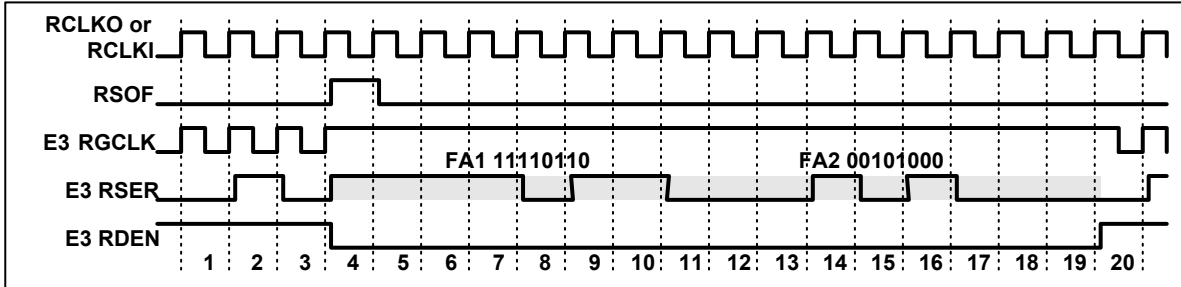

Figure 8-18. E3 G.832 SCT Mode Receive Serial Interface Pin Timing



8.3.4 Microprocessor Interface Functional Timing

Figure 8-19 and Figure 8-21 show examples of a 16-bit databus and an 8-bit databus, respectively. In 16-bit mode, the A[0]/BSWAP signal controls whether or not to byte swap. In 8-bit mode, the A[0]/BSWAP signal is used as the LSB of the address bus (A[0]). The selection of databus size is determined by the WIDTH input signal. See also Section 10.1.1.

Figure 8-19. 16-Bit Mode Write

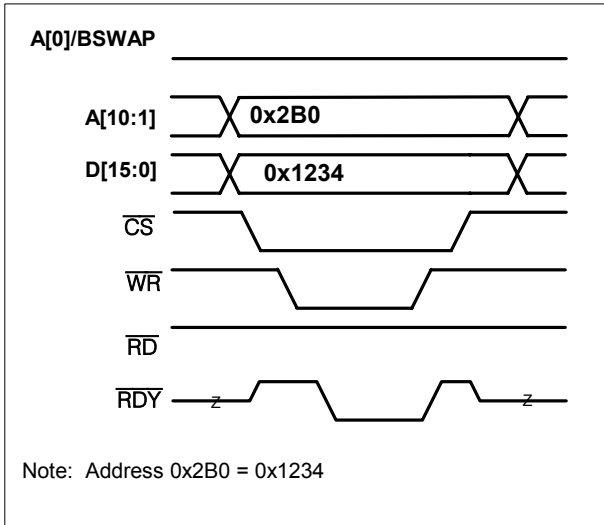

Figure 8-20. 16-Bit Mode Read

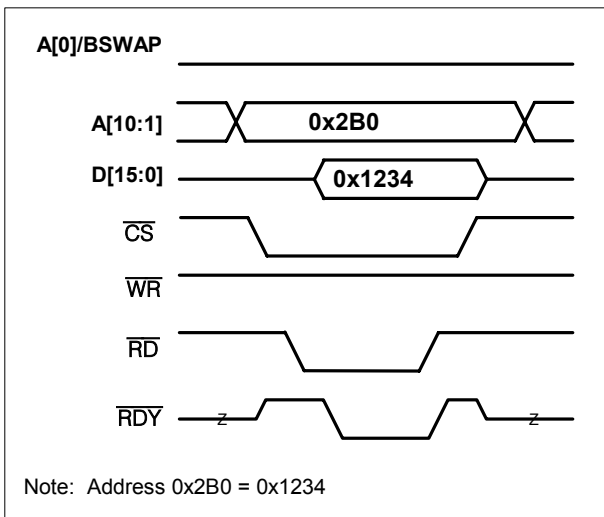
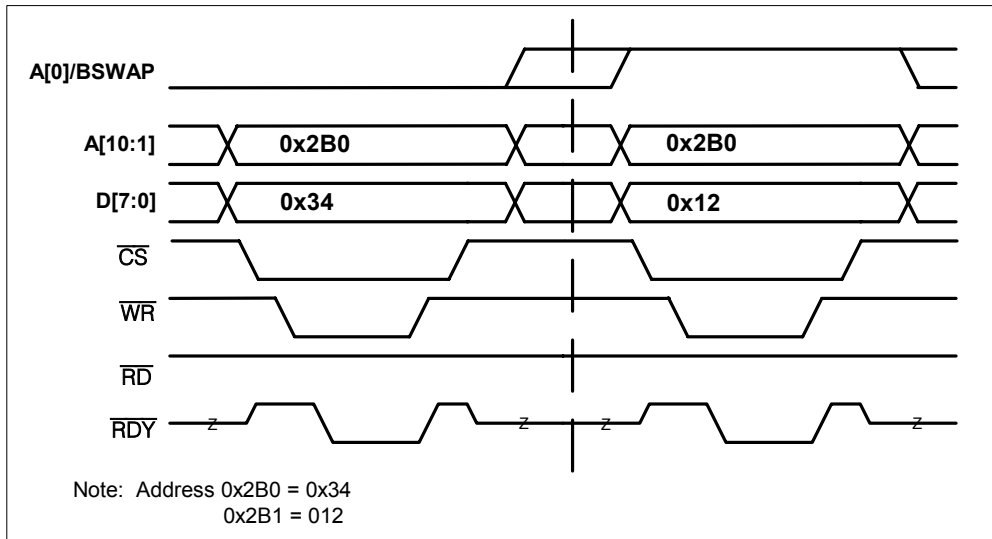
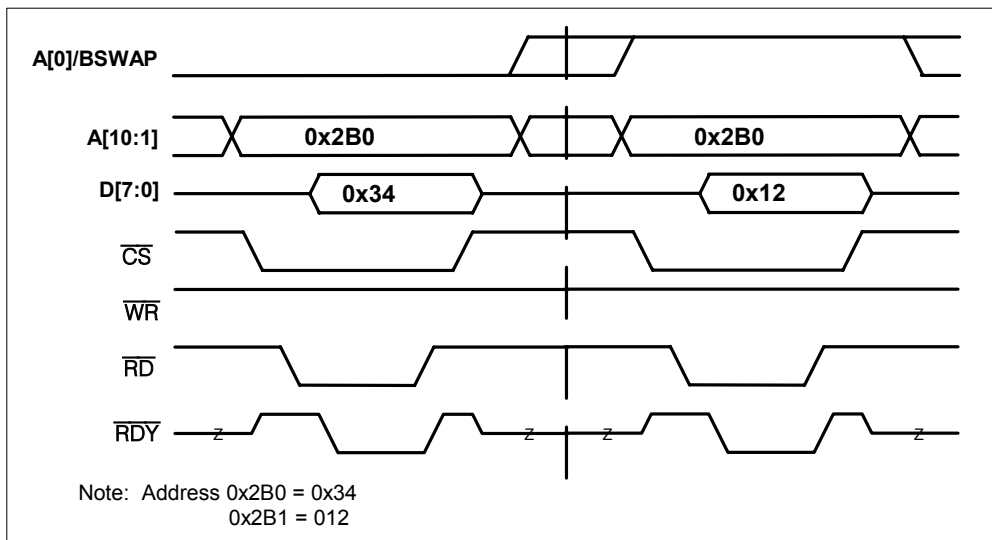
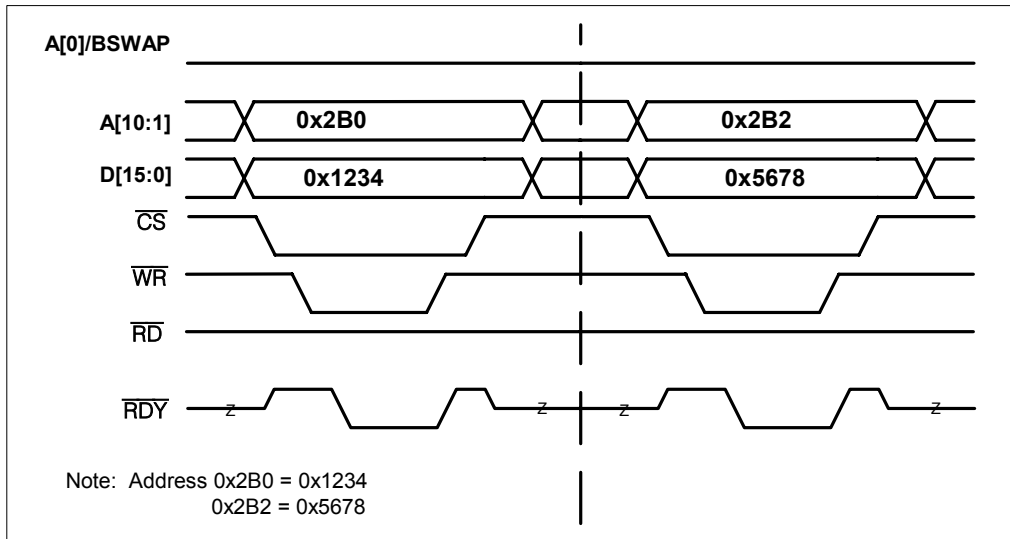
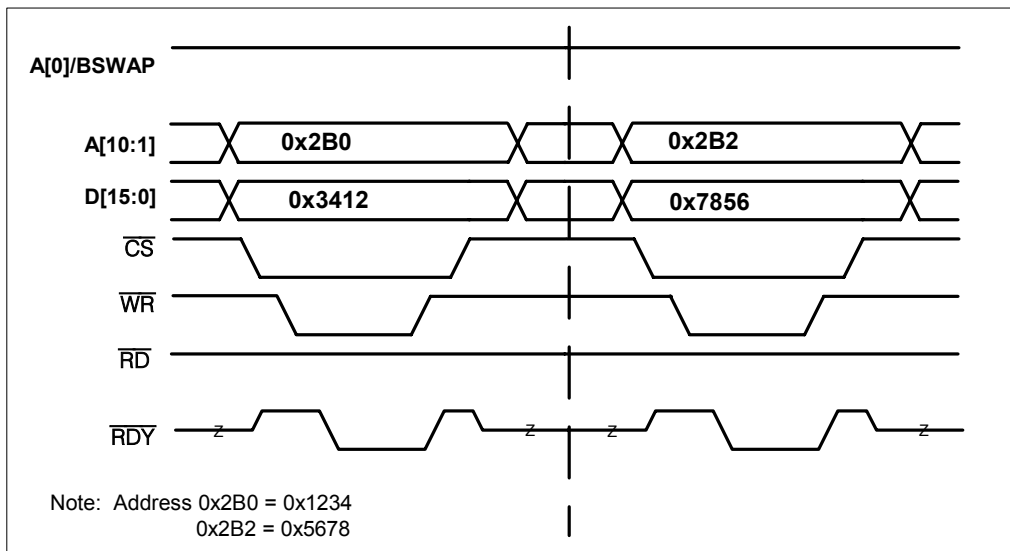

Figure 8-21. 8-Bit Mode Write**Figure 8-22. 8-Bit Mode Read**

[Figure 8-23](#) and [Figure 8-24](#) are examples of databuses without and with byte swapping enabled, respectively. When the A[0]/BSWAP pin is set to 0, byte swapping is disabled, and when one, byte swapping is enabled. This pin should be static and not change while operating. Note: Address bit A[0] is not used in 16-bit mode. See also [Section 10.1.2](#).

Figure 8-23. 16-Bit Mode without Byte Swap**Figure 8-24. 16-Bit Mode with Byte Swap**

Clearing status latched registers on a read or write access is selectable via the [GL_CR1.LSBCRE](#) register bit. Clearing on read clears all bits in the register, while the clear on write clears only those bits which are written with a '1' when the user writes to the status latched register.

To use the Clear on Read method, the user must only read the status latched register. All bits are set to zero after the read. [Figure 8-25](#) shows a read of a status latched register and another read of the same register verifying the register has cleared.

To use the Clear on Write method, the user must write the register with ones in the bit locations that he desires to clear. [Figure 8-26](#) shows a read, a write, and then a subsequent read revealing the results of clearing of the bits that he wrote a '1.' See also Section [10.1.5](#).

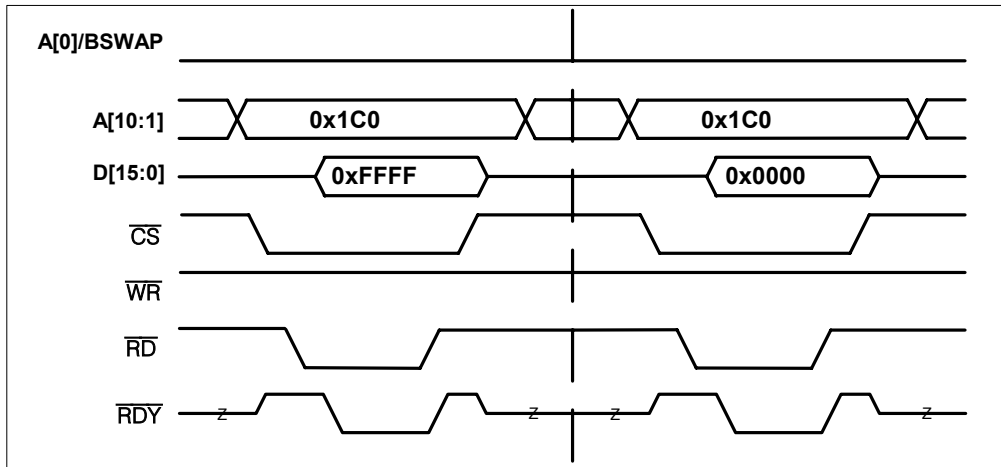
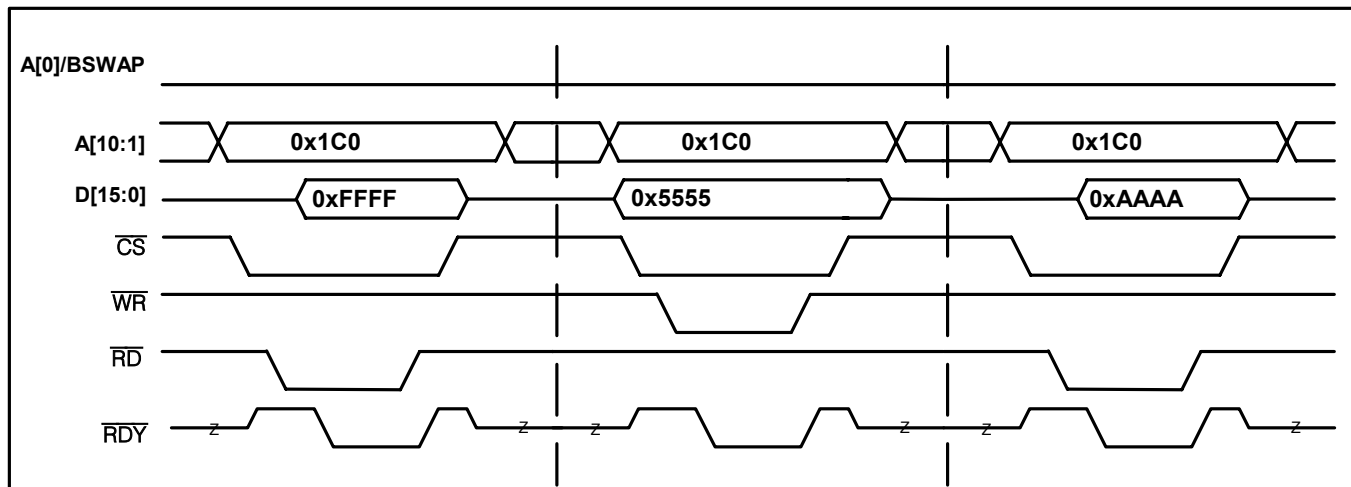
Figure 8-25. Clear Status Latched Register on Read**Figure 8-26. Clear Status Latched Register on Write**

[Figure 8-27](#) and [Figure 8-28](#) show exaggerated views of the Ready Signal to describe the difference in access times to write or read to or from various memory locations on the DS317x device. Some registers will have a faster access time than others will and if needed, the user can implement the RDY signal to maximize efficiency of read and write accesses.

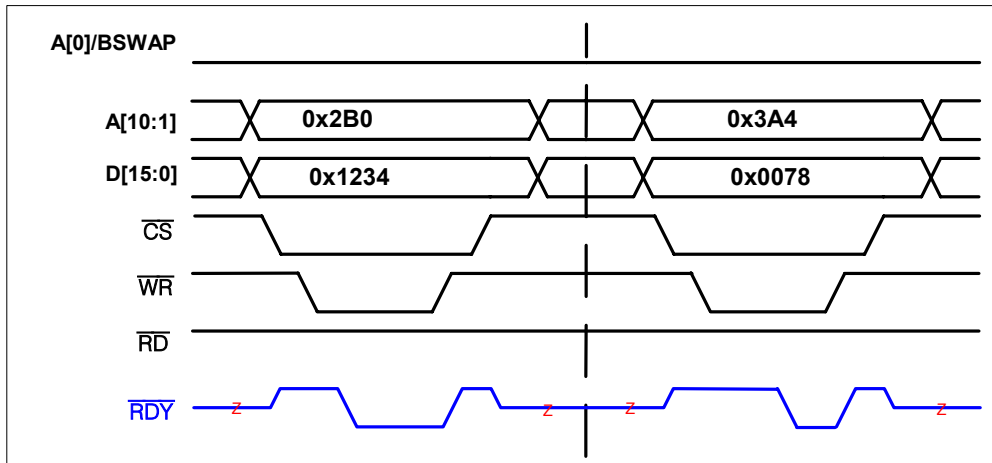
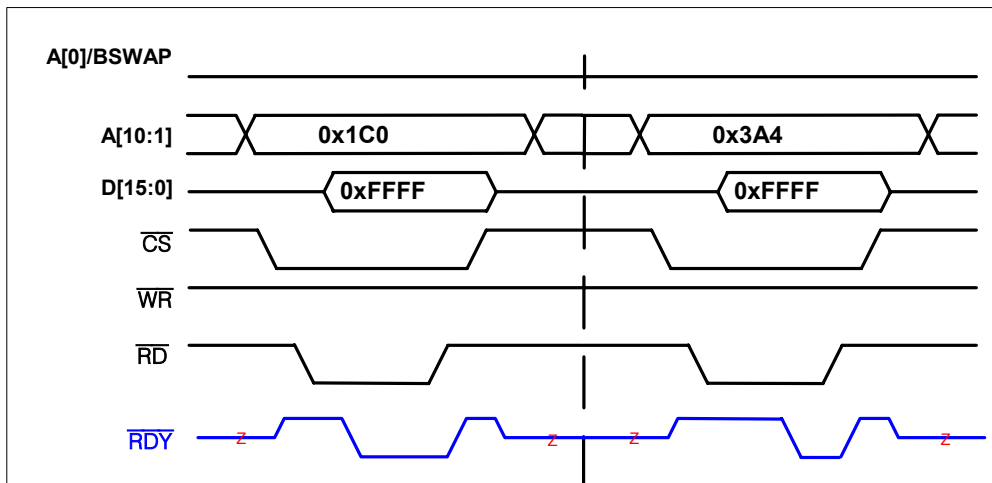
Figure 8-27. RDY Signal Functional Timing Write**Figure 8-28. RDY Signal Functional Timing Read**

See also [Figure 18-7](#) and [Figure 18-8](#).

8.3.5 JTAG Functional Timing

See Section [13.5](#).

9 INITIALIZATION AND CONFIGURATION

STEP 1: Check Device ID Code:

Before any testing can be done, device ID code, which is stored in `GL.IDR`, should be checked against device ID codes shown below to ensure correct device is being used.

Current device ID codes are:

- **DS3171 rev 1.0: 0044h**
- **DS3172 rev 1.0: 0045h**
- **DS3173 rev 1.0: 0046h**
- **DS3174 rev 1.0: 0047h**

STEP 2: Initialize the Device.

Before configuring for operation, make sure the device is in a known condition with all registers set to their default value by initiating a Global Reset (see Section [10.3](#)). A Global Reset can be initiated via the RST pin or by the Global Reset bit (`GL.CR1.RST`). A Port Reset is not necessary since the global reset includes a reset of all ports to their default values.

STEP 3: Clear the Reset.

It is necessary to clear the RST bit to begin normal operation.

After clearing the RST bit, the device is configured for default mode.

Default mode:

Framer: C-bit DS3
LIU: Disabled

STEP 4: Clear the Data Path Resets and the Port Power-Down bit.

The default value of the Data Path Resets is one, which keeps the internal logic in the reset status. The user needs to clear the following bits:

`GL.CR1.RSTD` = 0
`PORT.CR1.RSTD` = 0
`PORT.CR1.PD` = 0

STEP 5: Configure the CLAD

If using the LIU, configure the CLAD (which supplies the clock to the Receive LIU) via the CLAD bits in the [GL.CR2](#) register.

Note: The user must supply a DS3, E3, or STS-1 clock to the CLKA pin.

STEP 6: Select the clock source for the transmitter.

Loop Time (use the receive clock): Set `PORT.CR3.LOOPT` = 1
CLAD Source: Set `PORT.CR3.CLADC` = 0
TCLKI Source: Set `PORT.CR3.CLADC` = 1

If using the CLAD, properly configure the CLAD by setting the CLAD bits in [GL.CR2](#).

STEP 7: Configure the Framing Mode and the Line Mode..

`PORT.CR2.LM[2:0]` = 011 (LIU on, JA in Rx side) or another setting. See [Table 10-26](#)
`PORT.CR2.FM[2:0]` set to correct mode. See [Table 10-25](#).

STEP 8: Disable Payload AIS (downstream AIS) and Line AIS

`PORT.CR1.PAIS[2:0]` = 111
`PORT.CR1.LAIS[1:0]` = 11

STEP 9: Enable each port (for non-LIU modes)

`PORT.CR2.TLEN` = 1

Table 9-1. Configuration of Port Register Settings

Note: The Line Mode has been configured with the LIU enabled and the JA in the receive path (LM[2:0] = 011) for all modes. Only Port 1 registers have been displayed.

Test the DS317x with the following configuration settings.

MODE	PORT.CR1 0x040	PORT.CR2 0x042	PORT.CR3 0x044	PORT.CR4 0x046
DS3 C-Bit SCT	0x7C00	0000 0011 0000 0111	0x0000	0x0000
DS3 M13 SCT	0x7C00	0000 0011 0000 1111	0x0000	0x0000
E3.751 SCT	0x7C00	0000 0011 0001 0111	0x0000	0x0000
E3.823 SCT	0x7C00	0000 0011 0001 111X	0x0000	0x0000

Considerations

For best performance of the CLAD to meet jitter requirements across the temperature range, especially @ -40 C, the following test registers should be set after reset:

Address 0x20B = 0x11

Address 0x20F = 0x11

9.1 Monitoring and Debugging

To determine if the device is receiving a good signal and that the chip is correctly configured for its environment, check the following status registers.

Receive Loss of Lock – [PORT.SR](#).RLOL – The clock recovery circuit of the LIU was unable to recover the clock from the incoming signal. This may indicate that the LIU's master clock does not match the frequency of the incoming signal. Verify that the CLAD is configured to match the clock input on the CLKA, CLKB, and CLKC pins (DS3, E3, STS-1). See [Table 10-11](#).

Loss of Signal – [LINE.RSR](#).LOS – This indicates that the LIU is unable to recover the clock and data because there is no signal on the line, or that the signal is attenuated beyond recovery.

Loss of Frame – [T3.RSR1](#).LOF (or E3751.RSR1 or E3832.RSR1) – This indicates that the framer was unable to synchronize to the incoming data. Verify that the FM bits have been correctly configured for the correct mode of traffic (DS3, E3 G.751, E3 G.832)

Other helpful techniques to utilize in diagnosing a problem include using Line Loopback and Diagnostic Loopback. These features help to isolate and identify the source of the problem. Line Loopback will loop the receive input to the transmit output, eliminating the transmit side input from the equation. Diagnostic Loopback will loop the transmit output before the LIU to the receive framer, eliminating the analog Receive LIU and the receive side analog circuitry.

One other potential problem is the **Line Encoding/Decoding**. The device needs to be configured in the same mode as the far end piece of equipment. If the far end piece of equipment is transmitting and receiving HDB3/B3ZS encoded data, the DS317x also must be configured to do the same. This is controlled by the *LINE.TCR*.TZSD and the *LINE.RCR*.RZSD bits.

10 FUNCTIONAL DESCRIPTION

10.1 Processor Bus Interface

10.1.1 8/16 Bit Bus Widths

The external processor bus can be sized for 8 or 16 bits using the WIDTH pin. When in 8-bit mode (WIDTH=0), the address is composed of all the address bits including A[0], the lower 8 data lines D[7:0] are used and the upper 8 data lines D[15:8] are not used and never driven during a read cycle. When in 16-bit mode (WIDTH=1), the address bus does not include A[0] (the LSB of the address bus is not routed to the chip) and all 16 data lines D[15:0] are used. See [Figure 8-19](#) and [Figure 8-21](#) for functional timing diagrams.

10.1.2 Ready Signal (\overline{RDY})

The \overline{RDY} signal allows the microprocessor to use the minimum bus cycle period for maximum efficiency. When this signal goes low, the \overline{RD} or \overline{WR} cycle can be terminated. See [Figure 8-27](#) for functional timing diagrams.

NOTE: The \overline{RDY} signal will not go active if the user attempts to read or write unused ports or unused registers not assigned to any design blocks. The \overline{RDY} signal will go active if the user writes or reads reserved registers or unused registers within design blocks.

10.1.3 Byte Swap Modes

The processor interface can operate in byte swap mode when the data bus is configured for 16-bit operation. The A[0]/BSWAP pin is used to determine whether byte swapping is enabled. This pin should be static and not change while operating. When the A[0]/BSWAP pin is low the upper register bits REG[15:8] are mapped to the upper external data bus lines D[15:8], and the lower register bits REG[7:0] are mapped to the lower external data bus lines D[7:0]. When the A[0]/BSWAP pin is high the upper register bits REG[15:8] are mapped to the lower external data bus lines D[7:0], and the lower register bits REG[7:0] are mapped to the upper external data bus lines D[15:8]. See [Figure 8-23](#) and [Figure 8-24](#) for functional timing diagrams.

10.1.4 Read-Write / Data Strobe Modes

The processor interface can operate in either read-write strobe mode or data strobe mode. When MODE=0 the read-write strobe mode is enabled and a negative pulse on \overline{RD} performs a read cycle, and a negative pulse on \overline{WR} performs a write cycle. When MODE=1 the data strobe mode is enabled and a negative pulse on \overline{DS} when R/\overline{W} is high performs a read cycle, and a negative pulse on \overline{DS} when R/\overline{W} is low performs a write cycle. The read-write strobe mode is commonly called the “Intel” mode, and the data strobe mode is commonly called the “Motorola” mode.

10.1.5 Clear on Read / Clear on Write Modes

The latched status register bits can be programmed to clear on a read access or clear on a write access. The global control register bit *GL.CR1.LSBCRE* controls the mode that all of the latched registers are cleared. When LSBCRE=0, the latched register bits will be cleared when the register is written to and the write data has the register bits to clear set. When LSBCRE=1, the latched register bits that are set will be cleared when the register is read.

The clear on write mode expects the user to use the following protocol:

1. Read the latched status register
2. Write to the registers with the bits set that need to be cleared.

This protocol is useful when multiple uncoordinated software tasks access the same latched register. Each task should only clear the bits with which it is concerned; the other tasks will clear the bits with which they are concerned.

The clear on read mode is simpler since the bits that were read as being set will be cleared automatically. This method will work well in a software system where multiple tasks do not read the same latched status register. The latched status register bits in clear on read mode are carefully designed not to miss events that occur while a register is being read when the latched bit has not already been set. Refer to [Figure 8-25](#) and [Figure 8-26](#).

10.1.6 Global Write Method

All of the ports can be written to simultaneously using the global write method. This method is enabled by setting the [GL.CR1](#).GWM bit. When the global write method is enabled, a write to a register on any valid port will write to the same register on all valid ports. A valid port is a port that is available in a particular packaged part. For example, port four would not be valid in a DS3173 device. After reset, the global write method is not enabled.

When the GWM bit is set, read data from the port registers is not valid and read data from the global and test registers is valid. The data value read back from a port register should be ignored.

10.1.7 Interrupt and Pin Modes

The interrupt ($\overline{\text{INT}}$) pin is configurable to drive high or float when not active. The [GL.CR1](#).INTM bit controls the pin configuration, when it is set the $\overline{\text{INT}}$ pin will drive high when not active. After reset, the $\overline{\text{INT}}$ pin will be in high impedance mode until an interrupt source is active and enabled to drive the interrupt pin.

10.1.8 Interrupt Structure

The interrupt structure is designed to efficiently guide the user to the source of an enabled interrupt source. The status bits in the global status (*GL.SR*) and global status latched register (*GL.SRL*) are read to determine if the interrupt source is a global event, a global performance monitor update or whether it came from one of the ports. If the interrupt event came from one of the ports then the port status register (*PORT.SR*) and port status register latched (*PORT.SRL*) can be read to determine if the interrupt source is a common port event like the performance monitor update or LIU or whether it came from one of the DS3/E3 Framers, BERT, HDLC, FEAC or Trail Trace status registers. If the interrupt came from one of the DS3/E3 Framers, BERT, HDLC, FEAC or Trail Trace status registers, then one of those registers will need to be read to determine the event that caused the interrupt.

The source of an interrupt can be determined by reading three status registers: the global, port and block status registers.

When a mode is not enabled, then interrupts from that source will not occur. For example, if E3 framing mode is enabled, an interrupt source that is defined in DS3 framing, but not in E3 framing, cannot create a new interrupt. Note that when modes are changed, the latched status bits of the new mode, as well as any other mode, may get set. If the data path reset is set during or after the mode change, the latched status bits will be automatically cleared. If the data path reset is not used to clear the latched status bits, then the registers must be cleared by reading or writing to them based on the register clear method selected.

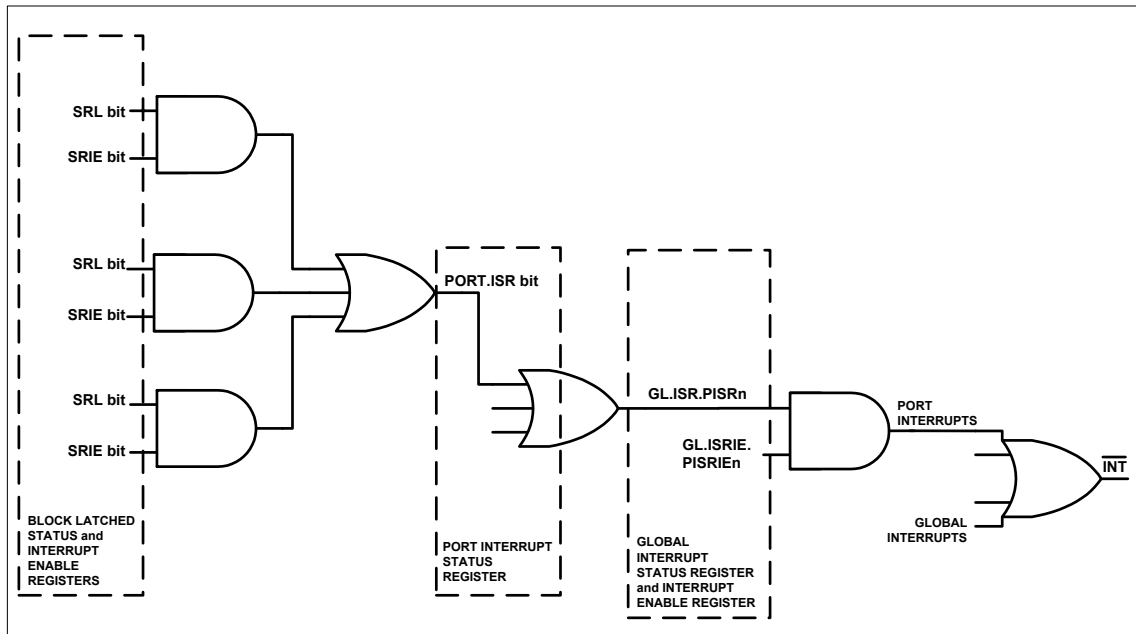
Figure 10-1. Interrupt Structure

[Figure 10-1](#) not only tells the user how to determine which event caused the interrupt, it also tells the user how to enable a particular interrupt. Each block has a Status Register Interrupt Enable register that must be set in order to enable an interrupt. The next step is to unmask the interrupt at the port level, on a per port basis. This is controlled in the Global Interrupt Status Register Interrupt Enable register ([GL.ISRIE](#)). Now the device is ready to drive the INT pin low when a particular status bit gets set.

For example, in order to enable DS3 Out of Frame interrupts on Port 2, the following registers would need to be written:

Register bit	Address	Value Written	Note
T3.RSRIE1.OOFIE	0x2BC	0x0002	Unmask OOF interrupt on Port 2
GL.ISRIE.PISR2	0x010	0x0020	Unmask Port 2 interrupts

The following status registers bits will be set upon reception of OOF on Port 2:

Register bit	Address	Value Read	Note
T3.RSRL1.OOFL	0x2B8	0x0002	DS3 Out of Frame on Port 2
PORT.ISR.FMSR	0x250	0x0001	Framer Block Interrupt Active, Port 2
GL.ISR.PISR2	0x010	0x0020	Port 2 Interrupt Active

10.2 Clocks

10.2.1 Line Clock Modes

10.2.1.1 Loop Timing Enabled

When loop timing is enabled ([PORT.CR3.LOOPT](#)), the transmit clock source is the same as the receive clock source. The TCLKIn pins are not used as a clock source. Because loop timing is enabled, the loopback functions (LLB, PLB and DLB) do not cause the clock sources to switch when they are activated. The transmit and receive

signal pins can be timed to a single clock reference without concern about having the clock source change during loopbacks.

10.2.1.1.1 LIU Enabled, Loop Timing Enabled

In this mode, the receive LIU sources the clock for both the receive and transmit logic. The RCLKOn, TCLKOn and TLCLKn clock output pins will be the same. The transmit or receive line payload signal pins can be timed to any of these clock. The use of the RCLKOn pin as the timing source is suggested. If RCLKOn is used as the timing source, be sure to set [PORT.CR3.RFTS](#) = 0 for output timing.

10.2.1.1.2 LIU Disabled, Loop Timing Enabled

In this mode, the RLCLKn pins are the source of the clock for both the receive and transmit logic. The RCLKOn, TCLKOn and TLCLKn clock output pins will both be the same as the RLCLKn clock. The transmit or receive line payload signals can be timed to any of these clock pins. The use of the RLCLKn pin as the timing source is suggested. If RLCLKn is used as the timing source, be sure to set [PORT.CR3.RFTS](#) = 1 for input timing.

10.2.1.2 Loop Timing Disabled

When loop timing is disabled, the transmit clock source can be different than the receive clock source. The loopback functions, LLB, PLB and DLB, will cause the clock sources to switch when they are activated. Care must be taken when selecting the clock reference for the transmit and receive signals.

The most versatile clocking option has the receive line interface signals timed to RLCLKn, the transmit line interface signals timed to TLCLKn, the receive framer signals timed to RCLKOn, and the transmit framer signals timed to TCLKOn. This clocking arrangement works in all modes.

When LLB is enabled, the clock on the TLCLKn pins will switch to the clock from the RLCLKn pins or RX LIU. It is recommended that the transmit line interface signals be timed to the TLCLKn pins. If TLCLKn is used as the timing source, be sure to set [PORT.CR3.TLTS](#) = 0 for output timing.

When PLB is enabled, the TCLKIn pin will not be used and the internal transmit clock is switched to the internal receive clock. The clock on the TCLKOn pins will switch to the clock from the RLCLKn pins or RX LIU. The framer input signals will be ignored while PLB is enabled. It is recommended that the transmit line interface signals be timed to the TCLKOn pins.

When DLB is enabled, the internal receive clock is switched to the internal transmit clock which is sourced from the TCLKIn pins or one of the CLAD clocks, and the clock on the RLCLKn pins or from the RX LIU will not be used. The clock on the RCLKOn pins will switch to the clock on the TCLKIn pins or one of the CLAD clocks. The receive line signals from the RX LIU or line interface pins will be ignored. It is recommended that the receive framer pins be timed to the RCLKOn pins. If TCLKOn is used as the timing source, be sure to set [PORT.CR3.TFTS](#) = 0 for output timing.

When both DLB and LLB are enabled, the TLCLKn clock pins are connected to either the RX LIU recovered clock or the RLCLKn clock pins, and the RCLKOn clock pins will be connected to the TCLKIn clock pins or one of the CLAD clocks. It is recommended that the transmit line signals be timed to the TLCLKn pins, the receive line interface signals be timed to the RLCLKn pins, the receive framer signals be timed to the RCLKOn pins, and the transmit framer signals be timed to the TCLKOn pins.

10.2.1.2.1 LIU Enabled - CLAD Timing Disabled – no LB

In this mode, the receive LIU sources the clock for the receive logic and the TCLKIn pins source the clock for the transmit logic.

10.2.1.2.2 LIU Enabled - CLAD Timing Enabled – no LB

In this mode, the receive LIU sources the clock for the receive logic and one of the CLAD clocks sources the clock for the transmit logic.

10.2.1.2.3 LIU Disabled - CLAD Timing Disabled – no LB

In this mode, the RLCLKn pins source the clock for the receive logic and the TCLKIn pins source the clock for the transmit logic.

10.2.1.2.4 LIU Disabled - CLAD Timing Enabled – no LB

In this mode, the RLCLKn pins source the clock for the receive logic and one of the CLAD clocks sources the clock for the transmit logic.

10.2.2 Sources of Clock Output Pin Signals

The clock output pins can be sourced from many clock sources. The clock sources are the transmit input clocks pins (TCLKIn), the receive clock input pins (RLCLKn), the recovered clock in the receive LIUs, and the clock signals in the clock rate adapter circuit (CLAD). The default clock source for the receive logic is the RLCLKn pin if the LIU is disabled; otherwise the default clock is sourced from the RX LIU clock when the RX LIU is enabled. The default clock source for the transmit logic is the CLAD clocks.

The LIU is enabled based on the line mode bits(LM[2:0]) (See [Table 10-26](#)). The bits LM[2:0], LBM[2:0], LOOPT and CLADC are located in the port configuration registers. LIUEN is not a register bit; it is a variable based on the line mode bits. [Table 10-1](#) decodes the LM bits for LIUEN selection.

Table 10-1. LIU Enable Table

LM[2:0]	LIUEN	LIU Status
000	0	Disabled
001	1	Enabled
010	1	Enabled
011	1	Enabled
1XX	0	Disabled

[Table 10-2](#) identifies the framer clock source and the line clock source depending on the mode that the device is configured. Putting the device in loopback will typically mux in a different clock than the normal clock source.

Table 10-2. All Possible Clock Sources Based on Mode and Loopback

MODE	LOOPBACK	Rx FRAMER CLOCK SOURCE	Tx FRAMER CLOCK SOURCE	Tx LINE CLOCK SOURCE
Loop Timed	Any	RLCLKn or RXLIU	Same as Rx	Same as Rx
Normal	None	RLCLKn or RXLIU	TCLKIn or CLAD	Same as Tx
Normal	LLB	RLCLKn or RXLIU	TCLKIn or CLAD	Same as Rx
Normal	PLB	RLCLKn or RXLIU	Same as Rx	Same as Rx
Normal	DLB	Same as Tx	TCLKIn or CLAD	Same as Tx
Normal	LLB and DLB	Same as Tx	TCLKIn or CLAD	RLCLKn or RXLIUn

[Table 10-3](#) identifies the source of the output signal TLCLKn based on certain variables and register bits.

Table 10-3. Source Selection of TLCLK Clock Signal

Signal	LOOP PORT. CR3	LBM[2:0] (PORT.CR4)	LLB or PLB	LIUEN	CLADC (PORT. CR3)	Source
TLCLK _n	1	XXX	NA	1	X	RX LIU
	1	XXX	NA	0	X	RLCLK _n
	0	010	LLB	1	X	RX LIU
	0	110	LLB	1	X	RX LIU
	0	010	LLB	0	X	RLCLK _n
	0	110	LLB	0	X	RLCLK _n
	0	011	PLB	1	X	RX LIU
	0	011	PLB	0	X	RLCLK _n
	0	000	NO	X	0	CLAD
	0	001	NO	X	0	CLAD
	0	100	NO	X	0	CLAD
	0	10X	NO	X	0	CLAD
	0	111	NO	X	0	CLAD
	0	000	NO	X	1	TCLK _{In}
	0	001	NO	X	1	TCLK _{In}
	0	100	NO	X	1	TCLK _{In}
	0	10X	NO	X	1	TCLK _{In}
	0	111	NO	X	1	TCLK _{In}

Figure 10-2 shows the source of the TCLK_{On} signals.

Figure 10-2. Internal TX Clock

Table 10-4 identifies the source of the output signal TCLK_{On} based on certain variables and register bits.

Table 10-4. Source Selection of TCLKOn (internal TX clock)

Signal	LOOPT PORT.CR3	LBM[2:0] (PORT.CR4)	LIUEN	CLADC (PORT. CR3)	Source
TCLKOn	1	XXX	1	X	RX LIU
	1	XXX	0	X	RLCLKn
	0	PLB (011)	1	X	RX LIU
	0	PLB (011)	0	X	RLCLKn
	0	PLB disabled	X	0	CLAD
	0	PLB disabled	X	1	TCLKIn

[Figure 10-3](#) shows the source of the RCLKOn signals.

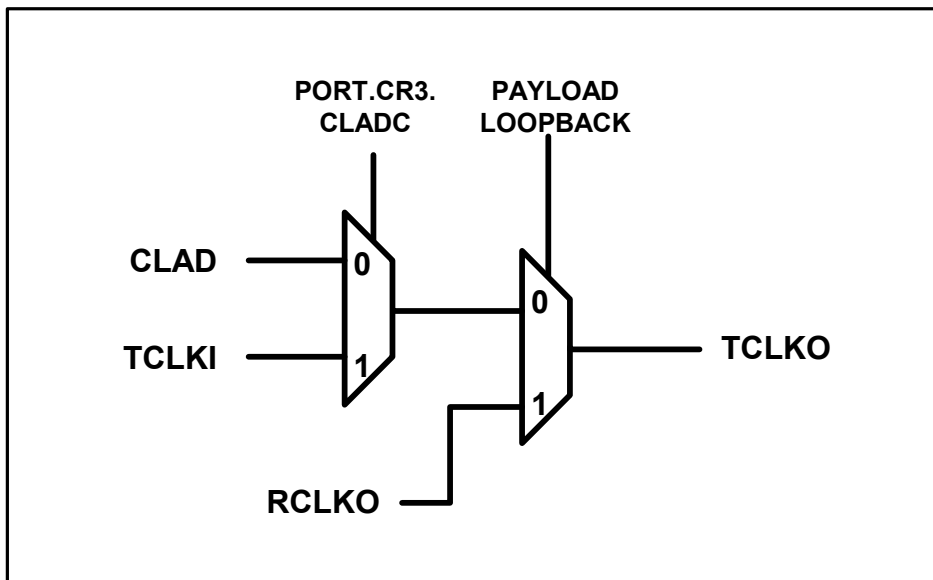
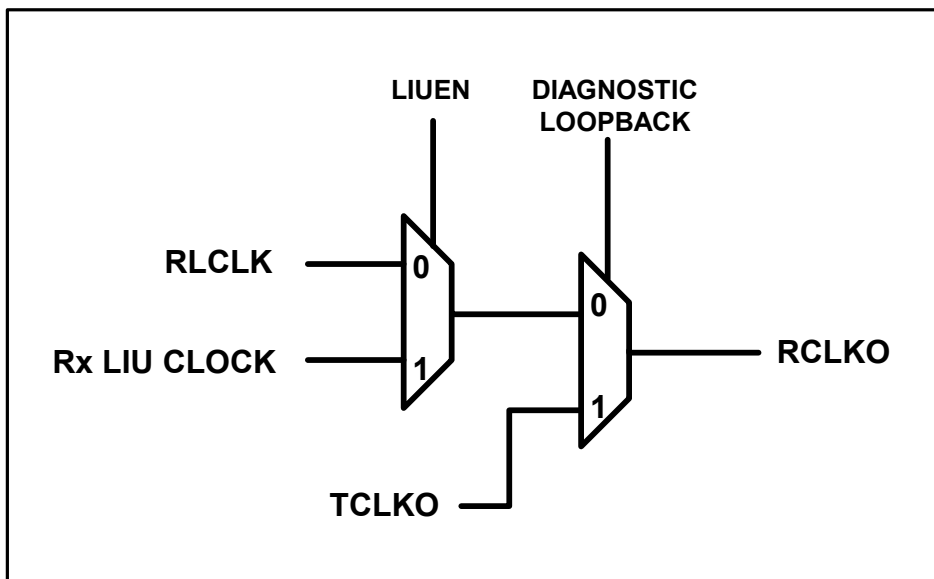
Figure 10-3. Internal RX Clock

[Table 10-5](#) identifies the source of the output signal RCLKOn based on certain variables and register bits.

Table 10-5. Source Selection of RCLKO Clock Signal (internal RX clock)

Signal	LOOPT PORT.CR3	LBM[2:0] (PORT.CR4)	LIUEN	CLADC (PORT. CR3)	Source
RCLKOn	1	XXX	1	X	RX LIU
	1	XXX	0	X	RLCLKn
	0	DLB disabled	1	X	RX LIU
	0	DLB disabled & ALB disabled	0	X	RLCLKn
	0	DLB (1XX)	X	0	CLAD
	0	DLB (1XX) or ALB (001)	0	1	TCLKIn
	0	DLB (1XX)	1	1	TCLKIn

10.2.3 Line IO Pin Timing Source Selection

The line IO pins can use any input clock pin (RLCLKn or TCLKIn) or output clock pin (TLCLKn, RCLKOn, or TCLKOn) for its clock pin and meet the AC timing specifications as long as the clock signal is valid for the mode the part is in. The clock select bit for the transmit line IO signal group [PORT.CR3.TLTS](#) selects the correct input or output clock timing.

10.2.3.1 Transmit Line Interface Pins Timing Source Selection

(TPOSn/TDATn, TNEGn)

The transmit line interface signal pin group has the same functional timing clock source as the TLCLKn pin described in [Table 10-3](#). Other clock pins can be used for the external timing. The TLCLKn transmit line clock output pin is always a valid output clock for external logic to use for these signals when [PORT.CR3.TLTS](#)=0.

The transmit line timing select bit (TLTS) is used to select input or output clock pin timing. When TLTS=0, output clock timing is selected. When TLTS=1, input clock timing is selected. If TLTS is set for input clock timing and an output clock pin is used, or if TLTS is set for output clock timing and an input clock pin is used, then the setup, hold and delay timings, as specified in [Section 18.1](#) will not be valid. There are some combinations of TLTS=1 and other modes in which there is no input clock pin available for external timing since the clock source is derived internally from the RX LIU or the CLAD.

Table 10-6. Transmit Line Interface Signal Pin Valid Timing Source Select

LOOPT	LBM[2:0]	LIUEN	CLADC	TLTS	Valid Timing to These Clock Pins
1	XXX	X	X	0	TLCLKn, TCLKOn, RCLKOn
1	XXX	0	X	1	RLCLKn
1	XXX	1	X	1	No valid timing to any input clock pin
0	DLB (100)	X	X	0	TLCLKn, TCLKOn, RCLKOn
0	LLB (010) or PLB (011)	X	X	0	TLCLKn, RCLKOn
0	DLB&LLB (110)	X	X	0	TLCLKn
0	not DLB (100), not LLB (010), not PLB (011) and not LLB&DLB (110)	X	X	0	TLCLKn, TCLKOn (default)
0	not LLB (010) and not PLB (011) and not LLB&DLB (110)	X	0	1	No valid timing to any input clock pin
0	not LLB (010) and not PLB (011) and not LLB&DLB (110)	X	1	1	TCLKIn
0	LLB (010) or PLB (011) or DLB&LLB (110)	0	X	1	RLCLKn
0	LLB (010) or PLB (011) or DLB&LLB (110)	1	X	1	No valid timing to any input clock pin

10.2.3.2 Transmit Framer Pin Timing Source Selection

(TSERn, TSOFln, TSOFOOn/TDENn)

The transmit framer signal pin group has the same functional timing clock source as the TCLKO pin described in [Table 10-4](#). Other clock pins can be used for the external timing. The TCLKO transmit clock output pin is always a valid output clock for external logic to use for these signals when TFTS=0.

The transmit framer select bit (TFTS) is used to select input or output clock pin timing. When TFTS=0, output clock timing is selected. When TFTS=1, input clock timing is selected. If TFTS is set for input clock timing and an output clock pin is used, or If TFTS is set for output clock timing and an input clock pin is used, then the setup, hold and delay timings, as specified in [Section 18.1](#) will not be valid. There are some combinations of TFTS=1 and other modes in which there is no input clock pin available for external timing since the clock source is derived internally from the RX LIU or the CLAD.

Table 10-7. Transmit Framer Pin Signal Timing Source Select

LOOP	LBM[2:0]	LIUEN	CLADC	TFTS	Valid Timing to These Clock Pins
1	XXX	X	X	0	TCLKOn, TLCLKn, RCLKOn
1	XXX	0	X	1	RLCLKn
1	XXX	1	X	1	No valid timing to any input clock pin
0	PLB (011) or DLB (100) or ALB(001)	0	X	0	TCLKOn, TLCLKn, RCLKOn
0	PLB (011) or DLB (100)	1	X	0	TCLKOn, TLCLKn, RCLKOn
0	DLB&LLB (110)	X	X	0	TCLKOn, RCLKOn
0	LLB (010)	X	X	0	TCLKOn
0	not LLB, DLB or PLB (00X)	X	X	0	TCLKOn, TLCLKn
0	not PLB (011)	X	0	1	No valid timing to any input clock pin
0	not PLB (011)	X	1	1	TCLKIn
0	PLB (011)	0	X	1	RLCLKn
0	PLB (011)	1	X	1	No valid timing to any input clock pin

10.2.3.3 Receive Line Interface Pin Timing Source Selection

(RPOSn/RDATn, RNEGn/RLCVn)

The receive line interface signal pin group must clocked in with the RLCLK clock input pin. When the LIU is enabled, the receive line interface pins are not used so there is no valid clock reference.

Table 10-8. Receive Line Interface Pin Signal Timing Source Select

LOOP	LBM[2:0]	LIUEN	CLADC	Valid Timing to These Clock Pins
X	XXX	0	X	RLCLKn
X	XXX	1	X	No valid timing to any clock pin

10.2.3.4 Receiver Framer Pin Timing Source Selection

(RSERn, RSOFOn/RDENn)

The receive framer signal pin group has the same functional timing clock source as the RCLKOn pin described in [Table 10-5](#).

Other clock pins can be used for the external timing. The RCLKOn receive clock output pin is always a valid output clock for external logic to use for these signals when [PORT.CR3](#).RFTS=0.

The receive framer timing select bit (RFTS) is used to select input or output clock pin timing. When RFTS=0, output clock timing is selected. When RFTS=1, input clock timing is selected. If RFTS is set for input clock timing and an output clock pin is used, or If RFTS is set for output clock timing and an input clock pin is used, then the setup, hold and delay timings, as specified in [Section 18.1](#) will not be valid. There are some combinations of RFTS=1 and other modes in which there is no input clock pin available for external timing since the clock source is derived internally from the RX LIU or the CLAD.

Table 10-9. Receive Framer Pin Signal Timing Source Select

LOOP	LBM[2:0]	LIUEN	CLADC	RFTS	Valid Timing to These Clock Pins
1	XXX	X	X	0	RCLKOn, TLCLKn, TCLKOn
1	XXX	0	X	1	RLCLKn
1	XXX	1	X	1	No valid timing to any input clock pin
0	PLB (011) or DLB (100) or ALB(001)	0	X	0	RCLKOn, TLCLKn, TCLKOn
0	PLB (011) or DLB (100)	1	X	0	RCLKOn, TLCLKn, TCLKOn
0	DLB&LLB (110)	X	X	0	RCLKOn, TCLKOn
0	LLB (010)	X	X	0	RCLKOn, TLCLKn
0	not LLB, DLB or PLB (00X)	X	X	0	RCLKOn
0	DLB (100) or LLB&DLB(110)	X	0	1	No valid timing to any input clock pin
0	DLB (100) or LLB&DLB(110)	X	1	1	TCLKIn
0	not DLB (100) and not LLB&DLB(110)	0	X	1	RLCLKn
0	not DLB (100) and not LLB&DLB(110)	1	X	1	No valid timing to any input clock pin

10.2.4 Clock Structures On Signal IO Pins

The signals on the input pins (TSOFIn, TSERn) can be used with any of the clock pins for setup/hold timing on clock input and output pins. There will be a flop at each input whose clock is connected to the signal from the input or output clock source pins with as little delay as possible from the signal on the clock IO pins. This means using the input clock signal before the delays of the internal clock tree to clock the input signals, and using the output clock signals used to drive the output clock pins to clock the input signals.

The signals on the output pins (TPOSn/TDATn, TNEGn, TSOFOOn/TDENn, RSERn, RSOFOOn/RDENn) can be with any of the clock sources for delay timing. There will be a flop at each output whose clock is connected to the signal from the input or output clock source pins with as little delay as possible from the signal on the clock IO pins. This means using the input clock signal before the delays of the internal clock tree to clock the input signals, and using the output clock signals used to drive the output clock pins to clock the input signals.

Figure 10-4. Example IO Pin Clock Muxing

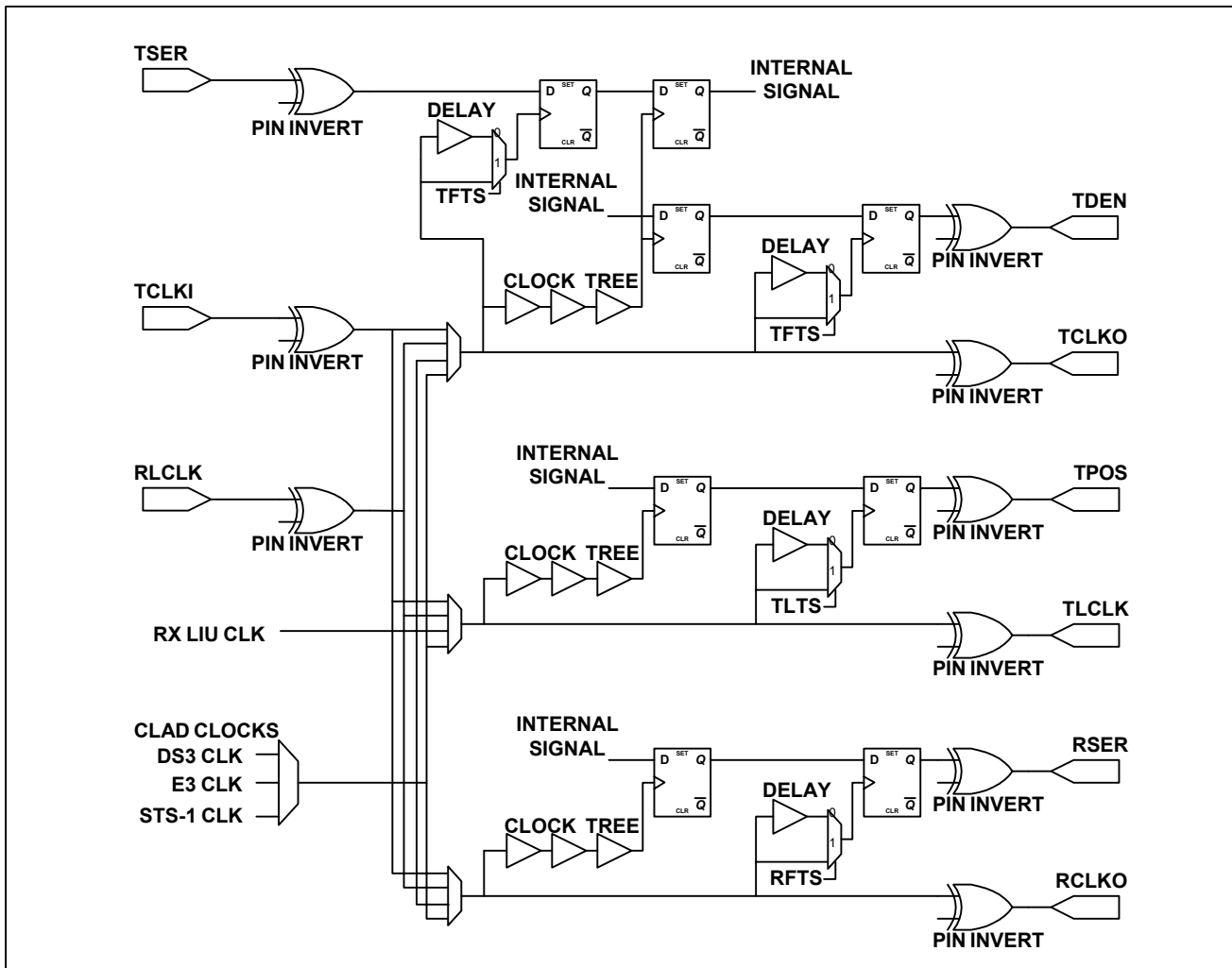

10.2.5 Gapped Clocks

The transmit and receive output clocks can be gapped in certain configurations. See [Table 10-22](#) and [Table 10-24](#) for the configuration settings. The gapped clocks are active during DS3 or E3 framed payload bits overhead bits depending on which mode the device is configured for.

In the internal DS3 or E3 frame modes, the transmit gapped clock is created by the logical OR of the TCLKOn and TDENn signals creating a positive or negative clock edge for each payload bit, the receive gapped clock is created by the logical OR of the RCLKOn and RDENn signals.

When the output clock is disabled, the gapped output signal is high during clock periods if the pin is not inverted, otherwise it will be low.

The gapped clocks are very useful when the data being clocked does not need to be aligned with any frame structure. The data is simply clocked one bit at a time as a continuous data stream.

10.3 Reset and Power-Down

The device can be reset at a global level via the [GL.CR1](#).RST bit or the $\overline{\text{RST}}$ pin and at the port level via the [PORT.CR1](#).RST bit and each port can be explicitly powered down via the [PORT.CR1](#).PD bit. The JTAG logic is reset using the power on reset signal from one of the LIUs as well as from the $\overline{\text{JTRST}}$ pin.

The external $\overline{\text{RST}}$ pin and the global reset bit in the global configuration register ([GL.CR1.RST](#)) are combined to create an internal global reset signal. The global reset signal resets all the status and control registers on the chip, except the [GL.CR1.RST](#) bit, to their default values and resets all the other flops in the global logic and ports to their reset values. The processor bus output signals are also forced to be HIZ when the $\overline{\text{RST}}$ pin is active (low). The global reset bit ([GL.CR1.RST](#)) stays set after a one is written to it, but is reset to zero when the external $\overline{\text{RST}}$ pin is active or when a zero is written to it.

At the port level, the global reset signal combines with the port-reset bit in the port control register ([PORT.CR1.RST](#)) to create a port-reset signal. The port reset signal resets all the status and control registers on the port to their default values and resets all the other flops, except [PORT.CR1.RST](#), to their reset values. The port reset bit ([PORT.CR1.RST](#)) stays set after a one is written to it, but is reset to zero when the global reset signal is active or when a zero is written to it.

The data path reset function is a little different from the “general” reset function. The data path reset signal does not reset the control register bits, but it does reset all of the status registers, counters and flops, the “general” reset signal resets everything including the control register bits, excluding the reset bit. All clocks are functional, being controlled by configuration bits, while data path reset is active. The LIU and CLAD circuits will be operating normally during data path reset, which allows the internal phase locked loops to settle as quickly as possible. The LIU will be sending all zeros (LOS) since data path reset will be forcing the transmit TPOS_n and TNEG_n to logic zero. (NOTE: The BERT data path and control registers are reset when the global data path reset or the port data path reset or the port power-down signal is active.)

The global data path reset bit ([GL.CR1.RSTDP](#)) gets set to one when the global reset signal is active. The port data path reset bit ([PORT.CR1.RSTDP](#)) and the port power-down bit ([PORT.CR1.PD](#)) bit get set to one when the global reset signal is active or the port reset signal is active. These control bits will be cleared when a zero is written to them if the global reset signal or the port-reset signal is not active. The global data path reset signal is active when the global data path reset bit is set. The port data path reset signal is active when either the global data path reset bit or the port data path reset bit is set. The port power-down signal is active when the port power-down bit is set.

Figure 10-5. Reset Sources

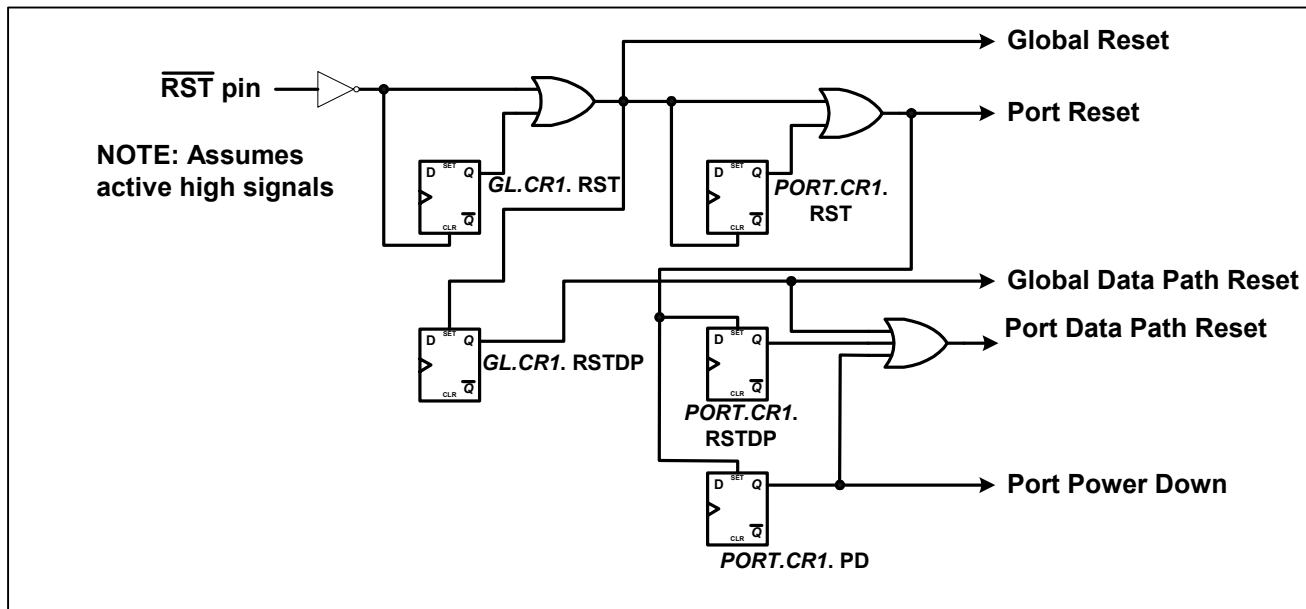

Table 10-10. Reset and Power-Down Sources

Register bit states - F0: Forced to 0, F1: Forced to 1, 0: Set to 0, 1: Set to 1, X: Don't care
 Forced: Internally controlled
 Set: User controlled

PIN	REGISTER BITS					INTERNAL SIGNALS				
	$\overline{\text{RST}}$	G:RST	G:RSTDP	P:RST	P:RSTDP	P:PD	Global reset	Global dp reset	Port reset	Port dp reset
0	F0	F1	F0	F1	F1	1	1	1	1	1
1	1	F1	F0	F1	F1	1	1	1	1	1
1	0	1	1	F1	F1	0	1	1	1	1
1	0	1	0	X	1	0	1	0	1	1
1	0	1	0	X	0	0	1	0	1	0
1	0	0	1	F1	F1	0	0	1	1	1
1	0	0	0	1	1	0	0	0	1	1
1	0	0	0	1	0	0	0	0	1	0
1	0	0	0	0	1	0	0	0	1	1
1	0	0	0	0	0	0	0	0	0	0

The reset signals in the device are asynchronous so they do not require a clock to put the logic into the reset state. Clock signals may be needed to make the logic come out of the reset state.

The power-down function disables the appropriate clocks to cause the logic to generate a minimum of power. It also puts the LIU circuits into the power-down mode. The 8KREF and ONESEC circuits can be powered down by disabling the 8KREF source. The CLAD can also be powered down by disabling it.

After a global reset, all of the control and status registers in all ports are set to their default values and all the other flops are reset to their reset values. The global register [GL.CR1.RSTDP](#), and the port register [PORT.CR1.RSTDP](#) and [PORT.CR1.PD](#) bits in all ports, are set after the global reset. A valid initialization sequence would be to clear the [PORT.CR1.PD](#) bits in the ports that are to be active, write to all of the configuration registers to set them in the desired modes, then clear the [GL.CR1.RSTDP](#) and [PORT.CR1.RSTDP](#) bits. This would cause the logic in the ports to start up in a repeatable sequence. The device can also be initialized by clearing the [GL.CR1.RSTDP](#), [PORT.CR1.RSTDP](#) and [PORT.CR1.PD](#) then writing to all of the configuration registers to set them in the desired modes, and clearing all of the latched status bits. The second initialization scheme could cause the device to temporarily go into modes of operation that were not requested, but will quickly go into the requested modes of operation.

Some of the IO pins are put in a known state at reset. The transmit LIU outputs TXPn and TXNn are quiet and will not drive positive or negative pulses. The global IO pins (GPIO[7:0]) are set as inputs at global reset. The port output pins (TLCLKn, TPOSn/TDATn, TNEGn, TOHCLKn, TOHSOFn, TSOFOOn/TDENn, TCLKOn/TGCLKn, ROHn, ROHCLKn, ROHSOFn, RSErn, RSOFOn/RDENn, RCLKOn/RGCLKn) are driven low at global or port reset and should stay low until after the port power-down [PORT.CR1.PD](#) and port data path reset [PORT.CR1.RSTDP](#) bits are cleared. The CLAD clock pins CLKA, CLKB and CLKC are the LIU reference clock inputs at global reset. The processor port tri-state output pins (D[15:0], $\overline{\text{RDY}}$, $\overline{\text{INT}}$) are forced into the high impedance state when the $\overline{\text{RST}}$ pin is active, but not when the [GL.CR1.RST](#) bit is active.

After reset, the device will be in the default configuration:: The latched status bits are enabled to be cleared on write. The CLAD is disabled. The global 8KREF and one-second timers are disabled. The line interface is in B3ZS mode and the LIU is disabled and the transmit line pins are also disabled. The frame mode is DS3 C-bit with automatic downstream AIS on LOS or OOF is enabled and automatic RDI on LOF, LOS, SEF or AIS is enabled

and automatic FEBE is enabled. Transmit clock comes from the CLAD CLKA pin. The pin inversion on all pins is disabled.

Individual blocks are reset and powered down when not used determined by the settings in the line mode bits [PORT.CR2.LM\[2:0\]](#) and framer mode bits [PORT.CR2.FM\[2:0\]](#).

10.4 Global Resources

10.4.1 Clock Rate Adapter (CLAD)

The clock rate adapter is used to create multiple clocks for LIU reference clocks or transmit clocks from a single clock reference input on the CLKA pin. The clock frequency applied to this pin must be at the DS3 (44.736 MHz), E3 (34.368 MHz) and STS-1 (51.84 MHz) clock rates. Given one of these clocks the other two clocks will be generated. The internally generated signals can be driven on output pins (CLKB and CLKC) for external use.

The receive LIU is supplied a reference clock from the CLAD. The receive LIU selects the clock frequency based upon the mode the user selects via the FM bits. The CLAD output is also available as a transmit clock source if selected via the [PORT.CR2.CLADC](#) register bit.

The user must supply at least one of the three rates (DS3, E3, STS-1) to the CLKA pin. The CLAD[3:0] bits inform the PLL of the frequency applied to the pins. Selection of the output clock of the CLAD applied to the LIU and optionally the transmitter is controlled by the FM bits (located in [PORT.CR2](#)). The CLAD allows maximum flexibility to the user. The user may supply any of the three clock rates and use the CLAD to convert the rate to the particular clock rate needed for his application.

Figure 10-6. CLAD Block

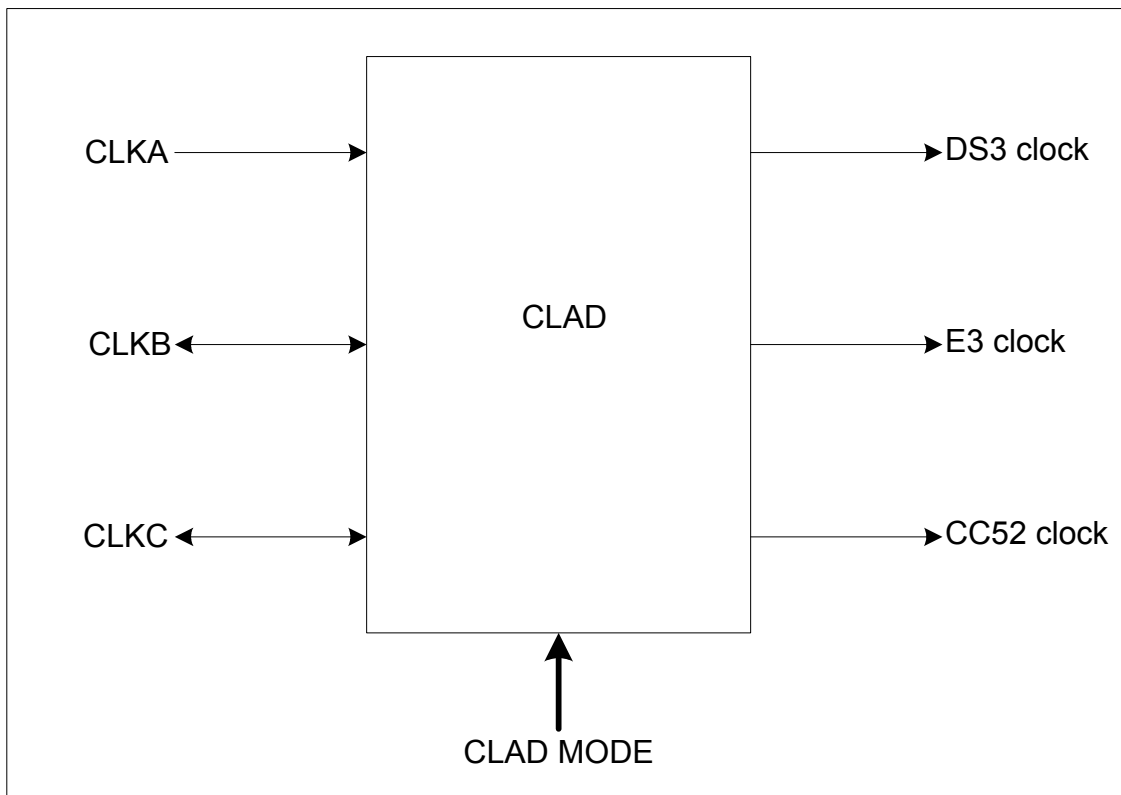

The clock rate adapter can also be disabled and all three clocks supplied externally using the CLKA, CLKB and CLKC pins as clock inputs. When the CLAD is disabled, the three reference clocks DS3, E3 and STS-1 will need to be applied to the CLKA, CLKB and CLKC pins, respectively. If any of the three frequencies is not required, it does not need to be applied to the CLAD CLK pins.

The CLAD MODE inputs to the clock rate adapter are composed of CLAD[3:0] control bits (located in the [GL.CR2](#) Register) which determines which pins are input and output and which clock rate is on which pin. When CLAD[3:0]=00XX, the PLL circuits are disabled and the signals on the input clock pins are used as the internal LIU reference clocks. When CLAD[3:0]=(01XX or 10XX or 11XX), none, one or two PLL circuits are enabled to generate the required clocks as determined by the CLAD[3:0] bits and the framing mode (FM[2:0]) and the line mode (LM[2:0]) control bits. If a clock rate is not required on the CLAD output clock pins or for a reference clock for any of the LIU, then the PLL used to generate that clock is disabled and powered down.

For example, in a design that only has the ports running at DS3 rates, then CLAD[3:0] can be set = 0100 and the DS3 clock signal on the CLKA pin will be used as the DS3 LIU reference clock and no PLL circuit will be disabled.

Table 10-11. CLAD IO Pin Decode

GL.CR2 . CLAD[3:0]	CLKA PIN	CLKB PIN	CLKC PIN
00 XX	DS3 clock input	E3 clock input	STS-1 clock input
01 00	DS3 clock input	Low output	Low output
01 01	DS3 clock input	E3 clock output	Low output
01 10	DS3 clock input	Low output	STS-1 clock output
01 11	DS3 clock input	STS-1 clock output	E3 clock output
10 00	E3 clock input	Low output	Low output
10 01	E3 clock input	DS3 clock output	Low output
10 10	E3 clock input	Low output	STS-1 clock output
10 11	E3 clock input	STS-1 clock output	DS3 clock output
11 00	STS-1 clock input	Low output	Low output
11 01	STS-1 clock input	E3 output	Low output
11 10	STS-1 clock input	Low output	DS3 clock output
11 11	STS-1 clock input	DS3 clock output	E3 clock output

10.4.2 8 kHz Reference Generation

The global 8KREF signal is used to generate the one-second-reference signal by dividing it by 8000. This signal can be derived from almost any clock source on the chip as well as the general-purpose IO pin GPIO4. The port 8KREF signal can be sourced from either the global 8KREF signal or from the transmit or receive port clock or from the receive 8KREF signal. The minimum input frequency stability of the 8KREF input pin is +/- 500 ppm.

The global 8KREF signal can come from an external 8000 Hz reference connected to the GPIO4 general-purpose IO pin by setting the [GL.CR2](#).G8KIS bit. The global 8KREF signal can be output on the GPIO2 general-purpose IO pin when the [GL.CR2](#).G8KOS bit is set.

The global 8KREF signal can be derived from the CLAD PLL or pins or come from any of the port 8KREF signals by clearing [GL.CR2](#).G8KIS bit and selecting the source using the [GL.CR2](#).G8KRS[2:0] bits.

The port 8KREF signal can be derived from the transmit clock input pin or from the receive LIU or input clock pin. The [PORT.CR3](#).P8KRS[1:0] bits are used to select which source.

The 8KREF 8.000 kHz signal is a simple divisor of 44736 kHz (DS3 divided by 5592) or 33368 kHz (E3 divided by 4296). The correct divisor for the port 8KREF source is selected by the mode the port is configured for. The CLAD clock chosen for the clock source selects the correct divisor for the global 8KREF. The 8KREF signal is only as accurate as the clock source chosen to generate it.

[Table 10-12](#) lists the selectable sources for global 8 kHz reference sources.

Table 10-12. Global 8 kHz Reference Source Table

<u>GL.CR2.</u> G8KIS	<u>GL.CR2.</u> G8KRS[2:0]	Source
0	000	None, the 8KHZ divider is disabled.
0	001	Derived from CLAD DS3 clock output or CLKA pin if CLAD is disabled. (Note: CLAD is disabled after reset)
0	010	Derived from CLAD E3 clock output or CLKB pin if CLAD is disabled
0	011	Derived from CLAD STS-1 clock output or CLKC pin if CLAD is disabled
0	100	Port 1 8KREF source selected by P8KRS[1:0]
0	101	Port 2 8KREF source selected by P8KRS[1:0]
0	110	Port 3 8KREF source selected by P8KRS[1:0]
0	111	Port 4 8KREF source selected by P8KRS[1:0]
1	XXX	GPIO4 pin

[Table 10-13](#) lists the selectable sources for port 8 kHz reference sources.

Table 10-13. Port 8 kHz Reference Source Table

<u>PORT.CR3.</u> P8KRS[1:0]	Source
0X	Undefined
10	Internal receive framer clock
11	Internal transmit framer clock

The 8 kHz reference logic tree is shown below.

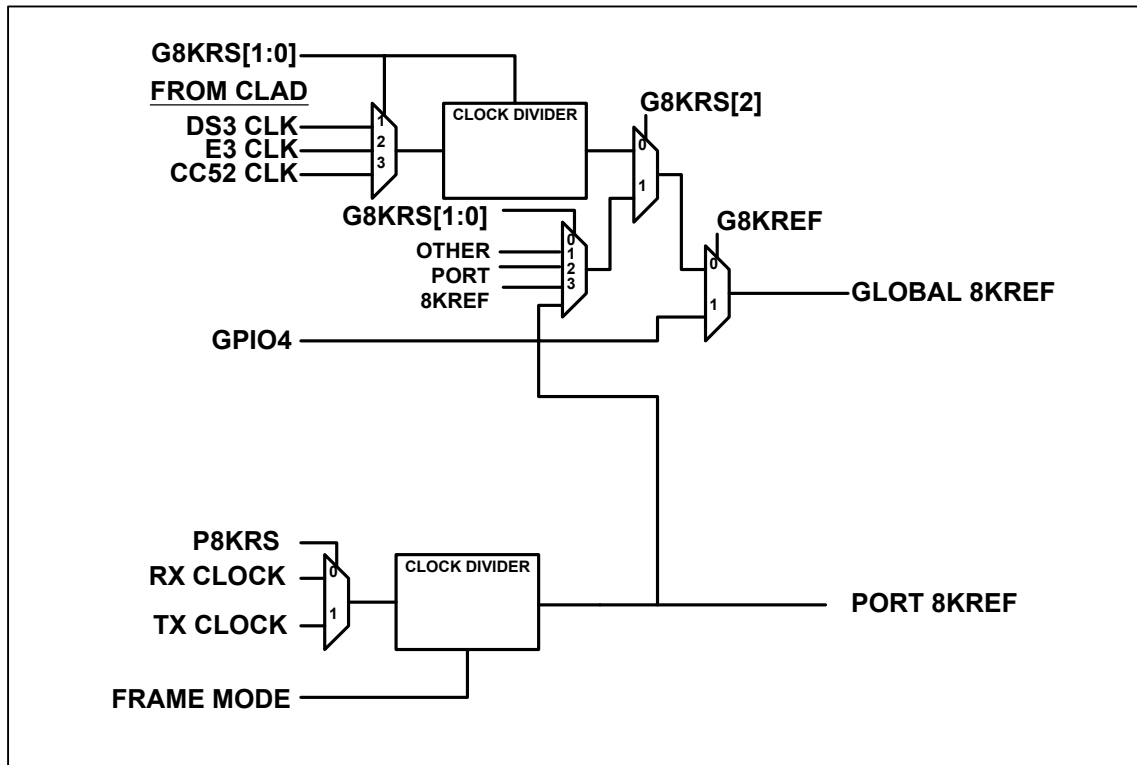
Figure 10-7. 8KREF Logic

10.4.3 One Second Reference Generation

The one-second-reference signal is used as an option to update the performance registers on a precise one-second interval. The generated internal signal should be about 50% duty cycle and it is derived from the Global 8 kHz reference signal by dividing it by 8000. The low to high edge on this signal will set the [GL.SRL.ONESL](#) latched one second detect bit which can generate an interrupt when the [GL.SRIE.ONESIE](#) interrupt enable bit is set. The low to high edge can also be used to generate performance monitor updates when [GL.CR1.GPM\[1:0\]=1X](#).

10.4.4 General-Purpose IO Pins

There are eight general-purpose IO pins that can be used for general IO, global signals and per port alarm signals. Each pin is independently configurable to be a general-purpose input, general-purpose output, global signal or port alarm. Two of the GPIO pins are assigned to each port and can be programmed to output one or two alarm statuses using one or two GPIO pins. One of the two pins assigned to each port can be programmed as global input or output signals. When the device is bonded out (or has ports powered down) to have 1, 2 or 3 ports active, the GPIO pins associated with the disabled ports will still operate as either general-purpose inputs, general-purpose outputs or global signals. When the ports are disabled and [GL.GIOCR.GPIOx\[1:0\] = 01](#), the GPIO pin will be an output driving low. The 8KREFI, TMEI, and PMU signals that can be sourced by the GPIO pin will be driven low into the core logic when the GPIO pin is not selected for the source of the signal.

[Table 10-14](#) lists the purpose and control thereof of the General-Purpose IO Pins.

Table 10-14. GPIO Global Signals

Pin	Global signal	Control bit
GPIO2	8KREFO output	GL.CR2.G8KOS
GPIO4	8KREFI input	GL.CR2.G8KIS
GPIO6	TMEI input	GL.CR1.MEIMS
GPIO8	PMU input	GL.CR1.GPM[1:0]

[Table 10-15](#) describes the selection of mode for the GPIO Pins.

Table 10-15. GPIO Pin Global Mode Select Bits

n = port 1 to 4, x = A or B, valid when a GPIO pin is not selected for a global signal

GL.GIOCR.GPIOnSx	GPIO pin mode
00	Input
01	Port alarm status selected by port GPIO
10	Output logic 0
11	Output logic 1

[Table 10-16](#) lists the various port alarm monitors that can be output on the GPIO pins. The GPIO(A/B)[3:0] bits are located in the [PORT.CR4](#) Register.

Table 10-16. GPIO Port Alarm Monitor Select

PORT.CR4 GPIO(A/B)[3:0]	LINE LOS	DS3/E3 OOF	DS3/E3 LOF	DS3/E3 AIS	DS3/E3 RAI	DS3 IDLE
0000	X					
0001		X				
0010			X			
0011				X		
0100					X	
0101						X
0110						
0111						
1000						
1001						
1010						
1011	X		X	X		
1100						
1101	X		X	X		
1110					X	X
1111	X	X	X	X	X	X

10.4.5 Performance Monitor Counter Update Details

The performance monitor counters are designed to count at least one second of events before saturating to the maximum count. There is a status bit associated with some of the performance monitor counters that is set when the its counter is greater than zero, and a latched status bit that gets set when the counter changes from zero to one. There is also a latched status bit that gets set on every event that causes the error counter to increment.

There is a read register for each performance monitor counter. The count value of the counter gets loaded into this register and the counter is cleared when the update-clear operation is performed. If there is an event to be counted at the exact moment (clock cycle) that the counter is to be cleared then the counter will be set to a value of one so that that event will be counted.

The Performance Monitor Update signal affects the counter registers of the following blocks: the BERT, the DS3/E3 framer, the Line Encoder/Decoder.

The update-clear operation is controlled by the Performance Monitor Update signal (PMU). The update-clear operation will update the error counter registers with the value of the error counter and also reset each counter. The PMU signal can be created in hardware or software. The hardware sources can come from the one-second counter or one of the general-purpose IO pins, which can be programmed to source this signal. The software sources can come from one of the per-port control register bits or one of the global control register bits. When using the software update method, the PMU control bit should be set to initiate the process and when the PMS status bit gets set, the PMU control bit should be cleared making it ready for the next update. When using the hardware update method, the PMS bit will be set shortly after the hardware signal goes high, and cleared shortly after the hardware signal goes low. The latched PMS signal can be used to generate an interrupt for reading the count registers. If the port is not configured for global PMU signals, the PMS signal from that port should be blocked from affecting the global PMS status.

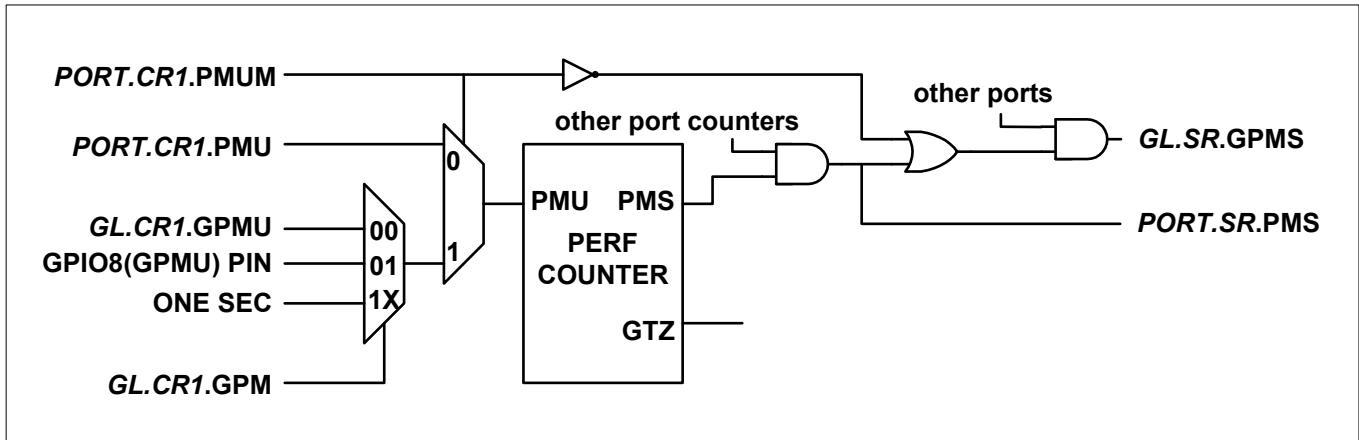
Figure 10-8. Performance Monitor Update Logic

10.4.6 Transmit Manual Error Insertion

Transmit errors can be inserted in some of the functional blocks. These errors can be inserted using register bits in the functional blocks, using the global [GL.CR1.TMEI](#) bit, using the port [PORT.CR1.TMEI](#) bit, or by using the GPIO6 pin configured for TMEI mode.

There is a transmit error insertion register in the functional blocks that allow error insertion. The MEIMS bit controls whether the error is inserted using the bits in the error insertion register or using error insertion signals external to that block. When bit MEIMS=0, errors are inserted using other bits in the transmit error insertion register. When bit MEIMS=1, errors are inserted using a signal generated in the port or global control registers or using the external GPIO6 pin configured for TMEI operation.

Figure 10-9. Transmit Error Insert Logic

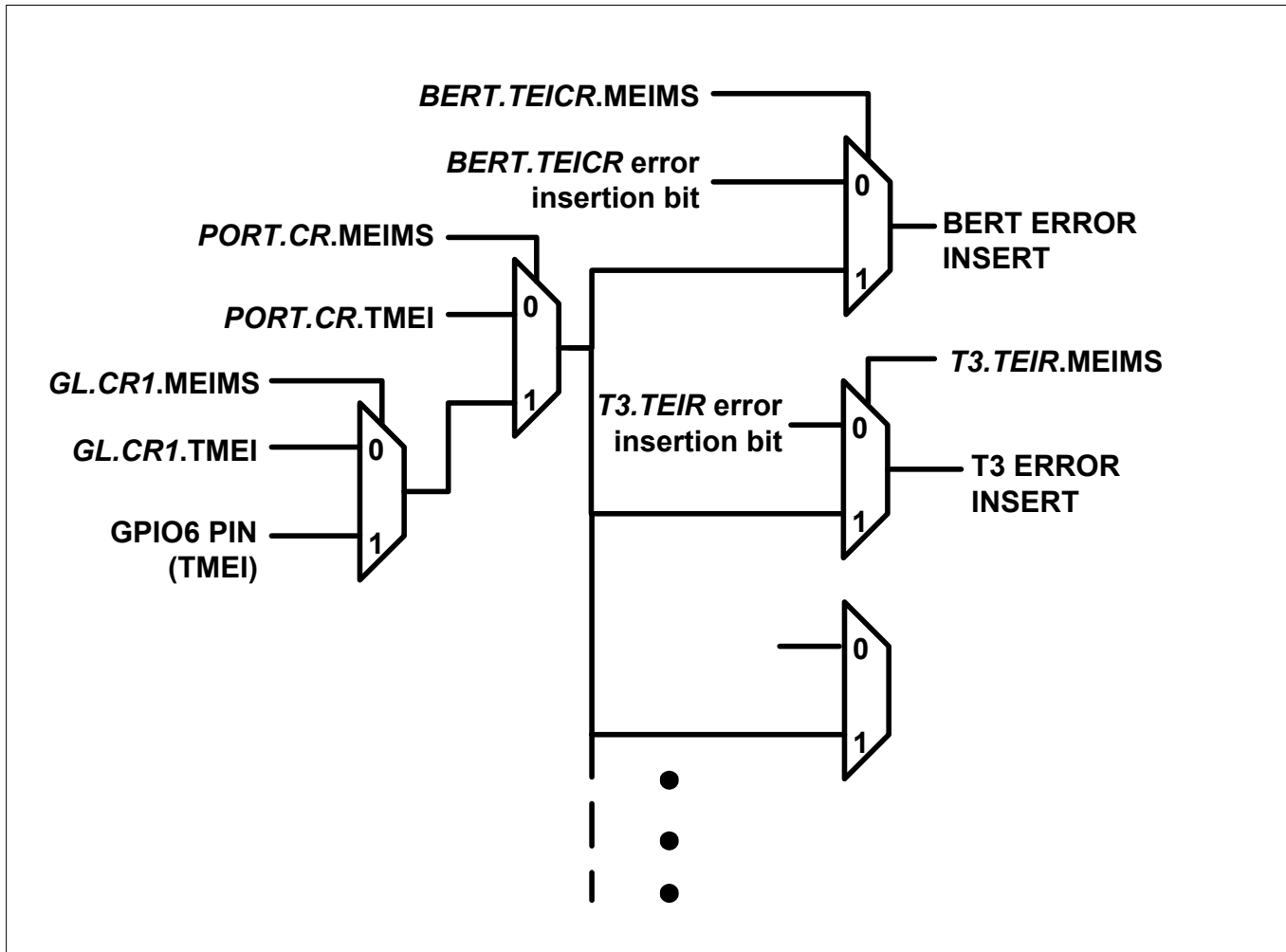

10.5 Per Port Resources

10.5.1 Loopbacks

There are several loop back paths available. The following table lists the loopback modes available for analog loopback (ALB), line loopback (LLB), payload loopback (PLB) and diagnostic loopback (DLB). The LBM bits are located in [PORT.CR4](#).

Table 10-17. Loopback Mode Selections

LBM[2:0]	ALB	LLB	PLB	DLB
000	0	0	0	0
001	1	0	0	0
010	0	1	0	0
011	0	0	1	0
10X	0	0	0	1
110	0	1	0	1
111	0	0	0	1

Figure 10-10 highlights where each loopback mode is located and gives an overall view of the various loopback paths available.

Figure 10-10. Loopback Modes

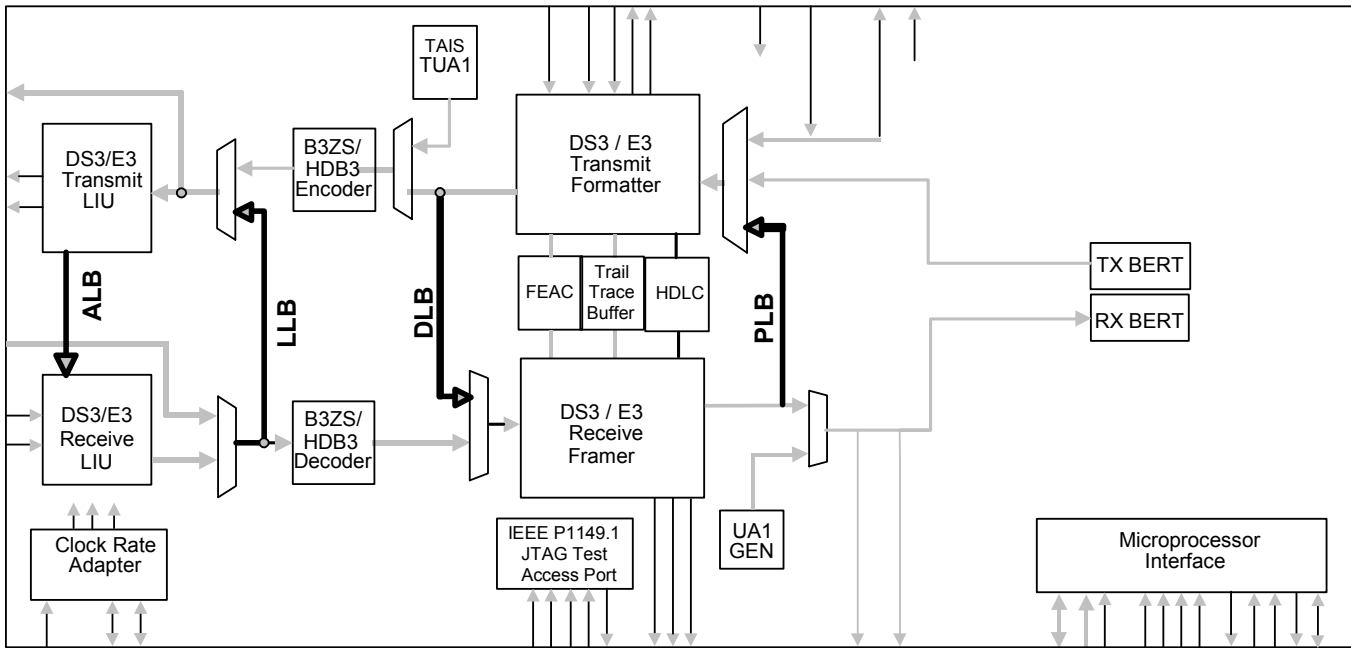

10.5.1.1 Analog Loopback (ALB)

Analog loopback is enabled by setting `PORT.CR4.LBM[2:0] = 001`. Analog loopback mode will not be enabled when the port is configured for loop-timed mode (set via the `PORT.CR3.LOOPT` bit).

The analog loopback is a loopback as close to the pins as possible. When both the TX and RX LIU are enabled, it loops back TXPn and TXNn to RXPn and RXNn, respectively. If the transmit signals on TXPn and TXNn are not terminated properly, this loopback path may have data errors or loss of signal. When the LIU is not enabled, it loops back TLCLKn, TPOSn / TDATn, TNEGn to RLCLKn, RPOSn / RDATn , RNEGn.

Figure 10-11. ALB Mux

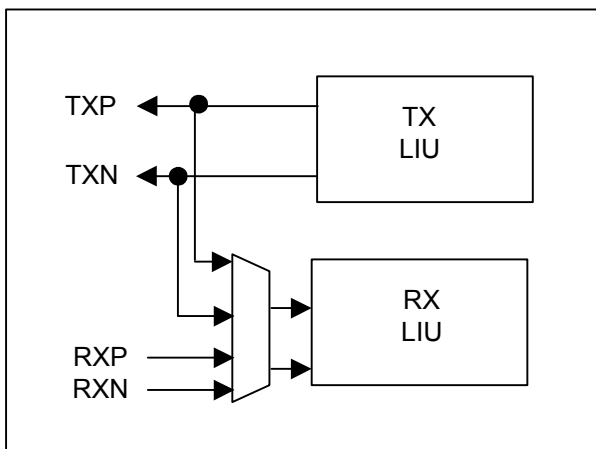

10.5.1.2 Line Loopback (LLB)

Line loopback is enabled by setting [PORT.CR4.LBM\[2:0\]](#) = X10. DLB and LLB are enabled at the same time when [LBM\[2:0\]](#) = 110, and only LLB is enabled when [LBM\[2:0\]](#) = 010.

The clock from the receive LIU or the RLCLKn pin will be output to the transmit LIU or TCLKOn pin. The POS and NEG data from the receive LIU or the RPOSn and RNEGn pin will be sampled with the receive clock to time it to the LIU or pin interface.

When LLB is enabled, unframed all ones AIS can optionally be automatically enabled on the receive data path. This AIS signal will be output on the RSERn pin in SCT modes. When DLB and LLB are enabled, the AIS signal will not be transmitted.

Refer to [Figure 10-10](#).

10.5.1.3 Payload Loopback (PLB)

Payload loopback is enabled by setting [PORT.CR4.LBM\[2:0\]](#) = 011.

The payload loopback copies the payload data from the receive framer to the transmit framer which then re-frames the payload before transmission. Payload loopback is operational in all framing modes.

When PLB is enabled, unframed all ones AIS transmission can optionally be automatically enabled on the receive data path. This AIS signal will be output on the RSER. In all PLB modes, the TSOFln input pin is ignored.

The external transmit output pins TDENn and TSOFOOn/TDENn can optionally be disabled by forcing a zero when PLB is enabled.

Refer to [Figure 10-10](#).

10.5.1.4 Diagnostic Loopback (DLB)

Diagnostic loopback is enabled by setting [PORT.CR4.LBM\[2:0\]](#) = 1XX. DLB and LLB are enabled at the same time when [LBM\[2:0\]](#) = 110, only DLB is enabled when [LBM\[2:0\]](#) = 10X or 111.

The Diagnostic loopback sends the transmit data, before line encoding, back to the receive side.

Transmit AIS can still be enabled using [PORT.CR1.LAIS\[2:0\]](#) even when DLB is enabled.

Refer to [Figure 10-10](#).

10.5.2 Loss Of Signal Propagation

The Loss Of Signal (LOS) is detected in the line decoder logic. In unipolar (UNI) line interface modes LOS is never detected. The LOS signal from the line decoder is sent to the DS3/E3 framer and the top-level payload AIS logic except when DLB is activated. When DLB is activated the LOS signal to the framer and AIS logic is never active. The LOS status in the line decoder status register is valid in all frame and loop back modes, though it is always off in the line interface is in the UNI mode.

10.5.3 AIS Logic

There is AIS logic in both the framers and at the top-level logic of the ports. The framer AIS is enabled by setting the TAIS bit in the appropriate framer transmit control register (T3, E3-G.751, E3-G.832, or Clear Channel). The top level AIS is enabled by setting the [PORT.CR1.LAIS\[2:0\]](#) bits (see [Table 10-18](#)). The AIS signal is an unframed all ones pattern or a DS3 framed 101010... pattern depending on the [FM\[2:0\]](#) mode bits. The DS3 Framed Alarm Indication Signal (AIS) is a DS3 signal with valid F-bits, M-bits, and P-bits (P1 and P2). The X-bits (X1 and X2) are set to one, all C-bits (CXY) are set to zero, and the payload bits are set to a 1010 pattern starting with a one immediately after each overhead bit. The DS3 framed AIS pattern is only available in DS3 modes. The unframed all ones pattern is available in all framing modes including the DS3 modes. The transmit line interface can send both unframed all ones AIS and DS3 framed AIS patterns from either the AIS generator in the framer or the AIS generator at the top level.

The AIS signal generated in the framer can be initiated and terminated without introducing any errors in the signal. When the unframed AIS signal is initiated or terminated, there will be no BPV or CV errors introduced, but there will

be framing errors if a framed mode is enabled. When the DS3 framed AIS signal is initiated or terminated, in addition to no BPV or CV errors, there should be no framing or P-bit (parity) or CP-bit errors introduced.

The AIS signal generated at the top level will not generate BPV errors but may generate P-bit and CP-bit errors when the signal is initiated and terminated. The framed DS3 AIS signal will not cause the far end receiver to re-sync when the signal is initiated, but it may cause a re-sync when terminated if the DS3 frame position in the framer is changed while the DS3 AIS signal is being generated. A sequence of events can be executed which will enable the initiation and termination of DS3 AIS or unframed all ones at the top level without any errors introduced. The sequence will only work when the automatic AIS generation is not enabled. CV and P-bit errors can occur when AIS is automatically generated and cannot be avoided. This sequence to generate an error free DS# AIS at the top level is to have the DS3 AIS or unframed all ones signal initiate in the DS3 framer, and a few frames sent before initiating or terminating the DS3 AIS or unframed all ones at the top level. After the top level AIS signal is activated, the AIS signal in the framer can be terminated, DLB activated and diagnostic patterns generated. The DS3 AIS signal generated at the top level will not change frame alignment after starting even if the DS3 frame position in the framer is changed.

The transmit line AIS generator at the top level can generate AIS signals even when the framer is looped back using DLB, but not when the line is looped back using LLB. The AIS signal generated in the framer will be looped back to the receive side when DLB is activated.

The receive framer can detect both unframed all ones AIS and DS3 framed AIS patterns. When in DS3 framing modes, both framed DS3 AIS and unframed all ones can be detected. In E3 framing modes E3 AIS, which is unframed all ones, is detected.

The receive payload interface going to the RSERn pin or the BERT logic can have an unframed all ones AIS signal replacing the receive signal, this is called Payload AIS. The all ones AIS signal is generated from either the DS3/E3 framer or the downstream top level unframed all ones AIS generator. The unframed all ones AIS signal generated in the framer will be looped back to the transmit side when PLB is activated. The unframed all ones AIS signal generated at the top level will be sent to the RSERn pin and other receive logic, but not to the transmit side while PLB is activated. The top level AIS generator is used when a downstream AIS signal is desired while payload loop back is activated and is enabled by default after rest and must be cleared during configuration. Note that the downstream AIS circuit in the framer, when a DS3 mode is selected, enforces the OOF to be active for 2.5 ms before activating when automatic AIS in the framer is enabled. The top level downstream AIS will be generated with no delay when OOF is detected when automatic AIS at the top level is enabled.

There is no detection of any AIS signal on the transmit payload signal from the TSERn pin or anywhere on the transmit data path.

The transmit AIS generator at the top level can also be activated with a software bit or automatically when DLB is activated. The receive AIS generator in the framer can be activated with a software bit, and automatically when AIS, LOS or OOF are detected. The receive payload AIS generator at the top level can be activated with a software bit or automatically when LOS, DS3/E3 OOF, LLB or PLB is activated.

Figure 10-12 shows the AIS signal flow through the device.

Figure 10-12. AIS Signal Flow

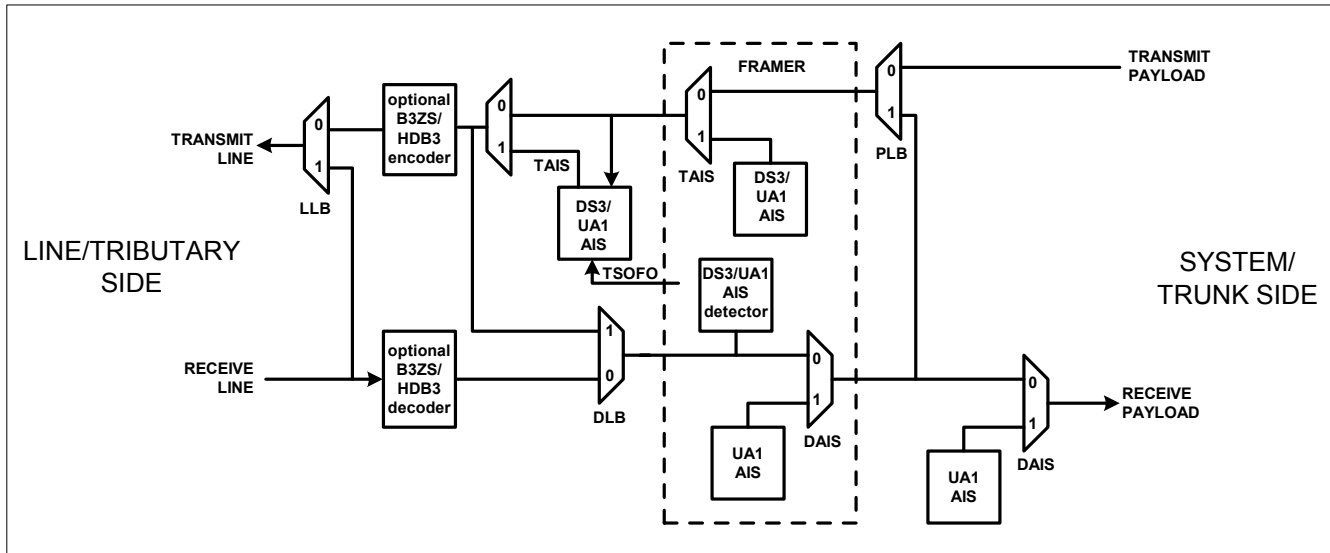

Table 10-18 lists the LAIS decodes for various line AIS enable modes.

Table 10-18. Line AIS Enable Modes

LAIS[1:0] PORT.CR1	Frame Mode	Description	AIS Code
00	DS3	Automatic AIS when DLB is enabled (PORT.CR4.LBM = 1XX)	DS3AIS
00	E3	Automatic AIS when DLB is enabled	UA1
01	Any	Send UA1	UA1
10	DS3	Send AIS	DS3AIS
10	E3	Send AIS	UA1
11	Any	Disable	none

[Table 10-19](#) lists the PAIS decodes for various payload AIS enable modes.

Table 10-19. Payload (Downstream) AIS Enable Modes

PAIS[2:0] PORT.CR1	When AIS is sent	AIS Code
000	Always	UA1
001	When LLB (no DLB) active	UA1
010	When PLB active	UA1
011	When LLB(no DLB) or PLB active	UA1
100	When LOS (no DLB) active	UA1
101	When OOF active	UA1
110	When OOF, LOS, LLB (no DLB), or PLB active	UA1
111	Never	none

10.5.4 Loop Timing Mode

Loop timing mode is enabled by setting the *PORT.CR3.LOOPT* bit. This mode replaces the clock from the *TCLKIn* pin with the internal receive clock from either the *RLCLKn* pin if the RX LIU is disabled, or the recovered clock from the RX LIU if it is enabled. The loop-timing mode can be activated in any framing or line interface mode.

10.5.5 HDLC Overhead Controller

The data signal to the receive HDLC controller will be forced to a one while still being clocked when the framer (DS3, E3), to which the HDLC is connected, detects LOF or AIS. Forcing the data signal to all ones will cause an HDLC packet abort if the data started to look like a packet instead of allowing a bad, and possibly very long, HDLC packet.

10.5.6 Trail Trace

There is a single Trail Trace controller for use in line maintenance protocols. The E3-G.832 framer has access to the trail trace controller.

10.5.7 BERT

There is a Bit Error Rate Test (BERT) circuit for each port for use in generating and detecting test signals in the payload bits. The BERT can generate and detect PRBS patterns up to $2^{32}-1$ bits as well as repeating patterns up to 32 bits long. The generated BERT signal replaces the data on the *TSERn* pin in SCT modes when the BERT is enabled by setting the *PORT.CR1.BENA*.

When the BERT is enabled The *TDENn* and *RDENn* pins will still be active but the data on the *TSERn* pin will be discarded.

10.5.8 SCT port pins

The SCT port pins have multiple functions based on the framing mode the device is in as well as other pin mode select bits.

10.5.8.1 Transmit SCT port pins

The transmit SCT pins are *TSOFIn*, *TSERn*, *TSOFOn* / *TDENn*, and *TCLKOn* / *TGCLKn*. They have different functions based on the framing mode and other pin mode bits. Unused input pin functions should drive a logic zero into the device circuits expecting a signal from that pin. The control bits that configure the pins' modes are [PORT.CR2.FM\[2:0\]](#), [PORT.CR3.TPFPE](#), [PORT.CR3.TSOFOS](#) and [PORT.CR3.TCLKS](#).

[Table 10-20](#) to [Table 10-22](#) describe the function selected by the FM bits and other pin mode bits for the multiplexed pins.

Table 10-20. TSOFIn Input Pin Functions

FM[2:0] PORT.CR2	Pin function
0XX (FSCT)	TSOFIn
1XX (FBM)	Not used

Table 10-21. TSOFOn/TDENn/Output Pin Functions

FM[2:0] PORT.CR2	TSOFOS PORT.CR3	Pin function
0XX (FSCT)	0	TDENn
0XX (FSCT)	1	TSOFOn
1XX (FBM)	X	Low

Table 10-22. TCLKOn/TGCLKn Output Pin Functions

FM[2:0] PORT.CR2	TCLKS PORT.CR3	Pin function	Gap source
0XX (FSCT)	0	TGCLKn	TDENn
0XX (FSCT)	1	TCLKOn	none
1XX (FBM)	X	TCLKOn	none

10.5.8.2 Receive SCT port pins

The receive SCT pins are RSERn, RSOFOn / RDENn and RCLKOn / RGCLKn. They have different functions based on the framing mode and other pin mode bits. Unused input pin functions should drive a logic zero into the device circuits expecting a signal from that pin. The control bits that configure these pins are [PORT.CR2.FM\[2:0\]](#), [PORT.CR3.RPFPE](#), [PORT.CR3.RSOFOS](#) and [PORT.CR3.RCLKS](#).

[Table 10-23](#) to [Table 10-24](#) describe the function selected by the FM bits and other pin mode bits for the multiplexed pins.

Table 10-23. RSOFOn/RDENn Output Pin Functions

FM[2:0] PORT.CR2	RSOFOS PORT.CR3	Pin function
0XX (FSCT)	0	RDENn
0XX (FSCT)	1	RSOFOn
1XX (CLR)	X	Low
1XX (CSCT)	X	High

Table 10-24. RCLKOn/RGCLKn Output Pin Functions

FM[2:0] PORT.CR2	RCLKS PORT.CR3	Pin function	Gap source
0XX (FSCT)	0	RGCLKn	RDENn
0XX (FSCT)	1	RCLKOn	none
1XX (FBM)	X	RCLKOn	none

10.5.9 Framing Modes

The framing modes are selected independently of the line interface modes using the *PORT.CR2.FM[2:0]* control bits. Different blocks are used in different framing modes. The bit error test (BERT) function can be enabled in any mode. The LIU, JA and line encoder/decoder blocks are selected by the line mode (LM[2:0]) code.

Table 10-25. Framing Mode Select Bits FM[2:0]

FM[2:0]	Description	Line Code	Figure
000	DS3 C-bit Framed	B3ZS/AMI/UNI	Figure 6-1
001	DS3 M13 Framed	B3ZS/AMI/UNI	Figure 6-1
010	E3 G.751 Framed	HDB3/AMI/UNI	Figure 6-1
011	E3 G.832 Framed	HDB3/AMI/UNI	Figure 6-1
100	DS3 Rate Clear Channel	B3ZS/AMI/UNI	Figure 6-2
11X	E3 Rate Clear Channel	HDB3/AMI/UNI	Figure 6-2

10.5.10 Line Interface Modes

The line interface modes can be selected semi-independently of the framing modes using the *PORT.CR2.LM[2:0]* control bits. The major blocks controlled are the transmit LIU (TX LIU), receive LIU (RX LIU), jitter attenuator (JA) and the line encoder/decoder. The line encoder/decoder is used for B3ZS, HDB3 and AMI line interface encoding modes. The line encoder-decoder block is not used for line encoding or decoding in the UNI mode but the BPV counter in it can be used to count external pulses on the RNEGn / RCLVn pin. The jitter attenuator (JA) can be off (OFF) or put in either the transmit (TX) or receive (RX) path with the TX LIU or RX LIU. Both TX LIU and RX LIU can be enabled (ON) or disabled (OFF).

The “Analog Loop Back” (ALB) is available when the LIU is enabled or disabled. It is an actual loop back of the analog positive and negative pulses from the TX LIU to the RX LIU when the LIU is enabled. If the LIU is disabled, it is a digital loop back of the TLCLK, TPOS, TNEG signals to the RLCLK, RPOS and RNEG signals.

When the line is configured for B3ZS/HDB3/AMI line codes, the line codes are determined by the framing mode and the TZCDS and RZCDS bits control the AMI line mode selection bits in the line encoder/decoder blocks. The DS3 modes select the B3ZS line coding, the E3 modes select the HDB3 line codes. Refer to [Table 10-26](#) for configuration.

Table 10-26. Line Mode Select Bits LM[2:0]

LINE.TCR.TZSD & LINE.RCR.RZSD	LM[2:0] (PORT.CR2)	Line Code	LIU	JA
0	000	B3ZS/HDB3	OFF	OFF
0	001	B3ZS/HDB3	ON	OFF
0	010	B3ZS/HDB3	ON	TX
0	011	B3ZS/HDB3	ON	RX
1	000	AMI	OFF	OFF
1	001	AMI	ON	OFF
1	010	AMI	ON	TX
1	011	AMI	ON	RX
X	1XX	UNI	OFF	OFF

10.6 DS3/E3 Framer / Formatter

10.6.1 General Description

The Receive DS3/E3 Framer receives a unipolar DS3/E3 signal, determines frame alignment and extracts the DS3/E3 overhead in the receive direction. The Transmit DS3/E3 Formatter receives a DS3/E3 payload, generates framing, inserts DS3/E3 overhead, and outputs a unipolar DS3/E3 signal in the transmit direction.

The Receive DS3/E3 Framer receives a DS3/E3 signal from the Receive LIU or RDATn (or RPOSn and RNEGn), determines the frame alignment, extracts the DS3/E3 overhead, and outputs the payload with frame and overhead

The Transmit DS3/E3 Formatter receives a DS3/E3 payload on TSERN, generates a DS3/E3 frame, optionally inserts DS3/E3 overhead, and transmits the DS3/E3 signal.

Refer to [Figure 10-13](#) for the location of the DS3/E3 Framer/Formatter blocks in the DS3174, 3, 2, 1 devices.

Figure 10-13. Framer Detailed Block Diagram

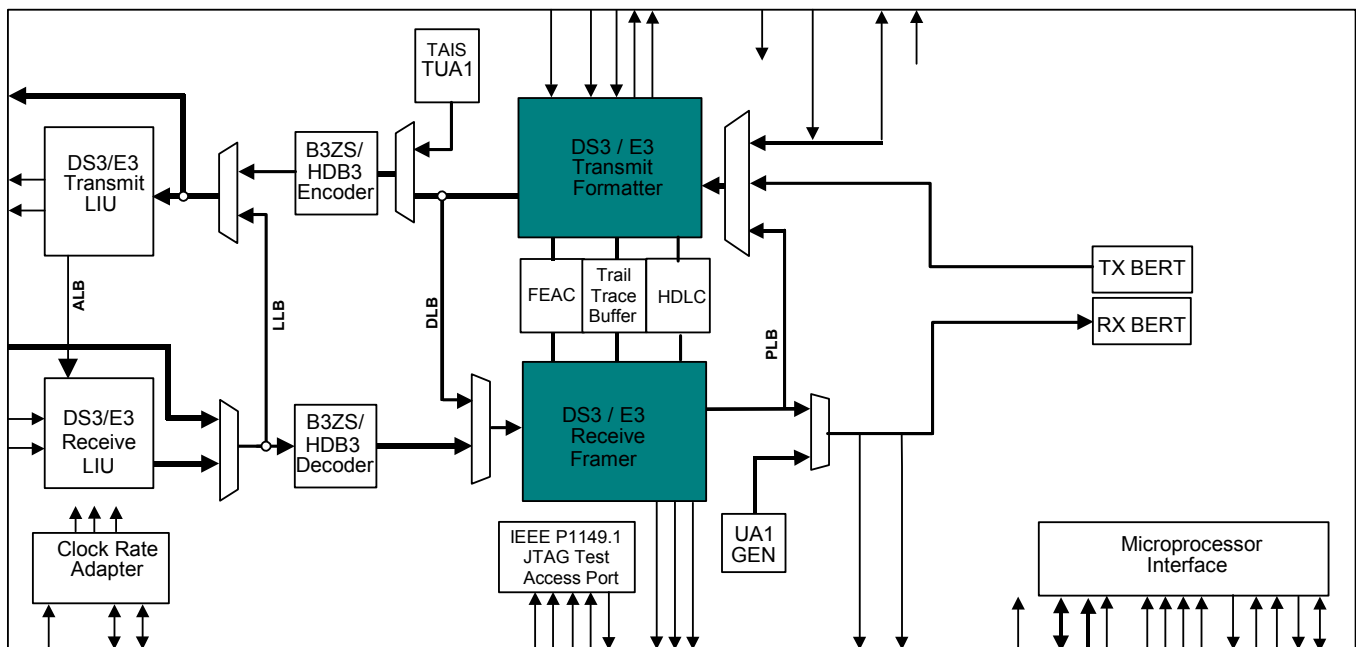

10.6.2 Features

10.6.2.1 Transmit Formatter

- **Programmable DS3 or E3 formatter** – Accepts a DS3 (M23 or C-bit) or E3 (G.751 or G.832) signal and performs DS3/E3 overhead generation.
- **Arbitrary framing format support** – Generates a signal with an arbitrary framing format. The line overhead/stuff periods are added into the data stream using an overhead mask signal.
- **Generates alarms and errors** – DS3 alarm conditions (AIS, RDI, and Idle) and errors (framing, parity, and FEBC), or E3 alarm conditions (AIS and RDI/RAI) and errors (framing, parity, and REI) can be inserted into the outgoing data stream.
- **Externally controlled serial DS3/E3 overhead insertion port** – Can insert all DS3 or E3 overhead via a serial interface. DS3/E3 overhead insertion is fully controlled via the serial overhead interface.
- **HDLC overhead insertion** – An HDLC channel can be inserted into the DS3 or E3 data stream.
- **FEAC insertion** – A FEAC channel can be inserted into the DS3 or E3 data stream.
- **Trail Trace insertion** – Inputs and inserts the G.832 E3 TR byte.

10.6.2.2 Receive Framer

- **Programmable DS3 or E3 framer** – Accepts a DS3 (M23 or C-bit) or E3 (G.751 or G.832) signal and performs DS3/E3 overhead termination.
- **Arbitrary framing format support** – Accepts a signal with an arbitrary framing format. The Line overhead/stuff periods are removed from the data stream using an overhead mask signal.
- **Detects alarms and errors** – Detects DS3 alarm conditions (SEF, OOMF, OOF, LOF, COFA, AIS, AIC, RDI, and Idle) and errors (framing, parity, and FEBE), or E3 alarm conditions (OOF, LOF, COFA, AIS, and RDI/RAI) and errors (framing, parity, and REI).
- **Serial DS3/E3 overhead extraction port** – Extracts all DS3 or E3 overhead and outputs it on a serial interface.
- **HDLC overhead extraction** – An HDLC channel can be extracted from the DS3 or E3 data stream.
- **FEAC extraction** – A FEAC channel can be extracted from the DS3 or E3 data stream.
- **Trail Trace extraction** – Extracts and outputs the G.832 E3 TR byte.

10.6.3 Transmit Formatter

The Transmit Formatter receives a DS3 or E3 data stream and performs framing generation, error insertion, overhead insertion, and AIS/Idle generation for C-bit DS3, M23 DS3, G.751 E3, or G.832 E3 framing protocols.

The bits in a byte are transmitted MSB first, LSB last. When they are input serially, they are input in the order they are to be transmitted. The bits in a byte in an outgoing signal are numbered in the order they are transmitted, 1 (MSB) to 8 (LSB). However, when a byte is stored in a register, the MSB is stored in the highest numbered bit (7), and the LSB is stored in the lowest numbered bit (0). This is to differentiate between a byte in a register and the corresponding byte in a signal.

10.6.4 Receive Framer

The Receive Framer receives the incoming DS3, or E3, line/tributary data stream, performs appropriate framing, and terminates and extracts the associated overhead bytes.

The Receive Framer processes a C-bit format DS3, M23 format DS3, G.751 format E3, or G.832 format E3 data stream, performing framing, performance monitoring, overhead extraction, and generates downstream AIS, if necessary.

The bits in a byte are received MSB first, LSB last. When they are output serially, they are output MSB first, LSB last. The bits in a byte in an incoming signal are numbered in the order they are received, 1 (MSB) to 8 (LSB). However, when a byte is stored in a register, the MSB is stored in the highest numbered bit (7), and the LSB is stored in the lowest numbered bit (0). This is to differentiate between a byte in a register and the corresponding byte in a signal.

Some bits, bit groups, or bytes (data) are integrated before being stored in a register. Integration requires the data to have the same new data value for five consecutive occurrences before the new data value will be stored in the data register. Unless stated otherwise, integrated data may have an associated unstable indication. Integrated data is considered unstable if the received data value does not match the currently stored (integrated) data value or the previously received data value for eight consecutive occurrences. The unstable condition is terminated when the same value is received for five consecutive occurrences.

10.6.4.1.1 Receive DS3 Framing

DS3 framing determines the DS3 frame boundary. In order to identify the DS3 frame boundary, first the subframe boundary must be found. The subframe boundary is found by identifying the subframe alignment bits F_{X1} , F_{X2} , F_{X3} , and F_{X4} , which have a value of one, zero, zero, and one, respectively. See [Figure 10-14](#). Once the subframe boundary is found, the multiframe frame boundary can be found. The multiframe boundary is found by identifying the multiframe alignment bits M_1 , M_2 , and M_3 , which have a value of zero, one, and zero respectively. The DS3 framer is an off-line framer that only updates the data path frame counters when either an out of frame (OOF) or an out of multiframe (OOMF) condition is present. The use of an off-line framer reduces the average time required to reframe, and reduces data loss caused by burst error. The DS3 framer has a Maximum Average Reframe Time (MART) of approximately 1.0 ms.

Figure 10-14. DS3 Frame Format

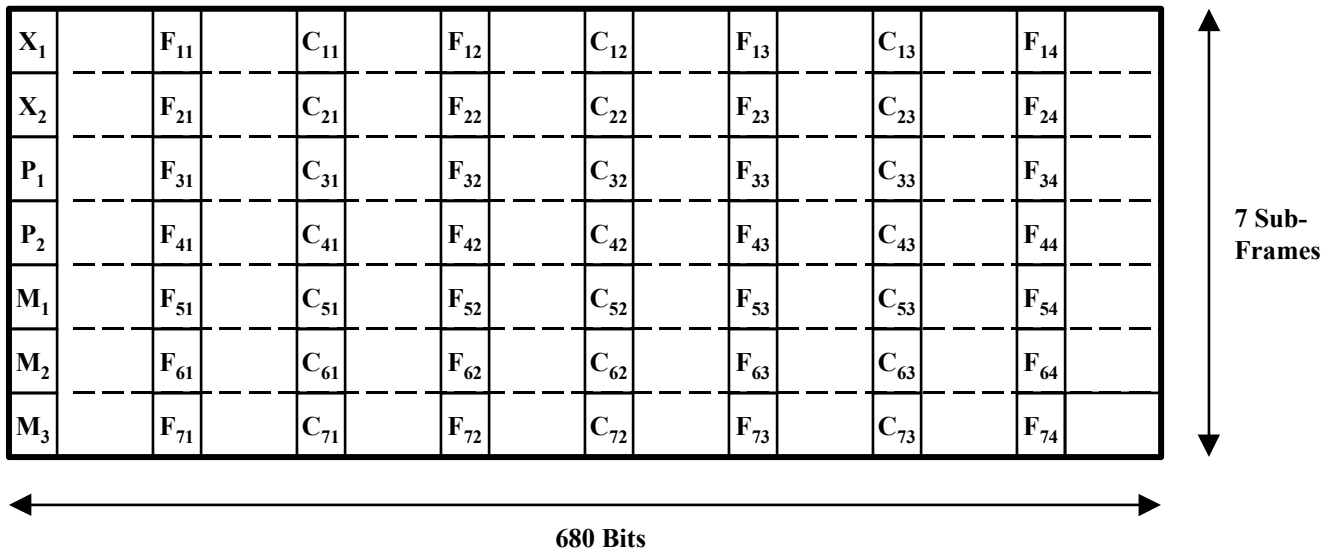

The subframe framer continually searches four adjacent bit positions for a subframe boundary. A subframe alignment bit (F-bit) checker checks each bit position. All four bit positions must fail before any other bit positions are checked for a subframe boundary. There are 170 possible bit positions that must be checked, and four positions are checked simultaneously. Therefore up to 43 checks may be needed to identify the subframe boundary. The subframe framer enables the multiframe frame once it has identified a subframe boundary. Refer to [Figure 10-15](#) for the subframe framer state diagram.

Figure 10-15. DS3 Subframe Framer State Diagram

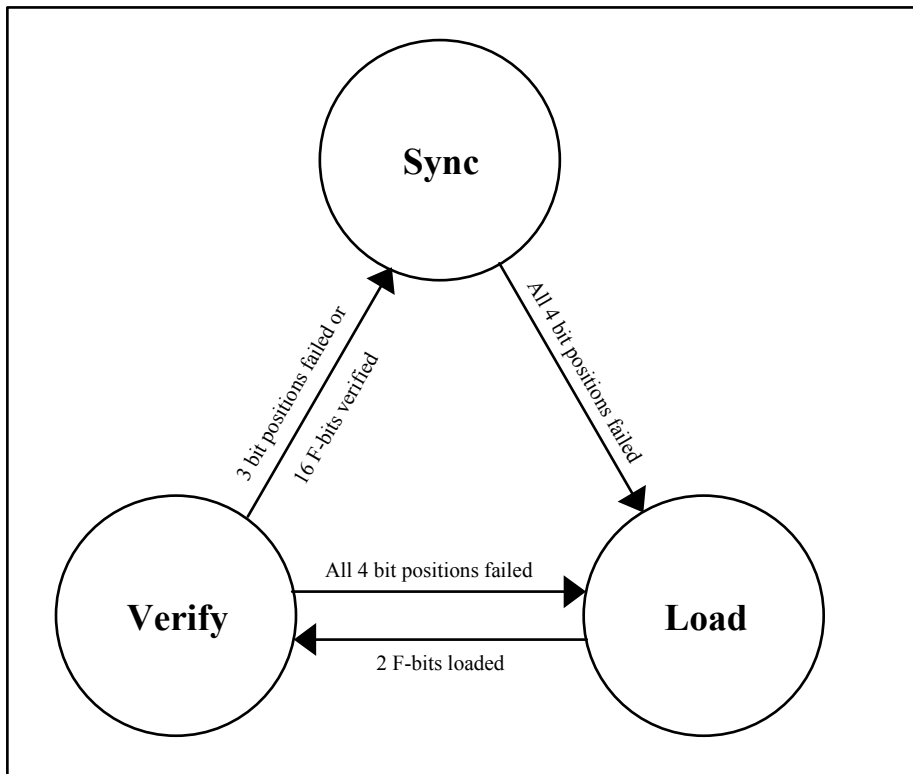

The multiframe framer checks for a multiframe boundary. When the multiframe framer identifies a multiframe boundary, it updates the data path frame counters if either an OOF or OOMF condition is present. The multiframe framer waits until a subframe boundary has been identified. Then, each bit position is checked for the multiframe boundary. The multiframe boundary is found by identifying the three multiframe alignment bits (M-bits). Since there are seven multiframe bits and three bits are required to identify the multiframe boundary, up to 9 checks may be needed to find the multiframe boundary. Once the multiframe boundary is identified, it is checked in each subsequent frame. The data path frame counters are updated if the three multiframe alignment bits are error free, and an OOF or OOMF condition exists. If the multiframe framer checks more than fifteen multiframe bit (X-bits, P-bits, and M-bits) positions without identifying the multiframe boundary, the multiframe framer times out, and forces the subframe framer back into the load state. Refer to Figure 10-16 for the multiframe framer state diagram.

10.6.4.1.2 Receive DS3 Performance Monitoring

Performance monitoring checks the DS3 frame for alarm conditions and errors. The alarm conditions detected are OOMF, OOF, SEF, LOF, COFA, LOS, AIS, Idle, RUA1, and RDI. The errors accumulated are framing, P-bit parity, C-bit parity (C-bit format only), and Far-End Block Error (FEBE) (C-bit format only) errors.

An Out Of MultiFrame (OOMF) condition is declared when a multiframe alignment bit (M-bit) error has been detected in two or more of the last four consecutive DS3 frames, or when a manual resynchronization is requested. An OOMF condition is terminated when no M-bit errors have been detected in the last four consecutive DS3 frames, or when the DS3 framer updates the data path frame counters. Figure 10-16 shows the multiframe framer state diagram.

Figure 10-16. DS3 Multiframe Framer State Diagram

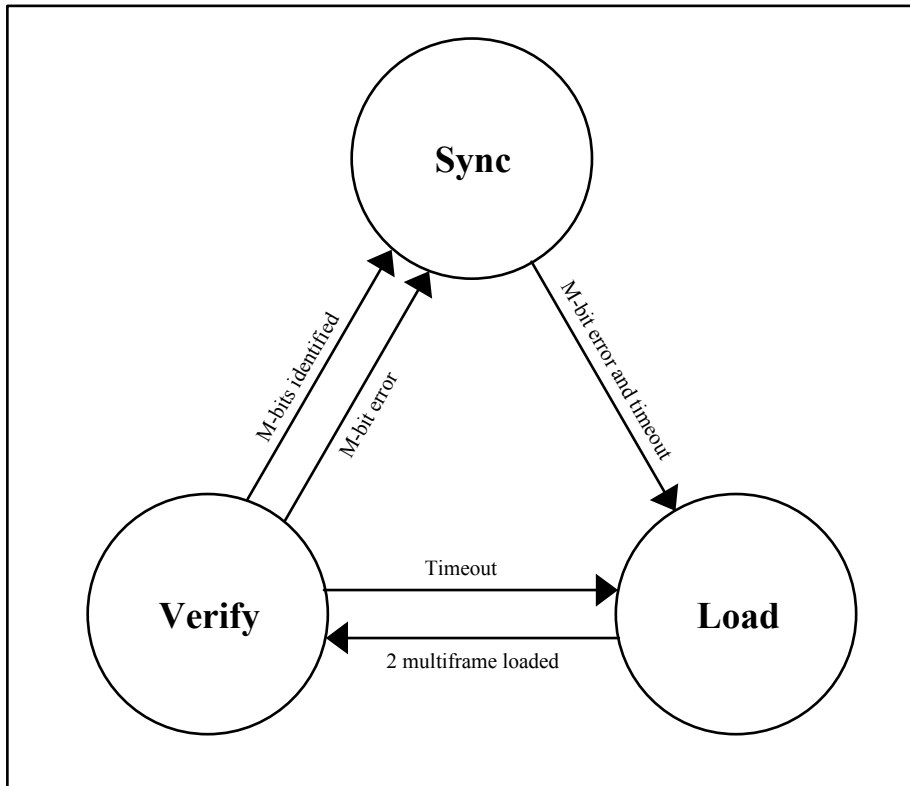

If multiframe alignment OOF is disabled, an Out Of Frame (OOF) condition is declared when three or more out of the last sixteen consecutive subframe alignment bits (F-bits) have been errored, or a manual resynchronization is requested. If multiframe alignment OOF is enabled, an OOF condition is declared when three or more out of the last sixteen consecutive F-bits have been errored, when an OOMF condition is declared, or when a manual resynchronization is requested. If multiframe alignment OOF is disabled, an OOF condition is terminated when none of the last sixteen consecutive F-bits has been errored, or when the DS3 framer updates the data path frame counters. If multiframe alignment OOF is enabled, an OOF condition is terminated when an OOMF condition is not

active and none of the last sixteen consecutive F-bits has been errored, or when the DS3 framer updates the data path frame counters. Multiframe alignment OOF is programmable (on or off).

A Severely Errored Frame (SEF) condition is declared when three or more out of the last sixteen consecutive F-bits have been errored, or when a manual resynchronization is requested. An SEF condition is terminated when an OOF condition is absent.

A Loss Of Frame (LOF) condition is declared by the LOF integration counter when it has been active for a total of T ms. The LOF integration counter is active (increments count) when an OOF condition is present, it is inactive (holds count) when an OOF condition is absent, and it is reset when an OOF condition is absent for T continuous ms. T is programmable (0, 1, 2, or 3). An LOF condition is terminated when an OOF condition is absent for T continuous ms.

A Change Of Frame Alignment (COFA) is declared when the DS3 framer updates the data path frame counters with a frame alignment that is different from the current data path DS3 frame alignment.

A Loss Of Signal (LOS) condition is declared when the B3ZS encoder is active, and it declares an LOS condition. An LOS condition is terminated when the B3ZS encoder is inactive, or it terminates an LOS condition.

An Alarm Indication Signal (AIS) is a DS3 signal with valid F-bits and M-bits. The X-bits (X_1 and X_2) are set to one, the P-bits (P_1 and P_2) are set to zero, all C-bits (C_{xy}) are set to zero, and the payload bits are set to a 1010 pattern starting with a one immediately after each DS3 overhead bit. An AIS signal is present when a DS3 frame is received with valid F-bits and M-bits, both X-bits set to one, both P-bits set to zero, all C-bits set to zero, and all but seven or fewer payload data bits matching the DS3 overhead aligned 1010 pattern. An AIS signal is absent when a DS3 frame is received that does not meet the aforementioned criteria for an AIS signal being present. The AIS integration counter declares an AIS condition when it has been active for a total of 10 to 17 DS3 frames. The AIS integration counter is active (increments count) when an AIS signal is present, it is inactive (holds count) when an AIS signal is absent, and it is reset when an AIS signal is absent for 10 to 17 consecutive DS3 frames. An AIS condition is terminated when an AIS signal is absent for 10 to 17 consecutive DS3 frames.

A Receive Unframed All 1's (RUA1) condition is declared if in each of 4 consecutive 2047 bit windows, five or less zeros are detected and an OOF condition is continuously present. A RUA1 condition is terminated if in each of 4 consecutive 2047 bit windows, six or more zeros are detected or an OOF condition is continuously absent.

An Idle Signal (Idle) is a DS3 signal with valid F-bits, M-bits, and P-bits (P_1 and P_2). The X-bits (X_1 and X_2) are set to one, C_{31} , C_{32} , and C_{33} are set to zero, and the payload bits are set to a 1100 pattern starting with 11 immediately after each overhead bit. In C-bit mode, an Idle signal is present when a DS3 frame is received with valid F-bits, M-bits, and P-bits, both X-bits set to one, C_{31} , C_{32} , and C_{33} set to zero, and all but seven or fewer payload data bits matching the T3 overhead aligned 1100 pattern. In M23 mode, an Idle signal is present when a T3 frame is received with valid F-bits, M-bits, and P-bits, both X-bits set to one, and all but seven or fewer payload data bits matching the overhead aligned 1100 pattern. An Idle signal is absent when a DS3 frame is received that does not meet aforementioned criteria for an Idle signal being present. The Idle integration counter declares an Idle condition when it has been active for a total of 10 to 17 DS3 frames. The Idle integration counter is active (increments count) when an Idle signal is present, it is inactive (holds count) when an Idle signal is absent, and it is reset when an Idle signal is absent for 10 to 17 consecutive DS3 frames. An Idle condition is terminated when an Idle signal is absent for 10 to 17 consecutive DS3 frames.

A Remote Defect Indication (RDI) condition (also called a far-end SEF/AIS defect condition) is declared when four consecutive DS3 frames are received with the X-bits (X_1 and X_2) set to zero. An RDI condition is terminated when four consecutive DS3 frames are received with the X-bits set to one.

A DS3 Framing Format Mismatch (DS3FM) condition is declared when the DS3 format programmed (M13, C-bit) does not match the incoming DS3 signal framing format. A DS3FM condition is terminated when the incoming DS3 signal framing format is the same format as programmed. Framing errors are determined by comparing F-bits and M-bits to their expected values. The type of framing errors accumulated is programmable (OOFs, F & M, F, or M). An OOF error increments the count whenever an OOF condition is first detected. An F & M error increments the count once for each F-bit or M-bit that does not match its expected value (up to 31 per DS3 frame). An F error increments the count once for each F-bit that does not match its expected value (up to 28 per DS3 frame). An M error increments the count once for each M-bit that does not match its expected value (up to 3 per DS3 frame).

P-bit parity errors are determined by calculating the parity of the current DS3 frame (payload bits only), and comparing the calculated parity to the P-bits (P_1 and P_2) in the next DS3 frame. If the calculated parity does not match P_1 or P_2 , a single P-bit parity error is declared.

C-bit parity errors (C-bit format only) are determined by calculating the parity of the current DS3 frame (payload bits only), and comparing the calculated parity to the C-bits in subframe three (C_{31} , C_{32} , and C_{33}) in the next DS3 frame. If the calculated parity does not match C_{31} , C_{32} , or C_{33} , a single C-bit parity error is declared.

FEBE errors (C-bit format only) are determined by the C-bits in subframe four (C_{41} , C_{42} , and C_{43}). A value of 111 indicates no error and any other value indicates an error.

The receive alarm indication (RAI) bit will be set high in the transmitter when one or more of the indicated alarm conditions is present, and low when all of the indicated alarm conditions are absent. Setting the receive alarm indication on LOS, SEF, LOF, or AIS is individually programmable (on or off).

The Application Identification Channel (AIC) is stored in a register bit. It is determined from the C_{11} bit. The AIC is set to one (C-bit format) if the C_{11} bit is set to one in thirty-one consecutive multiframes. The AIC is set to zero (M23 format) if the C_{11} bit is set to zero in four of the last thirty-one consecutive multiframes. Note: The stored AIC bit must not change when an LOS, OOF, or AIS condition is present.

A FEBE is transmitted by default upon reception of a DS3 frame in which a C-bit parity error or a framing error is detected and counted.

10.6.5 C-Bit DS3 Framer/Formatter

10.6.5.1 Transmit C-bit DS3 Frame Processor

The C-bit DS3 frame format is shown in [Figure 10-14](#). [Table 10-27](#) shows the function of each overhead bit in the DS3 Frame.

Table 10-27. C-Bit DS3 Frame Overhead Bit Definitions

Bit	Definition
X_1, X_2	Remote Defect Indication (RDI)
P_1, P_2	Parity Bits
$M_1, M_2,$ and M_3	Multiframe Alignment Bits
F_{XY}	Subframe Alignment Bits
C_{11}	Application Identification Channel (AIC)
C_{12}	Reserved
C_{13}	Far-End Alarm and Control (FEAC) signal
$C_{21}, C_{22},$ and C_{23}	Unused
$C_{31}, C_{32},$ and C_{33}	C-bit parity bits
$C_{41}, C_{42},$ and C_{43}	Far-End Block Error (FEBE) bits
$C_{51}, C_{52},$ and C_{53}	Path Maintenance Data Link (or HDLC) bits
$C_{61}, C_{62},$ and C_{63}	Unused
$C_{71}, C_{72},$ and C_{73}	Unused

X_1 and X_2 are the Remote Defect Indication (RDI) bits (also referred to as the far-end SEF/AIS bits). P_1 and P_2 are the parity bits used for line error monitoring. M_1 , M_2 , and M_3 are the multiframe alignment bits. F_{XY} are the subframe alignment bits. C_{11} is the Application Identification Channel (AIC). C_{12} is reserved for future network use, and has a value of one. C_{13} is the Far-End Alarm and Control (FEAC) signal. C_{21} , C_{22} , and C_{23} are unused, and have a value of one. C_{31} , C_{32} , and C_{33} are the C-bit parity bits used for path error monitoring. C_{41} , C_{42} , and C_{43} are the Far-End Block Error (FEBE) bits used for remote path error monitoring. C_{51} , C_{52} , and C_{53} are the path maintenance data link (or HDLC) bits. C_{61} , C_{62} , and C_{63} are unused, and have a value of one. C_{71} , C_{72} , and C_{73} are unused, and have a value of one. The X-bit, P-bit, M-bit, C-bit, and F-bit positions are overhead bits, and the other bit positions in the T3 frame are payload bits regardless of how they are marked by TDEN.

10.6.5.2 Transmit C-Bit DS3 Frame Generation

C-bit DS3 frame generation receives the incoming payload data stream, and overwrites all of the overhead bit locations.

The multiframe alignment bits (M_1 , M_2 , and M_3) are overwritten with the values zero, one, and zero (010) respectively.

The subframe alignment bits (F_{X1} , F_{X2} , F_{X3} , and F_{X4}) are overwritten with the values one, zero, zero, and one (1001) respectively.

The X-bits (X_1 and X_2) are both overwritten with the Remote Defect Indicator (RDI). The RDI source is programmable (automatic, 1, or 0). If the RDI is generated automatically, the X-bits are set to zero when one or more of the indicated alarm conditions is present, and set to one when all of the indicated alarm conditions are absent. Automatically setting RDI on LOS, SEF, LOF, or AIS is individually programmable (on or off).

The P-bits (P_1 and P_2) are both overwritten with the calculated payload parity from the previous DS3 frame. The payload parity is calculated by performing modulo 2 addition of all of the payload bits after all frame processing has been completed. P-bit generation is programmable (on or off). The P-bits will be generated if either P-bit generation is enabled or frame generation is enabled.

The bits C_{11} , C_{12} , C_{21} , C_{22} , C_{23} , C_{61} , C_{62} , C_{63} , C_{71} , C_{72} , and C_{73} are all overwritten with a one.

The bit C_{13} is overwritten with the Far-End Alarm and Control (FEAC) data input from the transmit FEAC controller.

The bits C_{31} , C_{32} , and C_{33} are all overwritten with the calculated payload parity from the previous DS3 frame.

The bits C_{41} , C_{42} , and C_{43} are all overwritten with the Far-End Block Error (FEBE) bit. The FEBE bit can be generated automatically or inserted from a register bit. The FEBE bit source is programmable (automatic or register). If the FEBE bit is generated automatically, it is zero when at least one C-bit parity error has been detected during the previous frame.

The bits C_{51} , C_{52} , and C_{53} are overwritten with the path maintenance data link input from the HDLC controller.

Once all of the DS3 overhead bits have been overwritten, the data stream is passed on to error insertion. If frame generation is disabled, the incoming DS3 signal is passed on to error insertion. Frame generation is programmable (on or off). Note: P-bit generation may still be performed even if frame generation is disabled.

10.6.5.3 Transmit C-bit DS3 Error Insertion

Error insertion inserts various types of errors into the different DS3 overhead bits. The types of errors that can be inserted are framing errors, P-bit parity errors, C-bit parity errors, and Far-End Block Error (FEBE) errors.

The framing error insertion mode is programmable (F-bit, M-bit, SEF, or OOMF). An F-bit error is a single subframe alignment bit (F_{XY}) error. An M-bit error is a single multiframe alignment bit (M_1 , M_2 , or M_3) error. An SEF error is an error in all the subframe alignment bits in a subframe (F_{X1} , F_{X2} , F_{X3} , and F_{X4}). An OOMF error is a single multiframe alignment bit (M_1 , M_2 , or M_3) error in two consecutive DS3 frames.

A P-bit parity error is generated by inverting the value of the P-bits (P_1 and P_2) in a single DS3 frame. P-bit parity error(s) can be inserted one error at a time, or continuously. The P-bit parity error insertion mode (single or continuous) is programmable.

A C-bit parity error is generated by inverting the value of the C_{31} , C_{32} , and C_{33} bits in a single DS3 frame. C-bit parity error(s) can be inserted one error at a time, or continuously. The C-bit parity error insertion mode (single or continuous) is programmable.

A FEBE error is generated by forcing the C_{41} , C_{42} , and C_{43} bits in a single multiframe to zero. FEBE error(s) can be inserted one error at a time, or continuously. The FEBE error insertion rate (single or continuous) is programmable.

Each error type (framing, P-bit parity, C-bit parity, or FEBE) has a separate enable. Continuous error insertion mode inserts errors at every opportunity. Single error insertion mode inserts an error at the next opportunity when requested. The framing multi-error modes (SEF or OOMF) insert the indicated number of error(s) at the next opportunities when requested; i.e., a single request will cause multiple errors to be inserted. The requests can be initiated by a register bit (TSEI) or by the manual error insertion input (TMEI). The error insertion initiation type (register or input) is programmable. The insertion of each particular error type is individually enabled. Once all error insertion has been performed, the data stream is passed on to overhead insertion.

10.6.5.4 Transmit C-Bit DS3 Overhead Insertion

Overhead insertion can insert any (or all) of the DS3 overhead bits into the DS3 frame. The DS3 overhead bits X_1 , X_2 , P_1 , P_2 , M_X , F_{XY} , and C_{XY} can be sourced from the transmit overhead interface (TOHCLK, TOH, TOHEN, and TOHSOF). The P-bits (P_1 and P_2) and C_{31} , C_{32} , and C_{33} bits are received as an error mask (modulo 2 addition of the input bit and the internally generated bit). The DS3 overhead insertion is fully controlled by the transmit overhead interface. If the transmit overhead data enable signal (TOHEN) is driven high, then the bit on the transmit overhead signal (TOH) is inserted into the output data stream. Insertion of bits using the TOH signal overwrites internal overhead insertion.

10.6.5.5 Transmit C-Bit DS3 AIS/Idle Generation

C-bit DS3 AIS/Idle generation overwrites the data stream with AIS or an Idle signal. If transmit Idle is enabled, the data stream payload is forced to a 1100 pattern with two ones immediately following each DS3 overhead bit. M_1 , M_2 , and M_3 bits are overwritten with the values zero, one, and zero (010) respectively. F_{X1} , F_{X2} , F_{X3} , and F_{X4} bits are overwritten with the values one, zero, zero, and one (1001) respectively. X_1 and X_2 are overwritten with 11. And, P_1 , P_2 , C_{31} , C_{32} , and C_{33} are overwritten with the calculated payload parity from the previous output DS3 frame.

If transmit AIS is enabled, the data stream payload is forced to a 1010 pattern with a one immediately following each DS3 overhead bit. M_1 , M_2 , and M_3 bits are overwritten with the values zero, one, and zero (010) respectively. F_{X1} , F_{X2} , F_{X3} , and F_{X4} bits are overwritten with the values one, zero, zero, and one (1001) respectively. X_1 and X_2 are overwritten with 11. P_1 , P_2 , C_{31} , C_{32} , and C_{33} are overwritten with the calculated payload parity from the previous output DS3 frame. And, C_{X1} , C_{X2} , and C_{X3} ($X \neq 3$) are overwritten with 000. AIS will overwrite a transmit Idle signal.

10.6.5.5.1 Receive C-Bit DS3 Frame Format

The DS3 frame format is shown in [Figure 10-14](#). X_1 and X_2 are the Remote Defect Indication (RDI) bits (also referred to as the far-end SEF/AIS bits). P_1 and P_2 are the parity bits used for line error monitoring. M_1 , M_2 , and M_3 are the multiframe alignment bits that define the multiframe boundary. F_{XY} are the subframe alignment bits that define the subframe boundary. Note: Both the M-bits and F-bits define the DS3 frame boundary. C_{11} is the Application Identification Channel (AIC). C_{12} is reserved for future network use, and has a value of one. C_{13} is the Far-End Alarm and Control (FEAC) signal. C_{21} , C_{22} , and C_{23} are unused, and have a value of one. C_{31} , C_{32} , and C_{33} are the C-bit parity bits used for path error monitoring. C_{41} , C_{42} , and C_{43} are the Far-End Block Error (FEBE) bits used for remote path error monitoring. C_{51} , C_{52} , and C_{53} are the path maintenance data link (or HDLC) bits. C_{61} , C_{62} , and C_{63} are unused, and have a value of one. C_{71} , C_{72} , and C_{73} are unused, and have a value of one.

10.6.5.5.2 Receive C-Bit DS3 Overhead Extraction

Overhead extraction extracts all of the DS3 overhead bits from the C-bit DS3 frame. All of the DS3 overhead bits X_1 , X_2 , P_1 , P_2 , M_X , F_{XY} , and C_{XY} are output on the receive overhead interface (ROH, ROHSOF, and ROHCLK). The P_1 , P_2 , C_{31} , C_{32} , and C_{33} bits are output as an error indication (modulo 2 addition of the calculated parity and the bit). The C_{13} bit is sent over to the receive FEAC controller. The C_{51} , C_{52} , and C_{53} bits are sent to the receive HDLC overhead controller.

10.6.6 M23 DS3 Framer/Formatter

10.6.6.1 Transmit M23 DS3 Frame Processor

The M23 DS3 frame format is shown in [Figure 10-14](#). [Table 10-28](#) defines the framing bits for M23 DS3. X_1 and X_2 are the Remote Defect Indication (RDI) bits (also referred to as the far-end SEF/AIS bits). P_1 and P_2 are the parity bits used for line error monitoring. M_1 , M_2 , and M_3 are the multiframe alignment bits. F_{XY} are the subframe alignment bits. C_{11} is the Application Identification Channel (AIC). C_{X1} , C_{X2} , and C_{X3} are the stuff control bits for tributary #X. The X-bit, P-bit, M-bit, C-bit, and F-bit positions are overhead bits, and the remainder of the bit positions in the T3 frame are payload bits regardless of how they are marked by TDEN.

Table 10-28. M23 DS3 Frame Overhead Bit Definitions

Bit	Definition
X_1, X_2	Remote Defect Indication (RDI)
P_1, P_2	Parity Bits
$M_1, M_2, \text{ and } M_3$	Multiframe Alignment Bits
F_{XY}	Subframe Alignment Bits
C_{11}	Application Identification Channel (AIC)
$C_{X1}, C_{X2}, \text{ and } C_{X3}$	Stuff Control Bits for Tributary #X

10.6.6.2 Transmit M23 DS3 Frame Generation

M23 DS3 frame generation receives the incoming payload data stream, and overwrites all of the DS3 overhead bit locations.

The multiframe alignment bits (M_1 , M_2 , and M_3) are overwritten with the values zero, one, and zero (010) respectively.

The subframe alignment bits (F_{X1} , F_{X2} , F_{X3} , and F_{X4}) are overwritten with the values one, zero, zero, and one (1001) respectively.

The X-bits (X_1 and X_2) are both overwritten with the Remote Defect Indicator (RDI). The RDI source is programmable (automatic, 1, or 0). If the RDI is generated automatically, the X-bits are set to zero when one or more of the indicated alarm conditions is present, and set to one when all of the indicated alarm conditions are absent. Automatically setting RDI on LOS, SEF, LOF, or AIS is individually programmable (on or off).

The P-bits (P_1 and P_2) are both overwritten with the calculated payload parity from the previous DS3 frame. The payload parity is calculated by performing modulo 2 addition of all of the payload bits after all frame processing has been completed. P-bit generation is programmable (on or off). The P-bits will be generated if either P-bit generation is enabled or frame generation is enabled.

If C-bit generation is enabled, the bit C_{11} is overwritten with an alternating one zero pattern, and all of the other C-bits (C_{XY}) are overwritten with zeros. If C-bit generation is disabled, then all of the C-bit timeslots (C_{XY}) will be treated as payload data, and passed through. C-bit generation is programmable (on or off). Note: Overhead insertion may still overwrite the C-bit time slots even if C-bit generation is disabled.

Once all of the DS3 overhead bits have been overwritten, the data stream is passed on to error insertion. If frame generation is disabled, the incoming DS3 signal is passed on directly to error insertion. Frame generation is programmable (on or off). Note: P-bit generation may still be performed even if frame generation is disabled.

10.6.6.3 Transmit M23 DS3 Error Insertion

Error insertion inserts various types of errors into the different DS3 overhead bits. The types of errors that can be inserted are framing errors and P-bit parity errors.

The framing error insertion mode is programmable (F-bit, M-bit, SEF, or OOMF). An F-bit error is a single subframe alignment bit (F_{XY}) error. An M-bit error is a single multiframe alignment bit (M_1 , M_2 , or M_3) error. An SEF error is an error in all the subframe alignment bits in a subframe (F_{X1} , F_{X2} , F_{X3} , and F_{X4}). An OOMF error is a single multiframe alignment bit (M_1 , M_2 , or M_3) error in each of two consecutive DS3 frames.

A P-bit parity error is generated by inverting the value of the P-bits (P_1 and P_2) in a single DS3 frame. P-bit parity error(s) can be inserted one error at a time, or continuously. The P-bit parity error insertion mode (single or continuous) is programmable.

Each error type (framing or P-bit parity) has a separate enable. Continuous error insertion mode inserts errors at every opportunity. Single error insertion mode inserts an error at the next opportunity when requested. The framing multi-error insertion modes (SEF or OOMF) insert the indicated number of error(s) at the next opportunities when requested; i.e., a single request will cause multiple errors to be inserted. The requests can be initiated by a register bit (TSEI) or by the manual error insertion input (TMEI). The error insertion request source (register or input) is programmable. The insertion of each particular error type is individually enabled. Once all error insertion has been performed, the data stream is passed on to overhead insertion.

10.6.6.4 Transmit M23 DS3 Overhead Insertion

Overhead insertion can insert any (or all) of the DS3 overhead bits into the DS3 frame. The DS3 overhead bits X_1 , X_2 , P_1 , P_2 , M_X , F_{XY} , and C_{XY} can be sourced from the transmit overhead interface (TOHCLK, TOH, TOHEN, and TOHSOF). The P-bits (P_1 and P_2) are received as an error mask (modulo 2 addition of the input bit and the internally generated bit). The DS3 overhead insertion is fully controlled by the transmit overhead interface. If the transmit overhead data enable signal (TOHEN) is driven high, then the bit on the transmit overhead signal (TOH) is inserted into the output data stream. Insertion of bits using the TOH signal overwrites internal overhead insertion.

10.6.6.5 Transmit M23 DS3 AIS/Idle Generation

M23 DS3 AIS/Idle generation overwrites the data stream with AIS or an Idle signal. If transmit Idle is enabled, the data stream payload is forced to a 1100 pattern with two ones immediately following each DS3 overhead bit. M_1 , M_2 , and M_3 bits are overwritten with the values zero, one, and zero (010) respectively. F_{X1} , F_{X2} , F_{X3} , and F_{X4} bits are overwritten with the values one, zero, zero, and one (1001) respectively. X_1 and X_2 are overwritten with 11. P_1 and P_2 are overwritten with the calculated payload parity from the previous output DS3 frame. And, C_{31} , C_{32} , and C_{33} are overwritten with 000.

If transmit AIS is enabled, the data stream payload is forced to a 1010 pattern with a one immediately following each DS3 overhead bit. M_1 , M_2 , and M_3 bits are overwritten with the values zero, one, and zero (010) respectively. F_{X1} , F_{X2} , F_{X3} , and F_{X4} bits are overwritten with the values one, zero, zero, and one (1001) respectively. X_1 and X_2 are overwritten with 11. P_1 and P_2 are overwritten with the calculated payload parity from the previous DS3 frame. And, C_{X1} , C_{X2} , and C_{X3} are overwritten with 000. AIS will overwrite a transmit Idle signal.

10.6.6.5.1 Receive M23 DS3 Frame Format

The DS3 frame format is shown in [Figure 10-14](#). The X_1 and X_2 are the Remote Defect Indication (RDI) bits (also referred to as the far-end SEF/AIS bits). P_1 and P_2 are the parity bits used for line error monitoring. M_1 , M_2 , and M_3 are the multiframe alignment bits that define the multiframe boundary. F_{XY} are the subframe alignment bits that define the subframe boundary. Note: Both the M-bits and F-bits define the DS3 frame boundary. C_{11} is the Application Identification Channel (AIC). C_{X1} , C_{X2} , and C_{X3} are the stuff control bits for tributary #X.

10.6.6.5.2 Receive M23 DS3 Overhead Extraction

Overhead extraction extracts all of the DS3 overhead bits from the M23 DS3 frame. All of the DS3 overhead bits X_1 , X_2 , P_1 , P_2 , M_X , F_{XY} , and C_{XY} are output on the receive overhead interface (ROH, ROHSOF, and ROHCLK). The P_1 and P_2 bits are output as an error indication (modulo 2 addition of the calculated parity and the bit).

10.6.6.5.3 Receive DS3 Downstream AIS Generation

Downstream DS3 AIS (all '1's) can be automatically generated on an OOF, LOS, or AIS condition or manually inserted. If automatic downstream AIS is enabled, downstream AIS is inserted when an LOS or AIS condition is declared, or no earlier than 2.25 ms and no later than 2.75 ms after an OOF condition is declared. Automatic downstream AIS is programmable (on or off). If manual downstream AIS insertion is enabled, downstream AIS is inserted. Manual downstream AIS insertion is programmable (on or off). Downstream AIS is removed when all OOF, LOS, and AIS conditions are terminated and manual downstream AIS insertion is disabled.

10.6.7 G.751 E3 Framer/Formatter

10.6.7.1 Transmit G.751 E3 Frame Processor

The G.751 E3 frame format is shown in [Figure 10-17](#). FAS is the Frame Alignment Signal. A is the Alarm indication bit used to indicate the presence of an alarm to the remote terminal equipment. N is the National use bit reserved for national use.

Figure 10-17. G.751 E3 Frame Format

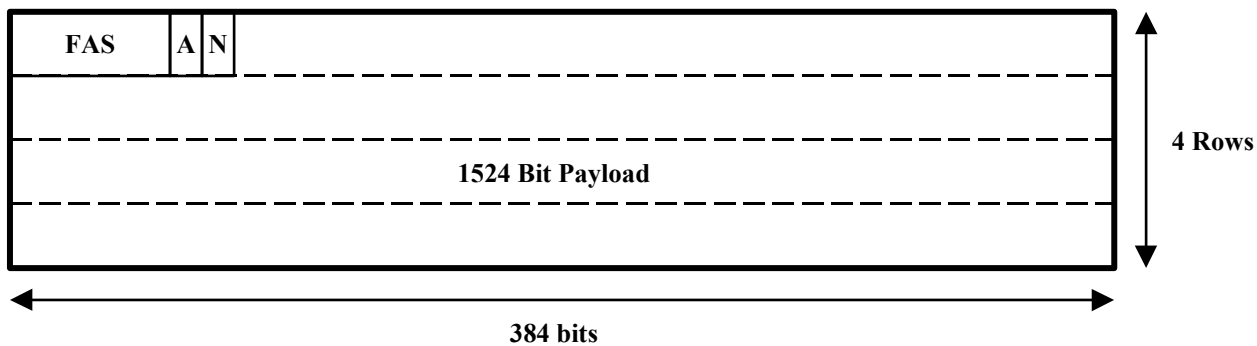

10.6.7.2 Transmit G.751 E3 Frame Generation

G.751 E3 frame generation receives the incoming payload data stream, and overwrites all of the E3 overhead bit locations.

The first ten bits of the frame are overwritten with the frame alignment signal (FAS), which has a value of 1111010000b.

The eleventh bit of the frame is overwritten with the alarm indication (A) bit. The A bit can be generated automatically, sourced from the transmit FEAC controller, set to one, or set to zero. The A bit source is programmable (automatic, FEAC, 1, or 0). If the A bit is generated automatically, it is set to one when one or more of the indicated alarm conditions is present, and set to zero when all of the indicated alarm conditions are absent. Automatically setting RDI on LOS, LOF, or AIS is individually programmable (on or off).

The twelfth bit of the frame is overwritten with the national use (N) bit. The N bit can be sourced from the transmit FEAC controller, sourced from the transmit HDLC overhead controller, set to one, or set to zero. The N bit source is programmable (FEAC, HDLC, 1, or 0). Note: The FEAC controller will source one bit per frame regardless of whether the A bit only, the N bit only, or both are programmed to be sourced from the FEAC controller.

Once all of the E3 overhead bits have been overwritten, the data stream is passed on to error insertion. If frame generation is disabled, the incoming E3 signal is passed on directly to error insertion. Frame generation is programmable (on or off).

10.6.7.3 Transmit G.751 E3 Error Insertion

Error insertion inserts framing errors into the frame alignment signal (FAS). The type of error(s) inserted into the FAS is programmable (errored FAS bit or errored FAS). An errored FAS bit is a single bit error in the FAS. An errored FAS is an error in all ten bits of the FAS (a value of 0000101111b is inserted in the FAS). Framing error(s) can be inserted one error at a time, or in four consecutive frames. The framing error insertion number (single or four) is programmable.

Single error insertion mode inserts an error at the next opportunity when requested. The multi-error insertion mode inserts the indicated number of errors at the next opportunities when requested, i.e., a single request will cause multiple errors to be inserted. The requests can be initiated by a register bit (TSEI) or by the manual error insertion input (TMEI). The error insertion initiation type (register or input) is programmable. The insertion of each particular error type is individually enabled.

Once all error insertion has been performed, the data stream is passed on to overhead insertion.

10.6.7.4 Transmit G.751 E3 Overhead Insertion

Overhead insertion can insert any (or all) of the E3 overhead bits into the E3 frame. The FAS, A bit, and N bit can be sourced from the transmit overhead interface (TOHCLK, TOH, TOHEN, and TOHSOF). The E3 overhead insertion is fully controlled by the transmit overhead interface. If the transmit overhead data enable signal (TOHEN) is driven high, then the bit on the transmit overhead signal (TOH) is inserted into the output data stream. Insertion of bits using the TOH signal overwrites internal overhead insertion.

10.6.7.5 Transmit G.751 E3 AIS Generation

G.751 E3 AIS generation overwrites the data stream with AIS. If transmit AIS is enabled, the data stream (payload and E3 overhead) is forced to all ones.

10.6.7.6 Receive G.751 E3 Frame Processor

The G.751 E3 frame format is shown in [Figure 10-17](#). FAS is the Frame Alignment Signal. A is the Alarm indication bit used to indicate the presence of an alarm to the remote terminal equipment. N is the National use bit reserved for national use.

10.6.7.6.1 Receive G.751 E3 Framing

G.751 E3 framing determines the G.751 E3 frame boundary. The frame boundary is found by identifying the frame alignment signal (FAS), which has a value of 1111010000b. The framer is an off-line framer that updates the data path frame counters when an out of frame (OOF) condition has been detected. The use of an off-line framer reduces the average time required to reframe, and reduces data loss caused by burst error. The G.751 E3 framer checks each bit position for the FAS. The frame boundary is set once the FAS is identified. Since, the FAS check is performed one bit at a time, up to 1536 checks may be needed to find the frame boundary. The data path frame counters are updated if an error free FAS is received for two additional frames, and an OOF condition is present, or if a manual frame resynchronization has been initiated.

10.6.7.6.2 Receive G.751 E3 Performance Monitoring

Performance monitoring checks the E3 frame for alarm conditions. The alarm conditions detected are OOF, LOF, COFA, LOS, AIS, RUA1, and RAI. An Out Of Frame (OOF) condition is declared when four consecutive frame alignment signals (FAS) contain one or more errors or at the next FAS check when a manual reframe is requested. An OOF condition is terminated when three consecutive FASs are error free or the G.751 E3 framer updates the data path frame counters.

A Loss Of Frame (LOF) condition is declared by the LOF integration counter when it has been active for a total of T ms. The LOF integration counter is active (increments count) when an OOF condition is present, it is inactive (holds count) when an OOF condition is absent, and it is reset when an OOF condition is absent for T continuous ms. T is programmable (0, 1, 2, or 3). An LOF condition is terminated when an OOF condition is absent for T continuous ms.

A Change Of Frame Alignment (COFA) is declared when the G.751 E3 framer updates the data path frame counters with a frame alignment that is different from the current data path frame alignment.

A Loss Of Signal (LOS) condition is declared when the HDB3 encoder is active, and it declares an LOS condition. An LOS condition is terminated when the HDB3 encoder is inactive, or it terminates an LOS condition.

An Alarm Indication Signal (AIS) condition is declared when 4 or less zeros are detected in each of two consecutive frame periods. An AIS condition is terminated when 5 or more zeros are detected in each of two consecutive frame periods.

A Receive Unframed All 1's (RUA1) condition is declared if in each of 4 consecutive 2047 bit windows, five or less zeros are detected and an OOF condition is continuously present. A RUA1 condition is terminated if in each of 4 consecutive 2047 bit windows, six or more zeros are detected or an OOF condition is continuously absent.

A Remote Alarm Indication (RAI) condition is declared when four consecutive frames are received with the A bit (first bit after the FAS) set to one. An RAI condition is terminated when four consecutive frames are received with the A bit set to zero.

Only framing errors are accumulated. Framing errors are determined by comparing the FAS to its expected value. The type of framing errors accumulated is programmable (OOFs, bit, or word). An OOF error increments the count whenever an OOF condition is first detected. A bit error increments the count once for each bit in the FAS that does not match its expected value (up to 10 per frame). A word error increments the count once for each FAS that does not match its expected value (up to 1 per frame).

The receive alarm indication (RAI) signal is high when one or more of the indicated alarm conditions is present, and low when all of the indicated alarm conditions are absent. Setting the receive alarm indication on LOS, OOF, LOF, or AIS is individually programmable (on or off).

10.6.7.6.3 Receive G.751 E3 Overhead Extraction

Overhead extraction extracts all of the E3 overhead bits from the G.751 E3 frame. The FAS, A bit, and N bit are output on the receive overhead interface (ROH, ROHSOF, and ROHCLK). In addition, the A bit is integrated and stored in a register along with a change indication, and can be output over the receive FEAC controller. The N bit is integrated and stored in a register along with a change indication, is sent to the receive HDLC overhead controller, and can also be sent to the receive FEAC controller. The bit sent to the receive FEAC controller is programmable (A or N).

10.6.7.6.4 Receive G.751 Downstream AIS Generation

Downstream G.751 E3 AIS can be automatically generated on an OOF, LOS, or AIS condition or manually inserted. If automatic downstream AIS is enabled, downstream AIS is inserted when an LOS, OOF, or AIS condition is declared. Automatic downstream AIS is programmable (on or off). If manual downstream AIS insertion is enabled, downstream AIS is inserted. Manual downstream AIS insertion is programmable (on or off). Downstream AIS is removed when all OOF, LOS, and AIS conditions are terminated and manual downstream AIS insertion is disabled. RPDT will be forced to all ones during downstream AIS.

10.6.8 G.832 E3 Framer/Formatter

10.6.8.1 Transmit G.832 E3 Frame Processor

The G.832 E3 frame format is shown in [Figure 10-18](#).

Figure 10-18. G.832 E3 Frame Format

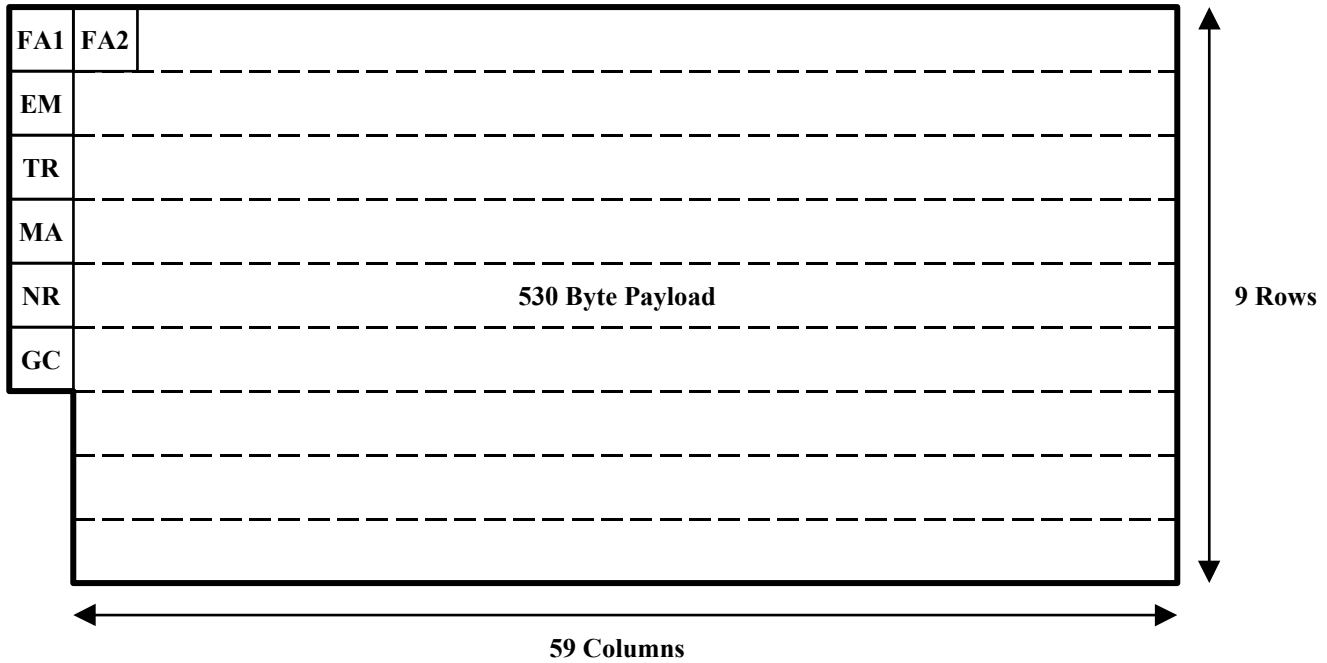
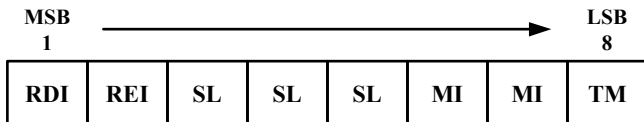

Figure 10-19. MA Byte Format



- RDI - Remote Defect Indicator
- REI - Remote Error Indicator
- SL - Signal Label
- MI - Multi-frame Indicator
- TM - Timing Marker

[Table 10-29](#) shows the function of each overhead bit in the DS3 frame.

Table 10-29. G.832 E3 Frame Overhead Bit Definitions

Byte	Definition
FA1, FA2	Frame Alignment bytes
EM	Error Monitoring byte
TR	Trail Trace byte
MA	Maintenance and Adaption byte
NR	Network Operator byte
GC	General-Purpose Communication Channel byte

FA1 and FA2 are the Frame Alignment bytes. EM is the Error Monitoring byte used for path error monitoring. TR is the Trail Trace byte used for end-to-end connectivity verification. MA is the Maintenance and Adaptation byte used for far-end path status and performance monitoring.

NR is the Network Operator byte allocated for network operator maintenance purposes. GC is the General-Purpose Communications Channel byte allocated for user communications purposes.

10.6.8.2 Transmit G.832 E3 Frame Generation

G.832 E3 frame generation receives the incoming payload data stream, and overwrites all of the E3 overhead byte locations.

The first two bytes of the first row in the frame are overwritten with the frame alignment bytes FA1 and FA2, which have a value of F6h and 28h respectively.

The first byte in the second row of the frame is overwritten with the EM byte which is a BIP-8 calculated over all of the bytes of the previous frame after all frame processing (frame generation, error insertion, overhead insertion, and AIS generation) has been performed. The first byte in the third row of the frame is overwritten with the TR byte which is input from the transmit trail trace controller.

The first byte in the fourth row of the frame is overwritten with the MA byte (see [Figure 10-19](#)), which consists of the RDI bit, REI bit, payload type, multiframe indicator, and timing source indicator.

The RDI bit can be generated automatically, set to one, or set to zero. The RDI source is programmable (automatic, 1, or 0). If the RDI is generated automatically, it is set to one when one or more of the indicated alarm conditions is present, and set to zero when all of the indicated alarm conditions are absent. Automatically setting RDI on LOS, LOF, or AIS is individually programmable (on or off).

The REI bit can be generated automatically or inserted from a register bit. The REI source is programmable (automatic or register). If REI is generated automatically, it is one when at least one parity error has been detected during the previous frame.

The payload type is sourced from a register. The three register bits are inserted in the third, fourth, and fifth bits of the MA byte in each frame.

The multiframe indicator and timing marker bits can be directly inserted from a 3-bit register or generated from a 4-bit register. The multiframe indicator and timing marker insertion type is programmable (direct or generated). When the multiframe indicator and timing marker bits are directly inserted, the three register bits are inserted in the last three bits of the MA byte in each frame. When the multiframe indicator and timing marker bits are generated, the four timing source indicator bits are transferred in a four-frame multiframe, MSB first. The multiframe indicator bits (sixth and seventh bits of the MA byte) identify the phase of the multiframe (00, 01, 10, or 11), and the timing marker bit (eighth bit of the MA byte) contains the corresponding timing source indicator bit (TMABR register bits TTI3, TTI2, TTI1, or TTI0 respectively). Note: The initial phase of the multiframe is arbitrarily chosen.

The first byte in the fifth row of the frame is overwritten with the NR byte which can be sourced from a register, from the transmit FEAC controller, or from the transmit HDLC controller. The NR byte source is programmable (register, FEAC, or HDLC). Note: The HDLC controller will source eight bits per frame period regardless of whether the NR byte only, GC byte only, or both are programmed to be sourced from the HDLC controller.

The first byte in the sixth row of the frame is overwritten with the GC byte which can be sourced from a register or from the transmit HDLC controller. The GC byte source is programmable (register or HDLC).

Once all of the E3 overhead bytes have been overwritten, the data stream is passed on to error insertion. If frame generation is disabled, the incoming E3 signal is passed on directly to error insertion. Frame generation is programmable (on or off).

10.6.8.3 Transmit G.832 E3 Error Insertion

Error insertion inserts various types of errors into the different E3 overhead bytes. The types of errors that can be inserted are framing errors, BIP-8 parity errors, and Remote Error Indication (REI) errors.

The type of framing error(s) inserted is programmable (errored frame alignment bit or errored frame alignment word). A frame alignment bit error is a single bit error in the frame alignment word (FA1 or FA2). A frame alignment word error is an error in all sixteen bits of the frame alignment word (the values 09h and D7h are inserted in the

FA1 and FA2 bytes respectively). Framing error(s) can be inserted one error at a time, or four consecutive frames. The framing error insertion mode (single or four) is programmable.

The type of BIP-8 error(s) inserted is programmable (errored BIP-8 bit, or errored BIP-8 byte). An errored BIP-8 bit is inverting a single bit error in the EM byte. An errored BIP-8 byte is inverting all eight bits in the EM byte. BIP-8 error(s) can be inserted one error at a time, or continuously. The BIP-8 error insertion mode (single or continuous) is programmable.

An REI error is generated by forcing the second bit of the MA byte to a one. REI error(s) can be inserted one error at a time, or continuously. The REI error insertion mode (single or continuous) is programmable.

Each error type (framing, BIP-8, or REI) has a separate enable. Continuous error insertion mode inserts errors at every opportunity. Single error insertion mode inserts an error at the next opportunity when requested. The framing multi-error insertion mode inserts the indicated number of errors at the next opportunities when requested. i.e., a single request will cause multiple errors to be inserted. The requests can be initiated by a register bit(TSEI) or by the manual error insertion input (TMEI). The error insertion request source (register or input) is programmable. The insertion of each particular error type is individually enabled. Once all error insertion has been performed, the data stream is passed on to overhead insertion.

10.6.8.4 Transmit G.832 E3 Overhead Insertion

Overhead insertion can insert any (or all) of the E3 overhead bytes into the E3 frame. The E3 overhead bytes FA1, FA2, EM, TR, MA, NR, and GC can be sourced from the transmit overhead interface (TOHCLK, TOH, TOHEN, and TOHSOF). The EM byte is sourced as an error mask (modulo 2 addition of the input EM byte and the generated EM byte). The E3 overhead insertion is fully controlled by the transmit overhead interface. If the transmit overhead data enable signal (TOHEN) is driven high, then the bit on the transmit overhead signal (TOH) is inserted into the output data stream. Insertion of bits using the TOH signal overwrites internal overhead insertion.

10.6.8.5 Transmit G.832 E3 AIS Generation

G.832 E3 AIS generation overwrites the data stream with AIS. If transmit AIS is enabled, the data stream (payload and E3 overhead) is forced to all ones.

10.6.8.6 Receive G.832 E3 Frame Processor

The G.832 E3 frame format is shown in [Figure 10-18](#). FA1 and FA2 are the Frame Alignment bytes. EM is the Error Monitoring byte used for path error monitoring. TR is the Trail Trace byte used for end-to-end connectivity verification. MA is the Maintenance and Adaptation byte used for far-end path status and performance monitoring (See [Figure 10-19](#)). NR is the Network Operator byte allocated for network operator maintenance purposes. GC is the General-Purpose Communications Channel byte allocated for user communications purposes.

10.6.8.7 Receive G.832 E3 Framing

G.832 E3 framing determines the G.832 E3 frame boundary. The frame boundary is found by identifying the frame alignment bytes FA1 and FA2, which have a value of F6h and 28h respectively. The framer is an off-line framer that updates the data path frame counters when an out of frame (OOF) condition has been detected. The use of an off-line framer reduces the average time required to reframe, and reduces data loss caused by burst error. The G.832 E3 framer checks each bit position for the frame alignment word (FA1 and FA2). The frame boundary is set once the frame alignment word is identified. Since, the frame alignment word check is performed one bit at a time, up to 4296 checks may be needed to find the frame boundary. The data path frame counters are updated if an error free frame alignment word is received for two additional frames, and an OOF condition is present.

10.6.8.8 Receive G.832 E3 Performance Monitoring

Performance monitoring checks the E3 frame for alarm conditions and errors. The alarm conditions detected are OOF, LOF, COFA, LOS, AIS, RUA1, and RDI. The errors accumulated are framing, parity, and Remote Error Indication (REI) errors. An Out Of Frame (OOF) condition is declared when four consecutive frame alignment words (FA1 and FA2) contain one or more errors, when 986 or more frames out of 1,000 frames has a BIP-8 block error, or at the next framing word check when a manual reframe is requested. An OOF condition is terminated when three consecutive frame alignment words (FA1 and FA2) are error free or the G.832 E3 framer updates the data path frame counters.

A Loss Of Frame (LOF) condition is declared by the LOF integration counter when it has been active for a total of T ms. The LOF integration counter is active (increments count) when an OOF condition is present, it is inactive (holds count) when an OOF condition is absent, and it is reset when an OOF condition is absent for T continuous ms. T is programmable (0, 1, 2, or 3). An LOF condition is terminated when an OOF condition is absent for T continuous ms.

A Change Of Frame Alignment (COFA) is declared when the G.832 E3 framer updates the data path frame counters with a frame alignment that is different from the current data path frame alignment.

A Loss Of Signal (LOS) condition is declared when the HDB3 encoder is active, and it declares an LOS condition. An LOS condition is terminated when the HDB3 encoder is inactive, or it terminates an LOS condition.

An Alarm Indication Signal (AIS) condition is declared when 7 or less zeros are detected in each of two consecutive frame periods that do not contain a frame alignment word. An AIS condition is terminated when 8 or more zeros are detected in each of two consecutive frame periods.

A Receive Unframed All 1's (RUA1) condition is declared if in each of 4 consecutive 2047 bit windows, five or less zeros are detected and an OOF condition is continuously present. A RUA1 condition is terminated if in each of 4 consecutive 2047 bit windows, six or more zeros are detected or an OOF condition is continuously absent.

A Remote Defect Indication (RDI) condition is declared when four consecutive frames are received with the RDI bit (first bit of MA byte) set to one. An RDI condition is terminated when four consecutive frames are received with the RDI bit set to zero.

Three types of errors are accumulated, framing, parity, and Remote Error Indication (REI) errors. Framing errors are determined by comparing FA1 and FA2 to their expected values. The type of framing errors accumulated is programmable (OOFs, bit, byte, or word). An OOF error increments the count whenever an OOF condition is first detected. A bit error increments the count once for each bit in FA1 and each bit in FA2 that does not match its expected value (up to 16 per frame). A byte error increments the count once for each FA byte (FA1 or FA2) that does not match its expected value (up to 2 per frame). A word error increments the count once for each FA word (both FA1 and FA2) that does not match its expected value (up to 1 per frame).

Parity errors are determined by calculating the BIP-8 (8-Bit Interleaved Parity) of the current E3 frame (overhead and payload bytes), and comparing the calculated BIP-8 to the EM byte in the next frame. The type of parity errors accumulated is programmable (bit or block). A bit error increments the count once for each bit in the EM byte that does not match the corresponding bit in the calculated BIP-8 (up to 8 per frame). A block error increments the count if any bit in the EM byte does not match the corresponding bit in the calculated BIP-8 (up to 1 per frame).

REI errors are determined by the REI bit (second bit of MA byte). A one indicates an error and a zero indicates no errors.

The receive alarm indication (RAI) signal is high when one or more of the indicated alarm conditions is present, and low when all of the indicated alarm conditions are absent. Setting the receive alarm indication on LOS, OOF, LOF, or AIS is individually programmable (on or off).

The receive error indication (REI) signal will transition from low to high once for each frame in which a parity error is detected.

10.6.8.9 Receive G.832 E3 Overhead Extraction

Overhead extraction extracts all of the E3 overhead bytes from the G.832 E3 frame. All of the E3 overhead bytes FA1, FA2, EM, TR, MA, NR, and GC are output on the receive overhead interface (ROH, ROHSOF, and ROHCLK).

The EM byte is output as an error indication (modulo 2 addition of the calculated BIP-8 and the EM byte).

The TR byte is sent to the receive trail trace controller.

The payload type (third, fourth, and fifth bits of the MA byte) is integrated and stored in a register with change and unstable indications. The integrated received payload type is also compared against an expected payload type. If the received and expected payload types do not match (See [Table 10-30](#)), a mismatch indication is set.

Table 10-30. Payload Label Match Status

EXPECTED	RECEIVED	STATUS
000	000	Match
000	001	Mismatch
000	XXX	Mismatch
001	000	Mismatch
001	001	Match
001	XXX	Match
XXX	000	Mismatch
XXX	001	Match
XXX	XXX	Match
XXX	YYY	Mismatch

XXX and YYY equal any value other than 000 or 001; XXX ≠ YYY

The multiframe indicator and timing marker bits (sixth, seventh, and eighth bits of the MA byte) can be integrated and stored in three register bits or extracted, integrated, and stored in four register bits. The bits (three or four) are stored with a change indication. The multiframe indicator and timing marker storage type is programmable (integrated or extracted). When the multiframe indicator and timing marker bits are integrated, the last three bits of the MA byte are integrated and stored in three register bits. When the multiframe indicator and timing marker bits are extracted, four timing source indicator bits are transferred in a four-frame multiframe, MSB first. The multiframe indicator bits (sixth and seventh bits of the MA byte) identify the phase of the multiframe (00, 01, 10, or 11). The timing marker bit (eighth bit of the MA byte) contains the timing source indicator bit indicated by the multiframe indicator bits (first, second, third, or fourth bit respectively). The four timing source indicator bits are extracted from the multiframe, integrated, and stored in four register bits with unstable and change indications.

The NR byte is integrated and stored in a register along with a change indication, it is sent to the receive FEAC controller, and it can be sent to the receive HDLC controller. The byte sent to the receive HDLC controller is programmable (NR or GC).

The GC byte is integrated and stored in a register along with a change indication, and can be sent to the receive HDLC controller. The byte sent to the receive HDLC controller is programmable (NR or GC).

10.6.8.10 Receive G.832 Downstream AIS Generation

Downstream G.832 E3 AIS can be automatically generated on an OOF, LOS, or AIS condition or manually inserted. If automatic downstream AIS is enabled, downstream AIS is inserted when an LOS, OOF, or AIS condition is declared. Automatic downstream AIS is programmable (on or off). If manual downstream AIS insertion is enabled, downstream AIS is inserted. Manual downstream AIS insertion is programmable (on or off). Downstream AIS is removed when all OOF, LOS, and AIS conditions are terminated and manual downstream AIS insertion is disabled. RPDT will be forced to all ones during downstream AIS.

10.7 HDLC Overhead Controller

10.7.1 General Description

The DS3174,3,2,1 devices contain built-in HDLC controllers (one per port) with 256 byte FIFOs for insertion/extraction of DS3 PMDL, G.751 Sn bit and G.832 NR/GC bytes.

The HDLC Overhead Controller demaps HDLC overhead packets from the DS3/E3 data stream in the receive direction and maps HDLC packets into the DS3/E3 data stream in the transmit direction.

The receive direction performs packet processing and stores the packet data in the FIFO. It removes packet data from the FIFO and outputs the packet data to the microprocessor via the register interface.

The transmit direction inputs the packet data from the microprocessor via the register interface and stores the packet data in the FIFO. It removes the packet data from the FIFO and performs packet processing.

The bits in a byte are received MSB first, LSB last. When they are output serially, they are output MSB first, LSB last. The bits in a byte in an incoming signal are numbered in the order they are received, 1 (MSB) to 8 (LSB). However, when a byte is stored in a register, the MSB is stored in the lowest numbered bit (0), and the LSB is stored in the highest numbered bit (7). This is to differentiate between a byte in a register and the corresponding byte in a signal. See [Figure 10-20](#) for the location of HDLC controllers within the DS317x devices.

Figure 10-20. HDLC Controller Block Diagram

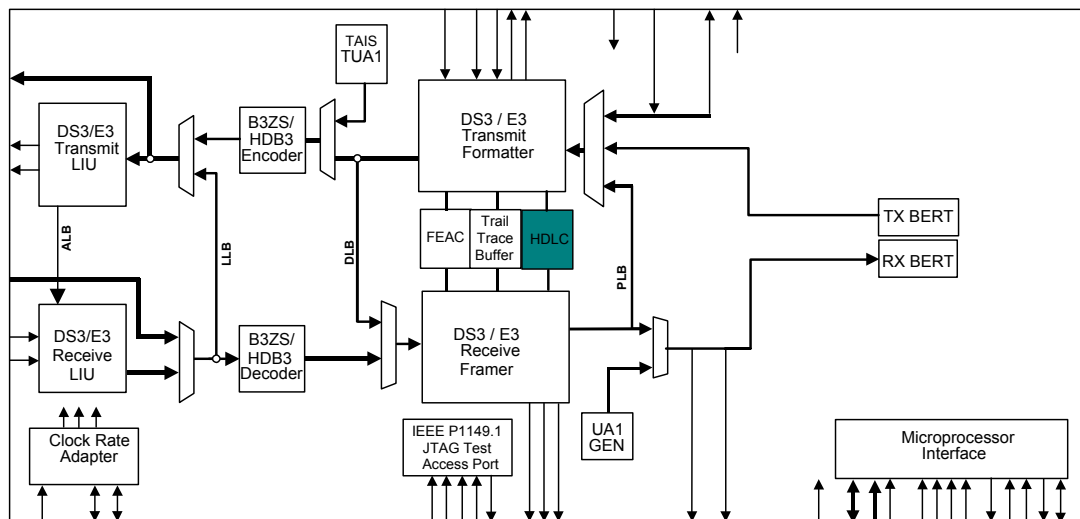

10.7.2 Features

- **Programmable inter-frame fill** – The inter-frame fill between packets can be all 1's or flags.
- **Programmable FCS generation/monitoring** – An FCS-16 can be generated and appended to the end of the packet, and the FCS can be checked and removed from the end of the packet.
- **Programmable bit reordering** – The packet data can be output MSB first or LSB first from the FIFO.
- **Programmable data inversion** – The packet data can be inverted immediately after packet processing on the transmit, and immediately before packet processing on the receive.
- **Fully independent transmit and receive paths**
- **Fully independent Line side and register interface timing** – The data storage can be read from or written to via the microprocessor interface while all line side clocks and signals are inactive, and read from or written to via the line side while all microprocessor interface clocks and signals are inactive.

10.7.3 Transmit FIFO

The Transmit FIFO block contains memory for 256 bytes of data with data status information and controller circuitry for reading and writing the memory. The Transmit FIFO controller functions include filling the memory, tracking the memory fill level, maintaining the memory read and write pointers, and detecting memory overflow and underflow conditions. The Transmit FIFO receives data and status from the microprocessor interface, and stores the data along with the data status information in memory. The Transmit Packet Processor reads the data and data status information from the Transmit FIFO. The Transmit FIFO also outputs FIFO fill status (empty/data storage available/full) via the microprocessor interface. All operations are byte based. The Transmit FIFO is considered empty when its memory does not contain any data. The Transmit FIFO is considered to have data storage available when its memory has a programmable number of bytes or more available for storage. The Transmit FIFO is considered full when it does not have any space available for storage. The Transmit FIFO accepts data from the register interface until full. If the Transmit FIFO is written to while the FIFO is full, the write is ignored, and a FIFO overflow condition is declared. The Transmit Packet Processor reads the Transmit FIFO. If the Transmit Packet Processor attempts to read the Transmit FIFO while it is empty, a FIFO underflow condition is declared.

10.7.4 Transmit HDLC Overhead Processor

The Transmit HDLC Overhead Processor accepts data from the Transmit FIFO, performs bit reordering, FCS processing, stuffing, packet abort sequence insertion, and inter-frame padding.

A byte is read from the Transmit FIFO with a packet end status. When a byte is marked with a packet end indication, the output data stream will be padded with FFh and marked with a FIFO empty indication if the Transmit FIFO contains less than two bytes or transmit packet start is disabled. Transmit packet start is programmable (on or off). When the Transmit Packet Processor reads the Transmit FIFO while it is empty, the output data stream is marked with an abort indication. Once the Transmit FIFO is empty, the output data stream will be padded with interframe fill until the Transmit FIFO contains two or more bytes of data and transmit packet start is enabled.

Bit reordering changes the bit order of each byte. If bit reordering is disabled, the outgoing 8-bit data stream DT[1:8] with DT[1] being the MSB and DT[8] being the LSB is input from the Transmit FIFO with the MSB in TFD[0] and the LSB in TFD[7] of the transmit FIFO data TFD[7:0]. If bit reordering is enabled, the outgoing 8-bit data stream DT[1:8] is input from the Transmit FIFO with the MSB in TFD[7] and the LSB in TFD[0] of the transmit FIFO data TFD[7:0]. DT[1] is the first bit transmitted on the outgoing data stream.

FCS processing calculates an FCS and appends it to the packet. FCS calculation is a CRC-16 calculation over the entire packet. The polynomial used for the CRC-16 is $x^{16} + x^{12} + x^5 + 1$. The CRC-16 is inverted after calculation, and appended to the packet. For diagnostic purposes, an FCS error can be inserted. This is accomplished by appending the calculated CRC-16 without inverting it. FCS error insertion is programmable (on or off). When FCS processing is disabled, the packet is output without appending an FCS. FCS processing is programmable (on or off).

Stuffing inserts control data into the packet to prevent packet data from mimicking flags. Stuffing is halted during FIFO empty periods. The 8-bit parallel data stream is multiplexed into a serial data stream, and bit stuffing is performed. Bit stuffing consists of inserting a '0' directly following any five contiguous '1's. Stuffing is performed from a packet start until a packet end.

Inter-frame padding inserts inter-frame fill between the packet start and end flags when the FIFO is empty. The inter-frame fill can be flags or '1's. If the inter-frame fill is flags, flags (minimum two) are inserted until a packet start is received. If the inter-frame fill is all '1's, an end flag is inserted, '1's are inserted until a packet start is received, and a start flag is inserted after the '1's. The number of '1's between the end flag and start flag may not be an integer number of bytes, however, the inter-frame fill will be at least 15 consecutive '1's. If the FIFO is not empty between a packet end and a packet start, then two flags are inserted between the packet end and packet start. The inter-frame padding type is programmable (flags or '1's).

Packet abort insertion inserts a packet abort sequences as necessary. If a packet abort indication is detected, a packet abort sequence is inserted and inter-frame padding is done until a packet start is detected. The abort sequence is FFh.

Once all packet processing has been completed, the datastream is inserted into the DS3/E3 datastream at the proper locations. If transmit data inversion is enabled, the outgoing data is inverted after packet processing is performed. Transmit data inversion is programmable (on or off).

10.7.5 Receive HDLC Overhead Processor

The Receive HDLC Overhead Packet Processor accepts data from the DS3/E3 Framer and performs packet delineation, inter-frame fill filtering, packet abort detection, destuffing, FCS processing, and bit reordering. If receive data inversion is enabled, the incoming data is inverted before packet processing is performed. Receive data inversion is programmable (on or off).

Packet delineation determines the packet boundary by identifying a packet start flag. Each time slot is checked for a flag sequence (7Eh). Once a flag is found, if it is identified as a start or end flag, and the packet boundary is set. There may be a single flag (both end and start) between packets, there may be an end flag and a start flag with a shared zero (011111101111110) between packets, there may be an end flag and a start flag (two flags) between packets, or there may be an end flag, inter-frame fill, and a start flag between packets. The flag check is performed one bit at a time.

Inter-frame fill filtering removes the inter-frame fill between a start flag and an end flag. All inter-frame fill is discarded. The inter-frame fill can be flags (01111110) or all '1's. When inter-frame fill is all '1's, the number of '1's between the end flag and the start flag may not be an integer number of bytes. When inter-frame fill is flags, the number of bits between the end flag and the start flag will be an integer number of bytes (flags). Any time there is less than 16 bits between two flags, the data will be discarded.

Packet abort detection searches for a packet abort sequence. Between a packet start flag and a packet end flag, if an abort sequence is detected, the packet is marked with an abort indication, and all subsequent data is discarded until a packet start flag is detected. The abort sequence is seven consecutive ones.

Packet abort detection searches for a packet abort sequence. Between a packet start flag and a packet end flag, if an abort sequence is detected, the packet is marked with an abort indication, and all subsequent data is discarded until a packet start flag is detected. The abort sequence is seven consecutive ones.

Destuffing removes the extra data inserted to prevent data from mimicking a flag or an abort sequence. After a start flag is detected, destuffing is performed until an end flag is detected. Destuffing consists of discarding any '0' that directly follows five contiguous '1's. After destuffing is completed, the serial bit stream is demultiplexed into an 8-bit parallel data stream and passed on with packet start, packet end, and packet abort indications. If there is less than eight bits in the last byte, an invalid packet status is set, and the packet is tagged with an abort indication. If a packet ends with five contiguous '1's, the packet will be processed as a normal packet regardless of whether or not the five contiguous '1's are followed by a '0'.

FCS processing checks the FCS, discards the FCS bytes, and marks FCS erred packets. The FCS is checked for errors, and the last two bytes are removed from the end of the packet. If an FCS error is detected, the packet is marked with an FCS error indication. The HDLC CONTROLLER performs FCS-16 checking. FCS processing is programmable (on or off). If FCS processing is disabled, FCS checking is not performed, and all of the packet data is passed on.

Bit reordering changes the bit order of each byte. If bit reordering is disabled, the incoming 8-bit data stream DT[1:8] with DT[1] being the MSB and DT[8] being the LSB is output to the Receive FIFO with the MSB in RFD[0] and the LSB in RFD[7] of the receive FIFO data RFD[7:0]. If bit reordering is enabled, the incoming 8-bit data stream DT[1:8] is output to the Receive FIFO with the MSB in RFD[7] and the LSB in RFD[0] of the receive FIFO data RFD[7:0]. DT[1] is the first bit received from the incoming data stream.

Once all of the packet processing has been completed, The 8-bit parallel data stream is passed on to the Receive FIFO with packet start, packet end, and packet error indications.

10.7.6 Receive FIFO

The Receive FIFO block contains memory for 256 bytes of data with data status information and controller circuitry for reading and writing the memory. The Receive FIFO Controller controls filling the memory, tracking the memory fill level, maintaining the memory read and write pointers, and detecting memory overflow and underflow conditions. The Receive FIFO accepts data and data status from the Receive Packet Processor and stores the data along with data status information in memory. The data is read from the receive FIFO via the microprocessor interface. The Receive FIFO also outputs FIFO fill status (empty/data available/full) via the microprocessor interface. All operations are byte based. The Receive FIFO is considered empty when it does not contain any data. The Receive FIFO is considered to have data available when there is a programmable number of bytes or more stored in the memory. The Receive FIFO is considered full when it does not have any space available for storage.

The Receive FIFO accepts data from the Receive Packet Processor until full. If a packet start is received while full, the data is discarded and a FIFO overflow condition is declared. If any other packet data is received while full, the current packet being transferred is marked with an abort indication, and a FIFO overflow condition is declared. Once a FIFO overflow condition is declared, the Receive FIFO will discard incoming data until a packet start is received while the Receive FIFO has sixteen or more bytes available for storage. If the Receive FIFO is read while the FIFO is empty, the read is ignored, and an invalid data indication given.

10.8 Trail Trace Controller

10.8.1 General Description

Each port has a dedicated Trail Trace Buffer for E3-G.832 link management

The Trail Trace Controller performs extraction and storage of the incoming G.832 trail access point identifier in a 16-byte receive register.

The Trail Trace Controller extracts/inserts E3-G.832 trail access point identifiers using a 16-byte register(one for transmit, one for receive).

The Trail Trace Controller demaps a 16-byte trail trace identifier from the E3-G.832 TR Byte of the overhead in the receive direction and maps a trace identifier into the E3-G.832 datastream in the transmit direction.

The receive direction inputs the trace ID data stream, performs trace ID processing, and stores the trace identifier data in the data storage using line timing. It removes trace identifier data from the data storage and outputs the trace identifier data to the microprocessor via the microprocessor interface using register timing. The data is forced to all ones during LOS, LOF and AIS detection to eliminate false messages

The transmit direction inputs the trace identifier data from the microprocessor via the microprocessor interface and stores the trace identifier data in the data storage using register timing. It removes the trace identifier data from the data storage, performs trace ID processing, and outputs the trace ID data stream. Refer to [Figure 10-21](#) for the location of the Trail Trace Controller with the DS317x devices.

Figure 10-21. Trail Trace Controller Block Diagram

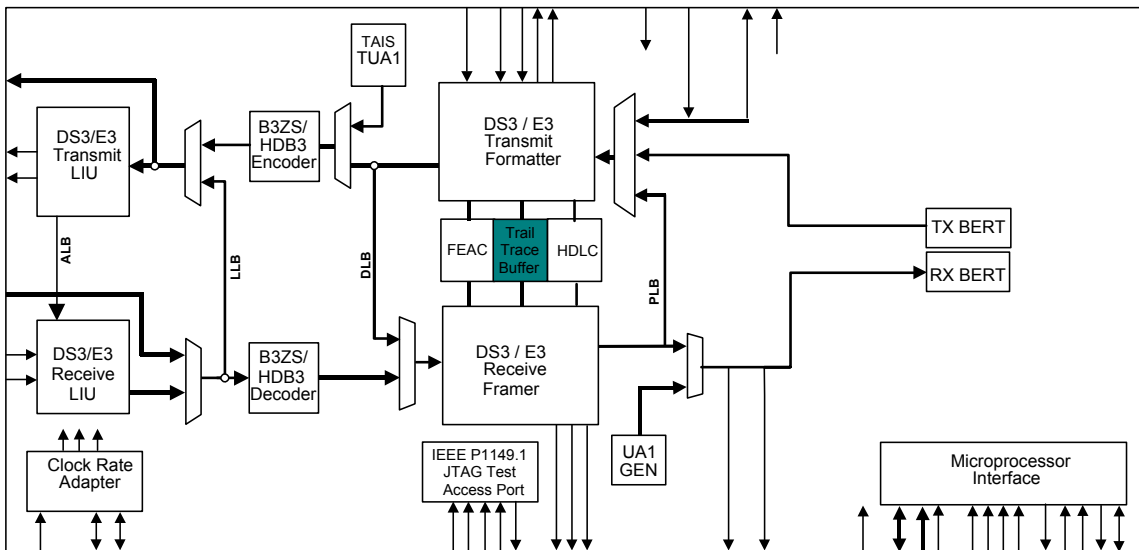

10.8.2 Features

- **Programmable trail trace ID** – The trail trace ID controller can be programmed to handle a 16-byte trail trace identifier (trail trace mode).
- **Programmable transmit trace ID** – All sixteen bytes of the transmit trail trace identifier are programmable.
- **Programmable receive expected trace ID** – A 16-byte expected trail trace identifier can be programmed. Both a mismatch and unstable indication are provided.

- **Programmable trace ID multi-frame alignment** – The transmit side can be programmed to perform trail trace multi-frame alignment insertion. The receive side can be programmed to perform trail trace multi-frame synchronization.
- **Programmable bit reordering** – The trace identifier data can be output MSB first or LSB first from the data storage.
- **Programmable data inversion** – The trace identifier data can be inverted immediately after trace ID processing on the transmit side, and immediately before trail ID processing on the receive side.
- **Fully independent transmit and receive sides**
- **Fully independent Line side and register interface timing** – The data storage can be read from or written to via the microprocessor interface while all line side clocks and signals are inactive, and read from or written to via the line side while all microprocessor interface clocks and signals are inactive.

10.8.3 Functional Description

The bits in a byte are received most significant bit (MSB) first and least significant bit (LSB) last. When they are output serially, they are output MSB first and LSB last. The bits in a byte in an incoming signal are numbered in the order they are received, 1 (MSB) to 8 (LSB). However, when a byte is stored in a register, the MSB is stored in the highest numbered bit (7), and the LSB is stored in the lowest numbered bit (0). This is to differentiate between a byte in a register and the corresponding byte in a signal.

10.8.4 Transmit Data Storage

The Transmit Data Storage block contains memory for 16 bytes of data and controller circuitry for reading and writing the memory. The Transmit Data Storage controller functions include filling the memory and maintaining the memory read and write pointers. The Transmit Data Storage receives data from the microprocessor interface, and stores the data in memory. The Transmit Trace ID Processor reads the data from the Transmit Data Storage. The Transmit Data Storage contains the transmit trail trace identifier. Note: The contents of the transmit trail (path) trace identifier memory will be random data immediately after power-up, and will not change during a reset (\overline{RST} or \overline{DRST} low).

10.8.5 Transmit Trace ID Processor

The Transmit Trace ID Processor accepts data from Transmit Data Storage, processes the data according to the Transmit Trace ID mode, and outputs the serial trace ID data stream.

10.8.6 Transmit Trail Trace Processing

The Transmit Trail Trace Processing accepts data from the Transmit Data Storage performs bit reordering and multi-frame alignment insertion.

Bit reordering changes the bit order of each byte. If bit reordering is disabled, the outgoing 8-bit data stream DT[1:8] with DT[1] being the MSB and DT[8] being the LSB is input from the Transmit Data Storage with the MSB in TTD[7] and the LSB in TTD[0] of the transmit trace ID data TTD[7:0]. If bit reordering is enabled, the outgoing 8-bit data stream DT[1:8] is input from the Transmit Data Storage with the MSB is in TTD[0] and the LSB is in TTD[7] of the transmit trace ID data TTD[7:0]. DT[1] is the first bit transmitted on the outgoing data stream.

Multi-frame alignment insertion overwrites the MSB of each trail trace byte with the multi-frame alignment signal. The MSB of the first byte in the trail trace identifier is overwritten with a one, the MSB of the other fifteen bytes in the trail trace identifier are overwritten with a zero. Multi-frame alignment insertion is programmable (on or off).

If transmit data inversion is enabled, the outgoing data is inverted after trail trace processing is performed. Transmit data inversion is programmable (on or off). If transmit trail trace identifier idle (Idle) is enabled, the trail trace data is overwritten with all zeros. Transmit Idle is programmable (on or off).

10.8.7 Receive Trace ID Processor

The Receive Trace ID Processor receives the incoming serial trace ID data stream and processes the incoming data according to the Receive Trace ID mode, and passes the trace ID data on to Receive Data Storage.

The bits in a byte are received MSB first, LSB last. The bits in a byte in an incoming signal are numbered in the order they are received, 1 (MSB) to 8 (LSB). However, when a byte is stored in a register, the MSB is stored in the

highest numbered bit (7), and the LSB is stored in the lowest numbered bit (0). This is to differentiate between a byte in a register and the corresponding byte in a signal.

10.8.8 Receive Trail Trace Processing

The Receive Trail Trace Processing accepts an incoming data line and performs trail trace alignment, trail trace extraction, expected trail trace comparison, and bit reordering. If receive data inversion is enabled, the incoming data is inverted before trail trace processing is performed. Receive data inversion is programmable (on or off).

Trail trace alignment determines the trail trace identifier boundary by identifying the multi-frame alignment signal. The multi-frame alignment signal (MAS) is located in the MSB of each byte (see [Figure 10-22](#)). The MAS bits are each checked for the multi-frame alignment start bit, which is a one. Once a multi-frame alignment start bit is found, the remaining fifteen bits of the MAS are verified as being zero. The MAS check is performed one byte at a time. Multi-frame alignment is programmable (on or off). When multi-frame alignment is disabled, the incoming bytes are sequentially stored starting with a random byte.

Figure 10-22. Trail Trace Byte (DT = Trail Trace Data)

Bit 1 MSB	Bit 2	Bit 3	Bit 4	Bit 5	Bit 6	Bit 7	Bit 8 LSB
MAS or DT[1]	DT[2]	DT[3]	DT[4]	DT[5]	DT[6]	DT[7]	DT[8]

Trail trace extraction extracts the trail trace identifier from the incoming trail trace data stream, generates a trail trace identifier change indication, detects a trail trace identifier idle (Idle) condition, and detects a trail trace identifier unstable (TIU) condition. The trail trace identifier bytes are stored sequentially with the first byte (MAS equals 1 if trail trace alignment is enabled) being stored in the first byte of memory. If the exact same non-zero trail trace identifier is received five consecutive times and it is different from the receive trail trace identifier, a receive trail trace identifier update is performed, and the receive trail trace identifier change indication is set.

An Idle condition is declared when an all zeros trail trace identifier is received five consecutive times. An Idle condition is terminated when a non-zero trail trace identifier is received five consecutive times or a TIU condition is declared. A TIU condition is declared if eight consecutive trail trace identifiers are received that do not match either the receive trail trace identifier or the previously stored current trail trace identifier. The TIU condition is terminated when a non-zero trail trace identifier is received five consecutive times or an Idle condition is declared.

Expected trail trace comparison compares the received and expected trail trace identifiers. The comparison is a 7-bit comparison of the seven least significant bits (DT[2:8] (see [Figure 10-22](#)) of each trail trace identifier byte (The multi-frame alignment signal is ignored). If the received and expected trail trace identifiers do not match, a trail trace identifier mismatch (TIM) condition is declared. If they do match the TIM condition is terminated. The 16-byte expected trail trace identifier is programmable. Expected trail trace comparison is programmable (on or off). If multi-frame alignment is disabled, expected trail trace comparison is disabled. Immediately after a reset, the receive trail trace identifier is invalid. All comparisons between the receive trail trace identifier and expected trail trace identifier will match (a TIM condition cannot occur) until after the first receive trail trace identifier update occurs.

Bit reordering changes the bit order of each byte. If bit reordering is disabled, the incoming 8-bit data stream DT[1:8] with DT[1] being the MSB and DT[8] being the LSB is output to the Receive Data Storage with the MSB in RTD[7] and the LSB in RTD[0] of the receive trace ID data RTD[7:0]. If bit reordering is enabled, the incoming 8-bit data stream DT[1:8] is output to the Receive Data Storage with the MSB in RTD[0] and the LSB in RTD[7] of the receive trace ID data RTD[7:0]. DT[1] is the first bit received from the incoming data stream.

Once all of the trail trace processing has been completed, The 8-bit parallel data stream is passed on to the Receive Data Storage.

10.8.9 Receive Data Storage

The Receive Data Storage block contains memory for 48 bytes of data, maintains data status information, and has controller circuitry for reading and writing the memory. The Receive Data Storage controller functions include filling

the memory and maintaining the memory read and write pointers. The Receive Data Storage accepts data and data status from the Receive Trace ID Processor, stores the data in memory, and maintains data status information. The data is read from the Receive Data Storage via the microprocessor interface. The Receive Data Storage contains the current trail trace identifier, the receive trail trace identifier, and the expected trail trace identifier.

10.9 FEAC Controller

10.9.1 General Description

The FEAC Controller demaps FEAC codewords from a DS3/E3 data stream in the receive direction and maps FEAC codewords into a DS3/E3 data stream in the transmit direction. The transmit direction demaps FEAC codewords from a DS3/E3 data stream.

The receive direction performs FEAC processing, and stores the codewords in the FIFO using line timing. It removes the codewords from the FIFO and outputs them to the microprocessor via the register interface.

The transmit direction inputs codewords from the microprocessor via the register interface and stores the codewords. It removes the codewords and performs FEAC processing. See [Figure 10-23](#) for the location of the FEAC Controller in the block diagram

Figure 10-23. FEAC Controller Block Diagram

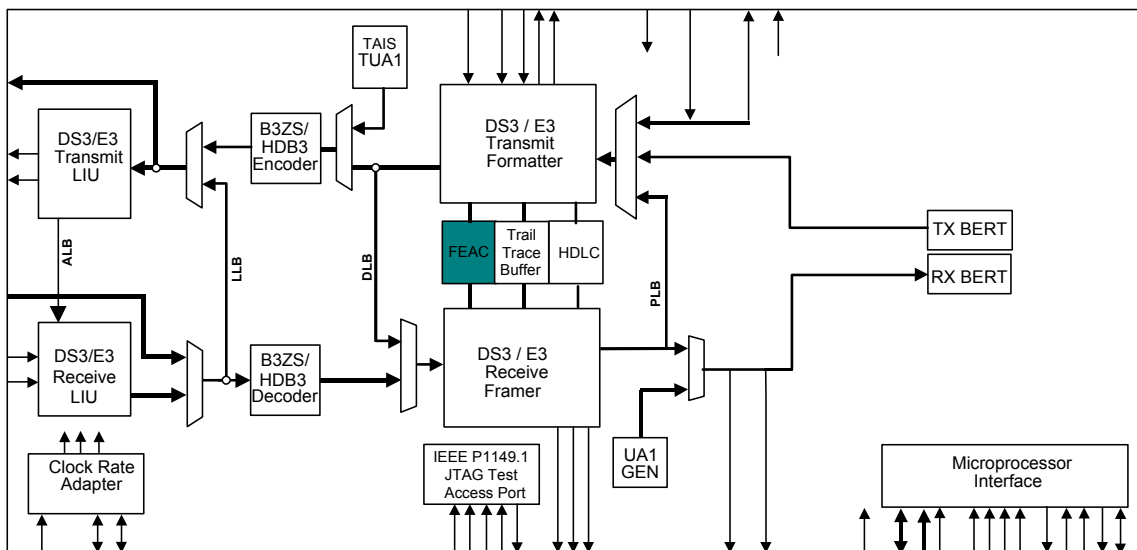

10.9.2 Features

- **Programmable dual codeword output** – The transmit side can be programmed to output a single codeword ten times, one codeword ten times followed by a second codeword ten times, or a single codeword continuously.
- **Four codeword receive FIFO**
- **Fully independent transmit and receive paths**
- **Fully independent Line side and register side timing** – The FIFO can be read from or written to at the register interface side while all line side clocks and signals are inactive, and read from or written to at the line side while all register interface side clocks and signals are inactive.

10.9.3 Functional Description

The bits in a code are received MSB first, LSB last. When they are output serially, they are output MSB first, LSB last. The bits in a code in an incoming signal are numbered in the order they are received, 1 (MSB) to 6 (LSB). However, when a code is stored in a register, the MSB is stored in the lowest numbered bit (0), and the LSB is

stored in the highest numbered bit (5). This is to differentiate between a code in a register and the corresponding code in a signal.

10.9.3.1 Transmit Data Storage

The Transmit Data Storage block contains the registers for two FEAC codes (C{1:6}) and controller circuitry for reading and writing the memory. The Transmit Data Storage receives data from the microprocessor interface, and stores the data in memory. The Transmit FEAC Processor reads the data from the Transmit Data Storage.

10.9.3.2 Transmit FEAC Processor

The Transmit FEAC Processor accepts data from the Transmit Data Storage performs FEAC processing. The FEAC codes are read from Transmit Data Storage with the MSB (C[1]) in TFCA[0] or TFCB[0], and the LSB (C[6]) in TFCA[5] or TFCB[5].

FEAC processing has four modes of operation (Idle, single code, dual code, and continuous code). In Idle mode, all ones are output on the outgoing FEAC data stream. In single code mode, the code from TFCA[5:0] is inserted into a codeword (See [Figure 10-24](#)), and sent ten consecutive times. Once the ten codewords have been sent, all ones are output. In dual code mode, the code from TFCA[5:0] is inserted into a codeword, and sent ten consecutive times. Then the code from TFCB[5:0] is inserted into a codeword, and sent ten consecutive times. Once both codewords have both been sent ten times, all ones are output. In continuous mode, the code from TFCA[5:0] is inserted into a codeword, and sent until the mode is changed

10.9.3.3 Receive FEAC Processor

The Receive FEAC Processor accepts an incoming data line and extracts all overhead and performs FEAC code extraction, and Idle detection.

Figure 10-24. FEAC Codeword Format

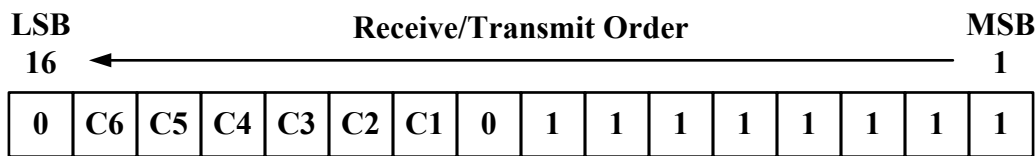

Cx - FEAC Code

FEAC code extraction determines the codeword boundary by identifying the codeword sequence and extracts the FEAC code. A FEAC codeword is a repeating 16-bit pattern (See [Figure 10-24](#)). The codeword sequence is the pattern (0xxxxx01111111) that contains each FEAC code (C[6:1]). Each time slot is checked for a codeword sequence. Once a codeword sequence is found, the FEAC code is checked. If the same FEAC code is received in three consecutive codewords without errors, the FEAC code detection indication is set, and the FEAC code is stored in the Receive FIFO with the MSB (C[1]) in RFF[0], and the LSB (C[6]) in RFF[5]. The FEAC code detection indication is cleared if two consecutively received FEAC codewords differ from the current FEAC codeword, or a FEAC Idle condition is detected.

Idle detection detects a FEAC Idle condition. A FEAC idle condition is declared if sixteen consecutive ones are received. The FEAC Idle condition is terminated when the FEAC code detection indication is set.

10.9.3.4 Receive FEAC FIFO

The Receive FIFO block contains memory for four FEAC codes (C[1:6]) and controller circuitry for reading and writing the memory. The Receive FIFO controller functions include filling the memory, tracking the memory fill level, maintaining the memory read and write pointers, and detecting memory overflow and underflow conditions. The Receive FIFO accepts data from the Receive FEAC Processor and stores the data in memory. The data is read from the receive FIFO via the microprocessor interface. The Receive FIFO also outputs FIFO fill status (empty) via the microprocessor interface. All operations are code based (six bits). The Receive FIFO is considered empty when it does not contain any data. The Receive FIFO accepts data from the Receive FEAC Processor until full. If a FEAC code is received while full, the data is discarded and a FIFO overflow condition is declared. If the Receive FIFO is read while the FIFO is empty, the read is ignored.

10.10 Line Encoder/Decoder

10.10.1 General Description

The B3ZS/HDB3 Decoder converts a bipolar signal to a unipolar signal in the receive direction. B3ZS/HDB3 Encoder converts a unipolar signal to a bipolar signal in the transmit direction.

In the transmit direction, the Encoder converts the unipolar signal to a bipolar signal, optionally performing zero suppression encoding (HDB3/B3ZS), optionally inserting errors, and outputs the bipolar signal.

In the receive direction, the Decoder receives a bipolar signal, monitors it for alarms and errors, optionally performing zero suppression decoding (HDB3/B3ZS), and converts it to a unipolar signal.

If the port line interface is configured for a Unipolar mode, the BPV detector will count pulses on the RLCVn pin. See [Figure 10-25](#) for the locations of the Line Encoder/ Decoder block in the DS317x devices.

Figure 10-25. Line Encoder/Decoder Block Diagram

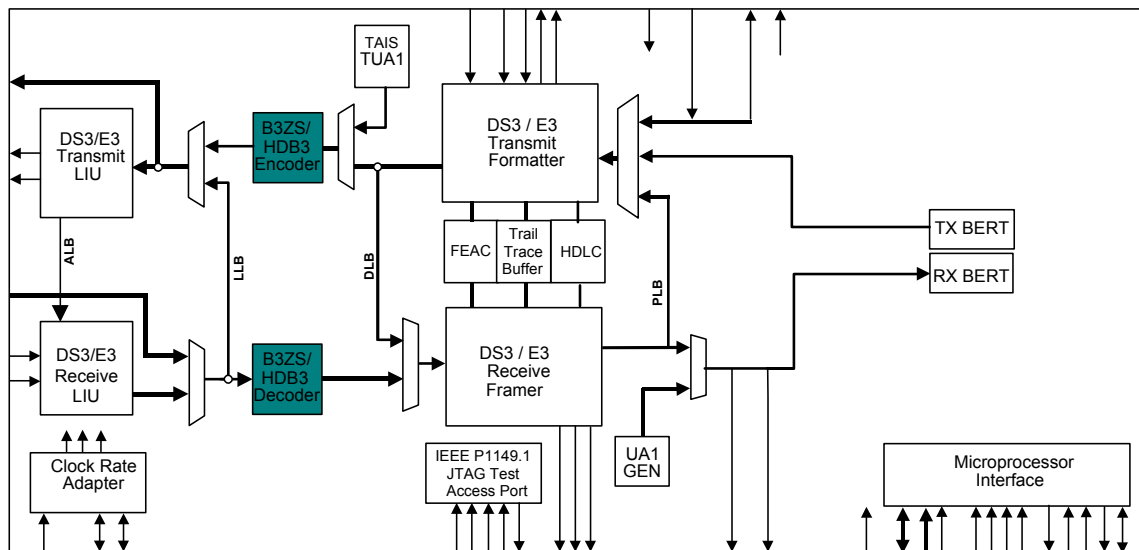

10.10.2 Features

- **Performs bipolar to unipolar encoding and decoding** – Converts a unipolar signal into an AMI bipolar signal (POS data, and NEG data) and vice versa.
- **Programmable zero suppression** – B3ZS or HDB3 zero suppression encoding and decoding can be performed, or the bipolar data stream can be left as an AMI encoded data stream.
- **Programmable receive zero suppression code format** – The signature of B3ZS or HDB3 is selectable.
- **Generates and detects alarms and errors** – In the receive direction, detects LOS alarm condition BPV errors, and EXZ errors. In the transmit direction, errors can be inserted into the outgoing data stream.

10.10.3 B3ZS/HDB3 Encoder

B3ZS/HDB3 Encoder performs unipolar to bipolar conversion and zero suppression encoding.

Unipolar to bipolar conversion converts the unipolar data stream into an AMI bipolar data stream (POS and NEG). In an AMI bipolar data stream a zero is represented by a zero on both the POS and NEG signals, and a one is represented by a one on a bipolar signal (POS or NEG), and a zero on the other bipolar signal (NEG or POS). Successive ones are represented by ones that are alternately output on the POS and NEG signals. i.e., if a one is represented by a one on POS and a zero on NEG, the next one will be represented by a one on NEG and a zero on POS.

Zero suppression encoding converts an AMI bipolar data stream into a B3ZS or HDB3 encoded bipolar data stream. A B3ZS encoded bipolar signal is generated by inserting a B3ZS signature into the bipolar data stream if both the POS and NEG signals are zero for three consecutive clock periods. An HDB3 encoded bipolar signal is

generated by inserting an HDB3 signature into the bipolar data stream if both the POS and NEG signals are zero for four consecutive clock periods. Zero suppression encoding can be disabled which will result in AMI-coded data.

Error insertion is also performed. Error insertion inserts bipolar violation (BPV) or excessive zero (EXZ) errors onto the bipolar signal. A BPV error will be inserted when three consecutive ones occur. An EXZ error will be inserted when three (or four) consecutive zeros on the bipolar signal occur by inhibiting the insertion of a B3ZS (HDB3) signature. There will be at least one intervening pulse between consecutive BPV or EXZ errors. A single BPV or EXZ error inserted will be detected as a single BPV/EXZ error at the far-end, and will not cause any other type of error to be detected. For example, if a BPV error is inserted, the far-end should not also detect a data error.

10.10.4 Transmit Line Interface

The Transmit Line Interface accepts a bipolar data stream from the B3ZS/HDB3 Encoder, performs error insertion, and transmits the bipolar data stream.

Error insertion inserts BPV or EXZ errors into the bipolar signal. When a BPV error is to be inserted, the Transmit Line Interface waits for the next occurrence of three consecutive ones. The first bipolar one is generated according to the normal AMI rules. The second bipolar one is generated by transmitting the same values on TPOS and TNEG as the values for the first one. The third bipolar one is generated according to the normal AMI rules. When an EXZ error is to be inserted, the Transmit Line Interface waits for the next occurrence of three (four) consecutive zeros on the bipolar signal, and inhibits the insertion of a B3ZS (HDB3) signature. There must be at least one intervening one between consecutive BPV or EXZ errors. A single BPV or EXZ error inserted must be detected as a single BPV/EXZ error at the far-end, and not cause any other type of error to be detected. For example, if a BPV error is inserted, the far-end should not also detect a data error. If a second error insertion request of a given type (BPV or EXZ) is initiated before a previous request has been completed, the second request will be ignored.

The outgoing bipolar data stream consists of positive pulse data (TPOS_n) and negative pulse data (TNEG_n). TPOS_n and TNEG_n are updated on the rising edge of TLCLK_n.

10.10.5 Receive Line Interface

The Receive Line Interface receives a bipolar signal. The incoming bipolar data line consists of positive pulse data (RPOS_n), negative pulse data (RNEG_n), and clock (RLCLK_n) signals. RPOS_n and RNEG_n are sampled on the rising edge of RLCLK_n. The incoming bipolar signal is checked for a Loss Of Signal (LOS) condition, and passed on to B3ZS/HDB3 Decoder. An LOS condition is declared if both RPOS_n and RNEG_n do not have any transitions for 192 clock cycles. The LOS condition is terminated after 192 clock cycles without any EXZ errors. Note: When zero suppression (B3ZS or HDB3) decoding is disabled, the LOS condition is cleared, and cannot be detected.

10.10.6 B3ZS/HDB3 Decoder

The B3ZS/HDB3 Decoder receives a bipolar signal from the LIU (or the RPOS/RNEG pins). The incoming bipolar signal is checked for a Loss of Signal (LOS) condition. An LOS condition is declared if both the positive pulse data and negative pulse data signals do not have any transitions for 192 clock cycles. The LOS condition is terminated after 192 clock cycles without any EXZ errors.

B3ZS/HDB3 Decoder performs EXZ detection, zero suppression decoding, BPV detection, and bipolar to unipolar conversion.

EXZ detection checks the bipolar data stream for excessive zeros (EXZ) errors. In B3ZS mode, an EXZ error is declared whenever there is an occurrence of 3 or more zeros. In HDB3 mode, an EXZ error is declared whenever there is an occurrence of 4 or more zeros. EXZ errors are accumulated in the EXZ counter (*LINE.REXZCR* register).

Zero suppression decoding converts B3ZS or HDB3 encoded bipolar data into an AMI bipolar signal. In B3ZS mode, the encoded bipolar signal is checked for a B3ZS signature. If a B3ZS signature is found, it is replaced with three zeros. In HDB3 mode, the encoded bipolar signal is checked for an HDB3 signature. If an HDB3 signature is found, it is replaced with four zeros. The format of both an HDB3 signature and a B3ZS signature is programmable. When [LINE.RCR.REZSF](#) = 0, the decoder will search for a zero followed by a BPV in B3ZS mode, and in HDB3 mode it will search for two zeros followed by a BPV. If [LINE.RCR.REZSF](#) = 1, the same criteria is applied with an additional requirement that the BPV must be the opposite polarity of the previous BPV. See [Figure 10-26](#) and [Figure 10-27](#). Zero suppression decoding is also programmable (on or off). Note: Immediately after a reset or a

LOS condition, the first B3ZS/HDB3 signature to be detected will not depend upon the polarity of any BPV contained within the signature.

Figure 10-26. B3ZS Signatures

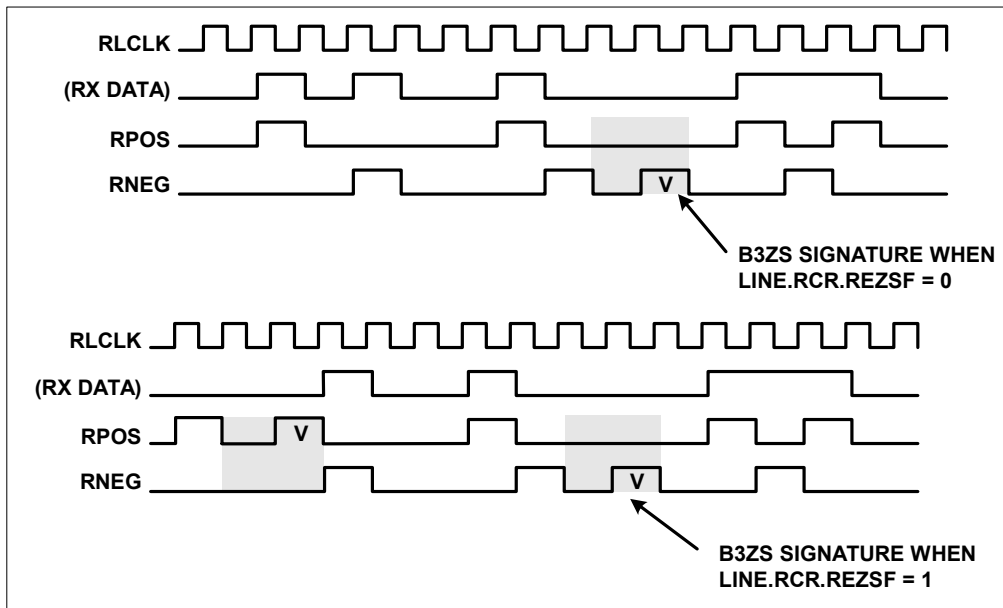
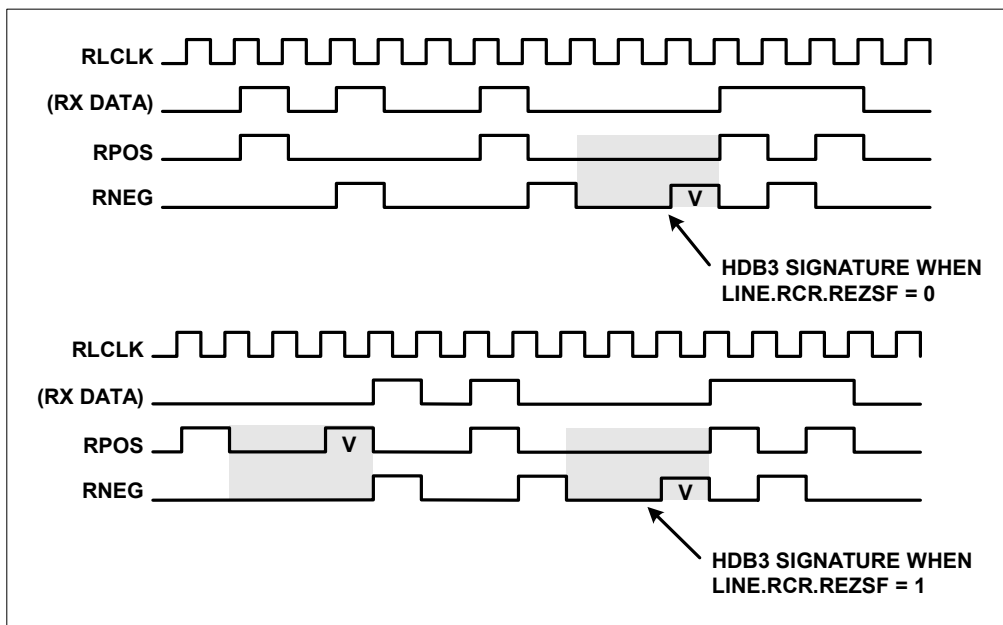

Figure 10-27. HDB3 Signatures



BPV detection checks the bipolar signal for bipolar violation (BPV) errors and E3 code violation (CV) errors. A BPV error is declared if two 1's are detected on RXP or RXN without an intervening 1 on RXN or RXP, and the 1's are not part of a B3ZS/HDB3 signature, or when both RXP and RXN are a one. An E3 coding violation is declared if consecutive BPVs of the same polarity are detected (ITU O.161 definition). E3 CVs are accumulated in the BPV counter (*LINE.RBPVCR* register) if E3 CV detection has been enabled (applicable only in HDB3 mode), otherwise, BPVs are accumulated in the BPV counter. If zero code suppression is disabled, the BPV counter will count all bipolar violations. The BPV counter will count pulses on the RLCVn pin when the device is configured for unipolar mode.

Immediately after a reset (or datapath reset) or a LOS condition, a BPV will not be declared when the first valid one (RPOS high and RNEG low, or RPOS low and RNEG high) is received. Bipolar to unipolar conversion converts the AMI bipolar data into a unipolar signal by ORing together the RXP and RXN signals.

10.11 BERT

10.11.1 General Description

The BERT is a software programmable test pattern generator and monitor capable of meeting most error performance requirements for digital transmission equipment. It will generate and synchronize to pseudo-random patterns with a generation polynomial of the form $x^n + x^y + 1$, where n and y can take on values from 1 to 32 and to repetitive patterns of any length up to 32 bits.

The transmit direction generates the programmable test pattern, and inserts the test pattern payload into the data stream.

The receive direction extracts the test pattern payload from the receive data stream, and monitors the test pattern payload for the programmable test pattern. See [Figure 10-28](#) for the location of the BERT Block within the DS3174x devices.

Figure 10-28. BERT Block Diagram

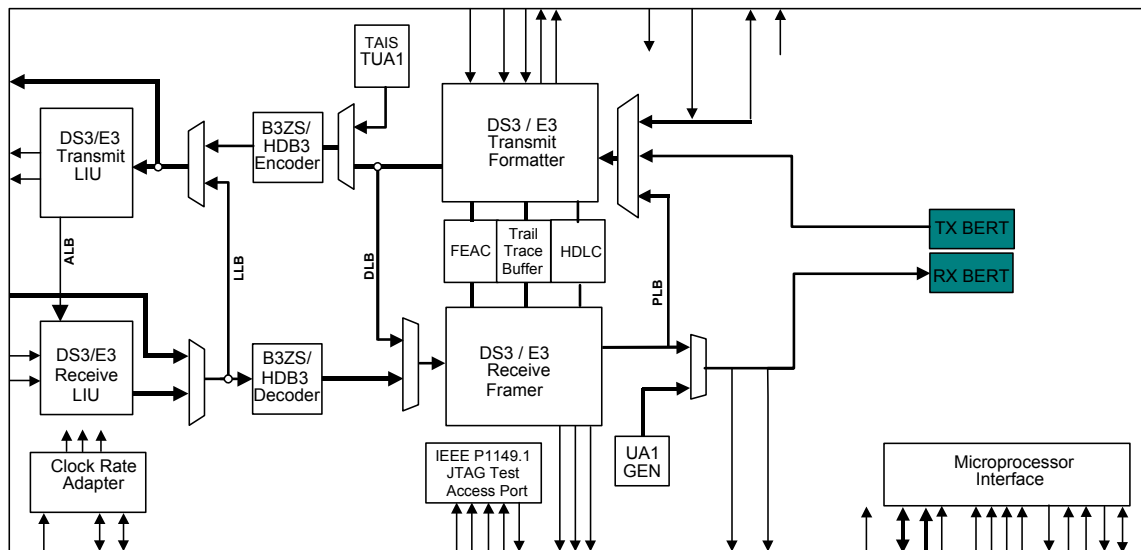

10.11.2 Features

- **Programmable PRBS pattern** – The Pseudo Random Bit Sequence (PRBS) polynomial ($x^n + x^y + 1$) and seed are programmable (length $n = 1$ to 32, tap $y = 1$ to $n - 1$, and seed = 0 to $2^n - 1$).
- **Programmable repetitive pattern** – The repetitive pattern length and pattern are programmable (the length $n = 1$ to 32 and pattern = 0 to $2^n - 1$).
- **24-bit error count and 32-bit bit count registers**
- **Programmable bit error insertion** – Errors can be inserted individually, on a pin transition, or at a specific rate. The rate $1/10^n$ is programmable ($n = 1$ to 7).
- **Pattern synchronization at a 10^{-3} BER** – Pattern synchronization will be achieved even in the presence of a random Bit Error Rate (BER) of 10^{-3} .

10.11.3 Configuration and Monitoring

Set `PORT.CR1.BENA = 1` to enable the BERT. The BERT must be enabled before the pattern is loaded for the pattern load operation to take affect.

The following tables show how to configure the on-board BERT to send and receive common patterns.

Table 10-31. Pseudorandom Pattern Generation

PATTERN TYPE	BERT.PCR Register				BERT.PCR	BERT.SPR2	BERT.SPR1	BERT.CR
	PTF[4:0] (hex)	PLF[4:0] (hex)	PTS	QRSS				TPIC, RPIC
2^9-1 O.153 (511 type)	04	08	0	0	0x0408	0xFFFF	0xFFFF	0
$2^{11}-1$ O.152 and O.153 (2047 type)	08	0A	0	0	0x080A	0xFFFF	0xFFFF	0
$2^{15}-1$ O.151	0D	0E	0	0	0x0D0E	0xFFFF	0xFFFF	1
$2^{20}-1$ O.153	10	13	0	0	0x1013	0xFFFF	0xFFFF	0
$2^{20}-1$ O.151 QRSS	02	13	0	1	0x0253	0xFFFF	0xFFFF	0
$2^{23}-1$ O.151	11	16	0	0	0x1116	0xFFFF	0xFFFF	1

Table 10-32. Repetitive Pattern Generation

PATTERN TYPE	BERT.PCR Register				BERT.PCR	BERT.SPR2	BERT.SPR1
	PTF[4:0] (hex)	PLF[4:0] (hex)	PTS	QRSS			
all 1s	NA	00	1	0	0x0020	0xFFFF	0xFFFF
all 0s	NA	00	1	0	0x0020	0xFFFF	0xFFFE
alternating 1s and 0s	NA	01	1	0	0x0021	0xFFFF	0xFFFE
double alternating and 0s	NA	03	1	0	0x0023	0xFFFF	0xFFFC
3 in 24	NA	17	1	0	0x0037	0xFF20	0x0022
1 in 16	NA	0F	1	0	0x002F	0xFFFF	0x0001
1 in 8	NA	07	1	0	0x0027	0xFFFF	0xFF01
1 in 4	NA	03	1	0	0x0023	0xFFFF	0xFFF1

After configuring these bits, the pattern must be loaded into the BERT. This is accomplished via a zero-to-one transition on [BERT.CR.TNPL](#) and [BERT.CR.RNPL](#).

Monitoring the BERT requires reading the [BERT.SR](#) Register which contains the Bit Error Count (BEC) bit and the Out of Synchronization (OOS) bit. The BEC bit will be one when the bit error counter is one or more. The OOS will be one when the receive pattern generator is not synchronized to the incoming pattern, which will occur when it receives a minimum 6 bit errors within a 64 bit window. The Receive BERT Bit Count Register ([BERT.RBCR1](#)) and the Receive BERT Bit Error Count Register ([BERT.RBECR1](#)) will be updated upon the reception of a Performance Monitor Update signal (e.g. BERT.CR.LPMU). This signal will update the registers with the values of the counter since the last update and will reset the counters. See Section [10.4.5](#) for more details of the PMU.

10.11.4 Receive Pattern Detection

When the Receive BERT is enabled it can be used as an off-line monitor. The incoming datastream flows to the receive BERT as well as the DS3/E3 backplane.

The Receive BERT receives only the payload data and synchronizes the receive pattern generator to the incoming pattern. The receive pattern generator is a 32-bit shift register that shifts data from the least significant bit (LSB) or bit 1 to the most significant bit (MSB) or bit 32. The input to bit 1 is the feedback. For a PRBS pattern (generating polynomial $x^n + x^y + 1$), the feedback is an XOR of bit n and bit y. For a repetitive pattern (length n), the feedback is bit n. The values for n and y are individually programmable (1 to 32). The output of the receive pattern generator is the feedback. If QRSS is enabled, the feedback is an XOR of bits 17 and 20, and the output will be forced to one if the next 14 bits are all zeros. QRSS is programmable (on or off). For PRBS and QRSS patterns, the feedback will be forced to one if bits 1 through 31 are all zeros. Depending on the type of pattern programmed, pattern detection performs either PRBS synchronization or repetitive pattern synchronization.

10.11.4.1 Receive PRBS Synchronization

PRBS synchronization synchronizes the receive pattern generator to the incoming PRBS or QRSS pattern. The receive pattern generator is synchronized by loading 32 data stream bits into the receive pattern generator, and then checking the next 32 data stream bits. Synchronization is achieved if all 32 bits match the incoming pattern. If at least six incoming bits in the current 64-bit window do not match the receive pattern generator, automatic pattern resynchronization is initiated. Automatic pattern resynchronization can be disabled.

Refer to [Figure 10-29](#) for the PRBS synchronization diagram.

Figure 10-29. PRBS Synchronization State Diagram

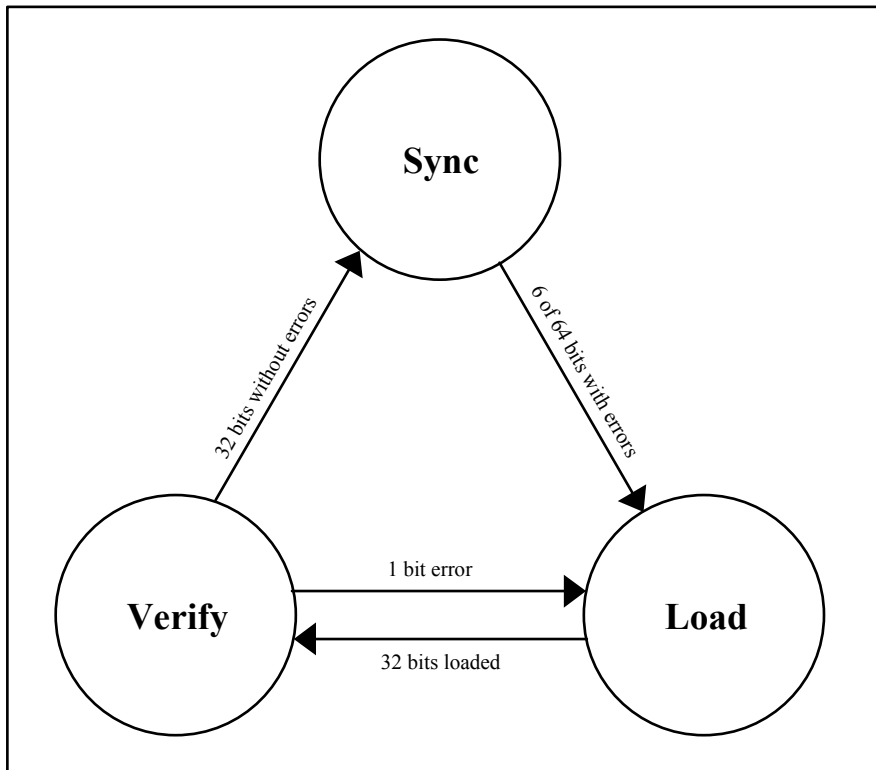

10.11.4.2 Receive Repetitive Pattern Synchronization

Repetitive pattern synchronization synchronizes the receive pattern generator to the incoming repetitive pattern. The receive pattern generator is synchronized by searching each incoming data stream bit position for the repetitive pattern, and then checking the next 32 data stream bits. Synchronization is achieved if all 32 bits match the incoming pattern. If at least six incoming bits in the current 64-bit window do not match the receive PRBS pattern generator, automatic pattern resynchronization is initiated. Automatic pattern resynchronization can be disabled.

See [Figure 10-30](#) for the repetitive pattern synchronization state diagram.

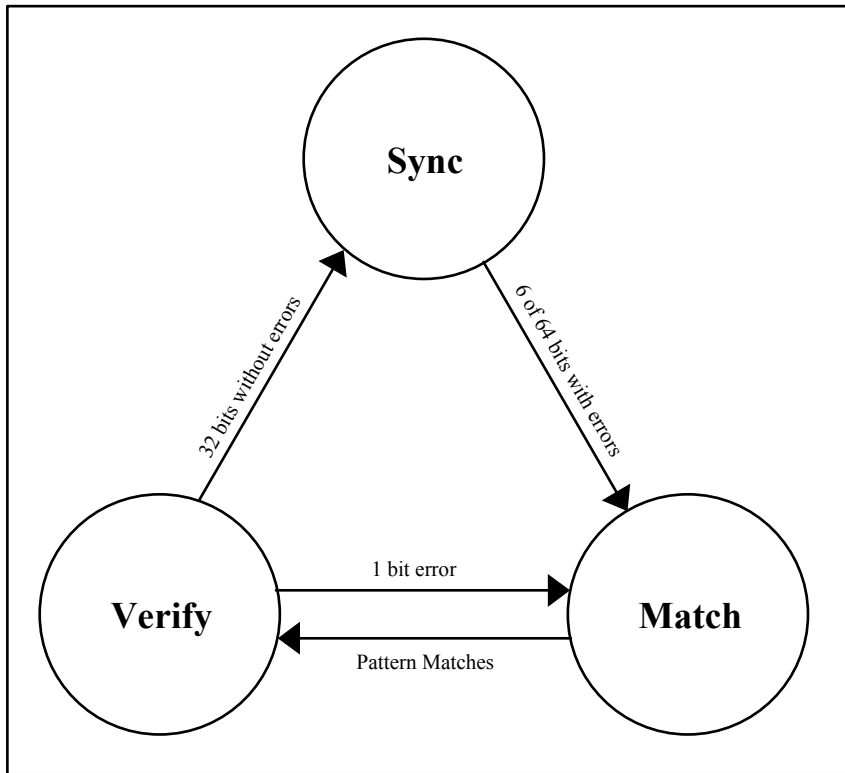
Figure 10-30. Repetitive Pattern Synchronization State Diagram

10.11.4.3 Receive Pattern Monitoring

Receive pattern monitoring monitors the incoming data stream for both an OOS condition and bit errors and counts the incoming bits. An Out Of Synchronization (OOS) condition is declared when the synchronization state machine is not in the “Sync” state. An OOS condition is terminated when the synchronization state machine is in the “Sync” state.

Bit errors are determined by comparing the incoming data stream bit to the receive pattern generator output. If they do not match, a bit error is declared, and the bit error and bit counts are incremented. If they match, only the bit count is incremented. The bit count and bit error count are not incremented when an OOS condition exists.

10.11.5 Transmit Pattern Generation

Pattern Generation generates the outgoing test pattern, and passes it onto Error Insertion. The transmit pattern generator is a 32-bit shift register that shifts data from the least significant bit (LSB) or bit 1 to the most significant bit (MSB) or bit 32. The input to bit 1 is the feedback. For a PRBS pattern (generating polynomial $x^n + x^y + 1$), the feedback is an XOR of bit n and bit y . For a repetitive pattern (length n), the feedback is bit n . The values for n and y are individually programmable (1 to 32). The output of the receive pattern generator is the feedback. If QRSS is enabled, the feedback is an XOR of bits 17 and 20, and the output will be forced to one if the next 14 bits are all zeros. QRSS is programmable (on or off). For PRBS and QRSS patterns, the feedback will be forced to one if bits 1 through 31 are all zeros. When a new pattern is loaded, the pattern generator is loaded with a seed/pattern value before pattern generation starts. The seed/pattern value is programmable ($0 - 2^n - 1$).

10.11.5.1 Transmit Error Insertion

Error insertion inserts errors into the outgoing pattern data stream. Errors are inserted one at a time or at a rate of one out of every 10^n bits. The value of n is programmable (1 to 7 or off). Single bit error insertion can be initiated from the microprocessor interface, or by the manual error insertion input (TMEI). The method of single error insertion is programmable (register or input). If pattern inversion is enabled, the data stream is inverted before the overhead/stuff bits are inserted. Pattern inversion is programmable (on or off).

10.12 LIU—Line Interface Unit

10.12.1 General Description

The line interface units (LIUs) perform the functions necessary for interfacing at the physical layer to DS3 or E3 lines. Each LIU has independent receive and transmit paths and a built-in jitter attenuator. See [Figure 10-31](#) for the location within the DS317x device of the LIU.

Figure 10-31. LIU Functional Diagram

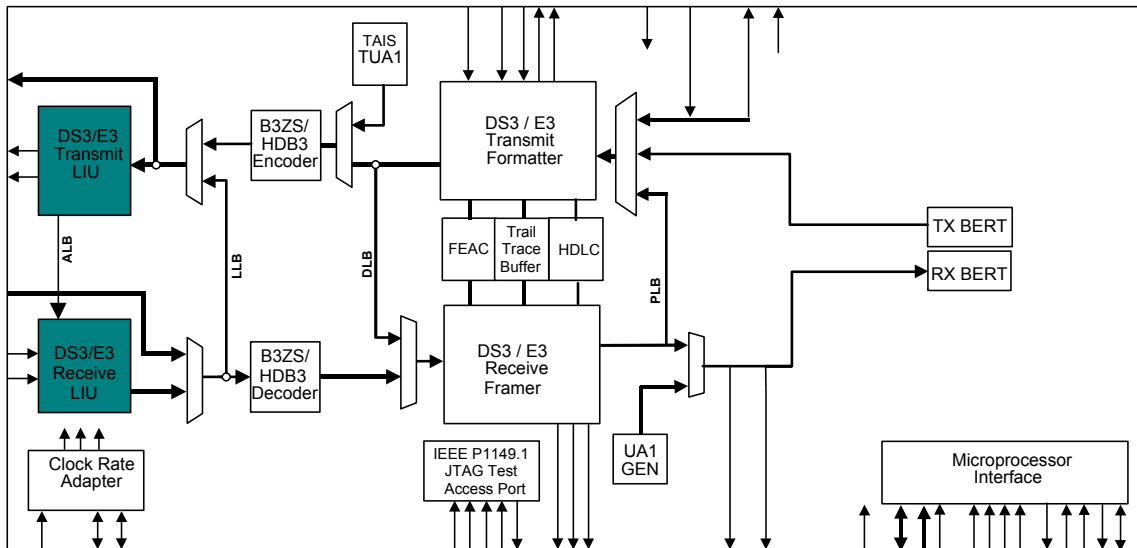

10.12.2 Features

- Each Port Independently Configurable
- Perform Receive Clock/Data Recovery and Transmit Waveshaping
- Jitter Attenuators can be Placed in Either the Receive or Transmit Paths
- Interface to 75Ω Coaxial Cable at Lengths Up to 380 meters (DS3), 440 meters (E3)
- Use 1:2 Transformers on TX and RX
- Require Minimal External Components
- Local and Remote Loopbacks

10.12.2.1 Transmitter

- Gapped clock capable up to 52MHz
- Wide 50 ±20% transmit clock duty cycle
- Clock inversion for glueless interfacing
- Unframed all-ones generator (E3 AIS)
- Line build-out (LBO) control
- Tri-state line driver outputs support protection switching applications
- Per-channel power-down control
- Output driver monitor

10.12.2.2 Receiver

- AGC/equalizer block handles from 0 to 15dB of cable loss
- Loss-of-lock (LOL) PLL status indication
- Interfaces directly to a DSX monitor signal (~20dB flat loss) using built-in preamp
- Digital and analog loss-of-signal (LOS) detectors (ANSI T1.231 and ITU G.775)
- Clock inversion for glueless interfacing
- Per-channel power-down control

10.12.3 Detailed Description

The receiver performs clock and data recovery from an alternate mark inversion (AMI) coded signal or a B3ZS- or HDB3-coded AMI signal and monitors for loss of the incoming signal. The transmitter drives standard pulse-shape waveforms onto 75Ω coaxial cable. See [Figure 10-32](#) for a detailed functional block diagram of the DS3/E3 LIU. The jitter attenuator can be mapped into the receiver data path, mapped into the transmitter data path, or be disabled. The DS3/E3 LIU conforms to the telecommunications standards listed in [Table 4-1](#). [Figure 1-1](#) shows the external components required for proper operation.

Figure 10-32. DS3/E3 LIU Block Diagram

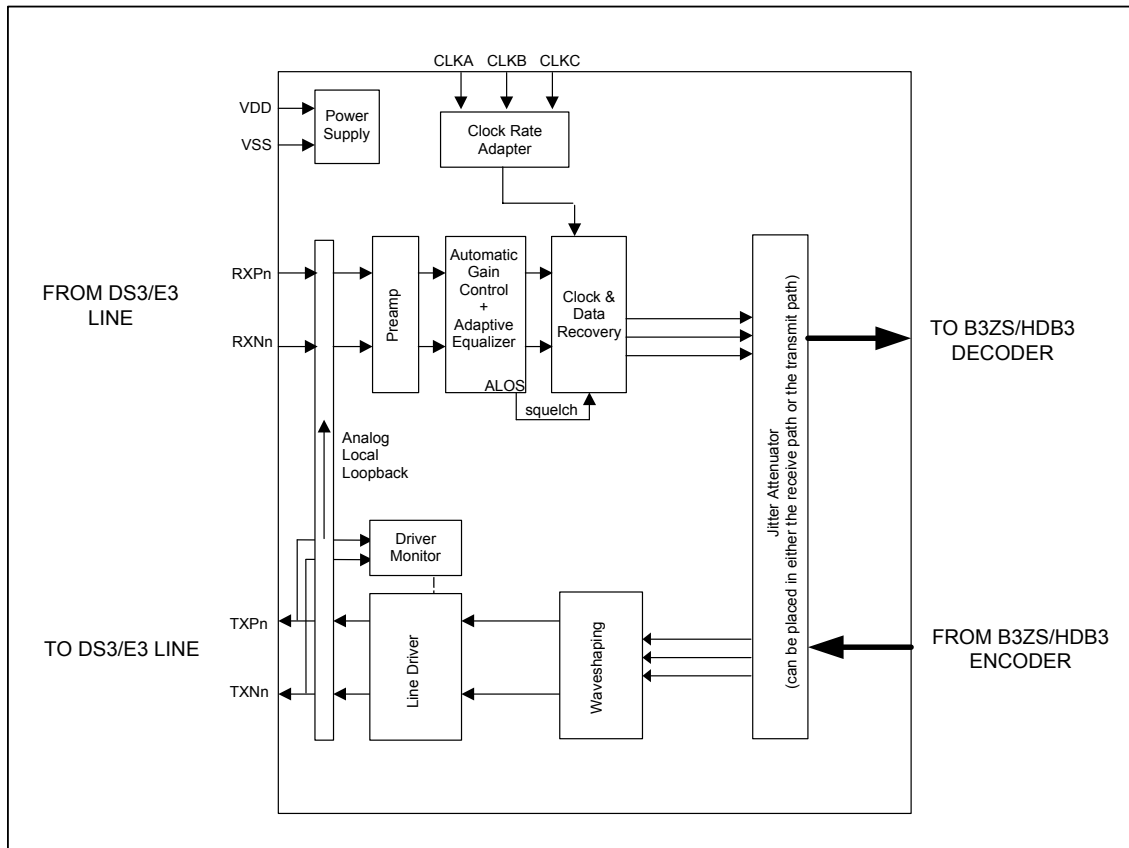

10.12.4 Transmitter

10.12.4.1 Transmit Clock

The clock used in the LIU Transmitter is typically based on either the CLAD clock or TCLKI, selected by the CLADC bit in *PORT.CR3*.

10.12.4.2 Waveshaping, Line Build-Out, Line Driver

The waveshaping block converts the transmit clock, positive data, and negative data signals into a single AMI signal with the waveshape required for interfacing to DS3/E3 lines. [Table 18-6](#) through [Table 18-8](#) and [Figure 18-9](#) (*AC Timing* section) show the waveform template specifications and test parameters.

Because DS3 signals must meet the waveform templates at the cross-connect through any cable length from 0 to 450ft, the waveshaping circuitry includes a selectable LBO feature. For cable lengths of 225ft or greater, the TLBO configuration bit (*PORT.CR2.TLBO*) should be low. When TLBO is low, output pulses are driven onto the coaxial cable without any preattenuation. For cable lengths less than 225ft, TLBO should be high to enable the LBO circuitry. When TLBO is high, pulses are preattenuated by the LBO circuitry before being driven onto the coaxial cable. The LBO circuitry provides attenuation that mimics the attenuation of 225ft of coaxial cable.

The transmitter line driver can be disabled and the TXPn and TXNn outputs tri-stated by asserting the LTS configuration bit (*PORT.CR2.LTS*). Powering down the transmitter through the TPD configuration bit (CPU bus mode) also tri-states the TXPn and TXNn outputs.

10.12.4.3 Interfacing to the Line

The transmitter interfaces to the outgoing DS3/E3 coaxial cable (75Ω) through a 2:1 step-down transformer connected to the TXPn and TXNn pins. [Figure 1-1](#) shows the arrangement of the transformer and other recommended interface components. [Table 10-33](#) specifies the required characteristics of the transformer.

10.12.4.4 Transmit Driver Monitor

If the transmit driver monitor detects a faulty transmitter, it sets the *PORT.SR.TDM* status bit. When the transmitter is tri-stated, the transmit driver monitor is also disabled. The transmitter is declared to be faulty when the transmitter outputs see a load of less than $\sim 25\Omega$.

10.12.4.5 Transmitter Power-Down

To minimize power consumption when the transmitter is not being used, assert the *PORT.CR1.PD* configuration bit. When the transmitter is powered down, the TXPn and TXNn pins are put in a high-impedance state and the transmit amplifiers are powered down.

10.12.4.6 Transmitter Jitter Generation (Intrinsic)

The transmitter meets the jitter generation requirements of all applicable standards, with or without the jitter attenuator enabled.

10.12.4.7 Transmitter Jitter Transfer

Without the jitter attenuator enabled in the transmit side, the transmitter passes jitter through unchanged. With the jitter attenuator enabled in the transmit side, the transmitter meets the jitter transfer requirements of all applicable telecommunication standards. See [Table 4-1](#).

10.12.5 Receiver

10.12.5.1 Interfacing to the Line

The receiver can be transformer-coupled or capacitor-coupled to the line. Typically, the receiver interfaces to the incoming coaxial cable (75Ω) through a 1:2 step-up transformer. [Figure 1-1](#) shows the arrangement of the transformer and other recommended interface components. [Table 10-33](#) specifies the required characteristics of the transformer. [Figure 10-32](#) shows a general overview of the LIU block. The receiver expects the incoming signal to be in B3ZS- or HDB3-coded AMI format.

Table 10-33. Transformer Characteristics

PARAMETER	VALUE
Turns Ratio	1:2ct $\pm 2\%$
Bandwidth 75Ω	0.250MHz to 500MHz (typ)
Primary Inductance	19 μ H (min)
Leakage Inductance	0.12 μ H (max)
Interwinding Capacitance	10pF (max)
Isolation Voltage	1500V _{RMS} (min)

Table 10-34. Recommended Transformers

MANUFACTURER	PART	TEMP RANGE	PIN-PACKAGE/ SCHEMATIC	OCL PRIMARY (μ H) (min)	L _L (μ H) (max)	BANDWIDTH 75 Ω (MHz)
Pulse Engineering	PE-65968	0°C to +70°C	6 SMT LS-1/C	19	0.06	0.250 to 500
Pulse Engineering	PE-65969	0°C to +70°C	6 Thru-Hole LC-1/C	19	0.06	0.250 to 500
Halo Electronics	TG07- 0206NS	0°C to +70°C	6 SMT SMD/B	19	0.06	0.250 to 500
Halo Electronics	TD07- 0206NE	0°C to +70°C	6 DIP DIP/B	19	0.06	0.250 to 500

Note: Table subject to change. Industrial temperature range and multiport transformers are also available. Contact the manufacturers for details at www.pulseeng.com and www.haloelectronics.com.

10.12.5.2 Optional Preamp

The receiver can be used in monitoring applications, which typically have series resistors with a resistive loss of approximately 20dB. When the [PORT.CR2.RMON](#) bit is high, the receiver compensates for this resistive loss by applying flat gain to the incoming signal before sending the signal to the AGC/equalizer block.

10.12.5.3 Automatic Gain Control (AGC) and Adaptive Equalizer

The AGC circuitry applies flat (frequency independent) gain to the incoming signal to compensate for flat losses in the transmission channel and variations in transmission power. Since the incoming signal also experiences frequency-dependent losses as it passes through the coaxial cable, the adaptive equalizer circuitry applies frequency-dependent gain to offset line losses and restore the signal. The AGC/equalizer circuitry automatically adapts to coaxial cable losses from 0 to 15dB, which translates into 0 to 380 meters (DS3) or 0 to 440 meters (E3) of coaxial cable (AT&T 734A or equivalent). The AGC and the equalizer work simultaneously but independently to supply a signal of nominal amplitude and pulse shape to the clock and data recovery block. The AGC/equalizer block automatically handles direct (0 meters) monitoring of the transmitter output signal.

10.12.5.4 Clock and Data Recovery (CDR)

The CDR block takes the amplified, equalized signal from the AGC/equalizer block and produces a separate clock, positive data, and negative data signals. The CDR requires a master clock. This clock is derived from CLKA, CLKB, or CLKC depending on the CLAD configuration (DS3, E3). If, however, there is no clock source on CLKA, CLKB, or CLKC the CDR block will automatically switch to TCLKIn to use as its master clock.

The receive clock is locked using a clock recovery PLL. The status of the PLL lock is indicated in the RLOL ([PORT.SR](#)) status bit. The receive loss-of-lock status bit (RLOL) is set when the difference between the recovered clock frequency and the master clock frequency is greater than 7900ppm and cleared when the difference is less than 7700ppm. A change of state of the *PORT.SR.RLOL* status bit can cause an interrupt on the $\overline{\text{INT}}$ pin if enabled to do so by the *PORT.SR.IE.RLOLIE* interrupt-enable bit. Note that if the master clock is not present, or the master clock is high and TCLK is not present, RLOL is not set.

10.12.5.5 Loss-of-Signal (LOS) Detector

The receiver contains analog and digital LOS detectors. The analog LOS detector resides in the AGC/equalizer block. If the incoming signal level is less than a signal level approximately 24dB below nominal, analog LOS (ALOS) is declared. The ALOS signal cannot be directly examined, but when ALOS occurs the AGC/equalizer mutes the recovered data, forcing all zeros out of the data recovery circuitry and causing digital LOS (DLOS). DLOS is determined by the Line Decoder block (see [10.10.6](#)) and indicated by the LOS status bit ([LINE.RSR.LOS](#)).

ALOS clears when the incoming signal level is greater than or equal to a signal level approximately 18dB below nominal.

For E3 LOS Assertion:

The ALOS detector in the AGC/equalizer block detects that the incoming signal is less than or equal to a signal level approximately 24dB below nominal, and mutes the data coming out of the clock and data recovery block. (24dB below nominal in the “tolerance range” of G.775, where LOS may or may not be declared.)

For E3 LOS Clear:

The ALOS detector in the AGC/equalizer block detects that the incoming signal is greater than or equal to a signal level approximately 18dB below nominal, and enables data to come out of the CDR block. (18dB is in the “tolerance range” of G.775, where LOS may or may not be declared.)

10.12.5.6 Receiver Power-Down

To minimize power consumption when the receiver is not being used, write a one to the *PORT.CR1.PD* bit. When the receiver is powered down, the RCLKOn pin is tri-stated. In addition, the RXPn and RXNn pins become high impedance.

10.12.5.7 Receiver Jitter Tolerance.

The receiver exceeds the input jitter tolerance requirements of all applicable telecommunication standards in [Table 4-1](#). See [Figure 10-33](#).

Figure 10-33. Receiver Jitter Tolerance

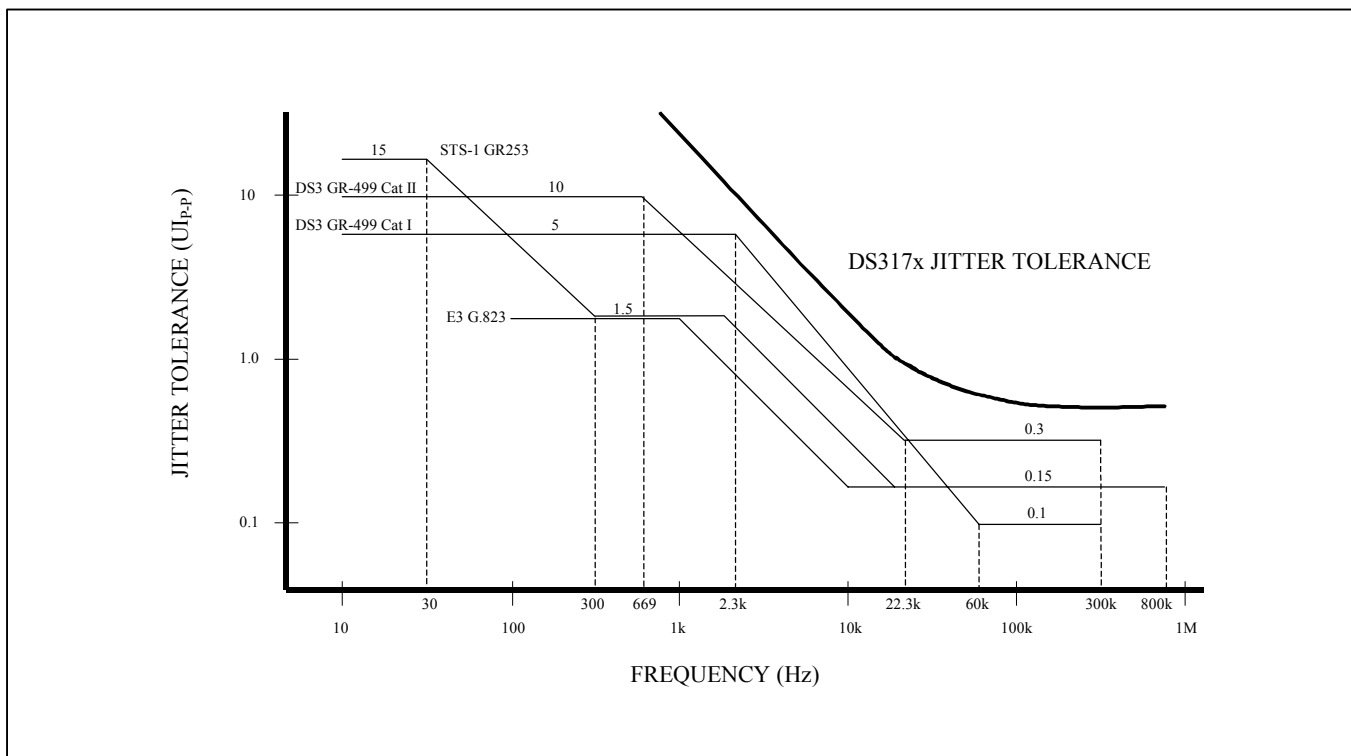

11 OVERALL REGISTER MAP

The register addresses of the global, test, and all four ports are concatenated to cover the address range of 000 to 7FF. The address map requires 11 bits of address, ADR[10:0]. The upper address bit A[10] is decoded for the DS3174 and DS3173 devices. The upper address bit A[10] it is not used by the DS3172 and DS3171 devices and must be tied low at the pin.

The register banks that are not marked with an “X” are not writeable and read back all zeros. Bits that are underlined are read-only; all other bits are read-write.

After Global Reset, all Registers will be reset to their default values.

When writing to registers with unused bits marked with “—”, always write a zero to these unused bits and ignore the value read back from these bits.

Configuration registers can be written to and read from during a data path reset (\overline{DRST} low, and \overline{RST} high). However, all changes to these registers will be ignored during the data path reset. As a result, all initiating action requiring a “0 to 1” transition must be re-initiated after the data path reset is released.

All counters saturate at their maximum count. A counter register is updated by asserting (low to high transition) the performance monitoring update signal (RPMU). During the counter register update process, the performance monitoring status signal (RPMS) will be deasserted. The counter register update process consists of loading the counter register with the current count, resetting the counter, forcing the zero count status indication low for one clock period, and then asserting RPMS. No events shall be missed during an update procedure.

A latched bit is set when the associated event occurs, and remains set until it is cleared. Once cleared, a latched bit will not be set again until the associated event reoccurs (goes away and comes back). A latched on change bit is a latched bit that is set when the event occurs, and when it goes away. A latched status bit can be cleared using clear on read or clear on write techniques, selectable by the [GL.CR1.LSBCRE](#) bit. When clear on read is selected, the latched bits in a latched status register will be cleared after the register is read from. If the device is configured for 16-bit mode, all 16 latched status bits will be cleared. If the device is configured for 8-bit mode, only the 8 bits being accessed will be cleared. When clear on write is selected, the latched bits in a latched status register will be cleared when a logic 1 is written to that bit position. For example, writing a FFFFh to a 16-bit latched status register will clear any latched status bit, whereas writing a 0001h will only clear latched bit 0 of the latched status register.

Reserved bits and registers are implemented in a different mode. Reserved configuration bits and registers can be written and read, however they will not effect the operation of the current mode. Reserved status bits will be zero. Reserved latched status bits cannot be set, however, they may remain set or get set during a mode change. Reserved interrupt enable bits can be written and read, and can cause an interrupt if the associated latched status bit is set. Reserved counter registers and the associated counter will retain the values held before a mode change, however, the associated counter cannot be incremented. A performance monitor update will operate normally. If the data path reset is set during or after a mode change, the latched status bits and counter registers (with the associated counters) will be automatically cleared. If the data path reset is not used, then the latched status bits must be cleared via the register interface in the normal manner. And, the counter registers must be cleared by performing two performance monitor updates. The first to clear the associated counter, and load the current count into the counter register, and the second to clear the counter register.

Table 11-1. Global and Test Register Address Map

ADDRESS	DESCRIPTION
000–01F	Global registers, Section 12.1
020–02F	Unused
030–03F	Reserved
040–1FF	Port 1 Register Map
200–23F	Test Registers
240–3FF	Port 2 Register Map
400–43F	Test Registers
440–5FF	Port 3 Register Map
600–63F	Unused
640–6FF	Port 4 Register Map

Each port has a relative address range of 040h to 1FFh. The lower 000h to 03Fh address range is used for global, test and reserved registers. The following table is a map of the registers for each port. The address offset is from the start of each port range of 000h, 200h, 400h, and 600h. In a DS3183, writes to registers in port 4 will be ignored and reads from port 4 registers will read back zero values. Similarly, in a DS3181, writes to registers in port 2 will be ignored and reads from port 2 will read back zero values.

Note: The \overline{RDY} signal will not go active if the user attempts to read or write unused ports or unused registers not assigned to any design blocks. The \overline{RDY} signal will go active if the user writes or reads reserved registers or unused registers within design blocks.

Table 11-2. Per Port Register Address Map

Port 1	Port 2	Port 3	Port 4
040 to 1FF	240 to 3FF	440 to 5FF	640 to 7FF

ADDRESS OFFSET	DESCRIPTION
040–05F	Port common registers
060–07F	BERT
080–08B	Reserved
08C–08F	B3ZS/HDB3 transmit line encoder
090–09F	B3ZS/HDB3 receive line decoder
0A0–0AF	HDLC Transmit
0B0–0BF	HDLC Receive
0C0–0CF	FEAC Transmit
0D0–0DF	FEAC Receive
0E0–0E7	Reserved
0E8–0EF	Trail Trace Transmit
0F0–0FF	Trail Trace Receive
100–117	Reserved
118–11F	DS3/E3 Framer Transmit
120–13F	DS3/E3 Framer Receive
140–1FF	Reserved

12 REGISTER MAPS AND DESCRIPTIONS

12.1 Registers Bit Maps

Note: In 8-bit mode, register bits[15:8] correspond to the upper byte, and register bits[7:0] correspond to the lower byte. For example, address 001h is the upper byte (bits [15:8]) and address 000h is the lower byte (bits [7:0]) for register GL.IDR in 8-bit mode.

All registers listed, including those designated Unused and Reserved, will cause the $\overline{\text{RDY}}$ signal to go low when written to or read from.

The “—” designation indicates that the bit is not assigned.

12.1.1 Global Register Bit Map

Table 12-1. Global Register Bit Map

Address 16-bit	8-bit	Register	Type	Bit 7	Bit 6	Bit 5	Bit 4	Bit 3	Bit 2	Bit 1	Bit 0
				Bit 15	Bit 14	Bit 13	Bit 12	Bit 11	Bit 10	Bit 9	Bit 8
000	000	GL.IDR	R	ID7	ID6	ID5	ID4	ID3	ID2	ID1	ID0
	001			ID15	ID14	ID13	ID12	ID11	ID10	ID9	ID8
002	002	GL.CR1	RW	TMEI	MEIMS	GPM1	GPM0	PMU	LSBCRE	RSTDP	RST
	003			GWRM	INTM	RES	--	RES	RES	RES	RES
004	004	GL.CR2	RW	--	--	--	--	CLAD3	CLAD2	CLAD1	CLAD0
	005			--	--	--	G8KRS2	G8KRS1	G8KRS0	G8K0S	G8KIS
006-008	006-009	UNUSED		--	--	--	--	--	--	--	--
				--	--	--	--	--	--	--	--
00A	00A	GL.GIOCR	RW	GPIO4S1	GPIO4S0	GPIO3S1	GPIO3S0	GPIO2S1	GPIO2S0	GPIO1S1	GPIO1S0
	00B			GPIO8S1	GPIO8S0	GPIO7S1	GPIO7S0	GPIO6S1	GPIO6S0	GPIO5S1	GPIO5S0
00C	00C	UNUSED		--	--	--	--	--	--	--	--
	00D			--	--	--	--	--	--	--	--
010	010	GL.ISR	R	PISR4	PISR3	PISR2	PISR1	--	--	RES	GSR
	011			--	--	--	--	--	--	--	--
012	012	GL.ISRIE	RW	PISRIE4	PISRIE3	PISRIE2	PISRIE1	--	--	RES	GSRIE
	013			--	--	--	--	--	--	--	--
014	014	GL.SR	R	--	--	--	--	--	--	CLOL	GPMS
	015			--	--	--	--	--	--	--	--
016	016	GL.SRL	RL	--	--	--	8KREFL	CLADL	ONESL	CLOLL	GPMSL
	017			--	--	--	--	--	--	--	--
018	018	GL.SRIE	R	--	--	--	--	--	ONESIE	CLOLIE	GPMSIE
	019			--	--	--	--	--	--	--	--
01A	01A	UNUSED		--	--	--	--	--	--	--	--
	01B			--	--	--	--	--	--	--	--
01C	01C	GL.GIORR	R	GPIO8	GPIO7	GPIO6	GPIO5	GPIO4	GPIO3	GPIO2	GPIO1
	01D			--	--	--	--	--	--	--	--
01E	01E	UNUSED		--	--	--	--	--	--	--	--
	01F			--	--	--	--	--	--	--	--

Table 12-2. Port Register Bit Map**Note:** J and K are variable dependent upon port.

	Port 1	Port 2	Port 3	Port 4
J	0	2	4	6
K	1	3	5	7

Address 16-bit	8-bit	Register	Type	Bit 7	Bit 6	Bit 5	Bit 4	Bit 3	Bit 2	Bit 1	Bit 0
				Bit 15	Bit 14	Bit 13	Bit 12	Bit 11	Bit 10	Bit 9	Bit 8
J40	J40 J41	PORT.CR1	RW	TMEI	MEIM	--	PMUM	PMU	PD	RSTDP	RST
				RES	PAIS2	PAIS1	PAIS0	LAIS1	LAIS0	BENA	RES
J42	J42 J43	PORT.CR2	RW	RES	RES	FM2	FM1	FM0	RES	RES	RES
				TLEN	TTS	RMON	TLBO	RES	LM2	LM1	LM0
J44	J44 J45	PORT.CR3	RW	P8KRS1	P8KRS0	P8KREF	LOOPT	CLADC	RFTS	TFTS	TLTS
				--	--	RCLKS	RSOFOS	RES	TCLKS	TSOFOS	RES
J46	J46 J47	PORT.CR4	RW	GPIOB3	GPIOB2	GPIOB1	GPIOB0	GPIOA3	GPIOA2	GPIOA1	GPIOA0
				--	--	--	--	RES	LBM2	LBM1	LBM0
J48	J48 J49	UNUSED		--	--	--	--	--	--	--	--
				--	--	--	--	--	--	--	--
J4A	J4A J4B	PORT.INV1	RW	TOHI	TOHCKI	TSOFI1	TNEGI	TDATI	TLCKI	TCKOI	TCKII
				RES	RES	--	TSOFOI	RES	TSERI	TOHSI	TOHEI
J4C	J4C J4D	PORT.INV2	RW	ROHI	ROHCKI	--	RNEGI	RPOSI	RLCKI	RCLKOI	--
				--	RES	RES	RSOFOI	--	RSERI	ROHSI	--
J4E	J4E J4F	UNUSED		--	--	--	--	--	--	--	--
				--	--	--	--	--	--	--	--
J50	J50 J51	PORT.ISR	R	<u>TTSR</u>	<u>FSR</u>	<u>HSR</u>	<u>BSR</u>	RES	RES	RES	<u>FMSR</u>
				--	--	--	--	--	--	<u>PSR</u>	<u>LCRSR</u>
J52	J52 J53	PORT.SR	R	--	--	--	--	--	<u>TDM</u>	<u>RLOL</u>	<u>PMS</u>
				--	--	--	--	--	--	--	--
J54	J54 J55	PORT.SRL	RL	RLCLKA	TCLKIA	--	--	--	TDML	RLOLL	PMSL
				--	--	--	--	--	--	--	--
J56	J56 J57	PORT.SRIE	RW	--	--	--	--	--	TDMIE	RLOLIE	PMSIE
				--	--	--	--	--	--	--	--
J58- J5E	J58- J5F	UNUSED		--	--	--	--	--	--	--	--
				--	--	--	--	--	--	--	--

Table 12-3. BERT Register Bit Map

Address 16-bit	8-bit	Register	Type	Bit 7	Bit 6	Bit 5	Bit 4	Bit 3	Bit 2	Bit 1	Bit 0
				Bit 15	Bit 14	Bit 13	Bit 12	Bit 11	Bit 10	Bit 9	Bit 8
J60	J60 J61	BERT.CR	RW	PMUM	LPMU	RNPL	RPIC	MPR	APRD	TNPL	TPIC
				--	--	--	--	--	--	--	--
J62	J62 J63	BERT.PCR	RW	--	QRSS	PTS	PLF4	PLF3	PLF2	PLF1	PLF0
				--	--	--	PTF4	PTF3	PTF2	PTF1	PTF0
J64	J64 J65	BERT.SPR1	RW	BSP7	BSP6	BSP5	BSP4	BSP3	BSP2	BSP1	BSP0
				BSP15	BSP14	BSP13	BSP12	BSP11	BSP10	BSP9	BSP8
J66	J66 J67	BERT.SPR2	RW	BSP23	BSP22	BSP21	BSP20	BSP19	BSP18	BSP17	BSP16
				BSP31	BSP30	BSP29	BSP28	BSP27	BSP26	BSP25	BSP24
J68	J68 J69	BERT.TEICR	RW	--	--	TEIR2	TEIR1	TEIR0	BEI	TSEI	MEIMS
				--	--	--	--	--	--	--	--
J6A	J6A J6B	UNUSED		--	--	--	--	--	--	--	--
				--	--	--	--	--	--	--	--

Address		Register	Type	Bit 7	Bit 6	Bit 5	Bit 4	Bit 3	Bit 2	Bit 1	Bit 0
16-bit	8-bit			Bit 15	Bit 14	Bit 13	Bit 12	Bit 11	Bit 10	Bit 9	Bit 8
J6C	J6C	BERT.SR	R	--	--	--	--	<u>PMS</u>	--	<u>BEC</u>	<u>OOS</u>
	J6D			--	--	--	--	--	--	--	--
J6E	J6E	BERT.SRL	RL	--	--	--	--	<u>PMSL</u>	<u>BEL</u>	<u>BECL</u>	<u>OOSL</u>
	J6F			--	--	--	--	--	--	--	--
J70	J70	BERT.SRIE	RW	--	--	--	--	PMSIE	BEIE	BECIE	OOSIE
	J71			--	--	--	--	--	--	--	--
J72	J72	UNUSED		--	--	--	--	--	--	--	--
	J73			--	--	--	--	--	--	--	--
J74	J74	BERT.RBECR1	R	<u>BEC7</u>	<u>BEC6</u>	<u>BEC5</u>	<u>BEC4</u>	<u>BEC3</u>	<u>BEC2</u>	<u>BEC1</u>	<u>BEC0</u>
	J75			<u>BEC15</u>	<u>BEC14</u>	<u>BEC13</u>	<u>BEC12</u>	<u>BEC11</u>	<u>BEC10</u>	<u>BEC9</u>	<u>BEC8</u>
J76	J76	BERT.RBECR2	R	<u>BEC23</u>	<u>BEC22</u>	<u>BEC21</u>	<u>BEC20</u>	<u>BEC19</u>	<u>BEC18</u>	<u>BEC17</u>	<u>BEC16</u>
	J77			--	--	--	--	--	--	--	--
J78	J78	BERT.RBCR1	R	<u>BC7</u>	<u>BC6</u>	<u>BC5</u>	<u>BC4</u>	<u>BC3</u>	<u>BC2</u>	<u>BC1</u>	<u>BC0</u>
	J79			<u>BC15</u>	<u>BC14</u>	<u>BC13</u>	<u>BC12</u>	<u>BC11</u>	<u>BC10</u>	<u>BC9</u>	<u>BC8</u>
J7A	J7A	BERT.RBCR2	R	<u>BC23</u>	<u>BC22</u>	<u>BC21</u>	<u>BC20</u>	<u>BC19</u>	<u>BC18</u>	<u>BC17</u>	<u>BC16</u>
	J7B			<u>BC31</u>	<u>BC30</u>	<u>BC29</u>	<u>BC28</u>	<u>BC27</u>	<u>BC26</u>	<u>BC25</u>	<u>BC24</u>
J7C- J7E	J7C	UNUSED		--	--	--	--	--	--	--	--
	J7F			--	--	--	--	--	--	--	--

Table 12-4. Line Register Bit Map

Address		Register	Type	Bit 7	Bit 6	Bit 5	Bit 4	Bit 3	Bit 2	Bit 1	Bit 0
16-bit	8-bit			Bit 15	Bit 14	Bit 13	Bit 12	Bit 11	Bit 10	Bit 9	Bit 8
J8C	J8C	LINE.TCR	RW	--	--	--	TZSD	EXZI	BPVI	TSEI	MEIMS
	J8D			--	--	--	--	--	--	--	--
J8E	J8E	UNUSED		--	--	--	--	--	--	--	--
	J8F			--	--	--	--	--	--	--	--
J90	J90	LINE.RCR	RW	--	--	--	--	E3CVE	REZSF	RDZSF	RZSD
	J91			--	--	--	--	--	--	--	--
J92	J92	UNUSED		--	--	--	--	--	--	--	--
	J93			--	--	--	--	--	--	--	--
J94	J94	LINE.RSR	R	--	--	--	--	<u>EXZC</u>	--	<u>BPVC</u>	<u>LOS</u>
	J95			--	--	--	--	--	--	--	--
J96	J96	LINE.RSRL	RL	--	--	<u>ZSCDL</u>	<u>EXZL</u>	<u>EXZCL</u>	<u>BPVL</u>	<u>BPVCL</u>	<u>LOSL</u>
	J97			--	--	--	--	--	--	--	--
J98	J98	LINE.RSRIE	RW	--	--	ZSCDIE	EXZIE	EXZCIE	BPVIE	BPVCIE	LOSIE
	J99			--	--	--	--	--	--	--	--
J9A	J9A	UNUSED		--	--	--	--	--	--	--	--
	J9B			--	--	--	--	--	--	--	--
J9C	J9C	LINE.RBPVCR	R	<u>BPV7</u>	<u>BPV6</u>	<u>BPV5</u>	<u>BPV4</u>	<u>BPV3</u>	<u>BPV2</u>	<u>BPV1</u>	<u>BPV0</u>
	J9D			<u>BPV15</u>	<u>BPV14</u>	<u>BPV13</u>	<u>BPV12</u>	<u>BPV11</u>	<u>BPV10</u>	<u>BPV9</u>	<u>BPV8</u>
J9E	J9E	LINE.REXZCR	R	<u>EXZ7</u>	<u>EXZ6</u>	<u>EXZ5</u>	<u>EXZ4</u>	<u>EXZ3</u>	<u>EXZ2</u>	<u>EXZ1</u>	<u>EXZ0</u>
	J9F			<u>EXZ15</u>	<u>EXZ14</u>	<u>EXZ13</u>	<u>EXZ12</u>	<u>EXZ11</u>	<u>EXZ10</u>	<u>EXZ9</u>	<u>EXZ8</u>

12.1.2 HDLC Register Bit Map

Table 12-5. HDLC Register Bit Map

Address		Register	Type	Bit 7	Bit 6	Bit 5	Bit 4	Bit 3	Bit 2	Bit 1	Bit 0
16-bit	8-bit			Bit 15	Bit 14	Bit 13	Bit 12	Bit 11	Bit 10	Bit 9	Bit 8
JA0	JA0	HDLC.TCR	RW	--	TPSD	TFEI	TIFV	TBRE	TDIE	TFPD	TFRST
	JA1			--	--	--	TDAL4	TDAL3	TDAL2	TDAL1	TDAL0
JA2	JA2	HDLC.TFDR	RW	--	--	--	--	--	--	--	TDPE
	JA3			TFD7	TFD6	TFD5	TFD4	TFD3	TFD2	TFD1	TFD0
JA4	JA4	HDLC.TSR	R	--	--	--	--	--	<u>TFE</u>	<u>TFE</u>	<u>THDA</u>
	JA5			--	--	<u>TFFL5</u>	<u>TFFL4</u>	<u>TFFL3</u>	<u>TFFL2</u>	<u>TFFL1</u>	<u>TFFL0</u>
JA6	JA6	HDLC.TSRL	RL	--	--	<u>TFOL</u>	<u>TFUL</u>	<u>TPEL</u>	--	<u>TFEL</u>	<u>THDAL</u>
	JA7			--	--	--	--	--	--	--	--
JA8	JA8	HDLC.TSRIE	RW	--	--	TFOIE	TFUIE	TPEIE	--	TFEIE	THDAIE
	JA9			--	--	--	--	--	--	--	--
JAA-JAE	JAA	UNUSED		--	--	--	--	--	--	--	--
	JAE			JAF	--	--	--	--	--	--	--
JB0	JB0	HDLC.RCR	RW	--	--	--	--	RBRE	RDIE	RFPD	RFRST
	JB1			--	--	--	RDAL4	RDAL3	RDAL2	RDAL1	RDAL0
JB2	JB2	UNUSED		--	--	--	--	--	--	--	--
	JB3			--	--	--	--	--	--	--	--
JB4	JB4	HDLC.RSR	R	--	--	--	--	--	<u>RFE</u>	<u>RFE</u>	<u>RHDA</u>
	JB5			--	--	--	--	--	--	--	--
JB6	JB6	HDLC.RSRL	RL	<u>RFOL</u>	--	--	<u>RPEL</u>	<u>RPSL</u>	<u>RFFL</u>	--	<u>RHDAL</u>
	JB7			--	--	--	--	--	--	--	--
JB8	JB8	HDLC.RSRIE	RW	RFOIE	--	--	RPEIE	RPSIE	RFFIE	--	RHDAIE
	JB9			--	--	--	--	--	--	--	--
JBA	JBA	UNUSED		--	--	--	--	--	--	--	--
	JBB			--	--	--	--	--	--	--	--
JBC	JBC	HDLC.RFDR	R	--	--	--	--	<u>RPS2</u>	<u>RPS1</u>	<u>RPS0</u>	<u>RFDV</u>
	JBD			<u>RFD7</u>	<u>RFD6</u>	<u>RFD5</u>	<u>RFD4</u>	<u>RFD3</u>	<u>RFD2</u>	<u>RFD1</u>	<u>RFD0</u>
JBE	JBE	UNUSED		--	--	--	--	--	--	--	--
	JBF			--	--	--	--	--	--	--	--

Table 12-6. FEAC Register Bit Map

Address		Register	Type	Bit 7	Bit 6	Bit 5	Bit 4	Bit 3	Bit 2	Bit 1	Bit 0
16-bit	8-bit			Bit 15	Bit 14	Bit 13	Bit 12	Bit 11	Bit 10	Bit 9	Bit 8
JC0	JC0	FEAC.TCR	RW	--	--	--	--	--	TFCL	TFS1	TFS0
	JC1			--	--	--	--	--	--	--	--
JC2	JC2	FEAC.TFDR	RW	--	--	TFCA5	TFCA4	TFCA3	TFCA2	TFCA1	TFCA0
	JC3			--	--	TFCB5	TFCB4	TFCB3	TFCB2	TFCB1	TFCB0
JC4	JC4	FEAC.TSR	R	--	--	--	--	--	--	--	<u>TFI</u>
	JC5			--	--	--	--	--	--	--	--
JC6	JC6	FEAC.TSRL	RL	--	--	--	--	--	--	--	<u>TFIL</u>
	JC7			--	--	--	--	--	--	--	--
JC8	JC8	FEAC.TSRIE	RW	--	--	--	--	--	--	--	TFIIE
	JC9			--	--	--	--	--	--	--	--
JCA-JCE	JCA	UNUSED		--	--	--	--	--	--	--	--
	JCE			JCF	--	--	--	--	--	--	--

Address		Register	Type	Bit 7	Bit 6	Bit 5	Bit 4	Bit 3	Bit 2	Bit 1	Bit 0
16-bit	8-bit			Bit 15	Bit 14	Bit 13	Bit 12	Bit 11	Bit 10	Bit 9	Bit 8
JD0	JD0	FEAC.RCR	RW	--	--	--	--	--	--	--	RFR
	JD1			--	--	--	--	--	--	--	--
JD2	JD2	UNUSED		--	--	--	--	--	--	--	--
	JD3			--	--	--	--	--	--	--	--
JD4	JD4	FEAC.RSR	R	--	--	--	--	RFFE	--	RFCD	RFI
	JD5			--	--	--	--	--	--	--	--
JD6	JD6	FEAC.RSRL	RL	--	--	--	--	--	RFFOL	RFCDL	RFIL
	JD7			--	--	--	--	--	--	--	--
JD8	JD8	FEAC.RSRIE	RW	--	--	--	--	--	RFFOIE	RFCDIE	RFIIE
	JD9			--	--	--	--	--	--	--	--
JDA	JDA	UNUSED		--	--	--	--	--	--	--	--
	JDB			--	--	--	--	--	--	--	--
JDC	JDC	FEAC.RFDR	R	RFFI	--	RFF5	RFF4	RFF3	RFF2	RFF1	RFF0
	JDD			--	--	--	--	--	--	--	--
JDE	JDE	UNUSED		--	--	--	--	--	--	--	--
	JDF			--	--	--	--	--	--	--	--

Table 12-7. Trail Trace Register Bit Map

Address		Register	Type	Bit 7	Bit 6	Bit 5	Bit 4	Bit 3	Bit 2	Bit 1	Bit 0
16-bit	8-bit			Bit 15	Bit 14	Bit 13	Bit 12	Bit 11	Bit 10	Bit 9	Bit 8
JE8	JE8	TT.TCR	RW	--	--	--	Reserved	TMAD	TIDLE	TDIE	TBRE
	JE9			--	--	--	--	--	--	--	--
JEA	JEA	TT.TTIAR	R	--	--	Reserved	Reserved	TTIA3	TTIA2	TTIA1	TTIA0
	JEB			--	--	--	--	--	--	--	--
JEC	JEC	TT.TIR	R	TTD7	TTD6	TTD5	TTD4	TTD3	TTD2	TTD1	TTD0
	JED			--	--	--	--	--	--	--	--
JEE	JEE	UNUSED		--	--	--	--	--	--	--	--
	JEF			--	--	--	--	--	--	--	--
JF0	JF0	TT.RCR	RW	--	--	Reserved	Reserved	RMAD	RETCD	RDIE	RBRE
	JF1			--	--	--	--	--	--	--	--
JF2	JF2	TT.RTIAR	R	--	--	Reserved	Reserved	RTIA3	RTIA2	RTIA1	RTIA0
	JF3			--	--	Reserved	Reserved	ETIA3	ETIA2	ETIA1	ETIA0
JF4	JF4	TT.RSR	R	--	--	--	--	--	RTIM	RTIU	RIDL
	JF5			--	--	--	--	--	--	--	--
JF6	JF6	TT.RSRL	RL	--	--	--	--	RTICL	RTIML	RTIUL	RIDLL
	JF7			--	--	--	--	--	--	--	--
JF8	JF8	TT.RSRIE	RW	--	--	--	--	RTICIE	RTIMIE	RTIUIE	RIDLIE
	JF9			--	--	--	--	--	--	--	--
JFA	JFA	UNUSED		--	--	--	--	--	--	--	--
	JFB			--	--	--	--	--	--	--	--
JFC	JFC	TT.RIR	R	RTD7	RTD6	RTD5	RTD4	RTD3	RTD2	RTD1	RTD0
	JFD			--	--	--	--	--	--	--	--
JFE	JFE	TT.EIR	R	ETD7	ETD6	ETD5	ETD4	ETD3	ETD2	ETD1	ETD0
	JFF			--	--	--	--	--	--	--	--
K00-K16	K00-K117	RESERVED		--	--	--	--	--	--	--	--
				--	--	--	--	--	--	--	--

12.1.3 T3 Register Bit Map

Table 12-8. T3 Register Bit Map

Address		Register	Type	Bit 7	Bit 6	Bit 5	Bit 4	Bit 3	Bit 2	Bit 1	Bit 0
16-bit	8-bit			Bit 15	Bit 14	Bit 13	Bit 12	Bit 11	Bit 10	Bit 9	Bit 8
K18	K18	T3.TCR	RW	--	--	TFEBE	AFEBED	TRDI	ARDID	TFGD	TAIS
	K19			--	--	--	PBGE	TIDLE	CBGD	--	--
K1A	K1A	T3.TEIR	RW	Reserved	CPEIE	PEI	FEIC1	FEIC0	FEI	TSEI	MEIMS
	K1B			--	--	--	--	CCPEIE	CPEI	CFBEIE	FBEI
K1C- K1E	K1C K1F	RESERVED		--	--	--	--	--	--	--	--
				--	--	--	--	--	--	--	--
K20	K20 K21	T3.RCR	RW	RAILE	RAILD	RAIOD	RAIAD	ROMD	LIP1	LIP0	FRSYNC
				Reserved	COVHD	MAOD	MDAIS1	AAISD	ECC	FECC1	FECC0
K22	K22 K23	RESERVED		--	--	--	--	--	--	--	--
				--	--	--	--	--	--	--	--
K24	K24 K25	T3.RSR1	R	<u>OOMF</u>	<u>SEF</u>	--	<u>LOF</u>	<u>RAI</u>	<u>AIS</u>	<u>OOF</u>	<u>LOS</u>
				Reserved	Reserved	--	Reserved	<u>T3FM</u>	<u>AIC</u>	<u>IDLE</u>	<u>RUA1</u>
K26	K26 K27	T3.RSR2	R	--	--	--	--	<u>CPEC</u>	<u>FBEC</u>	<u>PEC</u>	<u>FEC</u>
				--	--	--	--	--	--	--	--
K28	K28 K29	T3.RSRL1	RL	<u>OOMFL</u>	<u>SEFL</u>	<u>COFAL</u>	<u>LOFL</u>	<u>RAIL</u>	<u>AISL</u>	<u>OOFL</u>	<u>LOSL</u>
				Reserved	Reserved	Reserved	Reserved	<u>T3FML</u>	<u>AICL</u>	<u>IDLEL</u>	<u>RUA1L</u>
K2A	K2A K2B	T3.RSRL2	RL	--	--	--	--	<u>CPECL</u>	<u>FBECCL</u>	<u>PECL</u>	<u>FECCL</u>
				--	--	--	--	<u>CPEL</u>	<u>FBEL</u>	<u>PEL</u>	<u>FEL</u>
K2C	K2C K2D	T3.RSRIE1	RW	<u>OOMFIE</u>	<u>SEFIE</u>	<u>COFAIE</u>	<u>LOFIE</u>	<u>RAIIE</u>	<u>AISIE</u>	<u>OOFIE</u>	<u>LOSIE</u>
				Reserved	Reserved	Reserved	Reserved	<u>T3FMIE</u>	<u>AICIE</u>	<u>IDLEIE</u>	<u>RUA1IE</u>
K2E	K2E K2F	T3.RSRIE2	RW	--	--	--	--	<u>CPECIE</u>	<u>FBECIE</u>	<u>PECIE</u>	<u>FECIE</u>
				--	--	--	--	<u>CPEIE</u>	<u>FBEIE</u>	<u>PEIE</u>	<u>FEIE</u>
K30- K32	K30 K33	RESERVED		--	--	--	--	--	--	--	--
				--	--	--	--	--	--	--	--
K34	K34 K35	T3.RFECR	R	<u>FE7</u>	<u>FE6</u>	<u>FE5</u>	<u>FE4</u>	<u>FE3</u>	<u>FE2</u>	<u>FE1</u>	<u>FE0</u>
				<u>FE15</u>	<u>FE14</u>	<u>FE13</u>	<u>FE12</u>	<u>FE11</u>	<u>FE10</u>	<u>FE9</u>	<u>FE8</u>
K36	K36 K37	T3.RPECR	R	<u>PE7</u>	<u>PE6</u>	<u>PE5</u>	<u>PE4</u>	<u>PE3</u>	<u>PE2</u>	<u>PE1</u>	<u>PE0</u>
				<u>PE15</u>	<u>PE14</u>	<u>PE13</u>	<u>PE12</u>	<u>PE11</u>	<u>PE10</u>	<u>PE9</u>	<u>PE8</u>
K38	K38 K39	T3.RFBECR	R	<u>FBE7</u>	<u>FBE6</u>	<u>FBE5</u>	<u>FBE4</u>	<u>FBE3</u>	<u>FBE2</u>	<u>FBE1</u>	<u>FBE0</u>
				<u>FBE15</u>	<u>FBE14</u>	<u>FBE13</u>	<u>FBE12</u>	<u>FBE11</u>	<u>FBE10</u>	<u>FBE9</u>	<u>FBE8</u>
K3A	K3A K3B	T3.RCPECR	R	<u>CPE7</u>	<u>CPE6</u>	<u>CPE5</u>	<u>CPE4</u>	<u>CPE3</u>	<u>CPE2</u>	<u>CPE1</u>	<u>CPE0</u>
				<u>CPE15</u>	<u>CPE14</u>	<u>CPE13</u>	<u>CPE12</u>	<u>CPE11</u>	<u>CPE10</u>	<u>CPE9</u>	<u>CPE8</u>
K3C- K3E	K3C K3F	UNUSED		--	--	--	--	--	--	--	--
				--	--	--	--	--	--	--	--

12.1.4 E3 G.751 Register Bit Map

Table 12-9. E3 G.751 Register Bit Map

Address		Register	Type	Bit 7	Bit 6	Bit 5	Bit 4	Bit 3	Bit 2	Bit 1	Bit 0
16-bit	8-bit			Bit 15	Bit 14	Bit 13	Bit 12	Bit 11	Bit 10	Bit 9	Bit 8
K18	K18	E3G751.TCR	RW	--	--	Reserved	Reserved	TABC1	TABC0	TFGD	TAIS
	K19			Reserved	--	--	Reserved	Reserved	Reserved	Reserved	TNBC1
K1A	K1A	E3G751.TEIR	RW	Reserved	Reserved	Reserved	FEIC1	FEIC0	FEI	TSEI	MEIMS
	K1B			--	--	--	--	Reserved	Reserved	Reserved	Reserved
K1C- K1E	K1C K1F	RESERVED		--	--	--	--	--	--	--	--
				--	--	--	--	--	--	--	--

Address 16-bit	8-bit	Register	Type	Bit 7	Bit 6	Bit 5	Bit 4	Bit 3	Bit 2	Bit 1	Bit 0
				Bit 15	Bit 14	Bit 13	Bit 12	Bit 11	Bit 10	Bit 9	Bit 8
K20	K20 K21	E3G751.RCR	RW	RAILE	RAILD	RAIOD	RAIAD	ROMD	LIP1	LIP0	FRSYNC
				Reserved	Reserved	DLS	MDAIS1	AAISD	ECC	FECC1	FECC0
K22	K22 K23	RESERVED		--	--	--	--	--	--	--	--
				--	--	--	--	--	--	--	--
K24	K24 K25	E3G751.RSR1	R	<u>RAB</u>	<u>RNB</u>	--	<u>LOF</u>	<u>RAI</u>	<u>AIS</u>	<u>OOF</u>	<u>LOS</u>
				Reserved	Reserved	--	Reserved	Reserved	Reserved	Reserved	Reserved
K26	K26 K27	E3G751.RSR2	R	--	--	--	--	Reserved	Reserved	Reserved	FEC
				--	--	--	--	--	--	--	--
K28	K28 K29	E3G751.RSRL1	RL	<u>ACL</u>	<u>NCL</u>	<u>COFAL</u>	<u>LOFL</u>	<u>RAIL</u>	<u>AISL</u>	<u>OOFL</u>	<u>LOSL</u>
				Reserved	Reserved	Reserved	Reserved	Reserved	Reserved	Reserved	Reserved
K2A	K2A K2B	E3G751.RSRL2	RL	--	--	--	--	Reserved	Reserved	Reserved	FEC
				--	--	--	--	Reserved	Reserved	Reserved	FEL
K2C	K2C K2D	E3G751.RSR1E1	RW	ACIE	NCIE	COFAIE	LOFIE	RAIIE	AISIE	OOFIE	LOSIE
				Reserved	Reserved	Reserved	Reserved	Reserved	Reserved	Reserved	Reserved
K2E	K2E K2F	E3G751.RSR1E2	RW	--	--	--	--	Reserved	Reserved	Reserved	FECIE
				--	--	--	--	Reserved	Reserved	Reserved	FEIE
K30- K32	K30 K33	RESERVED		--	--	--	--	--	--	--	--
				--	--	--	--	--	--	--	--
K34	K34 K35	E3G751.RFECR	R	<u>FE7</u>	<u>FE6</u>	<u>FE5</u>	<u>FE4</u>	<u>FE3</u>	<u>FE2</u>	<u>FE1</u>	<u>FE0</u>
				<u>FE15</u>	<u>FE14</u>	<u>FE13</u>	<u>FE12</u>	<u>FE11</u>	<u>FE10</u>	<u>FE9</u>	<u>FE8</u>
K36- K3A	K36- K3B	RESERVED		--	--	--	--	--	--	--	--
				--	--	--	--	--	--	--	--
K3C- K3E	K3C- K3F	UNUSED		--	--	--	--	--	--	--	--
				--	--	--	--	--	--	--	--

12.1.5 E3 G.832 Register Bit Map

Table 12-10. E3 G.832 Register Bit Map

Address 16-bit	8-bit	Register	Type	Bit 7	Bit 6	Bit 5	Bit 4	Bit 3	Bit 2	Bit 1	Bit 0
				Bit 15	Bit 14	Bit 13	Bit 12	Bit 11	Bit 10	Bit 9	Bit 8
K18	K18 K19	E3G832.TCR	RW	--	--	TFEBE	AFEBED	TRDI	ARDID	TFGD	TAIS
				Reserved	--	--	Reserved	Reserved	TGCC	TNRC1	TNRC0
K1A	K1A K1B	E3G832.TEIR	RW	PBEE	CPEIE	PEI	FEIC1	FEIC0	FEI	TSEI	MEIMS
				--	--	--	--	Reserved	Reserved	CFBEIE	FBEI
K1C	K1C K1D	E3G832.TMABR	RW	TPT2	TPT1	TPT0	TTIGD	TTI3	TTI2	TTI1	TTI0
				--	--	--	--	--	--	--	--
K1E	K1E K1F	E3G832.TNGBR	RW	TNR7	TNR6	TNR5	TNR4	TNR3	TNR2	TNR1	TNR0
				TGC7	TGC6	TGC5	TGC4	TGC3	TGC2	TGC1	TGC0
K20	K20 K21	E3G832.RCR	RW	RDILE	RDILD	RDIOD	RDIAD	ROMD	LIP1	LIP0	FRSYNC
				Reserved	PEC	DLS	MDAIS1	AAISD	ECC	FECC1	FECC0
K22	K22 K23	E3G832.RMACR	RW	--	--	--	--	EPT2	EPT1	EPT0	TIED
				--	--	--	--	--	--	--	--
K24	K24 K25	E3G832.RSR1	R	Reserved	Reserved	--	<u>LOF</u>	<u>RAI</u>	<u>AIS</u>	<u>OOF</u>	<u>LOS</u>
				Reserved	--	--	<u>RPTU</u>	<u>RPTM</u>	Reserved	Reserved	<u>RUA1</u>
K26	K26 K27	E3G832.RSR2	R	--	--	--	--	Reserved	<u>FBEC</u>	<u>PEC</u>	<u>FEC</u>
				--	--	--	--	--	--	--	--
K28	K28 K29	E3G832.RSRL1	RL	<u>GCL</u>	<u>NRL</u>	<u>COFAL</u>	<u>LOFL</u>	<u>RAIL</u>	<u>AISL</u>	<u>OOFL</u>	<u>LOSL</u>
				Reserved	--	<u>TIL</u>	<u>RPTUL</u>	<u>RPTML</u>	<u>RPTL</u>	Reserved	<u>RUA1L</u>

Address 16-bit	8-bit	Register	Type	Bit 7	Bit 6	Bit 5	Bit 4	Bit 3	Bit 2	Bit 1	Bit 0
				Bit 15	Bit 14	Bit 13	Bit 12	Bit 11	Bit 10	Bit 9	Bit 8
K2A	K2A K2B	E3G832.RSRL2	RL	--	--	--	--	Reserved	<u>FBECL</u>	<u>PECL</u>	<u>FECL</u>
				--	--	--	--	Reserved	<u>FBEL</u>	<u>PEL</u>	<u>FEL</u>
K2C	K2C K2D	E3G832.RSRIE1	RW	GCIE	NRIE	COFAIE	LOFIE	RAIIE	AISIE	OOFIE	LOSIE
				Reserved	--	TIIE	RPTUIE	RPTMIE	RPTIE	Reserved	RUA1IE
K2E	K2E K2F	E3G832.RSRIE2	RW	--	--	--	--	Reserved	<u>FBECIE</u>	<u>PECIE</u>	<u>FECIE</u>
				--	--	--	--	Reserved	<u>FBEIE</u>	<u>PEIE</u>	<u>FEIE</u>
K30	K30 K31	E3G832.RMABR	R	--	<u>RPT2</u>	<u>RPT1</u>	<u>RPT0</u>	<u>TI3</u>	<u>TI2</u>	<u>TI1</u>	<u>TI0</u>
				--	--	--	--	--	--	--	--
K32	K32 K33	E3G832.RNGBR	R	<u>RNR7</u>	<u>RNR6</u>	<u>RNR5</u>	<u>RNR4</u>	<u>RNR3</u>	<u>RNR2</u>	<u>RNR1</u>	<u>RNR0</u>
				<u>RGC7</u>	<u>RGC6</u>	<u>RGC5</u>	<u>RGC4</u>	<u>RGC3</u>	<u>RGC2</u>	<u>RGC1</u>	<u>RGC0</u>
K34	K34 K35	E3G832.RFECR	R	<u>FE7</u>	<u>FE6</u>	<u>FE5</u>	<u>FE4</u>	<u>FE3</u>	<u>FE2</u>	<u>FE1</u>	<u>FE0</u>
				<u>FE15</u>	<u>FE14</u>	<u>FE13</u>	<u>FE12</u>	<u>FE11</u>	<u>FE10</u>	<u>FE9</u>	<u>FE8</u>
K36	K36 K37	E3G832.RPECR	R	<u>PE7</u>	<u>PE6</u>	<u>PE5</u>	<u>PE4</u>	<u>PE3</u>	<u>PE2</u>	<u>PE1</u>	<u>PE0</u>
				<u>PE15</u>	<u>PE14</u>	<u>PE13</u>	<u>PE12</u>	<u>PE11</u>	<u>PE10</u>	<u>PE9</u>	<u>PE8</u>
K38	K38 K39	E3G832.RFBER	R	<u>FBE7</u>	<u>FBE6</u>	<u>FBE5</u>	<u>FBE4</u>	<u>FBE3</u>	<u>FBE2</u>	<u>FBE1</u>	<u>FBE0</u>
				<u>FBE15</u>	<u>FBE14</u>	<u>FBE13</u>	<u>FBE12</u>	<u>FBE11</u>	<u>FBE10</u>	<u>FBE9</u>	<u>FBE8</u>
K3A	K3A K3B	RESERVED		--	--	--	--	--	--	--	--
				--	--	--	--	--	--	--	--
K3C- K3E	K3C- K3F	UNUSED		--	--	--	--	--	--	--	--
				--	--	--	--	--	--	--	--

12.1.6 Clear Channel Register Bit Map

Table 12-11. Clear Channel Register Bit Map

Address 16-bit	8-bit	Register	Type	Bit 7	Bit 6	Bit 5	Bit 4	Bit 3	Bit 2	Bit 1	Bit 0
				Bit 15	Bit 14	Bit 13	Bit 12	Bit 11	Bit 10	Bit 9	Bit 8
K18	K18 K19	CC.TCR	RW	--	--	Reserved	Reserved	Reserved	Reserved	Reserved	TAIS
				Reserved	--	--	Reserved	Reserved	Reserved	Reserved	Reserved
K1A- K1E	K1A K1F	RESERVED		--	--	--	--	--	--	--	--
				--	--	--	--	--	--	--	--
K20	K20 K21	CC.RCR	RW	Reserved	Reserved	Reserved	Reserved	Reserved	Reserved	Reserved	Reserved
				Reserved	Reserved	Reserved	MDAIS1	AAISD	Reserved	Reserved	Reserved
K22	K22 K23	RESERVED		--	--	--	--	--	--	--	--
				--	--	--	--	--	--	--	--
K24	K24 K25	CC.RSR1	R	<u>Reserved</u>	<u>Reserved</u>	--	<u>Reserved</u>	<u>Reserved</u>	<u>Reserved</u>	<u>Reserved</u>	<u>LOS</u>
				<u>Reserved</u>	<u>Reserved</u>	--	<u>Reserved</u>	<u>Reserved</u>	<u>Reserved</u>	<u>Reserved</u>	<u>RUA1</u>
K26	K26 K27	RESERVED		--	--	--	--	--	--	--	--
				--	--	--	--	--	--	--	--
K28	K28 K29	CC.RSRL1	RL	<u>Reserved</u>	<u>Reserved</u>	<u>Reserved</u>	<u>Reserved</u>	<u>Reserved</u>	<u>Reserved</u>	<u>Reserved</u>	<u>LOSL</u>
				<u>Reserved</u>	<u>Reserved</u>	<u>Reserved</u>	<u>Reserved</u>	<u>Reserved</u>	<u>Reserved</u>	<u>Reserved</u>	<u>RUA1L</u>
K2A	K2A K2B	RESERVED		--	--	--	--	--	--	--	--
				--	--	--	--	--	--	--	--
K2C	K2C K2D	CC.RSRIE1	RW	Reserved	Reserved	Reserved	Reserved	Reserved	Reserved	Reserved	LOSIE
				Reserved	Reserved	Reserved	Reserved	Reserved	Reserved	Reserved	RUA1IE
K2E- K3A	K2E- K3B	RESERVED		--	--	--	--	--	--	--	--
				--	--	--	--	--	--	--	--
K3C- K3E	K3C- K3F	UNUSED		--	--	--	--	--	--	--	--
				--	--	--	--	--	--	--	--

Bits that are underlined are read-only; all other bits are read-write.

12.2 Global Registers

Table 12-12. Global Register Map

Address	Register	Register Description
000h	GL.IDR	Global ID Register
002h	GL.CR1	Global Control Register 1
004h	GL.CR2	Global Control Register 2
006h	--	Unused
008h	--	Unused
00Ah	GL.GIOCR	Global General-Purpose IO Control Register
00Ch	--	Unused
00Eh	--	Unused
010h	GL.ISR	Global Interrupt Status Register
012h	GL.ISRIE	Global Interrupt Enable Register
014h	GL.SR	Global Status Register
016h	GL.SRL	Global Status Register Latched
018h	GL.SRIE	Global Status Register Interrupt Enable
01Ah	--	Unused
01Ch	GL.GIORR	Global General-Purpose IO read register
01Eh	--	Unused

12.2.1 Register Bit Descriptions

Register Name: **GL.IDR**
 Register Description: **Global ID Register**
 Register Address: **000h**

Bit #	15	14	13	12	11	10	9	8
Name	<u>ID15</u>	<u>ID14</u>	<u>ID13</u>	<u>ID12</u>	<u>ID11</u>	<u>ID10</u>	<u>ID9</u>	<u>ID8</u>

Bit #	7	6	5	4	3	2	1	0
Name	<u>ID7</u>	<u>ID6</u>	<u>ID5</u>	<u>ID4</u>	<u>ID3</u>	<u>ID2</u>	<u>ID1</u>	<u>ID0</u>

Bits 15 to 12: Device REV ID Bits 15 to 12 (ID15 to ID12). These bits of the device ID register has same information as the four bits of JTAG REV ID portion of the JTAG ID register. JTAG ID[31:28].

Bits 11 to 0: Device CODE ID Bits 11 to 0 (ID11 to ID0). These bits of the device code ID register has same information as the lower 12 bits of JTAG CODE ID portion of the JTAG ID register. JTAG ID[23:12].

Register Name: **GL.CR1**
 Register Description: **Global Control Register 1**
 Register Address: **002h**

Bit #	15	14	13	12	11	10	9	8
Name	GWRM	INTM	RESERVED	--	RESERVED	RESERVED	RESERVED	RESERVED
Default	0	0	0	0	0	0	0	0

Bit #	7	6	5	4	3	2	1	0
Name	TMEI	MEIMS	GPM1	GPM0	PMU	LSBCRE	RSTD P	RST
Default	0	0	0	0	0	0	1	0

Bit 15: Global Write Mode (GWRM) This bit enables the global write mode. When this bit is set, a write to the register of any port will write to the same register in all the ports. Reading the registers of any port is not supported and will read back undefined data.

0 = Normal write mode

1 = Global write mode

Bit 14: $\overline{\text{INT}}$ pin mode (INTM) This bit determines the inactive mode of the $\overline{\text{INT}}$ pin. The $\overline{\text{INT}}$ pin always drives low when active.

0 = Pin is high impedance when not active

1 = Pin drives high when not active

Bit 7: Transmit Manual Error Insert (TMEI) This bit is used insert an error in all ports configured for global error insertion. An error(s) is inserted at the next opportunity when this bit transitions from low to high. The [GL.CR1](#).MEIMS bit must be clear for this bit to operate.

Bit 6: Transmit Manual Error Insert Select (MEIMS) This bit is used to select the source of the global manual error insertion signal

0 = Global error insertion using TMEI bit

1 = Global error insertion using the GPIO6 pin

Bits 5 and 4: Global Performance Monitor Update Mode (GPM[1:0]) These bits select the global performance monitor register update mode.

00 = Global PM update using the PMU bit

01 = Global PM update using the GPIO8 pin

1x = One second PM update using the internal one second counter

Bit 3: Global Performance Monitor Update Register (PMU) This bit is used to update all of the performance monitor registers configured to use this bit. When this bit is toggled from low to high the performance registers configured to use this signal will be updated with the latest count value from the counters, and the counters will be reset. The bit should remain high until the performance register update status bit ([GL.SR](#).PMS) goes high, then it should be brought back low which clears the PMS status bit.

Bit 2: Latched Status Bit Clear on Read Enable (LSBCRE). This signal determines when latched status register bits are cleared.

0 = Latched status register bits are cleared on a write

1 = Latched status register bits are cleared on a read

Bit 1: Reset Data Path (RSTD P). When this bit is set, it will force all of the internal data path registers in all ports to their default state. This bit must be set high for a minimum of 100ns. See the [Reset and Power-Down](#) section in Section [10.3](#). Note: The default state is a 1 (after a general reset, this bit will be set to one).

0 = Normal operation

1 = Force all data path registers to their default values

Bit 0: Reset (RST). When this bit is set, all of the internal data path and status and control registers (except this RST bit), on all of the ports, will be reset to their default state. This bit must be set high for a minimum of 100ns. See the [Reset and Power-Down](#) section in Section [10.3](#).

0 = Normal operation

1 = Force all internal registers to their default values

Register Name: **GL.CR2**
 Register Description: **Global Control Register 2**
 Register Address: **004h**

Bit #	15	14	13	12	11	10	9	8
Name	--	--	--	G8KRS2	G8KRS1	G8KRS0	G8K0S	G8KIS
Default	0	0	0	0	0	0	0	0

Bit #	7	6	5	4	3	2	1	0
Name	--	--	--	--	CLAD3	CLAD2	CLAD1	CLAD0
Default	0	0	0	0	0	0	0	0

Bits 12 to 10: Global 8KHz Reference Source [2:0] (G8KRS[2:0]). These bits determine the source for the internally generated 8 kHz reference as well as the internal one second reference, which is derived from the Global 8 kHz reference. The source is selected from one of the CLAD clocks or from one of the port 8KREF clock sources. These bits are ignored when the G8KIS bit = 1. See [Table 10-12](#).

Bit 9: Global 8KHz Reference Output Select (G8K0S). This bit determines whether GPIO2 pin is used for the global 8KREFO output signal, or is used as specified by [GL.GIOCR.GPIO2S\[1:0\]](#).

0 = GPIO2 pin mode selected by [GL.GIOCR.GPIO2S\[1:0\]](#)

1 = GPIO2 is the global 8KREFO output signal selected by [GL.CR2.8KRS\[2:0\]](#)

Bit 8: Global 8KHz Reference Input Select (G8KIS). This bit determines whether GPIO4 pin is used for the global 8KREFI input signal, or is used as specified by [GL.GIOCR.GPIO4S\[1:0\]](#). G8KREFI signal will be low if not selected. Global 8KREF pin signal will be low if not selected.

0 = GPIO4 pin mode selected by [GL.GIOCR.GPIO4S\[1:0\]](#)

1 = GPIO4 is the global 8KREFI input signal for one second timer and ports to use

Bits 3 to 0: CLAD IO Mode [3:0] (CLAD[3:0]). These bits control the CLAD clock IO pins CLKA, CLKB and CLKC. Note: These bits control which clock is used to recover the RX Clock from the line in the LIU. See [Table 10-11](#).

Register Name: **GL.GIOCR**
 Register Description: **Global General-Purpose IO Control Register**
 Register Address: **00Ah**

Bit #	15	14	13	12	11	10	9	8
Name	GPIO8S1	GPIO8S0	GPIO7S1	GPIO7S0	GPIO6S1	GPIO6S0	GPIO5S1	GPIO5S0
Default	0	0	0	0	0	0	0	0

Bit #	7	6	5	4	3	2	1	0
Name	GPIO4S1	GPIO4S0	GPIO3S1	GPIO3S0	GPIO2S1	GPIO2S0	GPIO1S1	GPIO1S0
Default	0	0	0	0	0	0	0	0

Bits 15 to 14: General-Purpose IO 8 Select [1:0] (GPIO8S[1:0]). These bits determine the function of the GPIO8 pin. These selections are only valid if **GL.CR1.GPM[1:0]** is not set to 01.

- 00 = Input
- 01 = Port 4 B status output selected by [PORT.CR4:GPIOB\[3:0\]](#) in port control registers
- 10 = Output logic 0
- 11 = Output logic 1

Bits 13 to 12: General-Purpose IO 7 Select [1:0] (GPIO7S[1:0]). These bits determine the function of the GPIO7 pin.

- 00 = Input
- 01 = Port 4 A status output selected by [PORT.CR4:GPIOA\[3:0\]](#) in port control registers
- 10 = Output logic 0
- 11 = Output logic 1

Bits 11 to 10: General-Purpose IO 6 Select [1:0] (GPIO6S[1:0]). These bits determine the function of the GPIO6 pin. These selections are only valid if **GL.CR1.MEIMS=0**.

- 00 = Input
- 01 = Port 3 B status output selected by [PORT.CR4:GPIOB\[3:0\]](#) in port control registers
- 10 = Output logic 0
- 11 = Output logic 1

Bits 9 to 8: General-Purpose IO 5 Select [1:0] (GPIO5S[1:0]). These bits determine the function of the GPIO5 pin.

- 00 = Input
- 01 = Port 3 A status output selected by [PORT.CR4:GPIOA\[3:0\]](#) in port control registers
- 10 = Output logic 0
- 11 = Output logic 1

Bits 7 to 6: General-Purpose IO 4 Select [1:0] (GPIO4S[1:0]). These bits determine the function of the GPIO4 pin. These selections are only valid if **GL.CR2.G8KRIS=0**.

- 00 = Input
- 01 = Port 2 B status output selected by [PORT.CR4:GPIOB\[3:0\]](#) in port control registers
- 10 = Output logic 0
- 11 = Output logic 1

Bits 5 to 4: General-Purpose IO 3 Select [1:0] (GPIO3S[1:0]). These bits determine the function of the GPIO3 pin.

- 00 = Input
- 01 = Port 2 A status output selected by [PORT.CR4:GPIOA\[3:0\]](#) in port control registers
- 10 = Output logic 0
- 11 = Output logic 1

Bits 3 to 2: General-Purpose IO 2 Select [1:0] (GPIO2S[1:0]). These bits determine the function of the GPIO2 pin. These selections are only valid if **GL.CR2.GKROS=0**.

- 00 = Input
- 01 = Port 1 B status output selected by [PORT.CR4:GPIOB\[3:0\]](#) in port control registers
- 10 = Output logic 0

11 = Output logic 1

Bits 1 to 0: General-Purpose IO 1 Select [1:0] (GPIO1S[1:0]). These bits determine the function of the GPIO1 pin.

00 = Input

01 = Port 1 A status output selected by [PORT.CR4](#):GPIOA[3:0] in port control registers

10 = Output logic 0

11 = Output logic 1

Register Name: **GL.ISR**
 Register Description: **Global Interrupt Status Register**
 Register Address: **010h**

Bit #	15	14	13	12	11	10	9	8
Name	--	--	--	--	--	--	--	--
Bit #	7	6	5	4	3	2	1	0
Name	PISR4	PISR3	PISR2	PISR1	--	--	RESERVED	GSR

Bits 7 to 4: Port Interrupt Status Register [4:1] (PISR[4:1]) The corresponding bit is set when any of the bits in the port interrupt status registers ([PORT.ISR](#)) are set. The \overline{INT} interrupt pin will be driven low when any bit is set and the corresponding [GL.ISRIE](#).PISRIE[4:1] interrupt enable bit is enabled.

Bit 0: Global Status Register Interrupt Status (GSR) This bit is set when any of the latched status register bits in the global latched status register ([GL.SRL](#)) are set and enabled for interrupt. The \overline{INT} interrupt pin will be driven low when this bit is set and the [GL.ISRIE](#).GSRIE interrupt enable bit is enabled.

Register Name: **GL.ISRIE**
 Register Description: **Global Interrupt Status Register Interrupt Enable**
 Register Address: **012h**

Bit #	15	14	13	12	11	10	9	8
Name	--	--	--	--	--	--	--	--
Default	0	0	0	0	0	0	0	0
Bit #	7	6	5	4	3	2	1	0
Name	PISRIE4	PISRIE3	PISRIE2	PISRIE1	--	--	RESERVED	GSRIE
Default	0	0	0	0	0	0	0	0

Bits 7 to 4: Port Interrupt Status Register Interrupt Enable [4:1] (PISRIE[4:1]) When any interrupt enable bit in this group is enabled corresponding to a status bit set in the [GL.ISR](#).PISR[4:1] status bit group, the \overline{INT} pin will be driven low.

0 = interrupt disabled

1 = interrupt enabled

Bit 0: Global Status Register Interrupt Status Interrupt Enable (GSRIE) When this interrupt enable bit is enabled, and the [GL.ISR](#).GSR status bit is set, the \overline{INT} pin will be driven low.

0 = interrupt disabled

1 = interrupt enabled

Register Name: **GL.SR**
 Register Description: **Global Status Register**
 Register Address: **014h**

Bit #	15	14	13	12	11	10	9	8
Name	--	--	--	--	--	--	--	--
Bit #	7	6	5	4	3	2	1	0
Name	--	--	--	--	--	--	CLOL	GPMS

Bit 1 : CLAD Loss of Lock (CLOL) – This bit is set when any of the PLLs in the CLAD are not locked to the reference frequency.

Bit 0: Global Performance Monitoring Update Status (GPMS) This bit is set when all of the port performance register update status bits (*PORT.SR.PMS*), that are enabled for global update control (*PORT.CR1.PMUM=1*), are set. It is an “AND” of all the globally enabled port PMU status bits. In global software update mode, the global update request bit (*GL.CR1.GPMU*) should be held high until this status bit goes high.

0 = The associated update request signal is low or not all register updates are completed

1 = The requested performance register updates are all completed

Register Name: **GL.SRL**
 Register Description: **Global Status Register Latched**
 Register Address: **016h**

Bit #	15	14	13	12	11	10	9	8
Name	--	--	--	--	--	--	--	--
Bit #	7	6	5	4	3	2	1	0
Name	--	--	--	8KREFL	CLADL	ONESL	CLOLL	GPMSL

Bit 4: 8K Reference Activity Status Latched (8KREFL) This bit will be set when the 8 kHz reference signal on the GPIO4 pin is active. The [GL.CR2.G8KIS](#) bit must be set for the activity to be monitored.

Bit 3: CLAD Reference Clock Activity Status Latched (CLADL) This bit will be set when the CLAD PLL reference clock signal on the CLKA pin is active.

Bit 2: One Second Status Latched (ONESL) This bit will be set once a second. The [GL.ISR.GSR](#) status bit will be set when this bit is set and the [GL.SRIE.ONESIE](#) bit is enabled. The $\overline{\text{INT}}$ pin will be driven low if this bit is set and the [GL.SRIE.ONESIE](#) bit and the [GL.ISRIE.GSRIE](#) bit are enabled.

Bit 1: CLAD Loss Of Lock Latched (CLOLL) This bit will be set when the *GL.SR.CLOL* status bit changes from low to high. The *GL.ISR.GSR* bit will be set when this bit is set and the *GL.SRIE.CLOLIE* bit is set and the $\overline{\text{INT}}$ pin will be driven low if the *GL.ISRIE.GSRIE* bit is also enabled.

Bit 0: Global Performance Monitoring Update Status Latched (GPMSL) This bit will be set when the [GL.SR.GPMS](#) status bit changes from low to high. This bit will set the [GL.ISR.GSR](#) status bit if the [GL.SRIE.GPMSIE](#) is enabled. This bit will drive the interrupt pin low if the [GL.SRIE.GPMSIE](#) bit and the [GL.ISRIE.GSRIE](#) bit are enabled.

Register Name: **GL.SRIE**
 Register Description: **Global Status Register Interrupt Enable**
 Register Address: **018h**

Bit #	15	14	13	12	11	10	9	8
Name	--	--	--	--	--	--	--	--
Default	0	0	0	0	0	0	0	0

Bit #	7	6	5	4	3	2	1	0
Name	--	--	--	--	--	ONESIE	CLOLIE	GPMSIE
Default	0	0	0	0	0	0	0	0

Bit 2: One Second Interrupt Enable (ONESIE) This bit will drive the interrupt pin low when this bit is enabled the [GL.SRL](#).ONESL bit is set, and the [GL.ISRIE](#).GSRIE bit is enabled.

0 = interrupt disabled
 1 = interrupt enabled

Bit 1: CLAD Loss Of Lock Interrupt Enable (CLOLIE) The interrupt pin will be driven when this bit is enabled, the [GL.SRL](#).CLOLL is set, and [GL.ISRIE](#).GSRIE bit is enabled.

0 = interrupt disabled
 1 = interrupt enabled

Bit 0: Global Performance Monitoring Update Status Interrupt Enable (GPMSIE) The interrupt pin will be driven when this bit is enabled and the [GL.SRL](#).GPMSL bit is set and the [GL.ISRIE](#).GSRIE bit is enabled.

0 = interrupt disabled
 1 = interrupt enabled

Register Name: **GL.GIORR**
 Register Description: **Global General-Purpose IO Read Register**
 Register Address: **01Ch**

Bit #	15	14	13	12	11	10	9	8
Name	--	--	--	--	--	--	--	--

Bit #	7	6	5	4	3	2	1	0
Name	<u>GPIO8</u>	<u>GPIO7</u>	<u>GPIO6</u>	<u>GPIO5</u>	<u>GPIO4</u>	<u>GPIO3</u>	<u>GPIO2</u>	<u>GPIO1</u>

Bits 7 to 0: General-Purpose IO Status [8:1] (GPIO[8:1]) These bits reflect the input or output signal on the 8 general-purpose IO pins.

12.3 Per Port Common

12.3.1 Register Bit Descriptions

Table 12-13. Per Port Common Register Map

Address	Register	Register Description
(0,2,4,6)40h	PORT.CR1	Port Control Register 1
(0,2,4,6)42h	PORT.CR2	Port Control Register 2
(0,2,4,6)44h	PORT.CR3	Port Control Register 3
(0,2,4,6)46h	PORT.CR4	Port Control Register 4
(0,2,4,6)48h	--	Unused
(0,2,4,6)4Ah	PORT.INV1	Port IO Invert Control Register 1
(0,2,4,6)4Ch	PORT.INV2	Port IO Invert Control Register 2
(0,2,4,6)4Eh	--	Unused
(0,2,4,6)50h	PORT.ISR	Port Interrupt Status Register
(0,2,4,6)52h	PORT.SR	Port Status Register
(0,2,4,6)54h	PORT.SRL	Port Status Register Latched
(0,2,4,6)56h	PORT.SRIE	Port Status Register Interrupt Enable
(0,2,4,6)58h	--	Unused
(0,2,4,6)5Ah	--	Unused
(0,2,4,6)5Ch	--	Unused
(0,2,4,6)5Eh	--	Unused

Register Name: **PORT.CR1**
 Register Description: **Port Control Register 1**
 Register Address: **(0,2,4,6)40h**

Bit #	15	14	13	12	11	10	9	8
Name	RESERVED	PAIS2	PAIS1	PAIS0	LAIS1	LAIS0	BENA	RESERVED
Default	0	0	0	0	0	0	0	0

Bit #	7	6	5	4	3	2	1	0
Name	TMEI	MEIM	--	PMUM	PMU	PD	RSTDP	RST
Default	0	0	--	0	0	1	1	0

Bits 14 to 12: Payload AIS Select [2:0] (PAIS[2:0]). This bit controls when an unframed all ones signal is forced on the receive data path after the receive framer and payload loopback mux. Default: Payload AIS always sent. See [Table 10-19](#).

Bits 11 to 10: Line AIS Select [1:0] (LAIS[1:0]). These bits control when a DS3 framed AIS or an unframed all ones signal is to be transmitted on TPOSn/TNEGn and/or TXPn/TXNn. The signal on TPOSn/TNEGn can be AMI or unipolar. This signal is sent even when in diagnostic loopback and always over-rides signals from the framers. Default: AIS sent if DLB is enabled. See [Table 10-18](#).

Bit 9: BERT Enable (BENA). This bit is used to enable the BERT logic. The BERT pattern will be the payload data replacing the data from the TSERn pin.

- 0 = BERT logic disabled and powered down
- 1 = BERT logic enabled

Bit 7: Transmit Manual Error Insert (TMEI) This bit is used to insert errors in all error insertion logic configured to use this bit when *PORT.CR1.MEIM*=0. The error(s) will be inserted when this bit is toggled low to high.

Bit 6: Transmit Manual Error Insert Mode (MEIM). These bits select the method transmit manual error insertion for this port for error generators configured to use the external TMEI signal. The global updates are controlled by the *GL.CR1.MEIMS* bit.

- 0 = Port software update via *PORT.CR1.TMEI*
- 1 = Global update source

Bit 4: Performance Monitor Update Mode (PMUM). These bits select the method of updating the performance monitor registers. The global updates are controlled by the *GL.CR1.GPM[1:0]* bits.

- 0 = Port software update
- 1 = Global update

Bit 3: Performance Monitor Register Update (PMU) This bit is used to update all of the performance monitor registers configured to use this bit when *PORT.CR1.PMUM*=0. The performance registers configured to use this signal will be updated with the latest count value and the counters reset when this bit is toggled low to high. The bit should remain high until the performance register update status bit (*PORT.SR.PMS*) goes high, then it should be brought back low which clears the PMS status bit.

Bit 2: Power-Down (PD). When this bit is set, the LIU and digital logic for this port are powered down and considered "out of service." The logic is powered down by stopping the clocks. See the [Reset and Power-Down](#) section in Section [10.3](#).

- 0 = Normal operation
- 1 = Power-down port circuits (default state)

Bit 1: Reset Data Path (RSTDP). When this bit is set, it will force all of the internal data path registers in this port to their default state. This bit must be set high for a minimum of 100ns and then set back low. See the [Reset and Power-Down](#) section in Section [10.3](#). Note: The Default State of this bit is 1 (after a general reset (port or global), this bit will be set to one).

- 0 = Normal operation
- 1 = Force all data path registers to their default values

Bit 0: Reset (RST). When this bit is set, it will force all the internal data path and status and control registers (except this RST bit) of this port to their default state. See the [Reset and Power-Down](#) section in Section [10.3](#). This

bit must be set high for a minimum of 100ns and then set back low. This software bit is logically ORed with the inverted hardware signal \overline{RST} and the [GL.CR1.RST](#) bit.

0 = Normal operation

1 = Force all internal registers to their default values

Register Name: **PORT.CR2**
 Register Description: **Port Control Register 2**
 Register Address: **(0,2,4,6)42h**

Bit #	15	14	13	12	11	10	9	8
Name	TLEN	TTS	RMON	TLBO	RESERVED	LM2	LM1	LM0
Default	0	0	0	0	0	0	0	0

Bit #	7	6	5	4	3	2	1	0
Name	RESERVED	RESERVED	FM2	FM1	FM0	RESERVED	RESERVED	RESERVED
Default	0	0	0	0	0	0	0	0

Bit 15: Transmit Line IO Signal Enable (TLEN). This bit is used to enable to transmit line interface output pins TLCLKn, TPOSn/TDATn and TNEGn.

0 = Disable, force outputs low

1 = Enable normal operation

Bit 14: Transmit LIU Tri-State (TTS) This bit is used to tri-state the transmit TXPn and TXNn pins. The LIU is still powered up when the pins are tri-stated. It has no effect when the LIU is disabled and powered down.

0 = TXPn and TXNn driven

1 = TXPn and TXNn tri-stated

Bit 13: Receive LIU Monitor Mode (RMON) This bit is used to enable the receive LIU monitor mode pre-amplifier. Enabling the pre-amplifier adds about 20 dB of linear amplification for use in monitor applications where the signal has been reduced 20 dB using resistive attenuator circuits.

0 = Disable the 20 dB pre-amp

1 = Enable the 20 dB pre-amp

Bit 12: Transmit LIU LBO (TLBO) This bit is used enable the transmit LBO circuit which causes the transmit signal to have a wave shape that approximates about 225 feet of cable. This is used to reduce near end crosstalk when the cable lengths are short. This signal is only valid in DS3 LIU mode.

0 = TXPn and TXNn have full amplitude signals

1 = TXPn and TXNn signals approximate 225 feet of cable

Bits 10 to 8: Port Interface Mode (LM[2:0]). The LM[2:0] bits select main port interface operational modes. The default state disables the LIU and the JA. See Table 10-26.

Bits 5 to 3: Framing Mode (FM[2:0]). The FM[2:0] bits select main framing operational modes. Default: DS3 C-bit. See [Table 10-25](#).

Register Name: **PORT.CR3**
 Register Description: **Port Control Register 3**
 Register Address: **(0,2,4,6)44h**

Bit #	15	14	13	12	11	10	9	8
Name	--	--	RCLKS	RSOFOS	RESERVED	TCLKS	TSOFOS	RESERVED
Default	0	0	0	0	0	0	0	0

Bit #	7	6	5	4	3	2	1	0
Name	P8KRS1	P8KRS0	P8KREF	LOOP	CLADC	RFTS	TFTS	TLTS
Default	0	0	0	0	0	0	0	0

Bit 13: Receive Clock Output Select (RCLKS). This bit is used to select the function of the RGCLKn / RCLKOn pins. See [Table 10-24](#).

- 0 = Selects the RGCLKn signal, or the drive low pin function.
- 1 = Selects RCLKOn signal.

Bit 12: Receive Start Of Frame Output Select (RSOFOS). This bit is to select the function of the RSOFO n / RDENn pins. See [Table 10-23](#).

- 0 = Selects RDENn signal.
- 1 = Selects RSOFO n signal.

Bit 10: Transmit Clock Output Select (TCLKS). This bit is used to select the function of the TGCLKn / TCLKOn pins. See [Table 10-22](#).

- 0 = Selects TGCLKn signal.
- 1 = Selects TCLKOn signal.

Bit 9: Transmit Start Of Frame Output Select (TSOFOS). This bit is used to select the function of the TSOFO n / TDENn pins. See [Table 10-21](#).

- 0 = Selects TDENn signal.
- 1 = Selects TSOFO n signal.

Bits 7 to 6: Port 8 kHz Reference Source Select (P8KRS[1:0]). This bit selects the source of the 8 kHz reference from the port sources. The 8K reference for this port can be used as the global 8K reference source. See [Table 10-13](#).

Bit 6: Port 8 kHz Reference Source Select (P8KRS). This bit selects the source of the 8 kHz reference from the port sources. The 8K reference for this port can also be used as the global 8K reference source.

- 0 = Selects the receive internal framer clock (based on RLCLKn or RX LIU recovered clock)
- 1 = Selects the transmit internal framer clock (based on TCLKIn or the CLAD clock)

Bit 5: PORT 8 kHz Reference Source (P8KREF). This bit selects the source of the 8 kHz reference for PLCP trailer operation and one second timer.

- 0 = 8 kHz reference from global source
- 1 = 8 kHz reference from this ports selected source

Bit 4: LOOP Time Enable (LOOP). When this bit is set, the port is in loop time mode. The transmit clock is set to the receive clock from the RLCLKn pin or the recovered clock from the LIU or the CLAD clock and the TCLKIn pin is not used. This function of this bit is conditional on other control bits. See [Table 10-4](#) for more details.

- 0 = Normal transmit clock operation
- 1 = Transmit using the receive clock

Bit 3: CLAD Transmit Clock Source Control (CLADC). This bit is used to enable the CLAD clocks as the source of the internal transmit clock. This function of this bit is conditional on other control bits. See [Table 10-4](#) for more details.

- 0 = Use CLAD clocks for the transmit clock as appropriate
- 1 = Do not use CLAD clocks for the transmit clock – (if no loopback is enabled, TCLKIn is the source)

Bit 2: Receive Framer IO Signal Timing Select (RFTS). This bit controls the timing reference for the signals on the receive framer interface IO pins. The pins controlled are RSERn, RSOFO n / RDENn. See [Table 10-8](#) for more details.

- 0 = Use output clocks for timing reference
- 1 = Use input clocks for timing reference

Bit 1: Transmit Framer IO Signal Timing Select (TFTS). This bit controls the timing reference for the signals on the transmit framer interface IO pins. The pins controlled are TSOFn, TSERn, and TSOFO n / TDENn. See [Table 10-7](#) for more details.

- 0 = Use output clocks for timing reference
- 1 = Use input clocks for timing reference

Bit 0: Transmit Line IO Signal Timing Select (TLTS). This bit controls the timing reference for the signals on the transmit line interface IO pins. The pins controlled are TPOSn / TDATn and TNEGn. See [Table 10-6](#) for more details.

- 0 = Use output clocks for timing reference
- 1 = Use input clocks for timing reference

Register Name: **PORT.CR4**
 Register Description: **Port Control Register 4**
 Register Address: **(0,2,4,6)46h**

Bit #	15	14	13	12	11	10	9	8
Name	--	--	--	--	RESERVED	LBM2	LBM1	LBM0
Default	0	0	0	0	0	0	0	0

Bit #	7	6	5	4	3	2	1	0
Name	GPIOB3	GPIOB2	GPIOB1	GPIOB0	GPIOA3	GPIOA2	GPIOA1	GPIOA0
Default	0	0	0	0	0	0	0	0

Bits 10 to 8: Loopback Mode [2:0] (LBM[2:0]). These bits select the loopback modes for analog loopback (ALB), line loopback (LLB), payload loopback (PLB) and diagnostic loopback (DLB). See [Table 10-17](#) for the loopback select codes. Default: No Loopback.

Bits 7 to 4: General-Purpose IO B Output Select[3:0] (GPIOB[3:0]) These bits determine which alarm status signal to output on the GPIO2(port 1), GPIO4(port 2), GPIO6(port 3) or GPIO8(port 4) pins. The GPIO pin must be enabled by setting the bits in the [GL.GIOCR](#) and either [GL.CR1](#) or [GL.CR2](#) registers to output the selected alarm signal. See [Table 10-15](#). See [Table 10-16](#) for the alarm select codes.

Bits 3 to 0: General-Purpose IO A Output Select[3:0] (GPIOA[3:0]) These bits determine which alarm status signal to output on the GPIO1(port 1), GPIO3(port 2), GPIO5(port 3) or GPIO7(port 4) pins. The GPIO pin must be enabled for output by setting the bits in the [GL.GIOCR](#) register. See [Table 10-15](#) for configuration settings. See [Table 10-16](#) for the alarm select codes.

Register Name: **PORT.INV1**
 Register Description: **Port IO Invert Control Register 1**
 Register Address: **(0,2,4,6)4Ah**

Bit #	15	14	13	12	11	10	9	8
Name	RESERVED	RESERVED	--	TSOFOI	RESERVED	TSERI	TOHSI	TOHEI
Default	0	0	0	0	0	0	0	0

Bit #	7	6	5	4	3	2	1	0
Name	TOHI	TOHCKI	TSOFII	TNEGI	TDATI	TLCKI	TCKOI	TCKII
Default	0	0	0	0	0	0	0	0

Bit 12 : TSOFO_n/TDEN_n/Invert (TSOFOI). This bit inverts the TSOFO_n / TDEN_n pin when set.

Bit 10 : TSER_n Invert (TSERI). This bit inverts the TSER_n pin when set.

Bit 9 : TOHSOF_n Invert (TOHSI). This bit inverts the TOHSOF_n pin when set.

Bit 8 : TOHEN_n Invert (TOHEI). This bit inverts the TOHEN_n pin when set.

Bit 7 : TOH_n Invert (TOHI). This bit inverts the TOH_n pin when set.

Bit 6 : TOHCLK_n Invert (TOHCKI). This bit inverts the TOHCLK_n pin when set.

Bit 5 : TSOF_n Invert (TSOFII). This bit inverts the TSOF_n pin when set.

Bit 4 : TNEG_n Invert (TNEGI). This bit inverts the TNEG_n pin when set.

Bit 3 : TDAT_n Invert (TDATI). This bit inverts the TDAT_n pin when set.

Bit 2 : TLCLK_n Invert (TLCKI). This bit inverts the TLCLK_n pin when set.

Bit 1 : TCLK_{On}/TGCLK_n Invert (TCKOI). This bit inverts the TCLK_{On} / TGCLK_n pin when set.

Bit 0 : TCLK_{In} Invert (TCKII). This bit inverts the TCLK_{In} pin when set.

Register Name: **PORT.INV2**
 Register Description: **Port IO Invert Control Register 2**
 Register Address: **(0,2,4,6)4Ch**

Bit #	15	14	13	12	11	10	9	8
Name	--	RESERVED	RESERVED	RSOFOI	--	RSERI	ROHSI	--
Default	0	0	0	0	0	0	0	0

Bit #	7	6	5	4	3	2	1	0
Name	ROHI	ROHCKI	--	RNEGI	RPOSI	RLCKI	RCLKOI	--
Default	0	0	0	0	0	0	0	0

Bit 12 : RSOFOn/RDENn Invert (RSOFOI). This bit inverts the RSOFOn / RDENn pin when set.

Bit 10 : RSERn Invert (RSERI). This bit inverts the RSERn pin when set.

Bit 9 : ROHSOFn Invert (ROHSI). This bit inverts the ROHSOFn pin when set.

Bit 7 : ROHn Invert (ROHI). This bit inverts the ROHn pin when set.

Bit 6 : ROHCLKn Invert (ROHCKI). This bit inverts the ROHCLKn pin when set.

Bit 4 : RNEGn/RLCVn Invert (RNEGI). This bit inverts the RNEGn / RLCVn when set.

Bit 3 : RPOSn/RDATn Invert (RPOSI). This bit inverts the RPOSn / RDATn pin when set.

Bit 2 : RLCLKn Invert (RLCKI). This bit inverts the RLCLKn pin when set.

Bit 1 : RCLKOn / RGCLKn Invert (RCLKOI). This bit inverts the RCLKOn / RGCLKn pin when set.

Register Name: **PORT.ISR**
 Register Description: **Port Interrupt Status Register**
 Register Address: **(0,2,4,6)50h**

Bit #	15	14	13	12	11	10	9	8
Name	--	--	--	--	--	--	<u>PSR</u>	<u>LCSR</u>
Bit #	7	6	5	4	3	2	1	0
Name	<u>TTSR</u>	<u>FSR</u>	<u>HSR</u>	<u>BSR</u>	RESERVED	RESERVED	RESERVED	<u>FMSR</u>

Bit 9: Port Status Register Interrupt Status (PSR) This bit is set when any of the latched status register bits, that are enabled for interrupt, in the *PORT.SRL* register are set. The interrupt pin will be driven when this bit is set and the corresponding [GL.ISRIE.PISRIE\[4:1\]](#) is set.

Bit 8: Line Code Status Register Interrupt Status (LCSR) This bit is set when any of the latched status register bits, that are enabled for interrupt, in the B3ZS/HDB3 Line Encoder/Decoder block are set. The interrupt pin will be driven when this bit is set and the corresponding [GL.ISRIE.PISRIE\[4:1\]](#) is set.

Bit 7: Trail Trace Status Register Interrupt Status (TTSR) This bit is set when any of the latched status register bits, that are enabled for interrupt, in the trail trace block are set. The interrupt pin will be driven when this bit is set and the corresponding [GL.ISRIE.PISRIE\[4:1\]](#) is set.

Bit 6: FEAC Status Register Interrupt Status (FSR) This bit is set when any of the latched status register bits, that are enabled for interrupt, in the FEAC block are set. The interrupt pin will be driven when this bit is set and the corresponding [GL.ISRIE.PISRIE\[4:1\]](#) is set.

Bit 5: HDLC Status Register Interrupt Status (HSR) This bit is set when any of the latched status register bits, that are enabled for interrupt, in the HDLC block are set. The interrupt pin will be driven when this bit is set and the corresponding [GL.ISRIE.PISRIE\[4:1\]](#) is set.

Bit 4: BERT Status Register Interrupt Status (BSR) This bit is set when any of the latched status register bits, that are enabled for interrupt, in the BERT block are set. The interrupt pin will be driven when this bit is set and the corresponding [GL.ISRIE.PISRIE\[4:1\]](#) is set.

Bit 0: Framer Status Register Interrupt Status (FMSR) This bit is set when any of the latched status register bits, that are enabled for interrupt, in the active DS3 or E3 framer block are set. The interrupt pin will be driven when this bit is set and the corresponding [GL.ISRIE.PISRIE\[4:1\]](#) is set.

Register Name: **PORT.SR**
 Register Description: **Port Status Register**
 Register Address: **(0,2,4,6)52h**

Bit #	15	14	13	12	11	10	9	8
Name	--	--	--	--	--	--	--	--
Bit #	7	6	5	4	3	2	1	0
Name	--	--	--	--	--	<u>TDM</u>	<u>RLOL</u>	<u>PMS</u>

Bit 2: Transmit Driver Monitor Status (TDM) This bits indicates the status of the transmit monitor circuit in the transmit LIU.

- 0 = Transmit output not over loaded
- 1 = Transmit signal is overloaded

Bit 1: Receive Loss Of Lock Status (RLOL) This bits indicates the status of the receive LIU clock recovery PLL circuit.

- 0 = Locked to the incoming signal
- 1 = Not locked to the incoming signal

Bit 0: Performance Monitoring Update Status (PMS) This bits indicates the status of all active performance monitoring register and counter update signals in this port. It is an "AND" of all update status bits and is not set until all performance registers are updated and the counters reset. In software update modes, the update request bit PORT.CR1.PMU should be held high until this status bit goes high.

- 0 = The associated update request signal is low
- 1 = The requested performance register updates are all completed

Register Name: **PORT.SRL**
 Register Description: **Port Status Register Latched**
 Register Address: **(0,2,4,6)54h**

Bit #	15	14	13	12	11	10	9	8
Name	--	--	--	--	--	--	--	--
Bit #	7	6	5	4	3	2	1	0
Name	RLCLKA	TCLKIA	--	--	--	TDML	RLOLL	PMSL

Bit 7: Receive Line Clock Activity Status Latched (RLCLKA) This bit will be set when the signal on the RLCLKn pin or the recovered clock from the LIU for this port is active.

Bit 6: Transmit Input Clock Activity Status Latched (TCLKIA) This bit will be set when the signal on the TCLKIn pin for this port is active.

Bit 2: Transmit Driver Monitor Status Latched (TDML) This bit will be set when the *PORT.SR.TDM* status bit changes from low to high. This bit will also set the *PORT.ISR.PSR* status bit if the *PORT.SRIE.TDMIE* bit is enabled. The interrupt pin will be driven when this bit is set, the *PORT.SRIE.TDMIE* bit is set, and the corresponding *GL.ISRIE.PISRIE[4:1]* bit is also set.

Bit 1: Receive Loss Of Lock Status Latched (RLOLL) This bit will be set when the *PORT.SR.RLOL* status bit changes from low to high. This bit will also set the *PORT.ISR.PSR* status bit if the *PORT.SRIE.RLOLIE* bit is enabled. The interrupt pin will be driven when this bit is set, the *PORT.SRIE.RLOLIE* bit is set, and the corresponding *GL.ISRIE.PISRIE[4:1]* bit is also set.

Bit 0: Performance Monitoring Update Status Latched (PMSL) This bit will be set when the *PORT.SR.PMS* status bit changes from low to high. This bit will also set the *PORT.ISR.PSR* status bit if the *PORT.SRIE.PMUIE* bit is enabled. The interrupt pin will be driven when this bit is set, the *PORT.SRIE.PMUIE* bit is set, and the *PORT.SRIE.PMSIE* bit are set.

Register Name: **PORT.SRIE**
 Register Description: **Port Status Register Interrupt Enable**
 Register Address: **(0,2,4,6)56h**

Bit #	15	14	13	12	11	10	9	8
Name	--	--	--	--	--	--	--	--
Default	0	0	0	0	0	0	0	0
Bit #	7	6	5	4	3	2	1	0
Name	--	--	--	--	--	TDMIE	RLOLIE	PMSIE
Default	0	0	0	0	0	0	0	0

Bit 2: Transmit Driver Monitor Latched Status Interrupt Enable (TDMIE) The interrupt pin will be driven when this bit is enabled and the *PORT.SRL.TDML* bit is set and the bit in [GL.ISRIE.PSRIE\[4:1\]](#) that corresponds to this port is enabled.

Bit 1: Receive Loss Of Lock Latched Status Interrupt Enable (RLOLIE) The interrupt pin will be driven when this bit is enabled and the *PORT.SRL.RLOLL* bit is set and the bit in [GL.ISRIE.PSRIE\[4:1\]](#) that corresponds to this port is enabled.

Bit 0: Performance Monitoring Update Latched Status Interrupt Enable (PMSIE) The interrupt pin will be driven when this bit is enabled and the *PORT.SRL.PMSL* bit is set and the bit in [GL.ISRIE.PSRIE\[4:1\]](#) that corresponds to this port is enabled.

12.4 BERT

12.4.1 BERT Register Map

The BERT utilizes 12 registers. Note: The BERT registers will be cleared when GL.CR1.RSTDP or PORT.CR1.RSTDP or PORT.CR1.PD is set.

Table 12-14. BERT Register Map

Address	Register	Register Description
(0,2,4,6)60h	BERT.CR	BERT Control Register
(0,2,4,6)62h	BERT.PCR	BERT Pattern Configuration Register
(0,2,4,6)64h	BERT.SPR1	BERT Seed/Pattern Register #1
(0,2,4,6)66h	BERT.SPR2	BERT Seed/Pattern Register #2
(0,2,4,6)68h	BERT.TEICR	BERT Transmit Error Insertion Control Register
(0,2,4,6)6Ah	--	Unused
(0,2,4,6)6Ch	BERT.SR	BERT Status Register
(0,2,4,6)6Eh	BERT.SRL	BERT Status Register Latched
(0,2,4,6)70h	BERT.SRIE	BERT Status Register Interrupt Enable
(0,2,4,6)72h	--	Unused
(0,2,4,6)74h	BERT.RBECR1	BERT Receive Bit Error Count Register #1
(0,2,4,6)76h	BERT.RBECR2	BERT Receive Bit Error Count Register #2
(0,2,4,6)78h	BERT.RBCR1	BERT Receive Bit Count Register #1
(0,2,4,6)7Ah	BERT.RBCR2	BERT Receive Bit Count Register #2
(0,2,4,6)7Ch	--	Unused
(0,2,4,6)7Eh	--	Unused

12.4.2 BERT Register Bit Descriptions

Register Name: **BERT.CR**
 Register Description: **BERT Control Register**
 Register Address: **(0,2,4,6)60h**

Bit #	15	14	13	12	11	10	9	8
Name	--	--	--	--	--	--	--	--
Default	0	0	0	0	0	0	0	0

Bit #	7	6	5	4	3	2	1	0
Name	PMUM	LPMU	RNPL	RPIC	MPR	APRD	TNPL	TPIC
Default	0	0	0	0	0	0	0	0

Bit 7: Performance Monitoring Update Mode (PMUM) – When 0, a performance monitoring update is initiated by the LPMU register bit. When 1, a performance monitoring update is initiated by the global or port PMU register bit. Note: If the LPMU bit or the global or port PMU bit is one, changing the state of this bit may cause a performance monitoring update to occur.

Bit 6: Local Performance Monitoring Update (LPMU) – This bit causes a performance monitoring update to be initiated if local performance monitoring update is enabled (PMUM = 0). A 0 to 1 transition causes the performance monitoring registers to be updated with the latest data, and the counters reset (0 or 1). For a second performance monitoring update to be initiated, this bit must be set to 0, and back to 1. If LPMU goes low before the PMS bit goes high, an update might not be performed. This bit has no affect when PMUM=1.

Bit 5: Receive New Pattern Load (RNPL) – A zero to one transition of this bit will cause the programmed test pattern (QRSS, PTS, PLF[4:0], PTF[4:0], and BSP[31:0]) to be loaded in to the receive pattern generator. This bit must be changed to zero and back to one for another pattern to be loaded. Loading a new pattern will force the receive pattern generator out of the “Sync” state which causes a resynchronization to be initiated.

Note: QRSS, PTS, PLF[4:0], PTF[4:0], and BSP[31:0] must not change from the time this bit transitions from 0 to 1 until four receive clock cycles after this bit transitions from 0 to 1. Register bit PORT.CR1.BENA must be set and the receive clock running in order for the pattern load to take affect.

Bit 4: Receive Pattern Inversion Control (RPIC) – When 0, the receive incoming data stream is not altered. When 1, the receive incoming data stream is inverted.

Bit 3: Manual Pattern Resynchronization (MPR) – A zero to one transition of this bit will cause the receive pattern generator to resynchronize to the incoming pattern. This bit must be changed to zero and back to one for another resynchronization to be initiated. Note: A manual resynchronization forces the receive pattern generator out of the “Sync” state.

Bit 2: Automatic Pattern Resynchronization Disable (APRD) – When 0, the receive pattern generator will automatically resynchronize to the incoming pattern if six or more times during the current 64-bit window the incoming data stream bit and the receive pattern generator output bit did not match. When 1, the receive pattern generator will not automatically resynchronize to the incoming pattern.

Bit 1: Transmit New Pattern Load (TNPL) – A zero to one transition of this bit will cause the programmed test pattern (QRSS, PTS, PLF[4:0], PTF[4:0], and BSP[31:0]) to be loaded in to the transmit pattern generator. This bit must be changed to zero and back to one for another pattern to be loaded.

Note: QRSS, PTS, PLF[4:0], PTF[4:0], and BSP[31:0] must not change from the time this bit transitions from 0 to 1 until four transmit clock cycles after this bit transitions from 0 to 1. Register bit PORT.CR1.BENA must be set and the receive clock running in order for the pattern load to take affect.

Bit 0: Transmit Pattern Inversion Control (TPIC) – When 0, the transmit outgoing data stream is not altered. When 1, the transmit outgoing data stream is inverted.

Register Name: **BERT.PCR**
 Register Description: **BERT Pattern Configuration Register**
 Register Address: **(0,2,4,6)62h**

Bit #	15	14	13	12	11	10	9	8
Name	--	--	--	PTF4	PTF3	PTF2	PTF1	PTF0
Default	0	0	0	0	0	0	0	0

Bit #	7	6	5	4	3	2	1	0
Name	--	QRSS	PTS	PLF4	PLF3	PLF2	PLF1	PLF0
Default	0	0	0	0	0	0	0	0

Bits 12 to 8: Pattern Tap Feedback (PTF[4:0]) – These five bits control the PRBS “tap” feedback of the pattern generator. The “tap” feedback will be from bit y of the pattern generator ($y = \text{PTF}[4:0] + 1$). These bits are ignored when programmed for a repetitive pattern. For a PRBS signal, the feedback is an XOR of bit n and bit y .

Bit 6: QRSS Enable (QRSS) – When 0, the pattern generator configuration is controlled by PTS, PLF[4:0], and BSP[31:0]. When 1, the pattern generator configuration is forced to a PRBS pattern with a generating polynomial of $x^{20} + x^{17} + 1$. The output of the pattern generator will be forced to one if the next fourteen output bits are all zero.

Bit 5: Pattern Type Select (PTS) – When 0, the pattern is a PRBS pattern. When 1, the pattern is a repetitive pattern.

Bits 4 to 0: Pattern Length Feedback (PLF[4:0]) – These five bits control the “length” feedback of the pattern generator. The “length” feedback will be from bit n of the pattern generator ($n = \text{PLF}[4:0] + 1$). For a PRBS signal, the feedback is an XOR of bit n and bit y . For a repetitive pattern the feedback is bit n .

Register Name: **BERT.SPR1**
 Register Description: **BERT Seed/Pattern Register #1**
 Register Address: **(0,2,4,6)64h**

Bit #	15	14	13	12	11	10	9	8
Name	BSP15	BSP14	BSP13	BSP12	BSP11	BSP10	BSP9	BSP8
Default	0	0	0	0	0	0	0	0

Bit #	7	6	5	4	3	2	1	0
Name	BSP7	BSP6	BSP5	BSP4	BSP3	BSP2	BSP1	BSP0
Default	0	0	0	0	0	0	0	0

Bits 15 to 0: BERT Seed/Pattern (BSP[15:0]) – Lower sixteen bits of 32 bits. Register description follows next register.

Register Name: **BERT.SPR2**
 Register Description: **BERT Seed/Pattern Register #2**
 Register Address: **(0,2,4,6)66h**

Bit #	15	14	13	12	11	10	9	8
Name	BSP31	BSP30	BSP29	BSP28	BSP27	BSP26	BSP25	BSP24
Default	0	0	0	0	0	0	0	0

Bit #	7	6	5	4	3	2	1	0
Name	BSP23	BSP22	BSP21	BSP20	BSP19	BSP18	BSP17	BSP16
Default	0	0	0	0	0	0	0	0

Bits 15 to 0: BERT Seed/Pattern (BSP[31:16]) - Upper 16 bits of 32 bits.

BERT Seed/Pattern (BSP[31:0]) – These 32 bits are the programmable seed for a transmit PRBS pattern, or the programmable pattern for a transmit or receive repetitive pattern. BSP(31) will be the first bit output on the transmit side for a 32-bit repetitive pattern or 32-bit length PRBS. BSP(31) will be the first bit input on the receive side for a 32-bit repetitive pattern.

Register Name: **BERT.TEICR**
 Register Description: **BERT Transmit Error Insertion Control Register**
 Register Address: **(0,2,4,6)68h**

Bit #	15	14	13	12	11	10	9	8
Name	--	--	--	--	--	--	--	--
Default	0	0	0	0	0	0	0	0

Bit #	7	6	5	4	3	2	1	0
Name	--	--	TEIR2	TEIR1	TEIR0	BEI	TSEI	MEIMS
Default	0	0	0	0	0	0	0	0

Bits 5 to 3: Transmit Error Insertion Rate (TEIR[2:0]) – These three bits indicate the rate at which errors are inserted in the output data stream. One out of every 10^n bits is inverted. TEIR[2:0] is the value n. A TEIR[2:0] value of 0 disables error insertion at a specific rate. A TEIR[2:0] value of 1 result in every 10^{th} bit being inverted. A TEIR[2:0] value of 2 result in every 100^{th} bit being inverted. Error insertion starts when this register is written to with a TEIR[2:0] value that is non-zero. If this register is written to during the middle of an error insertion process, the new error rate will be started after the next error is inserted.

TEIR[2:0]	Error Rate
000	Disabled
001	1×10^{-1}
010	1×10^{-2}
011	1×10^{-3}
100	1×10^{-4}
101	1×10^{-5}
110	1×10^{-6}
111	1×10^{-7}

Bit 2: Bit Error Insertion Enable (BEI) – When 0, single bit error insertion is disabled. When 1, single bit error insertion is enabled.

Bit 1: Transmit Single Error Insert (TSEI) – This bit causes a bit error to be inserted in the transmit data stream if manual error insertion is disabled (MEIMS = 0) and single bit error insertion is enabled. A 0 to 1 transition causes a single bit error to be inserted. For a second bit error to be inserted, this bit must be set to 0, and back to 1. Note: If MEIMS is low, and this bit transitions more than once between error insertion opportunities, only one error will be inserted.

Bit 0: Manual Error Insert Mode Select (MEIMS) – When 0, error insertion is initiated by the TSEI register bit. When 1, error insertion is initiated by the transmit manual error insertion signal (TMEI). Note: If TMEI or TSEI is one, changing the state of this bit may cause a bit error to be inserted.

Register Name: **BERT.SR**
 Register Description: **BERT Status Register**
 Register Address: **(0,2,4,6)6Ch**

Bit #	15	14	13	12	11	10	9	8
Name	--	--	--	--	--	--	--	--
Bit #	7	6	5	4	3	2	1	0
Name	--	--	--	--	<u>PMS</u>	--	<u>BEC</u>	<u>OOS</u>

Bit 3: Performance Monitoring Update Status (PMS) – This bit indicates the status of the receive performance monitoring register (counters) update. This bit will transition from low to high when the update is completed. PMS will be forced low when the LPMU bit (PMUM = 0) or the global or port PMU bit (PMUM=1) goes low.

Bit 1: Bit Error Count (BEC) – When 0, the bit error count is zero. When 1, the bit error count is one or more. This bit is cleared when the user updates the BERT counters via the PMU bit (BERT.CR).

Bit 0: Out Of Synchronization (OOS) – When 0, the receive pattern generator is synchronized to the incoming pattern. When 1, the receive pattern generator is not synchronized to the incoming pattern.

Register Name: **BERT.SRL**
 Register Description: **BERT Status Register Latched**
 Register Address: **(0,2,4,6)6Eh**

Bit #	15	14	13	12	11	10	9	8
Name	--	--	--	--	--	--	--	--
Bit #	7	6	5	4	3	2	1	0
Name	--	--	--	--	<u>PMSL</u>	<u>BEL</u>	<u>BECL</u>	<u>OOSL</u>

Bit 3: Performance Monitoring Update Status Latched (PMSL) – This bit is set when the PMS bit transitions from 0 to 1.

Bit 2: Bit Error Latched (BEL) – This bit is set when a bit error is detected.

Bit 1: Bit Error Count Latched (BECL) – This bit is set when the BEC bit transitions from 0 to 1.

Bit 0: Out Of Synchronization Latched (OOSL) – This bit is set when the OOS bit changes state.

Register Name: **BERT.SRIE**
 Register Description: **BERT Status Register Interrupt Enable**
 Register Address: **(0,2,4,6)70h**

Bit #	15	14	13	12	11	10	9	8
Name	--	--	--	--	--	--	--	--
Default	0	0	0	0	0	0	0	0

Bit #	7	6	5	4	3	2	1	0
Name	--	--	--	--	PMSIE	BEIE	BECIE	OOSIE
Default	0	0	0	0	0	0	0	0

Bit 3: Performance Monitoring Update Status Interrupt Enable (PMSIE) – This bit enables an interrupt if the PMSL bit is set.

0 = interrupt disabled
 1 = interrupt enabled

Bit 2: Bit Error Interrupt Enable (BEIE) – This bit enables an interrupt if the BEL bit is set and the bit in [GL.ISRIE](#).PSRIE[4:1] that corresponds to this port is set.

0 = interrupt disabled
 1 = interrupt enabled

Bit 1: Bit Error Count Interrupt Enable (BECIE) – This bit enables an interrupt if the BECL bit is set and the bit in [GL.ISRIE](#).PSRIE[4:1] that corresponds to this port is set.

0 = interrupt disabled
 1 = interrupt enabled

Bit 0: Out Of Synchronization Interrupt Enable (OOSIE) – This bit enables an interrupt if the OOSL bit is set and the bit in [GL.ISRIE](#).PSRIE[4:1] that corresponds to this port is set.

0 = interrupt disabled
 1 = interrupt enabled

Register Name: **BERT.RBECR1**
 Register Description: **BERT Receive Bit Error Count Register #1**
 Register Address: **(0,2,4,6)74h**

Bit #	15	14	13	12	11	10	9	8
Name	<u>BEC15</u>	<u>BEC14</u>	<u>BEC13</u>	<u>BEC12</u>	<u>BEC11</u>	<u>BEC10</u>	<u>BEC9</u>	<u>BEC8</u>
Default	0	0	0	0	0	0	0	0

Bit #	7	6	5	4	3	2	1	0
Name	<u>BEC7</u>	<u>BEC6</u>	<u>BEC5</u>	<u>BEC4</u>	<u>BEC3</u>	<u>BEC2</u>	<u>BEC1</u>	<u>BEC0</u>
Default	0	0	0	0	0	0	0	0

Bits 15 to 0: Bit Error Count (BEC[15:0]) – Lower sixteen bits of 24 bits. Register description follows next register.

Register Name: **BERT.RBECR2**
 Register Description: **BERT Receive Bit Error Count Register #2**
 Register Address: **(0,2,4,6)76h**

Bit #	15	14	13	12	11	10	9	8
Name	--	--	--	--	--	--	--	--
Default	0	0	0	0	0	0	0	0

Bit #	7	6	5	4	3	2	1	0
Name	<u>BEC23</u>	<u>BEC22</u>	<u>BEC21</u>	<u>BEC20</u>	<u>BEC19</u>	<u>BEC18</u>	<u>BEC17</u>	<u>BEC16</u>
Default	0	0	0	0	0	0	0	0

Bits 7 to 0: Bit Error Count (BEC[23:16]) - Upper 8-bits of Register.

Bit Error Count (BEC[23:0]) – These twenty-four bits indicate the number of bit errors detected in the incoming data stream. This count stops incrementing when it reaches a count of FF FFFFh. This bit error counter will not increment when an OOS condition exists. This register is updated via the PMU signal (see Section [10.4.5](#)).

Register Name: **BERT.RBCR1**
 Register Description: **Receive Bit Count Register #1**
 Register Address: **(0,2,4,6)78h**

Bit #	15	14	13	12	11	10	9	8
Name	<u>BC15</u>	<u>BC14</u>	<u>BC13</u>	<u>BC12</u>	<u>BC11</u>	<u>BC10</u>	<u>BC9</u>	<u>BC8</u>
Default	0	0	0	0	0	0	0	0

Bit #	7	6	5	4	3	2	1	0
Name	<u>BC7</u>	<u>BC6</u>	<u>BC5</u>	<u>BC4</u>	<u>BC3</u>	<u>BC2</u>	<u>BC1</u>	<u>BC0</u>
Default	0	0	0	0	0	0	0	0

Bits 15 to 0: Bit Count (BC[15:0]) – Lower sixteen bits of 32 bits. Register description follows next register.

Register Name: **BERT.RBCR2**
 Register Description: **Receive Bit Count Register #2**
 Register Address: **(0,2,4,6)7Ah**

Bit #	15	14	13	12	11	10	9	8
Name	<u>BC31</u>	<u>BC30</u>	<u>BC29</u>	<u>BC28</u>	<u>BC27</u>	<u>BC26</u>	<u>BC25</u>	<u>BC24</u>
Default	0	0	0	0	0	0	0	0

Bit #	7	6	5	4	3	2	1	0
Name	<u>BC23</u>	<u>BC22</u>	<u>BC21</u>	<u>BC20</u>	<u>BC19</u>	<u>BC18</u>	<u>BC17</u>	<u>BC16</u>
Default	0	0	0	0	0	0	0	0

Bits 15 to 0: Bit Count (BC[31:16]) - Upper 16 bits of 32 bits.

Bit Count (BC[31:0]) – These thirty-two bits indicate the number of bits in the incoming data stream. This count stops incrementing when it reaches a count of FFFF FFFFh. This bit counter will not increment when an OOS condition exists. This register is updated via the PMU signal (see Section [10.4.5](#)).

12.5 B3ZS/HDB3 Line Encoder/Decoder

12.5.1 Transmit Side Line Encoder/Decoder Register Map

The transmit side utilizes one register.

Table 12-15. Transmit Side B3ZS/HDB3 Line Encoder/Decoder Register Map

Address	Register	Register Description
(0,2,4,6)8Ch	LINE.TCR	Line Transmit Control Register
(0,2,4,6)8Eh	--	Unused

12.5.1.1 Register Bit Descriptions

Register Name: **LINE.TCR**
 Register Description: **Line Transmit Control Register**
 Register Address: **(0,2,4,6)8Ch**

Bit #	15	14	13	12	11	10	9	8
Name	--	--	--	--	--	--	--	--
Default	0	0	0	0	0	0	0	0

Bit #	7	6	5	4	3	2	1	0
Name	--	--	--	TZSD	EXZI	BPVI	TSEI	MEIMS
Default	0	0	0	0	0	0	0	0

Bit 4: Transmit Zero Suppression Encoding Disable (TZSD) – When 0, the B3ZS/HDB3 Encoder performs zero suppression (B3ZS or HDB3) and AMI encoding. When 1, zero suppression (B3ZS or HDB3) encoding is disabled, and only AMI encoding is performed.

Bit 3: Excessive Zero Insert Enable (EXZI) – When 0, excessive zero (EXZ) event insertion is disabled. When 1, EXZ event insertion is enabled.

Bit 2: Bipolar Violation Insert Enable (BPVI) – When 0, bipolar violation (BPV) insertion is disabled. When 1, BPV insertion is enabled.

Bit 1: Transmit Single Error Insert (TSEI) – This bit causes an error of the enabled type(s) to be inserted in the transmit data stream if manual error insertion is disabled (MEIMS = 0). A 0 to 1 transition causes a single error to be inserted. For a second error to be inserted, this bit must be set to 0, and back to 1. Note: If MEIMS is low, and this bit transitions more than once between error insertion opportunities, only one error will be inserted.

Bit 0: Manual Error Insert Mode Select (MEIMS) – When 0, error insertion is initiated by the TSEI register bit. When 1, error insertion is initiated by the transmit manual error insertion signal (TMEI). Note: If TMEI or TSEI is one, changing the state of this bit may cause an error to be inserted.

12.5.2 Receive Side Line Encoder/Decoder Register Map

The receive side utilizes six registers.

Table 12-16. Receive Side B3ZS/HDB3 Line Encoder/Decoder Register Map

Address	Register	Register Description
(0,2,4,6)90h	LINE.RCR	Line Receive Control Register
(0,2,4,6)92h	--	Unused
(0,2,4,6)94h	LINE.RSR	Line Receive Status Register
(0,2,4,6)96h	LINE.RSRL	Line Receive Status Register Latched
(0,2,4,6)98h	LINE.RSRIE	Line Receive Status Register Interrupt Enable
(0,2,4,6)9Ah	--	Unused
(0,2,4,6)9Ch	LINE.RBPVCR	Line Receive Bipolar Violation Count Register
(0,2,4,6)9Eh	LINE.REXZCR	Line Receive Excessive Zero Count Register

12.5.2.1 Register Bit Descriptions

Register Name: **LINE.RCR**
 Register Description: **Line Receive Control Register**
 Register Address: **(0.2.4.6)90h**

Bit #	15	14	13	12	11	10	9	8
Name	--	--	--	--	--	--	--	--
Default	0	0	0	0	0	0	0	0

Bit #	7	6	5	4	3	2	1	0
Name	--	--	--	--	E3CVE	REZSF	RDZSF	RZSD
Default	0	0	0	0	0	0	0	0

Bit 2: E3 Code Violation Enable (E3CVE) – When 0, the bipolar violation count will be a count of bipolar violations. When 1, the bipolar violation count will be a count of E3 line coding violations. Note: E3 line coding violations are defined as consecutive bipolar violations of the same polarity in ITU O.161. This bit is ignored in B3ZS mode.

Bit 2: Receive BPV Error Detection Zero Suppression Code Format (REZSF) – When 0, BPV error detection detects a B3ZS signature if a zero is followed by a bipolar violation (BPV), and an HDB3 signature if two zeros are followed by a BPV. When 1, BPV error detection detects a B3ZS signature if a zero is followed by a BPV that has the opposite polarity of the BPV in the previous B3ZS signature, and an HDB3 signature if two zeros are followed by a BPV that has the opposite polarity of the BPV in the previous HDB3 signature. Note: Immediately after a reset, this bit is ignored. The first B3ZS signature is defined as a zero followed by a BPV, and the first HDB3 signature is defined as two zeros followed by a BPV. All subsequent B3ZS/HDB3 signatures will be determined by the setting of this bit.

Note: The default setting (REZSF = 0) conforms to ITU O.162. The default setting may falsely decode actual BPVs that are not codewords. It is recommended that REZSF be set to one for most applications. This setting is more robust to accurately detect codewords.

Bit 1: Receive Zero Suppression Decoding Zero Suppression Code Format (RDZSF) – When 0, zero suppression decoding detects a B3ZS signature if a zero is followed by a bipolar violation (BPV), and an HDB3 signature if two zeros are followed by a BPV. When 1, zero suppression decoding detects a B3ZS signature if a zero is followed by a BPV that has the opposite polarity of the BPV in the previous B3ZS signature, and an HDB3 signature if two zeros are followed by a BPV that has the opposite polarity of the BPV in the previous HDB3 signature. Note: Immediately after a reset (DRST or RST low), this bit is ignored. The first B3ZS signature is defined

as a zero followed by a BPV, and the first HDB3 signature is defined as two zeros followed by a BPV. All subsequent B3ZS/HDB3 signatures will be determined by the setting of this bit.

Bit 0: Receive Zero Suppression Decoding Disable (RZSD) – When 0, the B3ZS/HDB3 Decoder performs zero suppression (B3ZS or HDB3) and AMI decoding. When 1, zero suppression (B3ZS or HDB3) decoding is disabled, and only AMI decoding is performed.

Register Name: **LINE.RSR**
 Register Description: **Line Receive Status Register**
 Register Address: **(0.2.4.6)94h**

Bit #	15	14	13	12	11	10	9	8
Name	--	--	--	--	--	--	--	--
Bit #	7	6	5	4	3	2	1	0
Name	--	--	--	--	<u>EXZC</u>	--	<u>BPVC</u>	<u>LOS</u>

Bit 3: Excessive Zero Count (EXZC) – When 0, the excessive zero count is zero. When 1, the excessive zero count is one or more.

Bit 1: Bipolar Violation Count (BPVC) – When 0, the bipolar violation count is zero. When 1, the bipolar violation count is one or more.

Bit 0: Loss Of Signal (LOS) – When 0, the receive line is not in a loss of signal (LOS) condition. When 1, the receive line is in an LOS condition. See Section [10.10.6](#).

Note: When zero suppression (B3ZS or HDB3) decoding is disabled, the LOS condition is cleared, and cannot be detected

Register Name: **LINE.RSRL**
 Register Description: **Line Receive Status Register Latched**
 Register Address: **(0.2.4.6)96h**

Bit #	15	14	13	12	11	10	9	8
Name	--	--	--	--	--	--	--	--
Bit #	7	6	5	4	3	2	1	0
Name	--	--	<u>ZSCDL</u>	<u>EXZL</u>	<u>EXZCL</u>	<u>BPVL</u>	<u>BPVCL</u>	<u>LOSL</u>

Bit 5: Zero Suppression Code Detect Latched (ZSCDL) – This bit is set when a B3ZS or HDB3 signature is detected.

Bit 4: Excessive Zero Latched (EXZL) – This bit is set when an excessive zero event is detected on the incoming bipolar data stream.

Bit 3: Excessive Zero Count Latched (EXZCL) – This bit is set when the LINE.RSR.EXZC bit transitions from zero to one.

Bit 2: Bipolar Violation Latched (BPVL) – This bit is set when a bipolar violation (or E3 LCV if enabled) is detected on the incoming bipolar data stream.

Bit 1: Bipolar Violation Count Latched (BPVCL) – This bit is set when the LINE.RSR.BPVC bit transitions from zero to one.

Bit 0: Loss of Signal Change Latched (LOSL) – This bit is set when the LINE.RSR.LOS bit changes state.

Register Name: **LINE.RSRIE**
 Register Description: **Line Receive Status Register Interrupt Enable**
 Register Address: **(0.2.4.6)98h**

Bit #	15	14	13	12	11	10	9	8
Name	--	--	--	--	--	--	--	--
Default	0	0	0	0	0	0	0	0

Bit #	7	6	5	4	3	2	1	0
Name	--	--	ZSCDIE	EXZIE	EXZCIE	BPVIE	BPVCIE	LOSIE
Default	0	0	0	0	0	0	0	0

Bit 5: Zero Suppression Code Detect Interrupt Enable (ZSCDIE) – This bit enables an interrupt if the *LINE.RSRL.ZSCDL* bit is set and the bit in [GL.ISRIE.PSRIE\[4:1\]](#) that corresponds to this port is set.

0 = interrupt disabled

1 = interrupt enabled

Bit 4: Excessive Zero Interrupt Enable (EXZIE) – This bit enables an interrupt if the *LINE.RSRL.EXZL* bit is set and the bit in [GL.ISRIE.PSRIE\[4:1\]](#) that corresponds to this port is set.

0 = interrupt disabled

1 = interrupt enabled

Bit 3: Excessive Zero Count Interrupt Enable (EXZCIE) – This bit enables an interrupt if the *LINE.RSRL.EXZCL* bit is set and the bit in [GL.ISRIE.PSRIE\[4:1\]](#) that corresponds to this port is set.

0 = interrupt disabled

1 = interrupt enabled

Bit 2: Bipolar Violation Interrupt Enable (BPVIE) – This bit enables an interrupt if the *LINE.RSRL.BPVL* bit is set and the bit in [GL.ISRIE.PSRIE\[4:1\]](#) that corresponds to this port is set.

0 = interrupt disabled

1 = interrupt enabled

Bit 1: Bipolar Violation Count Interrupt Enable (BPVCIE) – This bit enables an interrupt if the *LINE.RSRL.BPVCL* bit and the bit in [GL.ISRIE.PSRIE\[4:1\]](#) that corresponds to this port is set. is set.

0 = interrupt disabled

1 = interrupt enabled

Bit 0: Loss Of Signal Interrupt Enable (LOSIE) – This bit enables an interrupt if the *LINE.RSRL.LOSL* bit is set and the bit in [GL.ISRIE.PSRIE\[4:1\]](#) that corresponds to this port is set.

0 = interrupt disabled

1 = interrupt enabled

Register Name: **LINE.RBPVCR**
 Register Description: **Line Receive Bipolar Violation Count Register**
 Register Address: **(0.2.4.6)9Ch**

Bit #	15	14	13	12	11	10	9	8
Name	<u>BPV15</u>	<u>BPV14</u>	<u>BPV13</u>	<u>BPV12</u>	<u>BPV11</u>	<u>BPV10</u>	<u>BPV9</u>	<u>BPV8</u>
Default	0	0	0	0	0	0	0	0

Bit #	7	6	5	4	3	2	1	0
Name	<u>BPV7</u>	<u>BPV6</u>	<u>BPV5</u>	<u>BPV4</u>	<u>BPV3</u>	<u>BPV2</u>	<u>BPV1</u>	<u>BPV0</u>
Default	0	0	0	0	0	0	0	0

Bits 15 to 0: Bipolar Violation Count (BPV[15:0]) – These sixteen bits indicate the number of bipolar violations detected on the incoming bipolar data stream. This register is updated via the PMU signal (see Section [10.4.5](#)).

Register Name: **LINE.REXZCR**
 Register Description: **Line Receive Excessive Zero Count Register**
 Register Address: **(0.2.4.6)9Eh**

Bit #	15	14	13	12	11	10	9	8
Name	<u>EXZ15</u>	<u>EXZ14</u>	<u>EXZ13</u>	<u>EXZ12</u>	<u>EXZ11</u>	<u>EXZ10</u>	<u>EXZ9</u>	<u>EXZ8</u>
Default	0	0	0	0	0	0	0	0

Bit #	7	6	5	4	3	2	1	0
Name	<u>EXZ7</u>	<u>EXZ6</u>	<u>EXZ5</u>	<u>EXZ4</u>	<u>EXZ3</u>	<u>EXZ2</u>	<u>EXZ1</u>	<u>EXZ0</u>
Default	0	0	0	0	0	0	0	0

Bits 15 to 0: Excessive Zero Count (EXZ[15:0]) – These sixteen bits indicate the number of excessive zero conditions detected on the incoming bipolar data stream. This register is updated via the PMU signal (see Section [10.4.5](#)).

12.6 HDLC

12.6.1 HDLC Transmit Side Register Map

The transmit side utilizes five registers.

Table 12-17. Transmit Side HDLC Register Map

Address	Register	Register Description
(0,2,4,6)A0h	HDLC.TCR	HDLC Transmit Control Register
(0,2,4,6)A2h	HDLC.TFDR	HDLC Transmit FIFO Data Register
(0,2,4,6)A4h	HDLC.TSR	HDLC Transmit Status Register
(0,2,4,6)A6h	HDLC.TSRL	HDLC Transmit Status Register Latched
(0,2,4,6)A8h	HDLC.TSRIE	HDLC Transmit Status Register Interrupt Enable
(0,2,4,6)AAh	--	Unused
(0,2,4,6)ACh	--	Unused
(0,2,4,6)AEh	--	Unused

12.6.1.1 Register Bit Descriptions

Register Name: **HDLC.TCR**
 Register Description: **HDLC Transmit Control Register**
 Register Address: **(0,2,4,6)A0h**

Bit #	15	14	13	12	11	10	9	8
Name	--	--	--	TDAL4	TDAL3	TDAL2	TDAL1	TDAL0
Default	0	0	0	0	1	0	0	0

Bit #	7	6	5	4	3	2	1	0
Name	--	TPSD	TFEI	TIFV	TBRE	TDIE	TFPD	TFRST
Default	0	0	0	0	0	0	0	0

Bits 12 to 8: Transmit HDLC Data Storage Available Level (TDAL[4:0]) – These five bits indicate the minimum number of bytes ($(TDAL \times 8) + 1$) that must be available for storage (do not contain data) in the Transmit FIFO for HDLC data storage to be available. For example, a value of 21 (15h) results in HDLC data storage being available (THDA=1) when the Transmit FIFO has 169 (A9h) bytes or more available for storage, and HDLC data storage not being available (THDA=0) when the Transmit FIFO has 168 (A8h) bytes or less available for storage.

Default value (after reset) is 128 bytes minimum available.

Bit 6: Transmit Packet Start Disable (TPSD) – When 0, the Transmit Packet Processor will continue sending packets after the current packet end. When 1, the Transmit Packet Processor will stop sending packets after the current packet end.

Bit 5: Transmit FCS Error Insertion (TFEI) – When 0, the calculated FCS (inverted CRC-16) is appended to the packet. When 1, the inverse of the calculated FCS (non-inverted CRC-16) is appended to the packet causing an FCS error. This bit is ignored if transmit FCS processing is disabled (TFPD = 1).

Bit 4: Transmit Inter-frame Fill Value (TIFV) – When 0, inter-frame fill is done with the flag sequence (7Eh). When 1, inter-frame fill is done with all '1's.

Bit 3: Transmit Bit Reordering Enable (TBRE) – When 0, bit reordering is disabled (The first bit transmitted is the LSB of the Transmit FIFO Data byte TFD[0]). When 1, bit reordering is enabled (The first bit transmitted is the MSB of the Transmit FIFO Data byte TFD[7]).

Bit 2: Transmit Data Inversion Enable (TDIE) – When 0, the outgoing data is directly output from packet processing. When 1, the outgoing data is inverted before being output from packet processing.

Bit 1: Transmit FCS Processing Disable (TFPD) – This bit controls whether or not an FCS is calculated and appended to the end of each packet. When 0, the calculated FCS bytes are appended to the end of the packet. When 1, the packet is transmitted without an FCS.

Bit 0: Transmit FIFO Reset (TFRST) – When 0, the Transmit FIFO will resume normal operations, however, data is discarded until a start of packet is received after RAM power-up is completed. When 1, the Transmit FIFO is emptied, any transfer in progress is halted, the FIFO RAM is powered down, and all incoming data is discarded (all TFDR register writes are ignored).

Register Name: **HDLC.TFDR**
 Register Description: **HDLC Transmit FIFO Data Register**
 Register Address: **(0,2,4,6)A2h**

Bit #	15	14	13	12	11	10	9	8
Name	TFD7	TFD6	TFD5	TFD4	TFD3	TFD2	TFD1	TFD0
Default	0	0	0	0	0	0	0	0

Bit #	7	6	5	4	3	2	1	0
Name	--	--	--	--	--	--	--	TDPE
Default	0	0	0	0	0	0	0	0

Note: The FIFO data and status are loaded into the Transmit FIFO when the Transmit FIFO Data (TFD[7:0]) is written (upper byte write). When read, the value of these bits is always zero.

Bits 15 to 8: Transmit FIFO Data (TFD[7:0]) – These eight bits are the packet data to be stored in the Transmit FIFO. TFD[7] is the MSB, and TFD[0] is the LSB. If bit reordering is disabled, TFD[0] is the first bit transmitted, and TFD[7] is the last bit transmitted. If bit reordering is enabled, TFD[7] is the first bit transmitted, and TFD[0] is the last bit transmitted.

Bit 0: Transmit FIFO Data Packet End (TDPE) – When 0, the Transmit FIFO data is not a packet end. When 1, the Transmit FIFO data is a packet end.

Register Name: **HDLC.TSR**
 Register Description: **HDLC Transmit Status Register**
 Register Address: **(0,2,4,6)A4h**

Bit #	15	14	13	12	11	10	9	8
Name	--	--	<u>TFFL5</u>	<u>TFFL4</u>	<u>TFFL3</u>	<u>TFFL2</u>	<u>TFFL1</u>	<u>TFFL0</u>
Bit #	7	6	5	4	3	2	1	0
Name	--	--	--	--	--	<u>TFF</u>	<u>TFE</u>	<u>THDA</u>

Bits 13 to 8: Transmit FIFO Fill Level (TFFL[5:0]) – These six bits indicate the number of eight byte groups available for storage (do not contain data) in the Transmit FIFO. E.g., a value of 21 (15h) indicates the FIFO has 168 (A8h) to 175 (AFh) bytes are available for storage.

Bit 2: Transmit FIFO Full (TFF) – When 0, the Transmit FIFO contains 255 or less bytes of data. When 1, the Transmit FIFO is full.

Bit 1: Transmit FIFO Empty (TFE) – When 0, the Transmit FIFO contains at least one byte of data. When 1, the Transmit FIFO is empty.

Bit 0: Transmit HDLC Data Storage Available (THDA) – When 0, the Transmit FIFO has less storage space available in the Transmit FIFO than the Transmit HDLC data storage available level (TDAL[4:0]). When 1, the Transmit FIFO has the same or more storage space available than the Transmit FIFO HDLC data storage available level.

Register Name: **HDLC.TSRL**
 Register Description: **HDLC Transmit Status Register Latched**
 Register Address: **(0,2,4,6)A6h**

Bit #	15	14	13	12	11	10	9	8
Name	--	--	--	--	--	--	--	--
Bit #	7	6	5	4	3	2	1	0
Name	--	--	<u>TFOL</u>	<u>TFUL</u>	<u>TPEL</u>	--	<u>TFEL</u>	<u>THDAL</u>

Bit 5: Transmit FIFO Overflow Latched (TFOL) – This bit is set when a Transmit FIFO overflow condition occurs.

Bit 4: Transmit FIFO Underflow Latched (TFUL) – This bit is set when a Transmit FIFO underflow condition occurs. An underflow condition results in a loss of data.

Bit 3: Transmit Packet End Latched (TPEL) – This bit is set when an end of packet is read from the Transmit FIFO.

Bit 1: Transmit FIFO Empty Latched (TFEL) – This bit is set when the TFE bit transitions from 0 to 1.

Note: This bit is also set when HDLC.TCR.TFRST is deasserted.

Bit 0: Transmit HDLC Data Available Latched (THDAL) – This bit is set when the THDA bit transitions from 0 to 1.

Note: This bit is also set when HDLC.TCR.TFRST is deasserted.

Register Name: **HDLC.TSRIE**
 Register Description: **HDLC Transmit Status Register Interrupt Enable**
 Register Address: **(0,2,4,6)A8h**

Bit #	15	14	13	12	11	10	9	8
Name	--	--	--	--	--	--	--	--
Default	0	0	0	0	0	0	0	0

Bit #	7	6	5	4	3	2	1	0
Name	--	--	TFOIE	TFUIE	TPEIE	--	TFEIE	THDAIE
Default	0	0	0	0	0	0	0	0

Bit 5: Transmit FIFO Overflow Interrupt Enable (TFOIE) – This bit enables an interrupt if the TFOL bit is set and the bit in [GL.ISRIE.PSRIE\[4:1\]](#) that corresponds to this port is set.

0 = interrupt disabled
 1 = interrupt enabled

Bit 4: Transmit FIFO Underflow Interrupt Enable (TFUIE) – This bit enables an interrupt if the TFUL bit is set and the bit in [GL.ISRIE.PSRIE\[4:1\]](#) that corresponds to this port is set.

0 = interrupt disabled
 1 = interrupt enabled

Bit 3: Transmit Packet End Interrupt Enable (TPEIE) – This bit enables an interrupt if the TPEL bit is set and the bit in [GL.ISRIE.PSRIE\[4:1\]](#) that corresponds to this port is set.

0 = interrupt disabled
 1 = interrupt enabled

Bit 2: Transmit FIFO Full Interrupt Enable (TFFIE) – This bit enables an interrupt if the TFFL bit is set and the bit in [GL.ISRIE.PSRIE\[4:1\]](#) that corresponds to this port is set.

0 = interrupt disabled
 1 = interrupt enabled

Bit 1: Transmit FIFO Empty Interrupt Enable (TFEIE) – This bit enables an interrupt if the TFEL bit is set and the bit in [GL.ISRIE.PSRIE\[4:1\]](#) that corresponds to this port is set.

0 = interrupt disabled
 1 = interrupt enabled

Bit 0: Transmit HDLC Data Available Interrupt Enable (THDAIE) – This bit enables an interrupt if the THDAL bit is set and the bit in [GL.ISRIE.PSRIE\[4:1\]](#) that corresponds to this port is set.

0 = interrupt disabled
 1 = interrupt enabled

12.6.2 HDLC Receive Side Register Map

The receive side utilizes five registers.

Table 12-18. Receive Side HDLC Register Map

Address	Register	Register Description
(0,2,4,6)B0h	HDLC.RCR	HDLC Receive Control Register
(0,2,4,6)B2h	--	Unused
(0,2,4,6)B4h	HDLC.RSR	HDLC Receive Status Register
(0,2,4,6)B6h	HDLC.RSRL	HDLC Receive Status Register Latched
(0,2,4,6)B8h	HDLC.RSRIE	HDLC Receive Status Register Interrupt Enable
(0,2,4,6)BAh	--	Unused
(0,2,4,6)BCh	HDLC.RFDR	HDLC Receive FIFO Data Register
(0,2,4,6)BEh	--	Unused

12.6.2.1 Register Bit Descriptions

Register Name: **HDLC.RCR**
 Register Description: **HDLC Receive Control Register**
 Register Address: **(0,2,4,6)B0h**

Bit #	15	14	13	12	11	10	9	8
Name	--	--	--	RDAL4	RDAL3	RDAL2	RDAL1	RDAL0
Default	0	0	0	0	1	0	0	0

Bit #	7	6	5	4	3	2	1	0
Name	--	--	--	--	RBRE	RDIE	RFPD	RFRST
Default	0	0	0	0	0	0	0	0

Bits 13 to 8: Receive HDLC Data Available Level (RDAL[4:0]) – These five bits indicate the minimum number of eight byte groups that must be stored (contain data) in the Receive FIFO before HDLC data is considered to be available (RHDA=1). For example, a value of 21 (15h) results in HDLC data being available when the Receive FIFO contains 168 (A8h) bytes or more.

Bit 3: Receive Bit Reordering Enable (RBRE) – When 0, bit reordering is disabled (The first bit received is in the LSB of the Receive FIFO Data byte RFD[0]). When 1, bit reordering is enabled (The first bit received is in the MSB of the Receive FIFO Data byte RFD[7]).

Bit 2: Receive Data Inversion Enable (RDIE) – When 0, the incoming data is directly passed on for packet processing. When 1, the incoming data is inverted before being passed on for packet processing.

Bit 1: Receive FCS Processing Disable (RFPD) – When 0, FCS processing is performed (the packets have an FCS appended). When 1, FCS processing is disabled (the packets do not have an FCS appended).

Bit 0: Receive FIFO Reset (RFRST) – When 0, the Receive FIFO will resume normal operations, however, data is discarded until a start of packet is received after RAM power-up is completed. When 1, the Receive FIFO is emptied, any transfer in progress is halted, the FIFO RAM is powered down, the RHDA bit is forced low, and all incoming data is discarded.

Register Name: **HDLC.RSR**
 Register Description: **HDLC Receive Status Register**
 Register Address: **(0,2,4,6)B4h**

Bit #	15	14	13	12	11	10	9	8
Name	--	--	--	--	--	--	--	--
Bit #	7	6	5	4	3	2	1	0
Name	--	--	--	--	--	<u>RFF</u>	<u>RFE</u>	<u>RHDA</u>

Bit 2: Receive FIFO Full (RFF) – When 0, the Receive FIFO contains 255 or less bytes of data. When 1, the Receive FIFO is full.

Bit 1: Receive FIFO Empty (RFE) – When 0, the Receive FIFO contains at least one byte of data. When 1, the Receive FIFO is empty.

Bit 0: Receive HDLC Data Available (RHDA) – When 0, the Receive FIFO contains less data than the Receive HDLC data available level (RDAL[4:0]). When 1, the Receive FIFO contains the same or more data than the Receive HDLC data available level.

Register Name: **HDLC.RSRL**
 Register Description: **HDLC Receive Status Register Latched**
 Register Address: **(0,2,4,6)B6h**

Bit #	15	14	13	12	11	10	9	8
Name	--	--	--	--	--	--	--	--
Bit #	7	6	5	4	3	2	1	0
Name	<u>RFOL</u>	--	--	<u>RPEL</u>	<u>RPSL</u>	<u>RFFL</u>	--	<u>RHDAL</u>

Bit 7: Receive FIFO Overflow Latched (RFOL) – This bit is set when a Receive FIFO overflow condition occurs. An overflow condition results in a loss of data.

Bit 4: Receive Packet End Latched (RPEL) – This bit is set when an end of packet is stored in the Receive FIFO.

Bit 3: Receive Packet Start Latched (RPSL) – This bit is set when a start of packet is stored in the Receive FIFO.

Bit 2: Receive FIFO Full Latched (RFFL) – This bit is set when the RFF bit transitions from 0 to 1.

Bit 0: Receive HDLC Data Available Latched (RHDAL) – This bit is set when the RHDA bit transitions from 0 to 1.

Register Name: **HDLC.RSRIE**
 Register Description: **HDLC Receive Status Register Interrupt Enable**
 Register Address: **(0,2,4,6)B8h**

Bit #	15	14	13	12	11	10	9	8
Name	--	--	--	--	--	--	--	--
Default	0	0	0	0	0	0	0	0

Bit #	7	6	5	4	3	2	1	0
Name	RFOIE	--	--	RPEIE	RPSIE	RFFIE	--	RHDAIE
Default	0	0	0	0	0	0	0	0

Bit 7: Receive FIFO Overflow Interrupt Enable (RFOIE) – This bit enables an interrupt if the RFOL bit is set and the bit in [GL.ISRIE.PSRIE\[4:1\]](#) that corresponds to this port is set.

0 = interrupt disabled

1 = interrupt enabled

Bit 4: Receive Packet End Interrupt Enable (RPEIE) – This bit enables an interrupt if the RPEL bit is set and the bit in [GL.ISRIE.PSRIE\[4:1\]](#) that corresponds to this port is set.

0 = interrupt disabled

1 = interrupt enabled

Bit 3: Receive Packet Start Interrupt Enable (RPSIE) – This bit enables an interrupt if the RPSL bit is set and the bit in [GL.ISRIE.PSRIE\[4:1\]](#) that corresponds to this port is set.

0 = interrupt disabled

1 = interrupt enabled

Bit 2: Receive FIFO Full Interrupt Enable (RFFIE) – This bit enables an interrupt if the RFFL bit is set and the bit in [GL.ISRIE.PSRIE\[4:1\]](#) that corresponds to this port is set.

0 = interrupt disabled

1 = interrupt enabled

Bit 0: Receive HDLC Data Available Interrupt Enable (RHDAIE) – This bit enables an interrupt if the RHDAL bit is set and the bit in [GL.ISRIE.PSRIE\[4:1\]](#) that corresponds to this port is set.

0 = interrupt disabled

1 = interrupt enabled

Register Name: **HDLC.RFDR**
 Register Description: **HDLC Receive FIFO Data Register**
 Register Address: **(0,2,4,6)BCh**

Bit #	15	14	13	12	11	10	9	8
Name	<u>RFD7</u>	<u>RFD6</u>	<u>RFD5</u>	<u>RFD4</u>	<u>RFD3</u>	<u>RFD2</u>	<u>RFD1</u>	<u>RFD0</u>
Default	X	X	X	X	X	X	X	X

Bit #	7	6	5	4	3	2	1	0
Name	--	--	--	--	<u>RPS2</u>	<u>RPS1</u>	<u>RPS0</u>	<u>RFDV</u>
Default	0	0	0	0	X	X	X	0

Note: The FIFO data and status are updated when the Receive FIFO Data (RFD[7:0]) is read (upper byte read). When this register is read eight bits at a time, a read of the lower byte will reflect the status of the next read of the upper byte, and reading the upper byte when RFDV=0 may result in a loss of data.

Bits 15 to 8: Receive FIFO Data (RFD[7:0]) – These eight bits are the packet data stored in the Receive FIFO. RFD[7] is the MSB, and RFD[0] is the LSB. If bit reordering is disabled, RFD[0] is the first bit received, and RFD[7] is the last bit received. If bit reordering is enabled, RFD[7] is the first bit received, and RFD[0] is the last bit received.

Bits 3 to 1: Receive Packet Status (RPS[2:0]) – These three bits indicate the status of the received packet and packet data.

000 = packet middle

001 = packet start.

010 = reserved

011 = reserved

100 = packet end: good packet

101 = packet end: FCS errored packet.

110 = packet end: invalid packet (a non-integer number of bytes).

111 = packet end: aborted packet.

Bit 0: Receive FIFO Data Valid (RFDV) – When 0, the Receive FIFO data (RFD[7:0]) is invalid (the Receive FIFO is empty). When 1, the Receive FIFO data (RFD[7:0]) is valid.

12.7 FEAC Controller

12.7.1 FEAC Transmit Side Register Map

The transmit side utilizes five registers.

Table 12-19. FEAC Transmit Side Register Map

Address	Register	Register Description
(0,2,4,6)C0h	FEAC.TCR	FEAC Transmit Control Register
(0,2,4,6)C2h	FEAC.TFDR	FEAC Transmit Data Register
(0,2,4,6)C4h	FEAC.TSR	FEAC Transmit Status Register
(0,2,4,6)C6h	FEAC.TSRL	FEAC Transmit Status Register Latched
(0,2,4,6)C8h	FEAC.TSRIE	FEAC Transmit Status Register Interrupt Enable
(0,2,4,6)CAh	--	Unused
(0,2,4,6)CCh	--	Unused
(0,2,4,6)CEh	--	Unused

12.7.1.1 Register Bit Descriptions

Register Name: **FEAC.TCR**
 Register Description: **FEAC Transmit Control Register**
 Register Address: **(0,2,4,6)C0h**

Bit #	15	14	13	12	11	10	9	8
Name	--	--	--	--	--	--	--	--
Default	0	0	0	0	1	0	0	0
Bit #	7	6	5	4	3	2	1	0
Name	--	--	--	--	--	TFCL	TFS1	TFS0
Default	0	0	0	0	0	0	0	0

Bit 2: Transmit FEAC Codeword Load (TFCL) – A 0 to 1 transition on this bit loads the transmit FEAC processor mode select bits (TFS[1:0]), and transmit FEAC codes (TFCA[5:0] and TFCB[5:0]). Note: Whenever a FEAC codeword is loaded, any current FEAC codeword transmission in progress will be immediately halted, and the new FEAC codeword transmission will be started based on the new values for TFS[1:0], TFCA[5:0], and TFCB[5:0].

Bits 1 to 0: Transmit FEAC Codeword Select (TFS[1:0]) – These two bits control the transmit FEAC processor mode. The TFCL bit loads the mode set by this bit.

00 = Idle (all ones)

01 = single code (send code TFCA ten times and send all ones)

10 = dual code (send code TFCA ten times, send code TFCB ten times, and send all ones)

11 = continuous code (send code TFCA continuously)

Register Name: **FEAC.TFDR**
 Register Description: **Transmit FEAC Data Register**
 Register Address: **(0,2,4,6)C2h**

Bit #	15	14	13	12	11	10	9	8
Name	--	--	TFCB5	TFCB4	TFCB3	TFCB2	TFCB1	TFCB0
Default	0	0	0	0	0	0	0	0

Bit #	7	6	5	4	3	2	1	0
Name	--	--	TFCA5	TFCA4	TFCA3	TFCA2	TFCA1	TFCA0
Default	0	0	0	0	0	0	0	0

Bits 13 to 8: Transmit FEAC Code B (TFCB[5:0]) – These six bits are the transmit FEAC code B data to be stored inserted into codeword B. TFCB[5] is the LSB (last bit transmitted) of the FEAC code (C[6]), and TFCB[0] is the MSB (first bit transmitted) of the FEAC code (C[1]).

Bits 5 to 0: Transmit FEAC Code A (TFCA[5:0]) – These six bits are the transmit FEAC code A data to be stored inserted into codeword A. TFCA[5] is the LSB (last bit transmitted) of the FEAC code (C[6]), and TFCA[0] is the MSB (first bit transmitted) of the FEAC code (C[1]).

Register Name: **FEAC.TSR**
 Register Description: **FEAC Transmit Status Register**
 Register Address: **(0,2,4,6)C4h**

Bit #	15	14	13	12	11	10	9	8
Name	--	--	--	--	--	--	--	--

Bit #	7	6	5	4	3	2	1	0
Name	--	--	--	--	--	--	--	<u>TFI</u>

Bit 0: Transmit FEAC Idle (TFI) – When 0, the Transmit FEAC processor is sending a FEAC codeword. When 1, the Transmit FEAC processor is sending an Idle signal (all ones).

Register Name: **FEAC.TSRL**
 Register Description: **FEAC Transmit Status Register Latched**
 Register Address: **(0,2,4,6)C6h**

Bit #	15	14	13	12	11	10	9	8
Name	--	--	--	--	--	--	--	--

Bit #	7	6	5	4	3	2	1	0
Name	--	--	--	--	--	--	--	<u>TFIL</u>

Bit 0: Transmit FEAC Idle Latched (TFIL) – This bit is set when the TFI bit transitions from 0 to 1. Note: Immediately after a reset, this bit will be set to one.

Register Name: **FEAC.TSRIE**
 Register Description: **FEAC Transmit Status Register Interrupt Enable**
 Register Address: **(0,2,4,6)C8h**

Bit #	15	14	13	12	11	10	9	8
Name	--	--	--	--	--	--	--	--
Default	0	0	0	0	0	0	0	0

Bit #	7	6	5	4	3	2	1	0
Name	--	--	--	--	--	--	--	TFIIE
Default	0	0	0	0	0	0	0	0

Bit 0: Transmit FEAC Idle Interrupt Enable (TFIIE) – This bit enables an interrupt if the TFIL bit is set and the bit in [GLISRIE.PSRIE\[4:1\]](#) that corresponds to this port is set.

0 = interrupt disabled

1 = interrupt enabled

12.7.2 FEAC Receive Side Register Map

The receive side utilizes five registers.

Table 12-20. FEAC Receive Side Register Map

Address	Register	Register Description
(0,2,4,6)D0h	FEAC.RCR	FEAC Receive Control Register
(0,2,4,6)D2h	--	Unused
(0,2,4,6)D4h	FEAC.RSR	FEAC Receive Status Register
(0,2,4,6)D6h	FEAC.RSRL	FEAC Receive Status Register Latched
(0,2,4,6)D8h	FEAC.RSRIE	FEAC Receive Status Register Interrupt Enable
(0,2,4,6)DAh	--	Unused
(0,2,4,6)DCh	FEAC.RFDR	FEAC Receive FIFO Data Register
(0,2,4,6)DEh	--	Unused

12.7.2.1 Register Bit Descriptions

Register Name: **FEAC.RCR**
 Register Description: **FEAC Receive Control Register**
 Register Address: **(0,2,4,6)D0h**

Bit #	15	14	13	12	11	10	9	8
Name	--	--	--	--	--	--	--	--
Default	0	0	0	0	1	0	0	0

Bit #	7	6	5	4	3	2	1	0
Name	--	--	--	--	--	--	--	RFR
Default	0	0	0	0	0	0	0	0

Bit 0: Receive FEAC Reset (RFR) –When 0, the Receive FEAC Processor and Receive FEAC FIFO will resume normal operations. When 1, the Receive FEAC controller is reset. The FEAC FIFO is emptied, any transfer in progress is halted, and all incoming data is discarded.

Register Name: **FEAC.RSR**
 Register Description: **FEAC Receive Status Register**
 Register Address: **(0,2,4,6)D4h**

Bit #	15	14	13	12	11	10	9	8
Name	--	--	--	--	--	--	--	--
Bit #	7	6	5	4	3	2	1	0
Name	--	--	--	--	<u>RFFE</u>	--	<u>RFCD</u>	<u>RFI</u>

Bit 3: Receive FEAC FIFO Empty (RFFE) – When 0, the Receive FIFO contains at least one code. When 1, the Receive FIFO is empty.

Bit 1: Receive FEAC Codeword Detect (RFCD) – When 0, the Receive FEAC Processor is not currently receiving a FEAC codeword. When 1, the Receive FEAC Processor is currently receiving a FEAC codeword.

Bit 0: Receive FEAC Idle (RFI) – When 0, the Receive FEAC processor is not receiving a FEAC Idle signal (all ones). When 1, the Receive FEAC processor is receiving a FEAC Idle signal.

Register Name: **FEAC.RSRL**
 Register Description: **FEAC Receive Status Register Latched**
 Register Address: **(0,2,4,6)D6h**

Bit #	15	14	13	12	11	10	9	8
Name	--	--	--	--	--	--	--	--
Bit #	7	6	5	4	3	2	1	0
Name	--	--	--	--	--	<u>RFFOL</u>	<u>RFCDL</u>	<u>RFIL</u>

Bit 2: Receive FEAC FIFO Overflow Latched (RFFOL) – This bit is set when a Receive FIFO overflow condition occurs. An overflow condition results in a loss of data.

Bit 1: Receive FEAC Codeword Detect Latched (RFCDL) – This bit is set when the RFCD bit transitions from 0 to 1.

Bit 0: Receive FEAC Idle Latched (RFIL) – This bit is set when the RFI bit transitions from 0 to 1. Note: Immediately after a reset, this bit will be set to one.

Register Name: **FEAC.RSRIE**
 Register Description: **FEAC Receive Status Register Interrupt Enable**
 Register Address: **(0,2,4,6)D8h**

Bit #	15	14	13	12	11	10	9	8
Name	--	--	--	--	--	--	--	--
Default	0	0	0	0	0	0	0	0

Bit #	7	6	5	4	3	2	1	0
Name	--	--	--	--	--	RFFOIE	RFCDIE	RFIIE
Default	0	0	0	0	0	0	0	0

Bit 2: Receive FEAC FIFO Overflow Interrupt Enable (RFFOIE) – This bit enables an interrupt if the RFFOL bit is set and the bit in [GL.ISRIE](#).PSRIE[4:1] that corresponds to this port is set.

0 = interrupt disabled

1 = interrupt enabled

Bit 1: Receive FEAC Codeword Detect Interrupt Enable (RFCDIE) – This bit enables an interrupt if the RFCDL bit is set and the bit in [GL.ISRIE](#).PSRIE[4:1] that corresponds to this port is set.

0 = interrupt disabled

1 = interrupt enabled

Bit 0: Receive FEAC Idle Interrupt Enable (RFIIE) – This bit enables an interrupt if the RFIL bit is set and the bit in [GL.ISRIE](#).PSRIE[4:1] that corresponds to this port is set.

0 = interrupt disabled

1 = interrupt enabled

Register Name: **FEAC.RFDR**
 Register Description: **FEAC Receive FIFO Data Register**
 Register Address: **(0,2,4,6)DCh**

Bit #	15	14	13	12	11	10	9	8
Name	--	--	--	--	--	--	--	--
Default	0	0	0	0	0	0	0	0

Bit #	7	6	5	4	3	2	1	0
Name	<u>RFFI</u>	--	<u>RFF5</u>	<u>RFF4</u>	<u>RFF3</u>	<u>RFF2</u>	<u>RFF1</u>	<u>RFF0</u>
Default	0	0	0	0	0	0	0	0

Bit 7: Receive FEAC FIFO Data Invalid (RFFI) – When 0, the Receive FIFO data (RFF[5:0]) is valid. When 1, the Receive FIFO data is invalid (Receive FIFO is empty).

Bits 5 to 0: Receive FEAC FIFO Data (RFF[5:0]) – These six bits are the FEAC code data stored in the Receive FIFO. RFF[5] is the LSB (last bit received) of the FEAC code (C[6]), and RFF[0] is the MSB (first bit received) of the FEAC code (C[1]). The Receive FEAC FIFO data (RFF[5:0]) is updated when it is read (lower byte read).

12.8 Trail Trace

12.8.1 Trail Trace Transmit Side

The transmit side utilizes three registers. Register Map

Table 12-21. Transmit Side Trail Trace Register Map

Address	Register	Register Description
(0,2,4,6)E8h	TT.TCR	Trail Trace Transmit Control Register
(0,2,4,6)EAh	TT.TTIAR	Trail Trace Transmit Identifier Address Register
(0,2,4,6)ECh	TT.TIR	Trail Trace Transmit Identifier Register
(0,2,4,6)EEh	--	Unused

12.8.1.1 Register Bit Descriptions

Register Name: **TT.TCR**
 Register Description: **Trail Trace Transmit Control Register**
 Register Address: **(0,2,4,6)E8h**

Bit #	15	14	13	12	11	10	9	8
Name	--	--	--	--	--	--	--	--
Default	0	0	0	0	0	0	0	0

Bit #	7	6	5	4	3	2	1	0
Name	--	--	--	Reserved	TMAD	TIDLE	TDIE	TBRE
Default	0	0	0	0	0	0	0	0

Bit 3: Transmit Multi-frame Alignment Insertion Disable (TMAD) – When 0, multi-frame alignment signal (MAS) insertion is enabled, and the first bit transmitted of each trail trace byte is overwritten with an MAS bit. When 1, MAS insertion is disabled, and the trail trace bytes from the Transmit Data Storage are output without being modified.

Bit 2: Transmit Trail Trace Identifier Idle (TIDLE) – When 0, the programmed transmit trail trace identifier will be transmitted. When 1, all zeros will be transmitted.

Bit 1: Transmit Data Inversion Enable (TDIE) – When 0, the outgoing data from trail trace processing is output directly. When 1, the outgoing data from trail trace processing is inverted before being output.

Bit 0: Transmit Bit Reordering Enable (TBRE) – When 0, bit reordering is disabled (The first bit transmitted is the MSB *TT.TIR.TTD[7]* of the byte). When 1, bit reordering is enabled (The first bit transmitted is the LSB *TT.TIR.TTD[0]* of the byte).

Register Name: **TT.TTIAR**
 Register Description: **Trail Trace Transmit Identifier Address Register**
 Register Address: **(0,2,4,6)EAh**

Bit #	15	14	13	12	11	10	9	8
Name	--	--	--	--	--	--	--	--
Default	0	0	0	0	0	0	0	0

Bit #	7	6	5	4	3	2	1	0
Name	--	--	Reserved	Reserved	TTIA3	TTIA2	TTIA1	TTIA0
Default	0	0	0	0	0	0	0	0

Bits 3 to 0: Transmit Trail Trace Identifier Address (TTIA[3:0]) – These four bits indicate the transmit trail trace identifier byte to be read/written by the next memory access. Address 0h indicates the first byte of the transmit trail trace identifier. Note: The value of these bits increments with each transmit trail trace identifier memory access (when these bits are Fh, a memory access will return them to 0h).

Register Name: **TT.TIR**
 Register Description: **Trail Trace Transmit Identifier Register**
 Register Address: **(0,2,4,6)ECh**

Bit #	15	14	13	12	11	10	9	8
Name	--	--	--	--	--	--	--	--
Default	0	0	0	0	0	0	0	0

Bit #	7	6	5	4	3	2	1	0
Name	TTD7	TTD6	TTD5	TTD4	TTD3	TTD2	TTD1	TTD0
Default	0	0	0	0	0	0	0	0

Bits 7 to 0: Transmit Trail Trace Identifier Data (TTD[7:0]) – These eight bits are the transmit trail trace identifier data. The transmit trail trace identifier address will be incremented whenever these bits are read or written (when address location Fh is read or written, the address will return to 0h).

12.8.2 Trail Trace Receive Side Register Map

The receive side utilizes seven registers.

Table 12-22. Trail Trace Receive Side Register Map

Address	Register	Register Description
(0,2,4,6)F0h	TT.RCR	Trail Trace Receive Control Register
(0,2,4,6)F2h	TT.RIAR	Trail Trace Receive Identifier Address Register
(0,2,4,6)F4h	TT.RSR	Trail Trace Receive Status Register
(0,2,4,6)F6h	TT.RSRL	Trail Trace Receive Status Register Latched
(0,2,4,6)F8h	TT.RSRIE	Trail Trace Receive Status Register Interrupt Enable
(0,2,4,6)FAh	--	Unused
(0,2,4,6)FCh	TT.RIR	Trail Trace Receive Identifier Register
(0,2,4,6)FEh	TT.EIR	Trail Trace Expected Identifier Register

12.8.2.1 Register Bit Descriptions

Register Name: **TT.RCR**
 Register Description: **Trail Trace Receive Control Register**
 Register Address: **(0,2,4,6)F0h**

Bit #	15	14	13	12	11	10	9	8
Name	--	--	--	--	--	--	--	--
Default	0	0	0	0	0	0	0	0

Bit #	7	6	5	4	3	2	1	0
Name	--	--	Reserved	Reserved	RMAD	RETCE	RDIE	RBRE
Default	0	0	0	0	0	0	0	0

Bit 3: Receive Multi-frame Alignment Disable (RMAD) – When 0, multi-frame alignment is performed. When 1, multi-frame alignment is disabled and the trail trace bytes are stored starting with a random byte.

Bit 2: Receive Expected Trail Trace Comparison Enable (RETCE) – When 0, expected trail trace comparison is disabled. When 1, expected trail trace comparison is performed. Note: When the RMAD bit is one, expected trail trace comparison is disabled regardless of the setting of this bit.

Bit 1: Receive Data Inversion Enable (RDIE) – When 0, the incoming data is directly passed on for trail trace processing. When 1, the incoming data is inverted before being passed on for trail trace processing.

Bit 0: Receive Bit Reordering Enable (RBRE) – When 0, bit reordering is disabled (The first bit received is the MSB *TT.RIR.RTD[7]* of the byte). When 1, bit reordering is enabled (The first bit received is the LSB *TT.RIR.RTD[0]* of the byte).

Register Name: **TT.RTIAR**
 Register Description: **Trail Trace Receive Identifier Address Register**
 Register Address: **(0,2,4,6)F2h**

Bit #	15	14	13	12	11	10	9	8
Name	--	--	Reserved	Reserved	ETIA3	ETIA2	ETIA1	ETIA0
Default	0	0	0	0	0	0	0	0

Bit #	7	6	5	4	3	2	1	0
Name	--	--	Reserved	Reserved	RTIA3	RTIA2	RTIA1	RTIA0
Default	0	0	0	0	0	0	0	0

Bits 11 to 8: Expected Trail Trace Identifier Address (ETIA[3:0]) – These four bits indicate the expected trail trace identifier byte to be read/written by the next memory access. Address 0h indicates the first byte of the expected trail trace identifier. Note: The value of these bits increments with each expected trail trace identifier memory access (when these bits are Fh, a memory access will return them to 0h).

Bits 3 to 0: Receive Trail Trace Identifier Address (RTIA[3:0]) – These four bits indicate the receive trail trace identifier byte to be read by the next memory access. Address 0h indicates the first byte of the receive trail trace identifier. Note: The value of these bits increments with each received trail trace identifier memory access (when these bits are Fh, a memory access will return them to 0h).

Register Name: **TT.RSR**
 Register Description: **Trail Trace Receive Status Register**
 Register Address: **(0,2,4,6)F4h**

Bit #	15	14	13	12	11	10	9	8
Name	--	--	--	--	--	--	--	--

Bit #	7	6	5	4	3	2	1	0
Name	--	--	--	--	--	<u>RTIM</u>	<u>RTIU</u>	<u>RIDL</u>

Bit 2: Receive Trail Trace Identifier Mismatch (RTIM)

0 = Received and expected trail trace identifiers match.
 1 = Received and expected trail trace identifiers do not match; trail trace identifier mismatch (TIM) declared.

Bit 1: Receive Trail Trace Identifier Unstable (RTIU)

0 = Received trail trace identifier is not unstable
 1 = Received trail trace identifier is in an unstable condition (TIU); TIU is declared when eight consecutive trail trace identifiers are received that do not match either the receive trail trace identifier or the previously stored current trail trace identifier.

Bit 0: Receive Trail Trace Identifier Idle (RIDL)

0 = Received trail trace identifier is not in idle condition.
 1 = Received trail trace identifier is in idle condition. Idle condition is declared upon the reception of an all zeros trail trace identifier five consecutive times.

Register Name: **TT.RSRL**
 Register Description: **Trail Trace Receive Status Register Latched**
 Register Address: **(0,2,4,6)F6h**

Bit #	15	14	13	12	11	10	9	8
Name	--	--	--	--	--	--	--	--
Bit #	7	6	5	4	3	2	1	0
Name	--	--	--	--	<u>RTICL</u>	<u>RTIML</u>	<u>RTIUL</u>	<u>RIDLL</u>

Bit 3: Receive Trail Trace Identifier Change Latched (RTICL) – This bit is set when the receive trail trace identifier is updated.

Bit 2: Receive Trail Trace Identifier Mismatch Latched (RTIML) – This bit is set when the *TT.RSR.RTIM* bit transitions from 0 to 1.

Bit 1: Receive Trail Trace Identifier Unstable Latched (RTIUL) – This bit is set when the *TT.RSR.RTIU* bit transitions from 0 to 1.

Bit 0: Receive Trail Trace Identifier Idle Latched (RIDLL) – This bit is set when the *TT.RSR.RIDL* bit transitions from 0 to 1.

Register Name: **TT.RSRIE**
 Register Description: **Trail Trace Receive Status Register Interrupt Enable**
 Register Address: **(0,2,4,6)F8h**

Bit #	15	14	13	12	11	10	9	8
Name	--	--	--	--	--	--	--	--
Default	0	0	0	0	0	0	0	0
Bit #	7	6	5	4	3	2	1	0
Name	--	--	--	--	<u>RTICIE</u>	<u>RTIMIE</u>	<u>RTIUIE</u>	<u>RIDLIE</u>
Default	0	0	0	0	0	0	0	0

Bit 3: Receive Trail Trace Identifier Change Interrupt Enable (RTICIE) – This bit enables an interrupt if the *TT.RSRL.RTICL* bit is set and the bit in [GL.ISRIE.PSRIE\[4:1\]](#) that corresponds to this port is set.

0 = interrupt disabled
 1 = interrupt enabled

Bit 2: Receive Trail Trace Identifier Mismatch Interrupt Enable (RTIMIE) – This bit enables an interrupt if the *TT.RSRL.RTIML* bit is set and the bit in [GL.ISRIE.PSRIE\[4:1\]](#) that corresponds to this port is set.

0 = interrupt disabled
 1 = interrupt enabled

Bit 1: Receive Trail Trace Identifier Unstable Interrupt Enable (RTIUIE) – This bit enables an interrupt if the *TT.RSRL.RTIUL* bit is set and the bit in [GL.ISRIE.PSRIE\[4:1\]](#) that corresponds to this port is set.

0 = interrupt disabled
 1 = interrupt enabled

Bit 0: Receive Trail Trace Identifier Idle Interrupt Enable (RIDLIE) – This bit enables an interrupt if the *TT.RSRL.RIDLL* bit is set and the bit in [GL.ISRIE.PSRIE\[4:1\]](#) that corresponds to this port is set.

0 = interrupt disabled
 1 = interrupt enabled

Register Name: **TT.RIR**
 Register Description: **Trail Trace Receive Identifier Register**
 Register Address: **(0,2,4,6)FCh**

Bit #	15	14	13	12	11	10	9	8
Name	--	--	--	--	--	--	--	--
Default	0	0	0	0	0	0	0	0

Bit #	7	6	5	4	3	2	1	0
Name	<u>RTD7</u>	<u>RTD6</u>	<u>RTD5</u>	<u>RTD4</u>	<u>RTD3</u>	<u>RTD2</u>	<u>RTD1</u>	<u>RTD0</u>
Default	0	0	0	0	0	0	0	0

Bits 7 to 0: Receive Trail Trace Identifier Data (RTD[7:0]) – These eight bits are the receive trail trace identifier data. The receive trail trace identifier address will be incremented whenever these bits are read (when byte Fh is read, the address will return to 0h).

Register Name: **TT.EIR**
 Register Description: **Trail Trace Expected Identifier Register**
 Register Address: **(0,2,4,6)FEh**

Bit #	15	14	13	12	11	10	9	8
Name	--	--	--	--	--	--	--	--
Default	0	0	0	0	0	0	0	0

Bit #	7	6	5	4	3	2	1	0
Name	<u>ETD7</u>	<u>ETD6</u>	<u>ETD5</u>	<u>ETD4</u>	<u>ETD3</u>	<u>ETD2</u>	<u>ETD1</u>	<u>ETD0</u>
Default	0	0	0	0	0	0	0	0

Bits 7 to 0: Expected Trail Trace Identifier Data (ETD[7:0]) – These eight bits are the expected trail trace identifier data. The expected trail trace identifier address will be incremented whenever these bits are read or written (when byte Fh is read or written, the address will return to 0h).

12.9 DS3/E3 Framer

12.9.1 Transmit DS3

The transmit DS3 utilizes two registers.

Table 12-23. Transmit DS3 Framer Register Map

Address	Register	Register Description
(1,3,5,7)18h	T3.TCR	T3 Transmit Control Register
(1,3,5,7)1Ah	T3.TEIR	T3 Transmit Error Insertion Register
(1,3,5,7)1Ch	--	Reserved
(1,3,5,7)1Eh	--	Reserved

12.9.1.1 Register Bit Descriptions

Register Name: **T3.TCR**
 Register Description: **T3 Transmit Control Register**
 Register Address: **(1,3,5,7)18h**

Bit #	15	14	13	12	11	10	9	8
Name	--	--	--	PBGE	TIDLE	CBGD	--	--
Default	0	0	0	0	0	0	0	0

Bit #	7	6	5	4	3	2	1	0
Name	--	--	TFEBE	AFEDED	TRDI	ARDID	TFGC	TAIS
Default	0	0	0	0	0	0	0	0

Bit 12: P-bit Generation Enable (PBGE) – When 0, Transmit Frame Processor P-bit generation is disabled. If transmit frame generation is also disabled, the P-bit overhead periods in the incoming DS3 signal will be passed through to overhead insertion. When 1, Transmit Frame Processor P-bit generation is enabled. The P-bit overhead periods in the incoming DS3 signal will be overwritten even if transmit frame generation is disabled

Bit 11: Transmit DS3 Idle Signal (TIDLE) –

- 0 = Transmit DS3 Idle signal is not inserted
- 1 = Transmit DS3 Idle signal is inserted into the DS3 frame.

Bit 10: C-bit Generation Disable (CBGD) (M23 mode only) – When 0, Transmit Frame Processor C-bit generation is enabled. The C-bit overhead periods in the incoming M23 DS3 signal will be overwritten with zeros. When 1, Transmit Frame Processor C-bit generation is disabled. The C-bit overhead periods in the incoming M23 DS3 signal will be treated as payload, and passed through to overhead insertion. This bit is ignored in C-bit DS3 mode.

Bit 5: Transmit FEBE Error (TFEBE) – When automatic far-end block error generation is defeated (AFEDED = 1), the inverse of this bit is inserted into the bits C₄₁, C₄₂, and C₄₃. Note: a far-end block error value of zero (TFEBE=1) indicates a far-end block error. This bit is ignored in M23 DS3 mode.

Bit 4: Automatic FEBE Defeat (AFEDED) – When 0, a far-end block error is automatically generated based upon the receive C-bit parity errors or framing errors. When 1, a far-end block error is inserted from the register bit TFEBE. This bit is ignored in M23 DS3 mode.

Bit 3: Transmit RDI Alarm (TRDI) – When automatic RDI generation is defeated (ARDID = 1), the inverse of this bit is inserted into the X-bits (X₁ and X₂). Note: an RDI value of zero (TRDI=1) indicates an alarm.

Bit 2: Automatic RDI Defeat (ARDID) – When 0, the RDI is automatically generated based received DS3 alarms. When 1, the RDI is inserted from the register bit TRDI.

Bit 1: Transmit Frame Generation Control (TFGC) – When this bit is zero, the Transmit Frame Processor frame generation is enabled. The DS3 overhead positions in the incoming DS3 payload will be overwritten with the internally generated DS3 overhead. When this bit is one, the Transmit Frame Processor frame generation is disabled. The DS3 overhead positions in the incoming DS3 payload will be passed through to error insertion. Note: Frame generation will still overwrite the P-bits if PBGE = 1. Also, the DS3 overhead periods can still be overwritten by overhead insertion.

Bit 0: Transmit Alarm Indication Signal (TAIS) –

- 0 = Transmit Alarm Indication Signal is not inserted
- 1 = Transmit Alarm Indication Signal is inserted into data stream payload

Register Name: **T3.TEIR**
 Register Description: **T3 Transmit Error Insertion Register**
 Register Address: **(1,3,5,7)1Ah**

Bit #	15	14	13	12	11	10	9	8
Name	--	--	--	--	CCPEIE	CPEI	CFBEIE	FBEI
Default	0	0	0	0	0	0	0	0

Bit #	7	6	5	4	3	2	1	0
Name	Reserved	CPEIE	PEI	FEIC1	FEIC0	FEI	TSEI	MEIMS
Default	0	0	0	0	0	0	0	0

Bit 11: Continuous C-bit Parity Error Insertion Enable (CCPEIE) – When 0, single C-bit parity error insertion is enabled. When 1, continuous C-bit parity error insertion is enabled, and C-bit parity errors will be transmitted continuously if CPEI is high.

Bit 10: C-bit Parity Error Insertion Enable (CPEI) – When 0, C-bit parity error insertion is disabled. When 1, C-bit parity error insertion is enabled.

Bit 9: Continuous Far-End Block Error Insertion Enable (CFBEIE) – When 0, single far-end block error insertion is enabled. When 1, continuous far-end block error insertion is enabled, and far-end block errors will be transmitted continuously if FBEI is high.

Bit 8: Far-End Block Error Insertion Enable (FBEI) – When 0, far-end block error insertion is disabled. When 1, far-end block error insertion is enabled.

Bit 6: Continuous P-bit Parity Error Insertion Enable (CPEIE) – When 0, single P-bit parity error insertion is enabled. When 1, continuous P-bit parity error insertion is enabled, and P-bit parity errors will be transmitted continuously if PEI is high.

Bit 5: P-bit Parity Error Insertion Enable (PEI) – When 0, P-bit parity error insertion is disabled. When 1, P-bit parity error insertion is enabled.

Bits 4 to 3: Framing Error Insertion Control (FEIC[1:0]) – These two bits control the framing error event to be inserted.

- 00 = F-bit error.
- 01 = M-bit error.
- 10 = SEF error.
- 11 = OOMF error.

Bit 2: Framing Error Insertion Enable (FEI) – When 0, framing error insertion is disabled. When 1, framing error insertion is enabled.

Bit 1: Transmit Single Error Insert (TSEI) – This bit causes an error of the enabled type(s) to be inserted in the transmit data stream if manual error insertion is disabled (MEIMS = 0). A 0 to 1 transition causes a single error to be inserted. For a second error to be inserted, this bit must be set to 0, and back to 1. Note: If MEIMS is low, and this bit transitions more than once between error insertion opportunities, only one error will be inserted.

Bit 0: Manual Error Insert Mode Select (MEIMS) – When 0, error insertion is initiated by the TSEI register bit. When 1, error insertion is initiated by the transmit manual error insertion signal (TMEI). Note: If TMEI or TSEI is one, changing the state of this bit may cause an error to be inserted.

12.9.2 Receive DS3 Register Map

The receive DS3 utilizes eleven registers. Two registers are shared for C-Bit and M23 DS3 modes. The M23 DS3 mode does not use the RFEBCR or RCPECR count registers.

Table 12-24. Receive DS3 Framer Register Map

Address	Register	Register Description
(1,3,5,7)20h	T3.RCR	T3 Receive Control Register
(1,3,5,7)22h	--	Reserved
(1,3,5,7)24h	T3.RSR1	T3 Receive Status Register #1
(1,3,5,7)26h	T3.RSR2	T3 Receive Status Register #2
(1,3,5,7)28h	T3.RSRL1	T3 Receive Status Register Latched #1
(1,3,5,7)2Ah	T3.RSRL2	T3 Receive Status Register Latched #2
(1,3,5,7)2Ch	T3.RSRIE1	T3 Receive Status Register Interrupt Enable #1
(1,3,5,7)2Eh	T3.RSRIE2	T3 Receive Status Register Interrupt Enable #2
(1,3,5,7)30h	--	Reserved
(1,3,5,7)32h	--	Reserved
(1,3,5,7)34h	T3.RFEBCR	T3 Receive Framing Error Count Register
(1,3,5,7)36h	T3.RPEBCR	T3 Receive P-bit Parity Error Count Register
(1,3,5,7)38h	T3.RFBEBCR	T3 Receive Far-End Block Error Count Register
(1,3,5,7)3Ah	T3.RCPEBCR	T3 Receive C-bit Parity Error Count Register
(1,3,5,7)3Ch	--	Unused
(1,3,5,7)3Eh	--	Unused

12.9.2.1 Register Bit Descriptions

Register Name: **T3.RCR**
 Register Description: **T3 Receive Control Register**
 Register Address: **(1,3,5,7)20h**

Bit #	15	14	13	12	11	10	9	8
Name	Reserved	COVHD	MAOD	MDAISI	AAISD	ECC	FECC1	FECC0
Default	0	0	0	0	0	0	0	0

Bit #	7	6	5	4	3	2	1	0
Name	RAILE	RAILD	RAIOD	RAIAD	ROMD	LIP1	LIP0	FRSYNC
Default	0	0	0	0	0	0	0	0

Bit 14: C-bit Overhead Masking Disable (COVHD) – When 0, the C-bit positions will be marked as overhead (RDENn=0). When 1, the C-bit positions will be marked as data (RDENn=1). This bit is ignored in C-bit DS3 mode or when the ROMD bit is set to one.

Bit 13: Multi-frame Alignment OOF Disable (MAOD) – When 0, an OOF condition is declared whenever an OOMF or SEF condition is declared. When 1, an OOF condition is declared only when an SEF condition is declared.

Bit 12: Manual Downstream AIS Insertion (MDAISI) – When 0, manual downstream AIS insertion is disabled. When 1, manual downstream AIS insertion is enabled.

Bit 11: Automatic Downstream AIS Disable (AAISD) – When 0, the presence of an LOS, OOF, or AIS condition will cause downstream AIS to be inserted. When 1, the presence of an LOS, OOF, or AIS condition will not cause downstream AIS to be inserted.

Bit 10: Error Count Control (ECC) – When 0, framing errors, P-bit parity errors, C-bit parity errors, and far-end block errors will not be counted if an OOF or AIS condition is present. P-bit parity errors, C-bit parity errors, and far-end block errors will also not be counted during the DS3 frame in which an OOF condition is terminated, and the next DS3 frame. When 1, framing errors, P-bit parity errors, C-bit parity errors, and far-end block errors will be counted regardless of the presence of an OOF or AIS condition.

Bits 9 to 8: Framing Error Count Control (FECC[1:0]) – These two bits control the type of framing error events that are counted.

00 = count OOF occurrences (counted regardless of the setting of the ECC bit).

01 = count M bit and F bit errors.

10 = count only F bit errors.

11 = count only M bit errors.

Bit 7: Receive Alarm Indication on LOF Enable (RAILE) – When 0, an LOF condition does not affect the receive alarm indication signal (RAI). When 1, an LOF condition will cause the transmit DS3 X-bits to be set to zero if transmit automatic RDI is enabled.

Bit 6: Receive Alarm Indication on LOS Disable (RAILD) – When 0, an LOS condition will cause the transmit DS3 X-bits to be set to zero if transmit automatic RDI is enabled. When 1, an LOS condition does not affect the RAI signal.

Bit 5: Receive Alarm Indication on SEF Disable (RAIOD) – When 0, an SEF condition will cause the transmit DS3 X-bits to be set to zero if transmit automatic RDI is enabled. When 1, an SEF condition does not affect the RAI signal.

Bit 4: Receive Alarm Indication on AIS Disable (RAIAD) – When 0, an AIS condition will cause the transmit DS3 X-bits to be set to zero if transmit automatic RDI is enabled. When 1, an AIS condition does not affect the RAI signal.

Bit 3: Receive Overhead Masking Disable (ROMD) – When 0, the DS3 overhead positions in the outgoing DS3 payload will be marked as overhead by RDENN. When 1, the DS3 overhead positions in the outgoing DS3 payload will be marked as payload data by RDENN. When this bit is set to one, the COVHD bit is ignored.

Bits 2 to 1: LOF Integration Period (LIP[1:0]) – These two bits determine the OOF integration period for declaring LOF.

00 = OOF is integrated for 3 ms before declaring LOF

01 = OOF is integrated for 2 ms before declaring LOF

10 = OOF is integrated for 1 ms before declaring LOF.

11 = LOF is declared at the same time as OOF.

Bit 0: Force Framer Resynchronization (FRSYNC) – A 0 to 1 transition forces an OOF, SEF, and OOMF condition. The bit must be cleared and set to one again to force another resynchronization

Register Name: **T3.RSR1**
 Register Description: **T3 Receive Status Register #1**
 Register Address: **(1,3,5,7)24h**

Bit #	15	14	13	12	11	10	9	8
Name	<u>Reserved</u>	<u>Reserved</u>	--	<u>Reserved</u>	<u>T3FM</u>	<u>AIC</u>	<u>IDLE</u>	<u>RUA1</u>
Bit #	7	6	5	4	3	2	1	0
Name	<u>OOMF</u>	<u>SEF</u>	--	<u>LOF</u>	<u>RDI</u>	<u>AIS</u>	<u>OOF</u>	<u>LOS</u>

Bit 11: T3 Framing Format Mismatch (T3FM) – This bit indicates the DS3 framer is programmed for a framing format (C-bit or M23) that is different than the format indicated by the incoming DS3 signal.

Bit 10: Application Identification Channel (AIC) – This bit indicates the current state of the Application Identification Channel (AIC) from the C₁₁ bit. AIC = 1 is C-bit mode, AIC = 0 is M23 mode.

Bit 9: DS3 Idle Signal (IDLE) – When 0, the receive frame processor is not in a **DS3** idle signal (Idle) condition. When 1, the receive frame processor is in an Idle condition.

Bit 8: Receive Unframed All 1's (RUA1) – When 0, the receive frame processor is not in a receive unframed all 1's (RUA1) condition. When 1, the receive frame processor is in an RUA1 condition.

Bit 7: Out Of Multi-frame (OOMF) – When 0, the receive frame processor is not in an out of multi-frame (OOMF) condition. When 1, the receive frame processor is in an OOMF condition.

Bit 6: Severely Errored Frame (SEF) – When 0, the receive frame processor is not in a severely errored frame (SEF) condition. When 1, the receive frame processor is in an SEF condition.

Bit 4: Loss Of Frame (LOF) – When 0, the receive framer is not in a loss of frame (LOF) condition. When 1, the receive frame processor is in an LOF condition.

Bit 3: Remote Defect Indication (RDI) – This bit indicates the current state of the remote defect indication (RDI)

Bit 2: Alarm Indication Signal (AIS) – When 0, the receive frame processor is not in an alarm indication signal (AIS) condition. When 1, the receive frame processor is in an AIS condition.

Bit 1: Out Of Frame (OOF) – When 0, the receive framer is not in an out of frame (OOF) condition. When 1, the receive frame processor is in an OOF condition.

Bit 0: Loss Of Signal (LOS) – When 0, the receive framer is not in a loss of signal (LOS) condition. When 1, the receive framer is in an LOS condition.

Register Name: **T3.RSR2**
 Register Description: **T3 Receive Status Register #2**
 Register Address: **(1,3,5,7)26h**

Bit #	15	14	13	12	11	10	9	8
Name	--	--	--	--	--	--	--	--
Bit #	7	6	5	4	3	2	1	0
Name	--	--	--	--	<u>CPEC</u>	<u>FBEC</u>	<u>PEC</u>	<u>FEC</u>

Bit 3: C-bit Parity Error Count (CPEC) – When 0, the C-bit parity error count is zero. When 1, the C-bit parity error count is one or more. This bit is set to zero in M23 DS3 mode.

Bit 2: Remote Error Indication Count (FBEC) – When 0, the remote error indication count is zero. When 1, the remote error indication count is one or more. This bit is set to zero in M23 DS3 mode.

Bit 1: P-bit Parity Error Count (PEC) – When 0, the P-bit parity error count is zero. When 1, the P-bit parity error count is one or more.

Bit 0: Framing Error Count (FEC) – When 0, the framing error count is zero. When 1, the framing error count is one or more. The type of framing error event counted is determined by [T3.RCR.FECC\[1:0\]](#)

Register Name: **T3.RSRL1**
 Register Description: **T3 Receive Status Register Latched #1**
 Register Address: **(1,3,5,7)28h**

Bit #	15	14	13	12	11	10	9	8
Name	<u>Reserved</u>	<u>Reserved</u>	<u>Reserved</u>	<u>Reserved</u>	<u>T3FML</u>	<u>AICL</u>	<u>IDLEL</u>	<u>RUA1L</u>
Bit #	7	6	5	4	3	2	1	0
Name	<u>OOMFL</u>	<u>SEFL</u>	<u>COFAL</u>	<u>LOFL</u>	<u>RAIL</u>	<u>AISL</u>	<u>OOFL</u>	<u>LOSL</u>

Bit 11: T3 Framing Format Mismatch Latched (T3FML) – This bit is set when the T3FM bit transitions from zero to one.

Bit 10: Application Identification Channel Change Latched (AICL) – This bit is set when the AIC bit changes state.

Bit 9: DS3 Idle Signal Change Latched (IDLEL) – This bit is set when the IDLE bit changes state.

Bit 8: Receive Unframed All 1's Change Latched (RUA1L) – This bit is set when the RUA1 bit changes state.

Bit 7: Out Of Multi-frame Change Latched (OOMFL) – This bit is set when the OOMF bit changes state.

Bit 6: Severely Errored Frame Change Latched (SEFL) – This bit is set when the SEF bit changes state.

Bit 5: Change Of Frame Alignment Latched (COFAL) – This bit is set when the data path frame counters are updated with a new DS3 frame alignment that is different from the previous DS3 frame alignment.

Bit 4: Loss Of Frame Change Latched (LOFL) – This bit is set when the LOF bit changes state.

Bit 3: Remote Defect Indication Change Latched (RDIL) – This bit is set when the RDI bit changes state.

Bit 2: Alarm Indication Signal Change Latched (AISL) – This bit is set when the AIS bit changes state.

Bit 1: Out Of Frame Change Latched (OOFL) – This bit is set when the OOF bit changes state.

Bit 0: Loss Of Signal Change Latched (LOSL) – This bit is set when the LOS bit changes state.

Register Name: **T3.RSRL2**
 Register Description: **T3 Receive Status Register Latched #2**
 Register Address: **(1,3,5,7)2Ah**

Bit #	15	14	13	12	11	10	9	8
Name	--	--	--	--	<u>CPEL</u>	<u>FBEL</u>	<u>PEL</u>	<u>FEL</u>
Bit #	7	6	5	4	3	2	1	0
Name	--	--	--	--	<u>CPECL</u>	<u>FBECL</u>	<u>PECL</u>	<u>FECL</u>

Bit 11: C-bit Parity Error Latched (CPEL) – This bit is set when a C-bit parity error is detected. This bit is set to zero in M23 DS3 mode.

Bit 10: Remote Error Indication Latched (FBEL) – This bit is set when a far-end block error is detected. This bit is set to zero in M23 DS3 mode.

Bit 9: P-bit Parity Error Latched (PEL) – This bit is set when a P-bit parity error is detected.

Bit 8: Framing Error Latched (FEL) – This bit is set when a framing error is detected. The type of framing error event that causes this bit to be set is determined by [T3.RCR.FECC\[1:0\]](#)

Bit 3: C-bit Parity Error Count Latched (CPECL) – This bit is set when the CPEC bit transitions from zero to one. This bit is set to zero in M23 DS3 mode.

Bit 2: Remote Error Indication Count Latched (FBECL) – This bit is set when the FBEC bit transitions from zero to one. This bit is set to zero in M23 DS3 mode.

Bit 1: P-bit Parity Error Count Latched (PECL) – This bit is set when the PEC bit transitions from zero to one.

Bit 0: Framing Error Count Latched (FECL) – This bit is set when the FEC bit transitions from zero to one.

Register Name: **T3.RSRIE1**
 Register Description: **T3 Receive Status Register Interrupt Enable #1**
 Register Address: **(1,3,5,7)2Ch**

Bit #	15	14	13	12	11	10	9	8
Name	Reserved	Reserved	Reserved	Reserved	T3FMIE	AICIE	IDLEIE	RUA1IE
Default	0	0	0	0	0	0	0	0

Bit #	7	6	5	4	3	2	1	0
Name	OOMFIE	SEFIE	COFAIE	LOFIE	RAIIE	AISIE	OOFIE	LOSIE
Default	0	0	0	0	0	0	0	0

Bit 11: T3 Framing Format Mismatch Interrupt Enable (T3FMIE) – This bit enables an interrupt if the T3FML bit is set and the bit in [GL.ISRIE.PSRIE\[4:1\]](#) that corresponds to this port is set.

0 = interrupt disabled
 1 = interrupt enabled

Bit 10: Application Identification Channel Interrupt Enable (AICIE) – This bit enables an interrupt if the AICL bit is set and the bit in [GL.ISRIE.PSRIE\[4:1\]](#) that corresponds to this port is set.

0 = interrupt disabled
 1 = interrupt enabled

Bit 9: DS3 Idle Signal Change Interrupt Enable (IDLEIE) – This bit enables an interrupt if the IDLEL bit is set and the bit in [GL.ISRIE.PSRIE\[4:1\]](#) that corresponds to this port is set.

0 = interrupt disabled
 1 = interrupt enabled

Bit 8: Receive Unframed All 1's Interrupt Enable (RUA1IE) – This bit enables an interrupt if the RUA1L bit is set and the bit in [GL.ISRIE.PSRIE\[4:1\]](#) that corresponds to this port is set.

0 = interrupt disabled
 1 = interrupt enabled

Bit 7: Out Of Multi-frame Interrupt Enable (OOMFIE) – This bit enables an interrupt if the OOMFL bit is set and the bit in [GL.ISRIE.PSRIE\[4:1\]](#) that corresponds to this port is set.

0 = interrupt disabled
 1 = interrupt enabled

Bit 6: Severely Errored Frame Interrupt Enable (SEFIE) – This bit enables an interrupt if the SEFL bit is set and the bit in [GL.ISRIE.PSRIE\[4:1\]](#) that corresponds to this port is set.

0 = interrupt disabled
 1 = interrupt enabled

Bit 5: Change Of Frame Alignment Interrupt Enable (COFAIE) – This bit enables an interrupt if the COFAL bit is set and the bit in [GL.ISRIE.PSRIE\[4:1\]](#) that corresponds to this port is set.

0 = interrupt disabled
 1 = interrupt enabled

Bit 4: Loss Of Frame Interrupt Enable (LOFIE) – This bit enables an interrupt if the LOFL bit is set and the bit in [GL.ISRIE.PSRIE\[4:1\]](#) that corresponds to this port is set.

0 = interrupt disabled
 1 = interrupt enabled

Bit 3: Remote Defect Indication Interrupt Enable (RDIIE) – This bit enables an interrupt if the RDIL bit is set and the bit in [GL.ISRIE.PSRIE\[4:1\]](#) that corresponds to this port is set.

0 = interrupt disabled
 1 = interrupt enabled

Bit 2: Alarm Indication Signal Interrupt Enable (AISIE) – This bit enables an interrupt if the AISL bit is set and the bit in [GL.ISRIE](#).PSRIE[4:1] that corresponds to this port is set.

0 = interrupt disabled
1 = interrupt enabled

Bit 1: Out Of Frame Interrupt Enable (OOFIE) – This bit enables an interrupt if the OOFL bit is set and the bit in [GL.ISRIE](#).PSRIE[4:1] that corresponds to this port is set.

0 = interrupt disabled
1 = interrupt enabled

Bit 0: Loss Of Signal Interrupt Enable (LOSIE) – This bit enables an interrupt if the LOSL bit is set and the bit in [GL.ISRIE](#).PSRIE[4:1] that corresponds to this port is set.

0 = interrupt disabled
1 = interrupt enabled

Register Name: **T3.RSRIE2**
Register Description: **T3 Receive Status Register Interrupt Enable #2**
Register Address: **(1,3,5,7)2Eh**

Bit #	15	14	13	12	11	10	9	8
Name	--	--	--	--	CPEIE	FBEIE	PEIE	FEIE
Default	0	0	0	0	0	0	0	0

Bit #	7	6	5	4	3	2	1	0
Name	--	--	--	--	CPECIE	FBECIE	PECIE	FECIE
Default	0	0	0	0	0	0	0	0

Bit 11: C-bit Parity Error Interrupt Enable (CPEIE) – This bit enables an interrupt if the CPEL bit is set and the bit in [GL.ISRIE](#).PSRIE[4:1] that corresponds to this port is set.

0 = interrupt disabled
1 = interrupt enabled

Bit 10: Remote Error Interrupt Enable (FBEIE) – This bit enables an interrupt if the FBEL bit is set and the bit in [GL.ISRIE](#).PSRIE[4:1] that corresponds to this port is set.

0 = interrupt disabled
1 = interrupt enabled

Bit 9: P-bit Parity Error Interrupt Enable (PEIE) – This bit enables an interrupt if the PEL bit is set and the bit in [GL.ISRIE](#).PSRIE[4:1] that corresponds to this port is set.

0 = interrupt disabled
1 = interrupt enabled

Bit 8: Framing Error Interrupt Enable (FEIE) – This bit enables an interrupt if the FEL bit is set and the bit in [GL.ISRIE](#).PSRIE[4:1] that corresponds to this port is set.

0 = interrupt disabled
1 = interrupt enabled

Bit 3: C-bit Parity Error Count Interrupt Enable (CPECIE) – This bit enables an interrupt if the CPECL bit is set and the bit in [GL.ISRIE](#).PSRIE[4:1] that corresponds to this port is set.

0 = interrupt disabled
1 = interrupt enabled

Bit 2: Far-End Block Error Count Interrupt Enable (FBECIE) – This bit enables an interrupt if the FBECL bit is set and the bit in [GL.ISRIE](#).PSRIE[4:1] that corresponds to this port is set.

0 = interrupt disabled
1 = interrupt enabled

Bit 1: P-bit Parity Error Count Interrupt Enable (PECIE) – This bit enables an interrupt if the PECL bit is set and the bit in [GL.ISRIE](#).PSRIE[4:1] that corresponds to this port is set.

0 = interrupt disabled
1 = interrupt enabled

Bit 0: Framing Error Count Interrupt Enable (FECIE) – This bit enables an interrupt if the FECL bit is set and the bit in [GL.ISRIE](#).PSRIE[4:1] that corresponds to this port is set.

0 = interrupt disabled
1 = interrupt enabled

Register Name: **T3.RFECR**
Register Description: **T3 Receive Framing Error Count Register**
Register Address: **(1,3,5,7)34h**

Bit #	15	14	13	12	11	10	9	8
Name	<u>FE15</u>	<u>FE14</u>	<u>FE13</u>	<u>FE12</u>	<u>FE11</u>	<u>FE10</u>	<u>FE9</u>	<u>FE8</u>
Default	0	0	0	0	0	0	0	0

Bit #	7	6	5	4	3	2	1	0
Name	<u>FE7</u>	<u>FE6</u>	<u>FE5</u>	<u>FE4</u>	<u>FE3</u>	<u>FE2</u>	<u>FE1</u>	<u>FE0</u>
Default	0	0	0	0	0	0	0	0

Bits 15 to 0: Framing Error Count (FE[15:0]) – These sixteen bits indicate the number of framing error events on the incoming **DS3** data stream. This register is updated via the PMU signal (see Section [10.4.5](#)).

Register Name: **T3.RPECR**
Register Description: **T3 Receive P-bit Parity Error Count Register**
Register Address: **(1,3,5,7)36h**

Bit #	15	14	13	12	11	10	9	8
Name	<u>PE15</u>	<u>PE14</u>	<u>PE13</u>	<u>PE12</u>	<u>PE11</u>	<u>PE10</u>	<u>PE9</u>	<u>PE8</u>
Default	0	0	0	0	0	0	0	0

Bit #	7	6	5	4	3	2	1	0
Name	<u>PE7</u>	<u>PE6</u>	<u>PE5</u>	<u>PE4</u>	<u>PE3</u>	<u>PE2</u>	<u>PE1</u>	<u>PE0</u>
Default	0	0	0	0	0	0	0	0

Bits 15 to 0: P-bit Parity Error Count (PE[15:0]) – These sixteen bits indicate the number of P-bit parity errors detected on the incoming **DS3** data stream. This register is updated via the PMU signal (see Section [10.4.5](#)).

Register Name: **T3.RFBECR**
 Register Description: **T3 Receive Far-End Block Error Count Register**
 Register Address: **(1,3,5,7)38h**

Bit #	15	14	13	12	11	10	9	8
Name	<u>FBE15</u>	<u>FBE14</u>	<u>FBE13</u>	<u>FBE12</u>	<u>FBE11</u>	<u>FBE10</u>	<u>FBE9</u>	<u>FBE8</u>
Default	0	0	0	0	0	0	0	0

Bit #	7	6	5	4	3	2	1	0
Name	<u>FBE7</u>	<u>FBE6</u>	<u>FBE5</u>	<u>FBE4</u>	<u>FBE3</u>	<u>FBE2</u>	<u>FBE1</u>	<u>FBE0</u>
Default	0	0	0	0	0	0	0	0

Bits 15 to 0: Far-End Block Error Count (FBE[15:0]) – These sixteen bits indicate the number of far-end block errors detected on the incoming DS3 data stream. The associated counter will not increment in M23 DS3 mode. This register is updated via the PMU signal (see Section [10.4.5](#)).

Register Name: **T3.RCPECR**
 Register Description: **T3 Receive C-bit Parity Error Count Register**
 Register Address: **(1,3,5,7)3Ah**

Bit #	15	14	13	12	11	10	9	8
Name	<u>CPE15</u>	<u>CPE14</u>	<u>CPE13</u>	<u>CPE12</u>	<u>CPE11</u>	<u>CPE10</u>	<u>CPE9</u>	<u>CPE8</u>
Default	0	0	0	0	0	0	0	0

Bit #	7	6	5	4	3	2	1	0
Name	<u>CPE7</u>	<u>CPE6</u>	<u>CPE5</u>	<u>CPE4</u>	<u>CPE3</u>	<u>CPE2</u>	<u>CPE1</u>	<u>CPE0</u>
Default	0	0	0	0	0	0	0	0

Bits 15 to 0: C-bit Parity Error Count (CPE[15:0]) – These sixteen bits indicate the number of C-bit parity errors detected on the incoming DS3 data stream. The associated counter will not increment in M23 DS3 mode. This register is updated via the PMU signal (see Section [10.4.5](#)).

12.9.3 Transmit G.751 E3

The transmit G.751 E3 utilizes two registers.

12.9.3.1 Register Map

Table 12-25. Transmit G.751 E3 Framer Register Map

Address	Register	Register Description
(1,3,5,7)18h	E3G751.TCR	E3 G.751 Transmit Control Register
(1,3,5,7)1Ah	E3G751.TEIR	E3 G.751 Transmit Error Insertion Register
(1,3,5,7)1Ch	--	Reserved
(1,3,5,7)1Eh	--	Reserved

12.9.3.2 Register Bit Descriptions

Register Name: **E3G751.TCR**
 Register Description: **E3 G.751 Transmit Control Register**
 Register Address: **(1,3,5,7)18h**

Bit #	15	14	13	12	11	10	9	8
Name	Reserved	--	--	Reserved	Reserved	Reserved	TNBC1	TNBC0
Default	0	0	0	0	0	0	0	0

Bit #	7	6	5	4	3	2	1	0
Name	--	--	Reserved	Reserved	TABC1	TABC0	TFGC	TAIS
Default	0	0	0	0	0	0	0	0

Bits 9 to 8: Transmit N Bit Control (TNBC[1:0]) – These two bits control the source of the N bit.

- 00 = 1
- 01 = transmit data from HDLC controller.
- 10 = transmit data from FEAC controller.
- 11 = 0

Note: If TNBC[1:0] is 10 and TABC[1:0] is 01, both the N bit and A bit will carry the same transmit FEAC controller (one bit per frame period), however, the N bit and A bit in the same frame may or may not be equal.

Bits 3 to 2: Transmit A Bit Control (TABC[1:0]) – These two bits control the source of the A bit.

- 00 = automatically generated based upon received E3 alarms.
- 01 = transmit from the FEAC controller.
- 10 = 0
- 11 = 1

Note: If TABC[1:0] is 01 and TNBC[1:0] is 10, both the A bit and N bit will carry the same transmit FEAC controller (one bit per frame period), however, the A bit and N bit in the same frame may or may not be equal.

Bit 1: Transmit Frame Generation Control (TFGC) – When this bit is zero, the Transmit Frame Processor frame generation is enabled. The E3 overhead positions in the incoming E3 payload will be overwritten with the internally generated E3 overhead. When this bit is one, the Transmit Frame Processor frame generation is disabled. The E3 overhead positions in the incoming E3 payload will be passed through to error insertion. Note: The E3 overhead periods can still be overwritten by overhead insertion.

Bit 0: Transmit Alarm Indication Signal (TAIS) – When 0, the normal signal is transmitted. When 1, the output E3 data stream is forced to all ones (AIS).

Register Name: **E3G751.TEIR**
 Register Description: **E3 G.751 Transmit Error Insertion Register**
 Register Address: **(1,3,5,7)1Ah**

Bit #	15	14	13	12	11	10	9	8
Name	--	--	--	--	Reserved	Reserved	Reserved	Reserved
Default	0	0	0	0	0	0	0	0

Bit #	7	6	5	4	3	2	1	0
Name	Reserved	Reserved	Reserved	FEIC1	FEIC0	FEI	TSEI	MEIMS
Default	0	0	0	0	0	0	0	0

Bits 4 to 3: Framing Error Insert Control (FEIC[1:0]) – These two bits control the framing error event to be inserted.

- 00 = single bit error in one frame.
- 01 = word error in one frame.
- 10 = single bit error in four consecutive frames.
- 11 = word error in four consecutive frames.

Bit 2: Framing Error Insertion Enable (FEI) – When 0, framing error insertion is disabled. When 1, framing error insertion is enabled.

Bit 1: Transmit Single Error Insert (TSEI) – This bit causes an error of the enabled type(s) to be inserted in the transmit data stream if manual error insertion is disabled (MEIMS = 0). A 0 to 1 transition causes a single error to be inserted. For a second error to be inserted, this bit must be set to 0, and back to 1. Note: If MEIMS is low, and this bit transitions more than once between error insertion opportunities, only one error will be inserted.

Bit 0: Manual Error Insert Mode Select (MEIMS) – When 0, error insertion is initiated by the TSEI register bit. When 1, error insertion is initiated by the transmit manual error insertion signal (TMEI). Note: If TMEI or TSEI is one, changing the state of this bit may cause an error to be inserted.

12.9.4 Receive G.751 E3 Register Map

The receive G.751 E3 utilizes eight registers.

Table 12-26. Receive G.751 E3 Framer Register Map

Address	Register	Register Description
(1,3,5,7)20h	E3G751.RCR	E3 G.751 Receive Control Register
(1,3,5,7)22h	--	Reserved
(1,3,5,7)24h	E3G751.RSR1	E3 G.751 Receive Status Register #1
(1,3,5,7)26h	E3G751.RSR2	E3 G.751 Receive Status Register #2
(1,3,5,7)28h	E3G751.RSRL1	E3 G.751 Receive Status Register Latched #1
(1,3,5,7)2Ah	E3G751.RSRL2	E3 G.751 Receive Status Register Latched #2
(1,3,5,7)2Ch	E3G751.RSRIE1	E3 G.751 Receive Status Register Interrupt Enable #1
(1,3,5,7)2Eh	E3G751.RSRIE2	E3 G.751 Receive Status Register Interrupt Enable #2
(1,3,5,7)30h	--	Reserved
(1,3,5,7)32h	--	Reserved
(1,3,5,7)34h	E3G751.RFECR	E3 G.751 Receive Framing Error Count Register
(1,3,5,7)36h	--	Reserved
(1,3,5,7)38h	--	Reserved
(1,3,5,7)3Ah	--	Reserved
(1,3,5,7)3Ch	--	Unused
(1,3,5,7)3Eh	--	Unused

12.9.4.1 Register Bit Descriptions

Register Name: **E3G751.RCR**
 Register Description: **E3 G.751 Receive Control Register**
 Register Address: **(1,3,5,7)20h**

Bit #	15	14	13	12	11	10	9	8
Name	Reserved	Reserved	DLS	MDAISI	AAISD	ECC	FECC1	FECC0
Default	0	0	0	0	0	0	0	0

Bit #	7	6	5	4	3	2	1	0
Name	RAILE	RAILD	RAIOD	RAIAD	ROMD	LIP1	LIP0	FRSYNC
Default	0	0	0	0	0	0	0	0

Bit 13: Receive FEAC Data Link Source (DLS) – When 0, the receive FEAC controller will be sourced from the N bit. When 1, the receive FEAC controller will be sourced from the A bit.

Bit 12: Manual Downstream AIS Insertion (MDAISI) – When 0, manual downstream AIS insertion is disabled. When 1, manual downstream AIS insertion is enabled.

Bit 11: Automatic Downstream AIS Disable (AAISD) – When 0, the presence of an LOS, OOF, or AIS condition will cause downstream AIS to be inserted. When 1, the presence of an LOS, OOF, or AIS condition will not cause downstream AIS to be inserted.

Bit 10: Error Count Control (ECC) – When 0, framing errors will not be counted if an OOF or AIS condition is present. When 1, framing errors will be counted regardless of the presence of an OOF or AIS condition.

Bits 9 to 8: Framing Error Count Control (FECC[1:0]) – These two bits control the type of framing error events that are counted.

- 00 = count OOF occurrences (counted regardless of the setting of the ECC bit)..
- 01 = count each bit error in the FAS (up to 10 per frame).
- 10 = count frame alignment signal (FAS) errors (up to one per frame).
- 11 = reserved

Bit 7: Receive Alarm Indication on LOF Enable (RAILE) – When 0, an LOF condition does not affect the receive alarm indication signal (RAI). When 1, an LOF condition will cause the transmit E3 A bit to be set to one if transmit automatic RAI is enabled.

Bit 6: Receive Alarm Indication on LOS Disable (RAILD) – When 0, an LOS condition will cause the transmit E3 A bit to be set to one if transmit automatic RAI is enabled. When 1, an LOS condition does not affect the RAI signal.

Bit 5: Receive Alarm Indication on OOF Disable (RAIOD) – When 0, an OOF condition will cause the transmit E3 A bit to be set to one if transmit automatic RAI is enabled. When 1, an OOF condition does not affect the RAI signal.

Bit 4: Receive Alarm Indication on AIS Disable (RAIAD) – When 0, an AIS condition will cause the transmit E3 A bit to be set to one if transmit automatic RAI is enabled. When 1, an AIS condition does not affect the RAI signal.

Bit 3: Receive Overhead Masking Disable (ROMD) – When 0, the E3 overhead positions in the outgoing E3 payload will be marked as overhead by RDENn. When 1, the E3 overhead positions in the outgoing E3 payload will be marked as data by RDENn.

Bits 2 to 1: LOF Integration Period (LIP[1:0]) – These two bits determine the OOF integration period for declaring LOF.

- 00 = OOF is integrated for 3 ms before declaring LOF
- 01 = OOF is integrated for 2 ms before declaring LOF.
- 10 = OOF is integrated for 1 ms before declaring LOF
- 11 = LOF is declared at the same time as OOF

Bit 0: Force Framer Resynchronization (FRSYNC) – A 0 to 1 transition forces an OOF condition at the FAS check. This bit must be cleared and set to one again to force another resynchronization

Register Name: **E3G751.RSR1**
 Register Description: **E3 G.751 Receive Status Register #1**
 Register Address: **(1,3,5,7)24h**

Bit #	15	14	13	12	11	10	9	8
Name	Reserved	Reserved	--	Reserved	Reserved	Reserved	Reserved	RUA1
Bit #	7	6	5	4	3	2	1	0
Name	RAB	RNB	--	LOF	RDI	AIS	OOF	LOS

Bit 8: Receive Unframed All 1's (RUA1) – When 0, the receive frame processor is not in a receive unframed all 1's (RUA1) condition. When 1, the receive frame processor is in an RUA1 condition.

Bit 7: Receive A Bit (RAB) – This bit is the integrated A bit extracted from the E3 frame.

Bit 6: Receive N Bit (RNB) – This bit is the integrated N bit extracted from the E3 frame.

Bit 4: Loss Of Frame (LOF) – When 0, the receive frame processor is not in a loss of frame (LOF) condition. When 1, the receive frame processor is in an LOF condition.

Bit 3: Remote Alarm Indication (RDI) – This bit indicates the current state of the remote alarm indication (RDI).

Bit 2: Alarm Indication Signal (AIS) – When 0, the receive frame processor is not in an alarm indication signal (AIS) condition. When 1, the receive frame processor is in an AIS condition.

Bit 1: Out Of Frame (OOF) – When 0, the receive frame processor is not in an out of frame (OOF) condition. When 1, the receive frame processor is in an OOF condition.

Bit 0: Loss Of Signal (LOS) – When 0, the receive loss of signal (LOS) input (RLOS) is low. When 1, RLOS is high.

Register Name: **E3G751.RSR2**
 Register Description: **E3 G.751 Receive Status Register #2**
 Register Address: **(1,3,5,7)26h**

Bit #	15	14	13	12	11	10	9	8
Name	--	--	--	--	--	--	--	--
Bit #	7	6	5	4	3	2	1	0
Name	--	--	--	--	Reserved	Reserved	Reserved	FEC

Bit 0: Framing Error Count (FEC) – When 0, the framing error count is zero. When 1, the framing error count is one or more.

Register Name: **E3G751.RSRL1**
 Register Description: **E3 G.751 Receive Status Register Latched #1**
 Register Address: **(1,3,5,7)28h**

Bit #	15	14	13	12	11	10	9	8
Name	<u>Reserved</u>	<u>Reserved</u>	<u>Reserved</u>	<u>Reserved</u>	<u>Reserved</u>	<u>Reserved</u>	<u>Reserved</u>	<u>RUA1L</u>
Bit #	7	6	5	4	3	2	1	0
Name	<u>ACL</u>	<u>NCL</u>	<u>COFAL</u>	<u>LOFL</u>	<u>RDIL</u>	<u>AISL</u>	<u>OOFL</u>	<u>LOSL</u>

Bit 8: Receive Unframed All 1's Change Latched (RUA1L) – This bit is set when the RUA1 bit changes state.

Bit 7: A Bit Change Latched (ACL) – This bit is set when the RAB bit changes state.

Bit 6: N Bit Change Latched (NCL) – This bit is set when the RNB bit changes state.

Bit 5: Change Of Frame Alignment Latched (COFAL) – This bit is set when the data path frame counters are updated with a new frame alignment that is different from the previous frame alignment.

Bit 4: Loss Of Frame Change Latched (LOFL) – This bit is set when the LOF bit changes state.

Bit 3: Remote Alarm Indication Change Latched (RDIL) – This bit is set when the RDI bit changes state.

Bit 2: Alarm Indication Signal Change Latched (AISL) – This bit is set when the AIS bit changes state.

Bit 1: Out Of Frame Change Latched (OOFL) – This bit is set when the OOF bit changes state.

Bit 0: Loss Of Signal Change Latched (LOSL) – This bit is set when the LOS bit changes state.

Register Name: **E3G751.RSRL2**
 Register Description: **E3 G.751 Receive Status Register Latched #2**
 Register Address: **(1,3,5,7)2Ah**

Bit #	15	14	13	12	11	10	9	8
Name	--	--	--	--	<u>Reserved</u>	<u>Reserved</u>	<u>Reserved</u>	<u>FEL</u>
Bit #	7	6	5	4	3	2	1	0
Name	--	--	--	--	<u>Reserved</u>	<u>Reserved</u>	<u>Reserved</u>	<u>FECL</u>

Bit 8: Framing Error Latched (FEL) – This bit is set when a framing error is detected.

Bit 0: Framing Error Count Latched (FECL) – This bit is set when the FEC bit transitions from zero to one.

Register Name: **E3G751.RSRIE1**
 Register Description: **E3 G.751 Receive Status Register Interrupt Enable #1**
 Register Address: **(1,3,5,7)2Ch**

Bit #	15	14	13	12	11	10	9	8
Name	Reserved	Reserved	Reserved	Reserved	Reserved	Reserved	Reserved	RUA1IE
Default	0	0	0	0	0	0	0	0

Bit #	7	6	5	4	3	2	1	0
Name	ACIE	NCIE	COFAIE	LOFIE	RDIIE	AISIE	OOFIE	LOSIE
Default	0	0	0	0	0	0	0	0

Bit 8: Receive Unframed All 1's Interrupt Enable (RUA1IE) – This bit enables an interrupt if the RUA1L bit and the bit in [GL.ISRIE.PSRIE\[4:1\]](#) that corresponds to this port are set.

0 = interrupt disabled
 1 = interrupt enabled

Bit 7: A Bit Change Interrupt Enable (ACIE) – This bit enables an interrupt if the ACL bit and the bit in [GL.ISRIE.PSRIE\[4:1\]](#) that corresponds to this port are set.

0 = interrupt disabled
 1 = interrupt enabled

Bit 6: N Bit Change Interrupt Enable (NCIE) – This bit enables an interrupt if the NCL bit and the bit in [GL.ISRIE.PSRIE\[4:1\]](#) that corresponds to this port are set.

0 = interrupt disabled
 1 = interrupt enabled

Bit 5: Change Of Frame Alignment Interrupt Enable (COFAIE) – This bit enables an interrupt if the COFAL bit and the bit in [GL.ISRIE.PSRIE\[4:1\]](#) that corresponds to this port are set.

0 = interrupt disabled
 1 = interrupt enabled

Bit 4: Loss Of Frame Interrupt Enable (LOFIE) – This bit enables an interrupt if the LOFL bit and the bit in [GL.ISRIE.PSRIE\[4:1\]](#) that corresponds to this port are set.

0 = interrupt disabled
 1 = interrupt enabled

Bit 3: Remote Alarm Indication Interrupt Enable (RDIIE) – This bit enables an interrupt if the RDIL bit and the bit in [GL.ISRIE.PSRIE\[4:1\]](#) that corresponds to this port are set.

0 = interrupt disabled
 1 = interrupt enabled

Bit 2: Alarm Indication Signal Interrupt Enable (AISIE) – This bit enables an interrupt if the AISL bit and the bit in [GL.ISRIE.PSRIE\[4:1\]](#) that corresponds to this port are set.

0 = interrupt disabled
 1 = interrupt enabled

Bit 1: Out Of Frame Interrupt Enable (OOFIE) – This bit enables an interrupt if the OOFL bit and the bit in [GL.ISRIE.PSRIE\[4:1\]](#) that corresponds to this port are set.

0 = interrupt disabled
 1 = interrupt enabled

Bit 0: Loss Of Signal Interrupt Enable (LOSIE) – This bit enables an interrupt if the LOSL bit and the bit in [GL.ISRIE.PSRIE\[4:1\]](#) that corresponds to this port are set.

0 = interrupt disabled
 1 = interrupt enabled

Register Name: **E3G751.RSRIE2**
 Register Description: **E3 G.751 Receive Status Register Interrupt Enable #2**
 Register Address: **(1,3,5,7)2Eh**

Bit #	15	14	13	12	11	10	9	8
Name	--	--	--	--	Reserved	Reserved	Reserved	FEIE
Default	0	0	0	0	0	0	0	0

Bit #	7	6	5	4	3	2	1	0
Name	--	--	--	--	Reserved	Reserved	Reserved	FECIE
Default	0	0	0	0	0	0	0	0

Bit 8: Framing Error Interrupt Enable (FEIE) – This bit enables an interrupt if the FEL bit is set and the bit in [GL.ISRIE](#).PSRIE[4:1] that corresponds to this port is set.

- 0 = interrupt disabled
- 1 = interrupt enabled

Bit 0: Framing Error Count Interrupt Enable (FECIE) – This bit enables an interrupt if the FECL bit is set and the bit in [GL.ISRIE](#).PSRIE[4:1] that corresponds to this port is set.

- 0 = interrupt disabled
- 1 = interrupt enabled

Register Name: **E3G751.RFECR**
 Register Description: **E3 G.751 Receive Framing Error Count Register**
 Register Address: **(1,3,5,7)34h**

Bit #	15	14	13	12	11	10	9	8
Name	<u>FE15</u>	<u>FE14</u>	<u>FE13</u>	<u>FE12</u>	<u>FE11</u>	<u>FE10</u>	<u>FE9</u>	<u>FE8</u>
Default	0	0	0	0	0	0	0	0

Bit #	7	6	5	4	3	2	1	0
Name	<u>FE7</u>	<u>FE6</u>	<u>FE5</u>	<u>FE4</u>	<u>FE3</u>	<u>FE2</u>	<u>FE1</u>	<u>FE0</u>
Default	0	0	0	0	0	0	0	0

Bits 15 to 0: Framing Error Count (FE[15:0]) – These sixteen bits indicate the number of framing error events on the incoming E3 data stream. This register is updated via the PMU signal (see Section [10.4.5](#)).

12.9.5 Transmit G.832 E3 Register Map

The transmit G.832 E3 utilizes four registers.

Table 12-27. Transmit G.832 E3 Framer Register Map

Address	Register	Register Description
(1,3,5,7)18h	E3G832.TCR	E3 G.832 Transmit Control Register
(1,3,5,7)1Ah	E3G832.TEIR	E3 G.832 Transmit Error Insertion Register
(1,3,5,7)1Ch	E3G832.TMABR	E3 G.832 Transmit MA Byte Register
(1,3,5,7)1Eh	E3G832.TNGBR	E3 G.832 Transmit NR and GC Byte Register

12.9.5.1 Register Bit Descriptions

Register Name: **E3G832.TCR**
 Register Description: **E3 G.832 Transmit Control Register**
 Register Address: **(1,3,5,7)18h**

Bit #	15	14	13	12	11	10	9	8
Name	Reserved	--	--	Reserved	Reserved	TGCC	TNRC1	TNRC0
Default	0	0	0	0	0	0	0	0

Bit #	7	6	5	4	3	2	1	0
Name	--	--	TFEBE	AFEBED	TRDI	ARDID	TFGC	TAIS
Default	0	0	0	0	0	0	0	0

Bit 10: Transmit GC Byte Control (TGCC) – When 0, the GC byte is inserted from the transmit HDLC controller . When 1, the GC byte is inserted from the GC byte register.

Note: If bit TGCC is 0 and TNRC[1:0] is 01, both the GC byte and NR byte will carry the same transmit HDLC controller (eight bits per frame period), however, the GC byte and NR byte in the same frame may or may not be equal.

Bits 9 to 8: Transmit NR Byte Control (TNRC[1:0]) – These two bits control the source of the NR byte.

- 00 = all ones.
- 01 = transmit from the HDLC controller.
- 10 = transmit from the FEAC controller.
- 11 = NR byte register.

Note: If TNRC[1:0] is 01 and TGCC is 0, both the NR byte and GC byte will carry the same transmit HDLC controller (eight bits per frame period), however, the NR byte and GC byte in the same frame may or may not be equal.

Bit 5: Transmit REI Error (TFEBE) – When automatic REI generation is defeated (AFEBED = 1), this bit is inserted into the second bit of the MA byte.

Bit 4: Automatic REI Defeat (AFEBED) – When 0, the REI is automatically generated based upon the transmit remote error indication (TREI) signal. When 1, the REI is inserted from the register bit TFEBE.

Bit 3: Transmit RDI Alarm (TRDI) – When automatic RDI generation is defeated (ARDID = 1), this bit is inserted into the first bit of the MA byte.

Bit 2: Automatic RDI Defeat (ARDID) – When 0, the RDI is automatically generated based upon the received E3 alarms. When 1, the RDI is inserted from the register bit TRDI.

Bit 1: Transmit Frame Generation Control (TFGC) – When this bit is zero, the Transmit Frame Processor frame generation is enabled. The E3 overhead positions in the incoming E3 payload will be overwritten with the internally generated DS3 overhead. When this bit is one, the Transmit Frame Processor frame generation is disabled. The E3 overhead positions in the incoming E3 payload will be passed through to error insertion. Note: The E3 overhead periods can still be overwritten by overhead insertion.

Bit 0: Transmit Alarm Indication Signal (TAIS) – When 0, the normal signal is transmitted. When 1, the E3 output data stream is forced to all ones (AIS).

Register Name: **E3G832.TEIR**
 Register Description: **E3 G.832 Transmit Error Insertion Register**
 Register Address: **(1,3,5,7)1Ah**

Bit #	15	14	13	12	11	10	9	8
Name	--	--	--	--	Reserved	Reserved	CFBEIE	FBEI
Default	0	0	0	0	0	0	0	0

Bit #	7	6	5	4	3	2	1	0
Name	PBEE	CPEIE	PEI	FEIC1	FEIC0	FEI	TSEI	MEIMS
Default	0	0	0	0	0	0	0	0

Bit 9: Continuous Remote Error Indication Error Insertion Enable (CFBEIE) – When 0, single remote error indication (REI) error insertion is enabled. When 1, continuous REI error insertion is enabled, and REI errors will be transmitted continuously if FEBI is high.

Bit 8: Remote Error Indication Error Insertion Enable (FBEI) – When 0, REI error insertion is disabled. When 1, REI error insertion is enabled.

Bit 7: Parity Block Error Enable (PBEE) – When 0, a parity error is generated by inverting a single bit in the EM byte. When 1, a parity error is generated by inverting all eight bits in the EM byte.

Bit 6: Continuous Parity Error Insertion Enable (CPEIE) – When 0, single parity (BIP-8) error insertion is enabled. When 1, continuous parity error insertion is enabled, and parity errors will be transmitted continuously if PEI is high.

Bit 5: Parity Error Insertion Enable (PEI) – When 0, parity error insertion is disabled. When 1, parity error insertion is enabled.

Bits 4 to 3: Framing Error Control (FEIC[1:0]) – These two bits control the framing error event to be inserted.

- 00 = single bit error in one frame.
- 01 = word error in one frame.
- 10 = single bit error in four consecutive frames.
- 11 = word error in four consecutive frames.

Bit 2: Framing Error Insertion Enable (FEI) – When 0, framing error insertion is disabled. When 1, framing error insertion is enabled.

Bit 1: Transmit Single Error Insert (TSEI) – This bit causes an error of the enabled type(s) to be inserted in the transmit data stream if manual error insertion is disabled (MEIMS = 0). A 0 to 1 transition causes a single error to be inserted. For a second error to be inserted, this bit must be set to 0, and back to 1. Note: If MEIMS is low, and this bit transitions more than once between error insertion opportunities, only one error will be inserted.

Bit 0: Manual Error Insert Mode Select (MEIMS) – When 0, error insertion is initiated by the TSEI register bit. When 1, error insertion is initiated by the transmit manual error insertion signal (TMEI). Note: If TMEI or TSEI is one, changing the state of this bit may cause an error to be inserted.

Register Name: **E3G832.TMABR**
 Register Description: **E3 G.832 Transmit MA Byte Register**
 Register Address: **(1,3,5,7)1Ch**

Bit #	15	14	13	12	11	10	9	8
Name	--	--	--	--	--	--	--	--
Default	0	0	0	0	0	0	0	0

Bit #	7	6	5	4	3	2	1	0
Name	TPT2	TPT1	TPT0	TTIGD	TTI3	TTI2	TTI1	TTI0
Default	0	0	0	0	0	0	0	0

Bits 7 to 5: Transmit Payload Type (TPT[2:0]) – These bits determines the value transmitted in the payload type (third, fourth, and fifth bits in the MA byte).

Bit 4: Transmit Timing Source Indicator Bit Generation Disable (TTIGD) – When 0, the last three bits of the MA byte (MA[6:8]) are generated from the four timing source indicator bits TTI[3:0]. When 1, TTI[3] is ignored and TTI[2:0] are directly inserted into the last three bits of the MA byte.

Bits 3 to 0: Transmit Timing Source Indication (TTI[3:0]) – These four bits make up the timing source indicator bits.

Register Name: **E3G832.TNGBR**
 Register Description: **E3 G.832 Transmit NR and GC Byte Register**
 Register Address: **(1,3,5,7)1Eh**

Bit #	15	14	13	12	11	10	9	8
Name	TGC7	TGC6	TGC5	TGC4	TGC3	TGC2	TGC1	TGC0
Default	0	0	0	0	0	0	0	0

Bit #	7	6	5	4	3	2	1	0
Name	TNR7	TNR6	TNR5	TNR4	TNR3	TNR2	TNR1	TNR0
Default	0	0	0	0	0	0	0	0

Bits 15 to 8: Transmit GC Byte (TGC[7:0]) – These eight bits are the GC byte to be inserted into the E3 frame.

Bits 7 to 0: Transmit NR Byte (TNR[7:0]) – These eight bits are the NR byte to be inserted into the E3 frame.

12.9.6 Receive G.832 E3 Register Map

The receive G.832 E3 utilizes thirteen registers.

Table 12-28. Receive G.832 E3 Framer Register Map

Address	Register	Register Description
(1,3,5,7)20h	E3G832.RCR	E3 G.832 Receive Control Register
(1,3,5,7)22h	E3G832.RMACR	E3 G.832 Receive MA Byte Control Register
(1,3,5,7)24h	E3G832.RSR1	E3 G.832 Receive Status Register #1
(1,3,5,7)26h	E3G832.RSR2	E3 G.832 Receive Status Register #2
(1,3,5,7)28h	E3G832.RSRL1	E3 G.832 Receive Status Register Latched #1
(1,3,5,7)2Ah	E3G832.RSRL2	E3 G.832 Receive Status Register Latched #2
(1,3,5,7)2Ch	E3G832.RSRIE1	E3 G.832 Receive Status Register Interrupt Enable #1
(1,3,5,7)2Eh	E3G832.RSRIE2	E3 G.832 Receive Status Register Interrupt Enable #2
(1,3,5,7)30h	E3G832.RMABR	E3 G.832 Receive MA Byte Register
(1,3,5,7)32h	E3G832.RNGBR	E3 G.832 Receive NR and GC Byte Register
(1,3,5,7)34h	E3G832.RFECR	E3 G.832 Receive Framing Error Count Register
(1,3,5,7)36h	E3G832.RPECR	E3 G.832 Receive Parity Error Count Register
(1,3,5,7)38h	E3G832.RFBER	E3 G.832 Receive Remote Error Indication Count Register
(1,3,5,7)3Ah	--	Reserved
(1,3,5,7)3Ch	--	Unused
(1,3,5,7)3Eh	--	Unused

12.9.6.1 Register Bit Descriptions

Register Name: **E3G832.RCR**
 Register Description: **E3 G.832 Receive Control Register**
 Register Address: **(1,3,5,7)20h**

Bit #	15	14	13	12	11	10	9	8
Name	Reserved	PEC	DLS	MDAISI	AAISD	ECC	FECC1	FECC0
Default	0	0	0	0	0	0	0	0

Bit #	7	6	5	4	3	2	1	0
Name	RDILE	RDILD	RDIOD	RDIAD	ROMD	LIP1	LIP0	FRSYNC
Default	0	0	0	0	0	0	0	0

Bit 14: Parity Error Count (PEC) – When 0, BIP-8 block errors (EM byte) are detected (no more than one per frame). When 1, BIP-8-bit errors are detected (up to 8 per frame).

Bit 13: Receive HDLC Data Link Source (DLS) – When 0, the receive HDLC data link will be sourced from the GC byte. When 1, the receive HDLC data link will be sourced from the NR byte.

Bit 12: Manual Downstream AIS Insertion (MDAISI) – When 0, manual downstream AIS insertion is disabled. When 1, manual downstream AIS insertion is enabled.

Bit 11: Automatic Downstream AIS Disable (AAISD) – When 0, the presence of an LOS, OOF, or AIS condition will cause downstream AIS to be inserted. When 1, the presence of an LOS, OOF, or AIS condition will not cause downstream AIS to be inserted.

Bit 10: Error Count Control (ECC) – When 0, framing errors, parity errors, and REI errors will not be counted if an OOF or AIS condition is present. Parity errors and REI errors will also not be counted during the E3 frame in which

an OOF or AIS condition is terminated, and the next E3 frame. When 1, framing errors, parity errors, and REI errors will be counted regardless of the presence of an OOF or AIS condition.

Bits 9 to 8: Framing Error Count Control (FECC[1:0]) – These two bits control the type of framing error events that are counted.

- 00 = count OOF occurrences (counted regardless of the setting of the ECC bit)..
- 01 = count each bit error in FA1 and FA2 (up to 16 per frame).
- 10 = count frame alignment word (FA1 and FA2) errors (up to one per frame).
- 11 = count FA1 byte errors and FA2 byte errors (up to 2 per frame).

Bit 7: Receive Defect Indication on LOF Enable (RDILE) – When 0, an LOF condition does not affect the receive defect indication signal (RDI). When 1, an LOF condition will cause the transmit E3 RDI bit to be set to one if transmit automatic RDI is enabled.

Bit 6: Receive Defect Indication on LOS Disable (RDILD) – When 0, an LOS condition will cause the transmit E3 RDI bit to be set to one if transmit automatic RDI is enabled. When 1, an LOS condition does not affect the RDI signal.

Bit 5: Receive Defect Indication on OOF Disable (RDIOD) – When 0, an OOF condition will cause the transmit E3 RDI bit to be set to one if transmit automatic RDI is enabled. When 1, an OOF condition does not affect the RDI signal.

Bit 4: Receive Defect Indication on AIS Disable (RDIAD) – When 0, an AIS condition will cause the transmit E3 RDI bit to be set to one if transmit automatic RDI is enabled. When 1, an AIS condition does not affect the RDI signal.

Bit 3: Receive Overhead Masking Disable (ROMD) – When 0, the E3 overhead positions in the outgoing E3 payload will be marked as overhead by RDENn. When 1, the E3 overhead positions in the outgoing E3 payload will be marked as data by RDENn.

Bits 2 to 1: LOF Integration Period (LIP[1:0]) – These two bits determine the OOF integration period for declaring LOF.

- 00 = OOF is integrated for 3 ms before declaring LOF.
- 01 = OOF is integrated for 2 ms before declaring LOF.
- 10 = OOF is integrated for 1 ms before declaring LOF.
- 11 = LOF is declared at the same time as OOF.

Bit 0: Force Framer Resynchronization (FRSYNC) – A 0 to 1 transition forces an OOF condition at the next framing word check. This bit must be cleared and set to one again to force another resynchronization.

Register Name: **E3G832.RMACR**
 Register Description: **E3 G.832 Receive MA Byte Control Register**
 Register Address: **(1,3,5,7)22h**

Bit #	15	14	13	12	11	10	9	8
Name	--	--	--	--	--	--	--	--
Default	0	0	0	0	0	0	0	0

Bit #	7	6	5	4	3	2	1	0
Name	--	--	--	--	EPT2	EPT1	EPT0	TIED
Default	0	0	0	0	0	0	0	0

Bits 3 to 1: Expected Payload Type (EPT[2:0]) – These three bits contain the expected value of the payload type.

Bit 0: Timing Source Indicator Bit Extraction Disable (TIED) – When 0, the four timing source indications bits are extracted from the last three bits of the MA byte (MA[6:8]), and stored in a register. When 1, timing source indicator bit extraction is disabled, and the last three bits of the MA byte are integrated and stored in a register.

Register Name: **E3G832.RSR1**
 Register Description: **E3 G.832 Receive Status Register #1**
 Register Address: **(1,3,5,7)24h**

Bit #	15	14	13	12	11	10	9	8
Name	Reserved	--	--	RPTU	RPTM	Reserved	Reserved	RUA1
Bit #	7	6	5	4	3	2	1	0
Name	Reserved	Reserved	--	LOF	RAI	AIS	OOF	LOS

Bit 12: Receive Payload Type Unstable (RPTU) – When 0, the receive payload type is stable. When 1, the receive payload type is unstable.

Bit 11: Receive Payload Type Mismatch (RPTM) – When 0, the receive payload type and expected payload type match. When 1, the receive payload type and expected payload type do not match.

Bit 8: Receive Unframed All 1's (RUA1) – When 0, the receive frame processor is not in a receive unframed all 1's (RUA1) condition. When 1, the receive frame processor is in an RUA1 condition.

Bit 4: Loss Of Frame (LOF) – When 0, the receive frame processor is not in a loss of frame (LOF) condition. When 1, the receive frame processor is in an LOF condition.

Bit 3: Remote Defect Indication (RDI) – This bit indicates the current state of the remote defect indication (RDI).

Bit 2: Alarm Indication Signal (AIS) – When 0, the receive frame processor is not in an alarm indication signal (AIS) condition. When 1, the receive frame processor is in an AIS condition.

Bit 1: Out Of Frame (OOF) – When 0, the receive frame processor is not in an out of frame (OOF) condition. When 1, the receive frame processor is in an OOF condition.

Bit 0: Loss Of Signal (LOS) – When 0, the receive loss of signal (LOS) input (RLOS) is low. When 1, RLOS is high.

Register Name: **E3G832.RSR2**
 Register Description: **E3 G.832 Receive Status Register #2**
 Register Address: **(1,3,5,7)26h**

Bit #	15	14	13	12	11	10	9	8
Name	--	--	--	--	--	--	--	--
Bit #	7	6	5	4	3	2	1	0
Name	--	--	--	--	Reserved	FBEC	PEC	FEC

Bit 2: Remote Error Indication Count (FBEC) – When 0, the remote error indication count is zero. When 1, the remote error indication count is one or more.

Bit 1: Parity Error Count (PEC) – When 0, the parity error count is zero. When 1, the parity error count is one or more.

Bit 0: Framing Error Count (FEC) – When 0, the framing error count is zero. When 1, the framing error count is one or more.

Register Name: **E3G832.RSRL1**
 Register Description: **E3 G.832 Receive Status Register Latched #1**
 Register Address: **(1,3,5,7)28h**

Bit #	15	14	13	12	11	10	9	8
Name	<u>Reserved</u>	<u>--</u>	<u>TIL</u>	<u>RPTUL</u>	<u>RPTML</u>	<u>RPTL</u>	<u>Reserved</u>	<u>RUA1L</u>
Bit #	7	6	5	4	3	2	1	0
Name	<u>GCL</u>	<u>NRL</u>	<u>COFAL</u>	<u>LOFL</u>	<u>RDIL</u>	<u> AISL</u>	<u>OOFL</u>	<u>LOSL</u>

Bit 13: Timing Source Indication Change Latched (TIL) – This bit is set when the TI[3:0] bits change state.

Bit 12: Receive Payload Type Unstable Latched (RPTUL) – This bit is set when the RPTU bit transitions from zero to one.

Bit 11: Receive Payload Type Mismatch Latched (RPTML) – This bit is set when the RPTM bit transitions from zero to one.

Bit 10: Receive Payload Type Change Latched (RPTL) – This bit is set when the RPT[2:0] bits change state.

Bit 8: Receive Unframed All 1's Change Latched (RUA1L) – This bit is set when the RUA1 bit changes state.

Bit 7: GC Byte Change Latched (GCL) – This bit is set when the RGC byte changes state.

Bit 6: NR Byte Change Latched (NRL) – This bit is set when the RNR byte changes state.

Bit 5: Change Of Frame Alignment Latched (COFAL) – This bit is set when the data path frame counters are updated with a new frame alignment that is different from the previous frame alignment.

Bit 4: Loss Of Frame Change Latched (LOFL) – This bit is set when the LOF bit changes state.

Bit 3: Remote Defect Indication Change Latched (RDIL) – This bit is set when the RDI bit changes state.

Bit 2: Alarm Indication Signal Change Latched (AISL) – This bit is set when the AIS bit changes state.

Bit 1: Out Of Frame Change Latched (OOFL) – This bit is set when the OOF bit changes state.

Bit 0: Loss Of Signal Change Latched (LOSL) – This bit is set when the LOS bit changes state.

Register Name: **E3G832.RSRL2**
 Register Description: **E3 G.832 Receive Status Register Latched #2**
 Register Address: **(1,3,5,7)2Ah**

Bit #	15	14	13	12	11	10	9	8
Name	<u>--</u>	<u>--</u>	<u>--</u>	<u>--</u>	<u>Reserved</u>	<u>FBEL</u>	<u>PEL</u>	<u>FEL</u>
Bit #	7	6	5	4	3	2	1	0
Name	<u>--</u>	<u>--</u>	<u>--</u>	<u>--</u>	<u>Reserved</u>	<u>FBECL</u>	<u>PECL</u>	<u>FECL</u>

Bit 10: Remote Error Indication Latched (FBEL) – This bit is set when a remote error indication is detected.

Bit 9: Parity Error Latched (PEL) – This bit is set when a BIP-8 parity error is detected.

Bit 8: Framing Error Latched (FEL) – This bit is set when a framing error is detected.

Bit 2: Remote Error Indication Count Latched (FBECL) – This bit is set when the FBEC bit transitions from zero to one.

Bit 1: Parity Error Count Latched (PECL) – This bit is set when the PEC bit transitions from zero to one.

Bit 0: Framing Error Count Latched (FECL) – This bit is set when the FEC bit transitions from zero to one.

Register Name: **E3G832.RSRIE1**
 Register Description: **E3 G.832 Receive Status Register Interrupt Enable #1**
 Register Address: **(1,3,5,7)2Ch**

Bit #	15	14	13	12	11	10	9	8
Name	Reserved	--	TIIE	RPTUIE	RPTMIE	RPTIE	Reserved	RUA1IE
Default	0	0	0	0	0	0	0	0

Bit #	7	6	5	4	3	2	1	0
Name	GCIE	NRIE	COFAIE	LOFIE	RAIIE	AISIE	OOFIE	LOSIE
Default	0	0	0	0	0	0	0	0

Bit 13: Timing Indication Interrupt Enable (TIIE) – This bit enables an interrupt if the TIL bit is set and the bit in [GL.ISRIE.PSRIE\[4:1\]](#) that corresponds to this port is set.

0 = interrupt disabled
 1 = interrupt enabled

Bit 12: Receive Payload Type Unstable Interrupt Enable (RPTUIE) – This bit enables an interrupt if the RPTUL bit is set and the bit in [GL.ISRIE.PSRIE\[4:1\]](#) that corresponds to this port is set.

0 = interrupt disabled
 1 = interrupt enabled

Bit 11: Receive Payload Type Mismatch Interrupt Enable (RPTMIE) – This bit enables an interrupt if the RPTML bit is set and the bit in [GL.ISRIE.PSRIE\[4:1\]](#) that corresponds to this port is set.

0 = interrupt disabled
 1 = interrupt enabled

Bit 10: Receive Payload Type Interrupt Enable (RPTIE) – This bit enables an interrupt if the RPTL bit is set and the bit in [GL.ISRIE.PSRIE\[4:1\]](#) that corresponds to this port is set.

0 = interrupt disabled
 1 = interrupt enabled

Bit 8: Receive Unframed All 1's Interrupt Enable (RUA1IE) – This bit enables an interrupt if the RUA1L bit is set and the bit in [GL.ISRIE.PSRIE\[4:1\]](#) that corresponds to this port is set.

0 = interrupt disabled
 1 = interrupt enabled

Bit 7: GC Byte Interrupt Enable (GCIE) – This bit enables an interrupt if the GCL bit is set and the bit in [GL.ISRIE.PSRIE\[4:1\]](#) that corresponds to this port is set.

0 = interrupt disabled
 1 = interrupt enabled

Bit 6: NR Byte Interrupt Enable (NRIE) – This bit enables an interrupt if the NRL bit is set and the bit in [GL.ISRIE.PSRIE\[4:1\]](#) that corresponds to this port is set.

0 = interrupt disabled
 1 = interrupt enabled

Bit 5: Change Of Frame Alignment Interrupt Enable (COFAIE) – This bit enables an interrupt if the COFAL bit is set and the bit in [GL.ISRIE.PSRIE\[4:1\]](#) that corresponds to this port is set.

0 = interrupt disabled
 1 = interrupt enabled

Bit 4: Loss Of Frame Interrupt Enable (LOFIE) – This bit enables an interrupt if the LOFL bit is set and the bit in [GL.ISRIE.PSRIE\[4:1\]](#) that corresponds to this port is set.

0 = interrupt disabled
 1 = interrupt enabled

Bit 3: Remote Defect Indication Interrupt Enable (RDIIE) – This bit enables an interrupt if the RDIL bit is set and the bit in [GL.ISRIE](#).PSRIE[4:1] that corresponds to this port is set.

0 = interrupt disabled

1 = interrupt enabled

Bit 2: Alarm Indication Signal Interrupt Enable (AISIE) – This bit enables an interrupt if the AISL bit is set and the bit in [GL.ISRIE](#).PSRIE[4:1] that corresponds to this port is set.

0 = interrupt disabled

1 = interrupt enabled

Bit 1: Out Of Frame Interrupt Enable (OOFIE) – This bit enables an interrupt if the OOFL bit is set and the bit in [GL.ISRIE](#).PSRIE[4:1] that corresponds to this port is set.

0 = interrupt disabled

1 = interrupt enabled

Bit 0: Loss Of Signal Interrupt Enable (LOSIE) – This bit enables an interrupt if the LOSL bit is set and the bit in [GL.ISRIE](#).PSRIE[4:1] that corresponds to this port is set.

0 = interrupt disabled

1 = interrupt enabled

Register Name: **E3G832.RSRIE2**
 Register Description: **E3 G.832 Receive Status Register Interrupt Enable #2**
 Register Address: **(1,3,5,7)2Eh**

Bit #	15	14	13	12	11	10	9	8
Name	--	--	--	--	Reserved	FBEIE	PEIE	FEIE
Default	0	0	0	0	0	0	0	0

Bit #	7	6	5	4	3	2	1	0
Name	--	--	--	--	Reserved	FBEICIE	PEICIE	FECIE
Default	0	0	0	0	0	0	0	0

Bit 10: Remote Error Indication Interrupt Enable (FBEIE) – This bit enables an interrupt if the FBEL bit is set and the bit in [GL.ISRIE](#).PSRIE[4:1] that corresponds to this port is set.

0 = interrupt disabled
 1 = interrupt enabled

Bit 9: Parity Error Interrupt Enable (PEIE) – This bit enables an interrupt if the PEL bit is set and the bit in [GL.ISRIE](#).PSRIE[4:1] that corresponds to this port is set.

0 = interrupt disabled
 1 = interrupt enabled

Bit 8: Framing Error Interrupt Enable (FEIE) – This bit enables an interrupt if the FEL bit is set and the bit in [GL.ISRIE](#).PSRIE[4:1] that corresponds to this port is set.

0 = interrupt disabled
 1 = interrupt enabled

Bit 2: Remote Error Indication Count Interrupt Enable (FBEICIE) – This bit enables an interrupt if the FBECL bit is set and the bit in [GL.ISRIE](#).PSRIE[4:1] that corresponds to this port is set.

0 = interrupt disabled
 1 = interrupt enabled

Bit 1: Parity Error Count Interrupt Enable (PEICIE) – This bit enables an interrupt if the PECL bit is set and the bit in [GL.ISRIE](#).PSRIE[4:1] that corresponds to this port is set.

0 = interrupt disabled
 1 = interrupt enabled

Bit 0: Framing Error Count Interrupt Enable (FECIE) – This bit enables an interrupt if the FECL bit is set and the bit in [GL.ISRIE](#).PSRIE[4:1] that corresponds to this port is set.

0 = interrupt disabled
 1 = interrupt enabled

Register Name: **E3G832.RMABR**
 Register Description: **E3 G.832 Receive MA Byte Register**
 Register Address: **(1,3,5,7)30h**

Bit #	15	14	13	12	11	10	9	8
Name	--	--	--	--	--	--	--	--
Default	0	0	0	0	0	0	0	0

Bit #	7	6	5	4	3	2	1	0
Name	--	<u>RPT2</u>	<u>RPT1</u>	<u>RPT0</u>	<u>TI3</u>	<u>TI2</u>	<u>TI1</u>	<u>TI0</u>
Default	0	0	0	0	0	0	0	0

Bits 6 to 4: Receive Payload Type (RPT[2:0]) – These three bits are the integrated version of the payload type (MA[3:5]) from the MA byte.

Bits 3 to 0: Receive Timing Source Indication (TI[3:0]) – When timing source indicator extraction is enabled, these four bits are the integrated version of the four timing source indicator bits extracted from the last three bits of the MA byte (MA[6:8]). When timing source indicator bit extraction is disabled, TI[3] is zero, and TI[2:0] contain the integrated version of the last three bits of the MA byte.

Register Name: **E3G832.RNGBR**
 Register Description: **E3 G.832 Receive NR and GC Byte Register**
 Register Address: **(1,3,5,7)32h**

Bit #	15	14	13	12	11	10	9	8
Name	<u>RGC7</u>	<u>RGC6</u>	<u>RGC5</u>	<u>RGC4</u>	<u>RGC3</u>	<u>RGC2</u>	<u>RGC1</u>	<u>RGC0</u>
Default	0	0	0	0	0	0	0	0

Bit #	7	6	5	4	3	2	1	0
Name	<u>RNR7</u>	<u>RNR6</u>	<u>RNR5</u>	<u>RNR4</u>	<u>RNR3</u>	<u>RNR2</u>	<u>RNR1</u>	<u>RNR0</u>
Default	0	0	0	0	0	0	0	0

Bits 15 to 8: Receive GC Byte (RGC[7:0]) – These eight bits are the integrated version of the GC byte as extracted from the E3 frame.

Bits 7 to 0: Receive NR Byte (RNR[7:0]) – These eight bits are the integrated version of the NR byte as extracted from the E3 frame.

Register Name: **E3G832.RFECR**
 Register Description: **E3 G.832 Receive Framing Error Count Register**
 Register Address: **(1,3,5,7)34h**

Bit #	15	14	13	12	11	10	9	8
Name	<u>FE15</u>	<u>FE14</u>	<u>FE13</u>	<u>FE12</u>	<u>FE11</u>	<u>FE10</u>	<u>FE9</u>	<u>FE8</u>
Default	0	0	0	0	0	0	0	0

Bit #	7	6	5	4	3	2	1	0
Name	<u>FE7</u>	<u>FE6</u>	<u>FE5</u>	<u>FE4</u>	<u>FE3</u>	<u>FE2</u>	<u>FE1</u>	<u>FE0</u>
Default	0	0	0	0	0	0	0	0

Bits 15 to 0: Framing Error Count (FE[15:0]) – These sixteen bits indicate the number of framing error events on the incoming E3 data stream. This register is updated via the PMU signal (see Section [10.4.5](#)).

Register Name: **E3G832.RPECR**
 Register Description: **E3 G.832 Receive Parity Error Count Register**
 Register Address: **(1,3,5,7)36h**

Bit #	15	14	13	12	11	10	9	8
Name	<u>PE15</u>	<u>PE14</u>	<u>PE13</u>	<u>PE12</u>	<u>PE11</u>	<u>PE10</u>	<u>PE9</u>	<u>PE8</u>
Default	0	0	0	0	0	0	0	0

Bit #	7	6	5	4	3	2	1	0
Name	<u>PE7</u>	<u>PE6</u>	<u>PE5</u>	<u>PE4</u>	<u>PE3</u>	<u>PE2</u>	<u>PE1</u>	<u>PE0</u>
Default	0	0	0	0	0	0	0	0

Bits 15 to 0: Parity Error Count (PE[15:0]) – These sixteen bits indicate the number of parity (BIP-8) errors detected on the incoming E3 data stream. This register is updated via the PMU signal (see Section [10.4.5](#)).

Register Name: **E3G832.RFBER**
 Register Description: **E3 G.832 Receive Remote Error Indication Count Register**
 Register Address: **(1,3,5,7)38h**

Bit #	15	14	13	12	11	10	9	8
Name	<u>FBE15</u>	<u>FBE14</u>	<u>FBE13</u>	<u>FBE12</u>	<u>FBE11</u>	<u>FBE10</u>	<u>FBE9</u>	<u>FBE8</u>
Default	0	0	0	0	0	0	0	0

Bit #	7	6	5	4	3	2	1	0
Name	<u>FBE7</u>	<u>FBE6</u>	<u>FBE5</u>	<u>FBE4</u>	<u>FBE3</u>	<u>FBE2</u>	<u>FBE1</u>	<u>FBE0</u>
Default	0	0	0	0	0	0	0	0

Bits 15 to 0: Remote Error Indication Count (FBE[15:0]) – These sixteen bits indicate the number of remote error indications detected on the incoming E3 data stream. This register is updated via the PMU signal (see Section [10.4.5](#)).

12.9.7 Transmit Clear Channel

The transmit Clear Channel mode utilizes one register.

12.9.7.1 Register Map

Table 12-29. Transmit Clear Channel Register Map

Address	Register	Register Description
(1,3,5,7)18h	CC.TCR	Clear Channel Transmit Control Register
(1,3,5,7)1Ah	--	Reserved
(1,3,5,7)1Ch	--	Reserved
(1,3,5,7)1Eh	--	Reserved

12.9.7.2 Register Bit Descriptions

Register Name: **CC.TCR**
 Register Description: **Clear Channel Transmit Control Register**
 Register Address: **(1,3,5,7)18h**

Bit #	15	14	13	12	11	10	9	8
Name	Reserved	--	--	Reserved	Reserved	Reserved	Reserved	Reserved
Default	0	0	0	0	0	0	0	0

Bit #	7	6	5	4	3	2	1	0
Name	--	--	Reserved	Reserved	Reserved	Reserved	Reserved	TAIS
Default	0	0	0	0	0	0	0	0

Bit 0: Transmit Alarm Indication Signal (TAIS) – When 0, the normal signal is transmitted. When 1, the output clear channel data stream is forced to all ones (AIS). Note: This bit is logically ORed with the TAIS input signal.

12.9.8 Receive Clear Channel

The receive Clear Channel mode utilizes four registers.

12.9.8.1 Register Map

Table 12-30. Receive Clear Channel Register Map

Address	Register	Register Description
(1,3,5,7)20h	CC.RCR	Clear Channel Receive Control Register
(1,3,5,7)22h	--	Reserved
(1,3,5,7)24h	CC.RSR1	Clear Channel Receive Status Register #1
(1,3,5,7)26h	--	Reserved
(1,3,5,7)28h	CC.RSRL1	Clear Channel Receive Status Register Latched #1
(1,3,5,7)2Ah	--	Reserved
(1,3,5,7)2Ch	CC.RSRIE1	Clear Channel Receive Status Register Interrupt Enable #1
(1,3,5,7)2Eh	--	Reserved
(1,3,5,7)30h	--	Reserved
(1,3,5,7)32h	--	Reserved
(1,3,5,7)34h	--	Reserved
(1,3,5,7)36h	--	Reserved
(1,3,5,7)38h	--	Reserved
(1,3,5,7)3Ah	--	Reserved
(1,3,5,7)3Ch	--	Unused
(1,3,5,7)3Eh	--	Unused

12.9.8.2 Register Bit Descriptions

Register Name: **CC.RCR**
 Register Description: **Clear Channel Receive Control Register**
 Register Address: **(1,3,5,7)20h**

Bit #	15	14	13	12	11	10	9	8
Name	Reserved	Reserved	Reserved	MDAISI	AAISD	Reserved	Reserved	Reserved
Default	0	0	0	0	0	0	0	0

Bit #	7	6	5	4	3	2	1	0
Name	Reserved	Reserved	Reserved	Reserved	Reserved	Reserved	Reserved	Reserved
Default	0	0	0	0	0	0	0	0

Bit 12: Manual Downstream AIS Insertion (MDAISI) – When 0, manual downstream AIS insertion is disabled. When 1, manual downstream AIS insertion is enabled.

Bit 11: Automatic Downstream AIS Disable (AAISD) – When 0, the presence of an LOS condition will cause downstream AIS to be inserted. When 1, the presence of an LOS condition will not cause downstream AIS to be inserted.

Register Name: **CC.RSR1**
 Register Description: **Clear Channel Receive Status Register #1**
 Register Address: **(1,3,5,7)24h**

Bit #	15	14	13	12	11	10	9	8
Name	Reserved	Reserved	--	Reserved	Reserved	Reserved	Reserved	RUA1
Default	0	0	0	0	0	0	0	0

Bit #	7	6	5	4	3	2	1	0
Name	Reserved	Reserved	--	Reserved	Reserved	Reserved	Reserved	LOS
Default	0	0	0	0	0	0	0	0

Bit 8: Receive Unframed All 1's (RUA1) – When 0, the receive frame processor is not in a receive unframed all 1's (RUA1) condition. When 1, the receive frame processor is in an RUA1 condition.

Bit 0: Loss Of Signal (LOS) – When 0, the receive loss of signal (LOS) input (RLOS) is low. When 1, RLOS is high.

Register Name: **CC.RSRL1**
 Register Description: **Clear Channel Receive Status Register Latched #1**
 Register Address: **(1,3,5,7)28h**

Bit #	15	14	13	12	11	10	9	8
Name	Reserved	Reserved	Reserved	Reserved	Reserved	Reserved	Reserved	RUA1L
Default	0	0	0	0	0	0	0	0

Bit #	7	6	5	4	3	2	1	0
Name	Reserved	Reserved	Reserved	Reserved	Reserved	Reserved	Reserved	LOSL
Default	0	0	0	0	0	0	0	0

Bit 8: Receive Unframed All 1's Latched (RUA1L) – This bit is set when the RUA1 bit changes state.

Bit 0: Loss Of Signal Change Latched (LOSL) – This bit is set when the LOS bit changes state.

Register Name: **CC.RSRIE1**
 Register Description: **Clear Channel Receive Status Register Interrupt Enable #1**
 Register Address: **(1,3,5,7)2Ch**

Bit #	15	14	13	12	11	10	9	8
Name	Reserved	Reserved	Reserved	Reserved	Reserved	Reserved	Reserved	RUA1IE
Default	0	0	0	0	0	0	0	0

Bit #	7	6	5	4	3	2	1	0
Name	Reserved	Reserved	Reserved	Reserved	Reserved	Reserved	Reserved	LOSIE
Default	0	0	0	0	0	0	0	0

Bit 8: Receive Unframed All 1's Interrupt Enable (RUA1IE) – This bit enables an interrupt if the RUA1L bit is set.

0 = interrupt disabled

1 = interrupt enabled

Bit 0: Loss Of Signal Interrupt Enable (LOSIE) – This bit enables an interrupt if the LOSL bit is set.

0 = interrupt disabled

1 = interrupt enabled

13 JTAG INFORMATION

13.1 JTAG Description

This device supports the standard instruction codes SAMPLE/PRELOAD, BYPASS, and EXTEST. Optional public instructions included are HIGHZ, CLAMP, and IDCODE. The device contains the following items, which meet the requirements set by the IEEE 1149.1 Standard Test Access Port (TAP) and Boundary Scan Architecture:

- Test Access Port (TAP)
- TAP Controller
- Instruction Register
- Bypass Register
- Boundary Scan Register
- Device Identification Register

The Test Access Port has the necessary interface pins, namely JTCLK, JTDI, JTDO, and JTMS, and the optional JTRST input. Details on these pins can be found in Section 8. Refer to IEEE 1149.1-1990, IEEE 1149.1a-1993, and IEEE 1149.1b-1994 for details about the Boundary Scan Architecture and the Test Access Port.

Figure 13-1. JTAG Block Diagram

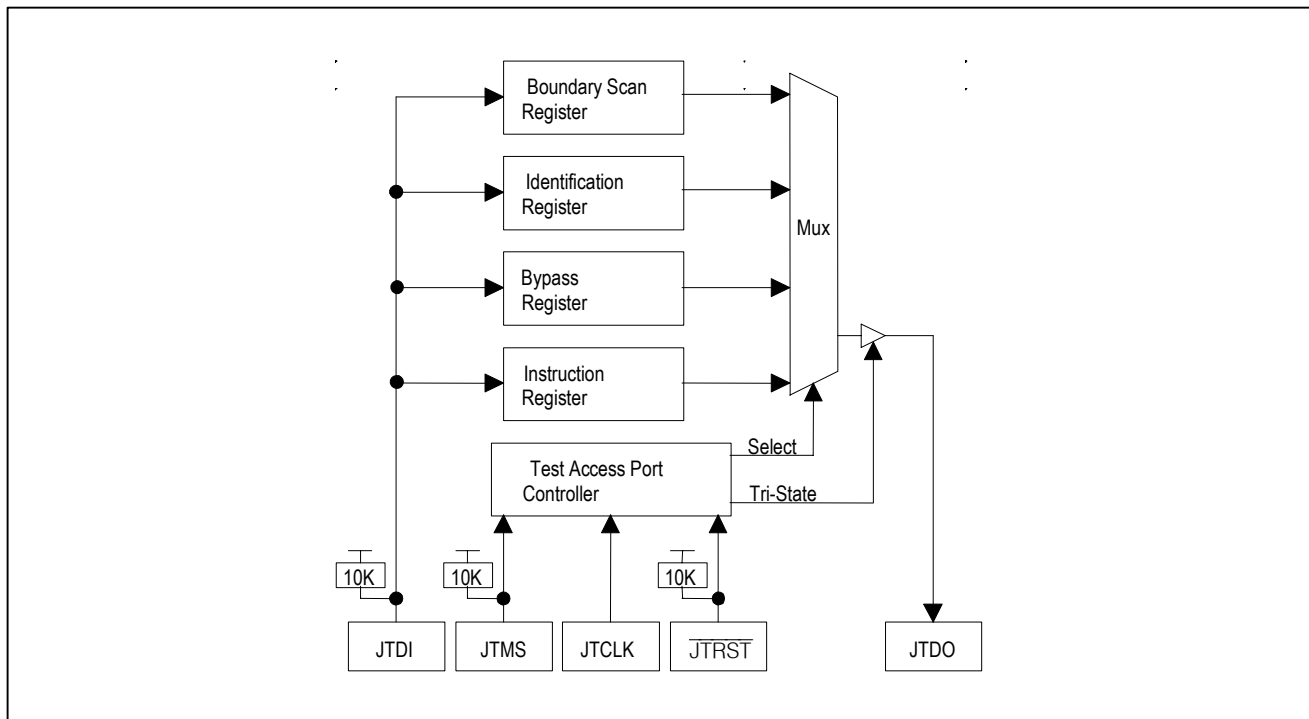

13.2 JTAG TAP Controller State Machine Description

This section covers the details on the operation of the Test Access Port (TAP) Controller State Machine. See [Figure 13-2](#) for details on each of the states described below. The TAP controller is a finite state machine that responds to the logic level at JTMS on the rising edge of JTCLK.

Figure 13-2. JTAG TAP Controller State Machine

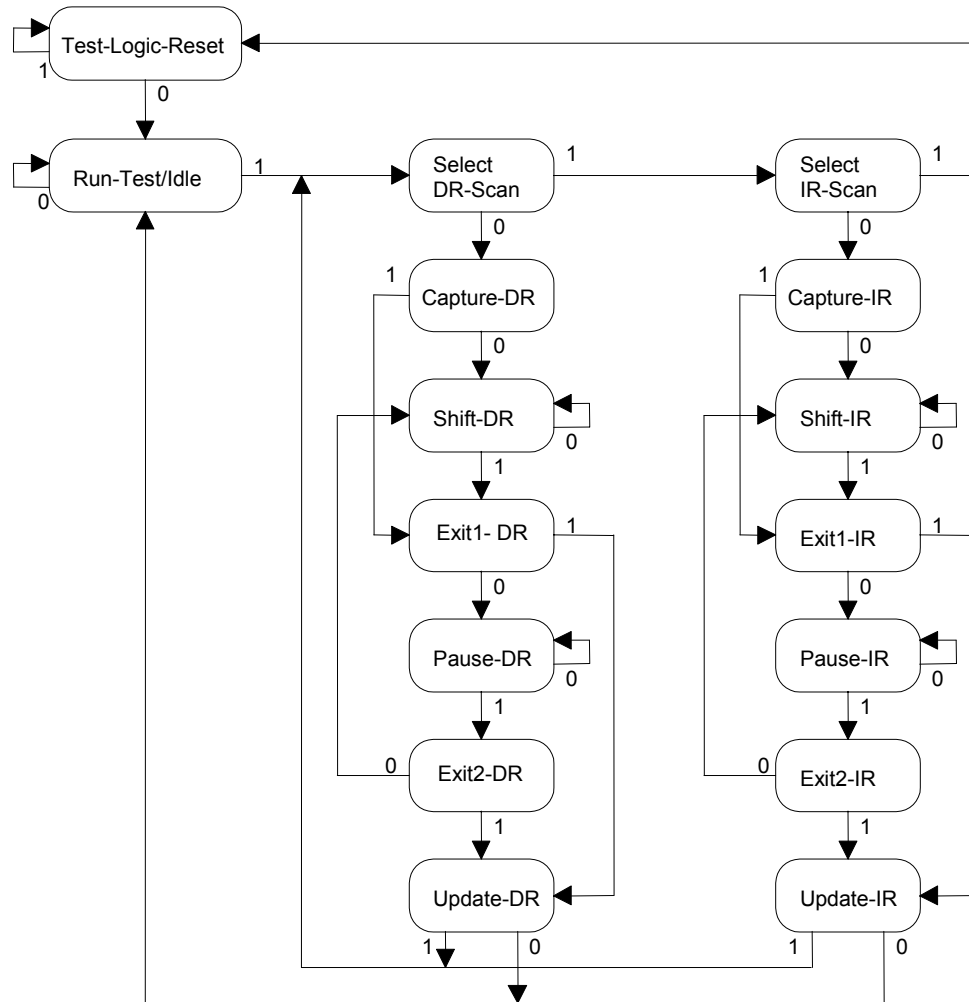

Test-Logic-Reset. When $\overline{\text{JTRST}}$ is changed from low to high, the TAP controller starts in the Test-Logic-Reset state, and the Instruction Register is loaded with the **IDCODE** instruction. All system logic and I/O pads on the device operate normally. This state can also be reached from any other state by holding JTMS high and clocking JTCLK five times.

Run-Test-Idle. Run-Test-Idle is used between scan operations or during specific tests. The Instruction Register and Test Register remain idle.

Select-DR-Scan. All test registers retain their previous state. With JTMS low, a rising edge of JTCLK moves the controller into the Capture-DR state and initiates a scan sequence. JTMS high moves the controller to the Select-IR-Scan state.

Capture-DR. Data may be parallel loaded into the Test Data register selected by the current instruction. If the instruction does not call for a parallel load or the selected register does not allow parallel loads, the Test Register remains at its current value. On the rising edge of JTCLK, the controller goes to the Shift-DR state if JTMS is low or to the Exit1-DR state if JTMS is high.

Shift-DR. The Test Data Register selected by the current instruction is connected between JTDI and JTDO and shifts data one stage towards its serial output on each rising edge of JTCLK. If a Test Register selected by the current instruction is not placed in the serial path, it maintains its previous state.

Exit1-DR. While in this state, a rising edge on JTCLK with JTMS high puts the controller in the Update-DR state that terminates the scanning process. A rising edge on JTCLK with JTMS low puts the controller in the Pause-DR state.

Pause-DR. Shifting of the Test registers is halted while in this state. All Test registers selected by the current instruction retain their previous state. The controller remains in this state while JTMS is low. A rising edge on JTCLK with JTMS high puts the controller in the Exit2-DR state.

Exit2-DR. While in this state, a rising edge on JTCLK with JTMS high puts the controller in the Update-DR state and terminate the scanning process. A rising edge on JTCLK with JTMS low puts the controller in the Shift-DR state.

Update-DR. A falling edge on JTCLK while in the Update-DR state latches the data from the shift register path of the Test registers into the data output latches. This prevents changes at the parallel output due to changes in the shift register. A rising edge on JTCLK with JTMS low, puts the controller in the Run-Test-Idle state. With JTMS high, the controller enters the Select-DR-Scan state.

Select-IR-Scan. All Test registers retain their previous state. The Instruction register remains unchanged during this state. With JTMS low, a rising edge on JTCLK moves the controller into the Capture-IR state and initiates a scan sequence for the Instruction register. JTMS high during a rising edge on JTCLK puts the controller back into the Test-Logic-Reset state.

Capture-IR. The Capture-IR state is used to load the shift register in the Instruction register with a fixed value of 001. This value is loaded on the rising edge of JTCLK. If JTMS is high on the rising edge of JTCLK, the controller enters the Exit1-IR state. If JTMS is low on the rising edge of JTCLK, the controller enters the Shift-IR state.

Shift-IR. In this state, the shift register in the Instruction register is connected between JTDI and JTDO and shifts data one stage for every rising edge of JTCLK towards the serial output. The parallel registers, as well as all Test registers, remain at their previous states. A rising edge on JTCLK with JTMS high moves the controller to the Exit1-IR state. A rising edge on JTCLK with JTMS low keeps the controller in the Shift-IR state while moving data one stage through the Instruction shift register.

Exit1-IR. A rising edge on JTCLK with JTMS low puts the controller in the Pause-IR state. If JTMS is high on the rising edge of JTCLK, the controller enters the Update-IR state and terminate the scanning process.

Pause-IR. Shifting of the Instruction register is halted temporarily. With JTMS high, a rising edge on JTCLK puts the controller in the Exit2-IR state. The controller remains in the Pause-IR state if JTMS is low during a rising edge on JTCLK.

Exit2-IR. A rising edge on JTCLK with JTMS high put the controller in the Update-IR state. The controller loops back to the Shift-IR state if JTMS is low during a rising edge of JTCLK in this state.

Update-IR. The instruction shifted into the Instruction shift register is latched into the parallel output on the falling edge of JTCLK as the controller enters this state. Once latched, this instruction becomes the current instruction. A rising edge on JTCLK with JTMS low, puts the controller in the Run-Test-Idle state. With JTMS high, the controller enters the Select-DR-Scan state.

13.3 JTAG Instruction Register and Instructions

The instruction register contains a shift register as well as a latched parallel output and is 3 bits in length. When the TAP controller enters the Shift-IR state, the instruction shift register is connected between JTDI and JTDO. While in the Shift-IR state, a rising edge on JTCLK with JTMS low shifts data one stage toward the serial output at JTDO. A rising edge on JTCLK in the Exit1-IR state or the Exit2-IR state with JTMS high moves the controller to the Update-IR state. The falling edge of that same JTCLK latches the data in the instruction shift register to the instruction parallel output. Instructions supported by the device and their respective operational binary codes are shown in [Table 13-1](#).

Table 13-1. JTAG Instruction Codes

INSTRUCTIONS	SELECTED REGISTER	INSTRUCTION CODES
EXTEST	Boundary Scan	000
IDCODE	Device Identification	001
SAMPLE/PRELOAD	Boundary Scan	010
CLAMP	Bypass	011
HIGHZ	Bypass	100
—	Bypass	101
—	Bypass	110
BYPASS	Bypass	111

SAMPLE/PRELOAD. This is a mandatory instruction for the IEEE 1149.1 specification. This instruction supports two functions. The digital I/Os of the device can be sampled at the boundary scan register without interfering with the normal operation of the device and the boundary scan register can be pre-loaded for the EXTEST instruction. The positive edge of JTCLK in the Capture-DR state samples all digital input pins into the boundary scan register. The boundary scan register is connected between JTDI and JTDO. The data on JTDI pin is clocked into the boundary scan register and the data captured in the Capture-DR state is shifted out the TDO pin in the Shift-DR state.

EXTEST. This is a mandatory instruction for the IEEE 1149.1 specification. This instruction allows testing of all interconnections to the device. When the EXTEST instruction is latched in the instruction register, the following actions occur. Once enabled by the Update-IR state, the parallel outputs of all digital output pins are driven according to the values in the boundary scan registers on the positive edge of JTCLK. The boundary scan register is connected between JTDI and JTDO. The positive edge of JTCLK in the Capture-DR state samples all digital input pins into the boundary scan register. The negative edge of JTCLK in the Update-DR state causes all of the digital output pins to be driven according to the values in the boundary scan registers that have been shifted in during the Shift-DR state. The outputs are returned to their normal mode or HIZ mode at the positive edge of JTCLK during the Update-IR state when an instruction other than EXTEST or CLAMP is activated.

BYPASS. This is a mandatory instruction for the IEEE 1149.1 specification. When the BYPASS instruction is latched into the parallel instruction register, JTDI connects to JTDO through the 1-bit bypass test register. This allows data to pass from JTDI to JTDO not affecting the device's normal operation. This mode can be used to bypass one or more chips in a system with multiple chips that have their JTAG scan chain connected in series. The chips not in bypass can then be tested with the normal JTAG modes.

IDCODE. This is a mandatory instruction for the IEEE 1149.1 specification. When the IDCODE instruction is latched into the parallel instruction register, the identification test register is selected. The device identification code is loaded into the identification register on the rising edge of JTCLK following entry into the Capture-DR state. Shift-DR can be used to shift the identification code out serially through JTDO. During Test-Logic-Reset, the identification code is forced into the instruction register's parallel output.

HIGHZ. All digital outputs are placed into a high-impedance state. The bypass register is connected between JTDI and JTDO. The outputs are put into the HIZ mode when the HIZ instruction is loaded in the Update-IR state and on the positive edge of JTCLK. The outputs are returned to their normal mode or driven from the boundary scan register at the positive edge of JTCLK during the Update-IR state when an instruction other than HIZ is activated.

CLAMP. All digital output pins output data from the boundary scan parallel output while connecting the bypass register between JTDI and JTDO. The outputs do not change during the CLAMP instruction. If the previous instruction was not EXTEST, the outputs will be driven according to the values in the boundary scan register at the positive edge of JTCLK in the Update-IR state. The typical use of this instruction is in a system that has the JTAG scan chain of multiple chips connected in series, and all of the chips have their outputs initialized using the EXTEST mode. Then some of the chips are left initialized using the CLAMP mode and others have their IO controlled using the EXTEST mode. This reduces the size of the scan chain during the partial testing of the system.

13.4 JTAG ID Codes

Table 13-2. JTAG ID Codes

DEVICE	REVISION ID[31:28]	DEVICE CODE ID[27:12]	MANUFACTURER'S CODE ID[11:1]	REQUIRED ID[0]
DS3171	Consult factory	0000000001000100	00010100001	1
DS3172	Consult factory	0000000001000101	00010100001	1
DS3173	Consult factory	0000000001000110	00010100001	1
DS3174	Consult factory	0000000001000111	00010100001	1

13.5 JTAG Functional Timing

This functional timing for the JTAG circuits shows:

- The JTAG controller starting from reset state
- Shifting out the first 4 LSB bits of the IDCODE
- Shifting in the BYPASS instruction (111) while shifting out the mandatory X01 pattern
- Shifting the TDI pin to the TDO pin through the bypass shift register
- An asynchronous reset occurs while shifting

Figure 13-3. JTAG Functional Timing

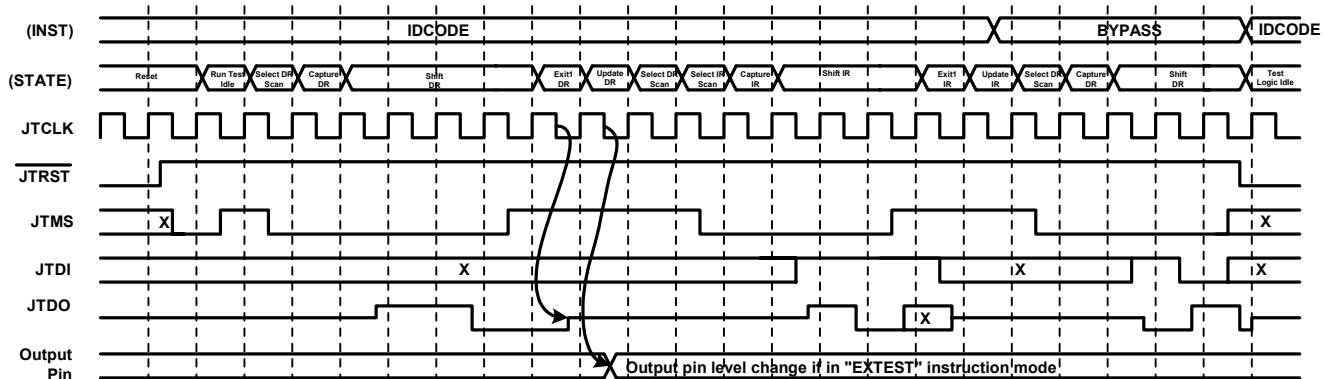

13.6 IO Pins

All input, output, and inout pins are inout pins in JTAG mode.

14 PIN ASSIGNMENTS

Table 14-1 details the breakdown of the assigned pins for each device.

Table 14-1. Pin Assignment Breakdown

	DS3174	DS3173	DS3172	DS3171
I/O Signals	154	129	104	79
Digital V _{DD}	40	40	40	40
Analog V _{DD}	13	13	13	13
V _{SS}	68	68	68	68
Total	275 assigned pins	250 assigned pins	225 assigned pins	200 assigned pins

Figure 14-1. DS3174 Pin Assignments—400-Lead PBGA

	1	2	3	4	5	6	7	8	9	10	11	12	13	14	15	16	17	18	19	20
A	VSS	VDD	RPOS1	VDD_RX3	RXN3	TXN3	TSOF01	TLCLK1			RCLKO3	RLCLK3	TCLKO3	TCLKI3	RNEG3					VSS
B	MODE	ROHSOF1	RNEG1	TCLKI1	RXP3	TXP3	TSOFI1	RLCLK1			RSER3	RSOF03		TNEG3	RPOS3	RST*				VDD
C	GPIO[5]	GPIO[6]	A[10]	TPOS1		VDD_JA3	TOHSOF1	TOHCLK1			TLCLK3	TSOF03	TSER3	TPOS3						
D	VDD_RX1	A[5]	A[9]	TNEG1	ROHCLK1		TCLKO1	TOH1	RCLKO1	ROH1	TOH3	TSOFI3		ROHSOF3						
E	A[1]	A[4]	A[8]	JTRST*	TOHEN1	TSER1	VDD_TX3	RSOF01	RSER1	ROH3	TOHCLK3	TOHSOF3	ROHCLK3	TOHEN3						
F	RXN1	RXP1	JTCLK	JTMS	GPIO[1]	VDD	VDD	VDD	VSS	VSS	VSS	VSS	VDD	VDD	VDD					
G	VDD_JA1	A[3]	A[7]	JTDO	GPIO[2]	VDD	VDD	VDD	VSS	VSS	VSS	VSS	VDD	VDD	VDD					
H	A[0]	A[2]	A[6]			VDD	VDD	VDD	VSS	VSS	VSS	VSS	VDD	VDD	VDD					
J	TXN1	TXP1	JTDI	VDD_TX1	D[15]	VSS	VSS	VSS	VSS	VSS	VSS	VSS	VSS	VSS	VSS					
K	CLKA	RDY*	RD*	WR*	VDD_CLA D	VSS	VSS	VSS	VSS	VSS	VSS	VSS	VSS	VSS	VSS					
L	CLKB	CLKC	CS*	INT*	WIDTH	VSS	VSS	VSS	VSS	VSS	VSS	VSS	VSS	VSS	VSS					
M	TXN2	TXP2	TEST*			VSS	VSS	VSS	VSS	VSS	VSS	VSS	VSS	VSS	VSS					
N	VDD_TX2	ALE	D[6]	D[11]	VDD_JA2	VDD	VDD	VDD	VSS	VSS	VSS	VSS	VDD	VDD	VDD					
P	D[0]	D[2]	D[7]	D[12]	GPIO[4]	VDD	VDD	VDD	VSS	VSS	VSS	VSS	VDD	VDD	VDD					
R	RXN2	RXP2	HIZ*	D[13]	GPIO[3]	VDD	VDD	VDD	VSS	VSS	VSS	VSS	VDD	VDD	VDD					
T	VDD_RX2	D[3]	D[8]	D[14]	TOHEN2	TSER2	VDD_TX4	RSOF02	RSER2	ROH4	TOHCLK4	TOHSOF4	ROHCLK4	TOHEN4						
U	D[1]	D[4]	D[9]	TNEG2	ROHCLK2		TCLKO2	TOH2	RCLKO2	ROH2	TOH4	TSOFI4		ROHSOF4						
V	GPIO[7]	GPIO[8]	D[10]	TPOS2		VDD_JA4	TOHSOF2	TOHCLK2			TLCLK4	TSOF04	TSER4	TPOS4						
W	VDD	D[5]	RNEG2	TCLKI2	RXP4	TXP4	TSOFI2	RLCLK2			RSER4	RSOF04		TNEG4	RPOS4					
Y	VSS	ROHSOF2	RPOS2	VDD_RX4	RXN4	TXN4	TSOF02	TLCLK2			RCLKO4	RLCLK4	TCLKO4	TCLKI4	RNEG4				VDD	VSS

Note: Green indicates V_{SS}; red indicates V_{DD}; blank cells indicate No Connect balls.

Figure 14-2. DS3173 Pin Assignments—400-Lead PBGA

	1	2	3	4	5	6	7	8	9	10	11	12	13	14	15	16	17	18	19	20
A	VSS	VDD	RPOS1	VDD_RX3	RXN3	TXN3	TSOF01	TLCLK1			RCLK03	RLCLK3	TCLK03	TCLKI3	RNEG3					VSS
B	MODE	ROHSOF1	RNEG1	TCLKI1	RXP3	TXP3	TSOFI1	RLCLK1			RSER3	RSOFO3		TNEG3	RPOS3	RST*				VDD
C	GPIO[5]	GPIO[6]	A[10]	TPOS1		VDD_JA3	TOHSOF1	TOHCLK1			TLCLK3	TSOFO3	TSER3	TPOS3						
D	VDD_RX1	A[5]	A[9]	TNEG1	ROHCLK1		TCLK01	TOH1	RCLK01	ROH1	TOH3	TSOFI3	ROHSOF3							
E	A[1]	A[4]	A[8]	JTRST*	TOHEN1	TSER1	VDD_TX3	RSOFO1	RSER1	ROH3	TOHCLK3	TOHSOF3	ROHCLK3	TOHEN3						
F	RXN1	RXP1	JTCLK	JTMS	GPIO[1]	VDD	VDD	VDD	VSS	VSS	VSS	VSS	VDD	VDD	VDD					
G	VDD_JA1	A[3]	A[7]	JTDO	GPIO[2]	VDD	VDD	VDD	VSS	VSS	VSS	VSS	VDD	VDD	VDD					
H	A[0]	A[2]	A[6]			VDD	VDD	VDD	VSS	VSS	VSS	VSS	VDD	VDD	VDD					
J	TXN1	TXP1	JTDI	VDD_TX1	D[15]	VSS	VSS	VSS	VSS	VSS	VSS	VSS	VSS	VSS	VSS					
K	CLKA	RDY*	RD*	WR*	VDD_CLA D	VSS	VSS	VSS	VSS	VSS	VSS	VSS	VSS	VSS	VSS					
L	CLKB	CLKC	CS*	INT*	WIDTH	VSS	VSS	VSS	VSS	VSS	VSS	VSS	VSS	VSS	VSS					
M	TXN2	TXP2	TEST*			VSS	VSS	VSS	VSS	VSS	VSS	VSS	VSS	VSS	VSS					
N	VDD_TX2	ALE	D[6]	D[11]	VDD_JA2	VDD	VDD	VDD	VSS	VSS	VSS	VSS	VDD	VDD	VDD					
P	D[0]	D[2]	D[7]	D[12]	GPIO[4]	VDD	VDD	VDD	VSS	VSS	VSS	VSS	VDD	VDD	VDD					
R	RXN2	RXP2	HIZ*	D[13]	GPIO[3]	VDD	VDD	VDD	VSS	VSS	VSS	VSS	VDD	VDD	VDD					
T	VDD_RX2	D[3]	D[8]	D[14]	TOHEN2	TSER2		RSOFO2	RSER2											
U	D[1]	D[4]	D[9]	TNEG2	ROHCLK2		TCLK02	TOH2	RCLK02	ROH2										
V	GPIO[7]	GPIO[8]	D[10]	TPOS2			TOHSOF2	TOHCLK2												
W	VDD	D[5]	RNEG2	TCLKI2			TSOFI2	RLCLK2												
Y	VSS	ROHSOF2	RPOS2				TSOFO2	TLCLK2											VDD	VSS

Note: Green indicates V_{SS}; red indicates V_{DD}; blank cells indicate No Connect balls.

Figure 14-3. DS3172 Pin Assignments—400-Lead PBGA

	1	2	3	4	5	6	7	8	9	10	11	12	13	14	15	16	17	18	19	20
A	VSS	VDD	RPOS1				TSOF01	TLCLK1												VSS
B	MODE	ROHSOF1	RNEG1	TCLKI1			TSOFI1	RLCLK1									RST*			VDD
C	GPIO[5]	GPIO[6]	A[10]	TPOS1			TOHSOF1	TOHCLK1												
D	VDD_RX1	A[5]	A[9]	TNEG1	ROHCLK1		TCLK01	TOH1	RCLK01	ROH1										
E	A[1]	A[4]	A[8]	JTRST*	TOHEN1	TSER1		RSOFO1	RSER1											
F	RXN1	RXP1	JTCLK	JTMS	GPIO[1]	VDD	VDD	VDD	VSS	VSS	VSS	VSS	VDD	VDD	VDD					
G	VDD_JA1	A[3]	A[7]	JTDO	GPIO[2]	VDD	VDD	VDD	VSS	VSS	VSS	VSS	VDD	VDD	VDD					
H	A[0]	A[2]	A[6]			VDD	VDD	VDD	VSS	VSS	VSS	VSS	VDD	VDD	VDD					
J	TXN1	TXP1	JTDI	VDD_TX1	D[15]	VSS	VSS	VSS	VSS	VSS	VSS	VSS	VSS	VSS	VSS					
K	CLKA	RDY*	RD*	WR*	VDD_CLA D	VSS	VSS	VSS	VSS	VSS	VSS	VSS	VSS	VSS	VSS					
L	CLKB	CLKC	CS*	INT*	WIDTH	VSS	VSS	VSS	VSS	VSS	VSS	VSS	VSS	VSS	VSS					
M	TXN2	TXP2	TEST*			VSS	VSS	VSS	VSS	VSS	VSS	VSS	VSS	VSS	VSS					
N	VDD_TX2	ALE	D[6]	D[11]	VDD_JA2	VDD	VDD	VDD	VSS	VSS	VSS	VSS	VDD	VDD	VDD					
P	D[0]	D[2]	D[7]	D[12]	GPIO[4]	VDD	VDD	VDD	VSS	VSS	VSS	VSS	VDD	VDD	VDD					
R	RXN2	RXP2	HIZ*	D[13]	GPIO[3]	VDD	VDD	VDD	VSS	VSS	VSS	VSS	VDD	VDD	VDD					
T	VDD_RX2	D[3]	D[8]	D[14]	TOHEN2	TSER2		RSOFO2	RSER2	ROH4										
U	D[1]	D[4]	D[9]	TNEG2	ROHCLK2		TCLK02	TOH2	RCLK02	ROH2										
V	GPIO[7]	GPIO[8]	D[10]	TPOS2			TOHSOF2	TOHCLK2												
W	VDD	D[5]	RNEG2	TCLKI2			TSOFI2	RLCLK2												
Y	VSS	ROHSOF2	RPOS2				TSOFO2	TLCLK2											VDD	VSS

Note: Green indicates V_{SS}; red indicates V_{DD}; blank cells indicate No Connect balls.

Figure 14-4. DS3171 Pin Assignments—400-Lead PBGA

	1	2	3	4	5	6	7	8	9	10	11	12	13	14	15	16	17	18	19	20
A	VSS	VDD	RPOS1				TSOFO1	TLCLK1												VSS
B	MODE	ROHSOF1	RNEG1	TCLK1			TSOFI1	RLCLK1								RST*				VDD
C	GPIO[5]	GPIO[6]	A[10]	TPOS1			TOHSOF1	TOHCLK1												
D	VDD_RX1	A[5]	A[9]	TNEG1	ROHCLK1		TCLKO1	TOH1	RCLKO1	ROH1										
E	A[1]	A[4]	A[8]	JTRST*	TOHEN1	TSER1		RSOFO1	RSER1											
F	RXN1	RXP1	JTCLK	JTMS	GPIO[1]	VDD	VDD	VDD	VSS	VSS	VSS	VSS	VDD	VDD	VDD					
G	VDD_JA1	A[3]	A[7]	JTDO	GPIO[2]	VDD	VDD	VDD	VSS	VSS	VSS	VSS	VDD	VDD	VDD					
H	A[0]	A[2]	A[6]			VDD	VDD	VDD	VSS	VSS	VSS	VSS	VDD	VDD	VDD					
J	TXN1	TXP1	JTDI	VDD_TX1	D[15]	VSS	VSS	VSS	VSS	VSS	VSS	VSS	VSS	VSS	VSS					
K	CLKA	RDY*	RD*	WR*	VDD_CLKA	VSS	VSS	VSS	VSS	VSS	VSS	VSS	VSS	VSS	VSS					
L	CLKB	CLKC	CS*	INT*	WIDTH	VSS	VSS	VSS	VSS	VSS	VSS	VSS	VSS	VSS	VSS					
M			TEST*			VSS	VSS	VSS	VSS	VSS	VSS	VSS	VSS	VSS	VSS					
N		ALE	D[6]	D[11]		VDD	VDD	VDD	VSS	VSS	VSS	VSS	VDD	VDD	VDD					
P	D[0]	D[2]	D[7]	D[12]	GPIO[4]	VDD	VDD	VDD	VSS	VSS	VSS	VSS	VDD	VDD	VDD					
R			HIZ*	D[13]	GPIO[3]	VDD	VDD	VDD	VSS	VSS	VSS	VSS	VDD	VDD	VDD					
T		D[3]	D[8]	D[14]																
U	D[1]	D[4]	D[9]																	
V	GPIO[7]	GPIO[8]	D[10]																	
W	VDD	D[5]																		
Y	VSS																		VDD	VSS

Note: Green indicates V_{SS}; red indicates V_{DD}; blank cells indicate No Connect balls.

15 PACKAGE INFORMATION

(The package drawing(s) in this data sheet may not reflect the most current specifications. The package number provided for each package is a link to the latest package outline information.)

15.1 400-Lead TE-PBGA (27mm x 27mm, 1.27mm Pitch) ([56-G6003-003](#))

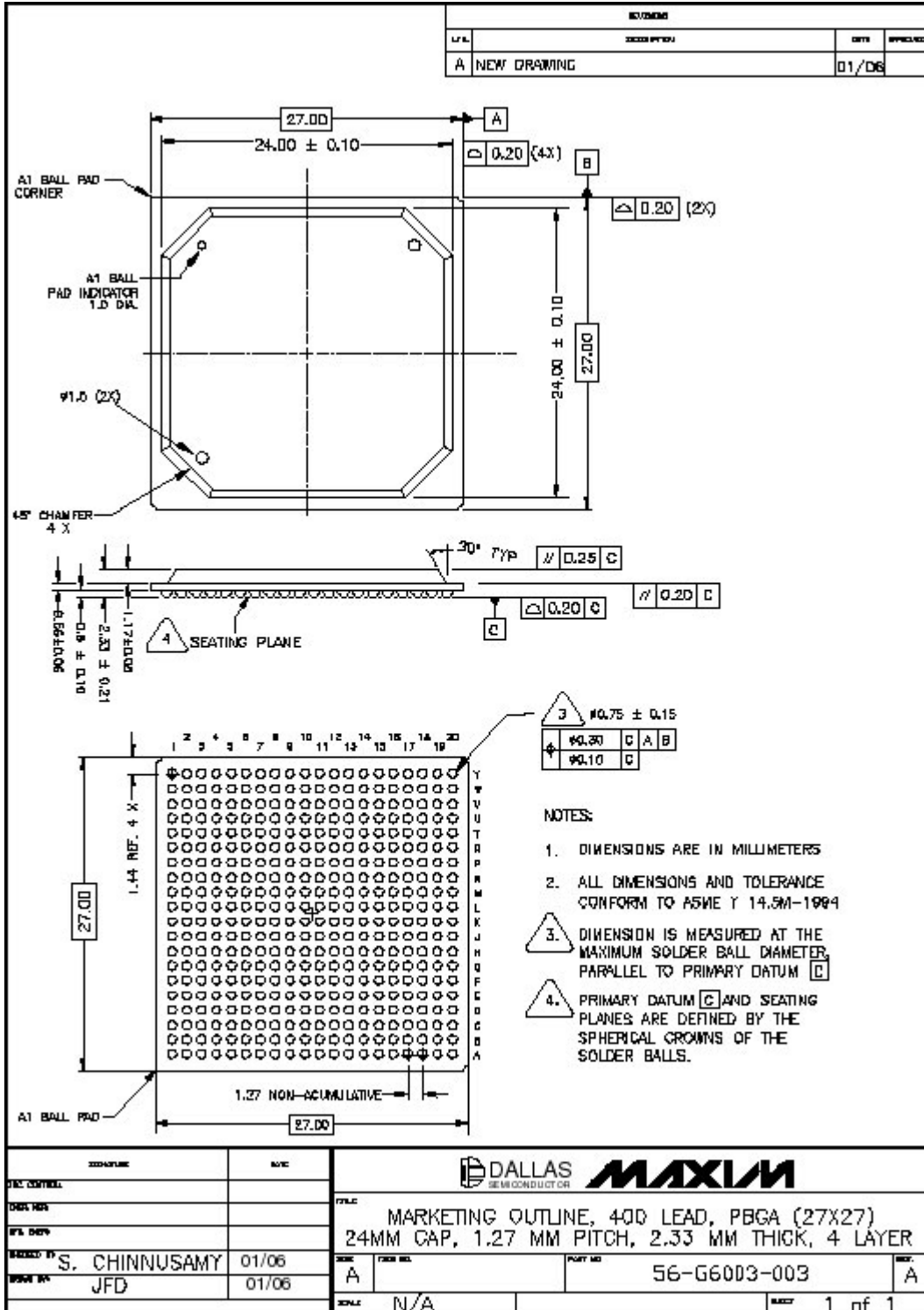

16 PACKAGE THERMAL INFORMATION

The 36 thermal V_{SS} balls in the center 6X6 matrix must be thermally and electrically connected to the internal GND plane of the PC board to achieve these thermal characteristics.

PARAMETER	VALUE
Target Ambient Temperature Range	-40°C to +85°C
Die Junction Temperature Range	-40 to +125°C
Theta-JA, Still Air	12.6 °C/W (Note 1)

Note 1: Theta-JA is based on the package mounted on a 4-layer JEDEC board and measured in a JEDEC test chamber.

17 DC ELECTRICAL CHARACTERISTICS

ABSOLUTE MAXIMUM RATINGS

Voltage Range on Any Input, Bidirectional or Open Drain

Output Lead with Respect to V_{SS}	-0.3V to +5.5V
Supply Voltage (V_{DD}) Range with Respect to V_{SS}	-0.3V to +3.63V
Ambient Operating Temperature Range.....	-40°C to +85°C
Junction Operating Temperature Range.....	-40°C to +125°C
Storage Temperature Range.....	-55°C to +125°C
Soldering Temperature.....	See IPC/JEDEC J-STD-020 Standard

These are stress ratings only and functional operation of the device at these or any other conditions beyond those indicated in the operation sections of this specification is not implied. Exposure to absolute maximum rating conditions for extended periods of time can affect device reliability. Ambient Operating Temperature Range is assuming the device is mounted on a JEDEC standard test board in a convection cooled JEDEC test enclosure.

Note: The typical values listed below are not production tested.

Table 17-1. Recommended DC Operating Conditions

($V_{DD} = 3.3V \pm 5\%$, $T_j = -40^\circ C$ to $+85^\circ C$.)

PARAMETER	SYMBOL	CONDITIONS	MIN	TYP	MAX	UNITS
Logic 1	V_{IH}		2.0		5.5	V
Logic 0	V_{IL}		-0.3		+0.8	V
Supply (V_{DD}) $\pm 5\%$	V_{DD}		3.135	3.300	3.465	V

Table 17-2. DC Electrical Characteristics

($T_j = -40^\circ C$ to $+85^\circ C$)

PARAMETER	SYMBOL	CONDITIONS	MIN	TYP	MAX	UNITS
Supply Current ($V_{DD} = 3.465V$) (Note 1)	I_{DD}	DS3174			725	mA
		DS3173			449	
		DS3172			328	
		DS3171			273	
Power-Down Current (All DISABLE Bits Set) (Note 2)	I_{DDD}	DS3174			68	mA
		DS3173			52	
		DS3172			36	
		DS3171			21	
Lead Capacitance	C_{IO}			7		pF
Input Leakage	I_{IL}		-10		+10	μA
Input Leakage (Input Pins with Internal Pullup Resistors)	I_{ILP}		-350		+10	μA
Output Leakage (when Hi-Z)	I_{LO}		-10		+10	μA
Output Voltage ($I_{OH} = -4.0mA$)	V_{OH}	4mA outputs	2.4			V
Output Voltage ($I_{OL} = +4.0mA$)	V_{OL}	4mA outputs			0.4	V
Output Voltage ($I_{OH} = -8.0mA$)	V_{OH}	8mA outputs	2.4			V
Output Voltage ($I_{OL} = +8.0mA$)	V_{OL}	8mA outputs			0.4	V

Note 1: Mode: DS3 data rate, transmitting all ones on the LIU, all clocks = 45MHz, digital outputs without load; all inputs between V_{DD} and V_{SS} ; inputs with pullups connected to V_{DD} .

Note 2: All outputs loaded with rated capacitance; all inputs between V_{DD} and V_{SS} ; inputs with pullups connected to V_{DD} .

Table 17-3. Output Pin Drive

PIN NAME	TYPE	DRIVE STRENGTH (mA)
TLCLKn	O	6
TPOSn/TDATn	O	6
TNEGn	O	6
TXPn	O	N/A (analog)
TXNn	O	N/A (analog)
TOHCLKn	O	4
TOHSOFn	O	4
ROHn	O	4
ROHCLKn	O	4
ROHSOFn	O	4
TCLKOn/TGCLKn	O	6
TSOFOOn/TDENn	O	6
RSErn	O	6
RCLKOn/RGCLKn	O	6
RSOFOOn/RDENn	O	6
D[15:0]	IO	4
RDY	Oz	6
INT	Oz	6
GPIO[7:0]	IO	4
JTDO	Oz	4
CLKB	IO	6
CLKC	IO	6

18 AC TIMING CHARACTERISTICS

There are several common AC characteristic definitions. These generic definitions are shown below in [Figure 18-1](#), [Figure 18-2](#), [Figure 18-3](#), and [Figure 18-4](#). Definitions that are specific to a given interface are shown in that interface's subsection.

Figure 18-1. Clock Period and Duty Cycle Definitions

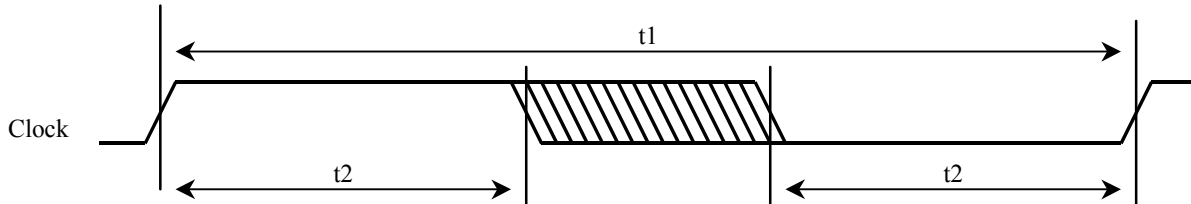

Figure 18-2. Rise Time, Fall Time, and Jitter Definitions

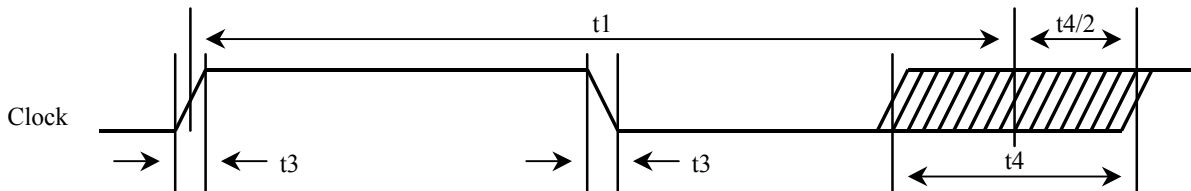

Figure 18-3. Hold, Setup, and Delay Definitions (Rising Clock Edge)

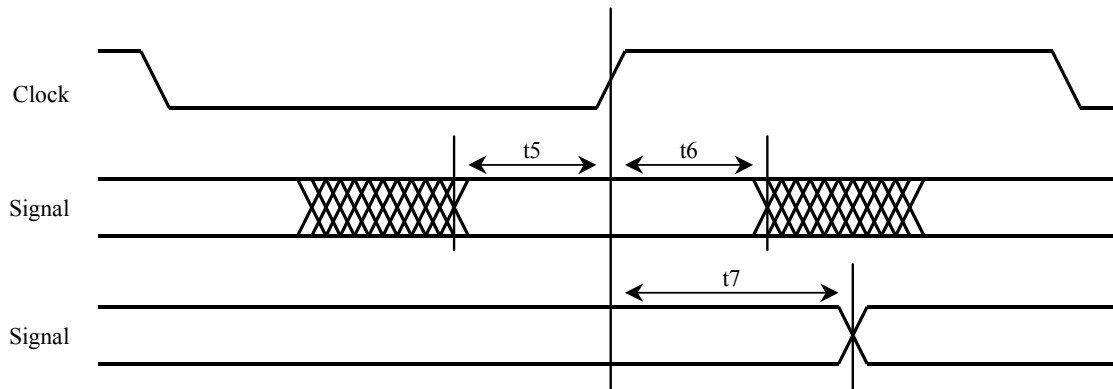
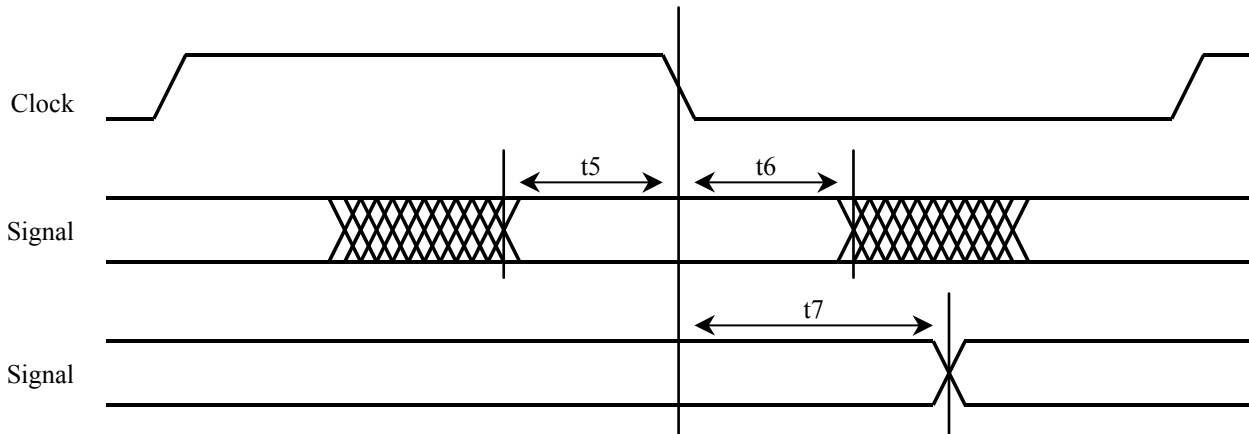
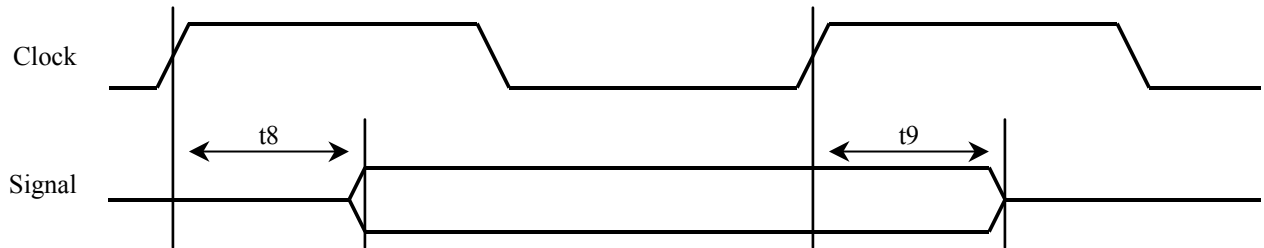
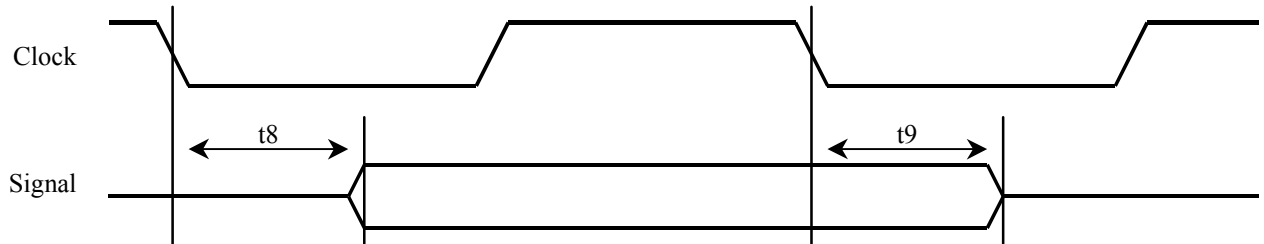

Figure 18-4. Hold, Setup, and Delay Definitions (Falling Clock Edge)**Figure 18-5. To/From Hi Z Delay Definitions (Rising Clock Edge)****Figure 18-6. To/From Hi Z Delay Definitions (Falling Clock Edge)**

18.1 Framer AC Characteristics

All AC timing characteristics are specified with a 25 pF capacitive load on all output pins, $V_{IH} = 2.4V$ and $V_{IL} = 0.8V$. The voltage threshold for all timing measurements is $V_{DD}/2$. The generic timing definitions shown in [Figure 18-1](#), [Figure 18-2](#), [Figure 18-3](#), and [Figure 18-6](#) apply to this interface.

Table 18-1. Framer Port Timing

($V_{DD} = 3.3V \pm 5\%$, $T_j = -40^\circ C$ to $+85^\circ C$.)

PARAMETER	SYMBOL	CONDITIONS	MIN	TYP	MAX	UNITS
CLK Period	t1	Note 1	19.23			ns
CLK Clock Duty Cycle (t2/t1)	t2/t1	Note 2	40	50	60	%
CLK Rise or Fall Times (20% to 80%)	t3	Note 2			4	ns
DIN to CLK Setup Time	t5	Note 3	3			ns
		Note 4	7			ns
CLK to DIN Hold Time	t6	Note 3	1			ns
		Note 4	1			ns
CLK to DOUT Delay	t7	Note 5	2		11	ns
		Note 6	2		9	ns

Note 1: Any mode, 52MHz TCLKIn, RLCLKn input clocks.

Note 2: Any mode, TCLKIn, RLCLKn input clocks.

Note 3: TCLKIn, RLCLKn clock inputs to TOHMIIn/TSOFIIn, TFOHn/TSERn inputs.

Note 4: TCLKOn, RCLKOn clock outputs to TOHMIIn/TSOFIIn, TFOHn/TSERn inputs.

Note 5: TCLKIn, RLCLKn clock input to TSOFOIn/TDENn, RSERn, RSOFOIn/RDENn outputs.

Note 6: TCLKOn, RCLKOn clock output to TSOFOIn/TDENn, RSERn, RSOFOIn/RDENn outputs.

18.2 Line Interface AC Characteristics

All AC timing characteristics are specified with a 25 pF capacitive load on all output pins, $V_{IH} = 2.4V$ and $V_{IL} = 0.8V$. The voltage threshold for all timing measurements is $V_{DD}/2$. The generic timing definitions shown in [Figure 18-1](#), [Figure 18-2](#), [Figure 18-3](#), and [Figure 18-6](#) apply to this interface.

Table 18-2. Line Interface Timing

($V_{DD} = 3.3V \pm 5\%$, $T_j = -40^\circ C$ to $+85^\circ C$.)

PARAMETER	SYMBOL	CONDITIONS	MIN	TYP	MAX	UNITS
CLK Period	t1	Note 1	19.23			ns
CLK Clock Duty Cycle (t2/t1)	t2/t1	Note 2	40	50	60	%
CLK Rise or Fall Times (20% to 80%)	t3	Note 2			4	ns
DIN to CLK Setup Time	t5	Note 3	4			ns
CLK to DIN Hold Time	t6	Note 3	0			ns
CLK to DOUT Delay	t7	Note 4	2		10	ns
		Note 5	2		8	ns

Note 1: Any mode, 52MHz TCLKIn, RLCLKn input clocks.

Note 2: Any mode, TCLKIn, RLCLKn input clocks.

Note 3: RLCLKn clock inputs to RPOSn/RDATn, RNEGn/RLCVn/ROHMIIn inputs.

Note 4: TCLKIn, RLCLKn clock input to TPOSn/TDATn, TNEGn/TOHMOIn outputs.

Note 5: TLCLKn, TCLKOn, RCLKOn clock output to TPOSn/TDATn, TNEGn/TOHMOIn outputs.

18.3 Misc Pin AC Characteristics

All AC timing characteristics are specified with a 25 pF capacitive load on all output pins, $V_{IH} = 2.4V$ and $V_{IL} = 0.8V$. The voltage threshold for all timing measurements is $V_{DD}/2$. The generic timing definitions shown in [Figure 18-1](#), [Figure 18-2](#), [Figure 18-3](#), and [Figure 18-6](#) apply to this interface.

Table 18-3. Misc Pin Timing

($V_{DD} = 3.3V \pm 5\%$, $T_j = -40^\circ C$ to $+85^\circ C$.)

PARAMETER	SYMBOL	CONDITIONS	MIN	TYP	MAX	UNITS
Asynchronous Input High, Low Time	t1-t2, t2	Note 1	500			ns
Asynchronous Input Rise, Fall Time	t3	Note 1			10	ns

Note 1: TMEI (GPIO), PMU(GPIO), 8KREFI(GPIO) and \overline{RST} inputs.

18.4 Overhead Port AC Characteristics

All AC timing characteristics are specified with a 25 pF capacitive load on all output pins, $V_{IH} = 2.4V$ and $V_{IL} = 0.8$. The voltage threshold for all timing measurements is $V_{DD}/2$. The generic timing definitions shown in [Figure 18-1](#), [Figure 18-2](#), [Figure 18-3](#), and [Figure 18-6](#) apply to this interface.

Table 18-4. Overhead Port Timing

($V_{DD} = 3.3V \pm 5\%$, $T_j = -40^\circ C$ to $+125^\circ C$.)

PARAMETER	SYMBOL	CONDITIONS	MIN	TYP	MAX	UNITS
CLK Period	t1	Note 1	500			ns
CLK Clock high and low time	t1-t2, t2	Note 1	200			ns
DIN to CLK Setup Time	t5	Note 2	20			ns
CLK to DIN Hold Time	t6	Note 2	20			ns
CLK to DOUT Delay	t7	Note 3	-20		20	ns

Note 1: TOHCLKn, ROHCLKn output clocks.

Note 2: TOHCLKn clock falling edge outputs to TOHn, TOHENn inputs.

Note 3: TOHCLKn, ROHCLKn clock falling edge outputs to TOHSOFn, ROHn, ROHSOF outputs.

18.5 Micro Interface AC Characteristics

The AC characteristics for the external bus interface. This table references [Figure 18-7](#) and [Figure 18-8](#).

Table 18-5. Micro Interface Timing

($V_{DD} = 3.3 \pm 5\%$, $T_j = -40^\circ\text{C}$ to $+125^\circ\text{C}$.)

SIGNAL NAME(S)	SYMBOL	DESCRIPTION	MIN	TYP	MAX	UNITS	NOTES
A[10:0]	t1a	Setup Time to \overline{RD} , \overline{WR} , \overline{DS} Active	10			ns	1
ALE	t1b	Setup Time to \overline{RD} , \overline{WR} , \overline{DS} Active	10			ns	1, 2
A[10:0]	t2	Setup Time to ALE Inactive	2			ns	1, 2
A[10:0]	t3	Hold Time from ALE Inactive	2			ns	1, 2
ALE	t4	Pulse Width	5			ns	1, 2
A[N:0], ALE	t5	Hold Time from \overline{RD} , \overline{WR} , \overline{DS} Inactive	0			ns	1
\overline{CS} , $\overline{R\overline{W}}$	t6	Setup Time to \overline{RD} , \overline{WR} Active	0			ns	1
D[15:0]	t8	Output Delay Time from \overline{RD} , \overline{DS} Active			30	ns	1
\overline{RD} , \overline{WR} , \overline{DS}	t9a	Pulse Width if not using RDY Handshake	35			ns	1, 4
\overline{RD} , \overline{WR} , \overline{DS}	t9b	Delay from RDY	15			ns	1
D[15:0]	t10	Output Deassert Delay Time from \overline{RD} , \overline{DS} Inactive	2		10	ns	1, 3
\overline{CS} , $\overline{R\overline{W}}$	t12	Hold Time from \overline{RD} , \overline{WR} , \overline{DS} Inactive	0			ns	1
D[15:0]	t13	Input Setup Time to \overline{WR} , \overline{DS} Inactive	10			ns	1
D[15:0]	t14	Input Hold Time from \overline{WR} , \overline{DS} Inactive	5			ns	1
RDY	t15	Delay Time from \overline{RD} , \overline{WR} , \overline{DS} Active	5			ns	1
RDY	t16	Delay Time from \overline{RD} , \overline{WR} , \overline{DS} Inactive	0			ns	1
RDY	t17	Enable Delay Time from \overline{CS} Active			12	ns	1
RDY	t18	Disable Delay Time from \overline{CS} Inactive			10	ns	1
RDY	t19	Ending High Pulse Width	1			ns	1
$\overline{R\overline{W}}$	t20	Setup Time to \overline{DS} Active	2			ns	1
$\overline{R\overline{W}}$	t21	Hold Time to \overline{DS} Inactive	2			ns	1

Note 1: The input/output timing reference level for all signals is $V_{DD}/2$. Transition time (80/20%) on \overline{RD} , \overline{WR} , and \overline{CS} inputs is 5ns max.

Note 2: Multiplexed mode timing only.

Note 3: D[15:0] output valid until not driven.

Note 4: Timing required if not using RDY handshake.

Figure 18-7. Micro Interface Nonmultiplexed Read/Write Cycle

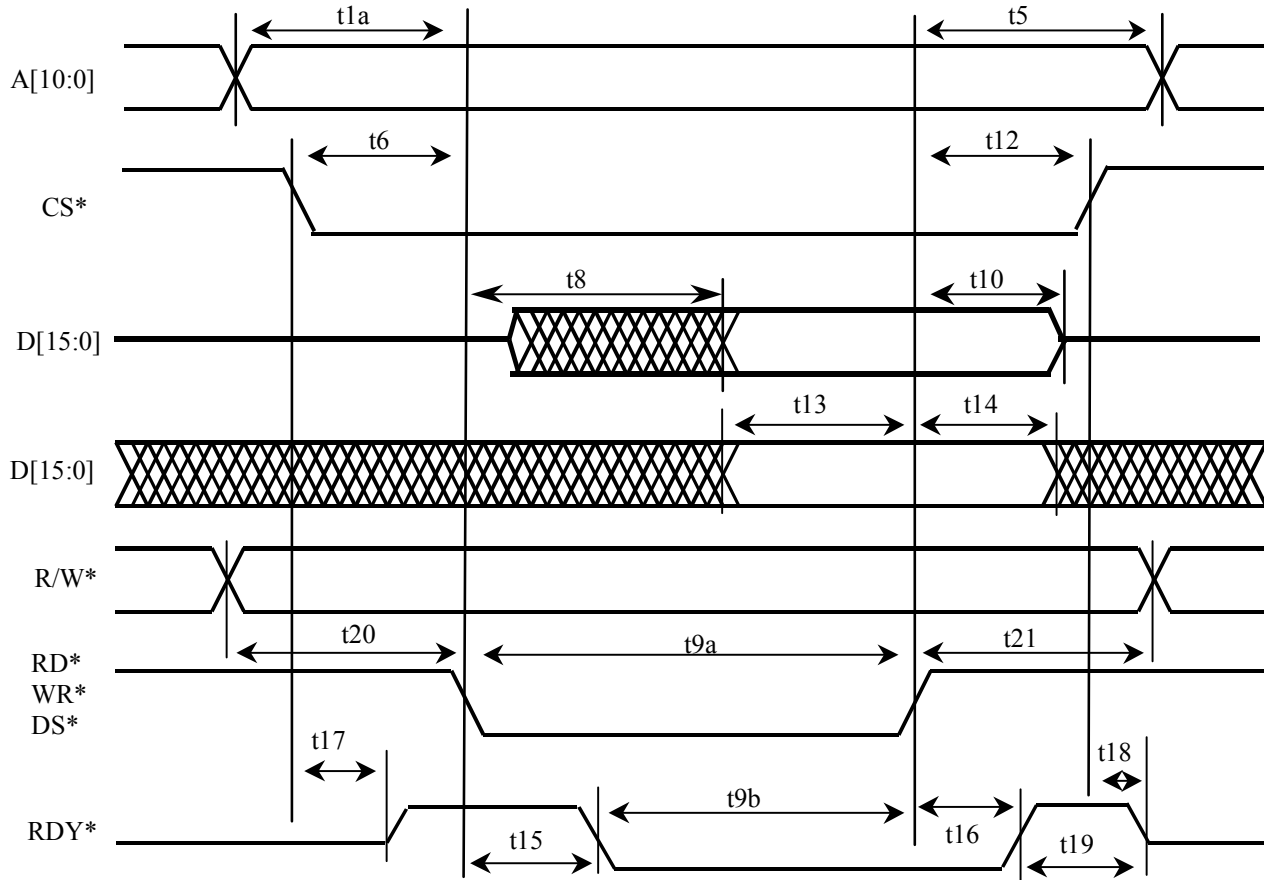
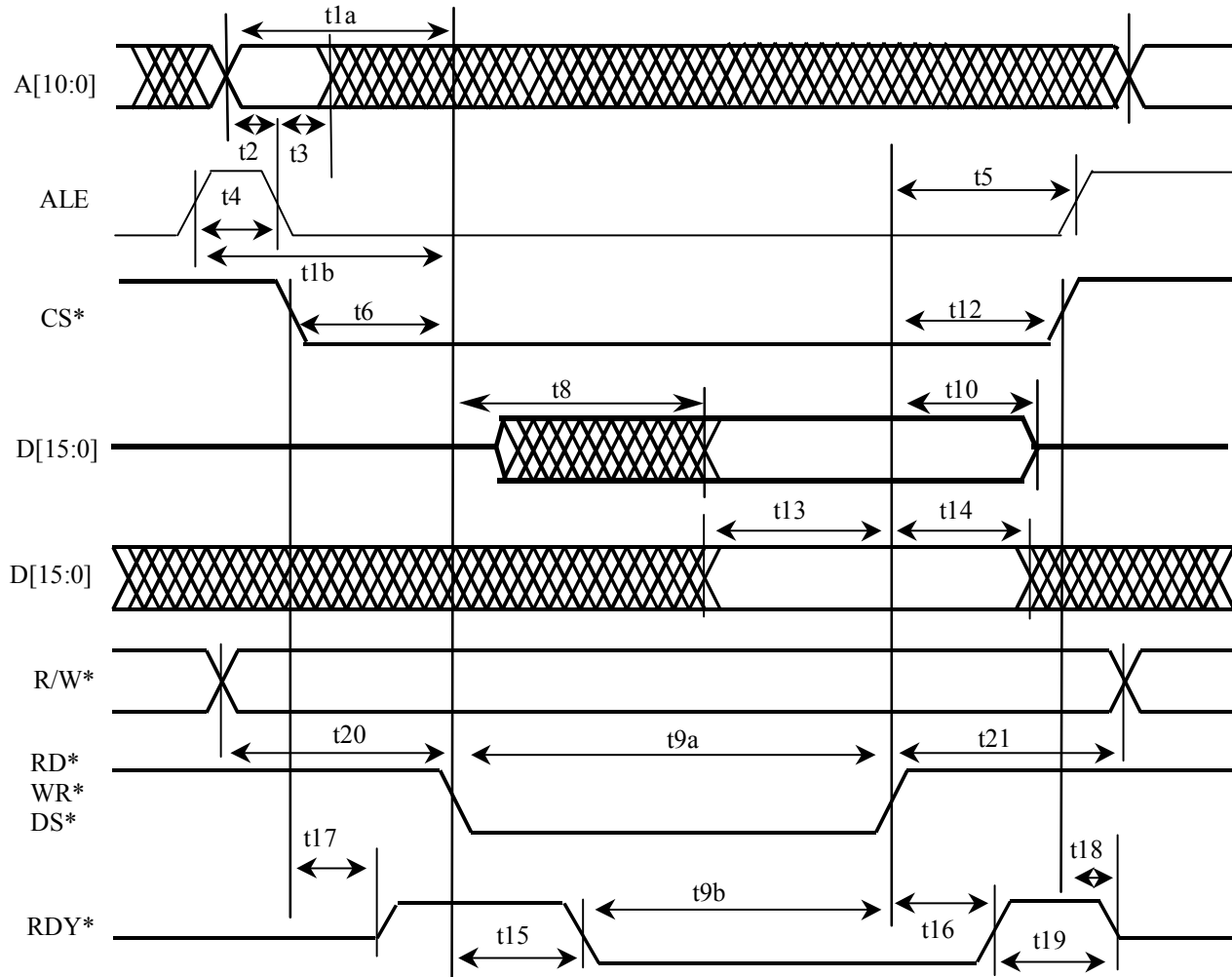

Figure 18-8. Micro Interface Multiplexed Read Cycle



18.6 CLAD Jitter Characteristics

PARAMETER	MIN	TYP	MAX	UNITS
Intrinsic Jitter ($UI_{P,P}$)			0.025	$UI_{P,P}$
Intrinsic Jitter (UI_{RMS})			0.0045	UI_{RMS}
Peak Jitter Transfer			1.75	dB

18.7 LIU Interface AC Characteristics

18.7.1 Waveform Templates

Table 18-6. DS3 Waveform Template

TIME (IN UNIT INTERVALS)	NORMALIZED AMPLITUDE EQUATION
UPPER CURVE	
$-0.85 \leq T \leq -0.68$	0.03
$-0.68 \leq T \leq +0.36$	$0.5 \{1 + \sin[(\pi / 2)(1 + T / 0.34)]\} + 0.03$
$0.36 \leq T \leq 1.4$	$0.08 + 0.407e^{-1.84(T - 0.36)}$
LOWER CURVE	
$-0.85 \leq T \leq -0.36$	-0.03
$-0.36 \leq T \leq +0.36$	$0.5 \{1 + \sin[(\pi / 2)(1 + T / 0.18)]\} - 0.03$
$0.36 \leq T \leq 1.4$	-0.03

Governing Specifications: ANSI T1.102 and Bellcore GR-499.

Table 18-7. DS3 Waveform Test Parameters and Limits

PARAMETER	SPECIFICATION
Rate	44.736Mbps (± 20 ppm)
Line Code	B3ZS
Transmission Medium	Coaxial cable (AT&T 734A or equivalent)
Test Measurement Point	At the end of 0 to 450ft of coaxial cable
Test Termination	75Ω ($\pm 1\%$) resistive
Pulse Amplitude	Between 0.36V and 0.85V
Pulse Shape	An isolated pulse (preceded by two zeros and followed by one or more zeros) falls within the curves listed in Figure 18-9 .
Unframed All-Ones Power Level at 22.368MHz	Between -1.8dBm and +5.7dBm
Unframed All-Ones Power Level at 44.736MHz	At least 20dB less than the power measured at 22.368MHz
Pulse Imbalance of Isolated Pulses	Ratio of positive and negative pulses must be between 0.90 and 1.10.

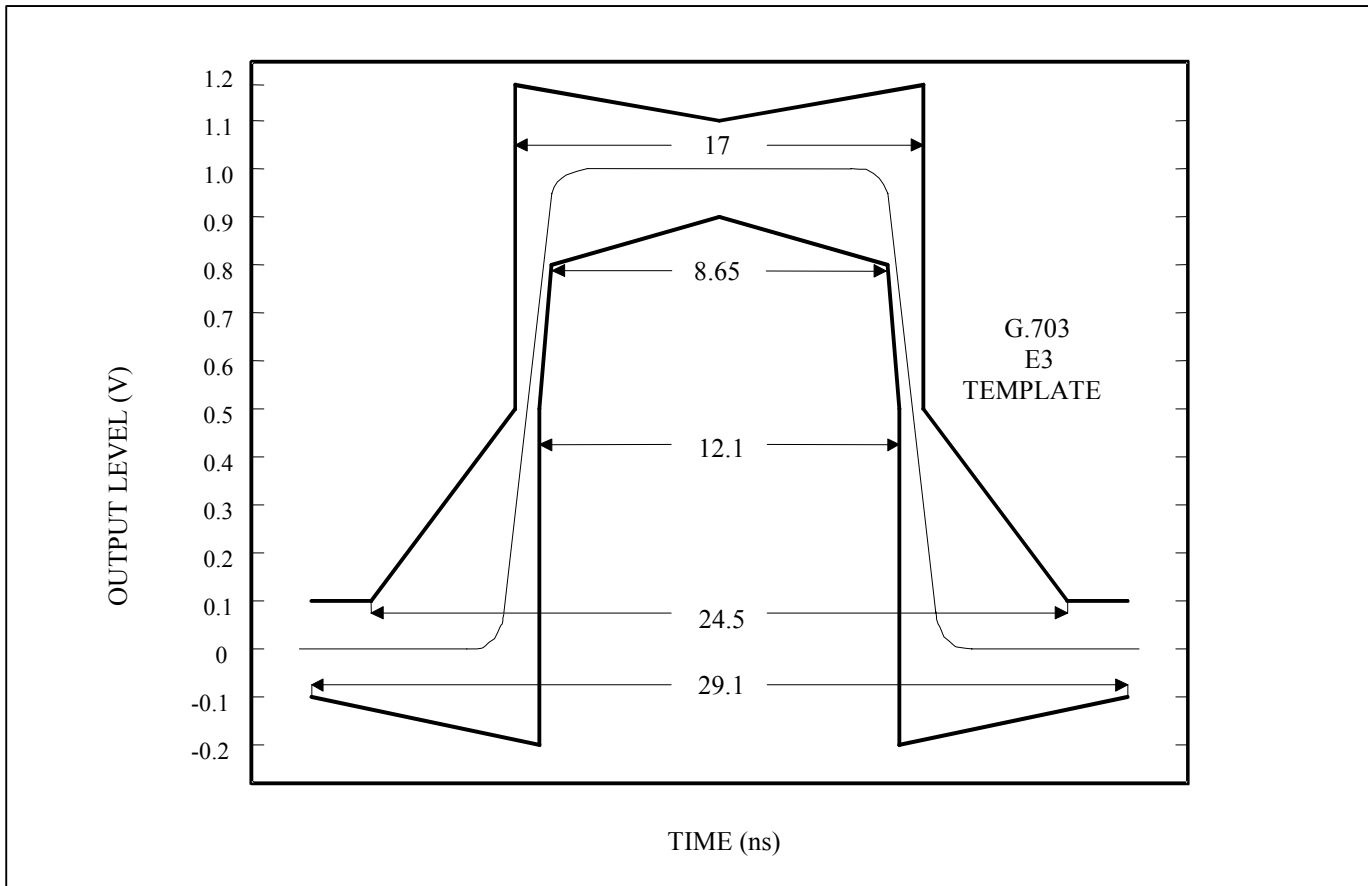
Figure 18-9. E3 Waveform Template**Table 18-8. E3 Waveform Test Parameters and Limits**

PARAMETER	SPECIFICATION
Rate	34.368Mbps (± 20 ppm)
Line Code	HDB3
Transmission Medium	Coaxial cable (AT&T 734A or equivalent)
Test Measurement Point	At the transmitter
Test Termination	75 Ω ($\pm 1\%$) resistive
Pulse Amplitude	1.0V (nominal)
Pulse Shape	An isolated pulse (preceded by two zeros and followed by one or more zeros) falls within the template shown in Figure 18-9 .
Ratio of the Amplitudes of Positive and Negative Pulses at the Center of the Pulse Interval	0.95 to 1.05
Ratio of the Widths of Positive and Negative Pulses at the Nominal Half Amplitude	0.95 to 1.05

Figure 18-10. DS3 Pulse Mask Template

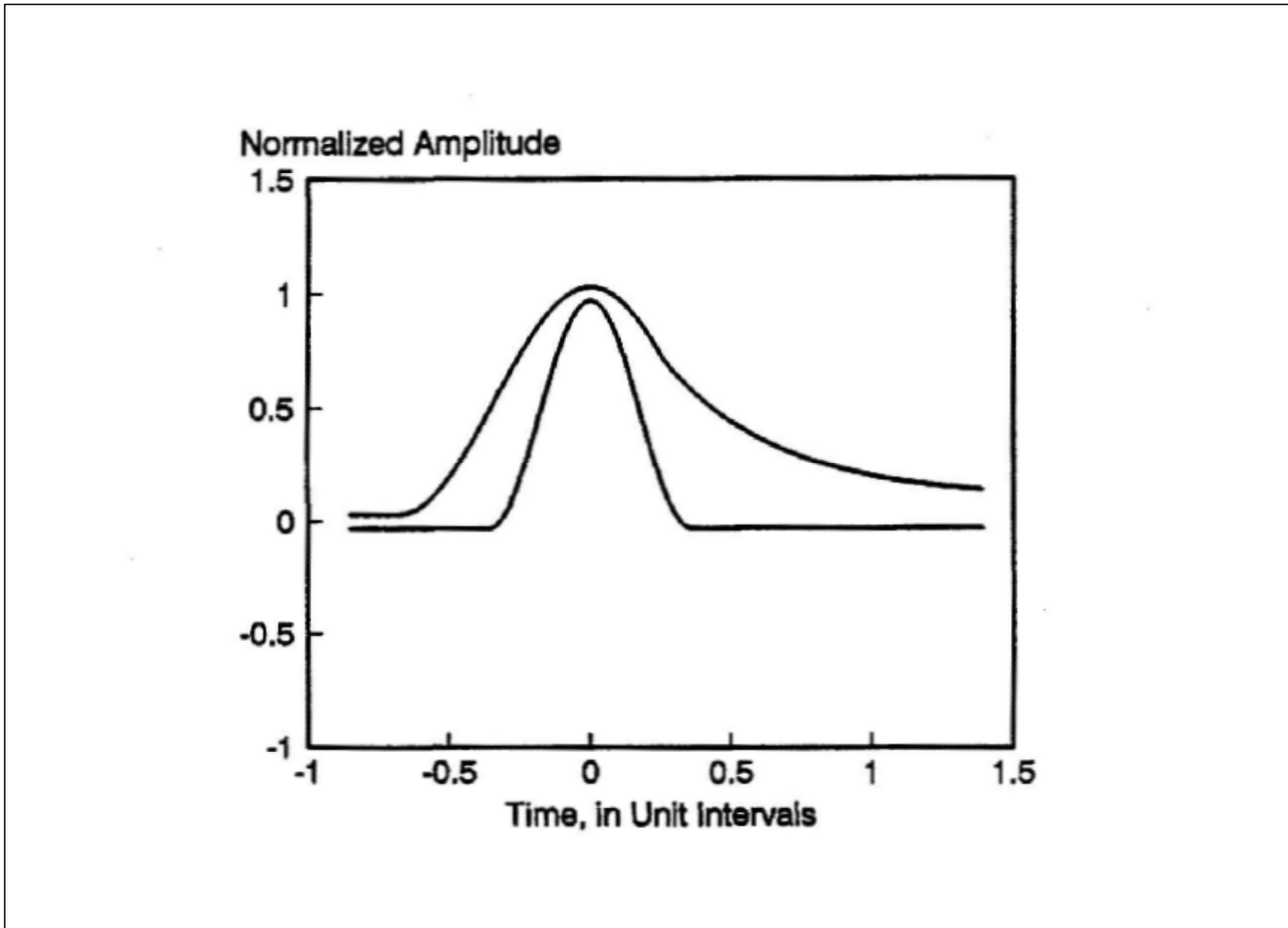

18.7.2 LIU Input/Output Characteristics

Table 18-9. Receiver Input Characteristics—DS3 Mode

($V_{DD} = 3.3V \pm 5\%$, $T_A = -40^\circ C$ to $+85^\circ C$.)

PARAMETER	MIN	TYP	MAX	UNITS
Receive Sensitivity (Length of Cable)	900	1200		ft
Signal-to-Noise Ratio, Interfering Signal Test (Notes 1, 2)		10		
Input Pulse Amplitude, RMON = 0 (Notes 2, 3)			1000	mVpk
Input Pulse Amplitude, RMON = 1 (Notes 2, 3)			200	mVpk
Analog LOS Declare, RMON = 0 (Note 4)		-24	-28	dB
Analog LOS Clear, RMON = 0 (Note 4)	-16	-17		dB
Analog LOS Declare, RMON = 1 (Note 4)			-38	dB
Analog LOS Clear, RMON = 1 (Note 4)	-29			dB
Intrinsic Jitter Generation (Note 2)		0.03		UI _{P-P}

Table 18-10. Receiver Input Characteristics—E3 Mode(V_{DD} = 3.3V ±5%, T_A = -40°C to +85°C.)

PARAMETER	MIN	TYP	MAX	UNITS
Receive Sensitivity (Length of Cable)	900	1200		ft
Signal-to-Noise Ratio, Interfering Signal Test (Notes 2, 3)		12		
Input Pulse Amplitude, RMON = 0 (Notes 2, 3)			1300	mVpk
Input Pulse Amplitude, RMON = 1 (Notes 2, 3)			260	mVpk
Analog LOS Declare, RMON = 0 (Note 4)		-24	-28	dB
Analog LOS Clear, RMON = 0 (Note 4)	-16	-17		dB
Analog LOS Declare, RMON = 1 (Note 4)			-38	dB
Analog LOS Clear, RMON = 1 (Note 4)	-29			dB
Intrinsic Jitter Generation (Note 2)		0.03		UI _{P,P}

Note 1: An interfering signal ($2^{15} - 1$ PRBS for DS3, $2^{23} - 1$ PRBS for E3, B3ZS/HDB3 encoded, compliant waveshape, nominal bit rate) is added to the wanted signal. The combined signal is passed through 0 to 900ft of coaxial cable and presented to the LIU. This spec indicates the lowest signal-to-noise ratio that results in a bit error ratio $\leq 10^{-9}$.

Note 2: Not tested during production test.

Note 3: Measured on the line side (i.e., the BNC connector side) of the 1:2 receive transformer (Figure 1-1). During measurement, incoming data traffic is unframed $2^{15} - 1$ PRBS for DS3 and unframed $2^{23} - 1$ PRBS for E3.

Note 4: With respect to nominal 800mVpk signal for DS3 and nominal 1000mVpk signal for E3.

Table 18-11. Transmitter Output Characteristics—DS3 Modes(V_{DD} = 3.3V ±5%, T_A = -40°C to +85°C.)

PARAMETER	MIN	TYP	MAX	UNITS
DS3 Output Pulse Amplitude, TLBO = 0 (Note 5)	700	800	900	mVpk
DS3 Output Pulse Amplitude, TLBO = 1 (Note 5)	520	700	800	mVpk
Ratio of Positive and Negative Pulse-Peak Amplitudes	0.9		1.1	
DS3 Unframed All-Ones Power Level at 22.368MHz, 3kHz Bandwidth	-1.8		+5.7	dBm
DS3 Unframed All-Ones Power Level at 44.736MHz vs. Power Level at 22.368MHz, 3kHz Bandwidth			-20	dB
Intrinsic Jitter Generation (Note 6)		0.02	0.05	UI _{P,P}

Table 18-12. Transmitter Output Characteristics—E3 Mode(V_{DD} = 3.3V ±5%, T_A = -40°C to +85°C.)

PARAMETER	MIN	TYP	MAX	UNITS
Output Pulse Amplitude (Note 5)	900	1000	1100	mVpk
Pulse Width		14.55		ns
Ratio of Positive and Negative Pulse Amplitudes (at Centers of Pulses)	0.95		1.05	
Ratio of Positive and Negative Pulse Widths (at Nominal Half Amplitude)	0.95		1.05	
Intrinsic Jitter Generation (Note 6)		0.02	0.05	UI _{P,P}

Note 5: Measured on the line side (i.e., the BNC connector side) of the 2:1 transmit transformer (Figure 1-1).

Note 6: Measured with jitter-free clock applied to TCLK and a bandpass jitter filter with 10Hz and 800kHz cutoff frequencies. Not tested during production test.

18.8 JTAG Interface AC Characteristics

All AC timing characteristics are specified with a 50pF capacitive load on JTDO pin and 25pF capacitive load on all other digital output pins, $V_{IH} = 2.4V$ and $V_{IL} = 0.8$. The voltage threshold for all timing measurements is $V_{DD}/2$. The generic timing definitions shown [Figure 18-1](#), [Figure 18-2](#), [Figure 18-3](#), [Figure 18-5](#), and [Figure 18-6](#) apply to this interface.

Table 18-13. JTAG Interface Timing

($V_{DD} = 3.3V \pm 5\%$, $T_j = -40^{\circ}C$ to $+125^{\circ}C$.)

SIGNAL NAME(S)	SYMBOL	DESCRIPTION	MIN	TYP	MAX	UNITS	NOTES
JTCLK	f1	Clock Frequency (1/t1)	0		10	MHz	
JTCLK	t2	Clock High or Low Period	20			ns	
JTCLK	t3	Rise/Fall Times			5	ns	
JTMS and JTDI	t5	Hold Time from JTCLK Rising Edge	10			ns	
JTMS and JTDI	t6	Setup Time to JTCLK Rising Edge	10			ns	
JTDO	t7	Delay from JTCLK Falling Edge	0		20	ns	
JTDO	t8	Delay out of HiZ from JTCLK Falling Edge	0		20	ns	
JTDO	t9	Delay to HiZ from JTCLK Falling Edge	0		20	ns	
Any digital output	t7	Delay from JTCLK Falling Edge	0		20	ns	1
Any digital output	t7	Delay from JTCLK Rising Edge	0		20	ns	2
Any digital output	t8	Delay out of HiZ from JTCLK Falling Edge	0		20	ns	1
Any digital output	t9	Delay into HiZ from JTCLK Falling Edge	0		20	ns	1
Any digital output	t8	Delay out of HiZ from JTCLK Rising Edge	0		20	ns	2, 3
Any digital output	t9	Delay into HiZ from JTCLK Rising Edge	0		20	ns	2, 3

Note 1: Change during Update-DR state.

Note 2: Change during Update-IR state to or from EXTEST mode.

Note 3: Change during Update-IR state to or from HiZ mode.

19 REVISION HISTORY

DATE	DESCRIPTION
102204	New product release.
030205	Updated power numbers in the DC Characteristics table. Fixed wording of use of unused bits located in <i>Overall Register Map</i> section. Added I _{DD} numbers for the DS3171/DS3172/DS3173.
110206	Added lead-free package note to <i>Ordering Information</i> table (page 1). Updated Package Information (Section 15).

Note: To obtain a revision history for the preliminary releases of this document, contact the factory at telecom.support@dalsemi.com.

Maxim/Dallas Semiconductor cannot assume responsibility for use of any circuitry other than circuitry entirely embodied in a Maxim/Dallas Semiconductor product. No circuit patent licenses are implied. Maxim/Dallas Semiconductor reserves the right to change the circuitry and specifications without notice at any time.



Maxim Integrated Products, 120 San Gabriel Drive, Sunnyvale, CA 94086 408-737-7600

© 2006 Maxim Integrated Products

The Maxim logo is a registered trademark of Maxim Integrated Products, Inc. The Dallas logo is a registered trademark of Dallas Semiconductor.

Looking for pricing, stock, or lifecycle information?

Click below to explore more details on WIN SOURCE:

-  [View DS3172+ on WIN SOURCE](#)
-  [Maxim Integrated Information](#)

Optimize Your Supply Chain with WIN SOURCE Solutions

-  Global Sourcing Solution
-  Obsolete Management
-  Cost Control Management
-  Shortage Management
-  Alternative Solution
-  Excess Inventory Management