

FEATURES

- 16 or 12 completely independent E1 framers in one small 27mm x 27mm package
- Each multichip module (MCM) contains either four (FF) or three (FT) DS21Q44 die
- Each quad framer can be concatenated into a single 8.192MHz backplane data stream
- IEEE 1149.1 JTAG-Boundary Scan Architecture
- DS21FF44 and DS21FT44 are pin compatible with DS21FF42 and DS21FT42, respectively, to allow the same footprint to support T1 and E1 applications
- 300-pin MCM BGA 1.27mm pitch package (27mm x 27mm)
- Low-power 3.3V CMOS with 5V tolerant input and outputs

APPLICATIONS

- DSLAMs
- Multiplexers/Demultiplexers
- Switches
- High-Density Line Cards

ORDERING INFORMATION

PART	CHANNEL	PIN-PACKAGE	TEMP. RANGE
DS21FT44	12	300-BGA, 27mm x 27mm	0°C to +70°C
DS21FT44N	12	300-BGA, 27mm x 27mm	-40°C to +85°C
DS21FF44	16	300-BGA, 27mm x 27mm	0°C to +70°C
DS21FF44N	16	300-BGA, 27mm x 27mm	-40°C to +85°C

1. DESCRIPTION

The 4 x 4 and 4 x 3 MCMs offer a high-density packaging arrangement for the DS21Q44 E1 enhanced quad framer. Either three (DS21FT44) or four (DS21FF44) silicon die of these devices is packaged in a multichip module (MCM) with the electrical connections as shown in Figure 1-1.

All of the functions available on the DS21Q44 are also available in the MCM packaged version. However, in order to minimize package size, some signals have been deleted or combined. These differences are detailed in Table 1-1. In the 4 x 3 (FT) version, the fourth quad framer is not populated and thus all the signals to and from this fourth framer are absent and should be treated as no connects (NC). Table 2-1 lists all of the signals on the MCM and it also lists the absent signals for the 4 x 3.

The availability of both a 12-channel and a 16-channel version allow the maximum framer density with the lowest cost.

Note: Some revisions of this device may incorporate deviations from published specifications known as errata. Multiple revisions of any device may be simultaneously available through various sales channels. For information about device errata, click here: <http://www.maxim-ic.com/errata>.

Changes from Normal DS21Q44 Configuration

- 1) TSYSClk and RSYSClk are connected together.
- 2) These signals are not available:
RFSYnc/RLCLk/RLINK/RCHCLk/RMSYnc/RLoS/LOTc/TCHBLk/TLCLk/TLINK/TCHCLk

Figure 1-1. DS21FT44/DS21FF44 SCHEMATIC

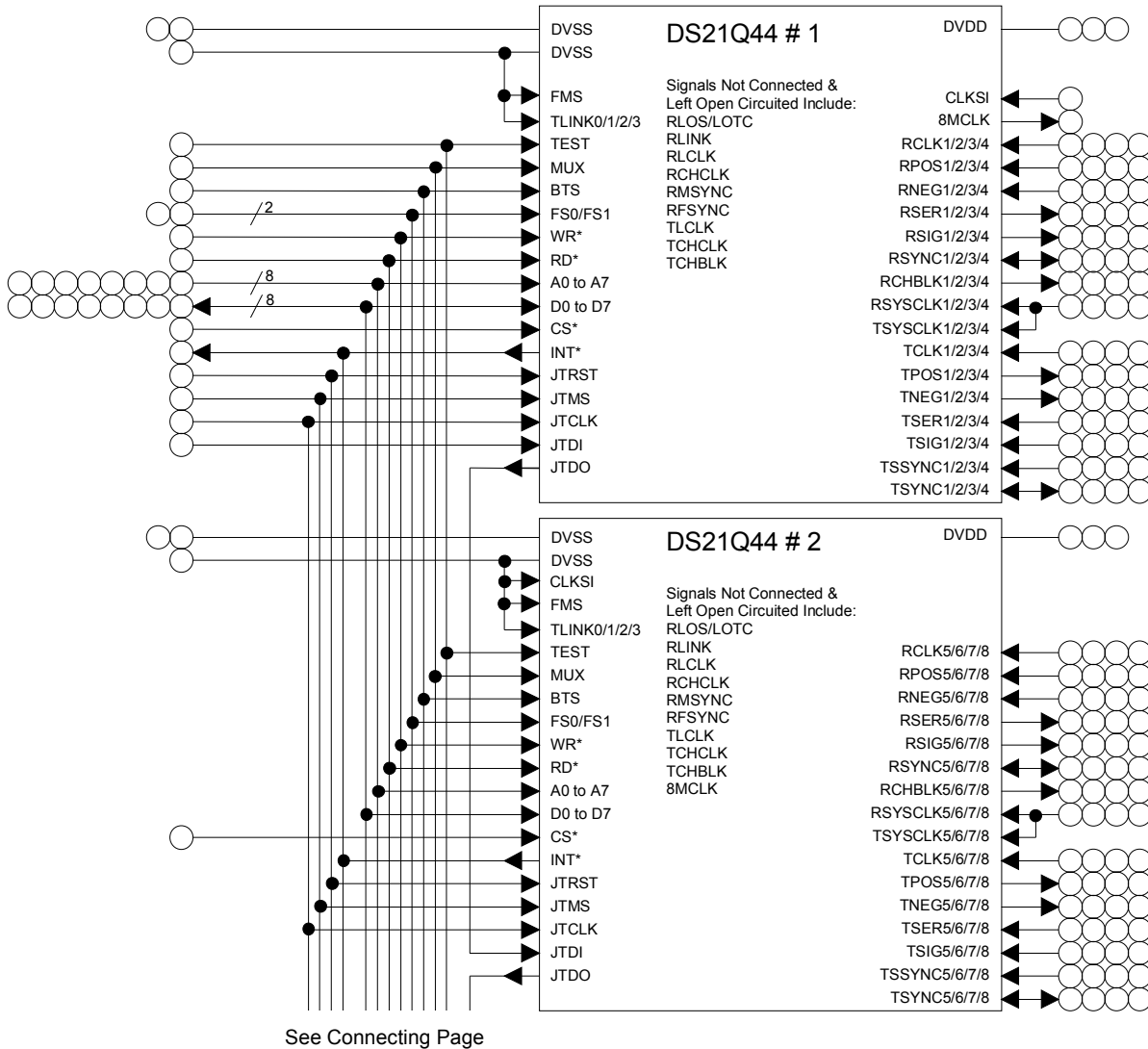

Figure 1-1. DS21FF44/DS21FT44 SCHEMATIC (continued)

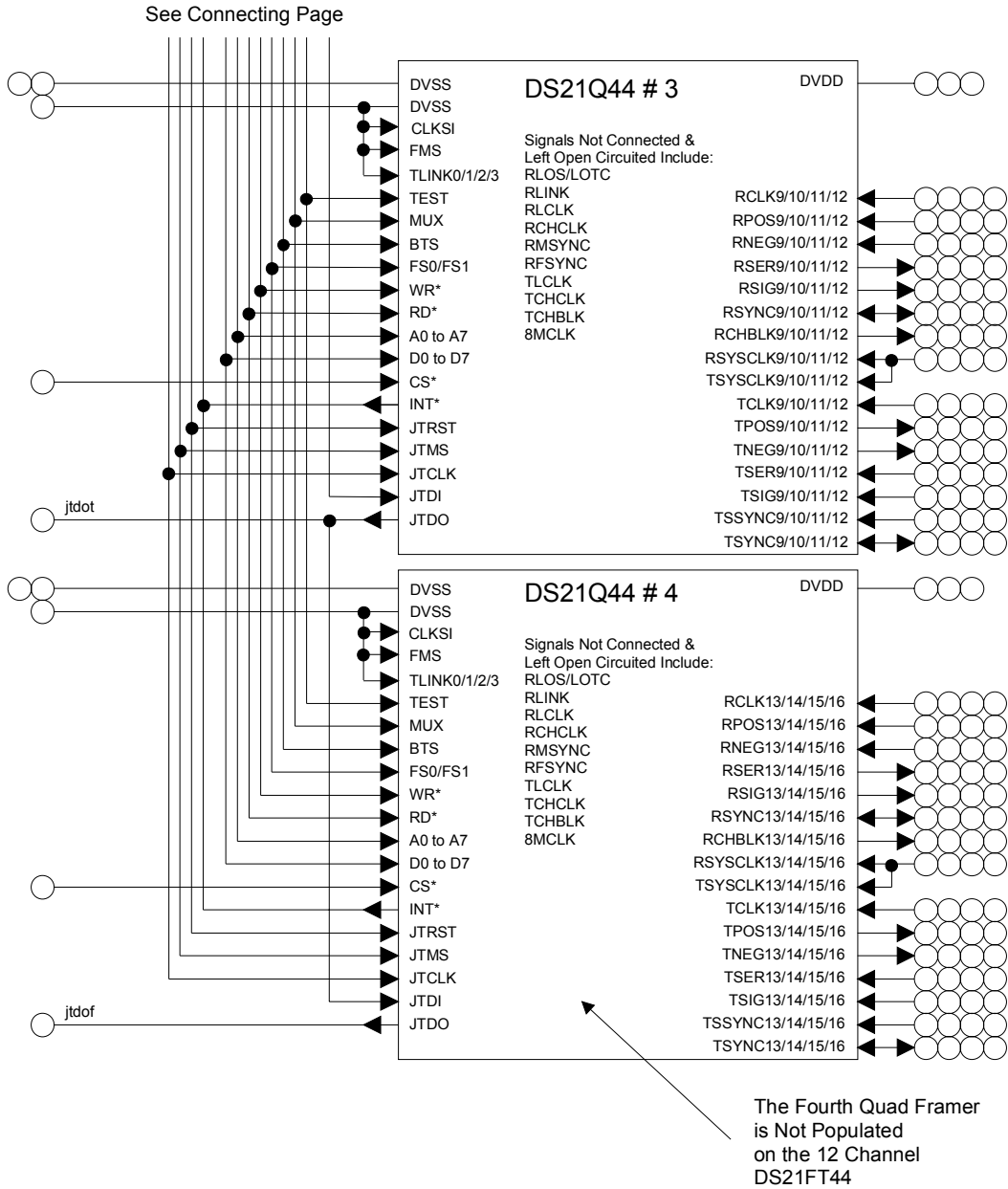

TABLE OF CONTENTS

1. DESCRIPTION.....	1
2. MCM PIN DESCRIPTION	7
3. DS21FF44 (4 x 4) PCB LAND PATTERNS	15
4. DS21FT44 (4 x 3) PCB Land Pattern	16
5. DS21Q42 DIE DESCRIPTION	17
6. DS21Q44 INTRODUCTION	18
7. DS21Q44 PIN FUNCTION DESCRIPTION	20
8. DS21Q44 REGISTER MAP	27
9. PARALLEL PORT	32
10. CONTROL, ID, AND TEST REGISTERS.....	32
11. STATUS AND INFORMATION REGISTERS	42
12. ERROR COUNT REGISTERS.....	50
13. DS0 MONITORING FUNCTION	53
14. SIGNALING OPERATION	56
14.1 PROCESSOR-BASED SIGNALING	56
14.2 HARDWARE-BASED SIGNALING	59
15. PER-CHANNEL CODE GENERATION AND LOOPBACK.....	60
15.1 TRANSMIT SIDE CODE GENERATION	60
15.1.1 <i>Simple Idle Code Insertion and Per-Channel Loopback</i>	60
15.1.2 <i>Per-Channel Code Insertion</i>	62
15.2 RECEIVE SIDE CODE GENERATION	62
16. CLOCK BLOCKING REGISTERS.....	63
17. ELASTIC STORES OPERATION.....	64
17.1 RECEIVE SIDE.....	65
17.2 TRANSMIT SIDE	65

18. ADDITIONAL (Sa) AND INTERNATIONAL (Si) BIT OPERATION	65
18.1 HARDWARE SCHEME	65
18.2 INTERNAL REGISTER SCHEME BASED ON DOUBLE-FRAME	66
18.3 INTERNAL REGISTER SCHEME BASED ON CRC4 MULTIFRAME.....	68
19. HDLC CONTROLLER FOR THE SA BITS OR DS0	70
19.1 GENERAL OVERVIEW	70
19.2 HDLC STATUS REGISTERS	71
19.3 BASIC OPERATION DETAILS	72
19.4 HDLC REGISTER DESCRIPTION	73
20. INTERLEAVED PCM BUS OPERATION.....	81
21. JTAG-BOUNDARY SCAN ARCHITECTURE AND TEST ACCESS PORT	84
21.1 DESCRIPTION	84
21.2 TAP CONTROLLER STATE MACHINE	85
21.3 INSTRUCTION REGISTER AND INSTRUCTIONS	87
21.4 TEST REGISTERS	89
22. TIMING DIAGRAMS.....	93
23. OPERATING PARAMETERS	103
24. MCM PACKAGE DIMENSIONS	116

DOCUMENT REVISION HISTORY

REVISION	NOTES
080798	Initial Release
122998	TEST and MUX pins were added at previous No Connect (NC) pins.
101899	DS21Q42 die specifications appended to data sheet.
020300	Conversion from Interleaf to Microsoft Word
120601	Updated DC Characteristics to show supply currents for DS21FT44/DS21FF44
062602	Updated device characterization data

2. MCM PIN DESCRIPTION

Table 2-1. PIN DESCRIPTION SORTED BY SYMBOL

PIN	SYMBOL	I/O	DESCRIPTION
B7	8MCLK	O	8.192 MHz Clock Based on CLKSI.
G20	A0	I	Address Bus Bit 0 (lsb).
H20	A1	I	Address Bus Bit 1.
G19	A2	I	Address Bus Bit 2.
H19	A3	I	Address Bus Bit 3.
G18	A4	I	Address Bus Bit 4.
H18	A5	I	Address Bus Bit 5.
G17	A6	I	Address Bus Bit 6.
H17	A7	I	Address Bus Bit 7 (msb).
W15	BTS	I	Bus Timing Select. 0 = Intel / 1 = Motorola.
B6	CLKSI	I	Reference clock for the 8.192MHz clock synthesizer.
T8	CS1*	I	Chip Select for Quad Framer 1.
Y4	CS2*	I	Chip Select for Quad Framer 2.
Y15	CS3*	I	Chip Select for Quad Framer 3.
E19	CS4*/NC	I	Chip Select for Quad Framer 4. NC on Four x Three.
L20	D0	I/O	Data Bus Bit 0 (lsb).
M20	D1	I/O	Data Bus Bit 1.
L19	D2	I/O	Data Bus Bit 2.
M19	D3	I/O	Data Bus Bit 3.
L18	D4	I/O	Data Bus Bit 4.
M18	D5	I/O	Data Bus Bit 5.
L17	D6	I/O	Data Bus Bit 6.
M17	D7	I/O	Data Bus Bit 7 (msb).
C7	DVDD1	—	Digital Positive Supply for Framer 1.
E4	DVDD1	—	Digital Positive Supply for Framer 1.
D2	DVDD1	—	Digital Positive Supply for Framer 1.
K3	DVDD2	—	Digital Positive Supply for Framer 2.
U7	DVDD2	—	Digital Positive Supply for Framer 2.
P2	DVDD2	—	Digital Positive Supply for Framer 2.
V19	DVDD3	—	Digital Positive Supply for Framer 3.
T12	DVDD3	—	Digital Positive Supply for Framer 3.
L16	DVDD3	—	Digital Positive Supply for Framer 3.
D17	DVDD4/NC	—	Digital Positive Supply for Framer 4. NC on Four x Three.
F16	DVDD4/NC	—	Digital Positive Supply for Framer 4. NC on Four x Three.
B11	DVDD4/NC	—	Digital Positive Supply for Framer 4. NC on Four x Three.
E9	DVSS1	—	Digital Signal Ground for Framer 1.
A6	DVSS1	—	Digital Signal Ground for Framer 1.
D5	DVSS1	—	Digital Signal Ground for Framer 1.
U3	DVSS2	—	Digital Signal Ground for Framer 2.
K4	DVSS2	—	Digital Signal Ground for Framer 2.

PIN	SYMBOL	I/O	DESCRIPTION
U8	DVSS2	—	Digital Signal Ground for Framer 2.
U4	DVSS3	—	Digital Signal Ground for Framer 3.
R16	DVSS3	—	Digital Signal Ground for Framer 3.
Y20	DVSS3	—	Digital Signal Ground for Framer 3.
J20	DVSS4/NC	—	Digital Signal Ground for Framer 4. NC on Four x Three.
A11	DVSS4/NC	—	Digital Signal Ground for Framer 4. NC on Four x Three.
D19	DVSS4/NC	—	Digital Signal Ground for Framer 4. NC on Four x Three.
Y14	FS0	I	Framer Select 0 for the Parallel Control Port.
W14	FS1	I	Framer Select 1 for the Parallel Control Port.
G16	INT*	O	Interrupt for all four Quad Framers.
V14	JTCLK	I	JTAG Clock.
E10	JTDI	I	JTAG Data Input.
A19	JTDOF/NC	O	JTAG Data Output for Four x Four Version. NC on Four x Three.
T17	JTDOT	O	JTAG Data Output for Four x Three Version.
H16	JTMS	I	JTAG Test Mode Select.
K17	JTRST*	I	JTAG Reset.
A13	TEST	I	Tri-State. 0 = do not tri-state / 1 = tri-state all outputs & I/O signals
P17	MUX	I	Bus Operation Select. 0 = nonmultiplexed bus / 1 = multiplexed bus
C2	RCHBLK1	O	Receive Channel Blocking Clock.
G3	RCHBLK2	O	Receive Channel Blocking Clock.
E6	RCHBLK3	O	Receive Channel Blocking Clock.
A8	RCHBLK4	O	Receive Channel Blocking Clock.
N1	RCHBLK5	O	Receive Channel Blocking Clock.
Y1	RCHBLK6	O	Receive Channel Blocking Clock.
U6	RCHBLK7	O	Receive Channel Blocking Clock.
N5	RCHBLK8	O	Receive Channel Blocking Clock.
Y8	RCHBLK9	O	Receive Channel Blocking Clock.
W12	RCHBLK10	O	Receive Channel Blocking Clock.
V17	RCHBLK11	O	Receive Channel Blocking Clock.
U17	RCHBLK12	O	Receive Channel Blocking Clock.
D16	RCHBLK13/NC	O	Receive Channel Blocking Clock. NC on Four x Three.
K20	RCHBLK14/NC	O	Receive Channel Blocking Clock. NC on Four x Three.
B18	RCHBLK15/NC	O	Receive Channel Blocking Clock. NC on Four x Three.
B16	RCHBLK16/NC	O	Receive Channel Blocking Clock. NC on Four x Three.
A2	RCLK1	I	Receive Clock for Framer 1
K1	RCLK2	I	Receive Clock for Framer 2.
D10	RCLK3	I	Receive Clock for Framer 3.
B9	RCLK4	I	Receive Clock for Framer 4.
M3	RCLK5	I	Receive Clock for Framer 5.
V1	RCLK6	I	Receive Clock for Framer 6.
W6	RCLK7	I	Receive Clock for Framer 7.
J3	RCLK8	I	Receive Clock for Framer 8.
T9	RCLK9	I	Receive Clock for Framer 9.

PIN	SYMBOL	I/O	DESCRIPTION
W10	RCLK10	I	Receive Clock for Framer 10.
Y18	RCLK11	I	Receive Clock for Framer 11.
N17	RCLK12	I	Receive Clock for Framer 12.
D14	RCLK13/NC	I	Receive Clock for Framer 13. NC on Four x Three.
P20	RCLK14/NC	I	Receive Clock for Framer 14. NC on Four x Three.
C18	RCLK15/NC	I	Receive Clock for Framer 15. NC on Four x Three.
C12	RCLK16/NC	I	Receive Clock for Framer 16. NC on Four x Three.
E18	RD*	I	Read Input.
B2	RNEG1	I	Receive Negative Data for Framer 1.
H2	RNEG2	I	Receive Negative Data for Framer 2.
D9	RNEG3	I	Receive Negative Data for Framer 3.
A9	RNEG4	I	Receive Negative Data for Framer 4.
M2	RNEG5	I	Receive Negative Data for Framer 5.
V3	RNEG6	I	Receive Negative Data for Framer 6.
V7	RNEG7	I	Receive Negative Data for Framer 7.
P3	RNEG8	I	Receive Negative Data for Framer 8.
U9	RNEG9	I	Receive Negative Data for Framer 9.
W11	RNEG10	I	Receive Negative Data for Framer 10.
W17	RNEG11	I	Receive Negative Data for Framer 11.
T20	RNEG12	I	Receive Negative Data for Framer 12.
E14	RNEG13/NC	I	Receive Negative Data for Framer 13. NC on Four x Three.
N20	RNEG14/NC	I	Receive Negative Data for Framer 14. NC on Four x Three.
C20	RNEG15/NC	I	Receive Negative Data for Framer 15. NC on Four x Three.
B13	RNEG16/NC	I	Receive Negative Data for Framer 16. NC on Four x Three.
A1	RPOS1	I	Receive Positive Data for Framer 1.
H1	RPOS2	I	Receive Positive Data for Framer 2.
H4	RPOS3	I	Receive Positive Data for Framer 3.
C9	RPOS4	I	Receive Positive Data for Framer 4.
M1	RPOS5	I	Receive Positive Data for Framer 5.
W2	RPOS6	I	Receive Positive Data for Framer 6.
V5	RPOS7	I	Receive Positive Data for Framer 7.
P4	RPOS8	I	Receive Positive Data for Framer 8.
T10	RPOS9	I	Receive Positive Data for Framer 9.
V11	RPOS10	I	Receive Positive Data for Framer 10.
Y19	RPOS11	I	Receive Positive Data for Framer 11.
R19	RPOS12	I	Receive Positive Data for Framer 12.
D15	RPOS13/NC	I	Receive Positive Data for Framer 13. NC on Four x Three.
J18	RPOS14/NC	I	Receive Positive Data for Framer 14. NC on Four x Three.
A20	RPOS15/NC	I	Receive Positive Data for Framer 15. NC on Four x Three.

PIN	SYMBOL	I/O	DESCRIPTION
A14	RPOS16/NC	I	Receive Positive Data for Framer 16. NC on Four x Three.
C1	RSER1	O	Receive Serial Data from Framer 1.
H3	RSER2	O	Receive Serial Data from Framer 2.
C6	RSER3	O	Receive Serial Data from Framer 3.
C8	RSER4	O	Receive Serial Data from Framer 4.
P1	RSER5	O	Receive Serial Data from Framer 5.
W4	RSER6	O	Receive Serial Data from Framer 6.
T7	RSER7	O	Receive Serial Data from Framer 7.
N4	RSER8	O	Receive Serial Data from Framer 8.
U11	RSER9	O	Receive Serial Data from Framer 9.
Y12	RSER10	O	Receive Serial Data from Framer 10.
V16	RSER11	O	Receive Serial Data from Framer 11.
T16	RSER12	O	Receive Serial Data from Framer 12.
E16	RSER13/NC	O	Receive Serial Data from Framer 13. NC on Four x Three.
F20	RSER14/NC	O	Receive Serial Data from Framer 14. NC on Four x Three.
C16	RSER15/NC	O	Receive Serial Data from Framer 15. NC on Four x Three.
A12	RSER16/NC	O	Receive Serial Data from Framer 16. NC on Four x Three.
D3	RSIG1	O	Receive Signaling Output from Framer 1.
G2	RSIG2	O	Receive Signaling Output from Framer 2.
D4	RSIG3	O	Receive Signaling Output from Framer 3.
D8	RSIG4	O	Receive Signaling Output from Framer 4.
N2	RSIG5	O	Receive Signaling Output from Framer 5.
V4	RSIG6	O	Receive Signaling Output from Framer 6.
V6	RSIG7	O	Receive Signaling Output from Framer 7.
K5	RSIG8	O	Receive Signaling Output from Framer 8.
U10	RSIG9	O	Receive Signaling Output from Framer 9.
Y11	RSIG10	O	Receive Signaling Output from Framer 10.
W19	RSIG11	O	Receive Signaling Output from Framer 11.
U20	RSIG12	O	Receive Signaling Output from Framer 12.
E15	RSIG13/NC	O	Receive Signaling Output from Framer 13. NC on Four x Three.
K19	RSIG14/NC	O	Receive Signaling Output from Framer 14. NC on Four x Three.
C17	RSIG15/NC	O	Receive Signaling Output from Framer 15. NC on Four x Three.
A15	RSIG16/NC	O	Receive Signaling Output from Framer 16. NC on Four x Three.
B1	RSYNC1	I/O	Receive Frame/Multiframe Sync for Framer 1.
G1	RSYNC2	I/O	Receive Frame/Multiframe Sync for Framer 2.
D6	RSYNC3	I/O	Receive Frame/Multiframe Sync for Framer 3.
A7	RSYNC4	I/O	Receive Frame/Multiframe Sync for Framer 4.
N3	RSYNC5	I/O	Receive Frame/Multiframe Sync for Framer 5.
Y2	RSYNC6	I/O	Receive Frame/Multiframe Sync for Framer 6.

PIN	SYMBOL	I/O	DESCRIPTION
U5	RSYNC7	I/O	Receive Frame/Multiframe Sync for Framer 7.
J4	RSYNC8	I/O	Receive Frame/Multiframe Sync for Framer 8.
T11	RSYNC9	I/O	Receive Frame/Multiframe Sync for Framer 9.
V13	RSYNC10	I/O	Receive Frame/Multiframe Sync for Framer 10.
V15	RSYNC11	I/O	Receive Frame/Multiframe Sync for Framer 11.
P18	RSYNC12	I/O	Receive Frame/Multiframe Sync for Framer 12.
J17	RSYNC13/NC	I/O	Receive Frame/Multiframe Sync for Framer 13. NC on Four x Three.
J19	RSYNC14/NC	I/O	Receive Frame/Multiframe Sync for Framer 14. NC on Four x Three.
B17	RSYNC15/NC	I/O	Receive Frame/Multiframe Sync for Framer 15. NC on Four x Three.
B12	RSYNC16/NC	I/O	Receive Frame/Multiframe Sync for Framer 16. NC on Four x Three.
B5	SYSCLK1	I	System Clock for Framer 1.
E2	SYSCLK2	I	System Clock for Framer 2.
E5	SYSCLK3	I	System Clock for Framer 3.
B8	SYSCLK4	I	System Clock for Framer 4.
M4	SYSCLK5	I	System Clock for Framer 5.
T2	SYSCLK6	I	System Clock for Framer 6.
Y5	SYSCLK7	I	System Clock for Framer 7.
W3	SYSCLK8	I	System Clock for Framer 8.
T4	SYSCLK9	I	System Clock for Framer 9.
Y9	SYSCLK10	I	System Clock for Framer 10.
U12	SYSCLK11	I	System Clock for Framer 11.
R17	SYSCLK12	I	System Clock for Framer 12.
E13	SYSCLK13/NC	I	System Clock for Framer 13. NC on Four x Three.
N18	SYSCLK14/NC	I	System Clock for Framer 14. NC on Four x Three.
E20	SYSCLK15/NC	I	System Clock for Framer 15. NC on Four x Three.
C14	SYSCLK16/NC	I	System Clock for Framer 16. NC on Four x Three.
D1	TCLK1	I	Transmit Clock for Framer 1.
H5	TCLK2	I	Transmit Clock for Framer 2.
C5	TCLK3	I	Transmit Clock for Framer 3.
A5	TCLK4	I	Transmit Clock for Framer 4.
R1	TCLK5	I	Transmit Clock for Framer 5.
Y3	TCLK6	I	Transmit Clock for Framer 6.
T6	TCLK7	I	Transmit Clock for Framer 7.
K2	TCLK8	I	Transmit Clock for Framer 8.
U13	TCLK9	I	Transmit Clock for Framer 9.
Y13	TCLK10	I	Transmit Clock for Framer 10.
T18	TCLK11	I	Transmit Clock for Framer 11.
P16	TCLK12	I	Transmit Clock for Framer 12.
K16	TCLK13/NC	I	Transmit Clock for Framer 13. NC on Four x Three.
F19	TCLK14/NC	I	Transmit Clock for Framer 14. NC on Four x Three.
E17	TCLK15/NC	I	Transmit Clock for Framer 15. NC on Four x Three.
C11	TCLK16/NC	I	Transmit Clock for Framer 16. NC on Four x Three.

PIN	SYMBOL	I/O	DESCRIPTION
C3	TNEG1	O	Transmit Negative Data from Framer 1.
J1	TNEG2	O	Transmit Negative Data from Framer 2.
F5	TNEG3	O	Transmit Negative Data from Framer 3.
A10	TNEG4	O	Transmit Negative Data from Framer 4.
L1	TNEG5	O	Transmit Negative Data from Framer 5.
V2	TNEG6	O	Transmit Negative Data from Framer 6.
V8	TNEG7	O	Transmit Negative Data from Framer 7.
P5	TNEG8	O	Transmit Negative Data from Framer 8.
U14	TNEG9	O	Transmit Negative Data from Framer 9.
V12	TNEG10	O	Transmit Negative Data from Framer 10.
W18	TNEG11	O	Transmit Negative Data from Framer 11.
T19	TNEG12	O	Transmit Negative Data from Framer 12.
D11	TNEG13/NC	O	Transmit Negative Data from Framer 13. NC on Four x Three.
K18	TNEG14/NC	O	Transmit Negative Data from Framer 14. NC on Four x Three.
C19	TNEG15/NC	O	Transmit Negative Data from Framer 15. NC on Four x Three.
B15	TNEG16/NC	O	Transmit Negative Data from Framer 16. NC on Four x Three.
B3	TPOS1	O	Transmit Positive Data from Framer 1.
J2	TPOS2	O	Transmit Positive Data from Framer 2.
J5	TPOS3	O	Transmit Positive Data from Framer 3.
B10	TPOS4	O	Transmit Positive Data from Framer 4.
L2	TPOS5	O	Transmit Positive Data from Framer 5.
W1	TPOS6	O	Transmit Positive Data from Framer 6.
W7	TPOS7	O	Transmit Positive Data from Framer 7.
R3	TPOS8	O	Transmit Positive Data from Framer 8.
T14	TPOS9	O	Transmit Positive Data from Framer 9.
Y10	TPOS10	O	Transmit Positive Data from Framer 10.
V18	TPOS11	O	Transmit Positive Data from Framer 11.
V20	TPOS12	O	Transmit Positive Data from Framer 12.
E12	TPOS13/NC	O	Transmit Positive Data from Framer 13. NC on Four x Three.
N19	TPOS14/NC	O	Transmit Positive Data from Framer 14. NC on Four x Three.
B19	TPOS15/NC	O	Transmit Positive Data from Framer 15. NC on Four x Three.
B14	TPOS16/NC	O	Transmit Positive Data from Framer 16. NC on Four x Three.
B4	TSER1	I	Transmit Serial Data for Framer 1.
E1	TSER2	I	Transmit Serial Data for Framer 2.
F3	TSER3	I	Transmit Serial Data for Framer 3.
D7	TSER4	I	Transmit Serial Data for Framer 4.
L5	TSER5	I	Transmit Serial Data for Framer 5.
T1	TSER6	I	Transmit Serial Data for Framer 6.
Y6	TSER7	I	Transmit Serial Data for Framer 7.

PIN	SYMBOL	I/O	DESCRIPTION
T3	TSER8	I	Transmit Serial Data for Framer 8.
M16	TSER9	I	Transmit Serial Data for Framer 9.
W9	TSER10	I	Transmit Serial Data for Framer 10.
W16	TSER11	I	Transmit Serial Data for Framer 11.
W20	TSER12	I	Transmit Serial Data for Framer 12.
D13	TSER13/NC	I	Transmit Serial Data for Framer 13. NC on Four x Three.
F17	TSER14/NC	I	Transmit Serial Data for Framer 14. NC on Four x Three.
D18	TSER15/NC	I	Transmit Serial Data for Framer 15. NC on Four x Three.
A18	TSER16/NC	I	Transmit Serial Data for Framer 16. NC on Four x Three.
C4	TSIG1	I	Transmit Signaling Input for Framer 1.
F1	TSIG2	I	Transmit Signaling Input for Framer 2.
G4	TSIG3	I	Transmit Signaling Input for Framer 3.
C10	TSIG4	I	Transmit Signaling Input for Framer 4.
L3	TSIG5	I	Transmit Signaling Input for Framer 5.
U2	TSIG6	I	Transmit Signaling Input for Framer 6.
V9	TSIG7	I	Transmit Signaling Input for Framer 7.
R5	TSIG8	I	Transmit Signaling Input for Framer 8.
U15	TSIG9	I	Transmit Signaling Input for Framer 9.
V10	TSIG10	I	Transmit Signaling Input for Framer 10.
U18	TSIG11	I	Transmit Signaling Input for Framer 11.
R18	TSIG12	I	Transmit Signaling Input for Framer 12.
E11	TSIG13/NC	I	Transmit Signaling Input for Framer 13. NC on Four x Three.
P19	TSIG14/NC	I	Transmit Signaling Input for Framer 14. NC on Four x Three.
B20	TSIG15/NC	I	Transmit Signaling Input for Framer 15. NC on Four x Three.
A16	TSIG16/NC	I	Transmit Signaling Input for Framer 16. NC on Four x Three.
A3	TSSYNC1	I	Transmit System Sync for Framer 1.
F2	TSSYNC2	I	Transmit System Sync for Framer 2.
G5	TSSYNC3	I	Transmit System Sync for Framer 3.
E8	TSSYNC4	I	Transmit System Sync for Framer 4.
L4	TSSYNC5	I	Transmit System Sync for Framer 5.
U1	TSSYNC6	I	Transmit System Sync for Framer 6.
Y7	TSSYNC7	I	Transmit System Sync for Framer 7.
R4	TSSYNC8	I	Transmit System Sync for Framer 8.
T15	TSSYNC9	I	Transmit System Sync for Framer 9.
W8	TSSYNC10	I	Transmit System Sync for Framer 10.
Y17	TSSYNC11	I	Transmit System Sync for Framer 11.
U19	TSSYNC12	I	Transmit System Sync for Framer 12.
C13	TSSYNC13/NC	I	Transmit System Sync for Framer 13. NC on Four x Three.
R20	TSSYNC14/NC	I	Transmit System Sync for Framer 14. NC on Four x Three.
D20	TSSYNC15/NC	I	Transmit System Sync for Framer 15. NC on Four x Three.

PIN	SYMBOL	I/O	DESCRIPTION
A17	TSSYNC16/NC	I	Transmit System Sync for Framer 16. NC on Four x Three.
E3	TSYNC1	I/O	Transmit Sync for Framer 1.
F4	TSYNC2	I/O	Transmit Sync for Framer 2.
E7	TSYNC3	I/O	Transmit Sync for Framer 3.
A4	TSYNC4	I/O	Transmit Sync for Framer 4.
R2	TSYNC5	I/O	Transmit Sync for Framer 5.
W5	TSYNC6	I/O	Transmit Sync for Framer 6.
T5	TSYNC7	I/O	Transmit Sync for Framer 7.
M5	TSYNC8	I/O	Transmit Sync for Framer 8.
T13	TSYNC9	I/O	Transmit Sync for Framer 9.
W13	TSYNC10	I/O	Transmit Sync for Framer 10.
U16	TSYNC11	I/O	Transmit Sync for Framer 11.
N16	TSYNC12	I/O	Transmit Sync for Framer 12.
J16	TSYNC13/NC	I/O	Transmit Sync for Framer 13. NC on Four x Three.
F18	TSYNC14/NC	I/O	Transmit Sync for Framer 14. NC on Four x Three.
C15	TSYNC15/NC	I/O	Transmit Sync for Framer 15. NC on Four x Three.
D12	TSYNC16/NC	I/O	Transmit Sync for Framer 16. NC on Four x Three.
Y16	WR*	I	Write Input.

3. DS21FF44 (4 X 4) PCB LAND PATTERNS

The diagram shown below is the pin pattern that is placed on the target PCB. This is the same pattern that would be seen as viewed through the MCM from the top.

Figure 3-1. PIN PATTERN FOR TARGET PCB (4 X 4)

	1	2	3	4	5	6	7	8	9	10	11	12	13	14	15	16	17	18	19	20
A	rpos 1	rclk 1	ts sync1	tsync 4	talk 4	dvss 1	rsync 4	rch blk 4	rneg 4	tneg 4	dvss 4	rser 16	test	rpos 16	rsig 16	tsig 16	ts sync 16	tser 16	jtdof	rpos 15
B	rsync 1	meg 1	tpos 1	tser 1	sys clk 1	clk 1	8 mclk	sys clk 4	rcik 4	tpos 4	dvdd 4	rsync 16	rneg 16	tpos 16	tneg 16	rch blk 16	rsync 15	rch blk 15	tpos 15	tsig 15
C	rser 1	rch blk 1	tneg 1	tsig 1	talk 3	rser 3	dvdd 1	rser4	rpos 4	tsig 4	talk 16	rcik 16	ts sync 13	sys clk 16	tsync 15	rser 15	rsig 15	rcik 15	tneg 15	rneg 15
D	talk 1	dvdd 1	rsig 1	rsig 3	dvss 1	rsync 3	tser 4	rsig4	rneg 3	rcik 3	tneg 13	tsync 16	tser 13	rcik 13	rpos 13	rch blk 13	dvdd 4	tser 15	dvss 4	ts sync 15
E	tser 2	sys clk 2	tsync 1	dvdd 1	sys clk 3	rch blk 3	tsync 3	ts sync 4	dvss 1	jtdi	tsig 13	tpos 13	sys clk 13	meg 13	rsig 13	rser 13	talk 15	rd*	cs4*	sys clk 15
F	tsig 2	ts sync 2	tser 3	tsync 2	tneg 3											dvdd 4	tser 14	tsync 14	talk 14	rser 14
G	rsync 2	rsig 2	rch blk 2	tsig 3	ts sync 3											int*	A6	A4	A2	A0
H	rpos 2	meg 2	rser 2	rpos 3	talk 2											jims	A7	A5	A3	A1
J	tneg 2	tpos 2	rcik 8	rsync 8	tpos 3											tsync 13	rsync 13	rpos 14	rsync 14	dvss 4
K	rcik 2	talk 8	dvdd 2	dvss 2	rsig 8											talk 13	jtrst*	tneg 14	rsig 14	rch blk 14
L	tneg 5	tpos 5	tsig 5	ts sync 5	tser 5											dvdd 3	D6	D4	D2	D0
M	rpos 5	meg 5	rcik 5	sys clk 5	tsync 8											tser 9	D7	D5	D3	D1
N	rch blk 5	rsig 5	rsync 5	rser 8	rch blk 8											tsync 12	rcik 12	sys clk 14	tpos 14	rneg 14
P	rser 5	dvdd 2	meg 8	rpos 8	tneg 8											talk 12	mux	rsync 12	tsig 14	rcik 14
R	talk 5	tsync 5	tpos 8	ts sync 8	tsig 8											dvss 3	sys clk 12	tsig 12	rpos 12	ts sync 14
T	tser 6	sys clk 6	tser 8	sys clk 9	tsync 7	talk 7	rser 7	cs1*	rcik 9	rpos 9	rsync 9	dvdd 3	tsync 9	tpos 9	ts sync 9	rser 12	jtdot	talk 11	tneg 12	rneg 12
U	ts sync 6	tsig 6	dvss 2	dvss 3	rsync 7	rch blk 7	dvdd 2	dvss 2	meg 9	rsig 9	rser 9	sys clk 11	talk 9	tneg 9	tsig 9	tsync 11	rch blk 12	tsig 11	tssync 12	rsig 12
V	rcik 6	tneg 6	meg 6	rsig 6	rpos 7	rsig 7	rneg 7	tneg 7	tsig 7	tsig 10	rpos 10	tneg 10	rsync 10	jtalk	rsync 11	rser 11	rch blk 11	tpos 11	dvdd 3	tpos 12
W	tpos 6	rpos 6	sys clk 8	rser 6	tsync 6	rcik 7	tpos 7	ts sync 10	tser 10	rcik 10	meg 10	rch blk 10	tsync 10	fs1	bts	tser 11	meg 11	tneg 11	rsig 11	tser 12
Y	rch blk 6	rsync 6	talk 6	cs2*	sys clk 7	tser 7	ts sync 7	rch blk 9	sys clk 10	tpos 10	rsig 10	rser 10	talk 10	fs0	cs3*	wr*	ts sync 11	rcik 11	rpos 11	dvss 3

4. DS21FT44 (Four x Three) PCB Land Pattern

The diagram shown below is the pin pattern that is placed on the target PCB. This is the same pattern that would be seen as viewed through the MCM from the top.

Figure 4-1. PIN PATTERN FOR TARGET PCB (4 X 3)

	1	2	3	4	5	6	7	8	9	10	11	12	13	14	15	16	17	18	19	20
A	rpos 1	rclk 1	ts sync1	tsync 4	talk 4	dvss 1	rsync 4	rch blk 4	mreg 4	tneg 4	nc	nc	test	ns	ns	nc	nc	nc	nc	nc
B	rsync 1	mreg 1	tpos 1	tser 1	sys clk 1	clkst	8 mclk	sys clk 4	rclk 4	tpos 4	nc	nc	nc	nc	nc	nc	nc	nc	nc	nc
C	rser 1	rch blk 1	tneg 1	tsig 1	talk 3	rser 3	dvdd 1	rser4	rpos 4	tsig 4	nc	nc	nc	nc	ns	nc	nc	nc	nc	nc
D	talk 1	dvdd 1	rsig 1	rsig 3	dvss 1	rsync 3	tser 4	rsig4	mreg 3	rclk 3	nc	nc	nc	nc	nc	nc	nc	nc	nc	nc
E	tser 2	sys clk 2	tsync 1	dvdd 1	sys clk 3	rch blk 3	tsync 3	ts sync 4	dvss 1	jtdi	nc	nc	nc	nc	nc	nc	nc	rd*	nc	nc
F	tsig 2	ts sync 2	tser 3	tsync 2	tneg 3											nc	nc	nc	nc	nc
G	rsync 2	rsig 2	rch blk 2	tsig 3	ts sync 3											int*	A6	A4	A2	A0
H	rpos 2	mreg 2	rser 2	rpos 3	talk 2											jtms	A7	A5	A3	A1
J	tneg 2	tpos 2	rclk 8	rsync 8	tpos 3											nc	nc	nc	nc	nc
K	rclk 2	talk 8	dvdd 2	dvss 2	rsig 8											nc	jtstr*	nc	nc	nc
L	tneg 5	tpos 5	tsig 5	ts sync 5	tser 5											dvdd 3	D6	D4	D2	D0
M	rpos 5	mreg 5	rclk 5	sys clk 5	tsync 8											tser 9	D7	D5	D3	D1
N	rch blk 5	rsig 5	rsync 5	rser 8	rch blk 8											tsync 12	rclk 12	nc	nc	nc
P	rser 5	dvdd 2	mreg 8	rpos 8	tneg 8											talk 12	mux	rsync 12	nc	nc
R	talk 5	tsync 5	tpos 8	ts sync 8	tsig 8											dvss 3	sys clk 12	tsig 12	rpos 12	nc
T	tser 6	sys clk 6	tser 8	sys clk 9	tsync 7	talk 7	rser 7	cs1*	rclk 9	rpos 9	rsync 9	dvdd 3	tsync 9	tpos 9	ts sync 9	rser 12	jtdot	talk 11	tneg 12	mreg 12
U	ts sync 6	tsig 6	dvss 2	dvss 3	rsync 7	rch blk 7	dvdd 2	dvss 2	mreg 9	rsig 9	rser 9	sys clk 11	talk 9	tneg 9	tsig 9	tsync 11	rch blk 12	tsig 11	tssync 12	rsig 12
V	rclk 6	tneg 6	mreg 6	rsig 6	rpos 7	rsig 7	mreg 7	tneg 7	tsig 7	tsig 10	rpos 10	tneg 10	rsync 10	jtclk	rsync 11	rser 11	rch blk 11	tpos 11	dvdd 3	tpos 12
W	tpos 6	rpos 6	sys clk 8	rser 6	tsync 6	rclk 7	tpos 7	ts sync 10	tser 10	rclk 10	mreg 10	rch blk 10	tsync 10	fs1	bts	tser 11	mreg 11	tneg 11	rsig 11	tser 12
Y	rch blk 6	rsync 6	talk 6	cs2*	sys clk 7	tser 7	ts sync 7	rch blk 9	sys clk 10	tpos 10	rsig 10	rser 10	talk 10	fs0	cs3*	wr*	ts sync 11	rclk 11	rpos 11	dvss 3

5. DS21Q44 DIE DESCRIPTION

FEATURES

- Four E1 (CEPT or PCM-30)/ISDN-PRI framing transceivers
- All four framers are fully independent; transmit and receive sections of each framer are fully independent
- Frames to FAS, CAS, CCS, and CRC4 formats
- Each of the four framers contain dual two-frame elastic store slip buffers that can connect to asynchronous backplanes up to 8.192MHz
- 8-bit parallel control port that can be used directly on either multiplexed or nonmultiplexed buses (Intel or Motorola)
- Easy access to Si and Sa bits
- Extracts and inserts CAS signaling
- Large counters for bipolar and code violations, CRC4 code word errors, FAS word errors, and E-bits
- Programmable output clocks for Fractional E1, per channel loopback, H0 and H12 applications
- Integral HDLC controller with 64-byte buffers configurable for Sa bits or DS0 operation
- Detects and generates AIS, remote alarm, and remote multiframe alarms
- Pin compatible with DS21Q42 enhanced quad T1 framer
- 3.3V supply with 5V tolerant I/O; low-power CMOS
- Available in 128-pin TQFP package
- IEEE 1149.1 support

DESCRIPTION

The DS21Q44 E1 is an enhanced version of the DS21Q43 quad E1 framer. The DS21Q44 contains four framers that are configured and read through a common microprocessor-compatible parallel port. Each framer consists of a receive framer, receive elastic store, transmit formatter, and transmit elastic store. All four framers in the DS21Q44 are totally independent; they do not share a common framing synchronizer. The transmit and receive sides of each framer are also totally independent. The dual two-frame elastic stores contained in each of the four framers can be independently enabled and disabled as required.

The device fully meets all of the latest E1 specifications including CCITT/ITU G.704, G.706, G.962, and I.431 as well as ETS 300 011 and ETS 300 233.

FUNCTIONAL DIAGRAM

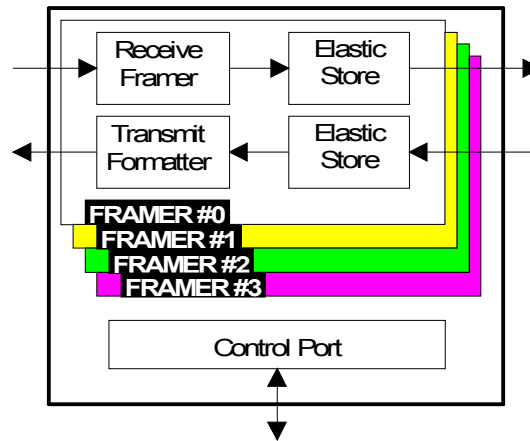

6. DS21Q44 INTRODUCTION

The DS21Q44 is a superset version of the popular DS21Q43 quad E1 framer offering the new features listed below. All of the original features of the DS21Q43 have been retained and software created for the original device is transferable to the DS21Q44.

NEW FEATURES

- Additional hardware signaling capability including:
 - receive signaling reinsertion to a backplane multiframe sync
 - availability of signaling in a separate PCM data stream
 - signaling freezing
 - interrupt generated on change of signaling data
- Per-channel code insertion in both transmit and receive paths
- Full HDLC controller with 64-byte buffers in both transmit and receive paths. Configurable for Sa bits or DS0 access
- RCL, RLOS, RRA, and RUA1 alarms now interrupt on change of state
- 8.192MHz clock synthesizer
- Ability to monitor one DS0 channel in both the transmit and receive paths
- Option to extend carrier loss criteria to a 1 ms period as per ETS 300 233
- Automatic RAI generation to ETS 300 011 specifications
- IEEE 1149.1 support

FUNCTIONAL DESCRIPTION

The receive side in each framer locates FAS frame and CRC and CAS multiframe boundaries as well as detects incoming alarms including, carrier loss, loss of synchronization, AIS and Remote Alarm. If needed, the receive side elastic store can be enabled in order to absorb the phase and frequency differences between the recovered E1 data stream and an asynchronous backplane clock, which is provided at the RSYCLK input. The clock applied at the RSYCLK input can be either a 2.048 MHz clock or a 1.544 MHz clock. The RSYCLK can be a burst clock with speeds up to 8.192 MHz.

The transmit side in each framer is totally independent from the receive side in both the clock requirements and characteristics. Data off of a backplane can be passed through a transmit side elastic store if necessary. The transmit formatter will provide the necessary frame/multiframe data overhead for E1 transmission.

READER'S NOTE:

This data sheet assumes a particular nomenclature of the E1 operating environment. In each 125 μ s frame, there are 32 8-bit timeslots numbered 0 to 31. Timeslot 0 is transmitted first and received first. These 32 timeslots are also referred to as channels with a numbering scheme of 1 to 32. Timeslot 0 is identical to channel 1, timeslot 1 is identical to Channel 2, and so on. Each timeslot (or channel) is made up of 8 bits, which are numbered 1 to 8. Bit number 1 is the MSB and is transmitted first. Bit number 8 is the LSB and is transmitted last. Throughout this data sheet, the following abbreviations are used:

FAS	Frame Alignment Signal	CRC4	Cyclical Redundancy Check
CAS	Channel Associated Signaling	CCS	Common Channel Signaling
MF	Multiframe	Sa	Additional bits
Si	International bits	E-bit	CRC4 Error Bits

Figure 6-1. DS21Q44 ENHANCED QUAD E1 FRAMER

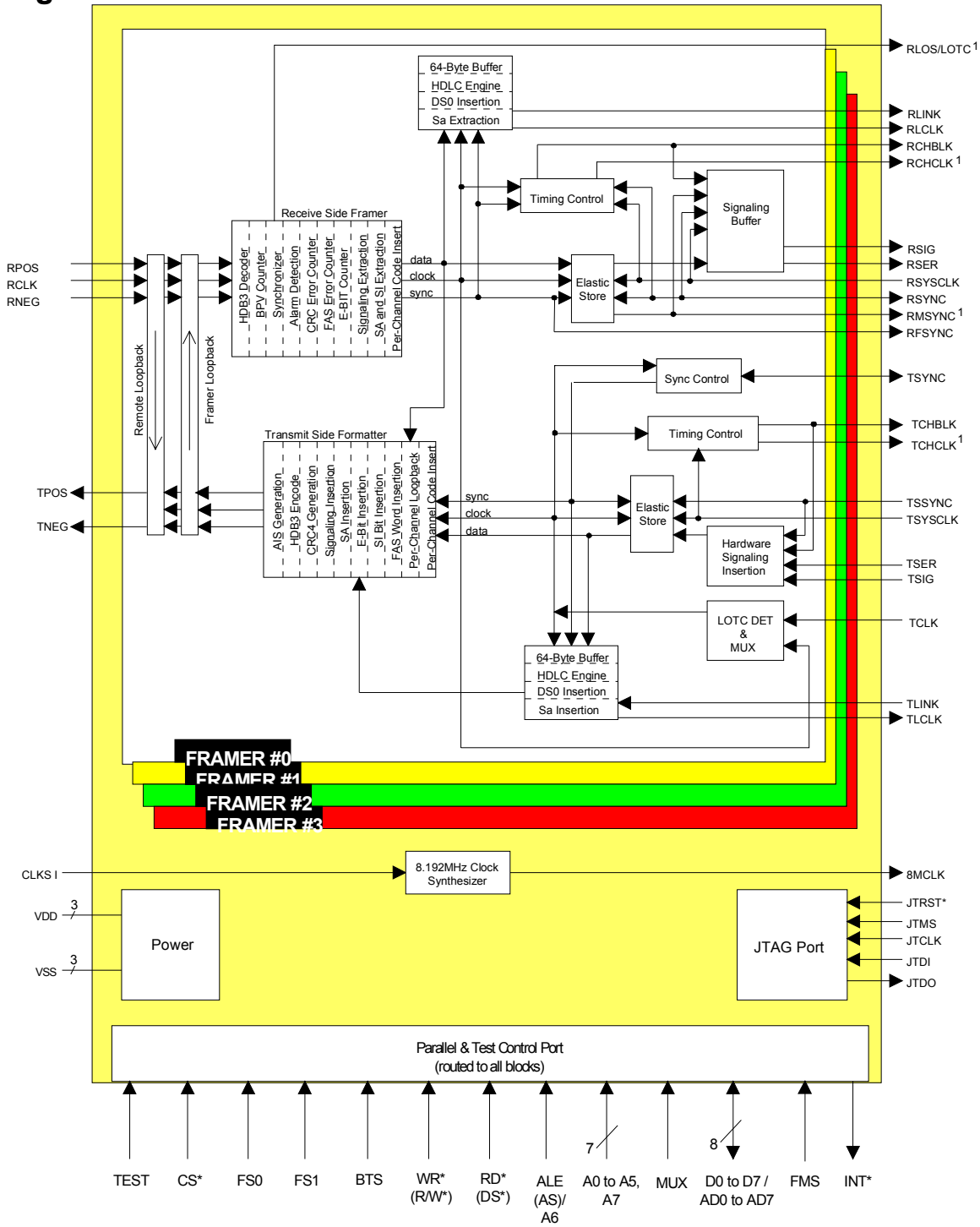

Note:
1. Alternate pin functions. Consult data sheet for restrictions.

7. DS21Q44 PIN FUNCTION DESCRIPTION

This section describes the signals on the DS21Q44 die. Signals that are not bonded out or have limited functionality in the DS21FT44 and DS21FF44 are noted in italics.

TRANSMIT SIDE PINS

Signal Name: **TCLK**

Signal Description: **Transmit Clock**

Signal Type: **Input**

A 2.048MHz primary clock. Used to clock data through the transmit side formatter.

Signal Name: **TSER**

Signal Description: **Transmit Serial Data**

Signal Type: **Input**

Transmit NRZ serial data. Sampled on the falling edge of TCLK when the transmit side elastic store is disabled. Sampled on the falling edge of TSYSClk when the transmit side elastic store is enabled.

Signal Name: **TCHCLK**

Signal Description: **Transmit Channel Clock**

Signal Type: **Output**

A 256kHz clock that pulses high during the LSB of each channel. Synchronous with TCLK when the transmit side elastic store is disabled. Synchronous with TSYSClk when the transmit side elastic store is enabled. Useful for parallel to serial conversion of channel data. This function is available when FMS = 1 (DS21Q43 emulation). *This signal is not bonded out in the DS21FF44/DS21FT44.*

Signal Name: **TCHBLK**

Signal Description: **Transmit Channel Block**

Signal Type: **Output**

A user-programmable output that can be forced high or low during any of the 32 E1 channels. Synchronous with TCLK when the transmit side elastic store is disabled. Synchronous with TSYSClk when the transmit side elastic store is enabled. Useful for blocking clocks to a serial UART or LAPD controller in applications where not all E1 channels are used such as Fractional E1, 384kbps (H0), 768kbps, 1920kbps (H12) or ISDN-PRI. Also useful for locating individual channels in drop-and-insert applications, for external per-channel loopback, and for per-channel conditioning. See Section 16 for details. *This signal is not bonded out in the DS21FF44/DS21FT44.*

Signal Name: **TSYSCLK**

Signal Description: **Transmit System Clock**

Signal Type: **Input**

1.544MHz or 2.048MHz clock. Only used when the transmit side elastic store function is enabled. Should be connected low in applications that do not use the transmit side elastic store. Can be burst at rates up to 8.192MHz. *This pin is connected to the RSYSClk signal in the DS21FF44/DS21FT44.*

Signal Name: **TLCLK**

Signal Description: **Transmit Link Clock**

Signal Type: **Output**

4kHz to 20kHz demand clock for the TLINK input. See Section 18 for details. *This signal is not bonded out in the DS21FF44/DS21FT44.*

Signal Name: **TLINK**
 Signal Description: **Transmit Link Data**
 Signal Type: **Input**

If enabled, this pin will be sampled on the falling edge of TCLK for data insertion into any combination of the Sa bit positions (Sa4 to Sa8). See Section 18 for details. *This signal is not bonded out in the DS21FF44/DS21FT44.*

Signal Name: **TSYNC**
 Signal Description: **Transmit Sync**
 Signal Type: **Input /Output**

A pulse at this pin will establish either frame or multiframe boundaries for the transmit side. This pin can also be programmed to output either a frame or multiframe pulse. Always synchronous with TCLK.

Signal Name: **TSSYNC**
 Signal Description: **Transmit System Sync**
 Signal Type: **Input**

Only used when the transmit side elastic store is enabled. A pulse at this pin will establish either frame or multiframe boundaries for the transmit side. Should be connected low in applications that do not use the transmit side elastic store. Always synchronous with TSYCLK.

Signal Name: **TSIG**
 Signal Description: **Transmit Signaling Input**
 Signal Type: **Input**

When enabled, this input will sample signaling bits for insertion into outgoing PCM E1 data stream. Sampled on the falling edge of TCLK when the transmit side elastic store is disabled. Sampled on the falling edge of TSYCLK when the transmit side elastic store is enabled. This function is available when FMS = 0. *FMS is connected to ground for the DS21FF44/DS21FT44.*

Signal Name: **TPOS**
 Signal Description: **Transmit Positive Data Output**
 Signal Type: **Output**

Updated on the rising edge of TCLK with the bipolar data out of the transmit side formatter. Can be programmed to source NRZ data by the Output Data Format (TCR1.7) control bit.

Signal Name: **TNEG**
 Signal Description: **Transmit Negative Data Output**
 Signal Type: **Output**

Updated on the rising edge of TCLK with the bipolar data out of the transmit side formatter.

RECEIVE SIDE PINS

Signal Name: **RLINK**
 Signal Description: **Receive Link Data**
 Signal Type: **Output**

Updated with full recovered E1 data stream on the rising edge of RCLK. *This signal is not bonded out in the DS21FF44/DS21FT44.*

Signal Name: **RLCLK**
 Signal Description: **Receive Link Clock**
 Signal Type: **Output**
 A 4kHz to 20kHz clock for the RLINK output. Used for sampling Sa bits. *This signal is not bonded out in the DS21FF44/DS21FT44.*

Signal Name: **RCLK**
 Signal Description: **Receive Clock Input**
 Signal Type: **Input**
 2.048MHz clock that is used to clock data through the receive side framer.

Signal Name: **RCHCLK**
 Signal Description: **Receive Channel Clock**
 Signal Type: **Output**
 A 256kHz clock that pulses high during the LSB of each channel. Synchronous with RCLK when the receive side elastic store is disabled. Synchronous with RSYCLK when the receive side elastic store is enabled. Useful for parallel to serial conversion of channel data. This function is available when FMS = 1 (DS21Q43 emulation). *This signal is not bonded out in the DS21FF44/DS21FT44.*

Signal Name: **RCHBLK**
 Signal Description: **Receive Channel Block**
 Signal Type: **Output**
 A user programmable output that can be forced high or low during any of the 32 E1 channels. Synchronous with RCLK when the receive side elastic store is disabled. Synchronous with RSYCLK when the receive side elastic store is enabled. Useful for blocking clocks to a serial UART or LAPD controller in applications where not all E1 channels are used such as Fractional E1, 384kbps service, 768kbps, or ISDN-PRI. Also useful for locating individual channels in drop-and-insert applications, for external per-channel loopback, and for per-channel conditioning. See Section 16 for details.

Signal Name: **RSER**
 Signal Description: **Receive Serial Data**
 Signal Type: **Output**
 Received NRZ serial data. Updated on rising edges of RCLK when the receive side elastic store is disabled. Updated on the rising edges of RSYCLK when the receive side elastic store is enabled.

Signal Name: **RSYNC**
 Signal Description: **Receive Sync**
 Signal Type: **Input /Output**
 An extracted pulse, one RCLK wide, is output at this pin, which identifies either frame or CAS/CRC multiframe boundaries. If the receive side elastic store is enabled, then this pin can be enabled to be an input at which a frame or multiframe boundary pulse synchronous with RSYCLK is applied.

Signal Name: **RFSYNC**
 Signal Description: **Receive Frame Sync**
 Signal Type: **Output**
 An extracted 8kHz pulse, one RCLK wide, is output at this pin, which identifies frame boundaries. *This signal is not bonded out in the DS21FF44/DS21FT44.*

Signal Name: **RMSYNC**
 Signal Description: **Receive Multiframe Sync**
 Signal Type: **Output**

An extracted pulse, one RSYCLK wide, is output at this pin, which identifies multiframe boundaries. If the receive side elastic store is disabled, then this output will output multiframe boundaries associated with RCLK. This function is available when FMS = 1 (DS21Q43 emulation). *This signal is not bonded out in the DS21FF44/DS21FT44.*

Signal Name: **RSYSCLK**
 Signal Description: **Receive System Clock**
 Signal Type: **Input**

1.544MHz or 2.048MHz clock. Only used when the elastic store function is enabled. Should be connected low in applications that do not use the elastic store. Can be burst at rates up to 8.192MHz. *This pin is connected to the TSYCLK signal in the DS21FF44/DS21FT44.*

Signal Name: **RSIG**
 Signal Description: **Receive Signaling Output**
 Signal Type: **Output**

Outputs signaling bits in a PCM format. Updated on rising edges of RCLK when the receive side elastic store is disabled. Updated on the rising edges of RSYCLK when the receive side elastic store is enabled. This function is available when FMS = 0. *FMS is connected to ground for the DS21FF44/DS21FT44.*

Signal Name: **RLOS/LOTC**
 Signal Description: **Receive Loss of Sync / Loss of Transmit Clock**
 Signal Type: **Output**

A dual function output that is controlled by the TCR2.0 control bit. This pin can be programmed to either toggle high when the synchronizer is searching for the frame and multiframe or to toggle high if the TCLK pin has not been toggled for 5 μ s. This function is available when FMS = 1 (DS21Q43 emulation). *This signal is not bonded out in the DS21FF44/DS21FT44.*

Signal Name: **CLKSI**
 Signal Description: **8MHz Clock Reference**
 Signal Type: **Input**

A 2.048MHz reference clock used in the generation of 8MCLK. This function is available when FMS = 0. *FMS is connected to ground for the DS21FF44/DS21FT44.*

Signal Name: **8MCLK**
 Signal Description: **8 MHz Clock**
 Signal Type: **Output**

An 8.192MHz output clock that is referenced to the clock that is input at the CLKSI pin. This function is available when FMS = 0. *FMS is connected to ground for the DS21FF44/DS21FT44.*

Signal Name: **RPOS**
 Signal Description: **Receive Positive Data Input**
 Signal Type: **Input**

Sampled on the falling edge of RCLK for data to be clocked through the receive side framer. RPOS and RNEG can be connected together for an NRZ interface. Connecting RPOS to RNEG disables the bipolar violation monitoring circuitry.

Signal Name: **RNEG**
 Signal Description: **Receive Negative Data Input**
 Signal Type: **Input**

Sampled on the falling edge of RCLK for data to be clocked through the receive side framer. RPOS and RNEG can be connected together for an NRZ interface. Connecting RPOS to RNEG disables the bipolar violation monitoring circuitry.

PARALLEL CONTROL PORT PINS

Signal Name: **INT***
 Signal Description: **Interrupt**
 Signal Type: **Output**

Flags host controller during conditions and change of conditions defined in the Status Registers 1 and 2 and the FDL Status Register. Active-low, open-drain output.

Signal Name: **FMS**
 Signal Description: **Framer Mode Select**
 Signal Type: **Input**

Set low to select DS21Q44 feature set. Set high to select DS21Q43 emulation. *FMS is connected to ground for the DS21FF44/DS21FT44.*

Signal Name: **MUX**
 Signal Description: **Bus Operation**
 Signal Type: **Input**

Set low to select nonmultiplexed bus operation. Set high to select multiplexed bus operation.

Signal Name: **D0 to D7 / AD0 to AD7**
 Signal Description: **Data Bus or Address/Data Bus**
 Signal Type: **Input /Output**

In nonmultiplexed bus operation (MUX = 0), serves as the data bus. In multiplexed bus operation (MUX = 1), serves as an 8-bit multiplexed address/data bus.

Signal Name: **A0 to A5, A7**
 Signal Description: **Address Bus**
 Signal Type: **Input**

In nonmultiplexed bus operation (MUX = 0), serves as the address bus. In multiplexed bus operation (MUX = 1), these pins are not used and should be connected low.

Signal Name: **ALE (AS) / A6**
 Signal Description: **Address Latch Enable (Address Strobe) or A6**
 Signal Type: **Input**

In nonmultiplexed bus operation (MUX = 0), serves as address bit 6. In multiplexed bus operation (MUX = 1), serves to demultiplex the bus on a positive-going edge.

Signal Name: **BTS**
 Signal Description: **Bus Type Select**
 Signal Type: **Input**

Strap high to select Motorola bus timing; strap low to select Intel bus timing. This pin controls the function of the RD*(DS*), ALE(AS), and WR*(R/W*) pins. If BTS = 1, then these pins assume the function listed in parenthesis ().

Signal Name: **RD* (DS*)**
 Signal Description: **Read Input (Data Strobe)**
 Signal Type: **Input**
 RD* and DS* are active-low signals. Note: DS is active high when MUX = 1. See bus timing diagrams in Section 23.

Signal Name: **FS0 and FS1**
 Signal Description: **Framer Selects**
 Signal Type: **Input**
 Selects which of the four framers to be accessed.

Signal Name: **CS***
 Signal Description: **Chip Select**
 Signal Type: **Input**
 Must be low to read or write to the device. CS* is an active low signal.

Signal Name: **WR* (R/W*)**
 Signal Description: **Write Input (Read/Write)**
 Signal Type: **Input**
 WR* is an active-low signal.

TEST ACCESS PORT PINS

Signal Name: **Test**
 Signal Description: **3-State Control**
 Signal Type: **Input**
 Set high to tri-state all output and I/O pins (including the parallel control port). Set low for normal operation. Useful in board level testing.

Signal Name: **JTRST***
 Signal Description: **IEEE 1149.1 Test Reset**
 Signal Type: **Input**
 This signal is used to asynchronously reset the test access port controller. At power-up, JTRST* must be set low and then high. This action sets the device into the boundary scan bypass mode allowing normal device operation. If boundary scan is not used, this pin should be held low. This function is available when FMS = 0. *FMS is connected to ground for the DS21FF44/DS21FT44.*

Signal Name: **JTMS**
 Signal Description: **IEEE 1149.1 Test Mode Select**
 Signal Type: **Input**
 This pin is sampled on the rising edge of JTCLK and is used to place the test port into the various defined IEEE 1149.1 states. If not used, this pin should be pulled high. This function is available when FMS = 0. *FMS is connected to ground for the DS21FF44/DS21FT44.*

Signal Name: **JTCLK**
 Signal Description: **IEEE 1149.1 Test Clock Signal**
 Signal Type: **Input**
 This signal is used to shift data into JTDI on the rising edge and out of JTDO on the falling edge. If not used, this pin should be connected to VSS. This function is available when FMS = 0.

Signal Name: **JTDI**
Signal Description: **IEEE 1149.1 Test Data Input**
Signal Type: **Input**

Test instructions and data are clocked into this pin on the rising edge of JTCLK. If not used, this pin should be pulled high. This function is available when FMS = 0. *FMS is connected to ground for the DS21FF44/DS21FT44.*

Signal Name: **JTDO**
Signal Description: **IEEE 1149.1 Test Data Output**
Signal Type: **Output**

Test instructions and data are clocked out of this pin on the falling edge of JTCLK. If not used, this pin should be left unconnected. This function is available when FMS = 0. *FMS is connected to ground for the DS21FF44/DS21FT44.*

SUPPLY PINS

Signal Name: **VDD**
Signal Description: **Positive Supply**
Signal Type: **Supply**
2.97V to 3.63V

Signal Name: **VSS**
Signal Description: **Signal Ground**
Signal Type: **Supply**
0.0V

8. DS21Q44 REGISTER MAP

Table 8-1. REGISTER MAP SORTED BY ADDRESS

ADDRESS	R/W	REGISTER NAME	SYMBOL
00	R	BPV or Code Violation Count 1	VCR1
01	R	BPV or Code Violation Count 2	VCR2
02	R	CRC4 Error Count 1 / FAS Error Count 1	CRCCR1
03	R	CRC4 Error Count 2	CRCCR2
04	R	E-Bit Count 1 / FAS Error Count 2	EBCR1
05	R	E-Bit Count 2	EBCR2
06	R/W	Status 1	SR1
07	R/W	Status 2	SR2
08	R/W	Receive Information	RIR
09	R/W	Test 2	TEST2 (set to 00h)
0A	—	Not used	(set to 00H)
0B	—	Not used	(set to 00H)
0C	—	Not used	(set to 00H)
0D	—	Not used	(set to 00H)
0E	—	Not used	(set to 00H)
0F	R	Device ID	IDR
10	R/W	Receive Control 1	RCR1
11	R/W	Receive Control 2	RCR2
12	R/W	Transmit Control 1	TCR1
13	R/W	Transmit Control 2	TCR2
14	R/W	Common Control 1	CCR1
15	R/W	Test 1	TEST1 (set to 00h)
16	R/W	Interrupt Mask 1	IMR1
17	R/W	Interrupt Mask 2	IMR2
18	—	Not Used	(set to 00H)
19	—	Not Used	(set to 00H)
1A	R/W	Common Control 2	CCR2
1B	R/W	Common Control 3	CCR3
1C	R/W	Transmit Sa Bit Control	TSaCR
1D	R/W	Common Control 6	CCR6
1E	R	Synchronizer Status	SSR
1F	R	Receive Non-Align Frame	RNAF
20	R/W	Transmit Align Frame	TAF
21	R/W	Transmit Non-Align Frame	TNAF
22	R/W	Transmit Channel Blocking 1	TCBR1
23	R/W	Transmit Channel Blocking 2	TCBR2
24	R/W	Transmit Channel Blocking 3	TCBR3
25	R/W	Transmit Channel Blocking 4	TCBR4
26	R/W	Transmit Idle 1	TIR1
27	R/W	Transmit Idle 2	TIR2
28	R/W	Transmit Idle 3	TIR3
29	R/W	Transmit Idle 4	TIR4

ADDRESS	R/W	REGISTER NAME	SYMBOL
2A	R/W	Transmit Idle Definition	TIDR
2B	R/W	Receive Channel Blocking 1	RCBR1
2C	R/W	Receive Channel Blocking 2	RCBR2
2D	R/W	Receive Channel Blocking 3	RCBR3
2E	R/W	Receive Channel Blocking 4	RCBR4
2F	R	Receive Align Frame	RAF
30	R	Receive Signaling 1	RS1
31	R	Receive Signaling 2	RS2
32	R	Receive Signaling 3	RS3
33	R	Receive Signaling 4	RS4
34	R	Receive Signaling 5	RS5
35	R	Receive Signaling 6	RS6
36	R	Receive Signaling 7	RS7
37	R	Receive Signaling 8	RS8
38	R	Receive Signaling 9	RS9
39	R	Receive Signaling 10	RS10
3A	R	Receive Signaling 11	RS11
3B	R	Receive Signaling 12	RS12
3C	R	Receive Signaling 13	RS13
3D	R	Receive Signaling 14	RS14
3E	R	Receive Signaling 15	RS15
3F	R	Receive Signaling 16	RS16
40	R/W	Transmit Signaling 1	TS1
41	R/W	Transmit Signaling 2	TS2
42	R/W	Transmit Signaling 3	TS3
43	R/W	Transmit Signaling 4	TS4
44	R/W	Transmit Signaling 5	TS5
45	R/W	Transmit Signaling 6	TS6
46	R/W	Transmit Signaling 7	TS7
47	R/W	Transmit Signaling 8	TS8
48	R/W	Transmit Signaling 9	TS9
49	R/W	Transmit Signaling 10	TS10
4A	R/W	Transmit Signaling 11	TS11
4B	R/W	Transmit Signaling 12	TS12
4C	R/W	Transmit Signaling 13	TS13
4D	R/W	Transmit Signaling 14	TS14
4E	R/W	Transmit Signaling 15	TS15
4F	R/W	Transmit Signaling 16	TS16
50	R/W	Transmit Si Bits Align Frame	TSiAF
51	R/W	Transmit Si Bits Non-Align Frame	TSiNAF
52	R/W	Transmit Remote Alarm Bits	TRA
53	R/W	Transmit Sa4 Bits	TSa4
54	R/W	Transmit Sa5 Bits	TSa5
55	R/W	Transmit Sa6 Bits	TSa6
56	R/W	Transmit Sa7 Bits	TSa7
57	R/W	Transmit Sa8 Bits	TSa8

ADDRESS	R/W	REGISTER NAME	SYMBOL
58	R	Receive Si Bits Align Frame	RSiAF
59	R	Receive Si Bits Non-Align Frame	RSiNAF
5A	R	Receive Remote Alarm Bits	RRA
5B	R	Receive Sa4 Bits	RSa4
5C	R	Receive Sa5 Bits	RSa5
5D	R	Receive Sa6 Bits	RSa6
5E	R	Receive Sa7 Bits	RSa7
5F	R	Receive Sa8 Bits	RSa8
60	R/W	Transmit Channel 1	TC1
61	R/W	Transmit Channel 2	TC2
62	R/W	Transmit Channel 3	TC3
63	R/W	Transmit Channel 4	TC4
64	R/W	Transmit Channel 5	TC5
65	R/W	Transmit Channel 6	TC6
66	R/W	Transmit Channel 7	TC7
67	R/W	Transmit Channel 8	TC8
68	R/W	Transmit Channel 9	TC9
69	R/W	Transmit Channel 10	TC10
6A	R/W	Transmit Channel 11	TC11
6B	R/W	Transmit Channel 12	TC12
6C	R/W	Transmit Channel 13	TC13
6D	R/W	Transmit Channel 14	TC14
6E	R/W	Transmit Channel 15	TC15
6F	R/W	Transmit Channel 16	TC16
70	R/W	Transmit Channel 17	TC17
71	R/W	Transmit Channel 18	TC18
72	R/W	Transmit Channel 19	TC19
73	R/W	Transmit Channel 20	TC20
74	R/W	Transmit Channel 21	TC21
75	R/W	Transmit Channel 22	TC22
76	R/W	Transmit Channel 23	TC23
77	R/W	Transmit Channel 24	TC24
78	R/W	Transmit Channel 25	TC25
79	R/W	Transmit Channel 26	TC26
7A	R/W	Transmit Channel 27	TC27
7B	R/W	Transmit Channel 28	TC28
7C	R/W	Transmit Channel 29	TC29
7D	R/W	Transmit Channel 30	TC30
7E	R/W	Transmit Channel 31	TC31
7F	R/W	Transmit Channel 32	TC32
80	R/W	Receive Channel 1	RC1
81	R/W	Receive Channel 2	RC2
82	R/W	Receive Channel 3	RC3
83	R/W	Receive Channel 4	RC4
84	R/W	Receive Channel 5	RC5
85	R/W	Receive Channel 6	RC6

ADDRESS	R/W	REGISTER NAME	SYMBOL
86	R/W	Receive Channel 7	RC7
87	R/W	Receive Channel 8	RC8
88	R/W	Receive Channel 9	RC9
89	R/W	Receive Channel 10	RC10
8A	R/W	Receive Channel 11	RC11
8B	R/W	Receive Channel 12	RC12
8C	R/W	Receive Channel 13	RC13
8D	R/W	Receive Channel 14	RC14
8E	R/W	Receive Channel 15	RC15
8F	R/W	Receive Channel 16	RC16
90	R/W	Receive Channel 17	RC17
91	R/W	Receive Channel 18	RC18
92	R/W	Receive Channel 19	RC19
93	R/W	Receive Channel 20	RC20
94	R/W	Receive Channel 21	RC21
95	R/W	Receive Channel 22	RC22
96	R/W	Receive Channel 23	RC23
97	R/W	Receive Channel 24	RC24
98	R/W	Receive Channel 25	RC25
99	R/W	Receive Channel 26	RC26
9A	R/W	Receive Channel 27	RC27
9B	R/W	Receive Channel 28	RC28
9C	R/W	Receive Channel 29	RC29
9D	R/W	Receive Channel 30	RC30
9E	R/W	Receive Channel 31	RC31
9F	R/W	Receive Channel 32	RC32
A0	R/W	Transmit Channel Control 1	TCC1
A1	R/W	Transmit Channel Control 2	TCC2
A2	R/W	Transmit Channel Control 3	TCC3
A3	R/W	Transmit Channel Control 4	TCC4
A4	R/W	Receive Channel Control 1	RCC1
A5	R/W	Receive Channel Control 2	RCC2
A6	R/W	Receive Channel Control 3	RCC3
A7	R/W	Receive Channel Control 4	RCC4
A8	R/W	Common Control 4	CCR4
A9	R	Transmit DS0 Monitor	TDS0M
AA	R/W	Common Control 5	CCR5
AB	R	Receive DS0 Monitor	RDS0M
AC	R/W	Test 3	TEST3 (set to 00H)
AD	—	Not Used	(set to 00H)
AE	—	Not Used	(set to 00H)
AF	—	Not Used	(set to 00H)
B0	R/W	HDLC Control Register	HCR
B1	R/W	HDLC Status Register	HSR
B2	R/W	HDLC Interrupt Mask Register	HIMR
B3	R/W	Receive HDLC Information Register	RHIR

ADDRESS	R/W	REGISTER NAME	SYMBOL
B4	R/W	Receive HDLC FIFO Register	RHFR
B5	R/W	Interleave Bus Operation Register	IBO
B6	R/W	Transmit HDLC Information Register	THIR
B7	R/W	Transmit HDLC FIFO Register	THFR
B8	R/W	Receive HDLC DS0 Control Register 1	RDC1
B9	R/W	Receive HDLC DS0 Control Register 2	RDC2
BA	R/W	Transmit HDLC DS0 Control Register 1	TDC1
BB	R/W	Transmit HDLC DS0 Control Register 2	TDC2
BC	—	Not Used	(set to 00H)
BD	—	Not Used	(set to 00H)
BE	—	Not Used	(set to 00H)
BF	—	Not Used	(set to 00H)

NOTES:

- 1) Test Registers 1, 2, and 3 are used only by the factory; these registers must be cleared (set to all 0's) on power-up initialization to ensure proper operation.
- 2) Register banks CxH, DxH, ExH, and FxH are not accessible.

9. PARALLEL PORT

The DS21Q44 is controlled by either a nonmultiplexed (MUX = 0) or a multiplexed (MUX = 1) bus by an external microcontroller or microprocessor. The DS21Q44 can operate with either Intel or Motorola bus timing configurations. If the BTS pin is connected low, Intel timing will be selected; if connected high, Motorola timing will be selected. All Motorola bus signals are listed in parenthesis (). See the timing diagrams in the A.C. Electrical Characteristics in Section 23 for more details.

10. CONTROL, ID, AND TEST REGISTERS

The operation of each framer within the DS21Q44 is configured by a set of 10 control registers. Typically, the control registers are only accessed when the system is first powered up. Once a channel in the DS21Q44 has been initialized, the control registers will only need to be accessed when there is a change in the system configuration. There are two Receive Control Register (RCR1 and RCR2), two Transmit Control Registers (TCR1 and TCR2), and six Common Control Registers (CCR1 to CCR6). Each of the ten registers are described in this section.

There is a device Identification Register (IDR) at address 0Fh. The MSB of this read-only register is fixed to a one indicating that the DS21Q44 is present. The T1 pin-for-pin compatible version of the DS21Q44 is the DS21Q42 and it also has an ID register at address 0Fh and the user can read the MSB to determine which chip is present since in the DS21Q42 the MSB will be set to a 0 and in the DS21Q44 it will be set to a one. The lower 4 bits of the IDR are used to display the die revision of the chip.

Power-Up Sequence

The DS21Q44 does not automatically clear its register space on power-up. After the supplies are stable, each of the four framer's register space should be configured for operation by writing to all of the internal registers. This includes setting the Test and all unused registers to 00Hex.

This can be accomplished using a two-pass approach on each framer within the DS21Q44.

- 1) Clear framer's register space by writing 00H to the addresses 00H through 0BFH.
- 2) Program required registers to achieve desired operating mode.

NOTE:

When emulating the DS21Q43 feature set (FMS = 1), the full address space (00H through 0BFH) must be initialized. DS21Q43 emulation require address pin A7 to be used. *FMS is connected to ground for the DS21FF44/DS21FT44.*

Finally, after the TSYCLK and RSYCLK inputs are stable, the ESR bit should be toggled from a zero to a one (this step can be skipped if the elastic stores are disabled).

IDR: DEVICE IDENTIFICATION REGISTER (Address = 0F Hex)

(MSB)	T1E1	0	0	0	ID3	ID2	ID1	(LSB)	ID0
--------------	------	---	---	---	-----	-----	-----	--------------	-----

SYMBOL	POSITION	NAME AND DESCRIPTION
T1E1	IDR.7	T1 or E1 Chip Determination Bit 0 = T1 chip 1 = E1 chip
ID3	IDR.3	Chip Revision Bit 3. MSB of a decimal code that represents the chip revision.
ID2	IDR.1	Chip Revision Bit 2
ID1	IDR.2	Chip Revision Bit 1
ID0	IDR.0	Chip Revision Bit 0. LSB of a decimal code that represents the chip revision.

RCR1: RECEIVE CONTROL REGISTER 1 (Address = 10 Hex)

(MSB)	RSMF	RSM	RSIO	—	—	FRC	SYNCE	(LSB)	RESYNC
--------------	------	-----	------	---	---	-----	-------	--------------	--------

SYMBOL	POSITION	NAME AND DESCRIPTION
RSMF	RCR1.7	RSYNC Multiframe Function. Only used if the RSYNC pin is programmed in the multiframe mode (RCR1.6 = 1). 0 = RSYNC outputs CAS multiframe boundaries 1 = RSYNC outputs CRC4 multiframe boundaries
RSM	RCR1.6	RSYNC Mode Select 0 = frame mode (See timing diagrams in Section 22.) 1 = multiframe mode (See timing diagrams in Section 22.)
RSIO	RCR1.5	RSYNC I/O Select. (Note: this bit must be set to zero when RCR2.1 = 0). 0 = RSYNC is an output (depends on RCR1.6) 1 = RSYNC is an input (only valid if elastic store enabled)
—	RCR1.4	Not Assigned. Should be set to zero when written.
—	RCR1.3	Not Assigned. Should be set to zero when written.
FRC	RCR1.2	Frame Resync Criteria 0 = resync if FAS received in error three consecutive times 1 = resync if FAS or bit 2 of non-FAS is received in error three consecutive times
SYNCE	RCR1.1	Sync Enable 0 = auto resync enabled 1 = auto resync disabled
RESYNC	RCR1.0	Resync. When toggled from low to high, a resync is initiated. Must be cleared and set again for a subsequent resync.

Table 10–1. SYNC/RESYNC CRITERIA

FRAME OR MULTIFRAME LEVEL	SYNC CRITERIA	RESYNC CRITERIA	ITU SPEC.
FAS	FAS present in frame N and N + 2, and FAS not present in frame N + 1	Three consecutive incorrect FAS received Alternate (RCR1.2 = 1) the above criteria is met or three consecutive incorrect bit 2 of non-FAS received	G.706 4.1.1 4.1.2
CRC4	Two valid MF alignment words found within 8 ms	915 or more CRC4 code words out of 1000 received in error	G.706 4.2 and 4.3.2
CAS	Valid MF alignment word found and previous timeslot 16 contains code other than all zeros	Two consecutive MF alignment words received in error	G.732 5.2

RCR2: RECEIVE CONTROL REGISTER 2 (Address = 11 Hex)

(MSB)						(LSB)	
Sa8S	Sa7S	Sa6S	Sa5S	Sa4S	RBCS	RESE	—

SYMBOL	POSITION	NAME AND DESCRIPTION
Sa8S	RCR2.7	Sa8 Bit Select. Set to one to have RLCLK pulse at the Sa8 bit position; set to zero to force RLCLK low during Sa8 bit position. See Section 22 for timing details.
Sa7S	RCR2.6	Sa7 Bit Select. Set to one to have RLCLK pulse at the Sa7 bit position; set to zero to force RLCLK low during Sa7 bit position. See Section 22 for timing details.
Sa6S	RCR2.5	Sa6 Bit Select. Set to one to have RLCLK pulse at the Sa6 bit position; set to zero to force RLCLK low during Sa6 bit position. See Section 22 for timing details.
Sa5S	RCR2.4	Sa5 Bit Select. Set to one to have RLCLK pulse at the Sa5 bit position; set to zero to force RLCLK low during Sa5 bit position. See Section 22 for timing details.
Sa4S	RCR2.3	Sa4 Bit Select. Set to one to have RLCLK pulse at the Sa4 bit position; set to zero to force RLCLK low during Sa4 bit position. See Section 22 for timing details.
RBCS	RCR2.2	Receive Side Backplane Clock Select 0 = if RSYSCLK is 1.544MHz 1 = if RSYSCLK is 2.048MHz
RESE	RCR2.1	Receive Side Elastic Store Enable 0 = elastic store is bypassed 1 = elastic store is enabled
—	RCR2.0	Not Assigned. Should be set to zero when written.

TCR1: TRANSMIT CONTROL REGISTER 1 (Address = 12 Hex)

(MSB)				(LSB)			
ODF	TFPT	T16S	TUA1	TSiS	TSA1	TSM	TSIO
SYMBOL	POSITION	NAME AND DESCRIPTION					
ODF	TCR1.7	Output Data Format 0 = bipolar data at TPOS and TNEG 1 = NRZ data at TPOS; TNEG = 0					
TFPT	TCR1.6	Transmit Timeslot 0 Pass Through 0 = FAS bits/Sa bits/Remote Alarm sourced internally from the TAF and TNAF registers 1 = FAS bits/Sa bits/Remote Alarm sourced from TSER					
T16S	TCR1.5	Transmit Timeslot 16 Data Select 0 = sample timeslot 16 at TSER pin 1 = source timeslot 16 from TS0 to TS15 registers					
TUA1	TCR1.4	Transmit Unframed All Ones 0 = transmit data normally 1 = transmit an unframed all one's code at TPOS and TNEG					
TSiS	TCR1.3	Transmit International Bit Select 0 = sample Si bits at TSER pin 1 = source Si bits from TAF and TNAF registers (in this mode, TCR1.6 must be set to 0)					
TSA1	TCR1.2	Transmit Signaling All Ones 0 = normal operation 1 = force timeslot 16 in every frame to all ones					
TSM	CR1.1	TSYNC Mode Select 0 = frame mode (see the timing in Section 22) 1 = CAS and CRC4 multiframe mode (see the timing in Section 22)					
TSIO	TCR1.0	TSYNC I/O Select 0 = TSYNC is an input 1 = TSYNC is an output					

Note: See Figure 22–15 for more details about how the Transmit Control Registers affect the operation of the DS21Q44.

TCR2: TRANSMIT CONTROL REGISTER 2 (Address = 13 Hex)

(MSB)				(LSB)			
Sa8S	Sa7S	Sa6S	Sa5S	Sa4S	ODM	AEBE	PF
SYMBOL	POSITION	NAME AND DESCRIPTION					
Sa8S	TCR2.7	Sa8 Bit Select. Set to one to source the Sa8 bit from the TLINK pin; set to zero to not source the Sa8 bit. See Section 22 for timing details.					
Sa7S	TCR2.6	Sa7 Bit Select. Set to one to source the Sa7 bit from the TLINK pin; set to zero to not source the Sa7 bit. See Section 22 for timing details.					
Sa6S	TCR2.5	Sa6 Bit Select. Set to one to source the Sa6 bit from the TLINK pin; set to zero to not source the Sa6 bit. See Section 22 for timing details.					
Sa5S	TCR2.4	Sa5 Bit Select. Set to one to source the Sa5 bit from the TLINK pin; set to zero to not source the Sa5 bit. See Section 22 for timing details.					
Sa4S	TCR2.3	Sa4 Bit Select. Set to one to source the Sa4 bit from the TLINK pin; set to zero to not source the Sa4 bit. See Section 22 for timing details.					
ODM	TCR2.2	Output Data Mode 0 = pulses at TPOSO and TNEGO are one full TCLKO period wide 1 = pulses at TPOSO and TNEGO are 1/2 TCLKO period wide					
AEBE	TCR2.1	Automatic E-Bit Enable 0 = E-bits not automatically set in the transmit direction 1 = E-bits automatically set in the transmit direction					
PF	TCR2.0	Function of RLOS/LOTIC Pin 0 = Receive Loss of Sync (RLOS) 1 = Loss of Transmit Clock (LOTIC)					

CCR1: COMMON CONTROL REGISTER 1 (Address = 14 Hex)**(MSB)****(LSB)**

FLB	THDB3	TG802	TCRC4	RSM	RHDB3	RG802	RCRC4
-----	-------	-------	-------	-----	-------	-------	-------

SYMBOL	POSITION	NAME AND DESCRIPTION
FLB	CCR1.7	Framer Loopback 0 = loopback disabled 1 = loopback enabled
THDB3	CCR1.6	Transmit HDB3 Enable 0 = HDB3 disabled 1 = HDB3 enabled
TG802	CCR1.5	Transmit G.802 Enable. See Section 22 for details. 0 = do not force TCHBLK high during bit 1 of timeslot 26 1 = force TCHBLK high during bit 1 of timeslot 26
TCRC4	CCR1.4	Transmit CRC4 Enable 0 = CRC4 disabled 1 = CRC4 enabled
RSM	CCR1.3	Receive Signaling Mode Select 0 = CAS signaling mode 1 = CCS signaling mode
RHDB3	CCR1.2	Receive HDB3 Enable 0 = HDB3 disabled 1 = HDB3 enabled
RG802	CCR1.1	Receive G.802 Enable. See Section 22 for details. 0 = do not force RCHBLK high during bit 1 of timeslot 26 1 = force RCHBLK high during bit 1 of timeslot 26
RCRC4	CCR1.0	Receive CRC4 Enable 0 = CRC4 disabled 1 = CRC4 enabled

FRAMER LOOPBACK

When CCR1.7 is set to a one, the framer will enter a Framer LoopBack (FLB) mode. See Figure 6–1 for more details. This loopback is useful in testing and debugging applications. In FLB, the framer will loop data from the transmit side back to the receive side. When FLB is enabled, the following will occur:

- 1) Data will be transmitted as normal at TPOS and TNEG.
- 2) Data input by RPOS and RNEG will be ignored.
- 3) The RCLK output will be replaced with the TCLK input.

CCR2: COMMON CONTROL REGISTER 2 (Address = 1A Hex)

(MSB)								(LSB)
ECUS	VCRFS	AAIS	ARA	RSERC	LOTCMC	RFF	RFE	
SYMBOL	POSITION	NAME AND DESCRIPTION						
ECUS	CCR2.7	Error Counter Update Select. See Section 12 for details. 0 = update error counters once a second 1 = update error counters every 62.5ms (500 frames)						
VCRFS	CCR2.6	VCR Function Select. See Section 12 for details. 0 = count BiPolar Violations (BPVs) 1 = count Code Violations (CVs)						
AAIS	CCR2.5	Automatic AIS Generation 0 = disabled 1 = enabled						
ARA	CCR2.4	Automatic Remote Alarm Generation 0 = disabled 1 = enabled						
RSERC	CCR2.3	RSER Control 0 = allow RSER to output data as received under all conditions 1 = force RSER to one under loss of frame alignment conditions						
LOTCMC	CCR2.2	Loss of Transmit Clock Mux Control. Determines whether the transmit side formatter should switch to the ever present RCLK if the TCLK should fail to transition (Figure 6–1). 0 = do not switch to RCLK if TCLK stops 1 = switch to RCLK if TCLK stops						
RFF	CCR2.1	Receive Force Freeze. Freezes receive side signaling at RSIG (and RSER if CCR3.3 = 1); will override Receive Freeze Enable (RFE). See Section 14 or details. 0 = do not force a freeze event 1 = force a freeze event						
RFE	CCR2.0	Receive Freeze Enable. See Section 14 for details. 0 = no freezing of receive signaling data will occur 1 = allow freezing of receive signaling data at RSIG (and RSER if CCR3.3 = 1)						

AUTOMATIC ALARM GENERATION

The DS21Q44 can be programmed to automatically transmit AIS or Remote Alarm. When automatic AIS generation is enabled (CCR2.5 = 1), the framer monitors the receive side to determine if any of the following conditions are present: loss of receive frame synchronization, AIS alarm (all one's) reception, or loss of receive carrier (or signal). If any one (or more) of the above conditions is present, then the framer will transmit an AIS alarm.

When automatic RAI generation is enabled (CCR2.4 = 1), the framer monitors the receive side to determine if any of the following conditions are present: loss of receive frame synchronization, AIS alarm (all one's) reception, loss of receive carrier or if CRC4 multiframe synchronization (if enabled) cannot be found within 128ms of FAS synchronization. If any one (or more) of the above conditions is present, then the framer will transmit a RAI alarm. RAI generation conforms to ETS 300 011 specifications and a

constant Remote Alarm will be transmitted if the framer cannot find CRC4 multiframe synchronization within 400ms as per G.706.

It is an illegal state to have both CCR2.4 and CCR2.5 set to one at the same time.

CCR3: COMMON CONTROL REGISTER 3 (Address = 1B Hex)

(MSB)				(LSB)			
TESE	TCBFS	TIRFS	—	RSRE	THSE	TBCS	RCLA
SYMBOL	POSITION	NAME AND DESCRIPTION					
TESE	CCR3.7	Transmit Side Elastic Store Enable 0 = elastic store is bypassed 1 = elastic store is enabled					
TCBFS	CCR3.6	Transmit Channel Blocking Registers (TCBR) Function Select 0 = TCBRs define the operation of the TCHBLK output pin 1 = TCBRs define which signaling bits are to be inserted					
TIRFS	CCR3.5	Transmit Idle Registers (TIR) Function Select. See Section 15 for details. 0 = TIRs define in which channels to insert idle code 1 = TIRs define in which channels to insert data from RSER (i.e., Per Channel Loopback function)					
—	CCR3.4	Not Assigned. Should be set to zero when written.					
RSRE	CCR3.3	Receive Side Signaling Reinsertion Enable. See Section 14 for details. 0 = do not reinsert signaling bits into the data stream presented at the RSER pin 1 = reinsert the signaling bits into data stream presented at the RSER pin					
THSE	CCR3.2	Transmit Side Hardware Signaling Insertion Enable. See Section 14 for details. 0 = do not insert signaling from the TSIG pin into the data stream presented at the TSER pin 1 = insert signaling from the TSIG pin into the data stream presented at the TSER pin					
TBCS	CCR3.1	Transmit Side Backplane Clock Select 0 = if TSYCLK is 1.544MHz 1 = if TSYCLK is 2.048MHz					
RCLA	CCR3.0	Receive Carrier Loss (RCL) Alternate Criteria 0 = RCL declared upon 255 consecutive zeros (125µs) 1 = RCL declared upon 2048 consecutive zeros (1ms)					

CCR4: COMMON CONTROL REGISTER 4 (Address = A8 Hex)**(MSB)****(LSB)**

RLB	—	—	TCM4	TCM3	TCM2	TCM1	TCM0
-----	---	---	------	------	------	------	------

SYMBOL	POSITION	NAME AND DESCRIPTION
RLB	CCR4.7	Remote Loopback 0 = loopback disabled 1 = loopback enabled
—	CCR4.6	Not Assigned. Should be set to zero when written.
—	CCR4.5	Not Assigned. Should be set to zero when written.
TCM4	CCR4.4	Transmit Channel Monitor Bit 4. MSB of a channel decode that determines which transmit channel data appears in the TDS0M register (Section 13).
TCM3	CCR4.3	Transmit Channel Monitor Bit 3
TCM2	CCR4.2	Transmit Channel Monitor Bit 2
TCM1	CCR4.1	Transmit Channel Monitor Bit 1
TCM0	CCR4.0	Transmit Channel Monitor Bit 0. LSB of the channel decode.

CCR5: COMMON CONTROL REGISTER 5 (Address = AA Hex)**(MSB)****(LSB)**

—	RESALGN	TESALGN	RCM4	RCM3	RCM2	RCM1	RCM0
---	---------	---------	------	------	------	------	------

SYMBOL	POSITION	NAME AND DESCRIPTION
—	CCR5.7	Not Assigned. Should be set to zero when written
RESALGN	CCR5.6	Receive Elastic Store Align. Setting this bit from a zero to a one may force the receive elastic store's write/read pointers to a minimum separation of half a frame. No action will be taken if the pointer separation is already greater or equal to half a frame. If pointer separation is less than half a frame, the command will be executed and data will be disrupted. Should be toggled after RSYCLK has been applied and is stable. Must be cleared and set again for a subsequent align (Section 17).
TESALGN	CCR5.5	Transmit Elastic Store Align. Setting this bit from a zero to a one may force the transmit elastic store's write/read pointers to a minimum separation of half a frame. No action is taken if the pointer separation is already greater or equal to half a frame. If pointer separation is less than half a frame, the command will be executed and data will be disrupted. Should be toggled after TSYCLK has been applied and is stable. Must be cleared and set again for a subsequent align (Section 17).
RCM4	CCR5.4	Receive Channel Monitor Bit 4. MSB of a channel decode that determines which receive channel data appears in the RDS0M register (Section 13).
RCM3	CCR5.3	Receive Channel Monitor Bit 3
RCM2	CCR5.2	Receive Channel Monitor Bit 2
RCM1	CCR5.1	Receive Channel Monitor Bit 1
RCM0	CCR5.0	Receive Channel Monitor Bit 0. LSB of the channel decode.

CCR6: COMMON CONTROL REGISTER 6 (Address = 1D Hex)**(MSB)****(LSB)**

—	—	—	—	—	TCLKSRC	RESR	TESR
---	---	---	---	---	---------	------	------

SYMBOL	POSITION	NAME AND DESCRIPTION
—	CCR6.7	Not Assigned. Should be set to zero when written
—	CCR6.6	Not Assigned. Should be set to zero when written
—	CCR6.5	Not Assigned. Should be set to zero when written
—	CCR6.4	Not Assigned. Should be set to zero when written
—	CCR6.3	Not Assigned. Should be set to zero when written
TCLKSRC	CCR6.2	Transmit Clock Source Select. This function allows the user to internally select RCLK as the clock source for the transmit side formatter. 0 = transmit side formatter clocked with signal applied at TCLK pin. LOTC Mux function is operational (TCR1.7) 1 = transmit side formatter clocked with RCLK.
RESR	CCR6.1	Receive Elastic Store Reset. Setting this bit from a zero to a one will force the receive elastic store to a depth of one frame. Receive data is lost during the reset. Should be toggled after RSYCLK has been applied and is stable. Do not leave this bit set high.
TESR	CCR6.0	Transmit Elastic Store Reset. Setting this bit from a zero to a one will force the transmit elastic store to a depth of one frame. Transmit data is lost during the reset. Should be toggled after TSYCLK has been applied and is stable. Do not leave this bit set high.

11. STATUS AND INFORMATION REGISTERS

There is a set of seven registers per framer that contain information on the current real time status of a framer in the DS21Q44, Status Register 1 (SR1), Status Register 2 (SR2), Receive Information Register (RIR), Synchronizer status Register (SSR) and a set of three registers for the onboard HDLC controller. The specific details on the four registers pertaining to the HDLC controller are covered in Section 19 but they operate the same as the other status registers in the DS21Q44 and this operation is described below.

When a particular event has occurred (or is occurring), the appropriate bit in one of these four registers will be set to a one. All of the bits in SR1, SR2, and RIR1 registers operate in a latched fashion. The Synchronizer status Register contents are not latched. This means that if an event or an alarm occurs and a bit is set to a one in any of the registers, it will remain set until the user reads that bit. The bit will be cleared when it is read and it will not be set again until the event has occurred again (or in the case of the RSA1, RSA0, RDMA, RUA1, RRA, RCL, and RLOS alarms, the bit will remain set if the alarm is still present).

The user will always precede a read of any of the SR1, SR2 and RIR registers with a write. The byte written to the register will inform the framer which bits the user wishes to read and have cleared. The user will write a byte to one of these registers, with a one in the bit positions he or she wishes to read and a zero in the bit positions he or she does not wish to obtain the latest information on. When a one is written to a bit location, the read register will be updated with the latest information. When a zero is written to a bit position, the read register will not be updated and the previous value will be held. A write

to the status and information registers will be immediately followed by a read of the same register. The read result should be logically AND'ed with the mask byte that was just written and this value should be written back into the same register to insure that bit does indeed clear. This second write step is necessary because the alarms and events in the status registers occur asynchronously in respect to their access by the parallel port. This write-read-write scheme allows an external microcontroller or microprocessor to individually poll certain bits without disturbing the other bits in the register. This operation is key in controlling the DS21Q44 with higher-order software languages.

The SSR register operates differently than the other three. It is a read only register and it reports the status of the synchronizer in real time. This register is not latched and it is not necessary to precede a read of this register with a write.

The SR1, SR2, and HSR registers have the unique ability to initiate a hardware interrupt by the INT* output pin. Each of the alarms and events in the SR1, SR2, and HSR can be either masked or unmasked from the interrupt pin by the Interrupt Mask Register 1 (IMR1), Interrupt Mask Register 2 (IMR2), and HDLC Interrupt Mask Register (HIMR) respectively. The HIMR register is covered in Section 19.

The interrupts caused by four of the alarms in SR1 (namely RUA1, RRA, RCL, and RLOS) act differently than the interrupts caused by other alarms and events in SR1 and SR2 (namely RSA1, RDMA, RSA0, RSLIP, RMF, RAF, TMF, SEC, TAF, LOTC, RCMF, and TSLIP). These four alarm interrupts will force the INT* pin low whenever the alarm changes state (i.e., the alarm goes active or inactive according to the set/clear criteria in Table 11-1). The INT* pin will be allowed to return high (if no other interrupts are present) when the user reads the alarm bit that caused the interrupt to occur. If the alarm is still present, the register bit will remain set.

The event caused interrupts will force the INT* pin low when the event occurs. The INT* pin will be allowed to return high (if no other interrupts are present) when the user reads the event bit that caused the interrupt to occur.

ISR: INTERRUPT STATUS REGISTER (Any address from 0C0 Hex to 0FF Hex)

(MSB)				(LSB)			
F3HDLC	F3SR	F2HDLC	F2SR	F1HDLC	F1SR	F0HDLC	F0SR
SYMBOL	POSITION	NAME AND DESCRIPTION					
F3HDLC	ISR.7	Framer 3 HDLC Controller Interrupt Request 0 = No interrupt request pending 1 = Interrupt request pending					
F3SR	ISR.6	Framer 3 SR1 or SR2 Interrupt Request 0 = No interrupt request pending 1 = Interrupt request pending					
F2HDLC	ISR.5	Framer 2 HDLC Controller Interrupt Request 0 = No interrupt request pending 1 = Interrupt request pending					
F2SR	ISR.4	Framer 2 SR1 or SR2 Interrupt Request 0 = No interrupt request pending 1 = Interrupt request pending					
F1HDLC	ISR.3	Framer 1 HDLC Controller Interrupt Request 0 = No interrupt request pending 1 = Interrupt request pending					
F1SR	ISR.2	Framer 1 SR1 or SR2 Interrupt Request 0 = No interrupt request pending 1 = Interrupt request pending					
F0HDLC	ISR.1	Framer 0 HDLC Controller Interrupt Request 0 = No interrupt request pending 1 = Interrupt request pending					
F0SR	ISR.0	Framer 0 SR1 or SR2 Interrupt Request 0 = No interrupt request pending 1 = Interrupt request pending					

RIR: RECEIVE INFORMATION REGISTER (Address = 08 Hex)**(MSB)****(LSB)**

TESF	TESE	LORC	RESF	RESE	CRCRC	FASRC	CASRC
------	------	------	------	------	-------	-------	-------

SYMBOL	POSITION	NAME AND DESCRIPTION
TESF	RIR.7	Transmit Side Elastic Store Full. Set when the transmit side elastic store buffer fills and a frame is deleted.
TESE	RIR.6	Transmit Side Elastic Store Empty. Set when the transmit side elastic store buffer empties and a frame is repeated.
LORC	RIR.5	Loss of Receive Clock. Set when the RCLK pin has not transitioned for at least 2 μ s (3 μ s \pm 1 μ s).
RESF	RIR.4	Receive Side Elastic Store Full. Set when the receive side elastic store buffer fills and a frame is deleted.
RESE	RIR.3	Receive Side Elastic Store Empty. Set when the receive side elastic store buffer empties and a frame is repeated.
CRCRC	RIR.2	CRC Resync Criteria Met. Set when 915/1000 code words are received in error.
FASRC	RIR.1	FAS Resync Criteria Met. Set when three consecutive FAS words are received in error.
CASRC	RIR.0	CAS Resync Criteria Met. Set when two consecutive CAS MF alignment words are received in error.

SSR: SYNCHRONIZER STATUS REGISTER (Address = 1E Hex)**(MSB)****(LSB)**

CSC5	CSC4	CSC3	CSC2	CSC0	FASSA	CASSA	CRC4SA
------	------	------	------	------	-------	-------	--------

SYMBOL	POSITION	NAME AND DESCRIPTION
CSC5	SSR.7	CRC4 Sync Counter Bit 5. MSB of the 6-bit counter.
CSC4	SSR.6	CRC4 Sync Counter Bit 4
CSC3	SSR.5	CRC4 Sync Counter Bit 3
CSC2	SSR.4	CRC4 Sync Counter Bit 2
CSC0	SSR.3	CRC4 Sync Counter Bit 0. LSB of the 6-bit counter. The next to LSB is not accessible.
FASSA	SSR.2	FAS Sync Active. Set while the synchronizer is searching for alignment at the FAS level.
CASSA	SSR.1	CAS MF Sync Active. Set while the synchronizer is searching for the CAS MF alignment word.
CRC4SA	SSR.0	CRC4 MF Sync Active. Set while the synchronizer is searching for the CRC4 MF alignment word.

CRC4 SYNC COUNTER

The CRC4 Sync Counter increments each time the 8ms CRC4 multiframe search times out. The counter is cleared when the framer has successfully obtained synchronization at the CRC4 level. The counter can also be cleared by disabling the CRC4 mode (CCR1.0=0). This counter is useful for determining the amount of time the framer has been searching for synchronization at the CRC4 level. ITU G.706 suggests

that if synchronization at the CRC4 level cannot be obtained within 400ms, then the search should be abandoned and proper action taken. The CRC4 Sync Counter rolls over.

SR1: STATUS REGISTER 1 (Address = 06 Hex)

(MSB)								(LSB)	
RSA1	RDMA	RSA0	RSLIP	RUA1	RRA	RCL	RLOS		
SYMBOL	POSITION	NAME AND DESCRIPTION							
RSA1	SR1.7	Receive Signaling All Ones/Signaling Change. Set when over a full MF, the content of timeslot 16 contains fewer than three zeros. This alarm is not disabled in the CCS signaling mode. A change in the contents of RS1 through RS16 from one multiframe to the next will cause RSA1 and RSA0 to be set.							
RDMA	SR1.6	Receive Distant MF Alarm. Set when bit 6 of timeslot 16 in frame 0 has been set for two consecutive multiframes. This alarm is not disabled in the CCS signaling mode.							
RSA0	SR1.5	Receive Signaling All Zeros/Signaling Change. Set when over a full MF, timeslot 16 contains all zeros. A change in the contents of RS1 through RS16 from one multiframe to the next will cause RSA1 and RSA0 to be set.							
RSLIP	SR1.4	Receive Side Elastic Store Slip. Set when the elastic store has either repeated or deleted a frame of data.							
RUA1	SR1.3	Receive Unframed All Ones. Set when an unframed all ones code is received at RPOS and RNEG.							
RRA	SR1.2	Receive Remote Alarm. Set when a remote alarm is received at RPOS and RNEG.							
RCL	SR1.1	Receive Carrier Loss. Set when 255 (or 2048 if CCR3.0 = 1) consecutive zeros have been detected at RPOS and RNEG.							
RLOS	SR1.0	Receive Loss of Sync. Set when the device is not synchronized to the receive E1 stream.							

Table 11-1. ALARM CRITERIA

ALARM	SET CRITERIA	CLEAR CRITERIA	ITU SPEC.
RSA1 (receive signaling all 1's)	Over 16 consecutive frames (one full MF) timeslot 16 contains less than three 0's	Over 16 consecutive frames (one full MF) timeslot 16 contains three or more 0's	G.732 4.2
RSA0 (receive signaling all 0's)	Over 16 consecutive frames (one full MF) timeslot 16 contains all 0's	Over 16 consecutive frames (one full MF) timeslot 16 contains at least a single 1	G.732 5.2
RDMA (receive distant multiframe alarm)	Bit 6 in timeslot 16 of frame 0 set to 1 for two consecutive MF	Bit 6 in timeslot 16 of frame 0 set to 0 for two consecutive MF	O.162 2.1.5
RUA1 (receive unframed all 1's)	Less than three 0's in two frames (512 bits)	More than two 0's in two frames (512 bits)	O.162 1.6.1.2
RRA (receive remote alarm)	Bit 3 of nonalign frame set to one for three consecutive occasions	Bit 3 of nonalign frame set to 0 for three consecutive occasions	O.162 2.1.4
RCL (receive carrier loss)	255 (or 2048) consecutive 0's received	In 255 bit times, at least 32 1's are received	G.775/G.962

SR2: STATUS REGISTER 2 (Address = 07 Hex)

(MSB)								(LSB)
RMF	RAF	TMF	SEC	TAF	LOTC	RCMF	TSLIP	
SYMBOL	POSITION	NAME AND DESCRIPTION						
RMF	SR2.7	Receive CAS Multiframe. Set every 2ms (regardless if CAS signaling is enabled or not) on receive multiframe boundaries. Used to alert the host that signaling data is available.						
RAF	SR2.6	Receive Align Frame. Set every 250µs at the beginning of align frames. Used to alert the host that Si and Sa bits are available in the RAF and RNAF registers.						
TMF	SR2.5	Transmit Multiframe. Set every 2ms (regardless if CRC4 is enabled) on transmit multiframe boundaries. Used to alert the host that signaling data needs to be updated.						
SEC	SR2.4	One Second Timer. Set on increments of one second based on RCLK. If CCR2.7 = 1, then this bit will be set every 62.5ms instead of once a second.						
TAF	SR2.3	Transmit Align Frame. Set every 250µs at the beginning of align frames. Used to alert the host that the TAF and TNAF registers need to be updated.						
LOTC	SR2.2	Loss of Transmit Clock. Set when the TCLK pin has not transitioned for one channel time (or 3.9µs). Will force the LOTC pin high if enabled by TCR2.0.						
RCMF	SR2.1	Receive CRC4 Multiframe. Set on CRC4 multiframe boundaries; will continue to be set every 2ms on an arbitrary boundary if CRC4 is disabled.						
TSLIP	SR2.0	Transmit Elastic Store Slip. Set when the elastic store has either repeated or deleted a frame of data.						

IMR1: INTERRUPT MASK REGISTER 1 (Address = 16 Hex)**(MSB)****(LSB)**

RSA1	RDMA	RSA0	RSLIP	RUA1	RRA	RCL	RLOS
------	------	------	-------	------	-----	-----	------

SYMBOL	POSITION	NAME AND DESCRIPTION
RSA1	IMR1.7	Receive Signaling All Ones/Signaling Change 0=interrupt masked 1=interrupt enabled
RDMA	IMR1.6	Receive Distant MF Alarm 0=interrupt masked 1=interrupt enabled
RSA0	IMR1.5	Receive Signaling All Zeros/Signaling Change 0=interrupt masked 1=interrupt enabled
RSLIP	IMR1.4	Receive Elastic Store Slip Occurrence 0=interrupt masked 1=interrupt enabled
RUA1	IMR1.3	Receive Unframed All Ones 0=interrupt masked 1=interrupt enabled
RRA	IMR1.2	Receive Remote Alarm 0=interrupt masked 1=interrupt enabled
RCL	IMR1.1	Receive Carrier Loss 0=interrupt masked 1=interrupt enabled
RLOS	IMR1.0	Receive Loss of Sync 0=interrupt masked 1=interrupt enabled

IMR2: INTERRUPT MASK REGISTER 2 (Address = 17 Hex)

(MSB)				(LSB)			
RMF	RAF	TMF	SEC	TAF	LOTC	RCMF	TSLIP
SYMBOL	POSITION	NAME AND DESCRIPTION					
RMF	IMR2.7	Receive CAS Multiframe 0 = interrupt masked 1 = interrupt enabled					
RAF	IMR2.6	Receive Align Frame 0 = interrupt masked 1 = interrupt enabled					
TMF	IMR2.5	Transmit Multiframe 0 = interrupt masked 1 = interrupt enabled					
SEC	IMR2.4	One Second Timer 0 = interrupt masked 1 = interrupt enabled					
TAF	IMR2.3	Transmit Align Frame 0 = interrupt masked 1 = interrupt enabled					
LOTC	IMR2.2	Loss Of Transmit Clock 0 = interrupt masked 1 = interrupt enabled					
RCMF	IMR2.1	Receive CRC4 Multiframe 0 = interrupt masked 1 = interrupt enabled					
TSLIP	IMR2.0	Transmit Side Elastic Store Slip Occurrence 0 = interrupt masked 1 = interrupt enabled					

12. ERROR COUNT REGISTERS

There are a set of four counters in each framer that record bipolar or code violations, errors in the CRC4 SMF code words, E bits as reported by the far end, and word errors in the FAS. Each of these four counters are automatically updated on either one second boundaries (CCR2.7=0) or every 62.5ms (CCR2.7=1) as determined by the timer in Status Register 2 (SR2.4). Hence, these registers contain performance data from either the previous second or the previous 62.5ms. The user can use the interrupt from the one-second timer to determine when to read these registers. The user has a full second (or 62.5 ms) to read the counters before the data is lost. All four counters will saturate at their respective maximum counts and they will not rollover.

BPV or Code Violation Counter

Violation Count Register 1 (VCR1) is the most significant word and VCR2 is the least significant word of a 16-bit counter that records either BiPolar Violations (BPVs) or Code Violations (CVs). If CCR2.6 = 0, then the VCR counts bipolar violations. Bipolar violations are defined as consecutive marks of the same polarity. In this mode, if the HDB3 mode is set for the receive side by CCR1.2, then HDB3 code words are not counted as BPVs. If CCR2.6 = 1, then the VCR counts code violations as defined in ITU O.161. Code violations are defined as consecutive bipolar violations of the same polarity. In most applications, the framer should be programmed to count BPVs when receiving AMI code and to count CVs when

receiving HDB3 code. This counter increments at all times and is not disabled by loss of sync conditions. The counter saturates at 65,535 and will not rollover. The bit error rate on a E1 line would have to be greater than 10^{*-2} before the VCR would saturate.

VCR1: UPPER BIPOLAR VIOLATION COUNT REGISTER 1 (Address = 00 Hex)

VCR2: LOWER BIPOLAR VIOLATION COUNT REGISTER 2 (Address = 01 Hex)

(MSB)						(LSB)		
V15	V14	V13	V12	V11	V10	V9	V8	VCR1
V7	V6	V5	V4	V3	V2	V1	V0	VCR2

SYMBOL	POSITION	NAME AND DESCRIPTION
V15	VCR1.7	MSB of the 16-bit code violation count
V0	VCR2.0	LSB of the 10-bit code violation count

CRC4 Error Counter

CRC4 Count Register 1 (CRCCR1) is the most significant word and CRCCR2 is the least significant word of a 10-bit counter that records word errors in the Cyclic Redundancy Check 4 (CRC4). Since the maximum CRC4 count in a one second period is 1000, this counter cannot saturate. The counter is disabled during loss of sync at either the FAS or CRC4 level; it will continue to count if loss of multiframe sync occurs at the CAS level.

CRCCR1: CRC4 COUNT REGISTER 1 (Address = 02 Hex)

CRCCR2: CRC4 COUNT REGISTER 2 (Address = 03 Hex)

(MSB)						(LSB)		
*	*	*	*	*	*	CRC9	CRC8	CRCCR1
CRC7	CRC6	CRC5	CRC4	CRC3	CRC2	CRC1	CRC0	CRCCR2

SYMBOL	POSITION	NAME AND DESCRIPTION
CRC9	CRCCR1.1	MSB of the 10-Bit CRC4 error count
CRC0	CRCCR2.0	LSB of the 10-Bit CRC4 error count

*The upper 6 bits of CRCCR1 at address 02 are the most significant bits of the 12-bit FAS error counter.

E-Bit Counter

E-bit Count Register 1 (EBCR1) is the most significant word and EBCR2 is the least significant word of a 10-bit counter that records Far End Block Errors (FEBE) as reported in the first bit of frames 13 and 15 on E1 lines running with CRC4 multiframe. These count registers will increment once each time the received E-bit is set to zero. Since the maximum E-bit count in a one second period is 1000, this counter cannot saturate. The counter is disabled during loss of sync at either the FAS or CRC4 level; it continues to count if loss of multiframe sync occurs at the CAS level.

EBCR1: E-BIT COUNT REGISTER 1 (Address = 04 Hex)

EBCR2: E-BIT COUNT REGISTER 2 (Address = 05 Hex)

(MSB)						(LSB)		
*	*	*	*	*	*	EB9	EB8	EBCR1
EB7	EB6	EB5	EB4	EB3	EB2	EB1	EB0	EBCR2

SYMBOL	POSITION	NAME AND DESCRIPTION
EB9	EBCR1.1	MSB of the 10-Bit E-Bit Error Count
EB0	EBCR2.0	LSB of the 10-Bit E-Bit Error Count

**The upper 6 bits of EBCR1 at address 04 are the least significant bits of the 12-bit FAS error counter.*

FAS Error Counter

FAS Count Register 1 (FASCR1) is the most significant word and FASCR2 is the least significant word of a 12-bit counter that records word errors in the Frame Alignment Signal in timeslot 0. This counter is disabled when RLOS is high. FAS errors are not counted when the framer is searching for FAS alignment and/or synchronization at either the CAS or CRC4 multiframe level. Since the maximum FAS word error count in a one-second period is 4000, this counter cannot saturate.

FASCR1: FAS ERROR COUNT REGISTER 1 (Address = 02 Hex)

FASCR2: FAS ERROR COUNT REGISTER 2 (Address = 04 Hex)

(MSB)						(LSB)		
FAS11	FAS10	FAS9	FAS8	FAS7	FAS6	(Note 2)	(Note 2)	FASCR1
FAS5	FAS4	FAS3	FAS2	FAS1	FAS0	(Note 1)	(Note 1)	FASCR2

SYMBOL	POSITION	NAME AND DESCRIPTION
FAS11	FASCR1.7	MSB of the 12-Bit FAS Error Count
FAS0	FASCR2.2	LSB of the 12-Bit FAS Error Count

NOTES:

- 1) The lower 2 bits of FASCR1 at address 02 are the most significant bits of the 10-bit CRC4 error counter.
- 2) The lower 2 bits of FASCR2 at address 04 are the most significant bits of the 10-bit E-bit counter.

13. DS0 MONITORING FUNCTION

Each framer in the DS21Q44 has the ability to monitor one DS0 64kbps channel in the transmit direction and one DS0 channel in the receive direction at the same time. In the transmit direction, the user determines which channel is to be monitored by properly setting the TCM0 to TCM4 bits in the CCR4 register. In the receive direction, the RCM0 to RCM4 bits in the CCR5 register need to be properly set. The DS0 channel pointed to by the TCM0 to TCM4 bits appear in the Transmit DS0 Monitor (TDS0M) register, and the DS0 channel pointed to by the RCM0 to RCM4 bits appear in the Receive DS0 (RDS0M) register. The TCM4 to TCM0 and RCM4 to RCM0 bits should be programmed with the decimal decode of the appropriate E1 channel. Channels 1–32 map to register values 0 through 31. For example, if DS0 channel 6 (timeslot 5) in the transmit direction and DS0 channel 15 (timeslot 14) in the receive direction needed to be monitored, then the following values would be programmed into CCR4 and CCR5:

TCM4 = 0	RCM4 = 0
TCM3 = 0	RCM3 = 1
TCM2 = 1	RCM2 = 1
TCM1 = 0	RCM1 = 1
TCM0 = 1	RCM0 = 0

CCR4: COMMON CONTROL REGISTER 4 (Address=A8 Hex)

[Repeated here from section 10 for convenience]

(MSB)**(LSB)**

RLB	–	–	TCM4	TCM3	TCM2	TCM1	TCM0
-----	---	---	------	------	------	------	------

SYMBOL	POSITION	NAME AND DESCRIPTION
RLB	CCR4.7	Remote Loopback 0 = loopback disabled 1 = loopback enabled
—	CCR4.6	Not Assigned. Should be set to zero when written.
—	CCR4.5	Not Assigned. Should be set to zero when written.
TCM4	CCR4.4	Transmit Channel Monitor Bit 4. MSB of a channel decode that determines which transmit channel data appears in the TDS0M register (Section 13).
TCM3	CCR4.3	Transmit Channel Monitor Bit 3
TCM2	CCR4.2	Transmit Channel Monitor Bit 2
TCM1	CCR4.1	Transmit Channel Monitor Bit 1
TCM0	CCR4.0	Transmit Channel Monitor Bit 0. LSB of the channel decode

TDS0M: TRANSMIT DS0 MONITOR REGISTER (Address=A9 Hex)**(MSB)****(LSB)**

B1	B2	B3	B4	B5	B6	B7	B8
----	----	----	----	----	----	----	----

SYMBOL	POSITION	NAME AND DESCRIPTION
B1	TDS0M.7	Transmit DS0 Channel Bit 1. MSB of the DS0 channel (first bit to be transmitted).
B2	TDS0M.6	Transmit DS0 Channel Bit 2
B3	TDS0M.5	Transmit DS0 Channel Bit 3
B4	TDS0M.4	Transmit DS0 Channel Bit 4
B5	TDS0M.3	Transmit DS0 Channel Bit 5
B6	TDS0M.2	Transmit DS0 Channel Bit 6
B7	TDS0M.1	Transmit DS0 Channel Bit 7
B8	TDS0M.0	Transmit DS0 Channel Bit 8. LSB of the DS0 channel (last bit to be transmitted).

CCR5: COMMON CONTROL REGISTER 5 (Address = AA Hex)*(Repeated here from Section 10.)*

(MSB)				(LSB)			
—	RESALGN	TESALGN	RCM4	RCM3	RCM2	RCM1	RCM0
SYMBOL	POSITION	NAME AND DESCRIPTION					
—	CCR5.7	Not Assigned. Should be set to zero when written.					
RESALGN	CCR5.6	Receive Elastic Store Align. Setting this bit from a zero to a one may force the receive elastic store's write/read pointers to a minimum separation of half a frame. No action will be taken if the pointer separation is already greater or equal to half a frame. If pointer separation is less than half a frame, the command will be executed and data will be disrupted. Should be toggled after RSYCLK has been applied and is stable. Must be cleared and set again for a subsequent align (Section 17).					
TESALGN	CCR5.5	Transmit Elastic Store Align. Setting this bit from a zero to a one may force the transmit elastic store's write/read pointers to a minimum separation of half a frame. No action will be taken if the pointer separation is already greater or equal to half a frame. If pointer separation is less than half a frame, the command will be executed and data will be disrupted. Should be toggled after TSYCLK has been applied and is stable. Must be cleared and set again for a subsequent align (Section 17).					
RCM4	CCR5.4	Receive Channel Monitor Bit 4. MSB of a channel decode that determines which receive channel data will appear in the RDS0M register (Section 13).					
RCM3	CCR5.3	Receive Channel Monitor Bit 3					
RCM2	CCR5.2	Receive Channel Monitor Bit 2					
RCM1	CCR5.1	Receive Channel Monitor Bit 1					
RCM0	CCR5.0	Receive Channel Monitor Bit 0. LSB of the channel decode.					

RDS0M: RECEIVE DS0 MONITOR REGISTER (Address = AB Hex)**(MSB)****(LSB)**

B1	B2	B3	B4	B5	B6	B7	B8
----	----	----	----	----	----	----	----

SYMBOL	POSITION	NAME AND DESCRIPTION
B1	RDS0M.7	Receive DS0 Channel Bit 1. MSB of the DS0 channel (first bit to be received)
B2	RDS0M.6	Receive DS0 Channel Bit 2
B3	RDS0M.5	Receive DS0 Channel Bit 3
B4	RDS0M.4	Receive DS0 Channel Bit 4
B5	RDS0M.3	Receive DS0 Channel Bit 5
B6	RDS0M.2	Receive DS0 Channel Bit 6
B7	RDS0M.1	Receive DS0 Channel Bit 7
B8	RDS0M.0	Receive DS0 Channel Bit 8. LSB of the DS0 channel (last bit to be received)

14. SIGNALING OPERATION

Each framer in the DS21Q44 contains provisions for both processor based (i.e., software based) signaling bit access and for hardware based access. Both the processor based access and the hardware-based access can be used simultaneously if necessary. The processor based signaling is covered in Section 14.1 and the hardware based signaling is covered in Section 14.2.

14.1. Processor-Based Signaling

The Channel Associated Signaling (CAS) bits embedded in the E1 stream can be extracted from the receive stream and inserted into the transmit stream by the framer. Each of the 30 voice channels has four signaling bits (A/B/C/D) associated with it. The numbers in parenthesis () are the voice channel associated with a particular signaling bit. The voice channel numbers have been assigned as described in the ITU documents. Please note that this is different than the channel numbering scheme (1 to 32) that is used in the rest of the data sheet. For example, voice channel 1 is associated with timeslot 1 (Channel 2) and voice Channel 30 is associated with timeslot 31 (Channel 32). There is a set of 16 registers for the receive side (RS1 to RS16) and 16 registers on the transmit side (TS1 to TS16). The signaling registers are detailed below.

RS1 TO RS16: RECEIVE SIGNALING REGISTERS (Address = 30 to 3F Hex)

(MSB)				(LSB)				
0	0	0	0	X	Y	X	X	
A(1)	B(1)	C(1)	D(1)	A(16)	B(16)	C(16)	D(16)	RS1 (30)
A(2)	B(2)	C(2)	D(2)	A(17)	B(17)	C(17)	D(17)	RS2 (31)
A(3)	B(3)	C(3)	D(3)	A(18)	B(18)	C(18)	D(18)	RS3 (32)
A(4)	B(4)	C(4)	D(4)	A(19)	B(19)	C(19)	D(19)	RS3 (33)
A(5)	B(5)	C(5)	D(5)	A(20)	B(20)	C(20)	D(20)	RS5 (34)
A(6)	B(6)	C(6)	D(6)	A(21)	B(21)	C(21)	D(21)	RS6 (35)
A(7)	B(7)	C(7)	D(7)	A(22)	B(22)	C(22)	D(22)	RS7 (36)
A(8)	B(8)	C(8)	D(8)	A(23)	B(23)	C(23)	D(23)	RS8 (37)
A(9)	B(9)	C(9)	D(9)	A(24)	B(24)	C(24)	D(24)	RS9 (38)
A(10)	B(10)	C(10)	D(10)	A(25)	B(25)	C(25)	D(25)	RS10 (39)
A(11)	B(11)	C(11)	D(11)	A(26)	B(26)	C(26)	D(26)	RS11 (3A)
A(12)	B(12)	C(12)	D(12)	A(27)	B(27)	C(27)	D(27)	RS12 (3B)
A(13)	B(13)	C(13)	D(13)	A(28)	B(28)	C(28)	D(28)	RS13 (3C)
A(14)	B(14)	C(14)	D(14)	A(29)	B(29)	C(29)	D(29)	RS14 (3D)
A(15)	B(15)	C(15)	D(15)	A(30)	B(30)	C(30)	D(30)	RS15 (3E)
								RS16 (3F)

SYMBOL	POSITION	NAME AND DESCRIPTION
X	RS1.0/1/3	Spare Bits
Y	RS1.2	Remote Alarm Bit (integrated and reported in SR1.6)
A(1)	RS2.7	Signaling Bit A for Channel 1
D(30)	RS16.0	Signaling Bit D for Channel 30

Each Receive Signaling Register (RS1 to RS16) reports the incoming signaling from two timeslots. The bits in the Receive Signaling Registers are updated on multiframe boundaries so the user can utilize the Receive Multiframe Interrupt in the Receive Status Register 2 (SR2.7) to know when to retrieve the signaling bits. The user has a full 2ms to retrieve the signaling bits before the data is lost. The RS registers are updated under all conditions. Their validity should be qualified by checking for synchronization at the CAS level. In CCS signaling mode, RS1 to RS16 can also be used to extract signaling information. By the SR2.7 bit, the user will be informed when the signaling registers have been loaded with data. The user has 2ms to retrieve the data before it is lost. The signaling data reported in RS1 to RS16 is also available at the RSIG and RSER pins.

Three status bits in Status Register 1 (SR1) monitor the contents of registers RS1 through RS16. Status monitored includes all zeros detection, all ones detection and a change in register contents. The Receive Signaling All Zeros status bit (SR1.5) is set when over a full multiframe, RS1 through RS16 contain all zeros. The Receive Signaling All Ones status bit (SR1.7) is set when over a full multiframe, RS1 through RS16 contain less than three zeros. A change in the contents of RS1 through RS16 from one multiframe to the next will cause RSA1 (SR1.7) and RSA0 (SR1.5) status bits to be set at the same time.

The user can enable the INT* pin to toggle low upon detection of a change in signaling by setting either the IMR1.7 or IMR1.5 bit. Once a signaling change has been detected, the user has at least 1.75ms to read the data out of the RS1 to RS16 registers before the data will be lost.

TS1 TO TS16: TRANSMIT SIGNALING REGISTERS (Address = 40 to 4F Hex)

(MSB)				(LSB)				
0	0	0	0	X	Y	X	X	
A(1)	B(1)	C(1)	D(1)	A(16)	B(16)	C(16)	D(16)	TS1 (40)
A(2)	B(2)	C(2)	D(2)	A(17)	B(17)	C(17)	D(17)	TS2 (41)
A(3)	B(3)	C(3)	D(3)	A(18)	B(18)	C(18)	D(18)	TS3 (42)
A(4)	B(4)	C(4)	D(4)	A(19)	B(19)	C(19)	D(19)	TS4 (43)
A(5)	B(5)	C(5)	D(5)	A(20)	B(20)	C(20)	D(20)	TS5 (44)
A(6)	B(6)	C(6)	D(6)	A(21)	B(21)	C(21)	D(21)	TS6 (45)
A(7)	B(7)	C(7)	D(7)	A(22)	B(22)	C(22)	D(22)	TS7 (46)
A(8)	B(8)	C(8)	D(8)	A(23)	B(23)	C(23)	D(23)	TS8 (47)
A(9)	B(9)	C(9)	D(9)	A(24)	B(24)	C(24)	D(24)	TS9 (48)
A(10)	B(10)	C(10)	D(10)	A(25)	B(25)	C(25)	D(25)	TS10 (49)
A(11)	B(11)	C(11)	D(11)	A(26)	B(26)	C(26)	D(26)	TS11 (4A)
A(12)	B(12)	C(12)	D(12)	A(27)	B(27)	C(27)	D(27)	TS12 (4B)
A(13)	B(13)	C(13)	D(13)	A(28)	B(28)	C(28)	D(28)	TS13 (4C)
A(14)	B(14)	C(14)	D(14)	A(29)	B(29)	C(29)	D(29)	TS14 (4D)
A(15)	B(15)	C(15)	D(15)	A(30)	B(30)	C(30)	D(30)	TS15 (4E)
								TS16 (4F)

SYMBOL	POSITION	NAME AND DESCRIPTION
X	TS1.0/1/3	Spare Bits
Y	TS1.2	Remote Alarm Bit (integrated and reported in SR1.6)
A(1)	TS2.7	Signaling Bit A for Channel 1
D(30)	TS16.0	Signaling Bit D for Channel 30

Each Transmit Signaling Register (TS1 to TS16) contains the CAS bits for two timeslots that will be inserted into the outgoing stream if enabled to do so by TCR1.5. On multiframe boundaries, the framer will load the values present in the Transmit Signaling Register into an outgoing signaling shift register that is internal to the device. The user can utilize the Transmit Multiframe bit in Status Register 2 (SR2.5) to know when to update the signaling bits. The bit will be set every 2ms and the user has 2ms to update the TSR's before the old data will be retransmitted. ITU specifications recommend that the ABCD signaling not be set to all zeros because they will emulate a CAS multiframe alignment word.

The TS1 register is special because it contains the CAS multiframe alignment word in its upper nibble. The upper nibble must always be set to 0000 or else the terminal at the far end will lose multiframe synchronization. If the user wishes to transmit a multiframe alarm to the far end, then the TS1.2 bit should be set to a one. If no alarm is to be transmitted, then the TS1.2 bit should be cleared. The three remaining bits in TS1 are the spare bits. If they are not used, they should be set to one. In CCS signaling mode, TS1 to TS16 can also be used to insert signaling information. By the SR2.5 bit, the user will be informed when the signaling registers need to be loaded with data. The user has 2 ms to load the data before the old data will be retransmitted.

By the CCR3.6 bit, the user has the option to use the Transmit Channel Blocking Registers (TCBRs) to determine on a channel by channel basis, which signaling bits are to be inserted by the TSRs (the corresponding bit in the TCBRs = 1) and which are to be sourced from the TSER or TSIG pin (the corresponding bit in the TCBRs = 0). See the Transmit Data Flow diagram in Section 22 for more details.

14.2. Hardware-Based Signaling

Receive Side

In the receive side of the hardware based signaling, there are two operating modes for the signaling buffer; signaling extraction and signaling re-insertion. Signaling extraction involves pulling the signaling bits from the receive data stream and buffering them over a four multiframe buffer and outputting them in a serial PCM fashion on a channel-by-channel basis at the RSIG output. This mode is always enabled. In this mode, the receive elastic store may be enabled or disabled. If the receive elastic store is enabled, then the backplane clock (RSYSCLK) must be 2.048 MHz. The ABCD signaling bits are output on RSIG in the lower nibble of each channel. The RSIG data is updated once a multiframe (2 ms) unless a freeze is in effect. See the timing diagrams in Section 22 for some examples.

The other hardware based signaling operating mode called signaling re-insertion can be invoked by setting the RSRE control bit high (CCR3.3=1). In this mode, the user will provide a multiframe sync at the RSYNC pin and the signaling data be re-aligned at the RSER output according to this applied multiframe boundary in this mode, the elastic store must be enabled the backplane clock must be 2.048 MHz.

The signaling data in the two multiframe buffer will be frozen in a known good state upon either a loss of synchronization (OOF event), carrier loss, or frame slip. To allow this freeze action to occur, the RFE control bit (CCR2.0) should be set high. The user can force a freeze by setting the RFF control bit (CCR2.1) high. Setting the RFF bit high causes the same freezing action as if a loss of synchronization, carrier loss, or slip has occurred.

The 2 multiframe buffer provides an approximate 1 multiframe delay in the signaling bits provided at the RSIG pin (and at the RSER pin if RSRE=1 by CCR3.3). When freezing is enabled (RFE=1), the signaling data will be held in the last known good state until the corrupting error condition subsides. When the error condition sub-sides, the signaling data will be held in the old state for an additional 3 ms to 5 ms before being allowed to be updated with new signaling data.

Transmit Side

By the THSE control bit (CCR3.2), the DS21Q44 can be set up to take the signaling data presented at the TSIG pin and insert the signaling data into the PCM data stream that is being input at the TSER pin. The hardware signaling insertion capabilities of each framer are available whether the transmit side elastic store is enabled or disabled. If the transmit side elastic store is enabled, the backplane clock (TSYSCLK) must be 2.048 MHz.

When hardware signaling insertion is enabled on a framer (THSE=1), then the user must enable the Transmit Channel Blocking Register Function Select (TCBFS) control bit (CCR3.6=1). This is needed so that the CAS multiframe alignment word, multiframe remote alarm, and spare bits can be added to timeslot 16 in frame 0 of the multiframe. The TS1 register should be programmed with the proper information. If CCR3.6=1, then a zero in the TCBRS implies that signaling data is to be sourced from TSER (or TSIG if CCR3.2=1) and a one implies that signaling data for that channel is to be sourced from the Transmit Signaling (TS) registers. See definition below.

TCBR1/TCBR2/TCBR3/TCBR4: DEFINITION WHEN CCR3.6 = 1

(MSB)

(LSB)

CH20	CH4	CH19	CH3	CH18	CH2	CH17*	CH1*	TCBR1(22)
CH24	CH8	CH23	CH7	CH22	CH6	CH21	CH5	TCBR2(23)
CH28	CH12	CH27	CH11	CH26	CH10	CH25	CH9	TCBR3(24)
CH32	CH16	CH31	CH15	CH30	CH14	CH29	CH13	TCBR4(25)

*CH1 and CH17 should be set to one to allow the internal TS1 register to create the CAS Multiframe Alignment Word and Spare/Remote Alarm bits.

The user can also take advantage of this functionality to intermix signaling data from the TSIG pin and from the internal Transmit Signaling Registers (TS1 to TS16). As an example, assume that the user wishes to source all the signaling data except for voice channels 5 and 10 from the TSIG pin. In this application, the following bits and registers would be programmed as follows:

CONTROL BITS	REGISTER VALUES
THSE = 1 (CCR3.2)	TS1 = 0Bh (MF alignment word, remote alarm etc.)
TCBFS = 1 (CCR3.6)	TCBR1 = 03h (source timeslot 16, frame 1 data)
T16S = 1(TCR1.5)	TCBR2 = 01h (source voice Channel 5 signaling data from TS6)
	TCBR3 = 04h (source voice Channel 10 signaling data from TS11)
	TCBR4 = 00h

15. PER-CHANNEL CODE GENERATION AND LOOPBACK

Each framer in the DS21Q44 can replace data on a channel-by-channel basis in both the transmit and receive directions. The transmit direction is from the backplane to the E1 line and is covered in Section 15.1. The receive direction is from the E1 line to the backplane and is covered in Section 15.2.

15.1. Transmit Side Code Generation

In the transmit direction there are two methods by which channel data from the backplane can be overwritten with data generated by the framer. The first method which is covered in Section 15.1.1 was a feature contained in the original DS21Q43 while the second method which is covered in Section 15.1.2 is a new feature of the DS21Q44.

15.1.1. Simple Idle Code Insertion and Per-Channel Loopback

The first method involves using the Transmit Idle Registers (TIR1/2/3/4) to determine which of the 32 E1 channels should be overwritten with the code placed in the Transmit Idle Definition Register (TIDR). This method allows the same 8-bit code to be placed into any of the 32 E1 channels. If this method is used, then the CCR3.5 control bit must be set to zero.

Each of the bit position in the Transmit Idle Registers (TIR1/TIR2/TIR3/TIR4) represent a DS0 channel in the outgoing frame. When these bits are set to a one, the corresponding channel will transmit the Idle Code contained in the Transmit Idle Definition Register (TIDR).

The Transmit Idle Registers (TIRs) have an alternate function that allow them to define a Per-Channel LoopBack (PCLB). If the TIRFS control bit (CCR3.5) is set to one, then the TIRs will determine which channels (if any) from the backplane should be replaced with the data from the receive side or in other words, off of the E1 line. If this mode is enabled, then transmit and receive clocks and frame syncs must be synchronized. One method to accomplish this would be to tie RCLK to TCLK and RFSYNC to TSYNC. There are no restrictions on which channels can be looped back or on how many channels can be looped back.

TIR1/TIR2/TIR3: TRANSMIT IDLE REGISTERS (Address = 26 to 29 Hex)

(Also used for Per-Channel Loopback)

(MSB)				(LSB)				
CH8	CH7	CH6	CH5	CH4	CH3	CH2	CH1	TIR1 (26)
CH16	CH15	CH14	CH13	CH12	CH11	CH10	CH9	TIR2 (27)
CH24	CH23	CH22	CH21	CH20	CH19	CH18	CH17	TIR3 (28)
CH32	CH31	CH30	CH29	CH28	CH27	CH26	CH25	TIR4 (29)

SYMBOL	POSITION	NAME AND DESCRIPTION
CH1 –32	TIR1.0–4.7	Transmit Idle Code Insertion Control Bits 0 = do not insert the Idle Code in the TIDR into this channel 1 = insert the Idle Code in the TIDR into this channel

Note: If CCR3.5 = 1, then a 0 in the TIRs implies that channel data is to be sourced from TSER and a one implies that channel data is to be sourced from the output of the receive side framer (i.e., Per-Channel Loopback; see Figure 6–1).

TIDR: TRANSMIT IDLE DEFINITION REGISTER (Address = 2A Hex)

(MSB)							(LSB)
TIDR7	TIDR6	TIDR5	TIDR4	TIDR3	TIDR2	TIDR1	TIDR0

SYMBOL	POSITION	NAME AND DESCRIPTION
TIDR7	TIDR.7	MSB of the Idle Code (this bit is transmitted first)
TIDR0	TIDR.0	LSB of the Idle Code (this bit is transmitted last)

15.1.2. Per-Channel Code Insertion

The second method involves using the Transmit Channel Control Registers (TCC1/2/3/4) to determine which of the 32 E1 channels should be overwritten with the code placed in the Transmit Channel Registers (TC1 to TC32). This method is more flexible than the first in that it allows a different 8-bit code to be placed into each of the 32 E1 channels.

TC1 TO TC32: TRANSMIT CHANNEL REGISTERS (Address = 60 to 7F Hex)*(for brevity, only channel one is shown; see Table 8-1 for other register address)*

(MSB)	C7	C6	C5	C4	C3	C2	C1	(LSB)	TC1 (60)
--------------	----	----	----	----	----	----	----	--------------	----------

SYMBOL	POSITION	NAME AND DESCRIPTION
C7	TC1.7	MSB of the Code (this bit is transmitted first)
C0	TC1.0	LSB of the Code (this bit is transmitted last)

TCC1/TCC2/TCC3/TCC4: TRANSMIT CHANNEL CONTROL REGISTER (Address = A0 to A3 Hex)

(MSB)	CH8	CH7	CH6	CH5	CH4	CH3	CH2	(LSB)	TCC1 (A0)
	CH16	CH15	CH14	CH13	CH12	CH11	CH10	CH9	TCC2 (A1)
	CH24	CH23	CH22	CH21	CH20	CH19	CH18	CH17	TCC3 (A2)
	CH32	CH31	CH30	CH29	CH28	CH27	CH26	CH25	TCC4 (A3)

SYMBOL	POSITION	NAME AND DESCRIPTION
CH1–32	TCC1.0–4.7	Transmit Code Insertion Control Bits 0 = do not insert data from the TC register into the transmit data stream 1 = insert data from the TC register into the transmit data stream

15.2. Receive Side Code Generation

On the receive side, the Receive Channel Control Registers (RCC1/2/3/4) are used to determine which of the 32 E1 channels off of the E1 line and going to the backplane should be overwritten with the code placed in the Receive Channel Registers (RC1 to RC32). This method allows a different 8-bit code to be placed into each of the 32 E1 channels.

RC1 TO RC32: RECEIVE CHANNEL REGISTERS (Address = 80 to 9F Hex)*(For brevity, only channel one is shown; see Table 8-1 for other register address)*

(MSB)	C7	C6	C5	C4	C3	C2	C1	(LSB)	RC1 (80)
--------------	----	----	----	----	----	----	----	--------------	----------

SYMBOL	POSITION	NAME AND DESCRIPTION
C7	RC1.7	MSB of the Code (this bit is sent first to the backplane)
C0	RC1.0	LSB of the Code (this bit is sent last to the backplane)

RCC1/RCC2/RCC3/RCC4: RECEIVE CHANNEL CONTROL REGISTER (Address = A4 to A7 Hex)

(MSB)				(LSB)				
CH8	CH7	CH6	CH5	CH4	CH3	CH2	CH1	RCC1 (A4)
CH16	CH15	CH14	CH13	CH12	CH11	CH10	CH9	RCC2 (A5)
CH24	CH23	CH22	CH21	CH20	CH19	CH18	CH17	RCC3 (A6)
CH32	CH31	CH30	CH29	CH28	CH27	CH26	CH25	RCC4 (A7)

SYMBOL	POSITION	NAME AND DESCRIPTION
CH1–32	RCC1.0–4.7	Receive Code Insertion Control Bits 0 = do not insert data from the RC register into the receive data stream 1 = insert data from the RC register into the receive data stream

16. CLOCK BLOCKING REGISTERS

The Receive Channel blocking Registers (RCBR1/RCBR2/RCBR3/RCBR4) and the Transmit Channel Blocking Registers (TCBR1/TCBR2/TCBR3/TCBR4) control RCHBLK and TCHBLK pins respectively. (The RCHBLK and TCHBLK pins are user programmable outputs that can be forced either high or low during individual channels). These outputs can be used to block clocks to a USART or LAPD controller in ISDN–PRI applications. When the appropriate bits are set to a one, the RCHBLK and TCHBLK pin will be held high during the entire corresponding channel time. See the timing in Section 22 for an example. The TCBRs have alternate mode of use. By the CCR3.6 bit, the user has the option to use the TCBRs to determine on a channel by channel basis, which signaling bits are to be inserted by the TSRs (the corresponding bit in the TCBRs = 1) and which are to be sourced from the TSER or TSIG pins (the corresponding bit in the TCBR = 0). See the timing in Section 22 for an example.

RCBR1/RCBR2/RCBR3/RCBR4: RECEIVE CHANNEL BLOCKING REGISTERS (Address = 2B to 2E Hex)

(MSB)				(LSB)				
CH8	CH7	CH6	CH5	CH4	CH3	CH2	CH1	RCBR1 (2B)
CH16	CH15	CH14	CH13	CH12	CH11	CH10	CH9	RCBR2 (2C)
CH24	CH23	CH22	CH21	CH20	CH19	CH18	CH17	RCBR3 (2D)
CH32	CH31	CH30	CH29	CH28	CH27	CH26	CH25	RCBR4 (2E)

SYMBOL	POSITION	NAME AND DESCRIPTION
CH1–32	RCBR1.0–4.7	Receive Channel Blocking Control Bits 0 = force the RCHBLK pin to remain low during this channel time 1 = force the RCHBLK pin high during this channel time

TCBR1/TCBR2/TCBR3/TCBR4: TRANSMIT CHANNEL BLOCKING REGISTERS (Address = 22 to 25 Hex)

(MSB)				(LSB)				
CH8	CH7	CH6	CH5	CH4	CH3	CH2	CH1	TCBR1 (22)
CH16	CH15	CH14	CH13	CH12	CH11	CH10	CH9	TCBR2 (23)
CH24	CH23	CH22	CH21	CH20	CH19	CH18	CH17	TCBR3 (24)
CH32	CH31	CH30	CH29	CH28	CH27	CH26	CH25	TCBR4 (25)

SYMBOL	POSITION	NAME AND DESCRIPTION
CH1-32	TCBR1.0-4.7	Transmit Channel Blocking Control Bits 0 = force the TCHBLK pin to remain low during this channel time 1 = force the TCHBLK pin high during this channel time

Note: If CCR3.6 = 1, then a zero in the TCBRs implies that signaling data is to be sourced from TSER (or TSIG if CCR3.2 = 1) and a one implies that signaling data for that channel is to be sourced from the Transmit Signaling (TS) registers. See definition below.

TCBR1/TCBR2/TCBR3/TCBR4: DEFINITION WHEN CCR3.6 = 1

(MSB)				(LSB)				
CH20	CH4	CH19	CH3	CH18	CH2	CH17*	CH1*	TCBR1 (22)
CH24	CH8	CH23	CH7	CH22	CH6	CH21	CH5	TCBR2 (23)
CH28	CH12	CH27	CH11	CH26	CH10	CH25	CH9	TCBR3 (24)
CH32	CH16	CH31	CH15	CH30	CH14	CH29	CH13	TCBR4 (25)

*CH1 and CH17 should be set to one to allow the internal TS1 register to create the CAS Multiframe Alignment Word and Spare/Remote Alarm bits.

17. ELASTIC STORES OPERATION

Each framer in the DS21Q44 contains dual two-frame (512 bits) elastic stores, one for the receive direction, and one for the transmit direction. These elastic stores have two main purposes. First, they can be used to rate convert the E1 data stream to 1.544Mbps (or a multiple of 1.544Mbps), which is the T1 rate. Secondly, they can be used to absorb the differences in frequency and phase between the E1 data stream and an asynchronous (i.e., not frequency locked) backplane clock, which can be 1.544MHz or 2.048MHz. The backplane clock can burst at rates up to 8.192MHz. Both elastic stores contain full controlled slip capability, which is necessary for this second purpose. Both elastic stores within a framer are fully independent and no restrictions apply to the sourcing of the various clocks that are applied to them. The transmit side elastic store can be enabled whether the receive elastic store is enabled or disabled and vice versa. Also, each elastic store can interface to either a 1.544MHz or 2.048MHz backplane without regard to the backplane rate the other elastic store is interfacing.

Two mechanisms are available to the user for resetting the elastic stores. The Elastic Store Reset (CCR6.0 and CCR6.1) function forces the elastic stores to a depth of one frame unconditionally. Data is lost during the reset. The second method, the Elastic Store Align (CCR5.5 and CCR5.6) forces the elastic store depth to a minimum depth of half a frame only if the current pointer separation is already less than half a frame. If a realignment occurs data is lost. In both mechanisms, independent resets are provided for both the receive and transmit elastic stores.

17.1. Receive Side

If the receive side elastic store is enabled (RCR2.1=1), then the user must provide either a 1.544MHz (RCR2.2 =0) or 2.048MHz (RCR2.2=1) clock at the RSYSCLK pin. The user has the option of either providing a frame/multiframe sync at the RSYNC pin (RCR1.5=1) or having the RSYNC pin provide a pulse on frame/multiframe boundaries (RCR1.5=0). If the user wishes to obtain pulses at the frame boundary, then RCR1.6 must be set to zero and if the user wishes to have pulses occur at the multiframe boundary, then RCR1.6 must be set to one. The DS21Q44 will always indicate frame boundaries by the RFSYNC output whether the elastic store is enabled or not. If the elastic store is enabled, then either CAS (RCR1.7=0) or CRC4 (RCR1.7=1) multiframe boundaries will be indicated by the RMSYNC output. If the user selects to apply a 1.544MHz clock to the RSYSCLK pin, then every fourth channel of the received E1 data is deleted and an F-bit position (which will be forced to one) is inserted. Hence, Channels 1, 5, 9, 13, 17, 21, 25, and 29 (timeslots 0, 4, 8, 12, 16, 20, 24, and 28) will be deleted from the received E1 data stream. Also, in 1.544MHz applications, the RCHBLK output will not be active in Channels 25 through 32 (or in other words, RCBR4 is not active). See Section 22 for timing details. If the 512-bit elastic buffer either fills or empties, a controlled slip will occur. If the buffer empties, then a full frame of data (256 bits) will be repeated at RSER and the SR1.4 and RIR.3 bits will be set to a one. If the buffer fills, then a full frame of data will be deleted and the SR1.4 and RIR.4 bits will be set to a one.

17.2. Transmit Side

The operation of the transmit elastic store is very similar to the receive side. The transmit side elastic store is enabled by CCR3.7. A 1.544MHz (CCR3.1=0) or 2.048MHz (CCR3.1=1) clock can be applied to the TSYCLK input. The TSYCLK can be a bursty clock with rates up to 8.192MHz. If the user selects to apply a 1.544MHz clock to the TSYCLK pin, then the data sampled at TSER will be ignored every fourth channel. Hence, Channels 1, 5, 9, 13, 17, 21, 25, and 29 (timeslots 0, 4, 8, 12, 16, 20, 24, and 28) are ignored. The user must supply an 8kHz frame sync pulse to the TSSYNC input. See Section 22 for timing details. Controlled slips in the transmit elastic store are reported in the SR2.0 bit and the direction of the slip is reported in the RIR.6 and RIR.7 bits.

18. ADDITIONAL (Sa) AND INTERNATIONAL (Si) BIT OPERATION

Each framer in the DS21Q44 provides for access to both the Sa and the Si bits by three different methods. The first is by a hardware scheme using the RLINK/RLCLK and TLINK/ TLCLK pins. The first method is discussed in Section 18.1. The second involves using the internal RAF/RNAF and TAF/TNAF registers and is discussed in Section 18.2. The third method which is covered in Section 18.3 involves an expanded version of the second method and is one of the features added to the DS21Q44 from the original DS21Q43 definition.

18.1. Hardware Scheme

On the receive side, all of the received data is reported at the RLINK pin. Through RCR2, the user can control the RLCLK pin to pulse during any combination of Sa bits. This allows the user to create a clock that can be used to capture the needed Sa bits. If RSYNC is programmed to output a frame boundary, it will identify the Si bits. See Section 22 for detailed timing.

On the transmit side, the individual Sa bits can be either sourced from the internal TNAF register (see Section 18.2 for details) or from the external TLINK pin. Through TCR2, the framer can be programmed to source any combination of the additional bits from the TLINK pin. If the user wishes to pass the Sa bits through the framer without them being altered, then the device should be set up to source all five Sa bits by the TLINK pin and the TLINK pin should be connected to the TSER pin. Si bits can be inserted through the TSER pin by the clearing of the TCR1.3 bit. See the timing diagrams and the transmit data flow diagram in Section 22 for examples.

18.2. Internal Register Scheme Based On Double-Frame

On the receive side, the RAF and RNAF registers will always report the data as it received in the Additional and International bit locations. The RAF and RNAF registers are updated with the setting of the Receive Align Frame bit in Status Register 2 (SR2.6). The host can use the SR2.6 bit to know when to read the RAF and RNAF registers. It has 250 μ s to retrieve the data before it is lost.

On the transmit side, data is sampled from the TAF and TNAF registers with the setting of the Transmit Align Frame bit in Status Register 2 (SR2.3). The host can use the SR2.3 bit to know when to update the TAF and TNAF registers. It has 250 μ s to update the data or else the old data will be retransmitted. Data in the Si bit position will be overwritten if the framer is programmed: (1) to source the Si bits from the TSER pin, (2) in the CRC4 mode, or (3) have automatic E-bit insertion enabled. Data in the Sa bit position will be overwritten if any of the TCR2.3 to TCR2.7 bits are set to one (please see Section 18.1 for details). For more details, see the register descriptions for TCR1 and TCR2 and the transmit data flow diagram in Section 18.

RAF: RECEIVE ALIGN FRAME REGISTER (Address = 2F Hex)

(MSB)				(LSB)			
Si	0	0	1	1	0	1	1

SYMBOL	POSITION	NAME AND DESCRIPTION
Si	RAF.7	International Bit
0	RAF.6	Frame Alignment Signal Bit
0	RAF.5	Frame Alignment Signal Bit
1	RAF.4	Frame Alignment Signal Bit
1	RAF.3	Frame Alignment Signal Bit
0	RAF.2	Frame Alignment Signal Bit
1	RAF.1	Frame Alignment Signal Bit
1	RAF.0	Frame Alignment Signal Bit

RNAF: RECEIVE NON-ALIGN FRAME REGISTER (Address = 1F Hex)

(MSB)				(LSB)			
Si	1	A	Sa4	Sa5	Sa6	Sa7	Sa8

SYMBOL	POSITION	NAME AND DESCRIPTION
Si	RNAF.7	International Bit
1	RNAF.6	Frame Non-Alignment Signal Bit
A	RNAF.5	Remote Alarm
Sa4	RNAF.4	Additional Bit 4
Sa5	RNAF.3	Additional Bit 5
Sa6	RNAF.2	Additional Bit 6
Sa7	RNAF.1	Additional Bit 7
Sa8	RNAF.0	Additional Bit 8

TAF: TRANSMIT ALIGN FRAME REGISTER (Address = 20 Hex)**(MSB)****(LSB)**

Si	0	0	1	1	0	1	1
----	---	---	---	---	---	---	---

(Must be programmed with the 7-bit FAS word; the DS21Q44 does not automatically set these bits.)

SYMBOL	POSITION	NAME AND DESCRIPTION
Si	TAF.7	International Bit
0	TAF.6	Frame Alignment Signal Bit
0	TAF.5	Frame Alignment Signal Bit
1	TAF.4	Frame Alignment Signal Bit
1	TAF.3	Frame Alignment Signal Bit
0	TAF.2	Frame Alignment Signal Bit
1	TAF.1	Frame Alignment Signal Bit
1	TAF.0	Frame Alignment Signal Bit

TNAF: TRANSMIT NON-ALIGN FRAME REGISTER (Address = 21 Hex)**(MSB)****(LSB)**

Si	1	A	Sa4	Sa5	Sa6	Sa7	Sa8
----	---	---	-----	-----	-----	-----	-----

(Bit 2 must be programmed to one; the DS21Q44 does not automatically set this bit.)

SYMBOL	POSITION	NAME AND DESCRIPTION
Si	TNAF.7	International Bit
1	TNAF.6	Frame Non-Alignment Signal Bit
A	TNAF.5	Remote Alarm (used to transmit the alarm)
Sa4	TNAF.4	Additional Bit 4
Sa5	TNAF.3	Additional Bit 5
Sa6	TNAF.2	Additional Bit 6
Sa7	TNAF.1	Additional Bit 7
Sa8	TNAF.0	Additional Bit 8

18.3. Internal Register Scheme Based On CRC4 Multiframe

On the receive side, there is a set of eight registers (RSiAF, RSiNAF, RRA, RSa4 to RSa8) that report the Si and Sa bits as they are received. These registers are updated with the setting of the Receive CRC4 Multiframe bit in Status Register 2 (SR2.1). The host can use the SR2.1 bit to know when to read these registers. The user has 2ms to retrieve the data before it is lost. The MSB of each register is the first received. Please see the register descriptions below and the Transmit Data Flow diagram in Section 22 for more details. On the transmit side, there is also a set of eight registers (TSiAF, TSiNAF, TRA, TSa4 to TSa8) that by the Transmit Sa Bit Control Register (TSaCR), can be programmed to insert both Si and Sa data. Data is sampled from these registers with the setting of the Transmit Multiframe bit in Status Register 2 (SR2.5). The host can use the SR2.5 bit to know when to update these registers. It has 2ms to update the data or else the old data will be retransmitted. The MSB of each register is the first bit transmitted. Please see the register descriptions below and the Transmit Data Flow diagram in Section 22 for more details.

REGISTER	ADDRESS (HEX)	FUNCTION
RSiAF	58	The eight Si bits in the align frame.
RSiNAF	59	The eight Si bits in the non-align frame.
RRA	5A	The eight reportings of the receive remote alarm (RA).
RSa4	5B	The eight Sa4 reported in each CRC4 multiframe.
RSa5	5C	The eight Sa5 reported in each CRC4 multiframe.
RSa6	5D	The eight Sa6 reported in each CRC4 multiframe.
RSa7	5E	The eight Sa7 reported in each CRC4 multiframe.
RSa8	5F	The eight Sa8 reported in each CRC4 multiframe.
TSiAF	50	The eight Si bits to be inserted into the align frame.
TSiNAF	51	The eight Si bits to be inserted into the non-align frame.
TRA	52	The eight settings of remote alarm (RA).
TSa4	53	The eight Sa4 settings in each CRC4 multiframe.
TSa5	54	The eight Sa5 settings in each CRC4 multiframe.
TSa6	55	The eight Sa6 settings in each CRC4 multiframe.
TSa7	56	The eight Sa7 settings in each CRC4 multiframe.
TSa8	57	The eight Sa8 settings in each CRC4 multiframe.

TSaCR: TRANSMIT Sa BIT CONTROL REGISTER (Address = 1C Hex)**(MSB)****(LSB)**

SiAF	SiNAF	RA	Sa4	Sa5	Sa6	Sa7	Sa8
------	-------	----	-----	-----	-----	-----	-----

SYMBOL	POSITION	NAME AND DESCRIPTION
SiAF	TSaCR.7	International Bit in Align Frame Insertion Control Bit 0 = do not insert data from the TSiAF register into the transmit data stream 1 = insert data from the TSiAF register into the transmit data stream
SiNAF	TSaCR.6	International Bit in Non-Align Frame Insertion Control Bit 0 = do not insert data from the TSiNAF register into the transmit data stream 1 = insert data from the TSiNAF register into the transmit data stream
RA	TSaCR.5	Remote Alarm Insertion Control Bit 0 = do not insert data from the TRA register into the transmit data stream 1 = insert data from the TRA register into the transmit data stream
Sa4	TSaCR.4	Additional Bit 4 Insertion Control Bit 0 = do not insert data from the TSa4 register into the transmit data stream 1 = insert data from the TSa4 register into the transmit data stream
Sa5	TSaCR.3	Additional Bit 5 Insertion Control Bit 0 = do not insert data from the TSa5 register into the transmit data stream 1 = insert data from the TSa5 register into the transmit data stream
Sa6	TSaCR.2	Additional Bit 6 Insertion Control Bit 0 = do not insert data from the TSa6 register into the transmit data stream 1 = insert data from the TSa6 register into the transmit data stream
Sa7	TSaCR.1	Additional Bit 7 Insertion Control Bit 0 = do not insert data from the TSa7 register into the transmit data stream 1 = insert data from the TSa7 register into the transmit data stream
Sa8	TSaCR.0	Additional Bit 8 Insertion Control Bit 0 = do not insert data from the TSa8 register into the transmit data stream 1 = insert data from the TSa8 register into the transmit data stream

19. HDLC Controller for the Sa Bits or DS0

Each framer in the DS21Q44 has the ability to extract/insert data from/ into the Sa bit positions (Sa4 to Sa8) or from/to any multiple of DS0 channels. Each framer contains a complete HDLC controller and this operation is covered in Section 19.1.

19.1. General Overview

Each framer contains a complete HDLC controller with 64-byte buffers in both the transmit and receive directions. The HDLC controller performs all the necessary overhead for generating and receiving a HDLC formatted message.

The HDLC controller automatically generates and detects flags, generates and checks the CRC check sum, generates and detects abort sequences, stuffs and destuffs zeros (for transparency), and byte aligns to the HDLC data stream.

There are eleven registers that the host will use to operate and control the operation of the HDLC controller. A brief description of the registers is shown in Table 19-1.

Table 19-1. HDLC CONTROLLER REGISTER LIST

NAME	FUNCTION
HDLC Control Register (HCR)	General control over the HDLC controller
HDLC Status Register (HSR)	Key status information for both transmit and receive directions
HDLC Interrupt Mask Register (HIMR)	Allows/stops status bits to/from causing an interrupt
Receive HDLC Information Register (RHIR)	Status information on receive HDLC controller
Receive HDLC FIFO Register (RHFR)	Access to 64-byte HDLC FIFO in receive direction
Receive HDLC DS0 Control Register 1 (RDC1) Receive HDLC DS0 Control Register 2 (RDC2)	Controls the HDLC function when used on DS0 channels
Transmit HDLC Information Register (THIR)	Status information on transmit HDLC controller
Transmit HDLC FIFO Register (THFR)	Access to 64-byte HDLC FIFO in transmit direction
Transmit HDLC DS0 Control Register 1 (TDC1) Transmit HDLC DS0 Control Register 2 (TDC2)	Controls the HDLC function when used on DS0 channels

19.2. HDLC Status Registers

Three of the HDLC controller registers (HSR, RHIR, and THIR) provide status information. When a particular event has occurred (or is occurring), the appropriate bit in one of these three registers will be set to a one. Some of the bits in these three status registers are latched and some are real time bits that are not latched. Section 19.4 contains register descriptions that list which bits are latched and which are not. With the latched bits, when an event occurs and a bit is set to a one, it will remain set until the user reads that bit. The bit will be cleared when it is read and it will not be set again until the event has occurred again. The real time bits report the current instantaneous conditions that are occurring and the history of these bits is not latched.

Like the other status registers in the framer, the user will always proceed a read of any of the three registers with a write. The byte written to the register will inform the framer which of the latched bits the user wishes to read and have cleared (the real time bits are not affected by writing to the status register). The user will write a byte to one of these registers, with a one in the bit positions he or she wishes to read and a zero in the bit positions he or she does not wish to obtain the latest information on. When a one is written to a bit location, the read register will be updated with current value and it will be cleared. When a zero is written to a bit position, the read register will not be updated and the previous value will be held. A write to the status and information registers will be immediately followed by a read of the same

register. The read result should be logically AND'ed with the mask byte that was just written and this value should be written back into the same register to insure that bit does indeed clear. This second write step is necessary because the alarms and events in the status registers occur asynchronously in respect to their access by the parallel port. This write-read-write (for polled-driven access) or write-read (for interrupt driven access) scheme allows an external microcontroller or microprocessor to individually poll certain bits without disturbing the other bits in the register. This operation is key in controlling the DS21Q44 with higher order software languages.

Like the SR1 and SR2 status registers, the HSR register has the unique ability to initiate a hardware interrupt by the INT* output pin. Each of the events in the HSR can be either masked or unmasked from the interrupt pin by the HDLC Interrupt Mask Register (HIMR). Interrupts will force the INT* pin low when the event occurs. The INT* pin will be allowed to return high (if no other interrupts are present) when the user reads the event bit that caused the interrupt to occur.

19.3. BASIC OPERATION DETAILS

As a basic guideline for interpreting and sending HDLC messages, the following sequences can be applied:

Receive a HDLC Message

- 1) Enable RPS interrupts.
- 2) Wait for interrupt to occur.
- 3) Disable RPS interrupt and enable either RPE, RNE, or RHALF interrupt.
- 4) Read RHIR to obtain REMPTY status.
 - a) If REMPTY = 0, then record OBYTE, CBYTE, and POK bits and then read the FIFO
 - a1) If CBYTE = 0 then skip to Step 5
 - a2) If CBYTE = 1 then skip to Step 7
 - b) If REMPTY = 1, then skip to Step 6
- 5) Repeat Step 4.
- 6) Wait for interrupt, skip to Step 4.
- 7) If POK = 0, then discard whole packet, if POK = 1, accept the packet.
- 8) Disable RPE, RNE, or RHALF interrupt, enable RPS interrupt and return to Step 1.

Transmit a HDLC Message

- 1) Make sure HDLC controller is done sending any previous messages and is current sending flags by checking that the FIFO is empty by reading the TEMPTY status bit in the THIR register.
- 2) Enable either the THALF or TNF interrupt.
- 3) Read THIR to obtain TFULL status.
 - a) If TFULL = 0, then write a byte into the FIFO and skip to next step (special case occurs when the last byte is to be written, in this case set TEOM = 1 before writing the byte and then skip to Step 6)
 - b) If TFULL = 1, then skip to Step 5
- 4) Repeat Step 3.
- 5) Wait for interrupt, skip to Step 3.
- 6) Disable THALF or TNF interrupt and enable TMEND interrupt.
- 7) Wait for an interrupt, then read TUDR status bit to make sure packet was transmitted correctly.

19.4. HDLC REGISTER DESCRIPTION

HCR: HDLC CONTROL REGISTER (Address=B0 Hex)

(MSB)

(LSB)

—	RHR	TFS	THR	TABT	TEOM	TZSD	TCRCD
---	-----	-----	-----	------	------	------	-------

SYMBOL	POSITION	NAME AND DESCRIPTION
—	HCR.7	Not Assigned. Should be set to zero.
RHR	HCR.6	Receive HDLC Reset. A 0-to-1 transition resets the receive HDLC controller. Must be cleared and set again for a subsequent reset.
TFS	HCR.5	Transmit Flag/Idle Select 0 = 7Eh. 1 = FFh.
THR	HCR.4	Transmit HDLC Reset. A 0-to-1 transition resets the transmit HDLC controller. Must be cleared and set again for a subsequent reset.
TABT	HCR.3	Transmit Abort. A 0-to-1 transition causes the FIFO contents to be dumped and one FEh abort to be sent followed by 7Eh or FFh flags/idle until a new packet is initiated by writing new data into the FIFO. Must be cleared and set again for a subsequent abort to be sent.
TEOM	HCR.2	Transmit End of Message. Should be set to a one just before the last data byte of a HDLC packet is written into the transmit FIFO at THFR. The HDLC controller will clear this bit when the last byte has been transmitted.
TZSD	HCR.1	Transmit Zero Stuffer Defeat. Overrides internal enable. 0 = enable the zero stuffer (normal operation) 1 = disable the zero stuffer
TCRCD	HCR.0	Transmit CRC Defeat 0 = enable CRC generation (normal operation) 1 = disable CRC generation

HSR: HDLC STATUS REGISTER (Address = B1 Hex)**(MSB)****(LSB)**

—	RPE	RPS	RHALF	RNE	THALF	TNF	TMEND
---	-----	-----	-------	-----	-------	-----	-------

SYMBOL	POSITION	NAME AND DESCRIPTION
—	HSR.7	Not Assigned. Should be set to zero.
RPE	HSR.6	Receive Packet End. Set when the HDLC controller detects either the finish of a valid message (i.e., CRC check complete) or when the controller has experienced a message fault such as a CRC checking error, or an overrun condition, or an abort has been seen. The setting of this bit prompts the user to read the RHIR register for details.
RPS	HSR.5	Receive Packet Start. Set when the HDLC controller detects an opening byte. The setting of this bit prompts the user to read the RHIR register for details.
RHALF	HSR.4	Receive FIFO Half Full. Set when the receive 64 byte FIFO fills beyond the half-way point. The setting of this bit prompts the user to read the RHIR register for details.
RNE	HSR.3	Receive FIFO Not Empty. Set when the receive 64 byte FIFO has at least 1 byte available for a read. The setting of this bit prompts the user to read the RHIR register for details.
THALF	HSR.2	Transmit FIFO Half Empty. Set when the transmit 64 byte FIFO empties beyond the half-way point. The setting of this bit prompts the user to read the THIR register for details.
TNF	HSR.1	Transmit FIFO Not Full. Set when the transmit 64 byte FIFO has at least 1 byte available. The setting of this bit prompts the user to read the THIR register for details.
TMEND	HSR.0	Transmit Message End. Set when the transmit HDLC controller has finished sending a message. The setting of this bit prompts the user to read the THIR register for details.

Note: The RPE, RPS, and TMEND bits are latched and are cleared when read.

HIMR: HDLC INTERRUPT MASK REGISTER (Address = B2 Hex)**(MSB)****(LSB)**

—	RPE	RPS	RHALF	RNE	THALF	TNF	TMEND
---	-----	-----	-------	-----	-------	-----	-------

SYMBOL	POSITION	NAME AND DESCRIPTION
—	HIMR.7	Not Assigned. Should be set to zero.
RPE	HIMR.6	Receive Packet End 0 = interrupt masked 1 = interrupt enabled
RPS	HIMR.5	Receive Packet Start 0 = interrupt masked 1 = interrupt enabled
RHALF	HIMR.4	Receive FIFO Half Full 0 = interrupt masked 1 = interrupt enabled
RNE	HIMR.3	Receive FIFO Not Empty 0 = interrupt masked 1 = interrupt enabled
THALF	HIMR.2	Transmit FIFO Half Empty 0 = interrupt masked 1 = interrupt enabled
TNF	HIMR.1	Transmit FIFO Not Full 0 = interrupt masked 1 = interrupt enabled
TMEND	HIMR.0	Transmit Message End 0 = interrupt masked 1 = interrupt enabled

RHIR: RECEIVE HDLC INFORMATION REGISTER (Address = B3 Hex)**(MSB)****(LSB)**

RABT	RRCCE	ROVR	RVM	REMPY	POK	CBYTE	OBYTE
------	-------	------	-----	-------	-----	-------	-------

SYMBOL	POSITION	NAME AND DESCRIPTION
RABT	RHIR.7	Abort Sequence Detected. Set whenever the HDLC controller sees seven or more ones in a row.
RRCCE	RHIR.6	CRC Error. Set when the CRC checksum is in error.
ROVR	RHIR.5	Overrun. Set when the HDLC controller has attempted to write a byte into an already full receive FIFO.
RVM	RHIR.4	Valid Message. Set when the HDLC controller has detected and checked a complete HDLC packet.
REMPY	RHIR.3	Empty. A real-time bit that is set high when the receive FIFO is empty.
POK	RHIR.2	Packet OK. Set when the byte available for reading in the receive FIFO at RHFR is the last byte of a valid message (and hence no abort was seen, no overrun occurred, and the CRC was correct).
CBYTE	RHIR.1	Closing Byte. Set when the byte available for reading in the receive FIFO at RFDL is the last byte of a message (whether the message was valid or not).
OBYTE	RHIR.0	Opening Byte. Set when the byte available for reading in the receive FIFO at RHFR is the first byte of a message.

Note: The RABT, RRCCE, ROVR, and RVM bits are latched and are cleared when read.

RHFR: RECEIVE HDLC FIFO REGISTER (Address = B4 Hex)**(MSB)****(LSB)**

HDLC7	HDLC6	HDLC5	HDLC4	HDLC3	HDLC2	HDLC1	HDLC0
-------	-------	-------	-------	-------	-------	-------	-------

SYMBOL	POSITION	NAME AND DESCRIPTION
HDLC7	RHFR.7	HDLC Data Bit 7. MSB of a HDLC packet data byte.
HDLC6	RHFR.6	HDLC Data Bit 6
HDLC5	RHFR.5	HDLC Data Bit 5
HDLC4	RHFR.4	HDLC Data Bit 4
HDLC3	RHFR.3	HDLC Data Bit 3
HDLC2	RHFR.2	HDLC Data Bit 2
HDLC1	RHFR.1	HDLC Data Bit 1
HDLC0	RHFR.0	HDLC Data Bit 0. LSB of a HDLC packet data byte.

THIR: TRANSMIT HDLC INFORMATION REGISTER (Address = B6 Hex)**(MSB)****(LSB)**

—	—	—	—	—	EMPTY	TFULL	TUDR
---	---	---	---	---	-------	-------	------

SYMBOL	POSITION	NAME AND DESCRIPTION
—	THIR.7	Not Assigned. Could be any value when read.
—	THIR.6	Not Assigned. Could be any value when read.
—	THIR.5	Not Assigned. Could be any value when read.
—	THIR.4	Not Assigned. Could be any value when read.
—	THIR.3	Not Assigned. Could be any value when read.
EMPTY	THIR.2	Transmit FIFO Empty. A real-time bit that is set high when the FIFO is empty.
TFULL	THIR.1	Transmit FIFO Full. A real-time bit that is set high when the FIFO is full.
TUDR	THIR.0	Transmit FIFO Underrun. Set when the transmit FIFO unwantedly empties out and an abort is automatically sent.

Note: The TUDR bit is latched and are cleared when read.

THFR: TRANSMIT HDLC FIFO REGISTER (Address = B7 Hex)**(MSB)****(LSB)**

HDLC7	HDLC6	HDLC5	HDLC4	HDLC3	HDLC2	HDLC1	HDLC0
-------	-------	-------	-------	-------	-------	-------	-------

SYMBOL	POSITION	NAME AND DESCRIPTION
HDLC7	THFR.7	HDLC Data Bit 7. MSB of a HDLC packet data byte.
HDLC6	THFR.6	HDLC Data Bit 6
HDLC5	THFR.5	HDLC Data Bit 5
HDLC4	THFR.4	HDLC Data Bit 4
HDLC3	THFR.3	HDLC Data Bit 3
HDLC2	THFR.2	HDLC Data Bit 2
HDLC1	THFR.1	HDLC Data Bit 1
HDLC0	THFR.0	HDLC Data Bit 0. LSB of a HDLC packet data byte.

RDC1: RECEIVE HDLC DS0 CONTROL REGISTER 1 (Address = B8 Hex)**(MSB)****(LSB)**

RHS	RSaDS	RDS0M	RD4	RD3	RD2	RD1	RD0
-----	-------	-------	-----	-----	-----	-----	-----

SYMBOL	POSITION	NAME AND DESCRIPTION
RHS	RDC1.7	Receive HDLC Source 0 = Sa bits defined by RCR2.3 to RCR2.7 1 = Sa bits or DS0 channels defined by RDC1 (see bits defined below)
RSaDS	RDC1.6	Receive Sa Bit/DS0 Select 0 = route Sa bits to the HDLC controller. RD0 to RD4 defines which Sa bits are to be routed. RD4 corresponds to Sa4, RD3 to Sa5, RD2 to Sa6, RD1 to Sa7, and RD0 to Sa8. 1 = route DS0 channels into the HDLC controller. RDC1.5 is used to determine how the DS0 channels are selected.
RDS0M	RDC1.5	DS0 Selection Mode 0 = utilize the RD0 to RD4 bits to select which single DS0 channel to use. 1 = utilize the RCHBLK control registers to select which DS0 channels to use.
RD4	RDC1.4	DS0 Channel Select Bit 4. MSB of the DS0 channel select.
RD3	RDC1.3	DS0 Channel Select Bit 3
RD2	RDC1.2	DS0 Channel Select Bit 2
RD1	RDC1.1	DS0 Channel Select Bit 1
RD0	RDC1.0	DS0 Channel Select Bit 0. LSB of the DS0 channel select.

RDC2: RECEIVE HDLC DS0 CONTROL REGISTER 2 (Address = B9 Hex)**(MSB)****(LSB)**

RDB8	RDB7	RDB6	RDB5	RDB4	RDB3	RDB2	RDB1
------	------	------	------	------	------	------	------

SYMBOL	POSITION	NAME AND DESCRIPTION
RDB8	RDC2.7	DS0 Bit 8 Suppress Enable. MSB of the DS0. Set to one to stop this bit from being used.
RDB7	RDC2.6	DS0 Bit 7 Suppress Enable. Set to one to stop this bit from being used.
RDB6	RDC2.5	DS0 Bit 6 Suppress Enable. Set to one to stop this bit from being used.
RDB5	RDC2.4	DS0 Bit 5 Suppress Enable. Set to one to stop this bit from being used.
RDB4	RDC2.3	DS0 Bit 4 Suppress Enable. Set to one to stop this bit from being used.
RDB3	RDC2.2	DS0 Bit 3 Suppress Enable. Set to one to stop this bit from being used.
RDB2	RDC2.1	DS0 Bit 2 Suppress Enable. Set to one to stop this bit from being used.
RDB1	RDC2.0	DS0 Bit 1 Suppress Enable. LSB of the DS0. Set to one to stop this bit from being used.

TDC1: TRANSMIT HDLC DS0 CONTROL REGISTER 1 (Address = BA Hex)**(MSB)****(LSB)**

THE	TSaDS	TDS0M	TD4	TD3	TD2	TD1	TD0
-----	-------	-------	-----	-----	-----	-----	-----

SYMBOL	POSITION	NAME AND DESCRIPTION
THE	TDC1.7	Transmit HDLC Enable 0 = disable HDLC controller (no data inserted by HDLC controller into the transmit data stream) 1 = enable HDLC controller to allow insertion of HDLC data into either the Sa position or multiple DS0 channels as defined by TDC1 (see bit definitions below)
TSaDS	TDC1.6	Transmit Sa Bit/DS0 Select. This bit is ignored if TDC1.7 is set to zero. 0 = route Sa bits from the HDLC controller. TD0 to TD4 defines which Sa bits are to be routed. TD4 corresponds to Sa4, TD3 to Sa5, TD2 to Sa6, TD1 to Sa7, and TD0 to Sa8. 1 = route DS0 channels from the HDLC controller. TDC1.5 is used to determine how the DS0 channels are selected.
TDS0M	TDC1.5	DS0 Selection Mode 0 = use the TD0 to TD4 bits to select which single DS0 channel to use 1 = use the TCHBLK control registers to select which DS0 channels to use
TD4	TDC1.4	DS0 Channel Select Bit 4. MSB of the DS0 channel select.
TD3	TDC1.3	DS0 Channel Select Bit 3
TD2	TDC1.2	DS0 Channel Select Bit 2
TD1	TDC1.1	DS0 Channel Select Bit 1
TD0	TDC1.0	DS0 Channel Select Bit 0. LSB of the DS0 channel select.

TDC2: TRANSMIT HDLC DS0 CONTROL REGISTER 2 (Address = BB Hex)**(MSB)****(LSB)**

TDB8	TDB7	TDB6	TDB5	TDB4	TDB3	TDB2	TDB1
------	------	------	------	------	------	------	------

SYMBOL	POSITION	NAME AND DESCRIPTION
TDB8	TDC2.7	DS0 Bit 8 Suppress Enable. MSB of the DS0. Set to one to stop this bit from being used.
TDB7	TDC2.6	DS0 Bit 7 Suppress Enable. Set to one to stop this bit from being used.
TDB6	TDC2.5	DS0 Bit 6 Suppress Enable. Set to one to stop this bit from being used.
TDB5	TDC2.4	DS0 Bit 5 Suppress Enable. Set to one to stop this bit from being used.
TDB4	TDC2.3	DS0 Bit 4 Suppress Enable. Set to one to stop this bit from being used.
TDB3	TDC2.2	DS0 Bit 3 Suppress Enable. Set to one to stop this bit from being used.
TDB2	TDC2.1	DS0 Bit 2 Suppress Enable. Set to one to stop this bit from being used.
TDB1	TDC2.0	DS0 Bit 1 Suppress Enable. LSB of the DS0. Set to one to stop this bit from being used.

20. INTERLEAVED PCM BUS OPERATION

In many architectures, the outputs of individual framers are combined into higher speed serial buses to simplify transport across the system. The DS21Q44 can be configured to allow each framer's data and signaling busses to be multiplexed into higher speed data and signaling busses eliminating external hardware saving board space and cost.

The interleaved PCM bus option supports two bus speeds and interleave modes. The 4.096MHz bus speed allows two framers to share a common bus. The 8.192MHz bus speed allows all four of the DS21Q44's framers to share a common bus. Framers can interleave their data either on byte or frame boundaries. Framers that share a common bus must be configured through software and require several device pins to be connected together externally (Figures 20-1 and 20-2). Each framer's elastic stores must be enabled and configured for 2.048MHz operation. The signal RSYNC must be configured as an input on each framer.

For all bus configurations, one framer will be configured as the master device and the remaining framers on the shared bus will be configured as slave devices. Refer to the IBO register description below for more detail. In the 4.096MHz bus configuration there is one master and one slave per bus. Figure 20-1 shows the DS21Q44 configured to support two 4.096 MHz buses. Bus 1 consists of framers 0 and 1. Bus 2 consists of framers 2 and 3. Framers 0 and 2 are programmed as master devices. Framers 1 and 3 are programmed as slave devices. In the 8.192 MHz bus configuration there is one master and three slaves. Figure 20-2 shows the DS21Q44 configured to support an 8.192MHz bus. Framer 0 is programmed as the master device. Framers 1, 2, and 3 are programmed as slave devices. Consult timing diagrams in section 22 for additional information.

When using the frame interleave mode, all framers that share an interleaved bus must have receive signals (RPOS and RNEG) that are synchronous with each other. The received signals must originate from the same clock reference. This restriction does not apply in the byte interleave mode.

IBO: INTERLEAVE BUS OPERATION REGISTER (Address = B5 Hex)

(MSB)				(LSB)			
—	—	—	—	IBOEN	INTSEL	MSEL0	MSEL1
SYMBOL	POSITION	NAME AND DESCRIPTION					
—	IBO.7	Not Assigned. Should be set to 0.					
—	IBO.6	Not Assigned. Should be set to 0.					
—	IBO.5	Not Assigned. Should be set to 0.					
—	IBO.4	Not Assigned. Should be set to 0.					
IBOEN	IBO.3	Interleave Bus Operation Enable 0 = Interleave Bus Operation disabled 1 = Interleave Bus Operation enabled					
INTSEL	IBO.2	Interleave Type Select 0 = Byte interleave 1 = Frame interleave					
MSEL0	IBO.1	Master Device Bus Select Bit 0 (Table 20-1)					
MSEL1	IBO.0	Master Device Bus Select Bit 1 (Table 20-1)					

Table 20-1. MASTER DEVICE BUS SELECT

MSEL1	MSEL0	FUNCTION
0	0	Slave device
0	1	Master device with one slave device (4.096MHz bus rate)
1	0	Master device with three slave devices (8.192MHz bus rate)
1	1	Reserved

Figure 20-1. 4.096MHz INTERLEAVED BUS EXTERNAL PIN CONNECTION EXAMPLE

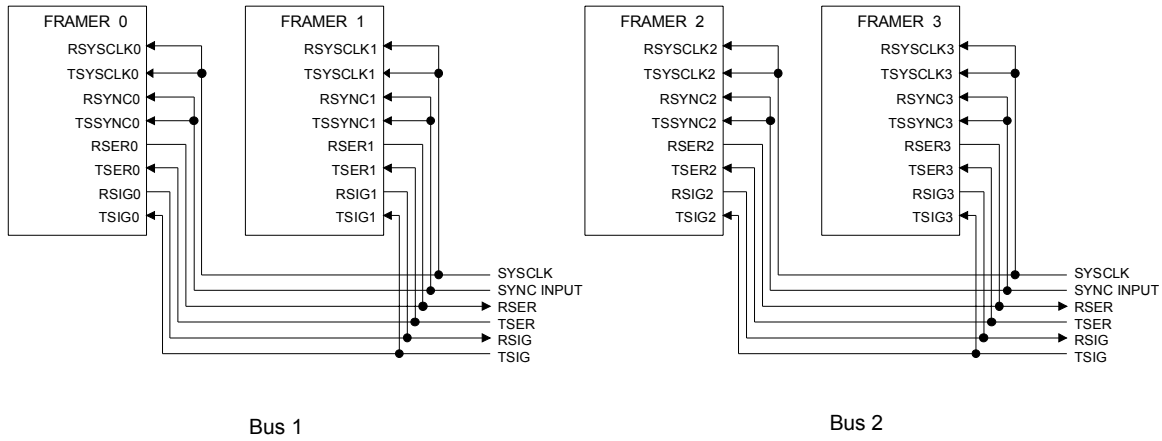
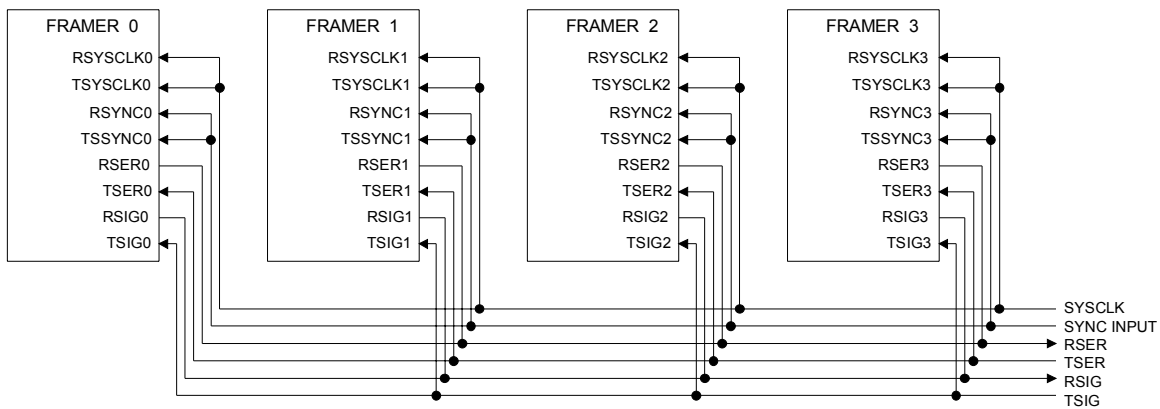

Figure 20-2. 8.192MHz INTERLEAVED BUS EXTERNAL PIN CONNECTION EXAMPLE



21. JTAG-BOUNDARY SCAN ARCHITECTURE AND TEST ACCESS PORT

21.1. DESCRIPTION

The DS21Q44 IEEE 1149.1 design supports the standard instruction codes SAMPLE/PRELOAD, BYPASS, and EXTEST. Optional public instructions included with this design are HIGHZ, CLAMP, and IDCODE. See Figure 21-1 for a block diagram. The DS21Q44 contains the following items which meet the requirements set by the IEEE 1149.1 Standard Test Access Port and Boundary Scan Architecture. *The DS21FT42 should be considered as 3 individual DS21Q42 devices. The DS21FF44 should be considered as 4 individual DS21Q44 devices.*

Test Access Port (TAP)

TAP Controller

Instruction Register

Bypass Register

Boundary Scan Register

Device Identification Register

The JTAG feature is only available when the DS21Q44 feature set is selected (FMS = 0). The JTAG feature is disabled when the DS21Q44 is configured for emulation of the DS21Q43 (FMS = 1). *FMS is connected to ground for the DS21FF44/DS21FT44.*

Details on Boundary Scan Architecture and the Test Access Port can be found in IEEE 1149.1-1990, IEEE 1149.1a-1993, and IEEE 1149.1b-1994.

The Test Access Port has the necessary interface pins; JTRST*, JTCLK, JTMS, JTDI, and JTDO. See the pin descriptions for details.

Figure 21-1. BOUNDARY SCAN ARCHITECTURE

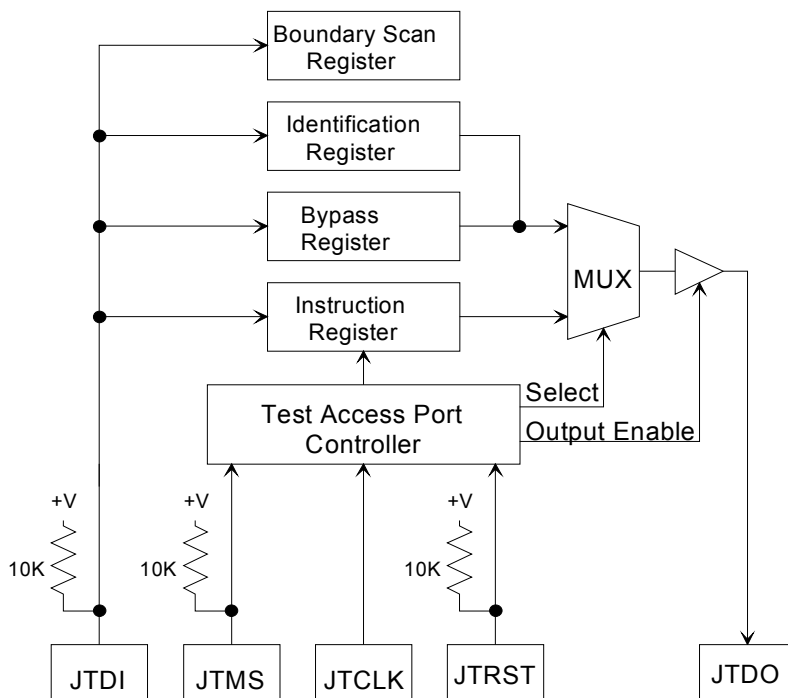

21.2. TAP CONTROLLER STATE MACHINE

This section covers the details on the operation of the Test Access Port (TAP) Controller State Machine. Please see Figure 21.2 for details on each of the states described below.

TAP Controller

The TAP controller is a finite state machine that responds to the logic level at JTMS on the rising edge of JTCLK.

Test-Logic-Reset

Upon power-up of the DS21Q44, the TAP Controller will be in the Test-Logic-Reset state. The Instruction register will contain the IDCODE instruction. All system logic of the DS21Q44 will operate normally.

Run-Test-Idle

The Run-Test-Idle is used between scan operations or during specific tests. The Instruction register and Test registers will remain idle.

Select-DR-Scan

All test registers retain their previous state. With JTMS low, a rising edge of JTCLK moves the controller into the Capture-DR state and will initiate a scan sequence. JTMS HIGH during a rising edge on JTCLK moves the controller to the Select-IR

Capture-DR

Data may be parallel-loaded into the Test Data registers selected by the current instruction. If the instruction does not call for a parallel load or the selected register does not allow parallel loads, the Test register will remain at its current value. On the rising edge of JTCLK, the controller will go to the Shift-DR state if JTMS is low or it will go to the Exit1-DR state if JTMS is high.

Shift-DR

The Test Data register selected by the current instruction will be connected between JTDI and JTDO and will shift data one stage towards its serial output on each rising edge of JTCLK. If a Test Register selected by the current instruction is not placed in the serial path, it will maintain its previous state.

Exit1-DR

While in this state, a rising edge on JTCLK with JTMS high will put the controller in the Update-DR state, and terminate the scanning process. A rising edge on JTCLK with JTMS low will put the controller in the Pause-DR state.

Pause-DR

Shifting of the test registers is halted while in this state. All Test registers selected by the current instruction will retain their previous state. The controller will remain in this state while JTMS is low. A rising edge on JTCLK with JTMS high will put the controller in the Exit2-DR state.

Exit2-DR

While in this state, a rising edge on JTCLK with JTMS high will put the controller in the Update-DR state and terminate the scanning process. A rising edge on JTCLK with JTMS low will enter the Shift-DR state.

Update-DR

A falling edge on JTCLK while in the Update-DR state will latch the data from the shift register path of the Test registers into the data output latches. This prevents changes at the parallel output due to changes in the shift register. A rising edge on JTCLK with JTMS low, will put the controller in the Run-Test-Idle state. With JTMS high, the controller will enter the Select-DR-Scan state.

Select-IR-Scan

All test registers retain their previous state. The instruction register will remain unchanged during this state. With JTMS low, a rising edge of JTCLK moves the controller into the Capture-IR state and will initiate a scan sequence for the Instruction register. JTMS high during a rising edge on JTCLK puts the controller back into the Test-Logic-Reset state.

Capture-IR

The Capture-IR state is used to load the shift register in the instruction register with a fixed value. This value is loaded on the rising edge of JTCLK. If JTMS is high on the rising edge of JTCLK, the controller will enter the Exit1-IR state. If JTMS is low on the rising edge of JTCLK, the controller will enter the Shift-IR state.

Shift-IR

In this state, the shift register in the instruction register is connected between JTDI and JTDO and shifts data one stage for every rising edge of JTCLK towards the serial output. The parallel registers, as well as all Test registers remain at their previous states. A rising edge on JTCLK with JTMS high will move the controller to the Exit1-IR state. A rising edge on JTCLK with JTMS low will keep the controller in the Shift-IR state while moving data one stage through the instruction shift register.

Exit1-IR

A rising edge on JTCLK with JTMS low will put the controller in the Pause-IR state. If JTMS is high on the rising edge of JTCLK, the controller will enter the Update-IR state and terminate the scanning process.

Pause-IR

Shifting of the instruction shift register is halted temporarily. With JTMS high, a rising edge on JTCLK will put the controller in the Exit2-IR state. The controller will remain in the Pause-IR state if JTMS is low during a rising edge on JTCLK.

Exit2-IR

A rising edge on JTCLK with JTMS low will put the controller in the Update-IR state. The controller will loop back to Shift-IR if JTMS is high during a rising edge of JTCLK in this state.

Update-IR

The instruction code shifted into the instruction shift register is latched into the parallel output on the falling edge of JTCLK as the controller enters this state. Once latched, this instruction becomes the current instruction. A rising edge on JTCLK with JTMS low, will put the controller in the Run-Test-Idle state. With JTMS high, the controller will enter the Select-DR-Scan state.

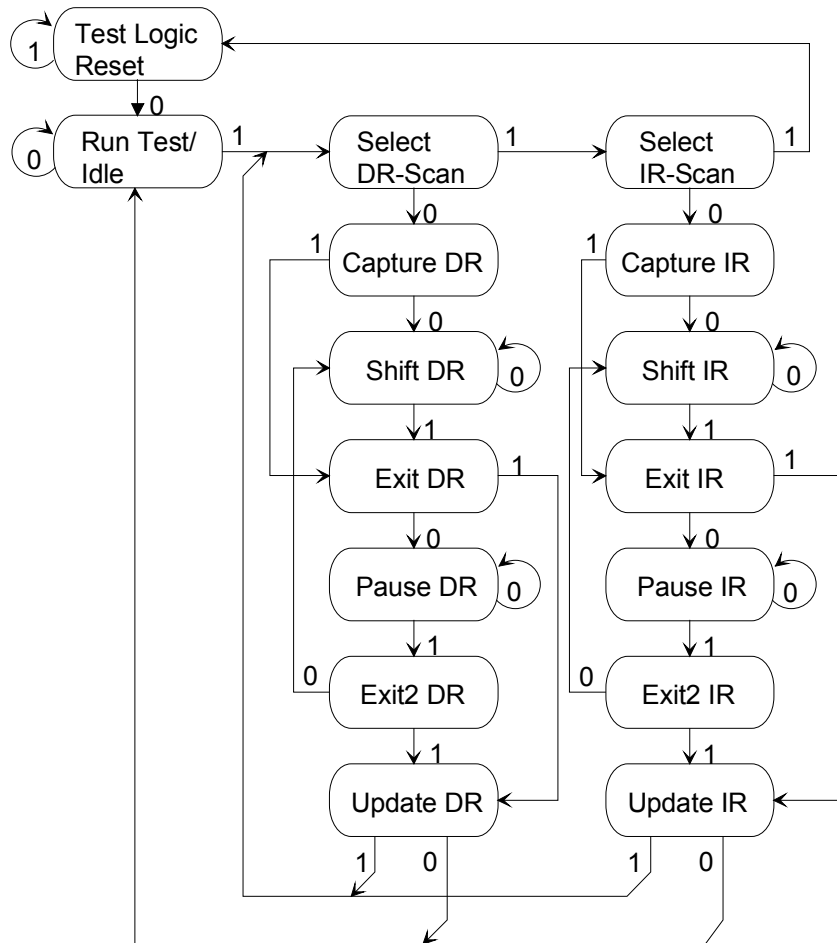
Figure 21-2. TAP CONTROLLER STATE MACHINE

21.3. INSTRUCTION REGISTER AND INSTRUCTIONS

The instruction register contains a shift register as well as a latched parallel output and is 3 bits in length. When the TAP controller enters the Shift-IR state, the instruction shift register will be connected between JTDI and JTDO. While in the Shift-IR state, a rising edge on JTCLK with JTMS low will shift the data one stage towards the serial output at JTDO. A rising edge on JTCLK in the Exit1-IR state or the Exit2-IR state with JTMS high will move the controller to the Update-IR state. The falling edge of that same JTCLK will latch the data in the instruction shift register to the instruction parallel output. Instructions supported by the DS21Q44 with their respective operational binary codes are shown in Table 21-1.

Table 21-1. INSTRUCTION CODES FOR THE DS21Q44 IEEE 1149.1 ARCHITECTURE

INSTRUCTION	SELECTED REGISTER	INSTRUCTION CODE
SAMPLE/PRELOAD	Boundary Scan	010
BYPASS	Bypass	111
EXTEST	Boundary Scan	000
CLAMP	Boundary Scan	011
HIGHZ	Boundary Scan	100
IDCODE	Device Identification	001

SAMPLE/PRELOAD

A mandatory instruction for the IEEE 1149.1 specification. This instruction supports two functions. The digital I/Os of the DS21Q44 can be sampled at the boundary scan register without interfering with the normal operation of the device by using the Capture-DR state. SAMPLE/PRELOAD also allows the DS21Q44 to shift data into the boundary scan register by JTDI using the Shift-DR state.

EXTEST

EXTEST allows testing of all interconnections to the DS21Q44. When the EXTEST instruction is latched in the instruction register, the following actions occur. Once enabled by the Update-IR state, the parallel outputs of all digital output pins will be driven. The boundary scan register will be connected between JTDI and JTDO. The Capture-DR will sample all digital inputs into the boundary scan register.

BYPASS

When the BYPASS instruction is latched into the parallel instruction register, JTDI connects to JTDO through the 1 bit bypass test register. This allows data to pass from JTDI to JTDO not affecting the device's normal operation.

IDCODE

When the IDCODE instruction is latched into the parallel instruction register, the Identification Test register is selected. The device identification code will be loaded into the Identification register on the rising edge of JTCLK following entry into the Capture-DR state. Shift-DR can be used to shift the identification code out serially by JTDO. During Test-Logic-Reset, the identification code is forced into the instruction register's parallel output. The ID code will always have a '1' in the LSB position. The next 11 bits identify the manufacturer's JEDEC number and number of continuation bytes followed by 16 bits for the device and 4 bits for the version. See Table 21-2. Table 21-3 lists the device ID codes for the DS21Q42 and DS21Q44 devices.

Table 21-2. ID CODE STRUCTURE

	MSB			LSB
CONTENTS	Version (Contact Factory)	Device ID (See Table 21-3)	JEDEC "00010100001"	"1"
LENGTH	4 bits	16 bits	11 bits	1 bit

Table 21-3. DEVICE ID CODES

DEVICE	16-BIT NUMBER
DS21Q42	0000h
DS21Q44	0001h

HIGH-Z

All digital outputs of the DS21Q44 will be placed in a high impedance state. The BYPASS register will be connected between JTDI and JTDO.

CLAMP

All digital outputs of the DS21Q44 will output data from the boundary scan parallel output while connecting the bypass register between JTDI and JTDO. The outputs will not change during the CLAMP instruction.

21.4. TEST REGISTERS

IEEE 1149.1 requires a minimum of two test registers; the bypass register and the boundary scan register. An optional test register has been included with the DS21Q44 design. This test register is the identification register and is used in conjunction with the IDCODE instruction and the Test-Logic-Reset state of the TAP controller.

Boundary Scan Register

This register contains both a shift register path and a latched parallel output for all control cells and digital I/O cells and is 126 bits in length. Table 21-3 shows all of the cell bit locations and definitions.

Bypass Register

This is a single 1-bit shift register used in conjunction with the BYPASS, CLAMP, and HIGH-Z instructions, which provides a short path between JTDI and JTDO.

Identification Register

The identification register contains a 32-bit shift register and a 32 bit latched parallel output. This register is selected during the IDCODE instruction and when the TAP controller is in the Test-Logic-Reset state.

Table 21-4. BOUNDARY SCAN REGISTER DESCRIPTION

MCM PIN (DIE1)	MCM PIN (DIE2)	MCM PIN (DIE3)	MCM PIN (DIE4)	SCAN REGISTER BIT	DS21Q42 DIE SYMBOL	TYPE	CONTROL BIT DESCRIPTION
B7				102	8MCLK	O	
G20	G20	G20	G20	60	A0	I	
H20	H20	H20	H20	59	A1	I	
G19	G19	G19	G19	58	A2	I	
H19	H19	H19	H19	57	A3	I	
G18	G18	G18	G18	56	A4	I	
H18	H18	H18	H18	55	A5	I	
G17	G17	G17	G17	54	A6/ALE (AS)	I	
H17	H17	H17	H17	37	A7	I	
W15	W15	W15	W15	22	BTS	I	
—				94	BUS.cntl	—	0 = D0–D7 or AD0–AD7 are inputs 1 = D0–D7 or AD0–AD7 are outputs
B6				100	CLKSI	I	
T8	Y4	Y15	E19	23	CS*	I	
L20	L20	L20	L20	93	D0 or AD0	I/O	
M20	M20	M20	M20	92	D1 or AD1	I/O	
L19	L19	L19	L19	91	D2 or AD2	I/O	
M19	M19	M19	M19	90	D3 or AD3	I/O	
L18	L18	L18	L18	89	D4 or AD4	I/O	
M18	M18	M18	M18	88	D5 or AD5	I/O	
L17	L17	L17	L17	87	D6 or AD6	I/O	
M17	M17	M17	M17	86	D7 or AD7	I/O	
Y14	Y14	Y14	Y14	25	FS0	I	
W14	W14	W14	W14	24	FS1	I	
G16	G16	G16	G16	53	INT*	O	
V14	V14	V14	V14	—	JTCLK	I	
E10	E10	E10	E10	—	JTDI	I	
			A19	—	JTDOF	O	
		T17		—	JTDOT	O	
H16	H16	H16	H16	—	JTMS	I	
K17	K17	K17	K17	—	JTRST*	I	
P17	P17	P17	P17	19	MUX	I	
C2	N1	Y8	D16	72	RCHBLK0	O	
G3	Y1	W12	K20	39	RCHBLK1	O	
E6	U6	V17	B18	5	RCHBLK2	O	
A8	N5	U17	B16	107	RCHBLK3	O	
A2	M3	T9	D14	76	RCLK0	I	
K1	V1	W10	P20	43	RCLK1	I	
D10	W6	Y18	C18	9	RCLK2	I	
B9	J3	N17	C12	111	RCLK3	I	
E18	E18	E18	E18	21	RD*/(DS*)	I	
B2	M2	U9	E14	75	RNEG0	I	
H2	V3	W11	N20	42	RNEG1	I	
D9	V7	W17	C20	8	RNEG2	I	
A9	P3	T20	B13	110	RNEG3	I	

MCM PIN (DIE1)	MCM PIN (DIE2)	MCM PIN (DIE3)	MCM PIN (DIE4)	SCAN REGISTER BIT	DS21Q42 DIE SYMBOL	TYPE	CONTROL BIT DESCRIPTION
A1	M1	T10	D15	74	RPOS0	I	
H1	W2	V11	J18	41	RPOS1	I	
H4	V5	Y19	A20	7	RPOS2	I	
C9	P4	R19	A14	109	RPOS3	I	
C1	P1	U11	E16	68	RSER0	O	
H3	W4	Y12	F20	33	RSER1	O	
C6	T7	V16	C16	1	RSER2	O	
C8	N4	T16	A12	103	RSER3	O	
D3	N2	U10	E15	73	RSIG0	O	
G2	V4	Y11	K19	40	RSIG1	O	
D4	V6	W19	C17	6	RSIG2	O	
D8	K5	U20	A15	108	RSIG3	O	
B1	N3	T11	J17	69	RSYNC0	I/O	
—				70	RSYNC0.cntl	—	0 = RSYNC0 an input 1 = RSYNC0 an output
G1	Y2	V13	J19	34	RSYNC1	I/O	
—				35	RSYNC1.cntl	—	0 = RSYNC1 an input 1 = RSYNC1 an output
D6	U5	V15	B17	2	RSYNC2	I/O	
—				3	RSYNC2.cntl	—	0 = RSYNC2 an input 1 = RSYNC2 an output
A7	J4	P18	B12	104	RSYNC3	I/O	
—				105	RSYNC3.cntl	—	0 = RSYNC3 an input 1 = RSYNC3 an output
B5	M4	T4	E13	71	*RSYSCLK0	I	
E2	T2	Y9	N18	38	*RSYSCLK1	I	
E5	Y5	U12	E20	4	*RSYSCLK2	I	
B8	W3	R17	C14	106	*RSYSCLK3	I	
D1	R1	U13	K16	65	TCLK0	I	
H5	Y3	Y13	F19	31	TCLK1	I	
C5	T6	T18	E17	125	TCLK2	I	
A5	K2	P16	C11	99	TCLK3	I	
A13	A13	A13	A13	26	TEST	I	
C3	L1	U14	D11	79	TNEG0	O	
J1	V2	V12	K18	46	TNEG1	O	
F5	V8	W18	C19	12	TNEG2	O	
A10	P5	T19	B15	114	TNEG3	O	
B3	L2	T14	E12	80	TPOS0	O	
J2	W1	Y10	N19	47	TPOS1	O	
J5	W7	V18	B19	13	TPOS2	O	
B10	R3	V20	B14	115	TPOS3	O	

MCM PIN (DIE1)	MCM PIN (DIE2)	MCM PIN (DIE3)	MCM PIN (DIE4)	SCAN REGISTER BIT	DS21Q42 DIE SYMBOL	TYPE	CONTROL BIT DESCRIPTION
B4	L5	M16	D13	84	TSER0	I	
E1	T1	W9	F17	51	TSER1	I	
F3	Y6	W16	D18	17	TSER2	I	
D7	T3	W20	A18	119	TSER3	I	
C4	L3	U15	E11	82	TSIG0	I	
F1	U2	V10	P19	49	TSIG1	I	
G4	V9	U18	B20	15	TSIG2	I	
C10	R5	R18	A16	117	TSIG3	I	
A3	L4	T15	C13	83	TSSYNC0	I	
F2	U1	W8	R20	50	TSSYNC1	I	
G5	Y7	Y17	D20	16	TSSYNC2	I	
E8	R4	U19	A17	118	TSSYNC3	I	
E3	R2	T13	J16	62	TSYNC0	I/O	
—				63	TSYNC0.cntl	—	0 = TSYNC0 an input 1 = TSYNC0 an output
F4	W5	W13	F18	28	TSYNC1	I/O	
—				29	TSYNC1.cntl	—	0 = TSYNC1 an input 1 = TSYNC1 an output
E7	T5	U16	C15	122	TSYNC2	I/O	
—				123	TSYNC2.cntl	—	0 = TSYNC2 an input 1 = TSYNC2 an output
A4	M5	N16	D12	96	TSYNC3	I/O	
—				97	TSYNC3.cntl	—	0 = TSYNC3 an input 1 = TSYNC3 an output
B5	M4	T4	E13	85	*TSYSCLK0	I	
E2	T2	Y9	N18	52	*TSYSCLK1	I	
E5	Y5	U12	E20	18	*TSYSCLK2	I	
B8	W3	R17	C14	120	*TSYSCLK3	I	
C7	K3	V19	D17	—	VDD	—	
E4	U7	T12	F16	—	VDD	—	
D2	P2	L16	B11	—	VDD	—	
E9	U3	U4	J20	—	VSS	—	
A6	K4	R16	A11	—	VSS	—	
D5	U8	Y20	D19	—	VSS	—	
Y16	Y16	Y16	Y16	20	WR*/(R/W*)	I	

*RSYSCLKn and TSYCLKn are connected together.

22. TIMING DIAGRAMS

Figure 22-1. RECEIVE SIDE TIMING

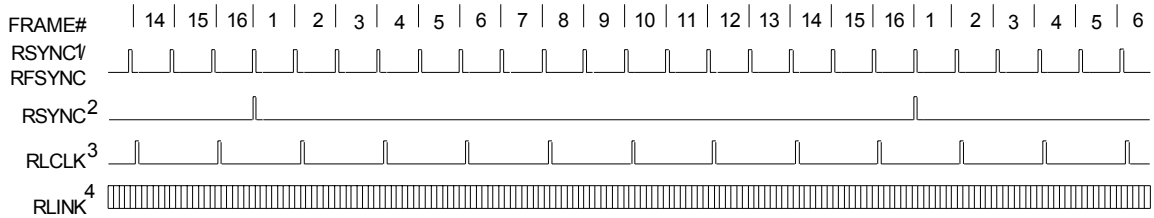

Notes:

1. RSYNC in the frame mode (RCR1.6 = 0)
2. RSYNC in the multiframe mode (RCR1.6 = 1)
3. RLCLK is programmed to output just the Sa4 bit
4. RLINK will always output all five Sa bits as well as the rest of the receive data stream
5. This diagram assumes the CAS MF begins with the FAS word

Figure 22-2. RECEIVE SIDE BOUNDARY TIMING (With Elastic Store Disabled)

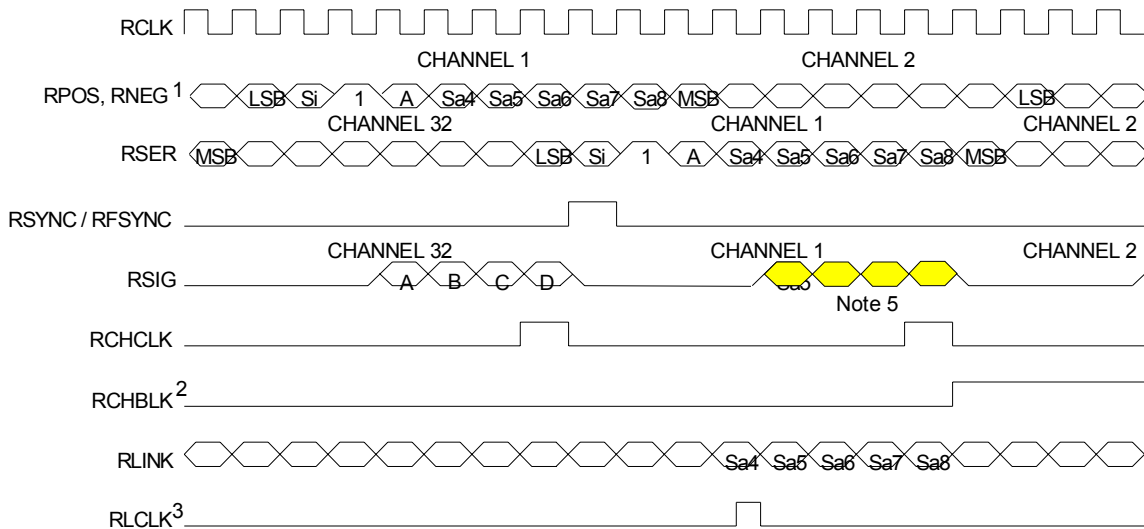

Notes:

1. There is a 6 RCLK delay from RPOS, RNEG to RSER
2. RCHBLK is programmed to block channel 2
3. RLINK is programmed to output the Sa4 bit
4. Shown is a non-align frame boundary
5. RSIG normally contains the CAS multiframe alignment nibble (0000) in Channel 1

Figure 22-3. RECEIVE SIDE 1.544MHz BOUNDARY TIMING (With Elastic Store Enabled)

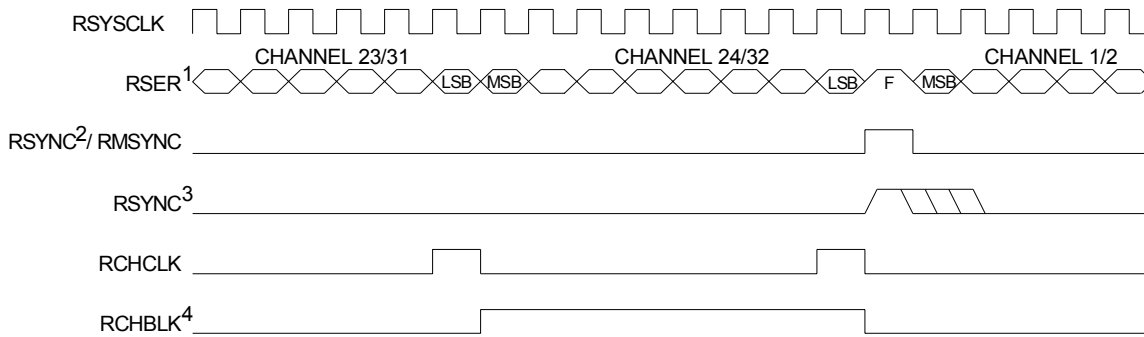

Notes:

1. Data from the E1 channels 1, 5, 9, 13, 17, 21, 25, and 29 is dropped (channel 2 from the E1 link is mapped to channel 1 of the T1 link, etc.) and the F-bit position is added (forced to one)
2. RSYNC is in the output mode (RCR1.5 = 0)
3. RSYNC is in the input mode (RCR1.5 = 1)
4. RCHBLK is programmed to block channel 24

Figure 22-4. RECEIVE SIDE 2.048MHz BOUNDARY TIMING (With Elastic Store Enabled)

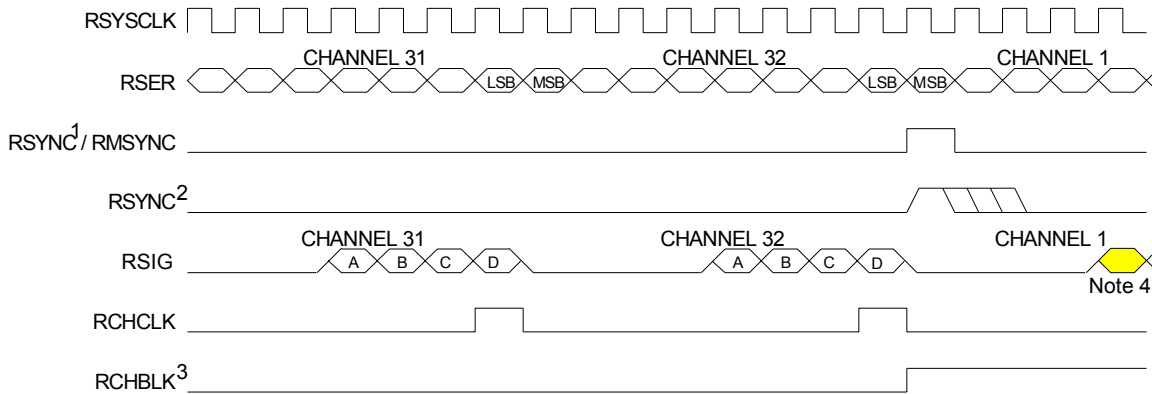

Notes:

1. RSYNC is in the output mode (RCR1.5 = 0)
2. RSYNC is in the input mode (RCR1.5 = 1)
3. RCHBLK is programmed to block channel 1
4. RSIG normally contains the CAS multiframe alignment nibble (0000) in Channel 1

Figure 22-5. RECEIVE SIDE, INTERLEAVED BUS OPERATION BYTE MODE TIMING

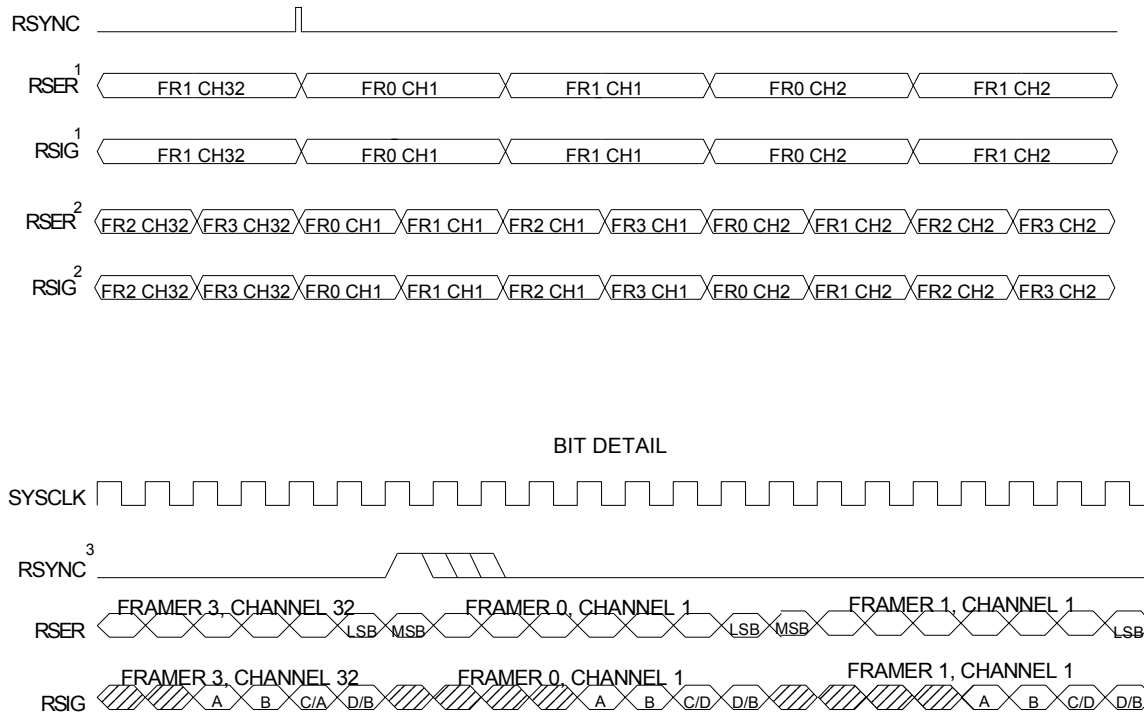

Notes:

1. 4.096 MHz bus configuration.
2. 8.192 MHz bus configuration.
3. RSYNC is in the input mode (RCR1.5 = 1).

Figure 22-6. RECEIVE SIDE, INTERLEAVED BUS OPERATION FRAME MODE TIMING

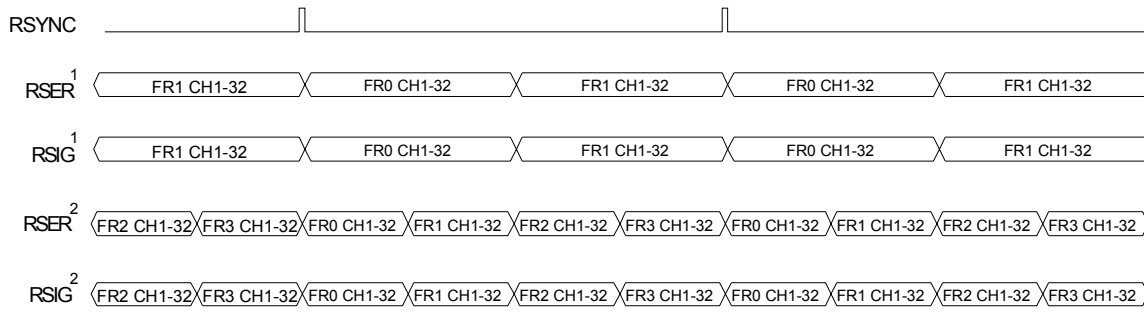

BIT DETAIL

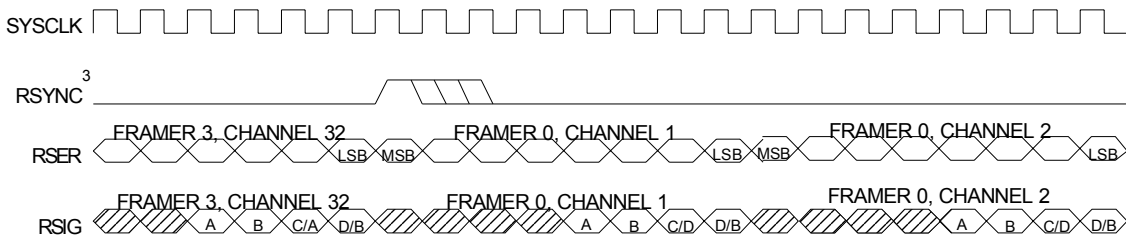

Notes:

1. 4.096 MHz bus configuration.
2. 8.192 MHz bus configuration.
3. RSYNC is in the input mode (RCR1.5 = 1).

Figure 22-7. TRANSMIT SIDE TIMING

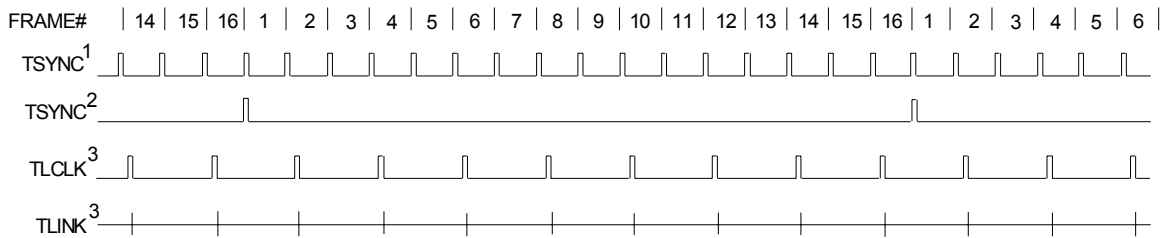

Notes:

1. TSYNC in the frame mode (TCR1.1 = 0)
2. TSYNC in the multiframe mode (TCR1.1 = 1)
3. TLINK is programmed to source just the Sa4 bit
4. This diagram assumes both the CAS MF and the CRC4 begin with the align frame

Figure 22-8. TRANSMIT SIDE BOUNDARY TIMING (With Elastic Store Disabled)

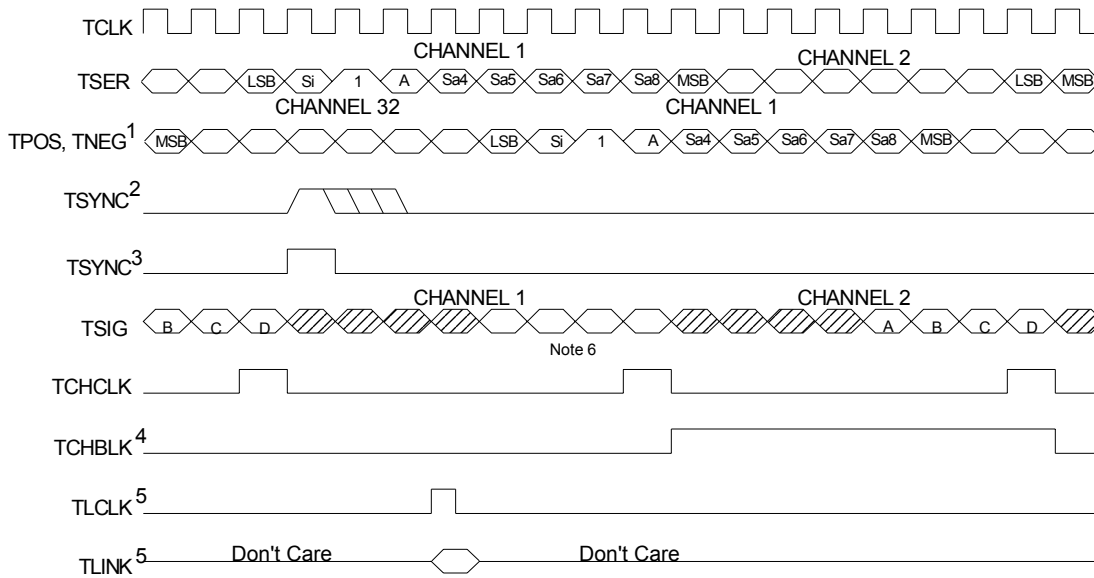

Notes:

1. There is a 5 TCLK delay from TSER to TPOS and TNEG
2. TSYNC is in the input mode (TCR1.0 = 0)
3. TSYNC is in the output mode (TCR1.0 = 1)
4. TCHBLK is programmed to block channel 2
5. TLINK is programmed to source the Sa4 bits
6. The signaling data at TSIG during channel 1 is normally overwritten in the transmit formatter with the CAS multiframe alignment nibble (0000)
7. Shown is a non-align frame boundary

Figure 22-9. TRANSMIT SIDE 1.544MHz BOUNDARY TIMING (With Elastic Store Enabled)

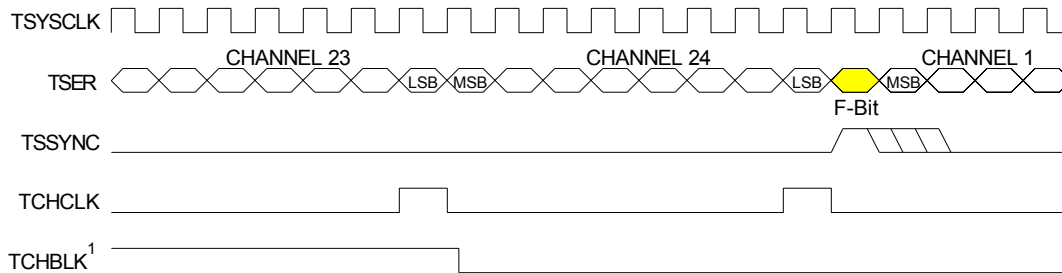

Notes:

1. TCHBLK is programmed to block channel 23
2. The F-bit position is ignored by the DS2154

Figure 22-10. TRANSMIT SIDE 2.048MHz BOUNDARY TIMING (With Elastic Store Enabled)

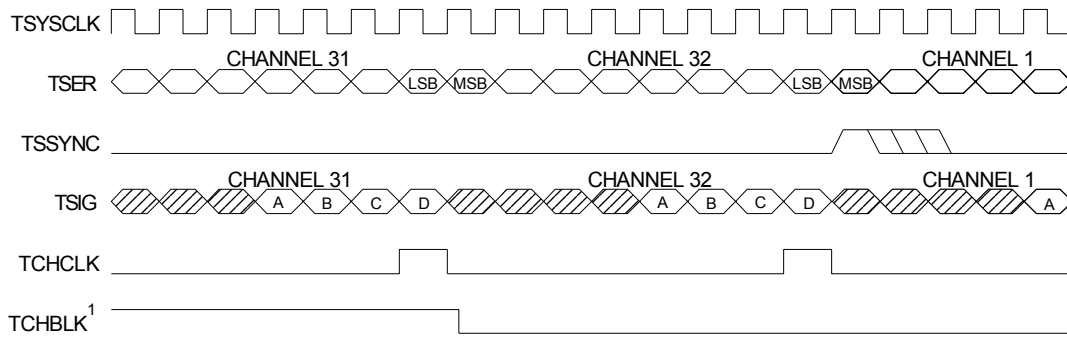

Notes:
1. TCHBLK is programmed to block channel 31

Figure 22-11. G.802 TIMING

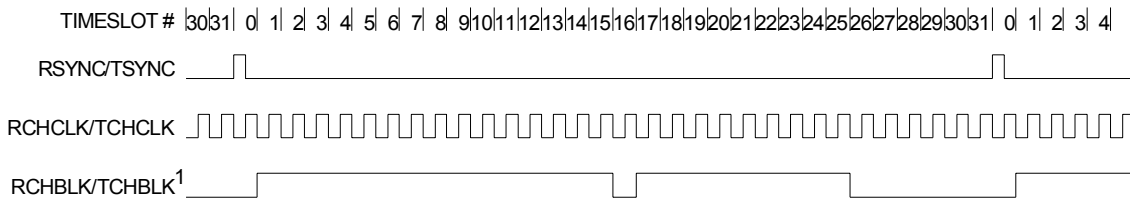

Notes:
1. RCHBLK or TCHBLK is programmed to pulse high during timeslots 1 to 15, 17 to 25, and during bit 1 of timeslot 26

detail

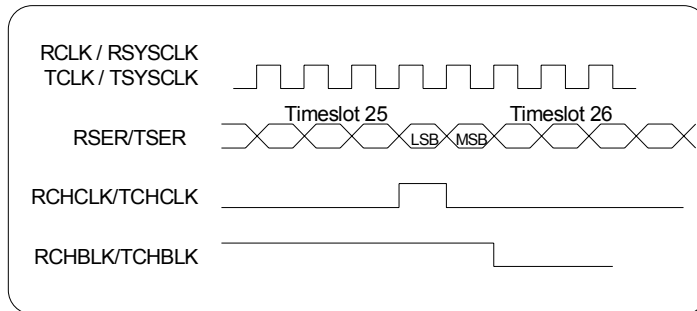
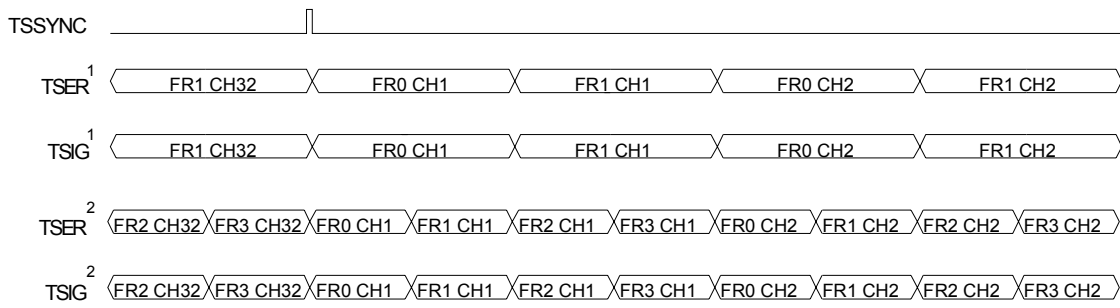
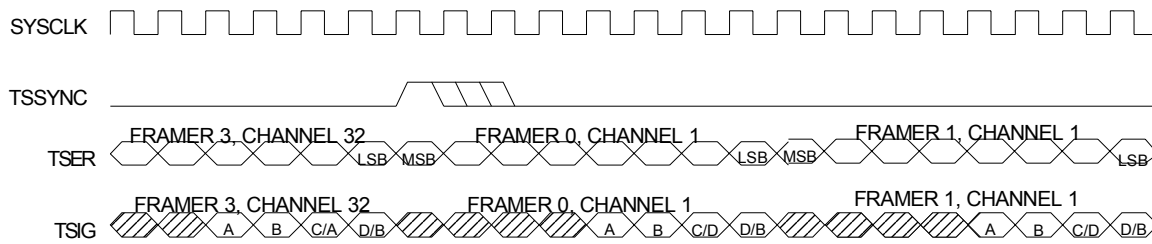

Figure 22-12. TRANSMIT SIDE, INTERLEAVED BUS OPERATION BYTE MODE TIMING



BIT DETAIL



Notes:

1. 4.096 MHz bus configuration.
2. 8.192 MHz bus configuration.

Figure 22-13. TRANSMIT SIDE INTERLEAVED BUS OPERATION FRAME MODE TIMING

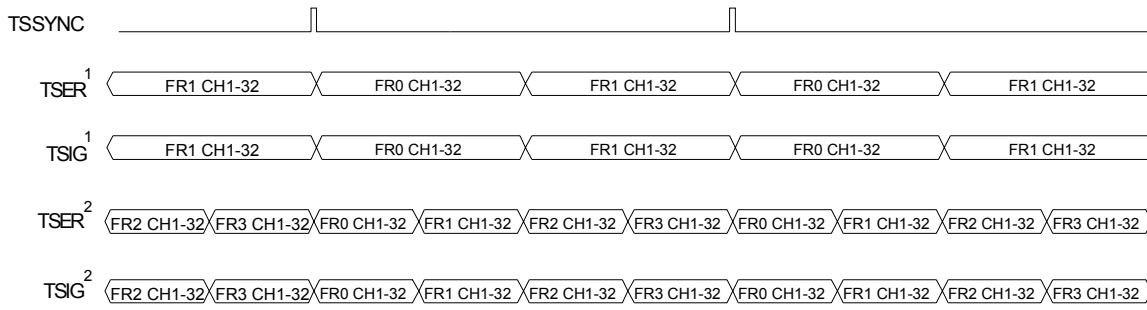

BIT DETAIL

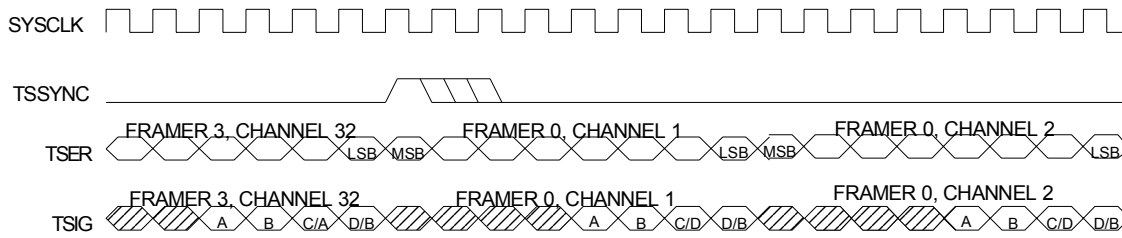

Notes:

1. 4.096 MHz bus configuration.
2. 8.192 MHz bus configuration.

Figure 22-14. DS21Q44 FRAMER SYNCHRONIZATION FLOWCHART

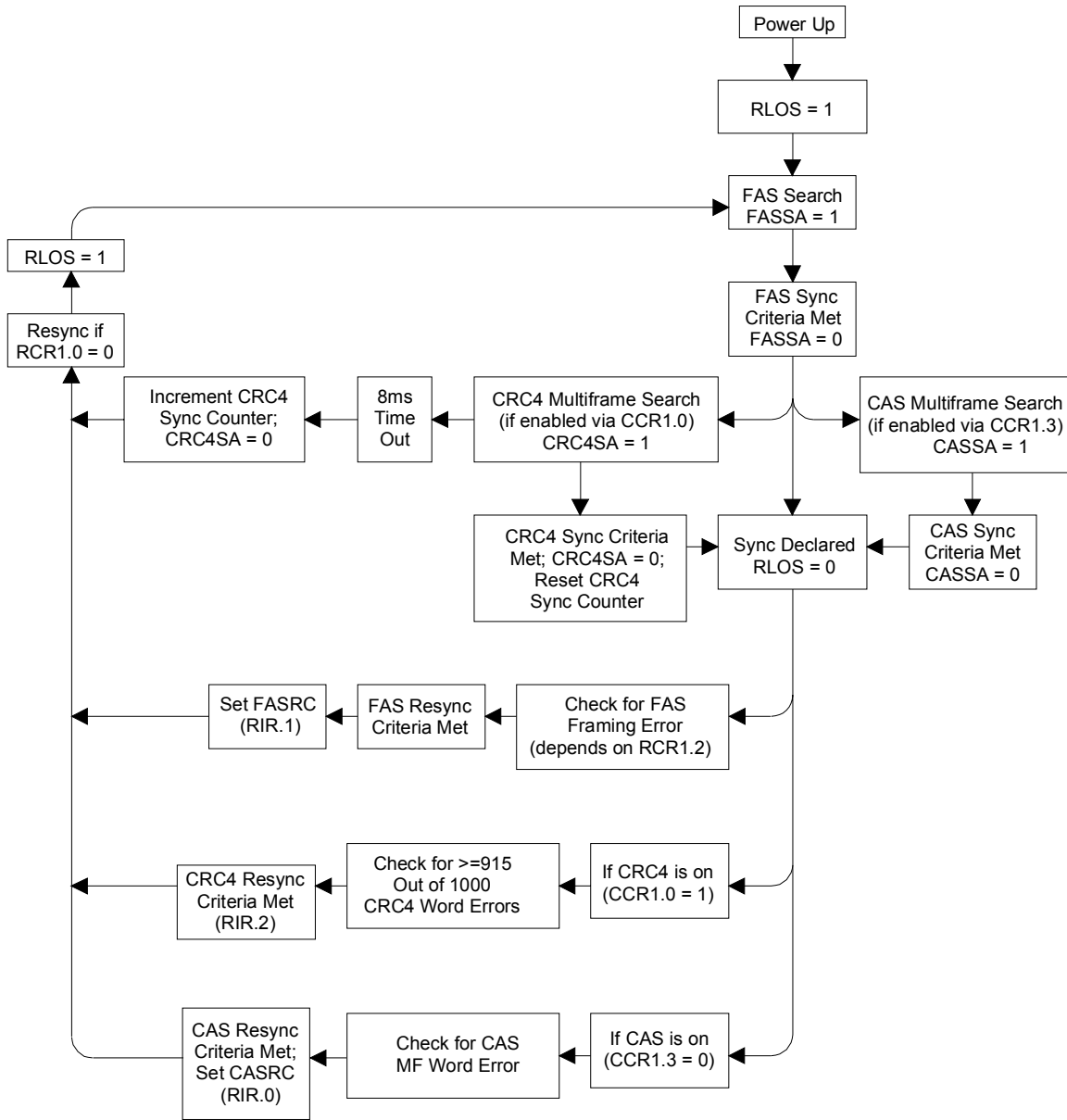
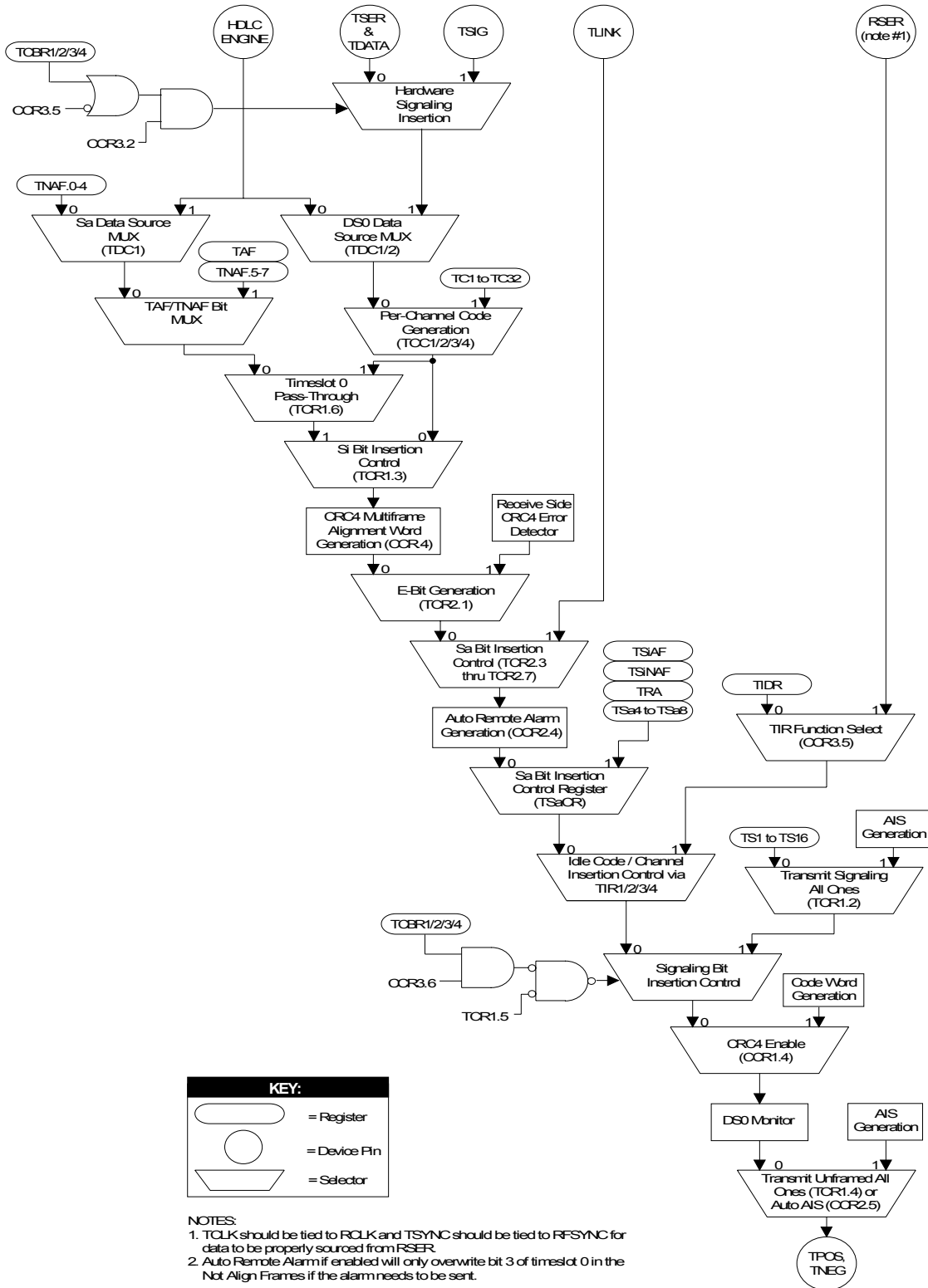

Figure 22-15. DS21Q44 TRANSMIT DATA FLOW



23. OPERATING PARAMETERS

ABSOLUTE MAXIMUM RATINGS*

Voltage Range on Any Non-Supply Pin Relative to Ground	-1.0V to +5.5V
Supply Voltage Range	-0.3V to +3.63V
Operating Temperature Range for DS21Q44T	0°C to +70°C
Operating Temperature Range for DS21Q44TN	-40°C to +85°C
Storage Temperature Range	-55°C to +125°C
Soldering Temperature Range	See IPC/JEDEC J-STD-020A

*This is a stress rating only and functional operation of the device at these or any other conditions beyond those indicated in the operation sections of this specification is not implied. Exposure to absolute maximum rating conditions for extended periods of time can affect reliability.

RECOMMENDED DC OPERATING CONDITIONS

($T_A = 0^\circ\text{C}$ to $+70^\circ\text{C}$ for DS21FF44/DS21FT44
 $T_A = -40^\circ\text{C}$ to $+85^\circ\text{C}$ for DS21FF44N/DS21FT44N)

PARAMETER	SYMBOL	MIN	TYP	MAX	UNITS	NOTES
Logic 1	V_{IH}	2.2		5.5	V	
Logic 0	V_{IL}	-0.3		+0.8	V	
Supply	V_{DD}	2.97		3.63	V	

CAPACITANCE

($T_A = +25^\circ\text{C}$)

PARAMETER	SYMBOL	MIN	TYP	MAX	UNITS	NOTES
Input Capacitance	C_{IN}		5		pF	
Output Capacitance	C_{OUT}		7		pF	

DC CHARACTERISTICS

($V_{DD} = 2.97$ to 3.63V , $T_A = 0^\circ\text{C}$ to $+70^\circ\text{C}$ for DS21FF44/DS21FT44
 $V_{DD} = 2.97$ to 3.63V , $T_A = -40^\circ\text{C}$ to $+85^\circ\text{C}$ for DS21FF44N/DS21FT44N)

PARAMETER	SYMBOL	MIN	TYP	MAX	UNITS	NOTES
Supply Current at 3.3V (DS21FT44)	I_{DD}		225		mA	1
Supply Current at 3.3V (DS21FF44)	I_{DD}		300		mA	1
Input Leakage	I_{IL}	-1.0		+1.0	μA	2
Output Leakage	I_{LO}			1.0	μA	3
Output Current (2.4V)	I_{OH}	-1.0			mA	
Output Current (0.4V)	I_{OL}	+4.0			mA	

NOTES:

- 1) $TCLK = RCLK = TSYCLK = RSYCLK = 2.048\text{MHz}$; outputs open-circuited.
- 2) $0.0\text{V} < V_{IN} < V_{DD}$
- 3) Applied to INT* when tri-stated.

AC CHARACTERISTICS—MULTIPLEXED PARALLEL PORT (MUX = 1)

($V_{DD} = 2.97$ to $3.63V$, $T_A = 0^{\circ}C$ to $+70^{\circ}C$ for DS21FF44/DS21FT44;
 $V_{DD} = 2.97$ to $3.63V$, $T_A = -40^{\circ}C$ to $+85^{\circ}C$ for DS21FF44N/DS21FT44N)

PARAMETER	SYMBOL	MIN	TYP	MAX	UNITS	NOTES
Cycle Time	t_{CYC}	200			ns	
Pulse Width, DS low or RD* high	PW_{EL}	100			ns	
Pulse Width, DS high or RD* low	PW_{EH}	100			ns	
Input Rise/Fall times	t_R, t_F			20	ns	
R/W* Hold Time	t_{RWH}	10			ns	
R/W* Setup time before DS high	t_{RWS}	50			ns	
CS*, FSO or FS1 Setup time before DS, WR* or RD* active	t_{CS}	20			ns	
CS*, FSO or FS1 Hold time	t_{CH}	0			ns	
Read Data Hold time	t_{DHR}	10		50	ns	
Write Data Hold time	t_{DHW}	10			ns	
Muxed Address valid to AS or ALE fall	t_{ASL}	15			ns	
Muxed Address Hold time	t_{AHL}	10			ns	
Delay time DS, WR* or RD* to AS or ALE rise	t_{ASD}	20			ns	
Pulse Width AS or ALE high	PW_{ASH}	30			ns	
Delay time, AS or ALE to DS, WR* or RD*	t_{ASED}	10			ns	
Output Data Delay time from DS or RD*	t_{DDR}	20		80	ns	
Data Setup time	t_{DSW}	50			ns	

See Figures 23-1 to 23-3 for details

AC CHARACTERISTICS—NONMULTIPLEXED PARALLEL PORT (MUX = 0)

($V_{DD} = 2.97$ to $3.63V$, $T_A = 0^\circ C$ to $+70^\circ C$ for DS21FF44/DS21FT44;
 $V_{DD} = 2.97$ to $3.63V$, $T_A = -40^\circ C$ to $+85^\circ C$ for DS21FF44N/DS21FTN44)

PARAMETER	SYMBOL	MIN	TYP	MAX	UNITS	NOTES
Setup Time for A0 to A7, FS0 or FS1 Valid to CS* Active	t_1	0			ns	
Setup Time for CS* Active to either RD*, WR*, or DS* Active	t_2	0			ns	
Delay Time from either RD* or DS* Active to Data Valid	t_3			75	ns	
Hold Time from either RD*, WR*, or DS* Inactive to CS* Inactive	t_4	0			ns	
Hold Time from CS* Inactive to Data Bus 3-state	t_5	5		50	ns	
Wait Time from either WR* or DS* Active to Latch Data	t_6	75			ns	
Data Setup Time to either WR* or DS* Inactive	t_7	15			ns	
Data Hold Time from either WR* or DS* Inactive	t_8	10			ns	
Address Hold from either WR* or DS* inactive	t_9	10			ns	

See Figures 23–4 to 23–7 for details.

AC CHARACTERISTICS—RECEIVE SIDE

($V_{DD} = 2.97$ to $3.63V$, $T_A = 0^{\circ}C$ to $+70^{\circ}C$ for DS21FF44/DS21FT44
 $V_{DD} = 2.97$ to $3.63V$, $T_A = -40^{\circ}C$ to $+85^{\circ}C$ for DS21FF44N/DS21FT44N)

PARAMETER	SYMBOL	MIN	TYP	MAX	UNITS	NOTES
RCLK Period	t_{CP}		488		ns	
RCLK Pulse Width	t_{CH} t_{CL}	75			ns	
RSYSCLK Period	t_{SP} t_{SP}	122	648 488		ns	1 2
RSYSCLK Pulse Width	t_{SH} t_{SL}	50			ns	
RSYNC Setup/Hold to RSYSCLK Falling	t_{SU} t_{HD}	20		$t_{SH} - 5$	ns	
RSYNC Pulse Width	t_{PW}	50			ns	
RPOS/RNEG Setup to RCLK Falling	t_{SU}	20			ns	
RPOS/RNEG Hold From RCLK Falling	t_{HD}	20			ns	
RSYSCLK/RCLKI Rise and Fall Times	t_R, t_F			25	ns	
Delay RCLK to RSER, RSIG, RLINK Valid	t_{D1}			50	ns	
Delay RCLK to RCHCLK, RSYNC, RCHBLK, RFSYNC, RLCLK	t_{D2}			50	ns	
Delay RSYSCLK to RSER, RSIG Valid	t_{D3}			50	ns	
Delay RSYSCLK to RCHCLK, RCHBLK, RMSYNC, RSYNC	t_{D4}			50	ns	

See Figures 23-8 to 23-10 for details.

NOTES:

- 1) RSYSCLK = 1.544MHz
- 2) RSYSCLK = 2.048MHz

AC CHARACTERISTICS—TRANSMIT SIDE

($V_{DD} = 2.97$ to $3.63V$, $T_A = 0^{\circ}C$ to $+70^{\circ}C$ for DS21FF44/DS21FT44
 $V_{DD} = 2.97$ to $3.63V$, $T_A = -40^{\circ}C$ to $+85^{\circ}C$ for DS21FF44N/DS21FT44N)

PARAMETER	SYMBOL	MIN	TYP	MAX	UNITS	NOTES
TCLK Period	t_{CP}		488		ns	
TCLK Pulse Width	t_{CH} t_{CL}	75			ns	
TCLKI Pulse Width	t_{LH} t_{LL}	75			ns	
TSYSCLK Period	t_{SP} t_{SP}	122	648 448		ns	1 2
TSYSCLK Pulse Width	t_{SH} t_{SL}	50			ns	
TSYNC or TSSYNC Setup/Hold to TCLK or TSYSCLK falling	t_{SU} t_{HD}	20		$t_{CH} - 5$ or $t_{SH} - 5$	ns	
TSYNC or TSSYNC Pulse Width	t_{PW}	50			ns	
TSER, TSIG, TLINK Setup to TCLK, TSYSCLK Falling	t_{SU}	20			ns	
TSER, TSIG, TLINK Hold from TCLK, TSYSCLK Falling	t_{HD}	20			ns	
TCLK or TSYSCLK Rise and Fall Times	t_R, t_F			25	ns	
Delay TCLK to TPOS, TNEG Valid	t_{DD}			50	ns	
Delay TCLK to TCHBLK, TCHCLK, TSYNC, TLCLK	t_{D2}			50	ns	
Delay TSYSCLK to TCHCLK, TCHBLK	t_{D3}			75	ns	

See Figures 23–11 to 23–13 for details.

NOTES:

- 1) TSYSCLK = 1.544MHz
- 2) TSYSCLK = 2.048MHz

Figure 23-1. INTEL BUS READ AC TIMING (BTS = 0 / MUX = 1)

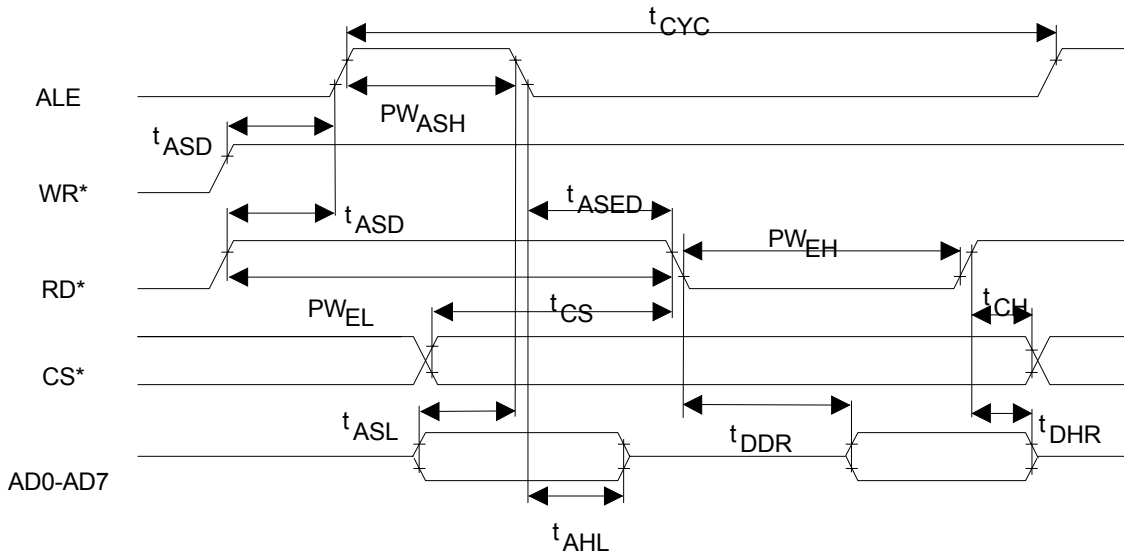

Figure 23-2. INTEL BUS WRITE TIMING (BTS = 1 / MUX = 1)

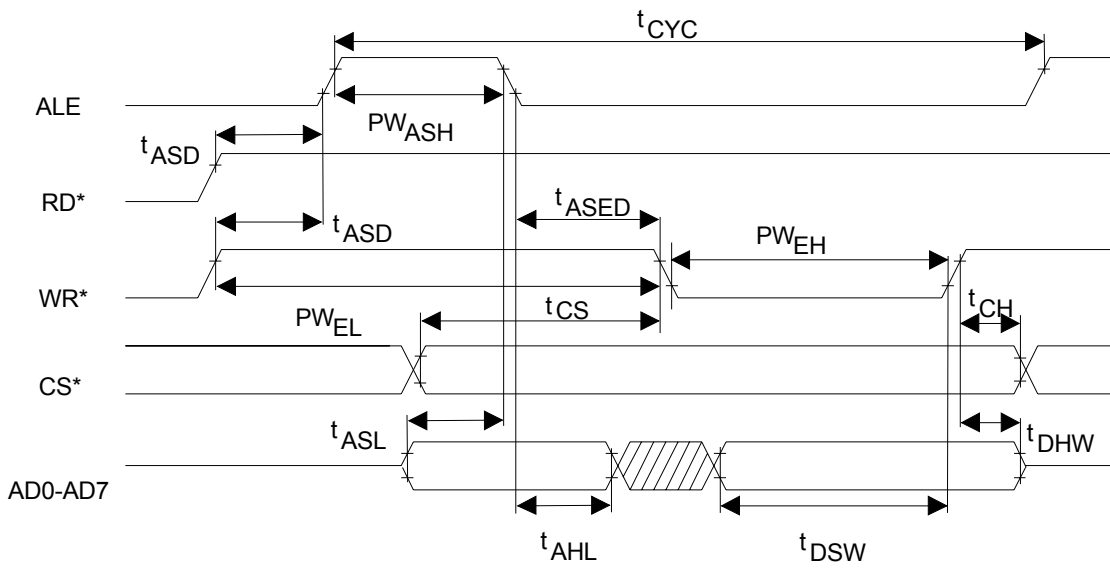

Figure 23-3. MOTOROLA BUS AC TIMING (BTS = 1 / MUX = 1)

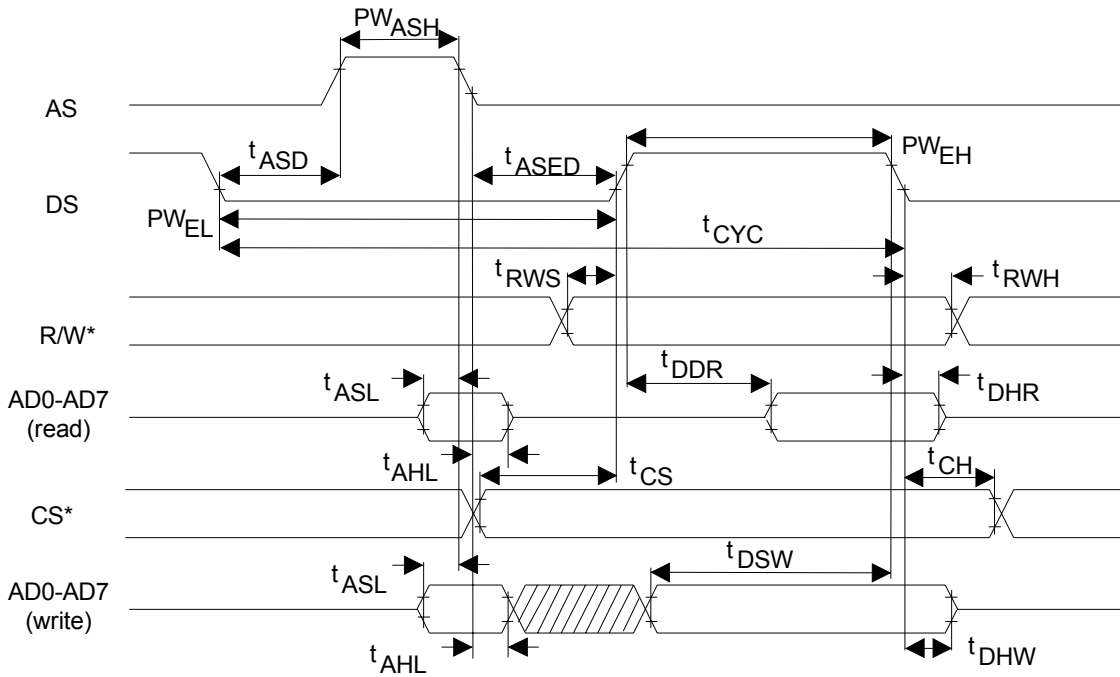

Figure 23-4. INTEL BUS READ AC TIMING (BTS = 0 / MUX = 0)

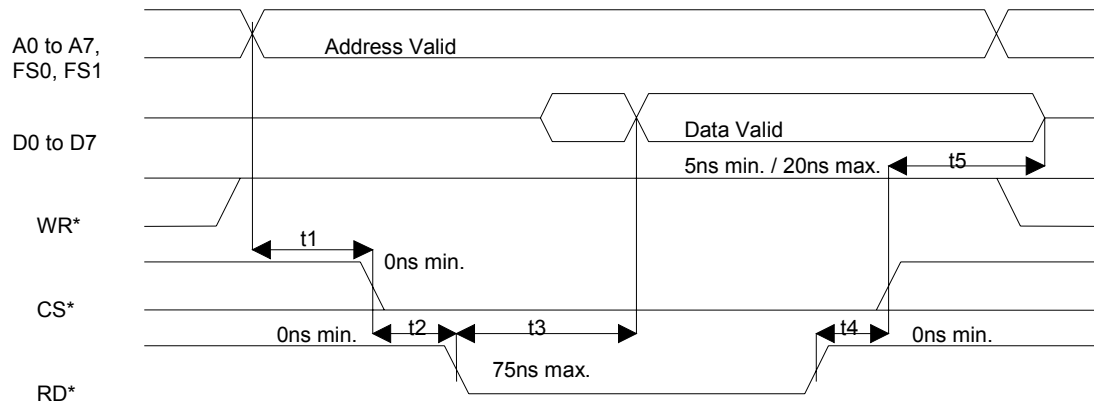

Figure 23-5. INTEL BUS WRITE AC TIMING (BTS = 0 / MUX = 0)

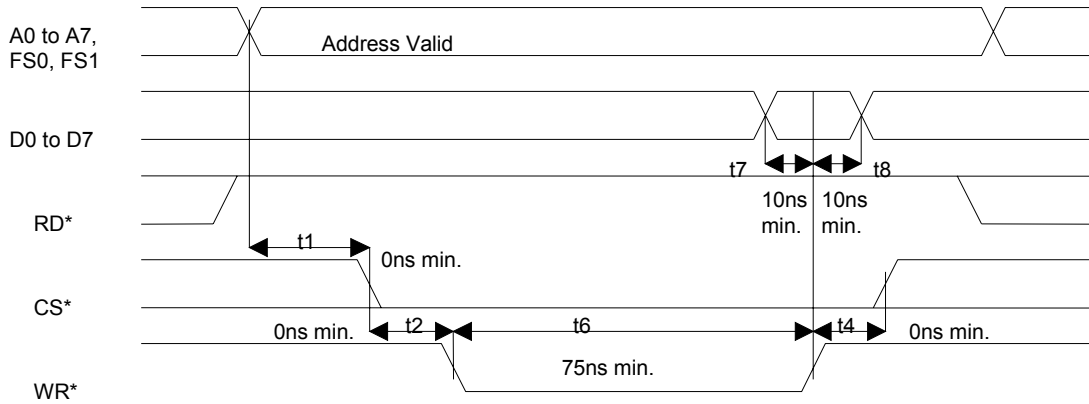
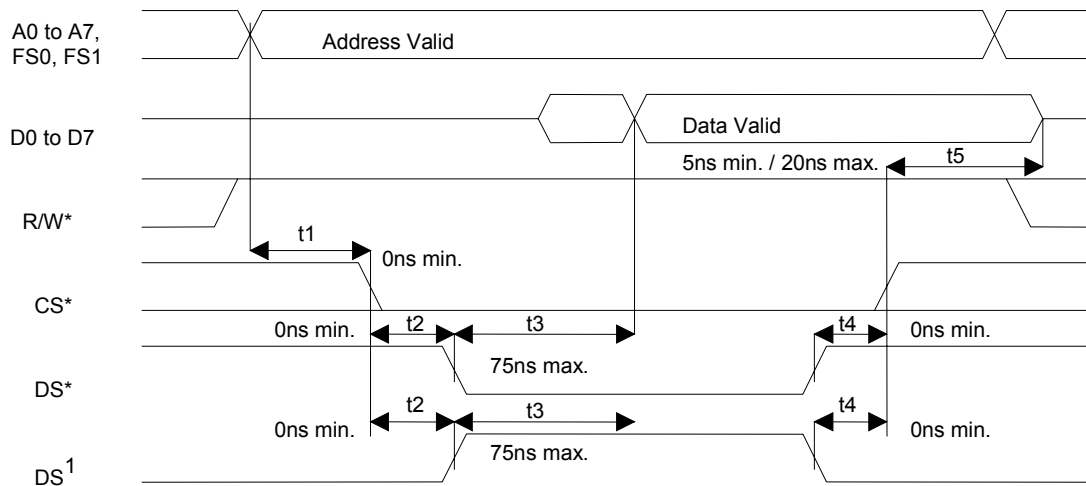
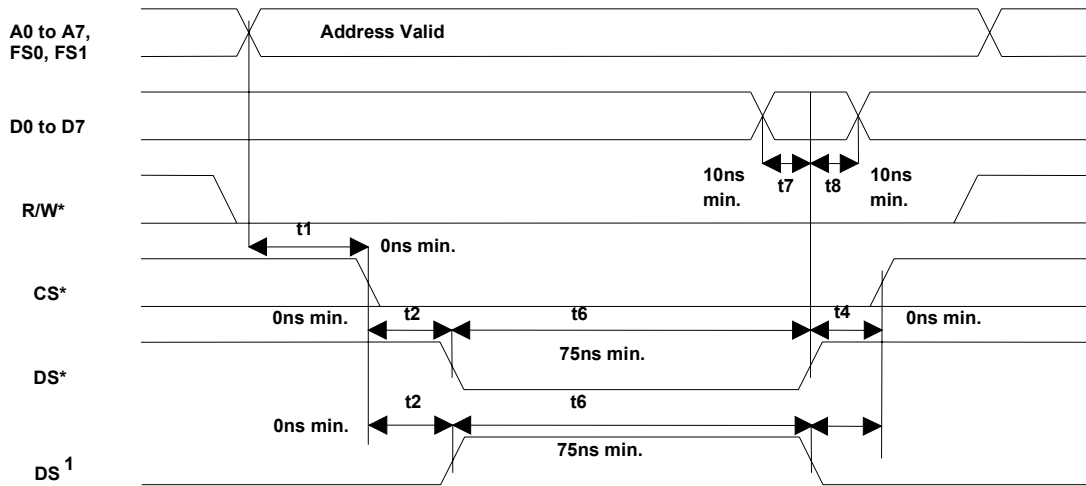

Figure 23-6. MOTOROLA BUS READ AC TIMING (BTS = 1 / MUX = 0)



Notes:

1. The signal DS is active high when emulating the DS21Q43 (FMS = 1).

Figure 23-7. MOTOROLA BUS WRITE AC TIMING (BTS = 1 / MUX = 0)**Notes:**

1. The signal DS is active high when emulating the DS21Q43 (FMS = 1) .

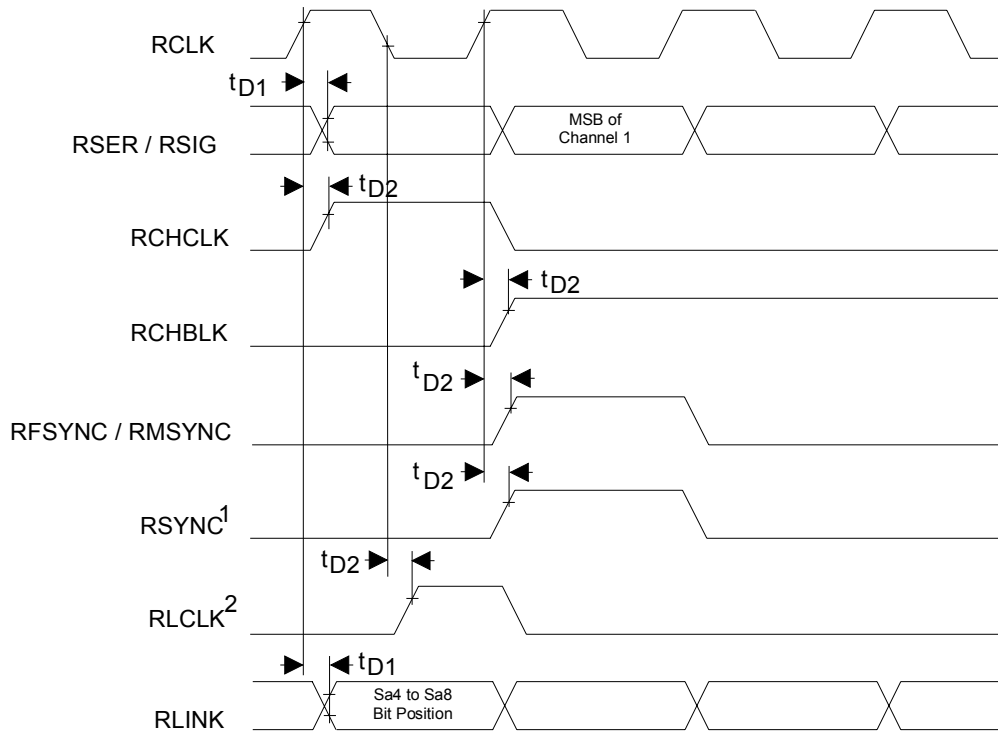
Figure 23-8. RECEIVE SIDE AC TIMING

Notes:

1. RSYNC is in the output mode (RCR1.5 = 0).
2. RLCLK will only pulse high during Sa bit locations as defined in RCR2; no relationship between RLCLK and RSYNC or RFSYNC is implied.

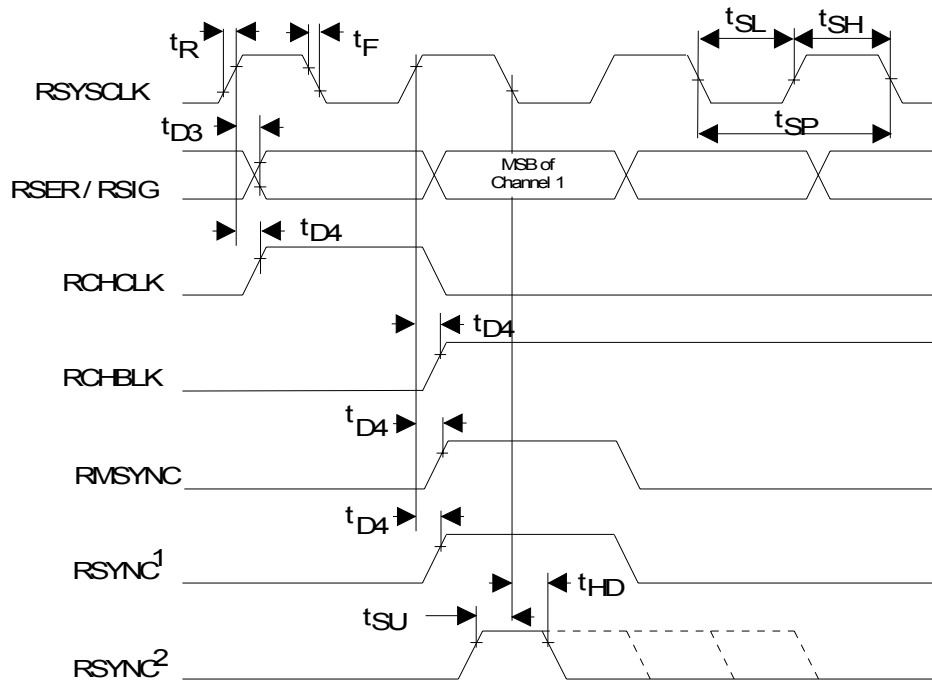
Figure 23-9. RECEIVE SYSTEM SIDE AC TIMING**Notes:**

1. RSYNC is in the output mode (RCR1.5 = 0)
2. RSYNC is in the input mode (RCR1.5 = 1)

Figure 23-10. RECEIVE LINE INTERFACE AC TIMING

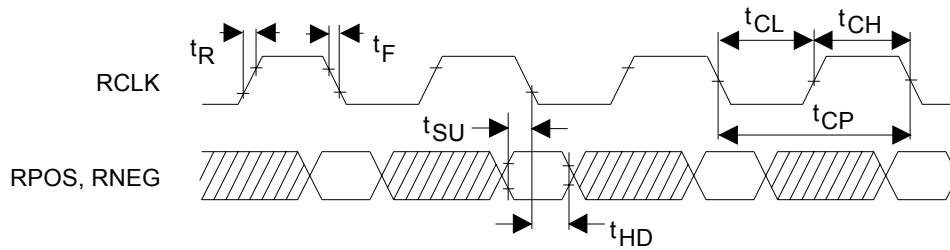
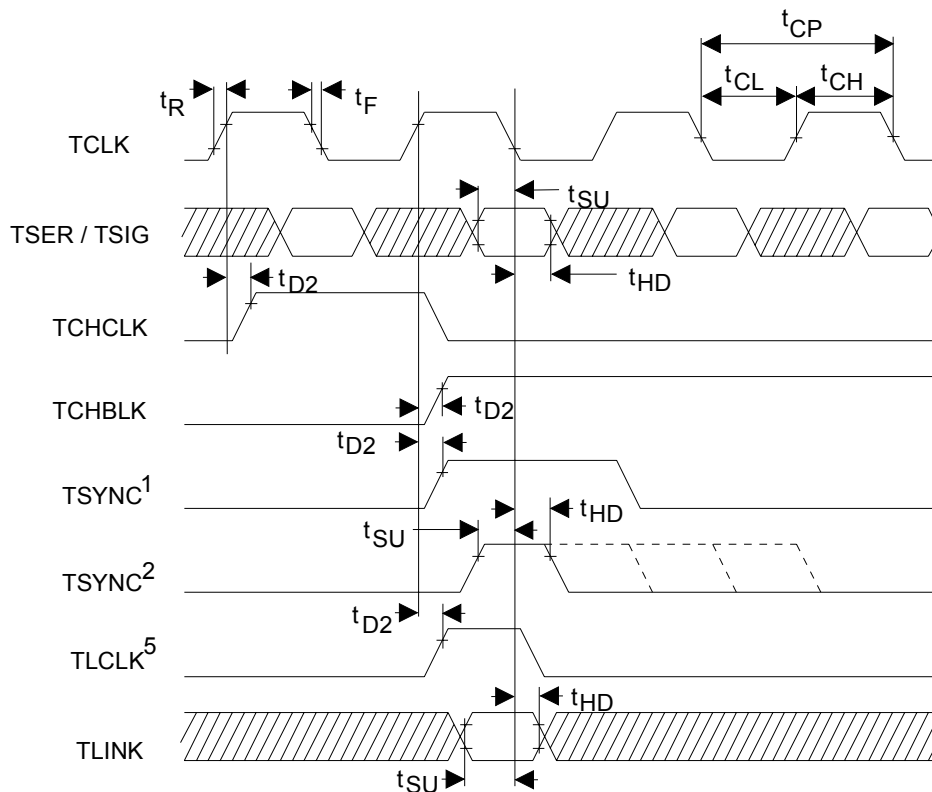
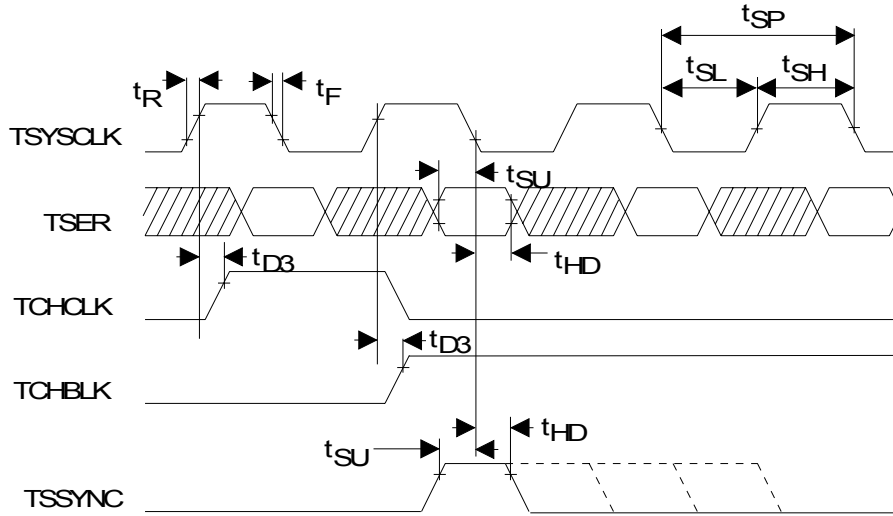

Figure 23-11. TRANSMIT SIDE AC TIMING



Notes:

1. TSYNC is in the output mode (TCR1.0 = 1).
2. TSYNC is in the input mode (TCR1.0 = 0).
3. TSER is sampled on the falling edge of TCLK when the transmit side elastic store is disabled.
4. TCHCLK and TCHBLK are synchronous with TCLK when the transmit side elastic store is disabled.
5. TLINK is only sampled during Sa bit locations as defined in TCR2; no relationship between TLCLK/TLINK and TSYNC is implied.

Figure 23-12. TRANSMIT SYSTEM SIDE AC TIMING**Notes:**

1. TSER is only sampled on the falling edge of TSYCLK when the transmit side elastic store is enabled.
2. TCHCLK and TCHBLK are synchronous with TSYCLK when the transmit side elastic store is enabled.

Figure 23-13. TRANSMIT LINE INTERFACE SIDE AC TIMING

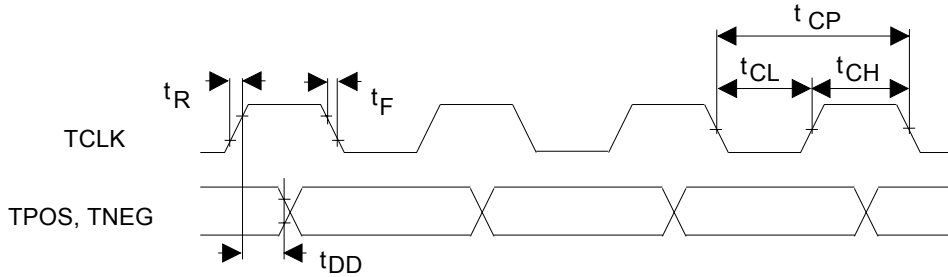

24. MCM PACKAGE DIMENSIONS

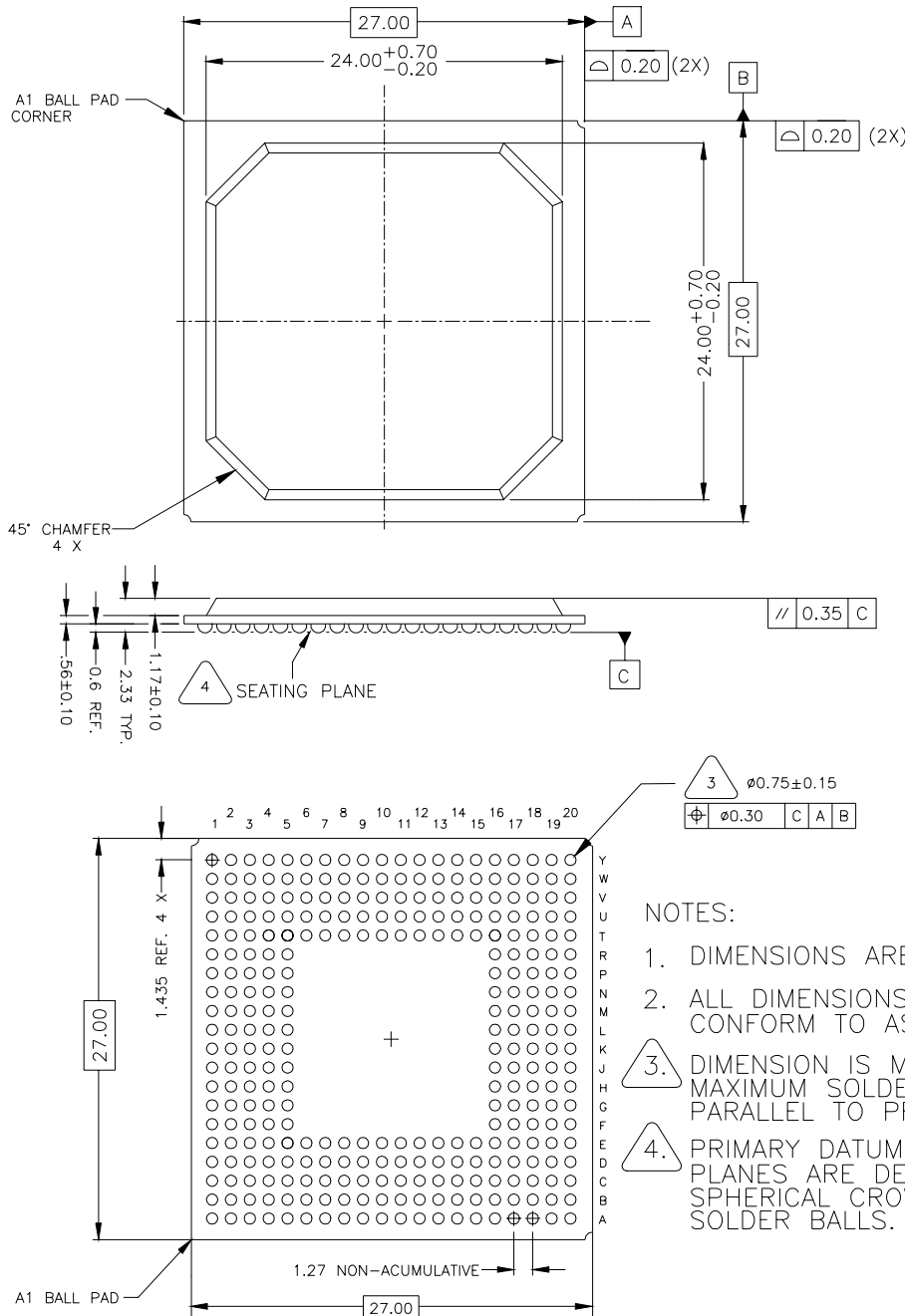

POWER SUPPLY DECOUPLING

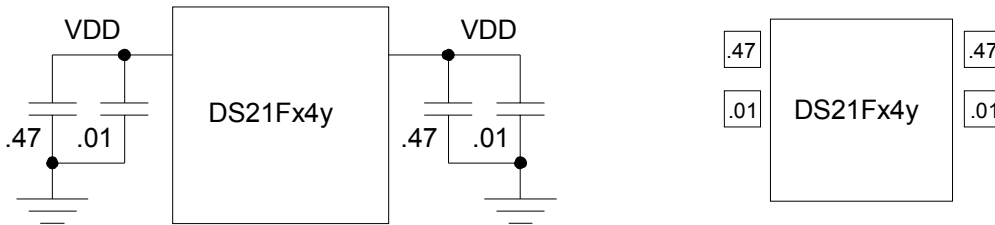

In a typical PCB layout for the MCM, all of the VDD pins will connect to a common power plane and all the VSS lines will connect to a common ground plane. The recommended method for decoupling is shown below in both schematic and pictorial form. As shown in the pictorial, the capacitors should be symmetrically located about the device. Figure 24-1 uses standard capacitors, two .47 uf ceramics and two .01uf ceramics. Since VDD and VSS signals will typically pass vertically to the power and ground planes of a PCB, the decoupling caps must be placed as close to the DS21Fx4y as possible and routed vertically to power and ground planes.

Figure 24-1. DECOUPLING SCHEME USING STANDARD TANTALUM CAPS



Looking for pricing, stock, or lifecycle information?

Click below to explore more details on WIN SOURCE:

-  [View DS21FT44N on WIN SOURCE](#)
-  [Maxim Integrated Information](#)

Optimize Your Supply Chain with WIN SOURCE Solutions

-  Global Sourcing Solution
-  Obsolete Management
-  Cost Control Management
-  Shortage Management
-  Alternative Solution
-  Excess Inventory Management