



**THE DATASHEET OF
DS2117MB/T&R**



FEATURES

- Fully Compliant with Ultra2, Ultra3, and Ultra 160/M SCSI
- Provides Multimode Low-Voltage Differential/Single-Ended (LVD/SE) Termination for Nine Signal Line Pairs
- Auto-Selection of LVD or SE Termination
- 5% Tolerance on SE and LVD Termination Resistance
- Low Power-Down Capacitance of 3pF
- On-Board Thermal Shutdown Circuitry
- SCSI Bus Hot Plug Compatible
- Fully Supports Actively Negated SE SCSI Signals

PIN CONFIGURATION

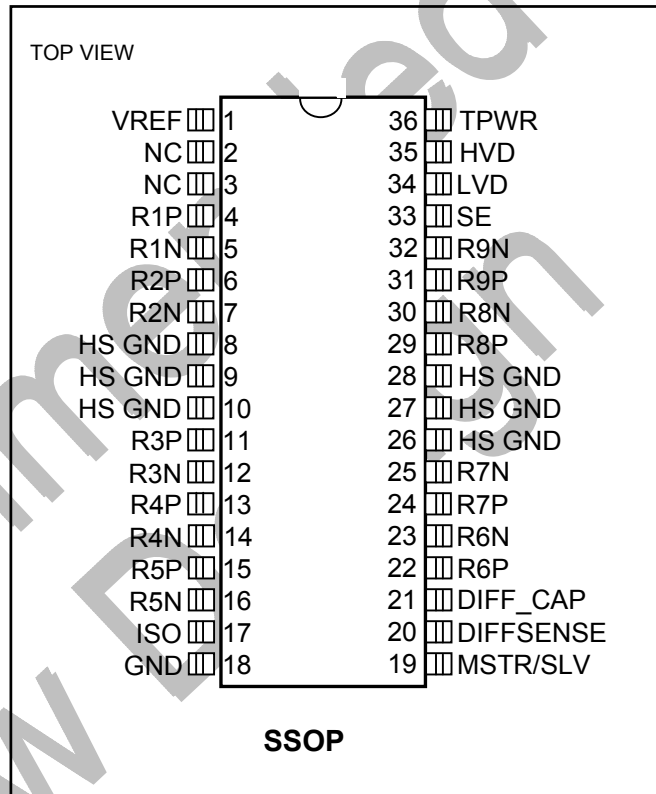

DESCRIPTION

The DS2117M Ultra3 LVD/SE SCSI terminator is both a low-voltage differential (LVD) and single-ended (SE) terminator. The multimode operation enables the designer to implement LVD in current products while allowing the end user SE-backward compatibility with legacy devices. If the device is connected in an LVD-only bus, the DS2117M uses LVD termination. If any SE devices are connected to the bus, the DS2117M uses SE termination. This is accomplished automatically inside the part by sensing the voltage on the SCSI bus DIFFSENS line.

For the LVD termination, the DS2117M integrates two current sources with nine precision resistor strings. For the SE termination, one regulator and nine precision 110Ω resistors are used. Three DS2117M terminators are needed for a wide SCSI bus.

REFERENCE DOCUMENTS

Small Computer Systems Interface (SCSI-3) SCSI Parallel Interface (SPI) Project: 0855-M, 1995
Small Computer Systems Interface (SCSI-3) SCSI Parallel Interface 2 (SPI-2) Project: 1142-M, 1998
Small Computer Systems Interface (SCSI-3) SCSI Parallel Interface 3 (SPI-3) Project: 1302-D, 1999
Small Computer Systems Interface (SCSI-3) SCSI Parallel Interface 4 (SPI-4) Project: 1365-D, xxxx

AVAILABLE FROM:

American National Standards Institute (ANSI) Phone: (212) 642-4900
Global Engineering Documents 15 Inverness Way East; Englewood, CO 80112 Phone: (800) 854-7179

FUNCTIONAL DESCRIPTION

The DS2117 combines LVD and SE termination with DIFFSENSE sourcing and detection.

A bandgap reference is fed into two amplifiers, which creates a 1.25V reference voltage and a 2.85V reference voltage. The control logic determines which of these references are applied to the termination resistors. If the SCSI bus is in LVD mode, the 1.25V reference is used. If the SCSI bus is in SE mode, the 2.85V reference is used. That same control logic switches in/out parallel resistors to change the total termination resistance accordingly. Finally, in SE mode the R_P pins are switched to ground.

The DIFFSENSE circuitry decodes trinary logic. There will be one of three voltages on the SCSI control line called DIFFSENS. Two comparators and a NAND gate determine if the voltage is below 0.6V, above 2.15V, or in between. That indicates the mode of the bus to be HVD, SE, or LVD, respectively.

The DS2117M's DIFF_CAP pin monitors the DIFFSENS line to determine the proper operating mode of the device; this mode is indicated by the SE/LVD/HVD outputs. The DIFFSENSE pin can also drive the SCSI DIFFSENS line (when MSTR/SLV = 1) to determine the SCSI bus operating mode. The DS2117M switches to the termination mode that is appropriate for the bus based on the value of the DIFFSENS voltage. These modes are LVD mode, SE mode, and HVD isolation mode.

LVD Mode

LVD termination is provided by a precision laser-trimmed resistor string with two current sources. This configuration yields a 105 Ω differential and 150 Ω common-mode impedance. A fail-safe bias of 112mV is maintained when no drivers are connected to the SCSI bus.

SE Mode

When the external driver for a given signal line turns off, the active terminator pulls that signal line to 2.85V (quiescent state). When used with an active negation driver, the power amp can sink 22mA per line while keeping the voltage reference in regulation. The terminating resistors maintain their 110 Ω value.

HVD Isolation Mode

The DS2117M identifies that there is an HVD (high voltage differential) device on the SCSI bus and isolates the termination pins from the bus.

When ISO is pulled high, the termination pins are isolated from the SCSI bus, V_{REF} is grounded, and the bus mode indicators (SE/LVD/HVD) remain active. During thermal shutdown, the termination pins are isolated from the SCSI bus, V_{REF} is grounded, and the bus mode indicators (SE/LVD/HVD) remain active. The DIFFSENSE driver is shut down during either of these two events.

To ensure proper operation, the TPWR pin should be connected to the SCSI bus TERMPWR line. As with all analog circuitry, the TERMPWR and V_{DD} lines should be bypassed locally. A $2.2\mu\text{F}$ capacitor and a $0.01\mu\text{F}$ high frequency capacitor are recommended between TPWR and ground and placed as close as possible to the DS2117M. The DS2117M should be placed as close as possible to the SCSI connector to minimize signal and power trace length, thereby resulting in less input capacitance and reflections which can degrade the bus signals.

To maintain the specified regulation, a $4.7\mu\text{F}$ capacitor is required between the V_{REF} pin (VREF) and ground of each DS2117M. A high frequency cap ($0.1\mu\text{F}$ ceramic recommended) can also be placed on the V_{REF} pin in applications that use fast rise/fall time drivers. A typical SCSI bus configuration is shown in Figure 2.

DIFFSENS NOISE FILTERING

The DS2117M incorporates a digital filter to remove high-frequency transients on the DIFFSENS control line, thereby eliminating erroneous switching between modes. This filter eliminates the need for the external capacitor and resistor, which heretofore performed this function. The external filter can be used in addition to the digital filter if the DS2117M and DS2118M are to be used interchangeably.

NOTE:

DIFFSENS—Refers to the SCSI bus signal.

DIFFSENSE—Refers to the DS2117M pin name and internal circuitry capable of driving the DIFFSENS line.

DIFF_CAP—Refers to the DS2117M pin name and internal circuitry relating to monitoring the DIFFSENS line.

Figure 1. DS2117M Block Diagram

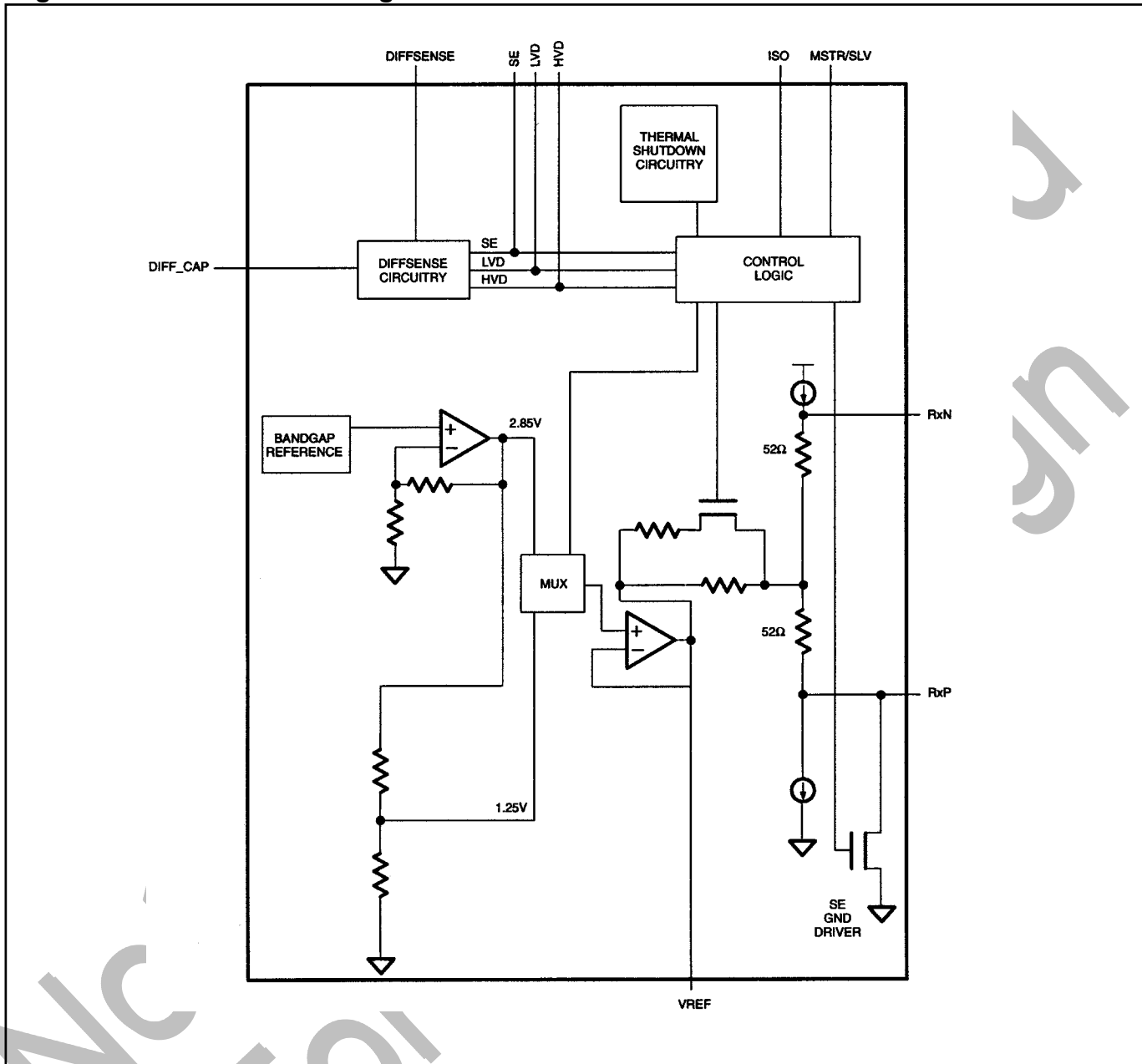
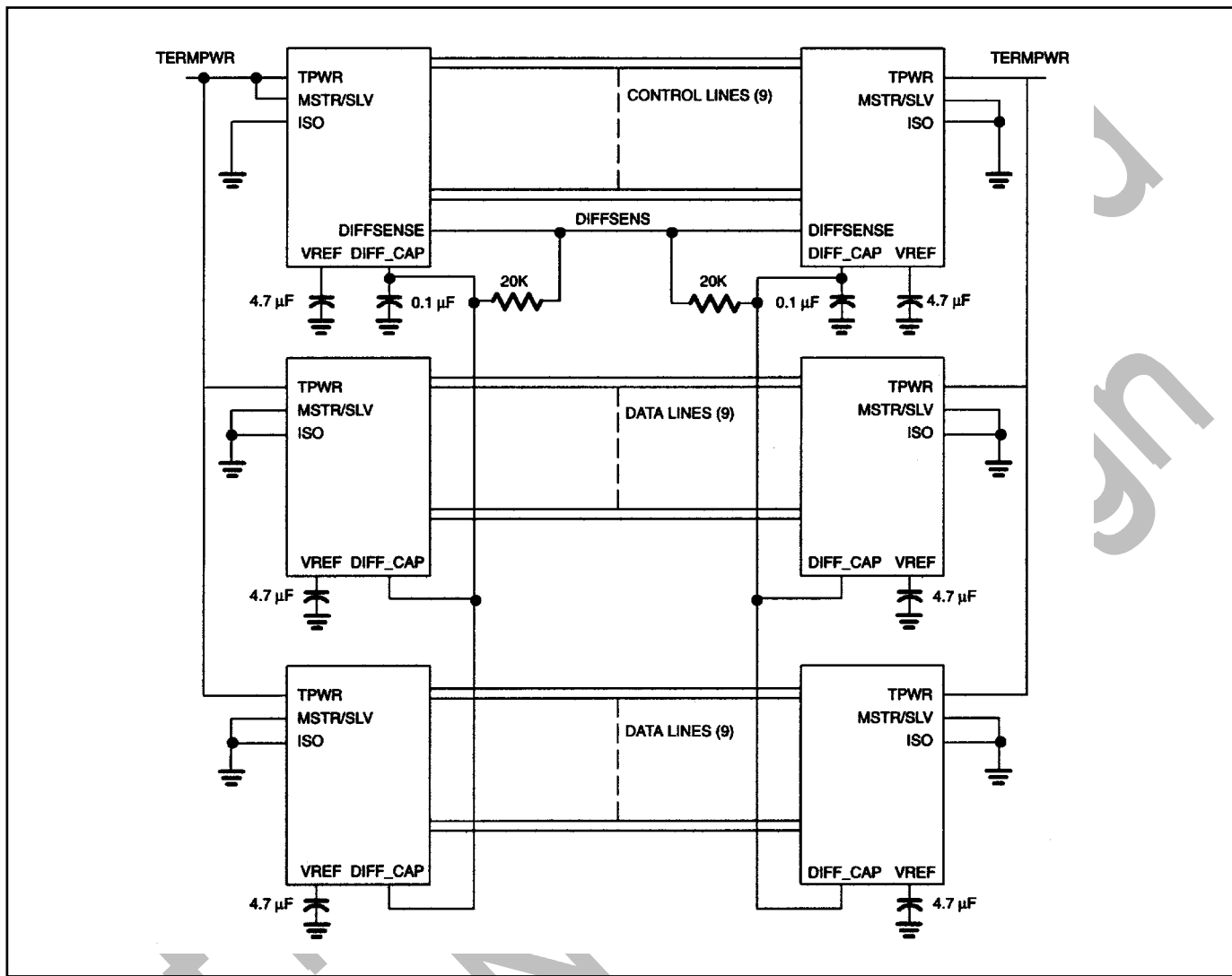

Figure 2. SCSI Bus Configuration



PIN DESCRIPTION

PIN	NAME	FUNCTION
1	VREF	Reference Voltage. 2.85V reference in SE mode and 1.25V reference in LVD mode; must be decoupled with a 4.7 μ F capacitor.
2, 3	NC	No Connection. Do not connect these pins.
4–7, 11–16, 22–25, 29–32	RxP, RxN	Signal Termination. Connect to SCSI bus signal lines.
8, 9, 10, 26, 27, 28	HS GND	Heat Sink Ground. Internally connected to the mounting pad. Should be grounded.
17	ISO	Isolation. When pulled high, the DS2117M isolates its bus pins (RxP, RxN) from the SCSI bus.
18	GND	Ground. Signal ground, 0V.
19	MSTR/SLV	Master/Slave. Mode select for the non-controlling terminator. When pulled high (MSTR), the DIFFSENSE driver is enabled.
20	DIFFSENSE	DIFFSENSE. Output to drive the SCSI bus DIFFSENS line.
21	DIFF_CAP	DIFFSENSE Capacitor. Connect 0.1 μ F capacitor for DIFFSENSE filter. Input to detect the type of device (differential or single-ended) on the SCSI bus.
33	SE	Single-Ended. SE output of DIFFSENSE receiver; output high indicates SE bus operation.
34	LVD	Low-Voltage Differential. LVD output of DIFFSENSE receiver; output high indicates LVD bus operation.
35	HVD	High-Voltage Differential. HVD output of DIFFSENSE receiver; output high indicates HVD bus operation or thermal shutdown.
36	TPWR	Termination Power. Connect to the SCSI TERMPWR line and decouple with 2.2 μ F capacitor.

RECOMMENDED OPERATING CONDITIONS

PARAMETER	SYMBOL	MIN	TYP	MAX	UNITS	NOTES	
Termpower Voltage	SE Mode	$V_{TPWR(SE)}$	4.0		5.5	V	
	LVD Mode	$V_{TPWR(LVD)}$	2.7		5.5	V	
Logic 0	V_{IL}	-0.3		+0.8	V		
Logic 1	V_{IH}	2.0		$V_{TPWR} + 0.3$	V		
Operating Temperature	V_{AMB}	0		70	°C		

SINGLE-ENDED CHARACTERISTICS

PARAMETER	SYMBOL	MIN	TYP	MAX	UNITS	NOTES
SE Termination Resistance	R_{SE}	104.5	110	115.5	Ω	1
SE Voltage Reference	V_{REF}	2.7		3.0	V	
SE Output Current	I_{LOSE}			25.4	mA	2
Output Capacitance	C_{OUT}			3	pF	3

LOW-VOLTAGE DIFFERENTIAL CHARACTERISTICS

PARAMETER	SYMBOL	MIN	TYP	MAX	UNITS	NOTES
Differential-Mode Termination Resistance	R_{DM}	100		110	Ω	
Common-Mode Termination Resistance	R_{CM}	110		190	Ω	
Differential-Mode Bias	V_{DM}	100		125	mV	4
Common-Mode Bias	V_{CM}	1.125		1.375	V	

DC CHARACTERISTICS

PARAMETER	SYMBOL	MIN	TYP	MAX	UNITS	NOTES
Termpower Current	I_{TPMR}		12		mA	4
Input Leakage High	I_{IH}	-1.0			μ A	
Input Leakage Low	I_{IL}			1.0	μ A	
Output Current High	I_{OH}	-1.0			mA	5, 7
Output Current Low	I_{OL}	4.0			mA	6, 7
DIFFSENS SE Operating Range	V_{SEOR}	-0.3		+0.5	V	
DIFFSENS LVD Operating Range	V_{LVDOR}	0.7		1.9	V	
DIFFSENS HVD Operating Range	V_{HVDOR}	2.4		$V_{TPWR} + 0.3$	V	
DIFFSENSE Driver Output Voltage	V_{DSO}	1.2		1.4	V	8, 9
DIFFSENSE Driver Source Current	I_{DSH}	5		15	mA	8, 10, 12
DIFFSENSE Driver Sink Current	I_{DSL}	20		200	μ A	8, 11
Thermal Shutdown			150		°C	3

REGULATOR CHARACTERISTICS

PARAMETER	SYMBOL	MIN	TYP	MAX	UNITS	NOTES
Line Regulation	L_{REG}		1.0	2.5	%	
Load Regulation	L_{OREG}		1.3	3.5	%	
Current Limit	I_{LIM}		550		mA	
Sink Current	I_{SINK}	200			mA	

NOTES:

- 1) $V_{LINE} = 0$ to 3.0V.
- 2) $V_{LINE} = 0.2$ V.
- 3) Guaranteed by design.
- 4) All lines open.
- 5) $V_{OUT} = 2.4$ V.
- 6) $V_{OUT} = 0.4$ V.
- 7) SE/LVD/HVD pins only.
- 8) MSTR/SLV = 1.
- 9) $I_{DS} = 0$ to 5mA.
- 10) $V_{DSO} = 0$ V.
- 11) $V_{DSO} = 2.75$ V.
- 12) TPWR = 5.5V

DS2117M 36-PIN SSOP PACKAGE

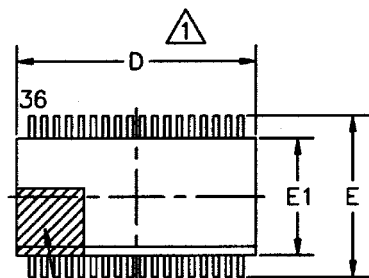

1 DIMENSIONS D AND E1 INCLUDE MOLD MISMATCH, BUT DO NOT INCLUDE MOLD FLASH, PROTRUSIONS OR GATE BURRS. MOLD FLASH, PROTRUSIONS OR GATE BURRS SHALL NOT EXCEED 0.254mm PER SIDE.

2 SECTION A-A DIMENSIONS APPLY TO THE FLAT SECTION OF THE LEAD BETWEEN 0.13mm TO 0.25mm FROM THE LEAD TIP.

3 THE CHAMFER ON THE BODY IS OPTIONAL. IF IT IS NOT PRESENT, A VISUAL INDEX FEATURE MUST BE LOCATED WITHIN THE CROSS-HATCHED AREA.

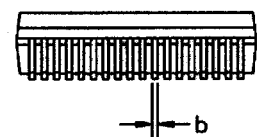
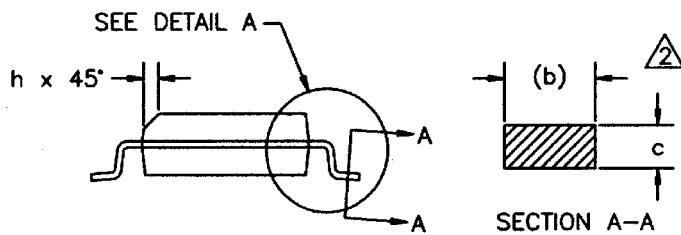
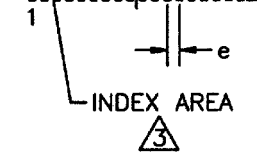

DIM	MIN	MAX
A	2.44	2.64
A1	0.12	-
b	0.29	0.43
c	0.23	0.32
D	15.20	15.54
E	10.11	10.52
E1	7.40	7.60
e	0.80 BSC	
h	0.25	0.71
L	0.51	1.02

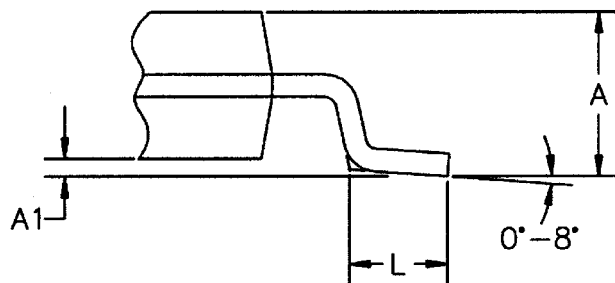



DETAIL A

DIMENSIONS ARE IN MILLIMETERS

Looking for pricing, stock, or lifecycle information?

Click below to explore more details on WIN SOURCE:

-  [View DS2117MB/T&R on WIN SOURCE](#)
-  [Maxim Integrated Information](#)

Optimize Your Supply Chain with WIN SOURCE Solutions

-  Global Sourcing Solution
-  Obsolete Management
-  Cost Control Management
-  Shortage Management
-  Alternative Solution
-  Excess Inventory Management