



**THE DATASHEET OF
DS1876T+T&R**



SFP Controller with Dual LDD Interface

General Description

The DS1876 controls and monitors all functions for dual transmitter modules. The memory map is based on SFF-8472. The DS1876 supports APC and modulation control and eye safety functionality for two laser drivers. It continually monitors for high output current, high bias current, and low and high transmit power to ensure that laser shutdown for eye safety requirements are met without adding external components. Six ADC channels monitor VCC, temperature, and four external monitor inputs that can be used to meet all monitoring requirements.

Applications

Dual Tx Video SFP Modules

Ordering Information

PART	TEMP RANGE	PIN-PACKAGE
DS1876T+	-40°C to +95°C	28 TQFN-EP*
DS1876T+T&R	-40°C to +95°C	28 TQFN-EP*

+Denotes a lead(Pb)-free/RoHS-compliant package.

T&R = Tape and reel.

*EP = Exposed pad.

Features

- ◆ Meets All SFF-8472 Transmitter Control and Monitoring Requirements
- ◆ Six Analog Monitor Channels: Temperature, VCC, PMON1, BMON1, PMON2, BMON2
PMON_ and BMON_ Support Internal and External Calibration
Scalable Dynamic Range
Internal Direct-to-Digital Temperature Sensor
Alarm and Warning Flags for All Monitored Channels
- ◆ Six Quick Trips for Fast Monitoring of Critical Functions for Laser Safety
- ◆ Four 10-Bit Delta-Sigma Outputs
Each Controlled by 72-Entry Temperature Lookup Table (LUT)
- ◆ Digital I/O Pins: Six Inputs, Five Outputs
- ◆ Comprehensive Fault Measurement System with Maskable Laser Shutdown Capability
- ◆ Flexible, Two-Level Password Scheme Provides Three Levels of Security
- ◆ 256 Additional Bytes Located at A0h Slave Address
- ◆ Transmitter 1 is Accessed at A2h Slave Address
- ◆ Transmitter 2 is Accessed at B2h Slave Address
- ◆ I²C-Compatible Interface
- ◆ +2.85V to +3.9V Operating Voltage Range
- ◆ -40°C to +95°C Operating Temperature Range
- ◆ 28-Pin TQFN (5mm x 5mm x 0.8mm) Package

DS1876

SFP Controller with Dual LDD Interface

TABLE OF CONTENTS

Absolute Maximum Ratings	5
Recommended Operating Conditions	5
DC Electrical Characteristics	5
MOD_, APC_ Electrical Characteristics	6
Analog Quick-Trip Characteristics	6
Analog Voltage Monitoring Characteristics	6
Digital Thermometer Characteristics	7
AC Electrical Characteristics	7
Quick-Trip Timing Characteristics	7
I ² C AC Electrical Characteristics	7
Nonvolatile Memory Characteristics	8
Typical Operating Characteristics	9
Pin Configuration	10
Pin Description	10
Block Diagram	11
Typical Operating Circuit	12
Detailed Description	12
DACs During Power-Up	12
DACs as a Function of Transmit Disable (TXD1, TXD2)	13
Quick-Trip Timing	13
Monitors and Fault Detection	14
Monitors	14
Six Quick-Trip Monitors and Alarms	14
Six ADC Monitors and Alarms	14
ADC Timing	15
Right-Shifting ADC Result	15
Low-Voltage Operation	15
Delta-Sigma Outputs	16
Digital I/O Pins	18
IN1, RSEL, OUT1, RSELOUT	18
TXF1, TXF2, TXFOUT, TXD1, TXD2, TXDOUT1, TXDOUT2	18
Transmit Fault (TXFOUT) Output	19
Die Identification	19
I ² C Communication	19
I ² C Definitions	19
I ² C Protocol	21

SFP Controller with Dual LDD Interface

TABLE OF CONTENTS (continued)

Memory Organization	22
Shadowed EEPROM	23
Register Descriptions	24
Memory Map Access Codes	24
Memory Addresses A0h, A2h, and B2h	24
Lower Memory Register Map	25
Table 01h Register Map	25
Table 02h Register Map	26
Table 04h Register Map	26
Table 05h Register Map	27
Table 06h Register Map	27
Auxiliary Memory A0h Register Map	27
Lower Memory Register Descriptions	28
Table 01h Register Descriptions	40
Table 02h Register Descriptions	44
Table 04h Register Descriptions	64
Table 06h Register Descriptions	65
Auxiliary Memory A0h Register Descriptions	68
Applications Information	69
Power-Supply Decoupling	69
SDA and SCL Pullup Resistors	69
Package Information	69

DS1876

SFP Controller with Dual LDD Interface

LIST OF FIGURES

Figure 1. Power-Up Timing	13
Figure 2. TXD1, TXD2 Timing	13
Figure 3. Quick-Trip Sample Timing	14
Figure 4. ADC Round-Robin Timing	15
Figure 5. Low-Voltage Hysteresis Example	16
Figure 6. Recommended RC Filter for DAC Outputs in Voltage Mode and Current Sink Mode	16
Figure 7. 3-Bit (8-Position) Delta-Sigma Example	17
Figure 8. DAC OFFSET LUTs	17
Figure 9. Logic Diagram 1	18
Figure 10. Logic Diagram 2	18
Figure 11a. TXFOUT Nonlatched Operation	19
Figure 11b. TXFOUT Latched Operation	19
Figure 12. I ² C Timing	20
Figure 13. Example I ² C Timing	21
Figure 14. Memory Map	23

LIST OF TABLES

Table 1. Acronyms	13
Table 2. ADC Default Monitor Full-Scale Ranges	14

SFP Controller with Dual LDD Interface

ABSOLUTE MAXIMUM RATINGS

Voltage Range on PMON_, BMON_, RSEL, IN1, TXF_, and TXD_ Pins
 Relative to Ground -0.5V to (VCC + 0.5V)*

Voltage Range on VCC, SDA, SCL, OUT1, RSELOUT, and TXFOUT Pins
 Relative to Ground -0.5V to +6V

Continuous Power Dissipation
 28-Pin TQFN (derate 34.5mW/°C) above +70°C....2758.6mW

Operating Temperature Range -40°C to +95°C

Programming Temperature Range 0°C to +95°C

Storage Temperature Range..... -55°C to +125°C

Soldering Temperature Refer to the IPC/JEDEC J-STD-020 Specification.

*Subject to not exceeding +6V.

Stresses beyond those listed under "Absolute Maximum Ratings" may cause permanent damage to the device. These are stress ratings only, and functional operation of the device at these or any other conditions beyond those indicated in the operational sections of the specifications is not implied. Exposure to absolute maximum rating conditions for extended periods may affect device reliability.

RECOMMENDED OPERATING CONDITIONS

(T_A = -40°C to +95°C, unless otherwise noted.)

PARAMETER	SYMBOL	CONDITIONS	MIN	TYP	MAX	UNITS
Main Supply Voltage	VCC	(Note 1)	+2.85		+3.9	V
High-Level Input Voltage (SDA, SCL)	V _{IH:1}		0.7 x VCC		VCC + 0.3	V
Low-Level Input Voltage (SDA, SCL)	V _{IL:1}		-0.3		0.3 x VCC	V
High-Level Input Voltage (TXD_, TXF_, RSEL, IN1)	V _{IH:2}		2.0		VCC + 0.3	V
Low-Level Input Voltage (TXD_, TXF_, RSEL, IN1)	V _{IL:2}		-0.3		+0.8	V

DC ELECTRICAL CHARACTERISTICS

(VCC = +2.85V to +3.9V, T_A = -40°C to +95°C, unless otherwise noted.)

PARAMETER	SYMBOL	CONDITIONS	MIN	TYP	MAX	UNITS
Supply Current	I _{CC}	(Notes 1, 2)		2.5	10	mA
Output Leakage (SDA, OUT1, RSELOUT, TXFOUT)	I _{LO}				1	µA
Low-Level Output Voltage (SDA, OUT1, RSELOUT, TXDOUT_, MOD_, APC_, TXFOUT)	V _{OL}	I _{OL} = 4mA			0.4	V
		I _{OL} = 6mA			0.6	
High-Level Output Voltage (MOD_, APC_, TXDOUT_)	V _{OH}	I _{OH} = 4mA	VCC - 0.4			V
TXDOUT_ Before EEPROM Recall				10	100	nA
MOD_, APC_ Before Recall		Figure 1		10	100	nA
Input Leakage Current (SCL, TXD_, RSEL, IN1, TXF_)	I _{LI}				1	µA
Digital Power-On Reset	POD		1.0		2.2	V
Analog Power-On Reset	POA		2.0		2.75	V

DS1876

SFP Controller with Dual LDD Interface

MOD_, APC_ ELECTRICAL CHARACTERISTICS

(V_{CC} = +2.85V to +3.9V, T_A = -40°C to +95°C, unless otherwise noted.)

PARAMETER	SYMBOL	CONDITIONS	MIN	TYP	MAX	UNITS
Main Oscillator Frequency	f _{OSC}			5		MHz
Delta-Sigma Input-Clock Frequency	f _{DS}			f _{OSC} /2		MHz
Reference Voltage Input (REFIN)	V _{REFIN}	Minimum 0.1μF to GND	2		V _{CC}	V
Output Range			0		V _{REFIN}	V
Output Resolution		See the <i>Delta-Sigma Outputs</i> section for details			10	Bits
Output Impedance	R _{DS}			35	100	Ω

ANALOG QUICK-TRIP CHARACTERISTICS

(V_{CC} = +2.85V to +3.9V, T_A = -40°C to +95°C, unless otherwise noted.)

PARAMETER	SYMBOL	CONDITIONS	MIN	TYP	MAX	UNITS
TXP HI, TXP LO Full-Scale Voltage				2.507		V
HBIAS Full-Scale Voltage				1.25		V
PMON_ Input Resistance			35	50	65	kΩ
Resolution				8		Bits
Error		T _A = +25°C		±2		%FS
Integral Nonlinearity			-1		+1	LSB
Differential Nonlinearity			-1		+1	LSB
Temperature Drift			-2.5		+2.5	%FS
Offset			-5		+10	mV

ANALOG VOLTAGE MONITORING CHARACTERISTICS

(V_{CC} = +2.85V to +3.9V, T_A = -40°C to +95°C, unless otherwise noted.)

PARAMETER	SYMBOL	CONDITIONS	MIN	TYP	MAX	UNITS
ADC Resolution				13		Bits
Input/Supply Accuracy (BMON_, PMON_, V _{CC})	ACC	At factory setting		0.25	0.5	%FS
Update Rate for Temperature, BMON_, PMON_, V _{CC}	t _{RR}			64	78	ms
Input/Supply Offset (BMON_, PMON_, V _{CC})	V _{OS}	(Note 3)		0	5	LSB
Factory Setting (Note 4)		BMON_, PMON_		2.5		V
		V _{CC}		6.5536		

SFP Controller with Dual LDD Interface

DIGITAL THERMOMETER CHARACTERISTICS

(V_{CC} = +2.85V to +3.9V, T_A = -40°C to +95°C, unless otherwise noted.)

PARAMETER	SYMBOL	CONDITIONS	MIN	TYP	MAX	UNITS
Thermometer Error	TERR	-40°C to +95°C	-3		+3	°C

AC ELECTRICAL CHARACTERISTICS

(V_{CC} = +2.85V to +3.9V, T_A = -40°C to +95°C, unless otherwise noted.)

PARAMETER	SYMBOL	CONDITIONS	MIN	TYP	MAX	UNITS
TXD_ Enable	t _{OFF}	From TXD_			5	µs
Recovery from TXD_ Disable (Figure 2)	t _{ON}	From TXD_			1	ms
Fault Reset Time (to TXFOUT = 0)	t _{INTR1}	From TXD_		131		ms
	t _{INTR2}	On power-up or TXD_, when VCC LO alarm is detected (Note 5)		161		
Fault Assert Time (to TXFOUT = 1)	t _{FAULT}	After HTXP_, LTXP_, HBATH_	1.6		10.5	µs

QUICK-TRIP TIMING CHARACTERISTICS

(V_{CC} = +2.85V to +3.9V, T_A = -40°C to +95°C, unless otherwise noted.)

PARAMETER	SYMBOL	CONDITIONS	MIN	TYP	MAX	UNITS
Output-Enable Time Following POA	t _{INIT}			20		ms
Sample Time per Quick-Trip Comparison	t _{REP}			1.6		µs

I²C AC ELECTRICAL CHARACTERISTICS

(V_{CC} = +2.85V to +3.9V, T_A = -40°C to +95°C, timing referenced to V_{IL}(MAX) and V_{IH}(MIN), unless otherwise noted. See the I²C Communication section.)

PARAMETER	SYMBOL	CONDITIONS	MIN	TYP	MAX	UNITS
SCL Clock Frequency	f _{SCL}	(Note 6)	0		400	kHz
Clock Pulse-Width Low	t _{LOW}		1.3			µs
Clock Pulse-Width High	t _{HIGH}		0.6			µs
Bus Free Time Between STOP and START Condition	t _{BUF}		1.3			µs
START Hold Time	t _{HD:STA}		0.6			µs
START Setup Time	t _{SU:STA}		0.6			µs
Data Out Hold Time	t _{HD:DAT}		0		0.9	µs
Data In Setup Time	t _{SU:DAT}		100			ns
Rise Time of Both SDA and SCL Signals	t _R	(Note 7)	20 + 0.1C _B		300	ns
Fall Time of Both SDA and SCL Signals	t _F	(Note 7)	20 + 0.1C _B		300	ns
STOP Setup Time	t _{SU:STO}		0.6			µs
Capacitive Load for Each Bus Line	C _B				400	pF
EEPROM Write Time	t _{WR}	(Note 8)			20	ms

DS1876

SFP Controller with Dual LDD Interface

NONVOLATILE MEMORY CHARACTERISTICS

(VCC = +2.85V to +3.9V, unless otherwise noted.)

PARAMETER	SYMBOL	CONDITIONS	MIN	TYP	MAX	UNITS
EEPROM Write Cycles		At +25°C	200,000			
		At +85°C	50,000			

Note 1: All voltages are referenced to ground. Current into the IC is positive, and current out of the IC is negative.

Note 2: Inputs are at supply rail. Outputs are not loaded.

Note 3: This parameter is guaranteed by design.

Note 4: Full scale is user programmable.

Note 5: A temperature conversion is completed and MOD1 DAC, MOD2 DAC, APC1 DAC, and APC2 DAC values are recalled from the LUT and VCC has been measured to be above VCC LO alarm, if the VCC LO alarm is enabled.

Note 6: I²C interface timing shown is for fast-mode (400kHz) operation. This device is also backward compatible with I²C standard mode.

Note 7: C_B—Total capacitance of one bus line in pF.

Note 8: EEPROM write begins after a STOP condition occurs.

SFP Controller with Dual LDD Interface

Typical Operating Characteristics

($V_{CC} = 3.3V$, $T_A = +25^\circ C$, unless otherwise noted.)

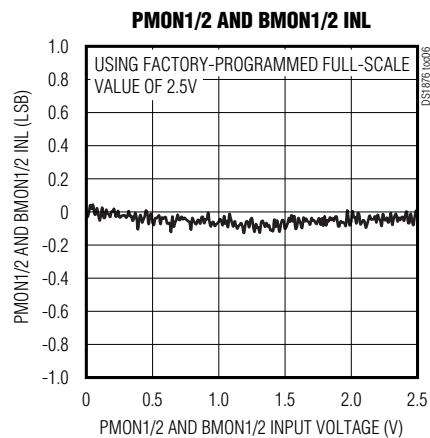
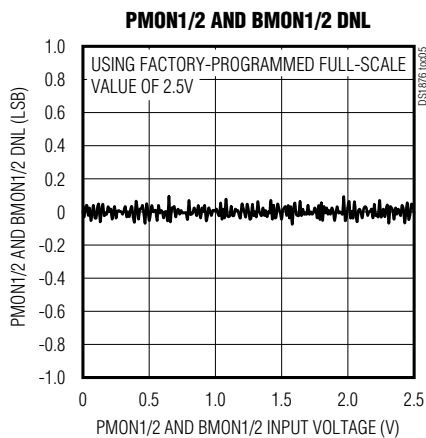
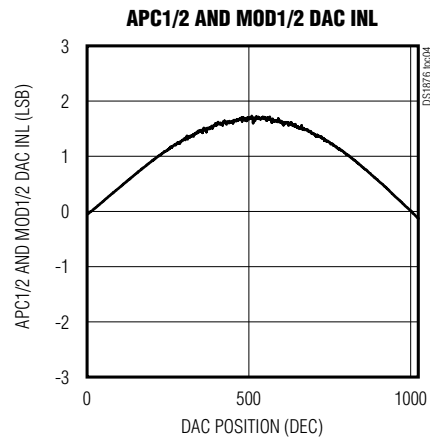
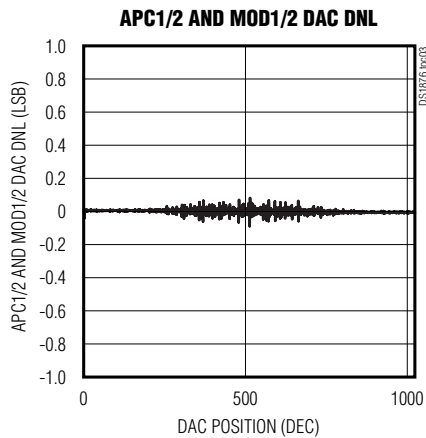
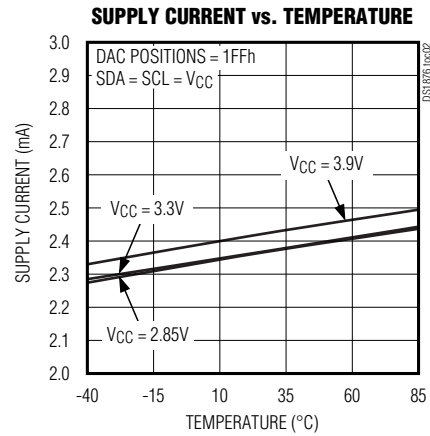
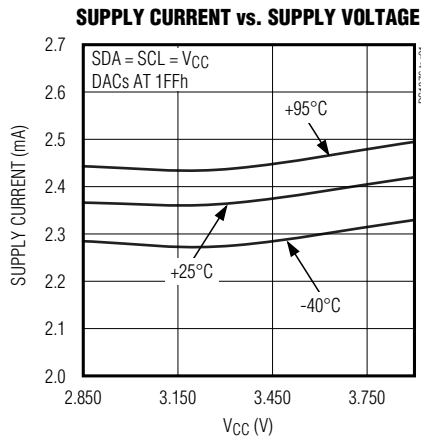

DS1876

SFP Controller with Dual LDD Interface

Pin Configuration

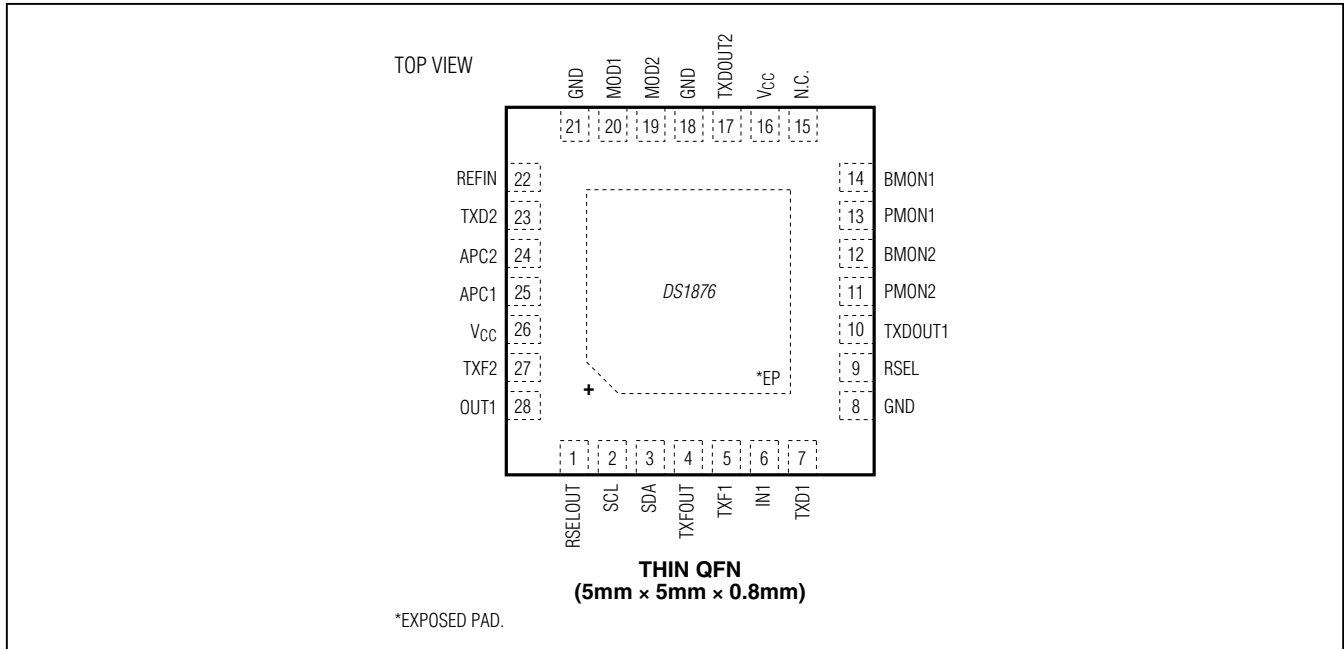

Pin Description

PIN	NAME	FUNCTION
1	RSELOUT	Rate-Select Output
2	SCL	I ² C Serial-Clock Input
3	SDA	I ² C Serial-Data Input/Output
4	TXFOUT	Transmit Fault Output, Open Drain
5	TXF1	Transmit Fault Input 1
6	IN1	Digital Input. General-purpose input, AS1 in SFF-8079, or RS1 in SFF-8431.
7	TXD1	Transmit Disable Input 1
8, 18, 21	GND	Ground Connection
9	RSEL	Rate-Select Input
10	TXDOUT1	Transmit Disable Output 1
11	PMON2	External Monitor Input PMON2 and HTXP2/LTXP2 Quick Trip
12	BMON2	External Monitor Input BMON2 and HBATH2 Quick Trip
13	PMON1	External Monitor Input PMON1 and HTXP1/LTXP1 Quick Trip

PIN	NAME	FUNCTION
14	BMON1	External Monitor Input BMON1 and HBATH1 Quick Trip
15	N.C.	No Connection
16, 26	VCC	Power-Supply Input
17	TXDOUT2	Transmit Disable Output 2
19	MOD2	MOD2 DAC, Delta-Sigma Output
20	MOD1	MOD1 DAC, Delta-Sigma Output
22	REFIN	Reference Input for DAC1 and DAC2
23	TXD2	Transmit Disable Input 2
24	APC2	APC2 DAC, Delta-Sigma Output
25	APC1	APC1 DAC, Delta-Sigma Output
27	TXF2	Transmit Fault Input 2
28	OUT1	Digital Output. General-purpose output, AS1 output in SFF-8079, or RS1 output in SFF-8431.
—	EP	Exposed Pad (Connect to GND)

DS1876

SFP Controller with Dual LDD Interface

Block Diagram

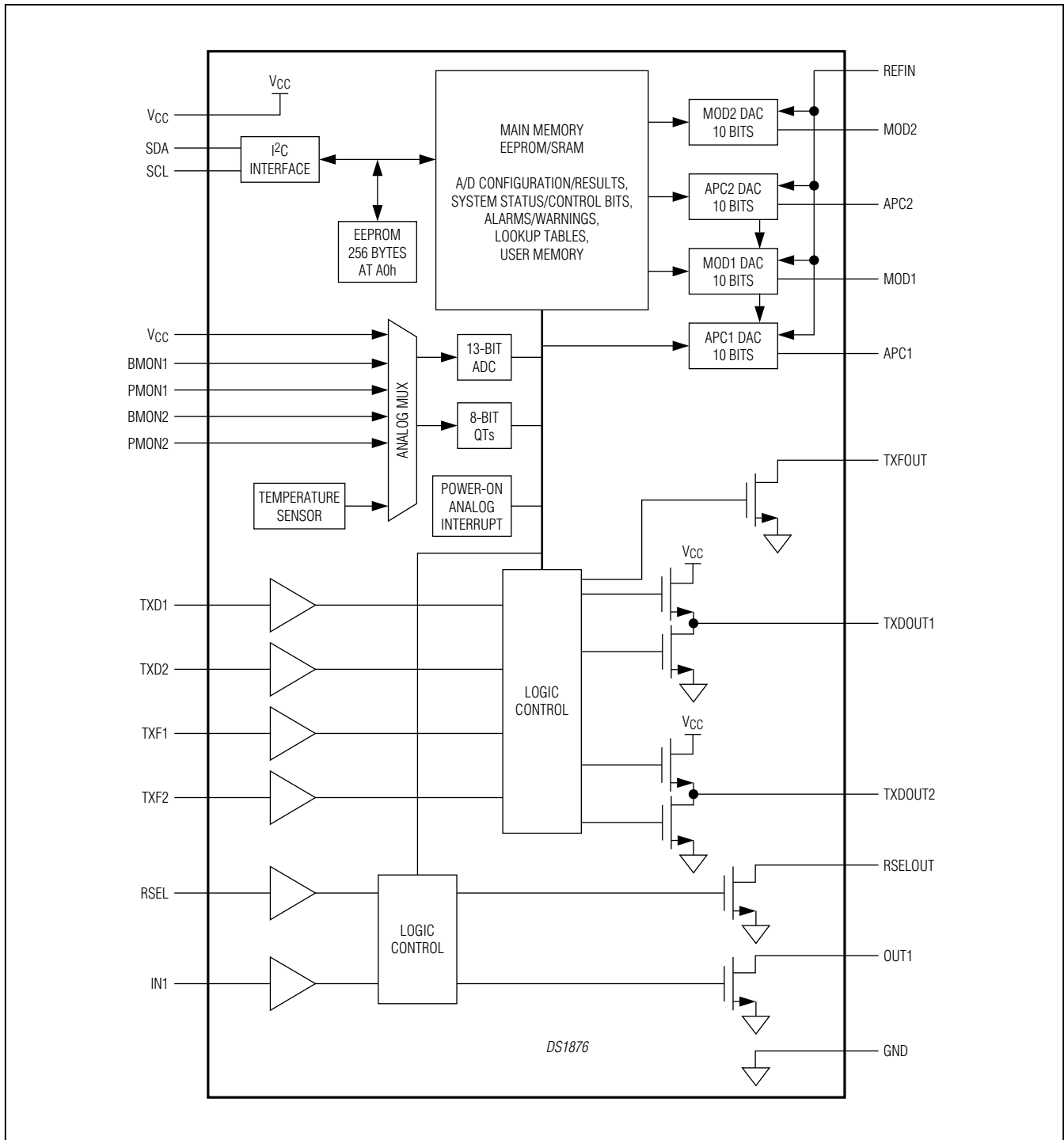

DS1876

SFP Controller with Dual LDD Interface

Typical Operating Circuit

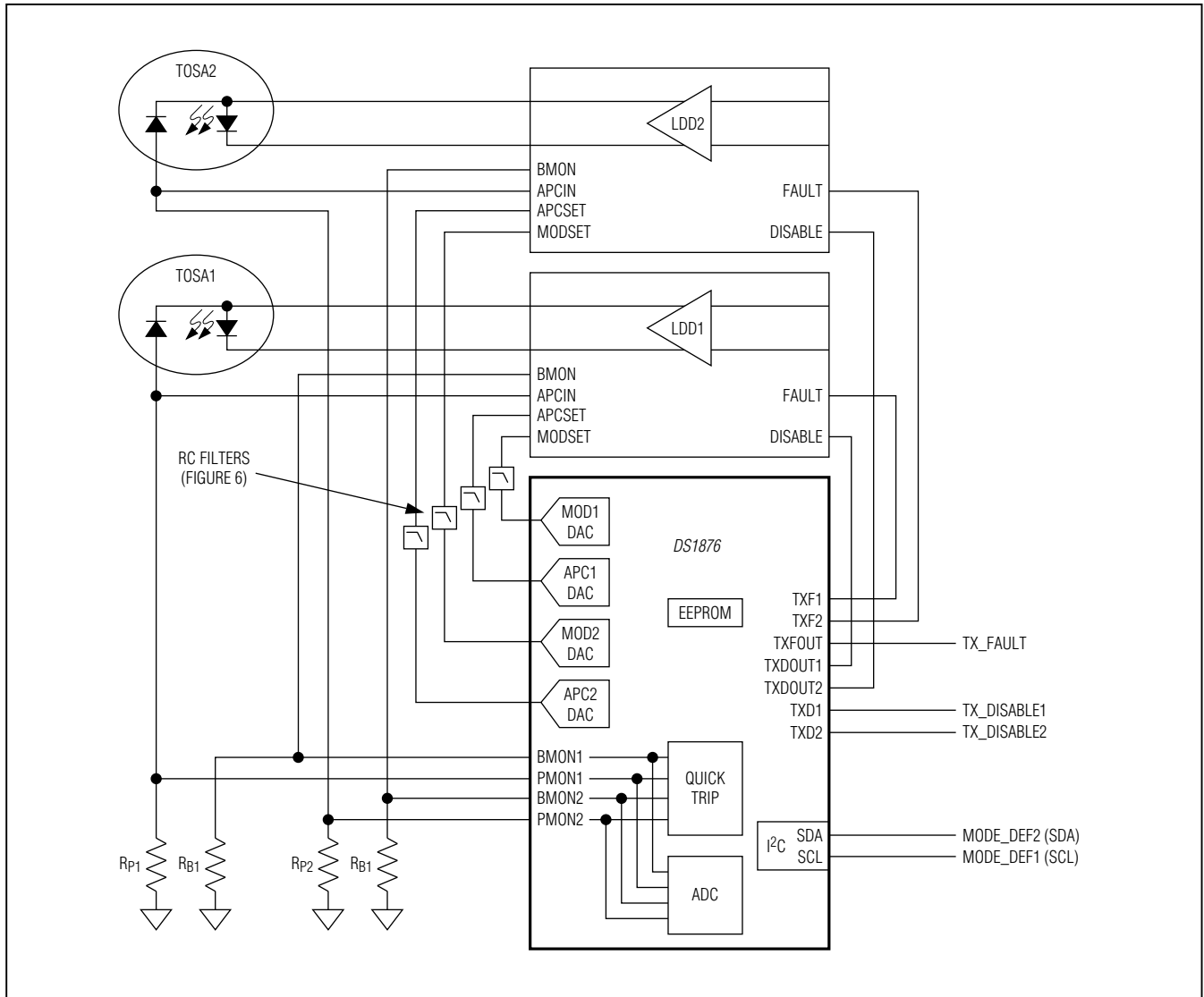

Detailed Description

The DS1876 integrates the control and monitoring functionality required in a dual transmitter system. Key components of the DS1876 are shown in the *Block Diagram* and described in subsequent sections.

DACs During Power-Up

On power-up, the DS1876 sets the DACs to high impedance. After time t_{INIT} , the DACs are set to an initial condition

set in EEPROM. After a temperature conversion is completed and if the VCC LO alarm is enabled, an additional VCC conversion above the customer-defined VCC LO alarm level is required before the DACs are updated with the value determined by the temperature conversion and the DAC LUT.

If a fault is detected, and TXD1 and TXD2 are toggled to re-enable the outputs, the DS1876 powers up following a similar sequence to an initial power-up. The

SFP Controller with Dual LDD Interface

Table 1. Acronyms

ACRONYM	DESCRIPTION
ADC	Analog-to-Digital Converter
AGC	Automatic Gain Control
APC	Automatic Power Control
APD	Avalanche Photodiode
ATB	Alarm Trap Bytes
DAC	Digital-to-Analog Converter
LOS	Loss of Signal
LUT	Lookup Table
NV	Nonvolatile
QT	Quick Trip
TE	Tracking Error
TIA	Transimpedance Amplifier
ROSA	Receiver Optical Subassembly
SEE	Shadowed EEPROM
SFF	Small Form Factor
SFF-8472	Document Defining Register Map of SFPs and SFFs
SFP	Small Form Factor Pluggable
SFP+	Enhanced SFP
TOSA	Transmit Optical Subassembly
TXP	Transmit Power

only difference is that the DS1876 already has determined the present temperature, so the t_{INIT} time is not required for the DS1876 to recall the APC and MOD set points from EEPROM. See Figure 1.

DACs as a Function of Transmit Disable (TXD1, TXD2)

If TXD1 or TXD2 are asserted (logic 1) during normal operation, the associated outputs are disabled within t_{OFF} . When TXD1 or TXD2 are deasserted (logic 0), the DS1876 sets the DACs with the value associated with the present temperature. When asserted, soft TXD1 or soft TXD2 (TXDC) (Lower Memory, Register 6Eh) would allow a software control identical to the TXD1 or TXD2 pin (Figure 2). The POLARITY register (Table 02h, Register C6h) determines if the off-state value of the DACs is V_{REFIN} or 0V.

Quick-Trip Timing

As shown in Figure 3, the DS1876's input comparator is shared among the six quick-trip alarms (TXP1 HI, TXP1 LO, TXP2 HI, TXP2 LO, BIAS1 HI, and BIAS2 HI). The comparator polls the alarms in a multiplexed sequence. The updates are used to compare the HXP1, LXP1, HXP2, and LXP2 (monitor diode voltages) and the HBATH1 and HBATH2 (BMON1, BMON2) signals against the internal APC and BIAS reference, respectively. Depending on the results of the comparison, the

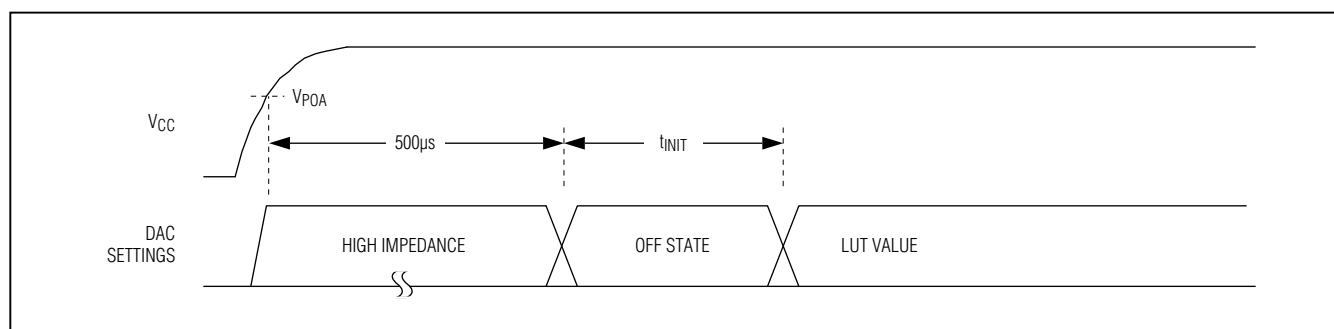

Figure 1. Power-Up Timing

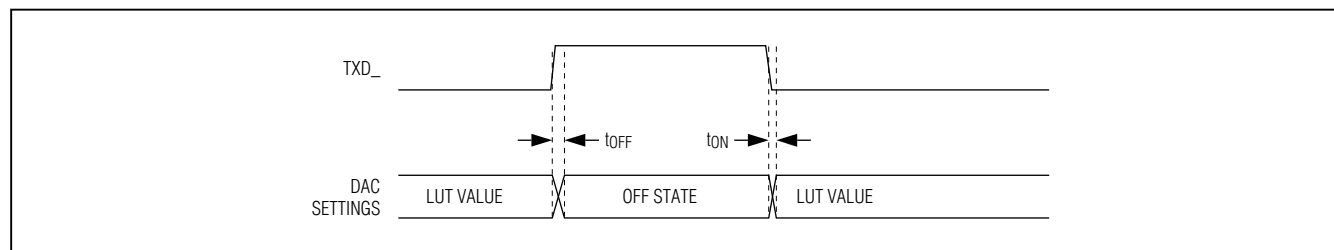

Figure 2. TXD1, TXD2 Timing

DS1876

SFP Controller with Dual LDD Interface

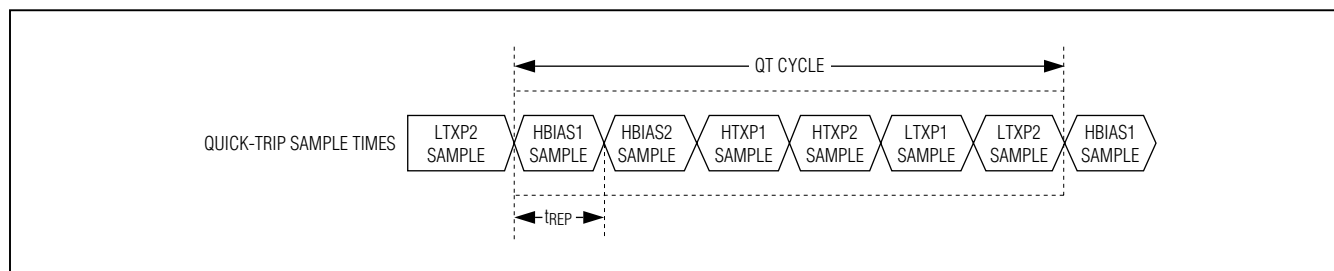

Figure 3. Quick-Trip Sample Timing

Table 2. ADC Default Monitor Full-Scale Ranges

SIGNAL (UNITS)	+FS SIGNAL	+FS HEX	-FS SIGNAL	-FS HEX
Temperature (°C)	127.996	7FFF	-128	8000
V _{CC} (V)	6.5528	FFF8	0	0000
PMON1, PMON2 and BMON1, BMON2 (V)	2.4997	FFF8	0	0000

corresponding alarms and warnings (TXP HI1, TXP LO1, TXP HI2, TXP LO2, BIAS HI1, and BIAS HI2) are asserted or deasserted.

After resetting, the device completes one QT cycle before making comparisons. The TXP LO quick-trip alarm updates its alarm bit, but does not create FETG until after TXDEXT. TXP HI and BIAS HI can also be configured to wait for TXDEXT; however, this can be disabled using QTNEXT_ (Table 02h, Register 88h).

Monitors and Fault Detection

Monitors

Monitoring functions on the DS1876 include six quick-trip comparators and six ADC channels. This monitoring combined with the alarm enables (Table 01h/05h) determines when/if the DS1876 turns off DACs and triggers the TXFOUT and TXDOUT1, TXDOUT2 outputs. All the monitoring levels and interrupt masks are user programmable.

Six Quick-Trip Monitors and Alarms

Six quick-trip monitors are provided to detect potential laser safety issues and LOS status. These monitor the following:

- 1) High Bias Current 1 (HBATH1), causing QT BIAS1 HI
- 2) Low Transmit Power 1 (LTXP1), causing QT TXP1 LO
- 3) High Transmit Power 1 (HTXP1), causing QT TXP1 HI
- 4) High Bias Current 2 (HBATH2), causing QT BIAS2 HI
- 5) Low Transmit Power 2 (LTXP2), causing QT TXP2 LO
- 6) High Transmit Power 2 (HTXP2), causing QT TXP2 HI

The high and low transmit power quick-trip registers (HTXP1, HTXP2, LTXP1, and LTXP2) set the thresholds used to compare against the PMON1 and PMON2 voltages to determine if the transmit power is within specification. The HBATH1 and HBATH2 QTs compare the BMON1 and BMON2 inputs (generally from the laser driver's bias monitor output) against their threshold settings to determine if the present bias current is above specification. The bias and power QTs are routed to FETG through interrupt masks to allow combinations of these alarms to be used to trigger FETG. The bias and power QTs are directly connected to TXFOUT (see Figure 9). The user can program up to eight different temperature-indexed threshold levels for HBATH1 and HBATH2 (Table 06h, Registers E0h–E7h).

Six ADC Monitors and Alarms

The ADC monitors six channels that measure temperature (internal temp sensor), V_{CC}, PMON1, PMON2, BMON1, and BMON2 using an analog multiplexer to measure them round-robin with a single ADC (see the *ADC Timing* section). The channels have a customer-programmable full-scale range, and all channels have a customer-programmable offset value that is factory programmed to a default value (see Table 2). Additionally, PMON1, PMON2 and BMON1, BMON2 can right-shift results by up to 7 bits before the results are compared to alarm thresholds or read over the I²C bus. This allows customers with specified ADC ranges to calibrate the ADC full scale to a factor of 1/2ⁿ of their specified range to measure small signals. The DS1876 can then right-shift the results by n bits to maintain the bit weight of their specification.

SFP Controller with Dual LDD Interface

The ADC results (after right-shifting, if used) are compared to the alarm and warning thresholds after each conversion, and the corresponding alarms are set that can be used to trigger the TXFOUT output. These ADC thresholds are user programmable, as are the masking registers that can be used to prevent the alarms from triggering the TXFOUT output.

ADC Timing

There are six analog channels that are digitized in a round-robin fashion in the order as shown in Figure 4. The total time required to convert all six channels is t_{RR} (see the *Analog Voltage Monitoring Characteristics* table for details).

Right-Shifting ADC Result

If the weighting of the ADC digital reading must conform to a predetermined full-scale (PFS) value defined by a standard's specification (e.g., SFF-8472), then right-shifting can be used to adjust the PFS analog measurement range while maintaining the weighting of the ADC results. The DS1876's range is wide enough to cover all requirements; when the maximum input value is $\leq 1/2$ the FS value, right-shifting can be used to obtain greater accuracy. For instance, the maximum voltage might be $1/8$ the specified PFS value, so only $1/8$ of the converter's range is effective over this range. An alternative is to calibrate the ADC's full-scale range to $1/8$ the readable PFS value and use a right-shift value of 3. With this implementation, the resolution of the measurement is increased by a factor of 8, and because the result is digitally divided by 8 by right-shifting, the bit weight of the measurement still meets the standard's specification (i.e., SFF-8472).

The right-shift operation on the ADC result is carried out based on the contents of right-shift control registers (Table 02h, Registers 8Eh–8Fh) in EEPROM. Four analog channels—PMON1, PMON2, BMON1, and BMON2—each have 3 bits allocated to set the number of right-

shifts. Up to seven right-shift operations are allowed and are executed as a part of every conversion before the results are compared to the high and low alarm levels, or loaded into their corresponding measurement registers (Lower Memory, Registers 64h–6Bh). This is true during the setup of internal calibration as well as during subsequent data conversions.

Low-Voltage Operation

The DS1876 contains two power-on reset (POR) levels. The lower level is a digital POR (POD) and the higher level is an analog POR (POA). At startup, before the supply voltage rises above POA, the outputs are disabled, all SRAM locations are set to their defaults, shadowed EEPROM (SEE) locations are zero, and all analog circuitry is disabled. When VCC reaches POA, the SEE is recalled, and the analog circuitry is enabled. While VCC remains above POA, the device is in its normal operating state, and it responds based on its nonvolatile configuration. If during operation VCC falls below POA, but is still above POD, the SRAM retains the SEE settings from the first SEE recall, but the device analog is shut down and the outputs disabled. If the supply voltage recovers back above POA, the device immediately resumes normal operation. If the supply voltage falls below POD, the device SRAM is placed in its default state and another SEE recall is required to reload the nonvolatile settings. The EEPROM recall occurs the next time VCC next exceeds POA. Figure 5 shows the sequence of events as the voltage varies.

Any time VCC is above POD, the I²C interface can be used to determine if VCC is below the POA level. This is accomplished by checking the RDYB bit in the status byte (Lower Memory, Register 6Eh). RDYB is set when VCC is below POA; when VCC rises above POA, RDYB is timed (within 500 μ s) to go to 0, at which point the part is fully functional.

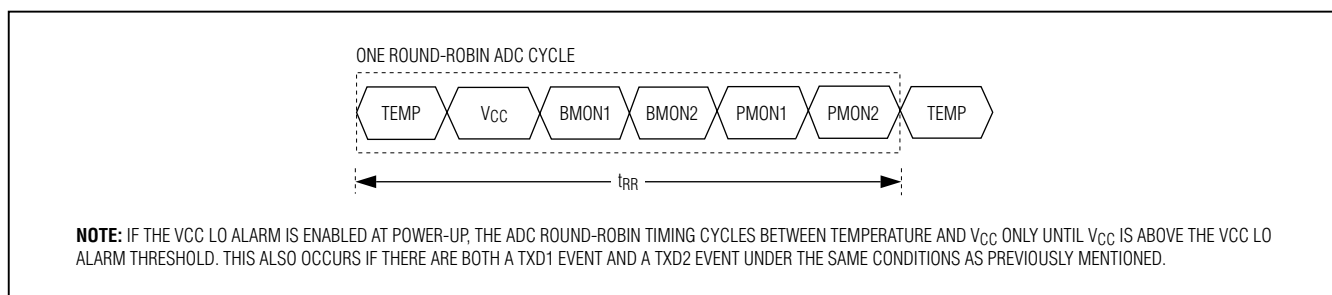

Figure 4. ADC Round-Robin Timing

DS1876

SFP Controller with Dual LDD Interface

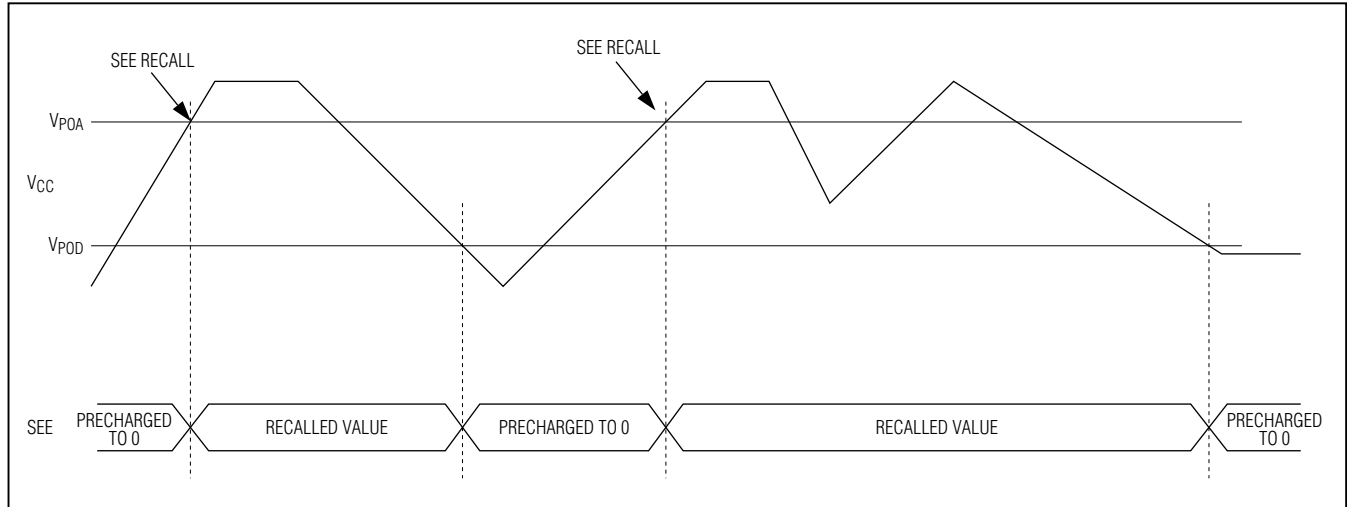

Figure 5. Low-Voltage Hysteresis Example

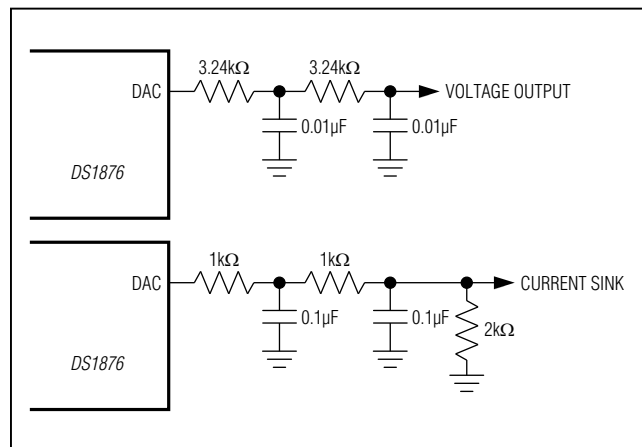

Figure 6. Recommended RC Filter for DAC Outputs in Voltage Mode and Current Sink Mode

For all device addresses sourced from EEPROM (Table 02h, Register 8Bh), the default device addresses are A2h and B2h until VCC exceeds POA allowing the device address to be recalled from the EEPROM.

Delta-Sigma Outputs

Four delta-sigma outputs are provided: MOD1, MOD2, APC1, and APC2. With the addition of an external RC filter, these outputs provide 10-bit resolution analog outputs with the full-scale range set by the input REFIN. Each output is either manually controlled or controlled using a temperature-indexed LUT.

A delta-sigma DAC has a digital output using pulse-density modulation. It provides much lower output ripple than a standard digital PWM output given the same clock rate and filter components. Before t_{INIT} , the DAC outputs are high impedance. The external RC filter components are chosen based on ripple requirements, output load, delta-sigma frequency, and desired response time. Figure 6 shows a recommended filter.

For illustrative purposes, a 3-bit example is provided in Figure 7.

In LUT mode the DACs are each controlled by an LUT with high-temperature resolution and an OFFSET LUT with lower temperature resolution. The high-resolution LUTs each have 2°C resolutions. The OFFSET LUTs are located in the upper eight registers (F8h–FFh) of the table containing each high-resolution LUT. The DAC values are determined as follows:

$$\text{DAC value} = \text{LUT} + 4 \times (\text{OFFSET LUT})$$

An example calculation for MOD1 DAC is as follows:

Assumptions:

- 1) Temperature is +43°C
- 2) Table 04h (MOD1 OFFSET LUT), Register FCh = 2Ah
- 3) Table 04h (MOD1 LUT), Register AAh = 7Bh

Because the temperature is +43°C, the MOD1 LUT index is AAh and the MOD1 OFFSET LUT index is FCh.

$$\text{MOD1 DAC} = 7Bh + 4 \times 2Ah = 123h = 291$$

SFP Controller with Dual LDD Interface

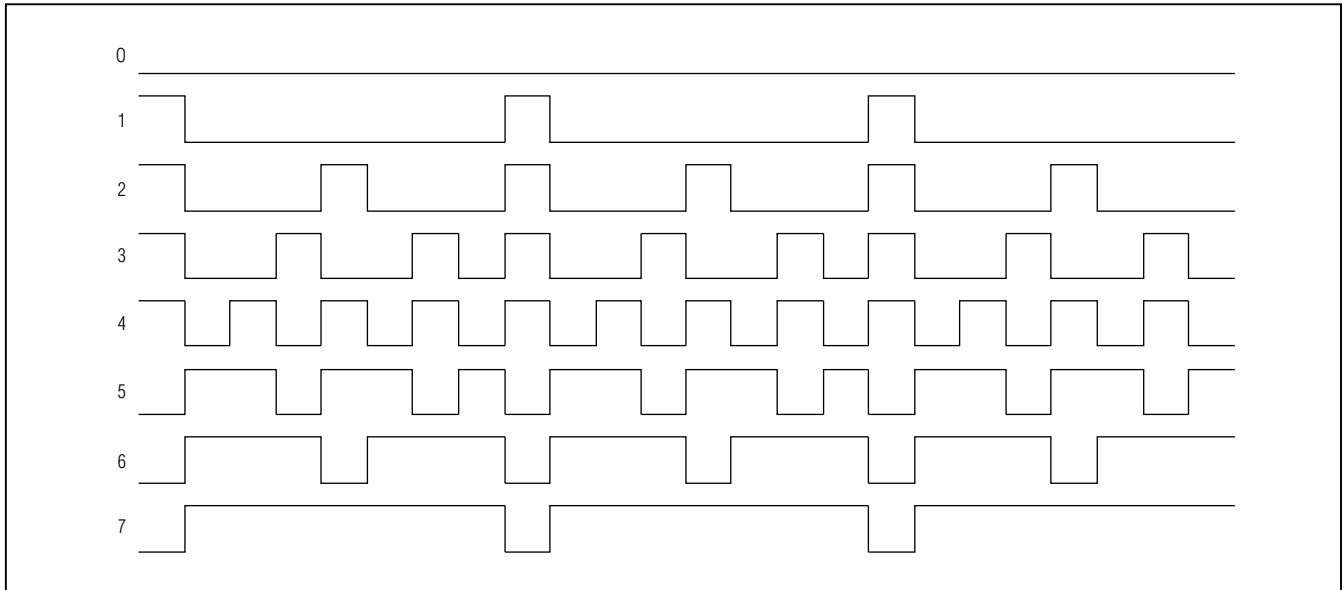

Figure 7. 3-Bit (8-Position) Delta-Sigma Example

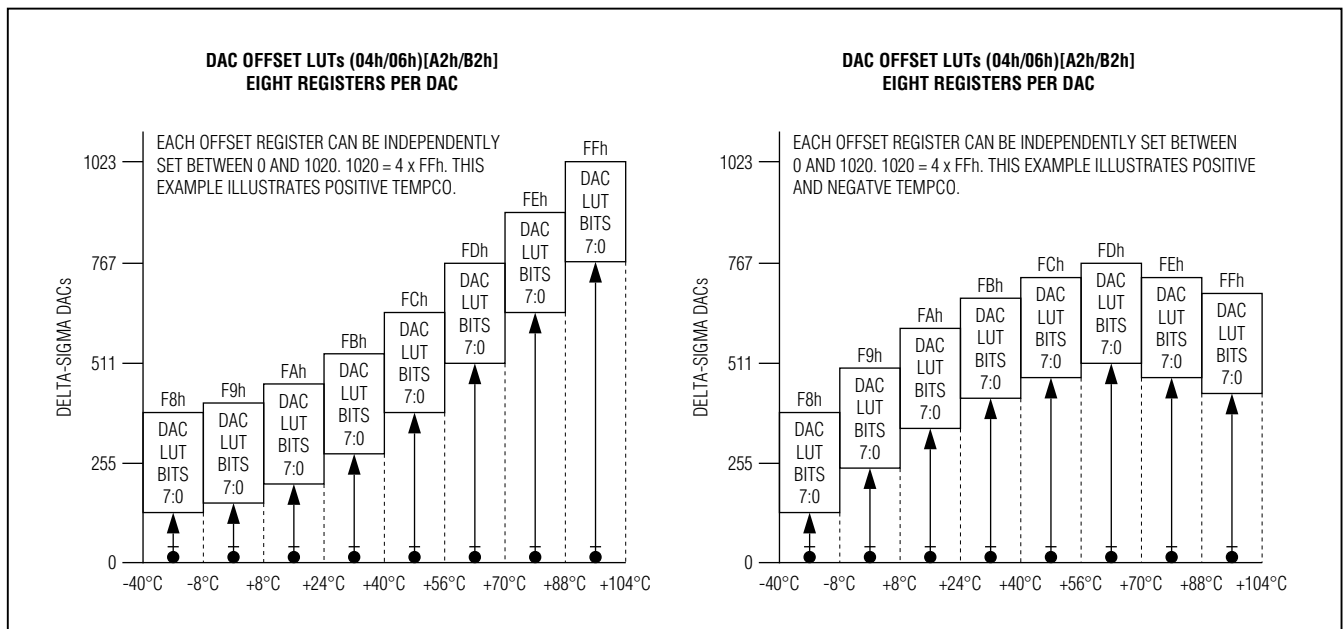

Figure 8. DAC OFFSET LUTs

When temperature controlled, the DACs are updated after each temperature conversion.

The reference input, REFIN, is the supply voltage for the output buffer of all four DACs. The voltage connected to

REFIN and its decoupling must be able to support the edge rate requirements of the delta-sigma outputs. In a typical application, a 0.1µF capacitor should be connected between REFIN and ground.

DS1876

SFP Controller with Dual LDD Interface

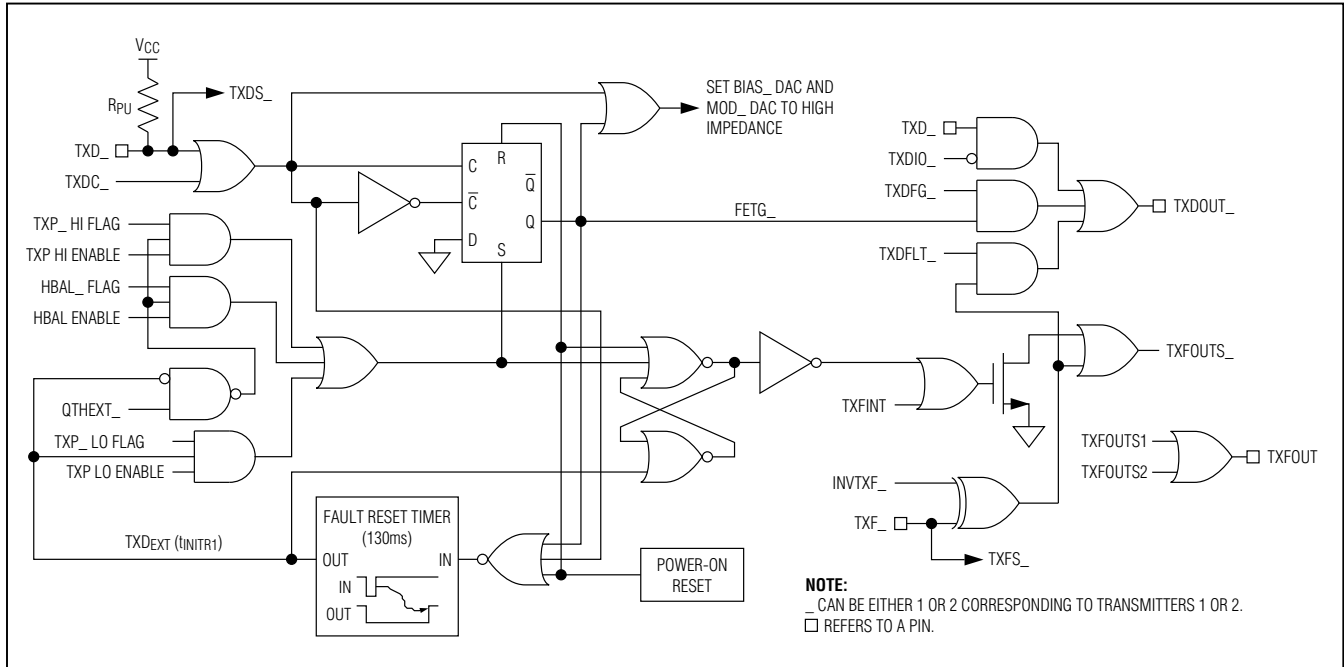

Figure 9. Logic Diagram 1

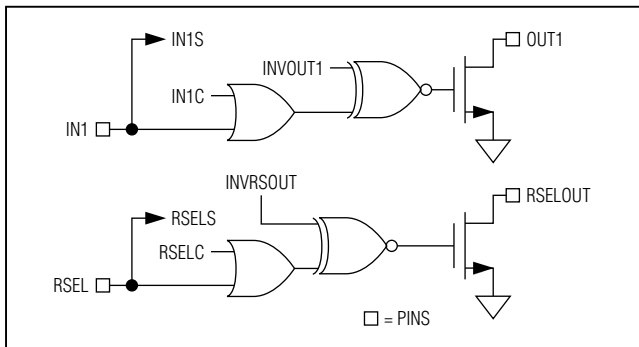

Figure 10. Logic Diagram 2

Digital I/O Pins

Six digital input pins and five digital output pins are provided for monitoring and control.

IN1, RSEL, OUT1, RSELOUT

Digital input pins IN1 and RSEL primarily serve to meet the rate-select requirements of SFP and SFP+. They can also serve as general-purpose inputs. OUT1 and RSELOUT are driven by a combination of the IN1, RSEL, and logic dictated by control registers in the EEPROM (see Figure 10). The levels of IN1 and RSEL can be read from the STATUS register (Lower Memory, Register 6Eh). The open-drain output OUT1 can be controlled and/or inverted using the CNFGB register (Table 02h,

Register 89h). The open-drain RSELOUT output is software controlled and/or inverted through the STATUS register and CNFGA register (Table 02h, Register 88h). External pullup resistors must be provided on OUT1 and RSELOUT to realize high logic levels.

TXF1, TXF2, TXFOUT, TXD1, TXD2, TXDOUT1, TXDOUT2

TXDOUT1 and TXDOUT2 are generated from a combination of TXF1, TXF2, TXD1, TXD2, and the internal signals FETG1 and FETG2 (Table 02h, Register 8Ah). A software control identical to TXD1 and TXD2 is also available (TXDC1 and TXDC2, Lower Memory, Register 6Eh). A TXD1 or TXD2 pulse is internally extended (TXDEXT) by time tINTR1 to inhibit the latching of low alarms and warnings related to the APC loop to allow for the loop to stabilize. The nonlatching alarms and warnings are TXP LO, BMON1 LO, BMON2 LO, PMON1 LO, and PMON2 LO. In addition, TXP LO is disabled from creating FETG. See the *Transmit Fault (TXFOUT) Output* section for a detailed explanation of TXFOUT. As shown in Figure 9, the same signals and faults can also be used to generate the internal signal FETG. FETG is used to send a fast “turn-off” command to the laser driver. The intended use is a direct connection to the laser driver’s TXD1, TXD2 input if this is desired. When VCC < POA, TXDOUT1 and TXDOUT2 are high impedance.

SFP Controller with Dual LDD Interface

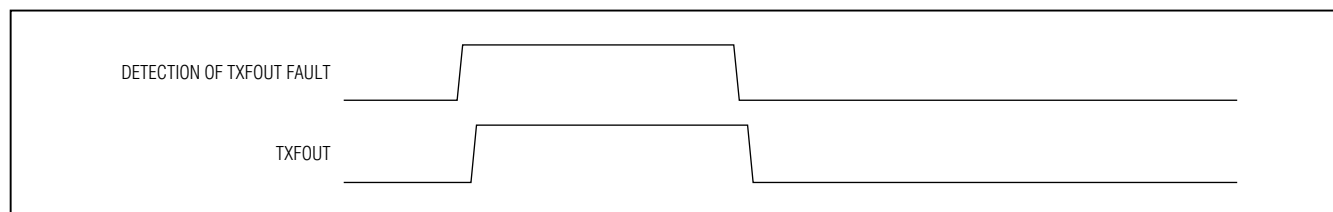

Figure 11a. TXFOUT Nonlatched Operation

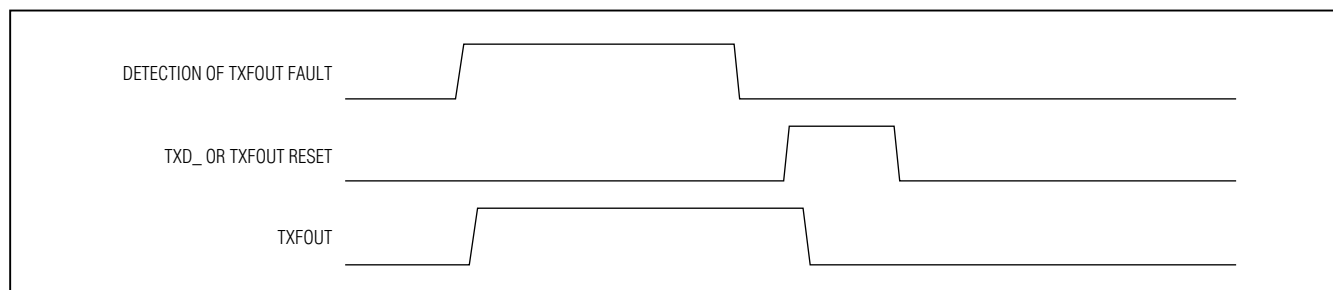

Figure 11b. TXFOUT Latched Operation

Transmit Fault (TXFOUT) Output

TXFOUT can be triggered by all alarms, warnings, QTs, TXD1, TXD2, TXF1, and TXF2 (see Figure 9). The six ADC alarms and warnings are controlled by enable bits (Table 01h/05h, Registers F8h and FCh). See Figures 11a and 11b for nonlatched and latched operation for TXFOUT. The CNFGB register (Table 02h, Register 89h) controls the latching of the alarms.

Die Identification

The DS1876 has an ID hardcoded in its memory. Two registers (Table 02h, Registers 86h–87h) are assigned for this feature. Register 86h reads 76h to identify the part as the DS1876; Register 87h reads the present device version.

I2C Communication

I2C Definitions

The following terminology is commonly used to describe I2C data transfers.

Master Device: The master device controls the slave devices on the bus. The master device generates SCL clock pulses and START and STOP conditions.

Slave Devices: Slave devices send and receive data at the master's request.

Bus Idle or Not Busy: Time between STOP and START conditions when both SDA and SCL are inactive and in their logic-high states.

START Condition: A START condition is generated by the master to initiate a new data transfer with a slave. Transitioning SDA from high to low while SCL remains high generates a START condition. See Figure 12 for applicable timing.

STOP Condition: A STOP condition is generated by the master to end a data transfer with a slave. Transitioning SDA from low to high while SCL remains high generates a STOP condition. See Figure 12 for applicable timing.

Repeated START Condition: The master can use a repeated START condition at the end of one data transfer to indicate that it will immediately initiate a new data transfer following the current one. Repeated STARTs are commonly used during read operations to identify a specific memory address to begin a data transfer. A repeated START condition is issued identically to a normal START condition. See Figure 12 for applicable timing.

Bit Write: Transitions of SDA must occur during the low state of SCL. The data on SDA must remain valid and unchanged during the entire high pulse of SCL plus the setup and hold time requirements (Figure 12). Data is shifted into the device during the rising edge of the SCL.

Bit Read: At the end of a write operation, the master must release the SDA bus line for the proper amount of setup time (Figure 12) before the next rising edge

DS1876

SFP Controller with Dual LDD Interface

of SCL during a bit read. The device shifts out each bit of data on SDA at the falling edge of the previous SCL pulse and the data bit is valid at the rising edge of the current SCL pulse. Remember that the master generates all SCL clock pulses, including when it is reading bits from the slave.

Acknowledgement (ACK and NACK): An acknowledgement (ACK) or not-acknowledge (NACK) is always the 9th bit transmitted during a byte transfer. The device receiving data (the master during a read or the slave during a write operation) performs an ACK by transmitting a zero during the 9th bit. A device performs a NACK by transmitting a one during the 9th bit. Timing (Figure 12) for the ACK and NACK is identical to all other bit writes. An ACK is the acknowledgment that the device is properly receiving data. A NACK is used to terminate a read sequence or as an indication that the device is not receiving data.

Byte Write: A byte write consists of 8 bits of information transferred from the master to the slave (most significant bit first) plus a 1-bit acknowledgement from the slave to the master. The 8 bits transmitted by the master are done according to the bit write definition and the acknowledgement is read using the bit read definition.

Byte Read: A byte read is an 8-bit information transfer from the slave to the master plus a 1-bit ACK or NACK from the master to the slave. The 8 bits of information that are transferred (most significant bit first) from the slave to the master are read by the master using the

bit read definition, and the master transmits an ACK using the bit write definition to receive additional data bytes. The master must NACK the last byte read to terminate communication so the slave returns control of SDA to the master.

Slave Address Byte: Each slave on the I²C bus responds to a slave address byte sent immediately following a START condition. The slave address byte contains the slave address in the most significant 7 bits and the R/W bit in the least significant bit.

The DS1876 responds to three slave addresses. The auxiliary memory always responds to a fixed I²C slave address, A0h. (If the main device's slave address is programmed to be A0h, access to the auxiliary memory is disabled.) The Lower Memory and Tables 00h–06h respond to I²C slave addresses whose lower 3 bits are configurable (A0h–AEh, B0h–BEh) using the DEVICE ADDRESS byte (Table 02h, Register 8Bh). The user also must set the ASEL bit (Table 02h, Register 88h) for this address to be active. By writing the correct slave address with R/W = 0, the master indicates it writes data to the slave. If R/W = 1, the master reads data from the slave. If an incorrect slave address is written, the DS1876 assumes the master is communicating with another I²C device and ignores the communications until the next START condition is sent.

Memory Address: During an I²C write operation to the DS1876, the master must transmit a memory address to identify the memory location where the slave is to store the data. The memory address is

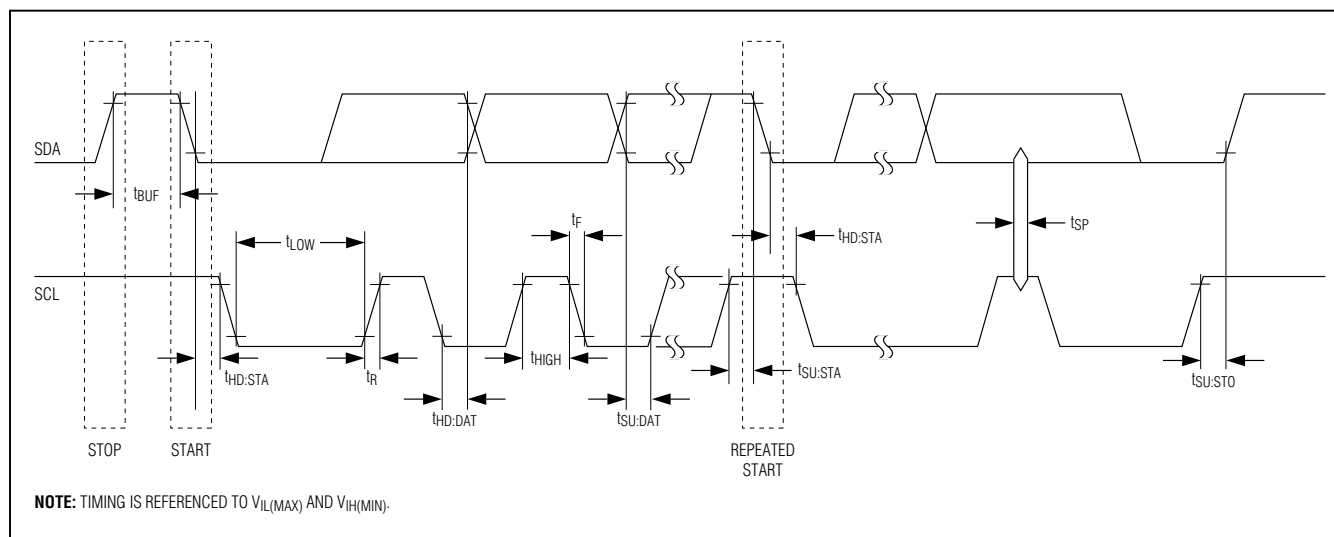

Figure 12. I²C Timing

SFP Controller with Dual LDD Interface

always the second byte transmitted during a write operation following the slave address byte.

I²C Protocol

See Figure 13 for an example of I²C timing.

Writing a Single Byte to a Slave: The master must generate a START condition, write the slave address byte ($R/\overline{W} = 0$), write the memory address, write the byte of data, and generate a STOP condition. Remember that the master must read the slave's acknowledgement during all byte write operations.

Writing Multiple Bytes to a Slave: To write multiple bytes to a slave, the master generates a START condition, writes the slave address byte ($R/\overline{W} = 0$), writes the memory address, writes up to 8 data bytes, and generates a STOP condition. The DS1876 writes 1 to 8 bytes (one page or row) with a single write transaction. This is internally controlled by an address counter that allows data to be written to consecutive addresses without transmitting a memory address before each data byte is sent. The address counter limits the write to one 8-byte page (one row of the memory map). Attempts to write to additional pages of memory without sending a STOP condition between pages result in the address counter wrapping around to the beginning of the present row.

For example: A 3-byte write starts at address 06h and writes three data bytes (11h, 22h, and 33h) to three "consecutive" addresses. The result is that addresses 06h and 07h would contain 11h and 22h, respectively, and the third data byte, 33h, would be written to address 00h.

To prevent address wrapping from occurring, the master must send a STOP condition at the end of the page, then wait for the bus-free or EEPROM write time to elapse. Then the master can generate a new START condition and write the slave address byte ($R/\overline{W} = 0$) and the first memory address of the next memory row before continuing to write data.

Acknowledge Polling: Any time a EEPROM page is written, the DS1876 requires the EEPROM write time (t_{WR}) after the STOP condition to write the contents of the page to EEPROM. During the EEPROM write time, the DS1876 does not acknowledge its slave address because it is busy. It is possible to take advantage of that phenomenon by repeatedly addressing the DS1876, which allows the next page to be written as soon as the DS1876 is ready to receive the data. The alternative to acknowledge polling is to wait for maximum period of t_{WR} to elapse before attempting to write again to the DS1876.

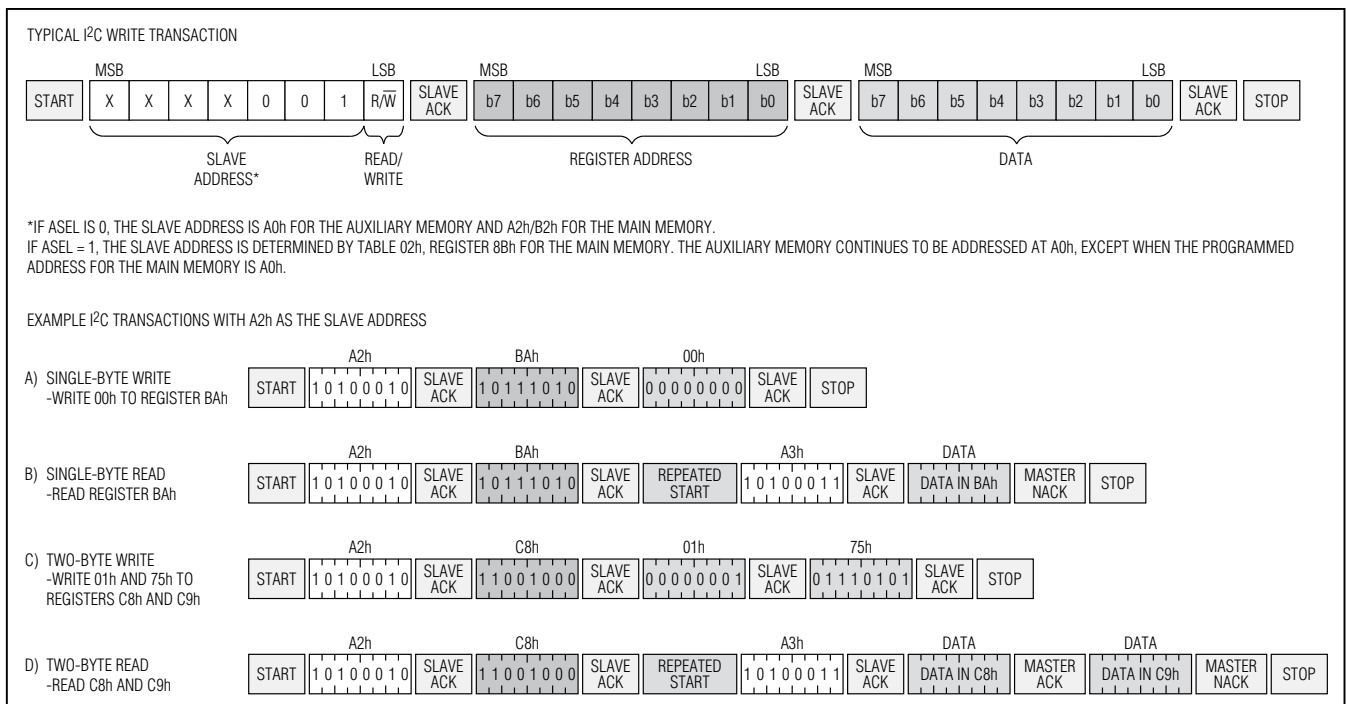

Figure 13. Example I²C Timing

DS1876

SFP Controller with Dual LDD Interface

EEPROM Write Cycles: When EEPROM writes occur, the DS1876 writes the whole EEPROM memory page, even if only a single byte on the page was modified. Writes that do not modify all 8 bytes on the page are allowed and do not corrupt the remaining bytes of memory on the same page. Because the whole page is written, bytes on the page that were not modified during the transaction are still subject to a write cycle. This can result in a whole page being worn out over time by writing a single byte repeatedly. Writing a page 1 byte at a time wears the EEPROM out 8x faster than writing the entire page at once. The DS1876's EEPROM write cycles are specified in the *Nonvolatile Memory Characteristics* table. The specification shown is at the worst-case temperature. It can handle approximately 10x that many writes at room temperature. Writing to SRAM-shadowed EEPROM memory with SEEB = 1 does not count as a EEPROM write cycle when evaluating the EEPROM's estimated lifetime.

Reading a Single Byte from a Slave: Unlike the write operation that uses the memory address byte to define where the data is to be written, the read operation occurs at the present value of the memory address counter. To read a single byte from the slave, the master generates a START condition, writes the slave address byte with $R/\overline{W} = 1$, reads the data byte with a NACK to indicate the end of the transfer, and generates a STOP condition.

Manipulating the Address Counter for Reads: A dummy write cycle can be used to force the address pointer to a particular value. To do this, the master generates a START condition, writes the slave address byte ($R/\overline{W} = 0$), writes the memory address where it desires to read, generates a repeated START condition, writes the slave address byte ($R/\overline{W} = 1$), reads data with ACK or NACK as applicable, and generates a STOP condition.

Memory Organization

The DS1876 features nine separate memory tables that are internally organized into 8-byte rows. The main device located at A2h is used for overall device configuration and transmitter 1 control, calibration, alarms, warnings, and monitoring.

Lower Memory, A2h is addressed from 00h–7Fh and contains alarm and warning thresholds, flags, masks, several control registers, password entry area (PWE), and the table-select byte.

Table 01h, A2h primarily contains user EEPROM (with PW1 level access) as well as alarm and warning enable bytes.

Table 02h, A2h/B2h is a multifunction space that contains configuration registers, scaling and offset values, passwords, and interrupt registers as well as other miscellaneous control bytes. All functions and status can be written and read from either A2h or B2h addresses.

Table 04h, A2h contains a temperature-indexed LUT for control of the MOD1 voltage. The MOD1 LUT can be programmed in 2°C increments over the -40°C to +102°C range. This also contains a temperature-indexed LUT for the MOD1 offsets.

Table 05h, A2h is empty by default. It can be configured to contain the alarm and warning enable bytes from Table 01h, Registers F8h–FFh with the MASK bit enabled (Table 02h, Register 88h). In this case Table 01h is empty.

Table 06h, A2h contains a temperature-indexed LUT for control of the APC1 voltage. The APC1 LUT can be programmed in 2°C increments over the -40°C to +102°C range. This also contains a temperature-indexed LUT for the APC1 offsets.

The main device located at B2h is used for transmitter 2 control, calibration, alarms, warnings, and monitoring.

Lower Memory, B2h is addressed from 00h–7Fh and contains alarm and warning thresholds, flags, masks, several control registers, PWE, and the table-select byte.

Table 01h, B2h contains alarm and warning enable bytes.

Table 04h, B2h contains a temperature-indexed LUT for control of the MOD2 voltage. The MOD2 LUT can be programmed in 2°C increments over the -40°C to +102°C range. This also contains a temperature-indexed LUT for the MOD2 offsets.

Table 05h, B2h is empty by default. It can be configured to contain the alarm and warning enable bytes from Table 01h, Registers F8h–FFh with the MASK bit enabled (Table 02h, Register 88h). In this case Table 01h is empty.

Table 06h, B2h contains a temperature-indexed LUT for control of the APC2 voltage. The APC2 LUT can be programmed in 2°C increments over the -40°C to +102°C range. This also contains a temperature-indexed LUT for the APC2 offsets.

SFP Controller with Dual LDD Interface

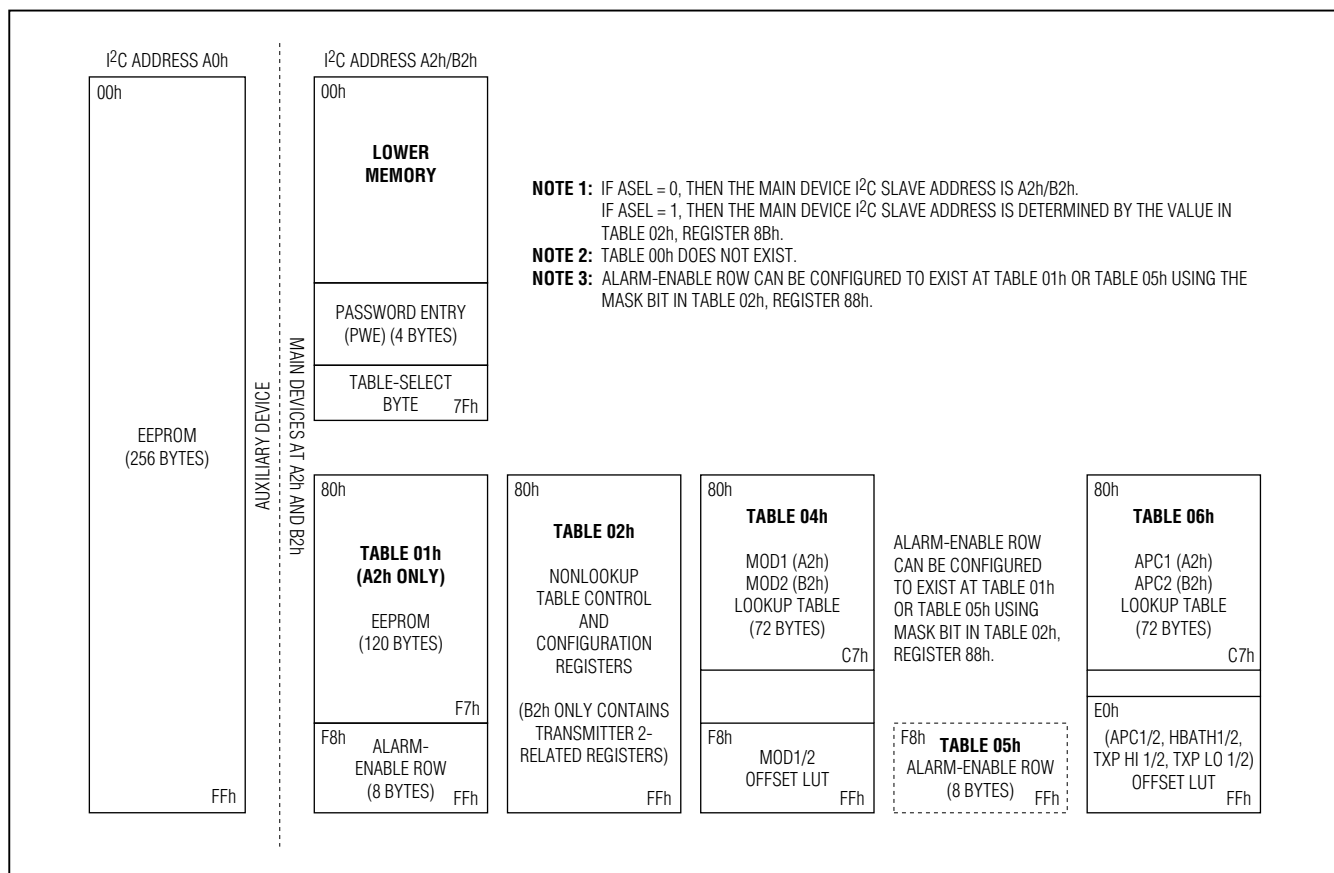

Figure 14. Memory Map

Auxiliary Memory (Device A0h) contains 256 bytes of EE memory accessible from address 00h–FFh. It is selected with the device address of A0h.

See the *Register Descriptions* section for a more complete detail of each byte’s function, as well as for read/write permissions for each byte.

Shadowed EEPROM

Many nonvolatile memory locations (listed within the *Register Descriptions* section) are actually shadowed EEPROM and are controlled by the SEEB bit in Table 02h, Register 80h.

The DS1876 incorporates shadowed EEPROM memory locations for key memory addresses that can be written many times. By default the shadowed EEPROM bit,

SEEB, is not set and these locations act as ordinary EEPROM. By setting SEEB, these locations function like SRAM cells, which allow an infinite number of write cycles without concern of wearing out the EEPROM. This also eliminates the requirement for the EEPROM write time, *t_{WR}*. Because changes made with SEEB enabled do not affect the EEPROM, these changes are not retained through power cycles. The power-on value is the last value written with SEEB disabled. This function can be used to limit the number of EEPROM writes during calibration or to change the monitor thresholds periodically during normal operation helping to reduce the number of times EEPROM is written. Figure 14 shows the memory map and indicates which locations are shadowed EEPROM.

DS1876

SFP Controller with Dual LDD Interface

Register Descriptions

The register maps show each byte/word (2 bytes) in terms of its row in the memory. The first byte in the row is located in memory at the row address (hexadecimal) in the leftmost column. Each subsequent byte on the row is one/two memory locations beyond the previous byte/word's address. A total of 8 bytes are present on each row. For more information about each of these bytes, see the corresponding register description.

Memory Map Access Codes

The following section provides the DS1876 register definitions. Each register or row of registers has an access descriptor that determines the password level required to read or write the memory. Level 2 password is intended for the module manufacture access only. Level 1 password allows another level of protection for items the end consumer wishes to protect. Many registers are always readable, but require password access to write. There are a few registers that cannot be read without password access. The following access codes describe each mode used by the DS1876 with factory settings for the PW_ENA and PW_ENB (Table 02h, Registers C0h–C1h) registers.

ACCESS CODE	READ ACCESS	WRITE ACCESS
<0/_>	At least 1 byte/bit in the row/byte is different than the rest of the row/byte, so look at each byte/bit separately for permissions.	
<1/_>	Read all	Write PW2
<2/_>	Read all	Write not applicable
<3/_>	Read all	Write all, but the DS1876 hardware also writes to these bytes/bits
<4/_>	Read PW2	Write PW2 + mode_bit
<5/_>	Read all	Write all
<6/_>	Read not applicable	Write all
<7/_>	Read PW1	Write PW1
<8/_>	Read PW2	Write PW2
<9/_>	Read not applicable	Write PW2
<10/_>	Read PW2	Write not applicable
<11/_>	Read all	Write PW1

Memory Addresses A0h, A2h, and B2h

There are three separate I²C addresses in the DS1876: A0h, A2h, and B2h. A2h and B2h are used to configure and monitor two transmitters. Transmitter 1 is accessed

using A2h. Transmitter 2 is accessed using B2h. Many of the registers in A2h and B2h are shared registers. These registers can be read and written from both A2h and B2h.

MEMORY CODE	A2h AND B2h REGISTERS
<C> or <_C>	A common memory location is used for A2h and B2h device addresses. Reading or writing to these locations is identical, regardless of using A2h or B2h addresses.
<D> or <_D>	Different memory locations are used for A2h and B2h device addresses.
<M> or <_M>	Mixture of common and different memory locations for A2h and B2h device addresses. See the individual bytes within the row for clarification. If "M" is used on an individual byte, see the expanded bit descriptions to determine which bits are common vs. different.

SFP Controller with Dual LDD Interface

Lower Memory Register Map

LOWER MEMORY									
ROW (HEX)	ROW NAME	WORD 0		WORD 1		WORD 2		WORD 3	
		BYTE 0/8	BYTE 1/9	BYTE 2/A	BYTE 3/B	BYTE 4/C	BYTE 5/D	BYTE 6/E	BYTE 7/F
00	<1/C> THRESHOLD0	TEMP ALARM HI		TEMP ALARM LO		TEMP WARN HI		TEMP WARN LO	
08	<1/C > THRESHOLD1	VCC ALARM HI		VCC ALARM LO		VCC WARN HI		VCC WARN LO	
10	<1/D> THRESHOLD2	BMON ALARM HI		BMON ALARM LO		BMON WARN HI		BMON WARN LO	
18	<1/D> THRESHOLD3	PMON ALARM HI		PMON ALARM LO		PMON WARN HI		PMON WARN LO	
20-40	<1/C > EEPROM	EE		EE		EE		EE	
48-50	<1/D > EEPROM	EE		EE		EE		EE	
58	<1/C > EEPROM	EE	EE	EE	EE	EE	EE	EE	EE
60	<2/M> ADC VALUES0	<C>TEMP VALUE		<C> VCC VALUE		<D>BMON VALUE		<D>PMON VALUE	
68	<0/M> ADC VALUES1	RESERVED		RESERVED		RESERVED		<0/M>STATUS	<3/D> UPDATE
70	<5/D> ALARM/WARN	ALARM3	ALARM2	ALARM1	RESERVED	WARN3	RESERVED	RESERVED	RESERVED
78	<0/M> TABLE SELECT	RESERVED	RESERVED	RESERVED	<6/C> PWE MSW		<6/C> PWE LSW		<5/D> TBL SEL

<C> or <_C> = Common, <D> or <_D> = Different, <M> or <_M> = Mixture of common and different.

Table 01h Register Map

TABLE 01h									
ROW (HEX)	ROW NAME	WORD 0		WORD 1		WORD 2		WORD 3	
		BYTE 0/8	BYTE 1/9	BYTE 2/A	BYTE 3/B	BYTE 4/C	BYTE 5/D	BYTE 6/E	BYTE 7/F
80-F7	<1/C> EEPROM	EE	EE	EE	EE	EE	EE	EE	EE
F8	<7/M>ALARM ENABLE	<M>ALARM EN3	RESERVED	<D>ALARM EN1	RESERVED	<M>WARN EN3	RESERVED	RESERVED	RESERVED

<C> or <_C> = Common, <D> or <_D> = Different, <M> or <_M> = Mixture of common and different.

Note: The ALARM ENABLE bytes (Registers F8h–FFh) can be configured to exist in Table 05h instead of here at Table 01h with the MASK bit (Table 02h, Register 88h). If the row is configured to exist in Table 05h, these location are empty in Table 01h.

The access codes represent the factory default values of PW_ENA and PW_ENB (Table 02h, Registers C0h–C1h). These registers also allow for custom permissions.

ACCESS CODE	<0/_>	<1/_>	<2/_>	<3/_>	<4/_>	<5/_>	<6/_>	<7/_>	<8/_>	<9/_>	<10/_>	<11/_>
Read Access	See each bit/byte separately	All	All	All	PW2	All	N/A	PW1	PW2	N/A	PW2	All
Write Access		PW2	N/A	All and DS1876 Hardware	PW2 + mode bit	All	All	PW1	PW2	PW2	N/A	PW1

DS1876

SFP Controller with Dual LDD Interface

Table 02h Register Map

TABLE 02h (PW2)									
ROW (HEX)	ROW NAME	WORD 0		WORD 1		WORD 2		WORD 3	
		BYTE 0/8	BYTE 1/9	BYTE 2/A	BYTE 3/B	BYTE 4/C	BYTE 5/D	BYTE 6/E	BYTE 7/F
80	<0/C> CONFIG0	<8/C>MODE	<4/C>TINDEX	RESERVED	RESERVED	RESERVED	RESERVED	<10> DEVICE ID	<10> DEVICE VER
88	<8/C> CONFIG1	CNFGA	CNFGB	CNFGC	DEVICE ADDRESS	RANGING ₂	RANGING ₁	RSHIFT ₂	RSHIFT ₁
90	<8/C> SCALE ₀	RESERVED		VCC SCALE		RESERVED		RESERVED	
98	<8/C> SCALE ₁	BMON2 SCALE		PMON2 SCALE		BMON1 SCALE		PMON1 SCALE	
A0	<8/C> OFFSET ₀	INTERNAL TEMP OFFSET*		VCC OFFSET		RESERVED		RESERVED	
A8	<8/C> OFFSET ₁	BMON2 OFFSET		PMON2 OFFSET		BMON1 OFFSET		PMON1 OFFSET	
B0	<9/C> PWD VALUE	PW1 MSW		PW1 LSW		PW2 MSW		PW2 LSW	
B8	<8/C> THRESHOLD	RESERVED	HBIAS2 DAC	HTXP2 DAC	LTXP2 DAC	RESERVED	HBIAS1 DAC	HTXP1 DAC	LTXP1 DAC
C0	<8/C> PWD ENABLE	PW_ENA	PW_ENB	RESERVED	RESERVED	RESERVED	RESERVED	POLARITY	TBLSELPON
C8	<4/C> DAC VALUES	MOD2 DAC		APC2 DAC		MOD1 DAC		APC1 DAC	
D0-FF	EMPTY	EMPTY	EMPTY	EMPTY	EMPTY	EMPTY	EMPTY	EMPTY	EMPTY

<C> or <_/C> = Common, <D> or <_/D> = Different, <M> or <_/M> = Mixture of common and different.

*The final result must be XORed with BB40h before writing to this register.

Table 04h Register Map

TABLE 04h (MODULATION LUT)									
ROW (HEX)	ROW NAME	WORD 0		WORD 1		WORD 2		WORD 3	
		BYTE 0/8	BYTE 1/9	BYTE 2/A	BYTE 3/B	BYTE 4/C	BYTE 5/D	BYTE 6/E	BYTE 7/F
80-C7	<8/D> LUT4	MOD	MOD	MOD	MOD	MOD	MOD	MOD	MOD
C8-F7	EMPTY	EMPTY	EMPTY	EMPTY	EMPTY	EMPTY	EMPTY	EMPTY	EMPTY
F8	<8/D> MOD OFFSET	MOD OFFSET LUT	MOD OFFSET LUT	MOD OFFSET LUT	MOD OFFSET LUT	MOD OFFSET LUT	MOD OFFSET LUT	MOD OFFSET LUT	MOD OFFSET LUT

<C> or <_/C> = Common, <D> or <_/D> = Different, <M> or <_/M> = Mixture of common and different.

The access codes represent the factory default values of PW_ENA and PW_ENB (Table 02h, Registers C0h-C1h). These registers also allow for custom permissions.

ACCESS CODE	<0/_>	<1/_>	<2/_>	<3/_>	<4/_>	<5/_>	<6/_>	<7/_>	<8/_>	<9/_>	<10/_>	<11/_>
Read Access	See each bit/byte separately	All	All	All	PW2	All	N/A	PW1	PW2	N/A	PW2	All
Write Access		PW2	N/A	All and DS1876 Hardware	PW2 + mode bit	All	All	PW1	PW2	PW2	N/A	PW1

SFP Controller with Dual LDD Interface

Table 05h Register Map

TABLE 05h									
ROW (HEX)	ROW NAME	WORD 0		WORD 1		WORD 2		WORD 3	
		BYTE 0/8	BYTE 1/9	BYTE 2/A	BYTE 3/B	BYTE 4/C	BYTE 5/D	BYTE 6/E	BYTE 7/F
80-F7	EMPTY	EMPTY	EMPTY	EMPTY	EMPTY	EMPTY	EMPTY	EMPTY	EMPTY
F8	<7/M> ALARM ENABLE	<M>ALARM EN3	RESERVED	<D>ALARM EN1	RESERVED	<M>WARN EN3	RESERVED	RESERVED	RESERVED

<C> or <_C> = Common, <D> or <_D> = Different, <M> or <_M> = Mixture of common and different.

Note: Table 05h is empty by default. It can be configured to contain the alarm and warning enable bytes from Table 01h, Registers F8h–FFh with the MASK bit enabled (Table 02h, Register 88h). In this case Table 01h is empty.

Table 06h Register Map

TABLE 06h (APC LUT)									
ROW (HEX)	ROW NAME	WORD 0		WORD 1		WORD 2		WORD 3	
		BYTE 0/8	BYTE 1/9	BYTE 2/A	BYTE 3/B	BYTE 4/C	BYTE 5/D	BYTE 6/E	BYTE 7/F
80-C7	<8/D> LUT6	APC LUT	APC LUT	APC LUT	APC LUT	APC LUT	APC LUT	APC LUT	APC LUT
C8-DF	EMPTY	EMPTY	EMPTY	EMPTY	EMPTY	EMPTY	EMPTY	EMPTY	EMPTY
E0	<8/D> HBATH	HBATH LUT	HBATH LUT	HBATH LUT	HBATH LUT	HBATH LUT	HBATH LUT	HBATH LUT	HBATH LUT
E8	<8/D> HTXP	HTXP LUT	HTXP LUT	HTXP LUT	HTXP LUT	HTXP LUT	HTXP LUT	HTXP LUT	HTXP LUT
F0	<8/D> LTXP	LTXP LUT	LTXP LUT	LTXP LUT	LTXP LUT	LTXP LUT	LTXP LUT	LTXP LUT	LTXP LUT
F8	<8/D> APC OFFSET	APC OFFSET LUT	APC OFFSET LUT	APC OFFSET LUT	APC OFFSET LUT	APC OFFSET LUT	APC OFFSET LUT	APC OFFSET LUT	APC OFFSET LUT

<C> or <_C> = Common, <D> or <_D> = Different, <M> or <_M> = Mixture of common and different.

Auxiliary Memory A0h Register Map

AUXILIARY MEMORY (A0h)									
ROW (HEX)	ROW NAME	WORD 0		WORD 1		WORD 2		WORD 3	
		BYTE 0/8	BYTE 1/9	BYTE 2/A	BYTE 3/B	BYTE 4/C	BYTE 5/D	BYTE 6/E	BYTE 7/F
00-7F	<5> AUX EE	EE	EE	EE	EE	EE	EE	EE	EE
80-FF	<5> AUX EE	EE	EE	EE	EE	EE	EE	EE	EE

<C> or <_C> = Common, <D> or <_D> = Different, <M> or <_M> = Mixture of common and different.

The access codes represent the factory default values of PW_ENA and PW_ENB (Table 02h, Registers C0h–C1h). These registers also allow for custom permissions.

ACCESS CODE	<0/_>	<1/_>	<2/_>	<3/_>	<4/_>	<5/_>	<6/_>	<7/_>	<8/_>	<9/_>	<10/_>	<11/_>
Read Access	See each bit/byte separately	All	All	All	PW2	All	N/A	PW1	PW2	N/A	PW2	All
Write Access		PW2	N/A	All and DS1876 Hardware	PW2 + mode bit	All	All	PW1	PW2	PW2	N/A	PW1

DS1876

SFP Controller with Dual LDD Interface

Lower Memory Register Descriptions

Lower Memory, Register 00h–01h: TEMP ALARM HI

Lower Memory, Register 04h–05h: TEMP WARN HI

FACTORY DEFAULT	7FFFh
READ ACCESS	All
WRITE ACCESS	PW2 or (PW1 and WLOWER)
A2h AND B2h MEMORY	Common A2h and B2h memory location
MEMORY TYPE	Nonvolatile (SEE)

00h, 04h	S	2 ⁶	2 ⁵	2 ⁴	2 ³	2 ²	2 ¹	2 ⁰
01h, 05h	2 ⁻¹	2 ⁻²	2 ⁻³	2 ⁻⁴	2 ⁻⁵	2 ⁻⁶	2 ⁻⁷	2 ⁻⁸
	BIT 7							BIT 0

Temperature measurement updates above this two's complement threshold set its corresponding alarm or warning bit. Temperature measurement updates equal to or below this threshold clear its alarm or warning bit.

Lower Memory, Register 02h–03h: TEMP ALARM LO

Lower Memory, Register 06h–07h: TEMP WARN LO

FACTORY DEFAULT	8000h
READ ACCESS	All
WRITE ACCESS	PW2 or (PW1 and WLOWER)
A2h AND B2h MEMORY	Common A2h and B2h memory location
MEMORY TYPE	Nonvolatile (SEE)

02h, 06h	S	2 ⁶	2 ⁵	2 ⁴	2 ³	2 ²	2 ¹	2 ⁰
03h, 07h	2 ⁻¹	2 ⁻²	2 ⁻³	2 ⁻⁴	2 ⁻⁵	2 ⁻⁶	2 ⁻⁷	2 ⁻⁸
	BIT 7							BIT 0

Temperature measurement updates below this two's complement threshold set its corresponding alarm or warning bit. Temperature measurement updates equal to or above this threshold clear its alarm or warning bit.

SFP Controller with Dual LDD Interface

Lower Memory, Register 08h–09h: VCC ALARM HI

Lower Memory, Register 0Ch–0Dh: VCC WARN HI

FACTORY DEFAULT	FFFFh
READ ACCESS	All
WRITE ACCESS	PW2 or (PW1 and WLOWER)
A2h AND B2h MEMORY	Common A2h and B2h memory location
MEMORY TYPE	Nonvolatile (SEE)

08h, 0Ch	2 ¹⁵	2 ¹⁴	2 ¹³	2 ¹²	2 ¹¹	2 ¹⁰	2 ⁹	2 ⁸
09h, 0Dh	2 ⁷	2 ⁶	2 ⁵	2 ⁴	2 ³	2 ²	2 ¹	2 ⁰
	BIT 7							BIT 0

Voltage measurement updates above this unsigned threshold set its corresponding alarm or warning bit.
Voltage measurements equal to or below this threshold clear its alarm or warning bit.

Lower Memory, Register 0Ah–0Bh: VCC ALARM LO

Lower Memory, Register 0Eh–0Fh: VCC WARN LO

FACTORY DEFAULT	0000h
READ ACCESS	All
WRITE ACCESS	PW2 or (PW1 and WLOWER)
A2h AND B2h MEMORY	Common A2h and B2h memory location
MEMORY TYPE	Nonvolatile (SEE)

0Ah, 0Eh	2 ¹⁵	2 ¹⁴	2 ¹³	2 ¹²	2 ¹¹	2 ¹⁰	2 ⁹	2 ⁸
0Bh, 0Fh	2 ⁷	2 ⁶	2 ⁵	2 ⁴	2 ³	2 ²	2 ¹	2 ⁰
	BIT 7							BIT 0

Voltage measurement updates below this unsigned threshold set its corresponding alarm or warning bit. Voltage measurements equal to or above this threshold clear its alarm or warning bit.

DS1876

SFP Controller with Dual LDD Interface

Lower Memory, Register 10h–11h: BMON ALARM HI

Lower Memory, Register 14h–15h: BMON WARN HI

Lower Memory, Register 18h–19h: PMON ALARM HI

Lower Memory, Register 1Ch–1Dh: PMON WARN HI

FACTORY DEFAULT	FFFFh
READ ACCESS	All
WRITE ACCESS	PW2 or (PW1 and WLOWER)
A2h AND B2h MEMORY	Different A2h and B2h memory locations
MEMORY TYPE	Nonvolatile (SEE)

10h, 14h, 18h, 1Ch	2 ¹⁵	2 ¹⁴	2 ¹³	2 ¹²	2 ¹¹	2 ¹⁰	2 ⁹	2 ⁸
11h, 15h, 19h, 1Dh	2 ⁷	2 ⁶	2 ⁵	2 ⁴	2 ³	2 ²	2 ¹	2 ⁰
	BIT 7							BIT 0

Voltage measurement updates above this unsigned threshold set its corresponding alarm or warning bit.
Voltage measurements equal to or below this threshold clear its alarm or warning bit.

Lower Memory, Register 12h–13h: BMON ALARM LO

Lower Memory, Register 16h–17h: BMON WARN LO

Lower Memory, Register 1Ah–1Bh: PMON ALARM LO

Lower Memory, Register 1Eh–1Fh: PMON WARN LO

FACTORY DEFAULT	0000h
READ ACCESS	All
WRITE ACCESS	PW2 or (PW1 and WLOWER)
A2h AND B2h MEMORY	Different A2h and B2h memory locations
MEMORY TYPE	Nonvolatile (SEE)

12h, 16h, 1Ah, 1Eh	2 ¹⁵	2 ¹⁴	2 ¹³	2 ¹²	2 ¹¹	2 ¹⁰	2 ⁹	2 ⁸
13h, 17h, 1Bh, 1Fh	2 ⁷	2 ⁶	2 ⁵	2 ⁴	2 ³	2 ²	2 ¹	2 ⁰
	BIT 7							BIT 0

Voltage measurement updates below this unsigned threshold set its corresponding alarm or warning bit. Voltage measurements equal to or above this threshold clear its alarm or warning bit.

SFP Controller with Dual LDD Interface

Lower Memory, Register 20h–47h: EE

FACTORY DEFAULT	00h
READ ACCESS	All
WRITE ACCESS	PW2 or (PW1 and WLOWER)
A2h AND B2h MEMORY	Common A2h and B2h memory location
MEMORY TYPE	Nonvolatile (EE)

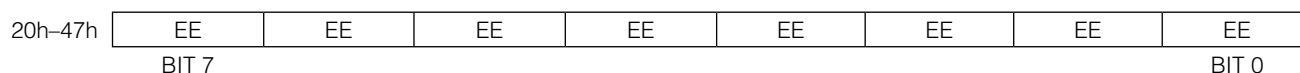

PW2 level access-controlled EEPROM.

Lower Memory, Register 48h–57h: EE

FACTORY DEFAULT	00h
READ ACCESS	All
WRITE ACCESS	PW2 or (PW1 and WLOWER)
A2h AND B2h MEMORY	Different A2h and B2h memory locations
MEMORY TYPE	Nonvolatile (EE)

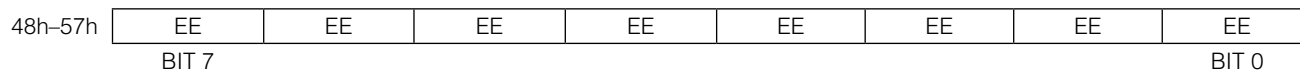

PW2 level access-controlled EEPROM.

Lower Memory, Register 58h–5Fh: EE

FACTORY DEFAULT	00h
READ ACCESS	All
WRITE ACCESS	PW2 or (PW1 and WLOWER)
A2h AND B2h MEMORY	Common A2h and B2h memory location
MEMORY TYPE	Nonvolatile (EE)

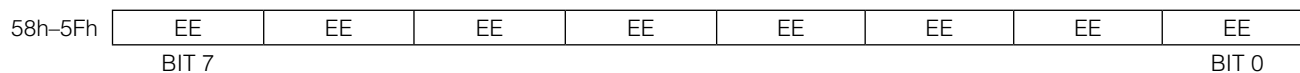

PW2 level access-controlled EEPROM.

DS1876

SFP Controller with Dual LDD Interface

Lower Memory, Register 60h–61h: TEMP VALUE

FACTORY DEFAULT	0000h
READ ACCESS	All
WRITE ACCESS	N/A
A2h AND B2h MEMORY	Common A2h and B2h memory location
MEMORY TYPE	Volatile

60h	S	2^6	2^5	2^4	2^3	2^2	2^1	2^0
61h	2^{-1}	2^{-2}	2^{-3}	2^{-4}	2^{-5}	2^{-6}	2^{-7}	2^{-8}
	BIT 7							BIT 0

Signed two's complement direct-to-temperature measurement.

Lower Memory, Register 62h–63h: Vcc VALUE

POWER-ON VALUE	0000h
READ ACCESS	All
WRITE ACCESS	N/A
A2h AND B2h MEMORY	Common A2h and B2h memory location
MEMORY TYPE	Volatile

62h	2^{15}	2^{14}	2^{13}	2^{12}	2^{11}	2^{10}	2^9	2^8
63h	2^7	2^6	2^5	2^4	2^3	2^2	2^1	2^0
	BIT 7							BIT 0

Left-justified unsigned voltage measurement.

SFP Controller with Dual LDD Interface

Lower Memory, Register 64h–65h: BMON VALUE

Lower Memory, Register 66h–67h: PMON VALUE

POWER-ON VALUE	0000h
READ ACCESS	All
WRITE ACCESS	N/A
A2h AND B2h MEMORY	Different A2h and B2h memory locations
MEMORY TYPE	Volatile

64h, 66h	2 ¹⁵	2 ¹⁴	2 ¹³	2 ¹²	2 ¹¹	2 ¹⁰	2 ⁹	2 ⁸
65h, 67h	2 ⁷	2 ⁶	2 ⁵	2 ⁴	2 ³	2 ²	2 ¹	2 ⁰
	BIT 7							BIT 0

Left-justified unsigned voltage measurement.

Lower Memory, Register 68h–6Dh: RESERVED

POWER-ON VALUE	
READ ACCESS	N/A
WRITE ACCESS	N/A
A2h AND B2h MEMORY	N/A
MEMORY TYPE	N/A

68h, 6Dh	0	0	0	0	0	0	0	0
	BIT 7							BIT 0

These registers are reserved. The value when read is 00h.

DS1876

SFP Controller with Dual LDD Interface

Lower Memory, Register 6Eh: STATUS

POWER-ON VALUE	X0XX 0XXXb
READ ACCESS	All
WRITE ACCESS	See below
A2h AND B2h MEMORY	Mixture of common memory locations and different memory locations (see below)
MEMORY TYPE	Volatile

Write Access	N/A	All	N/A	All	All	N/A	N/A	N/A
6Eh	<D>TXDS	<D>TXDC	<C>IN1S	<C>RSELS	<C>RSELC	<D>TXFS	<D>RAM	<C>RDYB
	BIT 7			BIT 0				

BIT 7	<p>TXDS1 [A2h]: TXD1 status bit. Reflects the logic state of the TXD1 pin (read-only). 0 = TXD1 pin is logic-low. 1 = TXD1 pin is logic-high.</p> <p>TXDS2 [B2h]: TXD2 status bit. Reflects the logic state of the TXD2 pin (read-only). 0 = TXD2 pin is logic-low. 1 = TXD2 pin is logic-high.</p>
BIT 6	<p>TXDC1 [A2h]: TXD1 software control bit. This bit allows for software control that is identical to the TXD1 pin. See the <i>DACs as a Function of Transmit Disable (TXD1, TXD2)</i> section for further information. Its value is wire-ORed with the logic value of the TXD1 pin (writable by all users). 0 = (default) 1 = Forces the device into a TXD1 state regardless of the value of the TXD1 pin.</p> <p>TXDC2 [B2h]: TXD2 software control bit. This bit allows for software control that is identical to the TXD2 pin. See the <i>DACs as a Function of Transmit Disable (TXD1, TXD2)</i> section for further information. Its value is wire-ORed with the logic value of the TXD2 pin (writable by all users). 0 = (default) 1 = Forces the device into a TXD2 state regardless of the value of the TXD2 pin.</p>
BIT 5	<p>IN1S [A2h or B2h]: IN1 status bit. Reflects the logic state of the IN1 pin (read-only). 0 = IN1 pin is logic-low. 1 = IN1 pin is logic-high.</p>
BIT 4	<p>RSELS [A2h or B2h]: RSEL status bit. Reflects the logic state of the RSEL pin (read-only). 0 = RSEL pin is logic-low. 1 = RSEL pin is logic-high.</p>
BIT 3	<p>RSELC [A2h or B2h]: RSEL software control bit. This bit allows for software control that is identical to the RSEL pin. Its value is wire-ORed with the logic value of the RSEL pin to create the RSELOUT pin's logic value (writable by all users). 0 = (default) 1 = Forces the device into a RSEL state regardless of the value of the RSEL pin.</p>
BIT 2	<p>TXFS1 [A2h]: Reflects state of the TXF1 pin (read-only). 0 = TXF1 pin is low. 1 = TXF1 pin is high.</p> <p>TXFS2 [B2h]: Reflects the state of the TXF2 pin (read-only). 0 = TXF2 pin is low. 1 = TXF2 pin is high.</p>
BIT 1	<p>RAM1 [A2h]: Volatile memory location.</p> <p>RAM2 [B2h]: Volatile memory location.</p>
BIT 0	<p>RDYB [A2h or B2h]: Ready bar. 0 = V_{CC} is above POA. 1 = V_{CC} is below POA and/or too low to communicate over the I²C bus.</p>

SFP Controller with Dual LDD Interface

Lower Memory, Register 6Fh: UPDATE

POWER-ON VALUE	00h
READ ACCESS	All
WRITE ACCESS	All and DS1876 hardware
A2h AND B2h MEMORY	Different A2h and B2h memory locations
MEMORY TYPE	Volatile

6Fh	TEMP RDY	VCC RDY	BMON RDY	PMON RDY	RESERVED	RESERVED	RESERVED	RESERVED
	BIT 7							BIT 0

BITS 7:4	TEMP RDY, VCC RDY, BMON RDY, PMON RDY: Update of completed conversions. At power-on, these bits are cleared and are set as each conversion is completed. These bits can be cleared so that a completion of a new conversion is verified.
BITS 3:0	RESERVED

DS1876

SFP Controller with Dual LDD Interface

Lower Memory, Register 70h: ALARM3

POWER-ON VALUE	10h
READ ACCESS	All
WRITE ACCESS	N/A
A2h AND B2h MEMORY	Different A2h and B2h memory locations
MEMORY TYPE	Volatile

70h	TEMP HI	TEMP LO	VCC HI	VCC LO	BMON HI	BMON LO	PMON HI	PMON LO
	BIT 7							BIT 0

BIT 7	TEMP HI: High alarm status for temperature measurement. 0 = (default) Last measurement was equal to or below threshold setting. 1 = Last measurement was above threshold setting.
BIT 6	TEMP LO: Low alarm status for temperature measurement. 0 = (default) Last measurement was equal to or above threshold setting. 1 = Last measurement was below threshold setting.
BIT 5	VCC HI: High alarm status for VCC measurement. 0 = (default) Last measurement was equal to or below threshold setting. 1 = Last measurement was above threshold setting.
BIT 4	VCC LO: Low alarm status for VCC measurement. This bit is set when the VCC supply is below the POA trip point value. It clears itself when a VCC measurement is completed and the value is above the low threshold. 0 = Last measurement was equal to or above threshold setting. 1 = (default) Last measurement was below threshold setting.
BIT 3	BMON HI: High alarm status for BMON measurement. 0 = (default) Last measurement was equal to or below threshold setting. 1 = Last measurement was above threshold setting.
BIT 2	BMON LO: Low alarm status for BMON measurement. 0 = (default) Last measurement was equal to or above threshold setting. 1 = Last measurement was below threshold setting.
BIT 1	PMON HI: High alarm status for PMON measurement. 0 = (default) Last measurement was equal to or below threshold setting. 1 = Last measurement was above threshold setting.
BIT 0	PMON LO: Low alarm status for PMON measurement. 0 = (default) Last measurement was equal to or above threshold setting. 1 = Last measurement was below threshold setting.

SFP Controller with Dual LDD Interface

Lower Memory, Register 71h: ALARM₂

POWER-ON VALUE	00h
READ ACCESS	All
WRITE ACCESS	N/A
A2h AND B2h MEMORY	Mixed A2h and B2h memory locations
MEMORY TYPE	Volatile

71h	RESERVED	RESERVED	RESERVED	RESERVED	RESERVED	<C>TXFOUTS	<D>FETG	<D>TXFINT
	BIT 7							BIT 0

BITS 7:3	RESERVED
BIT 2	TXFOUTS: TXFOUT status. Indicates the state the open-drain output is attempting to achieve. 0 = TXFOUT is pulling low. 1 = TXFOUT is high impedance.
BIT 1	FETG: Status of internal signal FETG. The FETG signal is part of the internal shutdown logic. 0 = (default) FETG is low. 1 = FETG is high.
BIT 0	TXFINT: TXF interrupt. This bit is the wire-ORed logic of all alarms and warnings wire-ANDed with their corresponding enable bits, plus the wire-ORed logic of HBAL, TXP HI, and TXP LO. The enable bits are found in Table 01h/05h, Registers F8h–FFh.

Lower Memory, Register 72h: ALARM₁

POWER-ON VALUE	00h
READ ACCESS	All
WRITE ACCESS	N/A
A2h AND B2h MEMORY	Different A2h and B2h memory locations
MEMORY TYPE	Volatile

72h	RESERVED	RESERVED	RESERVED	RESERVED	HBAL	RESERVED	TXP HI	TXP LO
	BIT 7							BIT 0

BITS 7:4, 2	RESERVED
BIT 3	HBAL: High bias alarm status; fast comparison. A TXD event clears this alarm. 0 = (default) Last comparison was below threshold setting. 1 = Last comparison was above threshold setting.
BIT 1	TXP HI: High alarm status TXP; fast comparison. A TXD event clears this alarm. 0 = (default) Last comparison was below threshold setting. 1 = Last comparison was above threshold setting.
BIT 0	TXP LO: Low alarm status TXP; fast comparison. A TXD event clears this alarm. 0 = (default) Last comparison was above threshold setting. 1 = Last comparison was below threshold setting.

DS1876

SFP Controller with Dual LDD Interface

Lower Memory, Register 73h: RESERVED

POWER-ON VALUE	
READ ACCESS	N/A
WRITE ACCESS	N/A
A2h AND B2h MEMORY	N/A
MEMORY TYPE	N/A

This register is reserved.

Lower Memory, Register 74h: WARN₃

POWER-ON VALUE	10h
READ ACCESS	All
WRITE ACCESS	N/A
A2h AND B2h MEMORY	Different A2h and B2h memory locations
MEMORY TYPE	Volatile

74h	TEMP HI	TEMP LO	VCC HI	VCC LO	BMON HI	BMON LO	PMON HI	PMON LO
	BIT 7				BIT 0			

BIT 7	TEMP HI: High warning status for temperature measurement. 0 = (default) Last measurement was equal to or below threshold setting. 1 = Last measurement was above threshold setting.
BIT 6	TEMP LO: Low warning status for temperature measurement. 0 = (default) Last measurement was equal to or above threshold setting. 1 = Last measurement was below threshold setting.
BIT 5	VCC HI: High warning status for VCC measurement. 0 = (default) Last measurement was equal to or below threshold setting. 1 = Last measurement was above threshold setting.
BIT 4	VCC LO: Low warning status for VCC measurement. This bit is set when the VCC supply is below the POA trip-point value. It clears itself when a VCC measurement is completed and the value is above the low threshold. 0 = Last measurement was equal to or above threshold setting. 1 = (default) Last measurement was below threshold setting.
BIT 3	BMON HI: High warning status for BMON measurement. 0 = (default) Last measurement was equal to or below threshold setting. 1 = Last measurement was above threshold setting.
BIT 2	BMON LO: Low warning status for BMON measurement. 0 = (default) Last measurement was equal to or above threshold setting. 1 = Last measurement was below threshold setting.
BIT 1	PMON HI: High warning status for PMON measurement. 0 = (default) Last measurement was equal to or below threshold setting. 1 = Last measurement was above threshold setting.
BIT 0	PMON LO: Low warning status for PMON measurement. 0 = (default) Last measurement was equal to or above threshold setting. 1 = Last measurement was below threshold setting.

SFP Controller with Dual LDD Interface

Lower Memory, Registers 75h–7Ah: RESERVED MEMORY

POWER-ON VALUE	
READ ACCESS	N/A
WRITE ACCESS	N/A
A2h AND B2h MEMORY	N/A
MEMORY TYPE	N/A

These registers are reserved. The value when read is 00h.

Lower Memory, Registers 7Bh–7Eh: PASSWORD ENTRY (PWE)

POWER-ON VALUE	FFFF FFFFh
READ ACCESS	N/A
WRITE ACCESS	All
A2h AND B2h MEMORY	Common A2h and B2h memory location
MEMORY TYPE	Volatile

7Bh	2 ³¹	2 ³⁰	2 ²⁹	2 ²⁸	2 ²⁷	2 ²⁶	2 ²⁵	2 ²⁴	
7Ch	2 ²³	2 ²²	2 ²¹	2 ²⁰	2 ¹⁹	2 ¹⁸	2 ¹⁷	2 ¹⁶	
7Dh	2 ¹⁵	2 ¹⁴	2 ¹³	2 ¹²	2 ¹¹	2 ¹⁰	2 ⁹	2 ⁸	
7Eh	2 ⁷	2 ⁶	2 ⁵	2 ⁴	2 ³	2 ²	2 ¹	2 ⁰	
	BIT 7							BIT 0	

There are two passwords for the DS1876. Each password is 4 bytes long. The lower level password (PW1) has all the access of a normal user plus those made available with PW1. The higher level password (PW2) has all the access of PW1 plus those made available with PW2. The values of the passwords reside in EEPROM inside PW2 memory. At power-up, all PWE bits are set to 1. All reads at this location are 0.

DS1876

SFP Controller with Dual LDD Interface

Lower Memory, Register 7Fh: TABLE SELECT (TBL SEL)

POWER-ON VALUE	TBLSELPON (Table 02h, Register C7h)
READ ACCESS	All
WRITE ACCESS	All
A2h AND B2h MEMORY	Different A2h and B2h memory locations
MEMORY TYPE	Volatile

7Fh	2 ⁷	2 ⁶	2 ⁵	2 ⁴	2 ³	2 ²	2 ¹	2 ⁰
	BIT 7							BIT 0

The upper memory tables of the DS1876 are accessible by writing the desired table value in this register. The power-on value of this register is defined by the value written to TBLSELPON (Table 02h, Register C7h).

Table 01h Register Descriptions

Table 01h, Register 80h–F7h: EEPROM

POWER-ON VALUE	00h
READ ACCESS	PW2 or (PW1 and RWTBL1A) or (PW1 and RTBL1A)
WRITE ACCESS	PW2 or (PW1 and RWTBL1A)
A2h AND B2h MEMORY	Common A2h and B2h memory location
MEMORY TYPE	Nonvolatile (EE)

80h–F7h	EE	EE	EE	EE	EE	EE	EE	EE
	BIT 7							BIT 0

EEPROM for PW1 and/or PW2 level access.

SFP Controller with Dual LDD Interface

Table 01h, Register F8h: ALARM EN₃

POWER-ON VALUE	00h
READ ACCESS	PW2 or (PW1 and RWTBL1C) or (PW1 and RTBL1C)
WRITE ACCESS	PW2 or (PW1 and RWTBL1C)
A2h AND B2h MEMORY	Mixture of common memory locations and different memory locations (see the descriptions below)
MEMORY TYPE	Nonvolatile (SEE)

F8h	<C>TEMP HI	<C>TEMP LO	<C>VCC HI	<C>VCC LO	<D>BMON HI	<D>BMON LO	<D>PMON HI	<D>PMON LO
	BIT 7				BIT 0			

Layout is identical to ALARM₃ in Lower Memory, Register 70h. Enables alarms to create TXFINT (Lower Memory, Register 71h) logic. The MASK bit (Table 02h, Register 88h) determines whether this memory exists in Table 01h or 05h.

BIT 7	TEMP HI [A2h or B2h]: 0 = Disables interrupt from TEMP HI alarm. 1 = Enables interrupt from TEMP HI alarm.
BIT 6	TEMP LO [A2h or B2h]: 0 = Disables interrupt from TEMP LO alarm. 1 = Enables interrupt from TEMP LO alarm.
BIT 5	VCC HI [A2h or B2h]: 0 = Disables interrupt from VCC HI alarm. 1 = Enables interrupt from VCC HI alarm.
BIT 4	VCC LO [A2h or B2h]: 0 = Disables interrupt from VCC LO alarm. 1 = Enables interrupt from VCC LO alarm.
BIT 3	BMON1 HI [A2h]: 0 = Disables interrupt from BMON1 HI alarm. 1 = Enables interrupt from BMON1 HI alarm. BMON2 HI [B2h]: 0 = Disables interrupt from BMON2 HI alarm. 1 = Enables interrupt from BMON2 HI alarm.
BIT 2	BMON1 LO [A2h]: 0 = Disables interrupt from BMON1 LO alarm. 1 = Enables interrupt from BMON1 LO alarm. BMON2 LO [B2h]: 0 = Disables interrupt from BMON2 LO alarm. 1 = Enables interrupt from BMON2 LO alarm.
BIT 1	PMON1 HI [A2h]: 0 = Disables interrupt from PMON1 HI alarm. 1 = Enables interrupt from PMON1 HI alarm. PMON2 HI [B2h]: 0 = Disables interrupt from PMON2 HI alarm. 1 = Enables interrupt from PMON2 HI alarm.
BIT 0	PMON1 LO [A2h]: 0 = Disables interrupt from PMON1 LO alarm. 1 = Enables interrupt from PMON1 LO alarm. PMON2 LO [B2h]: 0 = Disables interrupt from PMON2 LO alarm. 1 = Enables interrupt from PMON2 LO alarm.

DS1876

SFP Controller with Dual LDD Interface

Table 01h, Register F9h: RESERVED

POWER-ON VALUE	
READ ACCESS	N/A
WRITE ACCESS	N/A
A2h AND B2h MEMORY	N/A
MEMORY TYPE	N/A

This register is reserved.

Table 01h, Register FAh: ALARM EN₁

POWER-ON VALUE	00h
READ ACCESS	PW2 or (PW1 and RWTBL1C) or (PW1 and RTBL1C)
WRITE ACCESS	PW2 or (PW1 and RWTBL1C)
A2h AND B2h MEMORY	Different A2h and B2h memory locations
MEMORY TYPE	Nonvolatile (SEE)

FAh	RESERVED	RESERVED	RESERVED	RESERVED	HBAL	RESERVED	TXP HI	TXP LO
	BIT 7							BIT 0

Layout is identical to ALARM₁ in Lower Memory, Register 72h. Enables alarms to create internal signal FETG (see Figure 9). The MASK bit (Table 02h, Register 88h) determines whether this memory exists in Table 01h or 05h.

BITS 7:4, 2	RESERVED
BIT 3	HBAL: Enables alarm to create internal signal FETG. 0 = Disables interrupt from HBAL alarm. 1 = Enables interrupt from HBAL alarm.
BIT 1	TXP HI: Enables alarm to create internal signal FETG. 0 = Disables interrupt from TXP HI alarm. 1 = Enables interrupt from TXP HI alarm.
BIT 0	TXP LO: Enables alarm to create internal signal FETG. 0 = Disables interrupt from TXP LO alarm. 1 = Enables interrupt from TXP LO alarm.

Table 01h, Register FBh: RESERVED

POWER-ON VALUE	
READ ACCESS	N/A
WRITE ACCESS	N/A
A2h AND B2h MEMORY	N/A
MEMORY TYPE	N/A

This register is reserved.

SFP Controller with Dual LDD Interface

Table 01h, Register FCh: WARN EN₃

POWER-ON VALUE	00h
READ ACCESS	PW2 or (PW1 and RWTBL1C) or (PW1 and RTBL1C)
WRITE ACCESS	PW2 or (PW1 and RWTBL1C)
A2h AND B2h MEMORY	Mixture of common memory locations and different memory locations (see the bit descriptions)
MEMORY TYPE	Nonvolatile (SEE)

FCh	<C>TEMP HI	<C>TEMP LO	<C>VCC HI	<C>VCC LO	<D>BMON HI	<D>BMON LO	<D>PMON HI	<D>PMON LO
	BIT 7				BIT 0			

Layout is identical to WARN₃ in Lower Memory, Register 74h. Enables warnings to create TXFINT (Lower Memory, Register 71h) logic. The MASK bit (Table 02h, Register 88h) determines whether this memory exists in Table 01h or 05h.

BIT 7	TEMP HI [A2h or B2h]: 0 = Disables interrupt from TEMP HI warning. 1 = Enables interrupt from TEMP HI warning.
BIT 6	TEMP LO [A2h or B2h]: 0 = Disables interrupt from TEMP LO warning. 1 = Enables interrupt from TEMP LO warning.
BIT 5	VCC HI [A2h or B2h]: 0 = Disables interrupt from VCC HI warning. 1 = Enables interrupt from VCC HI warning.
BIT 4	VCC LO [A2h or B2h]: 0 = Disables interrupt from VCC LO warning. 1 = Enables interrupt from VCC LO warning.
BIT 3	BMON1 HI [A2h]: 0 = Disables interrupt from BMON1 HI warning. 1 = Enables interrupt from BMON1 HI warning. BMON1 HI [B2h]: 0 = Disables interrupt from BMON2 HI warning. 1 = Enables interrupt from BMON2 HI warning.
BIT 2	BMON1 LO [A2h]: 0 = Disables interrupt from BMON1 LO warning. 1 = Enables interrupt from BMON1 LO warning. BMON2 LO [B2h]: 0 = Disables interrupt from BMON2 LO warning. 1 = Enables interrupt from BMON2 LO warning.
BIT 1	PMON1 HI [A2h]: 0 = Disables interrupt from PMON1 HI warning. 1 = Enables interrupt from PMON1 HI warning. PMON2 HI [B2h]: 0 = Disables interrupt from PMON2 HI warning. 1 = Enables interrupt from PMON2 HI warning.
BIT 0	PMON1 LO [A2h]: 0 = Disables interrupt from PMON1 LO warning. 1 = Enables interrupt from PMON1 LO warning. PMON2 LO [B2h]: 0 = Disables interrupt from PMON2 LO warning. 1 = Enables interrupt from PMON2 LO warning.

DS1876

SFP Controller with Dual LDD Interface

Table 01h, Register FDh–FFh: RESERVED

POWER-ON VALUE	
READ ACCESS	N/A
WRITE ACCESS	N/A
A2h AND B2h MEMORY	N/A
MEMORY TYPE	N/A

These registers are reserved.

Table 02h Register Descriptions

Table 02h, Register 80h: MODE

POWER-ON VALUE	7Fh
READ ACCESS	PW2 or (PW1 and RWTBL2) or (PW1 and RTBL2)
WRITE ACCESS	PW2 or (PW1 and RWTBL2)
A2h AND B2h MEMORY	Common A2h and B2h memory location
MEMORY TYPE	Volatile

80h	SEEB	MOD2EN	QT2EN	APC2EN	AEN	MOD1EN	QT1EN	APC1EN
	BIT 7							BIT 0

BIT 7	<p>SEEB: 0 = (default) Enables EEPROM writes to SEE bytes. 1 = Disables EEPROM writes to SEE bytes during configuration, so that the configuration of the part is not delayed by the EE cycle time. Once the values are known, write this bit to a 0 and write the SEE locations again for data to be written to the EEPROM.</p>
BIT 6	<p>MOD2EN: 0 = MOD2 DAC is writable by the user and the LUT recalls are disabled. This allows the user to interactively test their modules by writing the values for MOD2. The output is updated with the new value at the end of the write cycle. The I²C STOP condition is the end of the write cycle. 1 = (default) Enables automatic control of the LUT for MOD2 DAC.</p>
BIT 5	<p>QT2EN: 0 = QTs (HBIAS, TXP HI, TXP LO) for transmitter 2 are writable by the user and the LUT recalls are disabled. This allows the user to interactively test their modules by writing to the QT thresholds. The thresholds are updated with the new values at the end of the write cycle. The I²C STOP condition is the end of the write cycle. 1 = (default) Enables automatic control of the LUT QTs for transmitter 2.</p>
BIT 4	<p>APC2EN: 0 = APC2 DAC is writable by the user and the LUT recalls are disabled. This allows the user to interactively test their modules by writing the values for APC2. The output is updated with the new value at the end of the write cycle. The I²C STOP condition is the end of the write cycle. 1 = (default) Enables automatic control of the LUT for APC2 DAC.</p>
BIT 3	<p>AEN: 0 = The temperature-calculated index value TINDEX is writable by the user and the updates of calculated indexes are disabled. This allows the user to interactively test their modules by controlling the indexing for the LUTs. The recalled values from the LUTs appear in the DAC registers after the next completion of a temperature conversion. 1 = (default) The temperature-calculated index value TINDEX is used to control the LUTs.</p>

SFP Controller with Dual LDD Interface

Table 02h, Register 80h: MODE (continued)

BIT 2	MOD1EN: 0 = MOD1 DAC is writable by the user and the LUT recalls are disabled. This allows the user to interactively test their modules by writing the values for MOD1. The output is updated with the new value at the end of the write cycle. The I ² C STOP condition is the end of the write cycle. 1 = (default) Enables automatic control of the LUT for MOD1 DAC.
BIT 1	QT1EN: 0 = QTs (HBIAS, TXP HI, TXP LO) for transmitter 1 are writable by the user and the LUT recalls are disabled. This allows the user to interactively test their modules by writing to the QT thresholds. The thresholds are updated with the new values at the end of the write cycle. The I ² C STOP condition is the end of the write cycle. 1 = (default) Enables automatic control of the LUT QTs for transmitter 1.
BIT 0	APC1EN: 0 = APC1 DAC is writable by the user and the LUT recalls are disabled. This allows the user to interactively test their modules by writing the values for APC1. The output is updated with the new value at the end of the write cycle. The I ² C STOP condition is the end of the write cycle. 1 = (default) Enables automatic control of the LUT for APC1 DAC.

Table 02h, Register 81h: TEMPERATURE INDEX (TINDEX)

FACTORY DEFAULT	00h
READ ACCESS	PW2 or (PW1 and RWTBL2) or (PW1 and RTBL2)
WRITE ACCESS	(PW2 and AEN = 0) or (PW1 and RWTBL2 and AEN = 0)
A2h AND B2h MEMORY	Common A2h and B2h memory location
MEMORY TYPE	Volatile

81h	27	26	25	24	23	22	21	20
	BIT 7							BIT 0

Holds the calculated index based on the temperature measurement. This index is used for the address during lookup of Tables 04h and 06h. Temperature measurements below -40°C or above +102°C are clamped to 80h and C7h, respectively. The calculation of TINDEX is as follows:

$$\text{TINDEX} = \frac{\text{Temp_Value} + 40^\circ\text{C}}{2^\circ\text{C}} + 80\text{h}$$

For the temperature-indexed LUTs (2°C), the index used during the lookup function for each table is as follows:

Table 04h (MOD)	1	TINDEX ₆	TINDEX ₅	TINDEX ₄	TINDEX ₃	TINDEX ₂	TINDEX ₁	TINDEX ₀
Table 06h (APC)	1	TINDEX ₆	TINDEX ₅	TINDEX ₄	TINDEX ₃	TINDEX ₂	TINDEX ₁	TINDEX ₀

For the 8-position LUT tables, the following table shows the lookup function:

TINDEX	1000_0xxx	1001_0xxx	1001_1xxx	1010_0xxx	1010_1xxx	1011_0xxx	1011_1xxx	11xx_xxxx
BYTE	F8	F9	FA	FB	FC	FD	FE	FF
TEMP (°C)	< -8	-8 to +8	+8 to +24	+24 to +40	+40 to +56	+56 to +72	+72 to +88	≥ 88

DS1876

SFP Controller with Dual LDD Interface

Table 02h, Register 82h–85h: RESERVED

FACTORY DEFAULT	
READ ACCESS	N/A
WRITE ACCESS	N/A
A2h AND B2h MEMORY	N/A
MEMORY TYPE	N/A

These registers are reserved.

Table 02h, Register 86h: DEVICE ID

FACTORY DEFAULT	76h
READ ACCESS	PW2 or (PW1 and RWTBL2) or (PW1 and RTBL2)
WRITE ACCESS	N/A
MEMORY TYPE	ROM

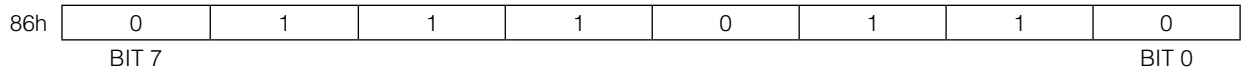

Hardwired connections to show the device ID.

Table 02h, Register 87h: DEVICE VER

FACTORY DEFAULT	DEVICE VERSION
READ ACCESS	PW2 or (PW1 and RWTBL2) or (PW1 and RTBL2)
WRITE ACCESS	N/A
MEMORY TYPE	ROM



Hardwired connections to show the device version.

SFP Controller with Dual LDD Interface

Table 02h, Register 88h: CNFGA

FACTORY DEFAULT	C0h
READ ACCESS	PW2 or (PW1 and RWTBL2) or (PW1 and RTBL2)
WRITE ACCESS	PW2 or (PW1 and RWTBL2)
A2h AND B2h MEMORY	Common A2h and B2h memory location
MEMORY TYPE	Nonvolatile (SEE)

88h	QTHEXT2	QTHEXT1	RESERVED	ASEL	MASK	INVRROUT	INVTXFOUT2	INVTXFOUT1
	BIT 7							BIT 0

BIT 7	<p>QTHEXT2: QT high extension for transmitter 2. 0 = Disabled. TXP HI and HBIAS QT alarms of transmitter 2 immediately create FETG. 1 = (default) Enabled. TXP HI and HBIAS QT alarms of transmitter 2 do not create FETG until the timeout of the TXD_{EXT} time interval.</p>
BIT 6	<p>QTHEXT1: QT high extension for transmitter 1. 0 = Disabled. TXP HI and HBIAS QT alarms of transmitter 1 immediately create FETG. 1 = (default) Enabled. TXP HI and HBIAS QT alarms of transmitter 1 do not create FETG until the timeout of the TXD_{EXT} time interval.</p>
BIT 5	RESERVED
BIT 4	<p>ASEL: Address select. 0 = (default) Device address is A2h for transmitter 1 and B2h for transmitter 2. 1 = The DEVICE ADDRESS register (Table 02h, Register 8Bh) is used to determine the main device address.</p>
BIT 3	<p>MASK: 0 = (default) Alarm-enable row exists at Table 01h, Registers F8h–FFh. Table 05h, Registers F8h–FFh are empty. 1 = Alarm-enable row exists at Table 05h, Registers F8h–FFh. Table 01h, Registers F8h–FFh are empty.</p>
BIT 2	<p>INVRROUT: Allow for inversion of the RSELOUT pin (see Figure 10). 0 = (default) RSELOUT is not inverted. 1 = RSELOUT is inverted.</p>
BIT 1	<p>INVTXFOUT2: Allow for inversion of signal driven by the TXF2 input pin. 0 = (default) TXF2 signal is not inverted. 1 = TXF2 signal is inverted.</p>
BIT 0	<p>INVTXFOUT1: Allow for inversion of signal driven by the TXF1 input pin. 0 = (default) TXF1 signal is not inverted. 1 = TXF1 signal is inverted.</p>

DS1876

SFP Controller with Dual LDD Interface

Table 02h, Register 89h: CNFGB

FACTORY DEFAULT	00h
READ ACCESS	PW2 or (PW1 and RWTBL2) or (PW1 and RTBL2)
WRITE ACCESS	PW2 or (PW1 and RWTBL2)
A2h AND B2h MEMORY	Common A2h and B2h memory location
MEMORY TYPE	Nonvolatile (SEE)

89h	IN1C	INVOUT1	ALATCH2	QTLATCH2	WLATCH2	ALATCH1	QTLATCH1	WLATCH1
	BIT 7							BIT 0

BIT 7	IN1C: IN1 software control bit (see Figure 10). 0 = IN1 pin's logic controls OUT1 pin. 1 = OUT1 is active (bit 6 defines the polarity).
BIT 6	INVOUT1: Inverts the active state for OUT1 (see Figure 10). 0 = Noninverted. 1 = Inverted.
BIT 5	ALATCH2: ADC alarm's comparison latch for transmitter 2. Latches alarms in Lower Memory, Registers 70h–71h. 0 = ADC alarm and flags reflect the status of the last comparison. 1 = ADC alarm flags remain set.
BIT 4	QTLATCH2: QT's comparison latch for transmitter 2. Latches QT alarms in Lower Memory, Registers 72h–73h and 76h. 0 = QT alarm and warning flags reflect the status of the last comparison. 1 = QT alarm and warning flags remain set.
BIT 3	WLATCH2: ADC warning's comparison latch for transmitter 2. Latches warnings in Lower Memory, Registers 74h–75h. 0 = ADC warning flags reflect the status of the last comparison. 1 = ADC warning flags remain set.
BIT 2	ALATCH1: ADC alarm's comparison latch for transmitter 1. Latches alarms in Lower Memory, Registers 70h–71h. 0 = ADC alarm and flags reflect the status of the last comparison. 1 = ADC alarm flags remain set.
BIT 1	QTLATCH1: QT's comparison latch for transmitter 1. Latches QT alarms in Lower Memory, Registers 72h–73h and 76h. 0 = QT alarm and warning flags reflect the status of the last comparison. 1 = QT alarm and warning flags remain set.
BIT 0	WLATCH1: ADC warning's comparison latch for transmitter 1. Latches warnings in Lower Memory, Registers 74h–75h. 0 = ADC warning flags reflect the status of the last comparison. 1 = ADC warning flags remain set.

SFP Controller with Dual LDD Interface

Table 02h, Register 8Ah: CNFGC

FACTORY DEFAULT	00h
READ ACCESS	PW2 or (PW1 and RWTBL2) or (PW1 and RTBL2)
WRITE ACCESS	PW2 or (PW1 and RWTBL2)
A2h AND B2h MEMORY	Common A2h and B2h memory location
MEMORY TYPE	Nonvolatile (SEE)

8Ah	TXDFG2	TXDFLT2	TXDIO2	TXDFG1	TXDFLT1	TXDIO1	RESERVED	RESERVED
	BIT 7						BIT 0	

BIT 7	TXDFG2: See Figure 9. 0 = FETG2, an internal signal, has no effect on TXDOUT2. 1 = FETG2 is enabled and ORed with other possible signals to create TXDOUT2.
BIT 6	TXDFLT2: See Figure 9. 0 = TXF2 pin has no effect on TXDOUT2. 1 = TXF2 pin is enabled and ORed with other possible signals to create TXDOUT2.
BIT 5	TXDIO2: See Figure 9. 0 = (default) TXD2 input signal is enabled and ORed with other possible signals to create TXDOUT2. 1 = TXD2 input signal has no effect on TXDOUT2.
BIT 4	TXDFG1: See Figure 9. 0 = FETG1, an internal signal, has no effect on TXDOUT1. 1 = FETG1 is enabled and ORed with other possible signals to create TXDOUT1.
BIT 3	TXDFLT1: See Figure 9. 0 = TXF1 pin has no effect on TXDOUT1. 1 = TXF1 pin is enabled and ORed with other possible signals to create TXDOUT1.
BIT 2	TXDIO1: See Figure 9. 0 = (default) TXD1 input signal is enabled and ORed with other possible signals to create TXDOUT1. 1 = TXD1 input signal has no effect on TXDOUT1.
BITS 1:0	RESERVED

Table 02h, Register 8Bh: DEVICE ADDRESS

FACTORY DEFAULT	00h
READ ACCESS	PW2 or (PW1 and RWTBL2) or (PW1 and RTBL2)
WRITE ACCESS	PW2 or (PW1 and RWTBL2)
A2h AND B2h MEMORY	Common A2h and B2h memory location
MEMORY TYPE	Nonvolatile (SEE)

8Bh	SEE	SEE	SEE	SEE	2 ³	2 ²	2 ¹	SEE
	BIT 7						BIT 0	

This value becomes the I²C slave address for the main memory when the ASEL bit (Table 02h, Register 88h) is set. If A0h is programmed to this register, the auxiliary memory is disabled. For example, writing xxxx_010x makes the main device addresses A4h and B4h.

DS1876

SFP Controller with Dual LDD Interface

Table 02h, Register 8Ch: RANGING₂

FACTORY DEFAULT	00h
READ ACCESS	PW2 or (PW1 and RWTBL2) or (PW1 and RTBL2)
WRITE ACCESS	PW2 or (PW1 and RWTBL2)
A2h AND B2h MEMORY	Common A2h and B2h memory location
MEMORY TYPE	Nonvolatile (SEE)

8Ch	RESERVED	HBIAS2 ₂	HBIAS2 ₁	HBIAS2 ₀	RESERVED	TXP2 ₂	TXP2 ₁	TXP2 ₀
	BIT 7						BIT 0	

The upper nibble of this byte controls the full-scale range of the QT monitoring for BMON2. The lower nibble of this byte controls the full-scale range for the QT monitoring for PMON2.

BITS 7, 3	RESERVED (default = 0)		
BITS 6:4	HBIAS2[2:0]: HBIAS2 full-scale ranging: 3-bit value to select the full-scale comparison voltage for BMON2. Default is 000b and creates a full scale of 1.25V.		
	HBIAS2[2:0]	% OF 1.25V	FS VOLTAGE (V)
	000b	100.00	1.250
	001b	80.03	1.000
	010b	66.71	0.834
	011b	50.07	0.626
	100b	40.08	0.501
	101b	33.41	0.418
	110b	28.65	0.358
	111b	25.08	0.314
BITS 2:0	TXP2[2:0]: TXP2 full-scale ranging: 3-bit value to select the full-scale comparison voltage for PMON2. Default is 000b and creates a full scale of 2.5V.		
	TXP2[2:0]	% OF 2.5V	FS VOLTAGE (V)
	000b	100.00	2.507
	001b	80.03	2.006
	010b	66.71	1.672
	011b	50.07	1.255
	100b	40.08	1.005
	101b	33.41	0.838
	110b	28.65	0.718
	111b	25.08	0.629

SFP Controller with Dual LDD Interface

Table 02h, Register 8Dh: RANGING₁

FACTORY DEFAULT	00h
READ ACCESS	PW2 or (PW1 and RWTBL2) or (PW1 and RTBL2)
WRITE ACCESS	PW2 or (PW1 and RWTBL2)
A2h AND B2h MEMORY	Common A2h and B2h memory location
MEMORY TYPE	Nonvolatile (SEE)

8Dh	RESERVED	HBIAS ₁₂	HBIAS ₁₁	HBIAS ₁₀	RESERVED	TXP ₁₂	TXP ₁₁	TXP ₁₀	
	BIT 7								BIT 0

The upper nibble of this byte controls the full-scale range of the QT monitoring for BMON1. The lower nibble of this byte controls the full-scale range for the QT monitoring for PMON1.

BITS 7, 3	RESERVED (default = 0)		
BITS 6:4	HBIAS1[2:0]: HBIAS1 full-scale ranging: 3-bit value to select the full-scale comparison voltage for BMON1. Default is 000b and creates a full scale of 1.25V.		
	HBIAS1[2:0]	% OF 1.25V	FS VOLTAGE (V)
	000b	100.00	1.250
	001b	80.03	1.000
	010b	66.71	0.834
	011b	50.07	0.626
	100b	40.08	0.501
	101b	33.41	0.418
BITS 2:0	TXP1[2:0]: TXP1 full-scale ranging: 3-bit value to select the full-scale comparison voltage for PMON1. Default is 000b and creates a full scale of 2.5V.		
	TXP1[2:0]	% OF 2.5V	FS VOLTAGE (V)
	000b	100.00	2.507
	001b	80.03	2.006
	010b	66.71	1.672
	011b	50.07	1.255
	100b	40.08	1.005
	101b	33.41	0.838
110b	28.65	0.718	
111b	25.08	0.629	

DS1876

SFP Controller with Dual LDD Interface

Table 02h, Register 8Eh: RIGHT-SHIFT₂ (RSHIFT₂)

FACTORY DEFAULT	00h
READ ACCESS	PW2 or (PW1 and RWTBL2) or (PW1 and RTBL2)
WRITE ACCESS	PW2 or (PW1 and RWTBL2)
A2h AND B2h MEMORY	Common A2h and B2h memory location
MEMORY TYPE	Nonvolatile (SEE)

8Eh	RESERVED	BMON2 ₂	BMON2 ₁	BMON2 ₀	RESERVED	PMON2 ₂	PMON2 ₁	PMON2 ₀
	BIT 7					BIT 0		

Allows for right-shifting the final answer of BMON2 and PMON2 voltage measurements. This allows for scaling the measurement to the smallest full-scale voltage and then right-shifting the final result so the reading is weighted to the correct LSB.

Table 02h, Register 8Fh: RIGHT-SHIFT₁ (RSHIFT₁)

FACTORY DEFAULT	00h
READ ACCESS	PW2 or (PW1 and RWTBL2) or (PW1 and RTBL2)
WRITE ACCESS	PW2 or (PW1 and RWTBL2)
A2h AND B2h MEMORY	Common A2h and B2h memory location
MEMORY TYPE	Nonvolatile (SEE)

8Fh	RESERVED	BMON1 ₂	BMON1 ₁	BMON1 ₀	RESERVED	PMON1 ₂	PMON1 ₁	PMON1 ₀
	BIT 7					BIT 0		

Allows for right-shifting the final answer of BMON1 and PMON1 voltage measurements. This allows for scaling the measurements to the smallest full-scale voltage and then right-shifting the final result so the reading is weighted to the correct LSB.

Table 02h, Register 90h–91h: RESERVED

FACTORY DEFAULT	
READ ACCESS	N/A
WRITE ACCESS	N/A
A2h AND B2h MEMORY	N/A
MEMORY TYPE	N/A

These registers are reserved.

SFP Controller with Dual LDD Interface

Table 02h, Register 92h–93h: V_{CC} SCALE

Table 02h, Register 94h–97h: RESERVED

Table 02h, Register 98h–99h: BMON2 SCALE

Table 02h, Register 9Ah–9Bh: PMON2 SCALE

Table 02h, Register 9Ch–9Dh: BMON1 SCALE

Table 02h, Register 9Eh–9Fh: PMON1 SCALE

FACTORY CALIBRATED

READ ACCESS PW2 or (PW1 and RWTBL2) or (PW1 and RTBL2)

WRITE ACCESS PW2 or (PW1 and RWTBL2)

A2h AND B2h MEMORY Common A2h and B2h memory location

MEMORY TYPE Nonvolatile (SEE)

92h, 94h, 96h, 98h, 9Ah, 9Ch, 9Eh	2^{15}	2^{14}	2^{13}	2^{12}	2^{11}	2^{10}	2^9	2^8
93h, 95h, 97h, 99h, 9Bh, 9Dh, 9Fh	2^7	2^6	2^5	2^4	2^3	2^2	2^1	2^0
	BIT 7							BIT 0

Controls the scaling or gain of the full-scale voltage measurements. The factory-calibrated value produces an FS voltage of 6.5536V for V_{CC} and 2.5V for BMON2, PMON2, BMON1, and PMON1.

Table 02h, Register A0h–A1h: INTERNAL TEMP OFFSET

FACTORY CALIBRATED

READ ACCESS PW2 or (PW1 and RWTBL2) or (PW1 and RTBL2)

WRITE ACCESS PW2 or (PW1 and RWTBL2)

A2h AND B2h MEMORY Common A2h and B2h memory location

MEMORY TYPE Nonvolatile (SEE)

A0h	S	2^8	2^7	2^6	2^5	2^4	2^3	2^2
A1h	2^1	2^0	2^{-1}	2^{-2}	2^{-3}	2^{-4}	2^{-5}	2^{-6}
	BIT 7							BIT 0

Allows for offset control of temperature measurement if desired. The final result must be XORed with BB40h before writing to this register. Factory calibration contains the desired value for a reading in degrees Celsius.

DS1876

SFP Controller with Dual LDD Interface

Table 02h, Register A2h–A3h: VCC OFFSET

Table 02h, Register A4h–A7h: RESERVED

Table 02h, Register A8h–A9h: BMON2 OFFSET

Table 02h, Register AAh–ABh: PMON2 OFFSET

Table 02h, Register ACh–ADh: BMON1 OFFSET

Table 02h, Register AEh–AFh: PMON1 OFFSET

FACTORY DEFAULT	00h
READ ACCESS	PW2 or (PW1 and RWTBL2) or (PW1 and RTBL2)
WRITE ACCESS	PW2 or (PW1 and RWTBL2)
A2h AND B2h MEMORY	Common A2h and B2h memory location
MEMORY TYPE	Nonvolatile (SEE)

A2h, A4h, A6h, A8h, AAh, ACh, AEh	S	S	2^{15}	2^{14}	2^{13}	2^{12}	2^{11}	2^{10}
A3h, A5h, A7h, A9h, ABh, ADh, AFh	2^9	2^8	2^7	2^6	2^5	2^4	2^3	2^2
	BIT 7							BIT 0

Allows for offset control of these voltage measurements if desired. This number is two's complement.

Table 02h, Register B0h–B3h: PW1

FACTORY DEFAULT	FFFF FFFFh
READ ACCESS	N/A
WRITE ACCESS	PW2 or (PW1 and WPW1)
MEMORY TYPE	Nonvolatile (SEE)

B0h	2^{31}	2^{30}	2^{29}	2^{28}	2^{27}	2^{26}	2^{25}	2^{24}
B1h	2^{23}	2^{22}	2^{21}	2^{20}	2^{19}	2^{18}	2^{17}	2^{16}
B2h	2^{15}	2^{14}	2^{13}	2^{12}	2^{11}	2^{10}	2^9	2^8
B3h	2^7	2^6	2^5	2^4	2^3	2^2	2^1	2^0
	BIT 7							BIT 0

The PWE value is compared against the value written to this location to enable PW1 access. At power-on, the PWE value is set to all ones. Thus, writing these bytes to all ones grants PW1 access on power-on without writing the password entry. All reads of this register are 00h.

SFP Controller with Dual LDD Interface

Table 02h, Register B4h–B7h: PW2

	FACTORY DEFAULT	FFFF FFFFh						
	READ ACCESS	N/A						
	WRITE ACCESS	PW2						
	MEMORY TYPE	Nonvolatile (SEE)						

B4h	2 ³¹	2 ³⁰	2 ²⁹	2 ²⁸	2 ²⁷	2 ²⁶	2 ²⁵	2 ²⁴	
B5h	2 ²³	2 ²²	2 ²¹	2 ²⁰	2 ¹⁹	2 ¹⁸	2 ¹⁷	2 ¹⁶	
B6h	2 ¹⁵	2 ¹⁴	2 ¹³	2 ¹²	2 ¹¹	2 ¹⁰	2 ⁹	2 ⁸	
B7h	2 ⁷	2 ⁶	2 ⁵	2 ⁴	2 ³	2 ²	2 ¹	2 ⁰	
	BIT 7								BIT 0

The PWE value is compared against the value written to this location to enable PW2 access. At power-on, the PWE value is set to all ones. Thus, writing these bytes to all ones grants PW2 access on power-on without writing the password entry. All reads of this register are 00h.

Table 02h, Register B8h: RESERVED

FACTORY DEFAULT	
READ ACCESS	N/A
WRITE ACCESS	N/A
A2h AND B2h MEMORY	N/A
MEMORY TYPE	N/A

This register is reserved.

Table 02h, Register B9h: HBIAS2 DAC

	FACTORY DEFAULT	00h						
	READ ACCESS	PW2 or (PW1 and RWTBL2) or (PW1 and RTBL2)						
	WRITE ACCESS	(PW2 and QT2EN = 0) or (PW1 and RWTBL2 and QT2EN = 0)						
	A2h AND B2h MEMORY	Common A2h and B2h memory location						
	MEMORY TYPE	Volatile						

B9h	2 ⁷	2 ⁶	2 ⁵	2 ⁴	2 ³	2 ²	2 ¹	2 ⁰	
	BIT 7								BIT 0

The digital value used for the HBIAS2 reference and recalled from Table 06h (Registers E0h–E7h) (transmitter 2) at the adjusted memory address found in TINDEX. This register is updated at the end of the temperature conversion. Comparisons greater than V_{HBIAS2} compared against V_{BMON2} create an HBAL alarm.

$$V_{HBIAS2} = \frac{\text{Full Scale}}{256} \times \text{HBIAS2 DAC}$$

DS1876

SFP Controller with Dual LDD Interface

Table 02h, Register BAh: HTXP2 DAC

FACTORY DEFAULT	00h
READ ACCESS	PW2 or (PW1 and RWTBL2) or (PW1 and RTBL2)
WRITE ACCESS	(PW2 and QT2EN = 0) or (PW1 and RWTBL2 and QT2EN = 0)
A2h AND B2h MEMORY	Common A2h and B2h memory location
MEMORY TYPE	Volatile

BAh	2 ⁷	2 ⁶	2 ⁵	2 ⁴	2 ³	2 ²	2 ¹	2 ⁰
	BIT 7							BIT 0

The digital value used for the HTXP2 reference and recalled from Table 06h (Registers E8h–EFh) (transmitter 2) at the adjusted memory address found in TINDEX. This register is updated at the end of the temperature conversion. Comparisons greater than V_{HTXP2} compared against V_{PMON2} create a TXP HI alarm.

$$V_{HTXP2} = \frac{\text{Full Scale}}{256} \times \text{HTXP2 DAC}$$

Table 02h, Register BBh: LTXP2 DAC

FACTORY DEFAULT	00h
READ ACCESS	PW2 or (PW1 and RWTBL2) or (PW1 and RTBL2)
WRITE ACCESS	(PW2 and QT2EN = 0) or (PW1 and RWTBL2 and QT2EN = 0)
A2h AND B2h MEMORY	Common A2h and B2h memory location
MEMORY TYPE	Volatile

BBh	2 ⁷	2 ⁶	2 ⁵	2 ⁴	2 ³	2 ²	2 ¹	2 ⁰
	BIT 7							BIT 0

The digital value used for the LTXP2 reference and recalled from Table 06h (Registers F0h–F7h) (transmitter 2) at the adjusted memory address found in TINDEX. This register is updated at the end of the temperature conversion. Comparisons less than V_{LTXP2} compared against V_{PMON2} create a TXP LO alarm.

$$V_{LTXP2} = \frac{\text{Full Scale}}{256} \times \text{LTXP2 DAC}$$

Table 02h, Register BCh: RESERVED

FACTORY DEFAULT	
READ ACCESS	N/A
WRITE ACCESS	N/A
A2h AND B2h MEMORY	N/A
MEMORY TYPE	N/A

This register is reserved.

SFP Controller with Dual LDD Interface

Table 02h, Register BDh: HBIAS1 DAC

FACTORY DEFAULT	00h
READ ACCESS	PW2 or (PW1 and RWTBL2) or (PW1 and RTBL2)
WRITE ACCESS	(PW2 and QT1EN = 0) or (PW1 and RWTBL2 and QT1EN = 0)
A2h AND B2h MEMORY	Common A2h and B2h memory location
MEMORY TYPE	Volatile

BDh	27	26	25	24	23	22	21	20
	BIT 7							BIT 0

The digital value used for the HBIAS1 reference and recalled from Table 06h (Registers E0h–E7h) (transmitter 1) at the adjusted memory address found in TINDEX. This register is updated at the end of the temperature conversion. Comparisons greater than V_{HBIAS1} compared against V_{BMON1} create an HBAL alarm.

$$V_{HBIAS1} = \frac{\text{Full Scale}}{256} \times \text{HBIAS1 DAC}$$

Table 02h, Register BEh: HTXP1 DAC

FACTORY DEFAULT	00h
READ ACCESS	PW2 or (PW1 and RWTBL2) or (PW1 and RTBL2)
WRITE ACCESS	(PW2 and QT1EN = 0) or (PW1 and RWTBL2 and QT1EN = 0)
A2h AND B2h MEMORY	Common A2h and B2h memory location
MEMORY TYPE	Volatile

BEh	27	26	25	24	23	22	21	20
	BIT 7							BIT 0

The digital value used for the HTXP1 reference and recalled from Table 06h (Registers E8h–EFh) (transmitter 1) at the adjusted memory address found in TINDEX. This register is updated at the end of the temperature conversion. Comparisons great than V_{HTXP1} compared against V_{PMON1} create a TXP HI alarm.

$$V_{HTXP1} = \frac{\text{Full Scale}}{256} \times \text{HTXP1 DAC}$$

Table 02h, Register BFh: LTXP1 DAC

FACTORY DEFAULT	00h
READ ACCESS	PW2 or (PW1 and RWTBL2) or (PW1 and RTBL2)
WRITE ACCESS	(PW2 and QT1EN = 0) or (PW1 and RWTBL2 and QT1EN = 0)
A2h AND B2h MEMORY	Common A2h and B2h memory location
MEMORY TYPE	Volatile

BFh	27	26	25	24	23	22	21	20
	BIT 7							BIT 0

The digital value used for the LTXP1 reference and recalled from Table 06h (Registers F0h–F7h) (transmitter 1) at the adjusted memory address found in TINDEX. This register is updated at the end of the temperature conversion. Comparisons less than V_{LTXP1} compared against V_{PMON1} create a TXP LO alarm.

$$V_{LTXP1} = \frac{\text{Full Scale}}{256} \times \text{LTXP1 DAC}$$

DS1876

SFP Controller with Dual LDD Interface

Table 02h, Register C0h: PW_ENA

FACTORY DEFAULT	10h
READ ACCESS	PW2 or (PW1 and RWTBL2) or (PW1 and RTBL2)
WRITE ACCESS	PW2 or (PW1 and RWTBL2)
A2h AND B2h MEMORY	Common A2h and B2h memory location
MEMORY TYPE	Nonvolatile (SEE)

C0h	RESERVED	RWTBL1C	RWTBL2	RWTBL1A	RWTBL1B	WLOWER	WAUXA	WAUXB
	BIT 7							BIT 0

BIT 7	RESERVED
BIT 6	RWTBL1C: Table 01h or 05h bytes F8–FFh. Table address is dependent on MASK bit (Table 02h, Register 88h). 0 = (default) Read and write access for PW2 only. 1 = Read and write access for both PW1 and PW2.
BIT 5	RWTBL2: Table 02h. Writing a nonvolatile value to this bit requires PW2 access. 0 = (default) Read and write access for PW2 only. 1 = Read and write access for both PW1 and PW2.
BIT 4	RWTBL1A: Table 01h, Registers 80h–BFh. 0 = Read and write access for PW2 only. 1 = (default) Read and write access for both PW1 and PW2.
BIT 3	RWTBL1B: Table 01h, Registers C0h–F7h. 0 = (default) Read and write access for PW2 only. 1 = Read and write access for both PW1 and PW2.
BIT 2	WLOWER: Bytes 00h–5Fh in main memory. All users can read this area. 0 = (default) Write access for PW2 only. 1 = Write access for both PW1 and PW2.
BIT 1	WAUXA: Auxiliary memory, Registers 00h–7Fh. All users can read this area. 0 = (default) Write access for PW2 only. 1 = Write access for both PW1 and PW2.
BIT 0	WAUXB: Auxiliary memory, Registers 80h–FFh. All users can read this area. 0 = (default) Write access for PW2 only. 1 = Write access for both PW1 and PW2.

SFP Controller with Dual LDD Interface

Table 02h, Register C1h: PW_ENB

FACTORY DEFAULT	03h
READ ACCESS	PW2 or (PW1 and RWTBL2) or (PW1 and RTBL2)
WRITE ACCESS	PW2 or (PW1 and RWTBL2)
A2h AND B2h MEMORY	Common A2h and B2h memory location
MEMORY TYPE	Nonvolatile (SEE)

C1h	RWTBL46	RTBL1C	RTBL2	RTBL1A	RTBL1B	WPW1	WAUXAU	WAUXBU	
	BIT 7								BIT 0

BIT 7	RWTBL46: Tables 04h and 06h. 0 = (default) Read and write access for PW2 only. 1 = Read and write access for PW1 and PW2.
BIT 6	RTBL1C: Table 01h or Table 05h, Registers F8h–FFh. Table address is dependent on MASK bit (Table 02h, Register 88h). 0 = (default) Read and write access for PW2 only. 1 = Read access for PW1 and PW2.
BIT 5	RTBL2: Table 02h. 0 = (default) Read and write access for PW2 only. 1 = Read access for PW1 and PW2.
BIT 4	RTBL1A: Table 01h, Registers 80h–BFh. 0 = (default) Read and write access for PW2 only. 1 = Read access for PW1 and PW2.
BIT 3	RTBL1B: Table 01h, Registers C0h–F7h. 0 = (default) Read and write access for PW2 only. 1 = Read access for PW1 and PW2.
BIT 2	WPW1: Register PW1 (Table 02h, Registers B0h–B3h). For security purposes these registers are not readable. 0 = (default) Write access for PW2 only. 1 = Write access for PW1 and PW2.
BIT 1	WAUXAU: Auxiliary memory, Registers 00h–7Fh. All users can read this area. 0 = Write access for PW2 only. 1 = (default) Write access for user, PW1, and PW2.
BIT 0	WAUXBU: Auxiliary memory, Registers 80h–FFh. All users can read this area. 0 = Write access for PW2 only. 1 = (default) Write access for user, PW1, and PW2.

Table 02h, Register C2h–C5h: RESERVED

FACTORY DEFAULT	
READ ACCESS	N/A
WRITE ACCESS	N/A
A2h AND B2h MEMORY	N/A
MEMORY TYPE	N/A

These registers are reserved.

DS1876

SFP Controller with Dual LDD Interface

Table 02h, Register C6h: POLARITY

FACTORY DEFAULT	0Fh
READ ACCESS	PW2 or (PW1 and RWTBL2) or (PW1 and RTBL2)
WRITE ACCESS	PW2 or (PW1 and RWTBL2)
A2h AND B2h MEMORY	Common A2h and B2h memory location
MEMORY TYPE	Nonvolatile (SEE)

C6h	RESERVED	RESERVED	RESERVED	RESERVED	MOD2P	APC2P	MOD1P	APC1P
	BIT 7							BIT 0

BITS 7:4	RESERVED
BIT 3	<p>MOD2P: MOD2 DAC polarity. The MOD2 DAC (Table 02h, Registers C8h–C9h) range is 000h–3FFh. A setting of 000h creates a pulse-density of zero and 3FFh creates a pulse-density of 1023/1024. This polarity bit allows the user to use GND or VREFIN as the reference. The power-on of MOD2 DAC is 000h; thus an application that needs VREFIN to be the off state should use the inverted polarity.</p> <p>0 = Normal polarity. A setting of 000h results in a pulse-density output of zero held at GND, and a setting of 3FFh results in a pulsed-density output of 1023/1024 held mostly at VREFIN.</p> <p>1 = Inverted polarity. A setting of 000h results in a pulse-density output of zero held at VREFIN, and a setting of 3FFh results in a pulsed-density output of 1023/1024 held mostly at GND.</p>
BIT 2	<p>APC2P: APC2 DAC polarity. The APC2 DAC (Table 02h, Registers CAh–CBh) range is 000h–3FFh. A setting of 000h creates a pulse-density of zero, and 3FFh creates a pulse-density of 1023/1024. This polarity bit allows the user to use GND or VREFIN as the reference. The power-on of APC DAC is 000h; thus an application that needs VREFIN to be the off state should use the inverted polarity.</p> <p>0 = Normal polarity. A setting of 000h results in a pulse-density output of zero held at GND, and a setting of 3FFh results in a pulsed-density output of 1023/1024 held mostly at VREFIN.</p> <p>1 = Inverted polarity. A setting of 000h results in a pulse-density output of zero held at VREFIN, and a setting of 3FFh results in a pulsed-density output of 1023/1024 held mostly at GND.</p>
BIT 1	<p>MOD1P: MOD1 DAC polarity. The MOD1 DAC (Table 02h, Registers CCh–CDh) range is 000h–3FFh. A setting of 000h creates a pulse-density of zero and 3FFh creates a pulse-density of 1023/1024. This polarity bit allows the user to use GND or VREFIN as the reference. The power-on of MOD1 DAC is 000h; thus an application that needs VREFIN to be the off state should use the inverted polarity.</p> <p>0 = Normal polarity. A setting of 000h results in a pulse-density output of zero held at GND, and a setting of 3FFh results in a pulsed-density output of 1023/1024 held mostly at VREFIN.</p> <p>1 = Inverted polarity. A setting of 000h results in a pulse-density output of zero held at VREFIN, and a setting of 3FFh results in a pulsed-density output of 1023/1024 held mostly at GND.</p>
BIT 0	<p>APC1P: APC1 DAC polarity. The APC1 DAC (Table 02h, Registers CEh–CFh) range is 000h–3FFh. A setting of 000h creates a pulse-density of zero, and 3FFh creates a pulse-density of 1023/1024. This polarity bit allows the user to use GND or VREFIN as the reference. The power-on of APC1 DAC is 000h; thus an application that needs VREFIN to be the off state should use the inverted polarity.</p> <p>0 = Normal polarity. A setting of 000h results in a pulse-density output of zero held at GND, and a setting of 3FFh results in a pulsed-density output of 1023/1024 held mostly at VREFIN.</p> <p>1 = Inverted polarity. A setting of 000h results in a pulse-density output of zero held at VREFIN, and a setting of 3FFh results in a pulsed-density output of 1023/1024 held mostly at GND.</p>

SFP Controller with Dual LDD Interface

Table 02h, Register C7h: TBLSELPON

FACTORY DEFAULT	00h
READ ACCESS	PW2 or (PW1 and RWTBL2) or (PW1 and RTBL2)
WRITE ACCESS	PW2 or (PW1 and RWTBL2)
A2h AND B2h MEMORY	Common A2h and B2h memory location
MEMORY TYPE	Nonvolatile (SEE)

C7h	2 ⁷	2 ⁶	2 ⁵	2 ⁴	2 ³	2 ²	2 ¹	2 ⁰
	BIT 7							BIT 0

Chooses the initial value for the TBL SEL byte (Lower Memory, Register 7Fh) at power-on.

Table 02h, Register C8h–C9h: MOD2 DAC

FACTORY DEFAULT	0000h
READ ACCESS	PW2 or (PW1 and RWTBL2) or (PW1 and RTBL2)
WRITE ACCESS	(PW2 and MOD2EN = 0) or (PW1 and RWTBL2 and MOD2EN = 0)
A2h AND B2h MEMORY	Common A2h and B2h memory location
MEMORY TYPE	Volatile

C8h	0	0	0	0	0	0	2 ⁹	2 ⁸
C9h	2 ⁷	2 ⁶	2 ⁵	2 ⁴	2 ³	2 ²	2 ¹	2 ⁰
	BIT 7							BIT 0

The digital value used for MOD2 DAC. It is the result of LUT4 plus MOD2 OFFSET times 4 recalled from Table 04h (Registers F8h–FFh) at the adjusted memory address found in TINDEX. This register is updated at the end of the temperature conversion.

$$\text{MOD2 DAC} = \text{LUT4} + \text{MOD2 OFFSET} \times 4$$

$$V_{\text{MOD2}} = \frac{V_{\text{REFIN}}}{1024} \times \text{MOD2 DAC}$$

DS1876

SFP Controller with Dual LDD Interface

Table 02h, Register CAh–CBh: APC2 DAC

FACTORY DEFAULT	0000h
READ ACCESS	PW2 or (PW1 and RWTBL2) or (PW1 and RTBL2)
WRITE ACCESS	(PW2 and APC2EN = 0) or (PW1 and RWTBL2 and APC2EN = 0)
A2h AND B2h MEMORY	Common A2h and B2h memory location
MEMORY TYPE	Volatile

CAh	0	0	0	0	0	0	2 ⁹	2 ⁸
CBh	2 ⁷	2 ⁶	2 ⁵	2 ⁴	2 ³	2 ²	2 ¹	2 ⁰
	BIT 7				BIT 0			

The digital value used for APC2 DAC. It is the result of LUT6 plus APC2 OFFSET times 4 recalled from Table 06h (Registers F8h–FFh) at the adjusted memory address found in TINDEX. This register is updated at the end of the temperature conversion.

$$\text{APC2 DAC} = \text{LUT6} + \text{APC2 OFFSET} \times 4$$

$$V_{\text{APC2}} = \frac{V_{\text{REFIN}}}{1024} \times \text{APC2 DAC}$$

Table 02h, Register CCh–CDh: MOD1 DAC

FACTORY DEFAULT	0000h
READ ACCESS	PW2 or (PW1 and RWTBL2) or (PW1 and RTBL2)
WRITE ACCESS	(PW2 and MOD1EN = 0) or (PW1 and RWTBL2 and MOD1EN = 0)
A2h AND B2h MEMORY	Common A2h and B2h memory location
MEMORY TYPE	Volatile

CCh	0	0	0	0	0	0	2 ⁹	2 ⁸
CDh	2 ⁷	2 ⁶	2 ⁵	2 ⁴	2 ³	2 ²	2 ¹	2 ⁰
	BIT 7				BIT 0			

The digital value used for MOD1 DAC. It is the result of LUT4 plus MOD1 OFFSET times 4 recalled from Table 04h (Registers F8h–FFh) at the adjusted memory address found in TINDEX. This register is updated at the end of the temperature conversion.

$$\text{MOD1 DAC} = \text{LUT4} + \text{MOD1 OFFSET} \times 4$$

$$V_{\text{MOD1}} = \frac{V_{\text{REFIN}}}{1024} \times \text{MOD1 DAC}$$

SFP Controller with Dual LDD Interface

Table 02h, Register CEh–CFh: APC1 DAC

FACTORY DEFAULT	0000h
READ ACCESS	PW2 or (PW1 and RWTBL2) or (PW1 and RTBL2)
WRITE ACCESS	(PW2 and APC1EN = 0) or (PW1 and RWTBL2 and APC1EN = 0)
A2h AND B2h MEMORY	Common A2h and B2h memory location
MEMORY TYPE	Volatile

CEh	0	0	0	0	0	0	2 ⁹	2 ⁸
CFh	2 ⁷	2 ⁶	2 ⁵	2 ⁴	2 ³	2 ²	2 ¹	2 ⁰
	BIT 7				BIT 0			

The digital value used for APC1 DAC. It is the result of LUT6 plus APC1 OFFSET times 4 recalled from Table 06h (Registers F8h–FFh) at the adjusted memory address found in TINDEX. This register is updated at the end of the temperature conversion.

$$\text{APC1 DAC} = \text{LUT6} + \text{APC1 OFFSET} \times 4$$

$$V_{\text{APC1}} = \frac{V_{\text{REFIN}}}{1024} \times \text{APC1 DAC}$$

Table 02h, Register D0h–FFh: EMPTY

FACTORY DEFAULT	00h
READ ACCESS	N/A
WRITE ACCESS	N/A
A2h AND B2h MEMORY	N/A
MEMORY TYPE	None

These registers do not exist.

DS1876

SFP Controller with Dual LDD Interface

Table 04h Register Descriptions

Table 04h, Register 80h–C7h: MODULATION LUT (MOD)

FACTORY DEFAULT	00h
READ ACCESS	PW2 or (PW1 and RWTBL46)
WRITE ACCESS	PW2 or (PW1 and RWTBL46)
A2h AND B2h MEMORY	Different A2h and B2h memory locations
MEMORY TYPE	Nonvolatile (EE)

80h–C7h	2 ⁷	2 ⁶	2 ⁵	2 ⁴	2 ³	2 ²	2 ¹	2 ⁰
	BIT 7							BIT 0

Digital value for the MOD1 DAC (A2h address) and MOD2 DAC (B2h address) outputs. The MODULATION LUT is a set of registers assigned to hold the temperature profile for the MOD1 and MOD2 DACs. The temperature measurement is used to index the LUT (TINDEX, Table 02h, Register 81h) in 2°C increments from -40°C to +102°C, starting at 80h in Table 04h. Register 80h defines the -40°C to -38°C MOD output, Register 81h defines -38°C to -36°C MOD output, and so on. Values recalled from this EEPROM memory table are written into the MOD1 and MOD2 DACs (Table 02h, Registers C8h–C9h, CCh–CDh) locations that hold the values until the next temperature conversion. The part can be placed into a manual mode (MOD1EN and MOD2EN bits, Table 02h, Register 80h), where MOD1 and MOD2 DACs are directly controlled for calibration. If the temperature compensation functionality is not required, program the entire Table 04h to the desired modulation setting.

Table 02h, Register C8h–F7h: EMPTY

FACTORY DEFAULT	00h
READ ACCESS	N/A
WRITE ACCESS	N/A
A2h AND B2h MEMORY	N/A
MEMORY TYPE	None

These registers do not exist.

SFP Controller with Dual LDD Interface

Table 04h, Register F8h–FFh: MOD OFFSET LUT

FACTORY DEFAULT	00h
READ ACCESS	PW2 or (PW1 and RWTBL46)
WRITE ACCESS	PW2 or (PW1 and RWTBL46)
A2h AND B2h MEMORY	Different A2h and B2h memory locations
MEMORY TYPE	Nonvolatile (EE)

F8h–FFh	2 ⁹	2 ⁸	2 ⁷	2 ⁶	2 ⁵	2 ⁴	2 ³	2 ²
	BIT 7							BIT 0

The digital value for the temperature offset of the MOD1 and MOD2 DAC outputs.

F8h	Less than or equal to -8°C
F9h	Greater than -8°C up to +8°C
FAh	Greater than +8°C up to +24°C
FBh	Greater than +24°C up to +40°C
FCh	Greater than +40°C up to +56°C
FDh	Greater than +56°C up to +72°C
FEh	Greater than +72°C up to +88°C
FFh	Greater than +88°C

The MOD DAC is a 10-bit value. The MODULATION LUT is an 8-bit LUT. The MOD OFFSET LUT times 4 plus the MODULATION LUT makes use of the entire 10-bit range.

Table 06h Register Descriptions

Table 06h, Register 80h–C7h: APC LUT

FACTORY DEFAULT	00h
READ ACCESS	PW2 or (PW1 and RWTBL46)
WRITE ACCESS	PW2 or (PW1 and RWTBL46)
A2h AND B2h MEMORY	Different A2h and B2h memory locations
MEMORY TYPE	Nonvolatile (EE)

80h–C7h	2 ⁷	2 ⁶	2 ⁵	2 ⁴	2 ³	2 ²	2 ¹	2 ⁰
	BIT 7							BIT 0

The digital value for the APC1 DAC (A2h address) and APC2 DAC (B2h address) outputs. The APC LUT is a set of registers assigned to hold the temperature profile for the APC1 and APC2 DACs. The temperature measurement is used to index the LUT (TINDEX, Table 02h, Register 81h) in 2°C increments from -40°C to +102°C, starting at 80h. Register 80h defines the -40°C to -38°C APC output, Register 81h defines -38°C to -36°C APC output, and so on. Values recalled from this EEPROM memory table are written into the APC1 and APC2 DACs (Table 02h, Registers CAh–CBh, CEh–CFh) locations that hold the values until the next temperature conversion. The part can be placed into a manual mode (APC1EN and APC2EN bits, Table 02h, Register 80h), where APC1 and APC2 DACs are directly controlled for calibration. If the temperature compensation functionality is not required, program the entire Table 06h to the desired APC setting.

DS1876

SFP Controller with Dual LDD Interface

Table 06h, Register C8h–DFh: EMPTY

FACTORY DEFAULT	00h
READ ACCESS	N/A
WRITE ACCESS	N/A
A2h AND B2h MEMORY	N/A
MEMORY TYPE	None

These registers do not exist.

Table 06h, Register E0h–E7h: HBATH LUT

FACTORY DEFAULT	00h
READ ACCESS	PW2 or (PW1 and RWTBL46)
WRITE ACCESS	PW2 or (PW1 and RWTBL46)
A2h AND B2h MEMORY	Different A2h and B2h memory locations
MEMORY TYPE	Nonvolatile (EE)

E0h–E7h	2 ⁷	2 ⁶	2 ⁵	2 ⁴	2 ³	2 ²	2 ¹	2 ⁰
	BIT 7							BIT 0

The high bias alarm threshold (HBATH) LUT is used to temperature compensate the bias QT threshold (HBIAS). The table below shows the range of temperature for each byte's location. The table shows a rising temperature; for a falling temperature there is 1°C of hysteresis.

E0h	Less than or equal to -8°C
E1h	Greater than -8°C up to +8°C
E2h	Greater than +8°C up to +24°C
E3h	Greater than +24°C up to +40°C
E4h	Greater than +40°C up to +56°C
E5h	Greater than +56°C up to +72°C
E6h	Greater than +72°C up to +88°C
E7h	Greater than +88°C

SFP Controller with Dual LDD Interface

Table 06h, Register E8h–EFh: HTXP LUT

FACTORY DEFAULT	00h
READ ACCESS	PW2 or (PW1 and RWTBL46)
WRITE ACCESS	PW2 or (PW1 and RWTBL46)
A2h AND B2h MEMORY	Different A2h and B2h memory locations
MEMORY TYPE	Nonvolatile (EE)

E8h–EFh	2 ⁷	2 ⁶	2 ⁵	2 ⁴	2 ³	2 ²	2 ¹	2 ⁰
	BIT 7				BIT 0			

The HTXP LUT is used to temperature compensate the transmit power-high QT threshold (TXP HI). The table below shows the range of temperature for each byte's location. The table shows a rising temperature; for a falling temperature there is 1°C of hysteresis.

E8h	Less than or equal to -8°C
E9h	Greater than -8°C up to +8°C
EAh	Greater than +8°C up to +24°C
EBh	Greater than +24°C up to +40°C
ECh	Greater than +40°C up to +56°C
EDh	Greater than +56°C up to +72°C
EEh	Greater than +72°C up to +88°C
EFh	Greater than +88°C

Table 06h, Register F0h–F7h: LTXP LUT

FACTORY DEFAULT	00h
READ ACCESS	PW2 or (PW1 and RWTBL46)
WRITE ACCESS	PW2 or (PW1 and RWTBL46)
A2h AND B2h MEMORY	Different A2h and B2h memory locations
MEMORY TYPE	Nonvolatile (EE)

F0h–F7h	2 ⁷	2 ⁶	2 ⁵	2 ⁴	2 ³	2 ²	2 ¹	2 ⁰
	BIT 7				BIT 0			

The LTXP LUT is used to temperature compensate the transmit power-low QT threshold (TXP LO). The table below shows the range of temperature for each byte's location. The table shows a rising temperature; for a falling temperature there is 1°C of hysteresis.

F0h	Less than or equal to -8°C
F1h	Greater than -8°C up to +8°C
F2h	Greater than +8°C up to +24°C
F3h	Greater than +24°C up to +40°C
F4h	Greater than +40°C up to +56°C
F5h	Greater than +56°C up to +72°C
F6h	Greater than +72°C up to +88°C
F7h	Greater than +88°C

DS1876

SFP Controller with Dual LDD Interface

Table 06h, Register F8h–FFh: APC OFFSET LUT

FACTORY DEFAULT	00h
READ ACCESS	PW2 or (PW1 and RWTBL46)
WRITE ACCESS	PW2 or (PW1 and RWTBL46)
A2h AND B2h MEMORY	Different A2h and B2h memory locations
MEMORY TYPE	Nonvolatile (EE)

F8h–FFh	2 ⁹	2 ⁸	2 ⁷	2 ⁶	2 ⁵	2 ⁴	2 ³	2 ²
	BIT 7							BIT 0

The digital value for the temperature offset of the APC1 and APC2 DAC outputs.

F8h	Less than or equal to -8°C
F9h	Greater than -8°C up to +8°C
FAh	Greater than +8°C up to +24°C
FBh	Greater than +24°C up to +40°C
FCh	Greater than +40°C up to +56°C
FDh	Greater than +56°C up to +72°C
FEh	Greater than +72°C up to +88°C
FFh	Greater than +88°C

The APC DAC is a 10-bit value. The APC LUT is an 8-bit LUT. The APC OFFSET LUT times 4 plus the APC LUT makes use of the entire 10-bit range.

Auxiliary Memory A0h Register Descriptions

Auxiliary Memory A0h, Register 00h–7Fh: EEPROM

FACTORY DEFAULT	00h
READ ACCESS	All
WRITE ACCESS	PW2 or (PW1 and WAUXA) or (WAUXAU)
MEMORY TYPE	Nonvolatile (EE)

00h–7Fh	2 ⁷	2 ⁶	2 ⁵	2 ⁴	2 ³	2 ²	2 ¹	2 ⁰
	BIT 7							BIT 0

Accessible with the slave address A0h.

SFP Controller with Dual LDD Interface

Auxiliary Memory A0h, Register 80h–FFh: EEPROM

FACTORY DEFAULT	00h
READ ACCESS	All
WRITE ACCESS	PW2 or (PW1 and WAUXB) or (WAUXBU)
MEMORY TYPE	Nonvolatile (EE)

80h–FFh	27	26	25	24	23	22	21	20
	BIT 7							BIT 0

Accessible with the slave address A0h.

Applications Information

Power-Supply Decoupling

To achieve best results, it is recommended that the power supply is decoupled with a 0.01 μ F or a 0.1 μ F capacitor. Use high-quality, ceramic, surface-mount capacitors, and mount the capacitors as close as possible to the VCC and GND pins to minimize lead inductance.

SDA and SCL Pullup Resistors

SDA is an open-collector output on the DS1876 that requires a pullup resistor to realize high logic levels. A master using either an open-collector output with a pullup resistor or a push-pull output driver can be used for SCL. Pullup resistor values should be chosen to ensure that the rise and fall times listed in the *I²C AC Electrical Characteristics* table are within specification.

Package Information

For the latest package outline information and land patterns, go to www.maximintegrated.com/packages. Note that a “+”, “#”, or “-” in the package code indicates RoHS status only. Package drawings may show a different suffix character, but the drawing pertains to the package regardless of RoHS status.



PACKAGE TYPE	PACKAGE CODE	DOCUMENT NO.
28 TQFN-EP	T2855+6	21-0140



Maxim Integrated cannot assume responsibility for use of any circuitry other than circuitry entirely embodied in a Maxim Integrated product. No circuit patent licenses are implied. Maxim Integrated reserves the right to change the circuitry and specifications without notice at any time. The parametric values (min and max limits) shown in the Electrical Characteristics table are guaranteed. Other parametric values quoted in this data sheet are provided for guidance.

Looking for pricing, stock, or lifecycle information?

Click below to explore more details on WIN SOURCE:

-  [View DS1876T+T&R on WIN SOURCE](#)
-  [Maxim Integrated Information](#)

Optimize Your Supply Chain with WIN SOURCE Solutions

-  Global Sourcing Solution
-  Obsolete Management
-  Cost Control Management
-  Shortage Management
-  Alternative Solution
-  Excess Inventory Management