



**THE DATASHEET OF  
DS1836C-10+**



### FEATURES

- 5V or 3.3V power-on reset
- True 3V operation power switch
- Switches to battery at 3.8V (2.6V for 3.3V versions)
- Excellent for systems designed to operate with dual power supplies
- Asserts resets during power transients
- Maintains reset for 350ms after  $V_{CC}$  returns to an in-tolerance condition
- Reduces need for discrete components
- Precision temperature-compensated voltage reference and voltage sensor
- 8-pin DIP or space saving 8-pin SO surface mount available
- CMOS reset output for low current operation
- Operating temperature of  $-40^{\circ}\text{C}$  to  $+85^{\circ}\text{C}$
- Perfect for PIC microprocessor applications

### PIN ASSIGNMENT

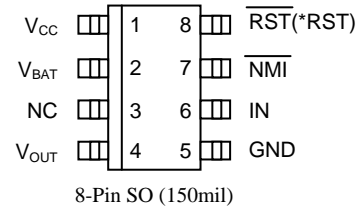
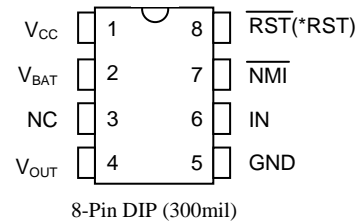

DS1836A/C (\*DS1836B/D)

### PIN DESCRIPTION

$V_{CC}$	- Power Supply Input
$V_{BAT}$	- Battery Supply Input
NC	- No Connect
$V_{OUT}$	- Power Supply Output
GND	- Ground
IN	- Sense Input
$\overline{\text{NMI}}$	- Non-maskable Interrupt
$\overline{\text{RST}}$ (*RST)	- Reset Output

### DESCRIPTION

The DS1836 MicroManager performs three vital system functions. First, a precision temperature-compensated reference and comparator circuit monitor the status of the voltage on  $V_{CC}$  and when an out-of-tolerance condition is detected, an internal power-fail signal is generated that forces the reset active. If  $V_{CC}$  continues to degrade, it switches to the battery supply when  $V_{CC}$  drops below 3.8V (2.6V for 3.3V versions). When  $V_{CC}$  exceeds 3.9V (2.8V for 3.3V versions);  $V_{OUT}$  will again be supplied from  $V_{CC}$ . Reset will remain active for 350 ms after  $V_{CC}$  returns to an in-tolerance condition.

Lastly, the DS1836 supports a sense input that sends a non-maskable interrupt whenever the sense input drops below 1.25V.

## OPERATION

### Power Monitor

The DS1836 provides the functions of detecting out-of-tolerance conditions on a 3.3V or 5V power supply and warning a processor-based system of impending power failure. When  $V_{CC}$  is detected as out of tolerance the RST will be forced active. When  $V_{CC}$  returns to a valid state the RST will remain active for about 350ms and then return to an inactive state until the next  $V_{CC}$  out-of-tolerance condition.

On power-up reset is kept active for approximately 350ms after the power supply input has reached the selected tolerance. This allows the power supply and system power to stabilize before RST is released.

### Power Switch (DS1836A & B)

The DS1836 switches the  $V_{OUT}$  output between  $V_{CC}$  and  $V_{BAT}$ . On the initial power-up,  $V_{OUT}$  draws current from the  $V_{BAT}$  input until  $V_{CC}$  exceeds 3.9V. When  $V_{CC}$  exceeds 3.9V  $V_{OUT}$  switches from  $V_{BAT}$  to  $V_{CC}$  and will not switch back to  $V_{BAT}$  until  $V_{CC}$  drops below 3.8V. When  $V_{CC}$  is below 3.8V, power will be drawn from the supply with the highest voltage: either  $V_{CC}$  or  $V_{BAT}$ .

### Power Switch (DS1836C & D)

The DS1836 switches the  $V_{OUT}$  output between  $V_{CC}$  and  $V_{BAT}$ . On the initial power up,  $V_{OUT}$  draws current from the  $V_{BAT}$  input until  $V_{CC}$  exceeds 2.8V. When  $V_{CC}$  exceeds 2.8V  $V_{OUT}$  switches from  $V_{BAT}$  to  $V_{CC}$  and will not switch back to  $V_{BAT}$  until  $V_{CC}$  drops below 2.6V. When  $V_{CC}$  is below 2.6V, power will be drawn from the supply with the highest voltage either  $V_{CC}$  or  $V_{BAT}$ .

## BLOCK DIAGRAM Figure 1

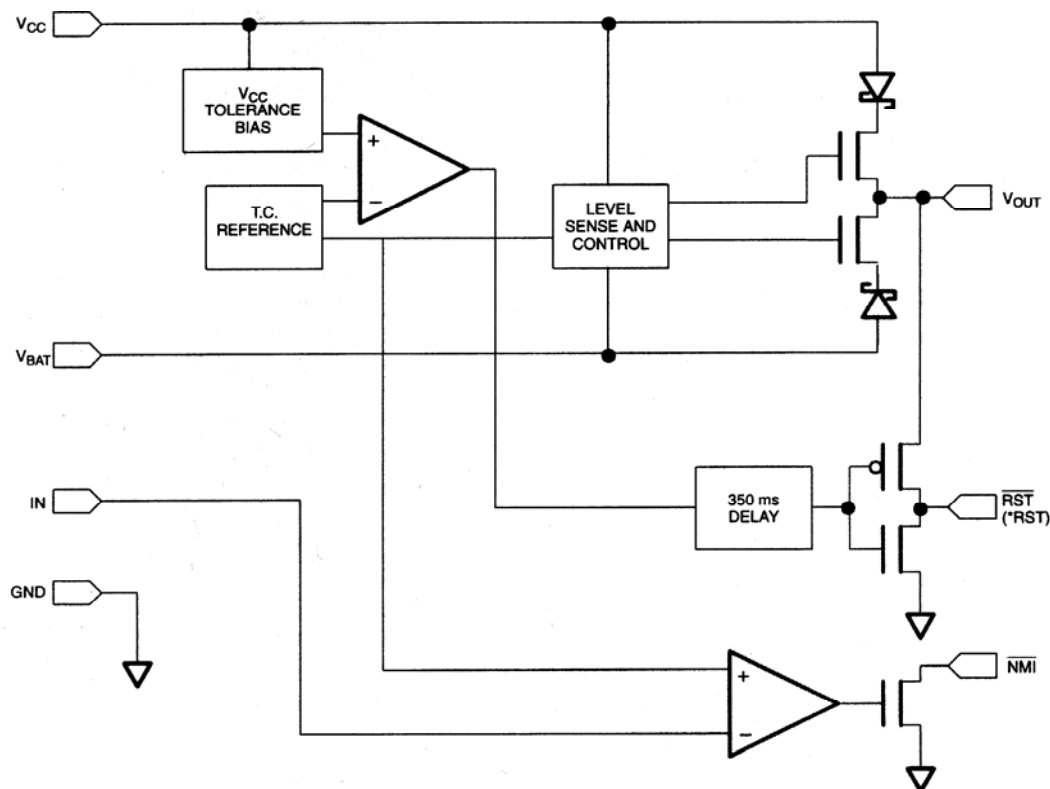

\* DS1836B and DS1836D

## Non-Maskable Interrupt

The DS1836 generates a non-maskable interrupt ( $\overline{\text{NMI}}$ ) for early warning of a power failure. A precision comparator monitors the voltage level at the IN pin relative to an on-chip reference generated by an internal band gap. The IN pin is a high impedance input allowing for a user-defined sense point. An external resistor voltage divider network (Figure 3) is used to interface with high voltage signals. This sense point may be derived from a regulated supply or from a higher DC voltage level closer to the main system power input. Since the IN trip point  $V_{\text{TP}}$  is 1.25V, the proper values for R1 and R2 can be determined by the equation as shown in Figure 3. Proper operation of the DS1836 requires that the maximum voltage at the IN pin be limited to the active supply ( $V_{\text{CC}}$  or  $V_{\text{BAT}}$ ). Therefore, the maximum allowable voltage at the supply being monitored ( $V_{\text{MAX}}$ ) can also be derived as shown in Figure 3. A simple approach to solving the equation is to select a value for R2 high enough to keep power consumption low and solve for R1. The flexibility of the IN input pin allows for detection of power loss at the earliest point in a power supply system, maximizing the amount of time for system shutdown between  $\overline{\text{NMI}}$  and  $\overline{\text{RST}}$  (or  $\overline{\text{RST}}$ ).

A pull-up resistor is required for proper operation of the  $\overline{\text{NMI}}$  open-drain output. A 10k $\Omega$  resistor would be a typical value for the pull-up resistor.

## TYPICAL APPLICATION Figure 2

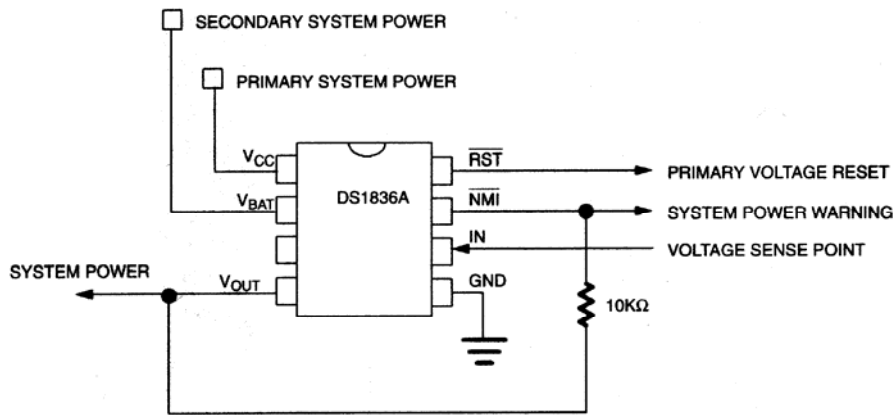

## NON-MASKABLE INTERRUPT CIRCUIT EXAMPLE Figure 3

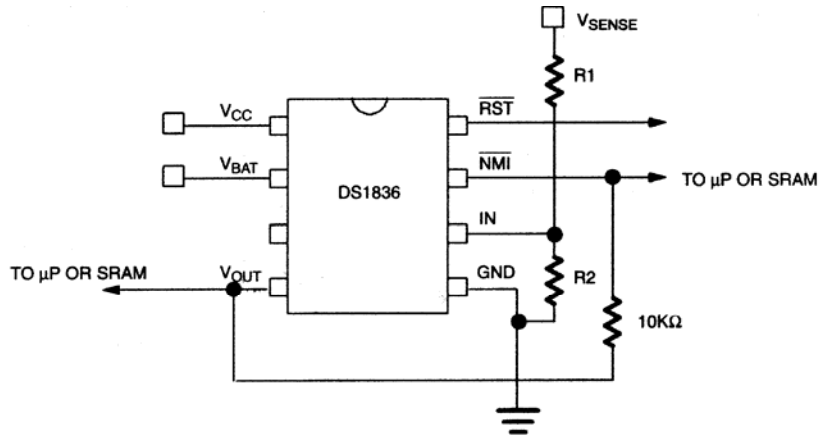

$$V_{\text{SENSE}} = \frac{R1 + R2}{R2} \times 1.25$$

Example:  $V_{\text{SENSE}} = 4.50\text{V}$  at the trip point  
 $100\text{k}\Omega = R2$

Therefore:  $4.5 = \frac{R1 + 100\text{k}}{100\text{k}} \times 1.25$        $R1 = 260\text{k}\Omega$

## TIMING DIAGRAM: NON-MASKABLE INTERRUPT Figure 4

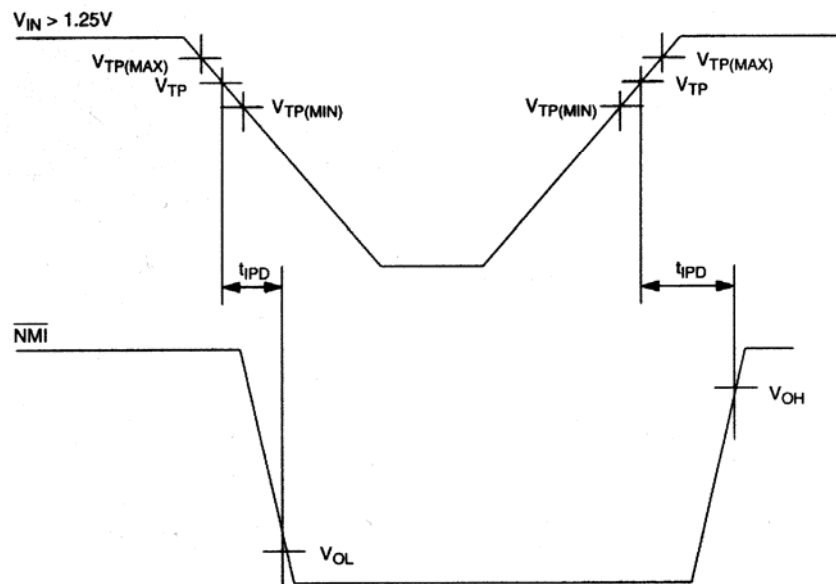

## OUTPUT VALID CONDITIONS

The DS1836 can maintain valid outputs as long as one input remains above 1.2V. However, the  $\overline{\text{RST}}$  outputs on the DS1836A (or C) use a push-pull output structure which can maintain a valid output below 1.2V on an input. To sink current below 1.2V a resistor can be connected from  $\overline{\text{RST}}$  to GND (see Figure 5). This arrangement will maintain a valid value on the  $\overline{\text{RST}}$  outputs even if all supply inputs are at 0V. During conditions when the  $\overline{\text{RST}}$  is in the inactive or high state this arrangement will draw current through the pull down resistor. A value of about 100 k $\Omega$  should be adequate to maintain a valid condition.

The DS1836  $\overline{\text{NMI}}$  output requires a pull-up resistor on the output to maintain a valid output. The value of the resistor is not critical in most cases but must be set low enough to pull the output to a high state. A common value used is 10k $\Omega$ s (see Figure 3).

### APPLICATION DIAGRAM:

#### $\overline{\text{RST}}$ VALID TO 0V $V_{\text{CC}}$ ON THE DS1836A OR DS1836C Figure 5

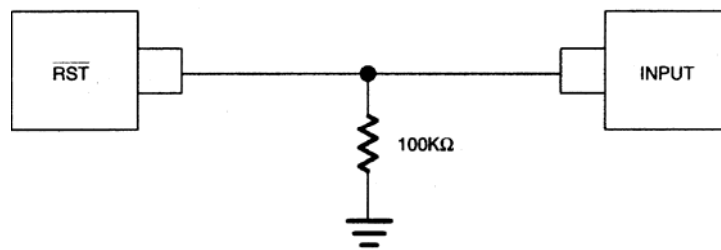

### TIMING DIAGRAM: POWER-UP Figure 6

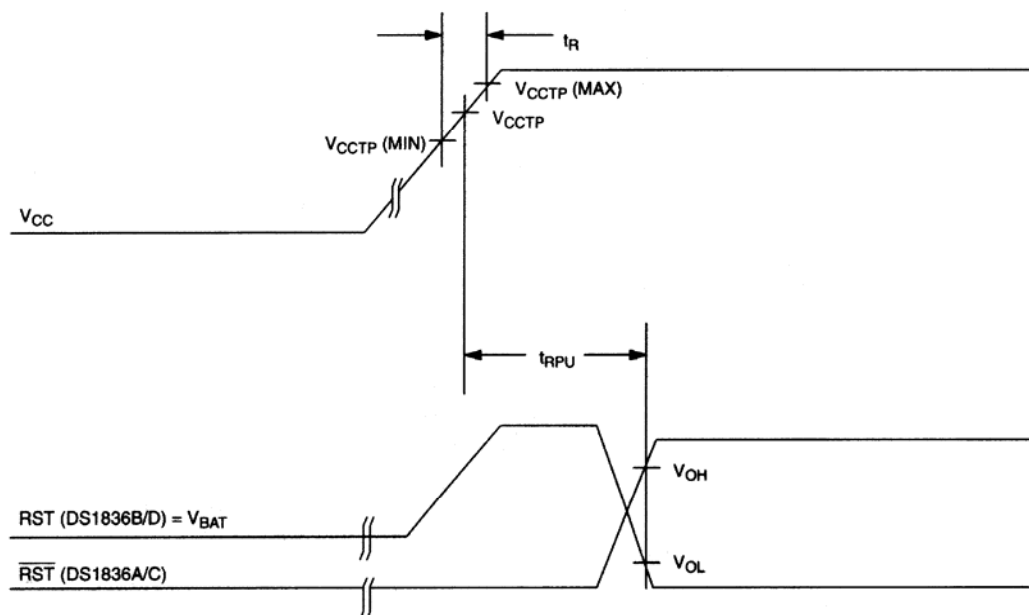

## TIMING DIAGRAM: POWER-DOWN Figure 7

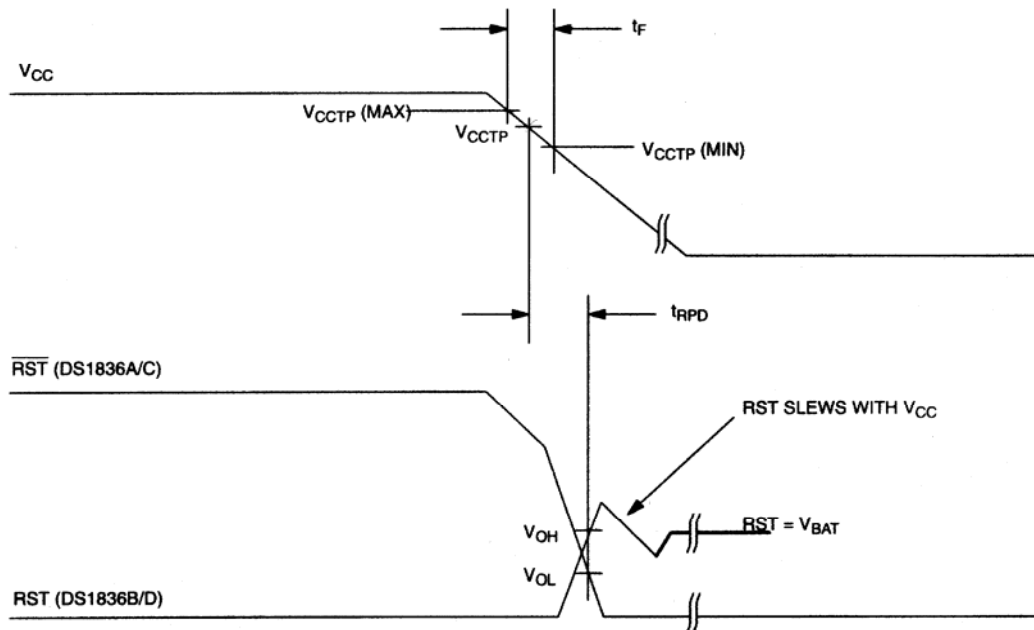

## TIMING DIAGRAM: POWER SWITCH Figure 8

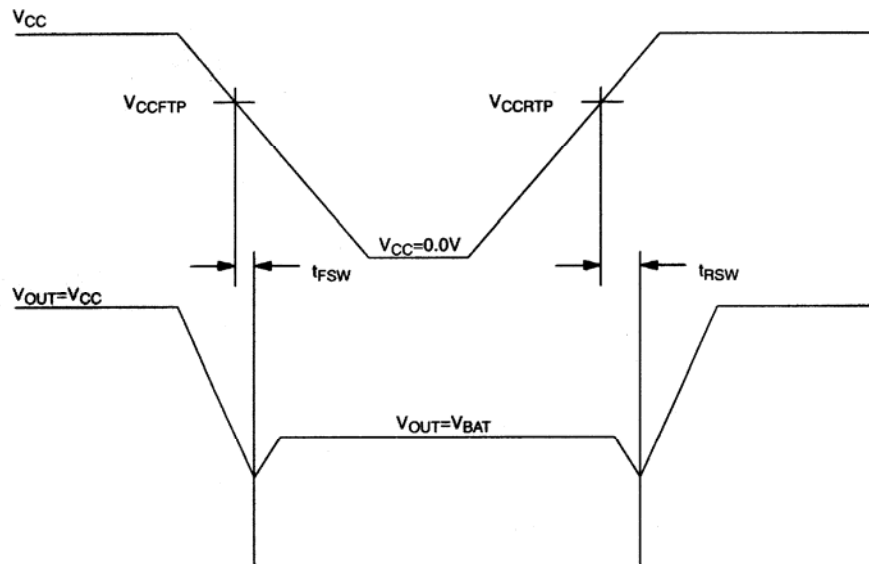

**ABSOLUTE MAXIMUM RATINGS\***

Voltage on $V_{CC}$ or $V_{BAT}$ Pin Relative to Ground	-0.5V to +7.0V
Voltage on any I/O Pin Relative to Ground**	-0.5V to $V_{OUT} + 0.5V$
Operating Temperature Range	-40°C to +85°C
Storage Temperature Range	-55°C to +125°C
Soldering Temperature	260°C for 10 seconds

\* This is a stress rating only and functional operation of the device at these or any other conditions above those indicated in the operation sections of this specification is not implied. Exposure to absolute maximum rating conditions for extended periods of time may affect reliability.

\*\*The voltage input on IN can exceed  $V_{CC}/V_{BAT}$  if the input current is less than 10mA.

**RECOMMENDED DC OPERATING CONDITIONS**

(-40°C to +85°C)

PARAMETER	SYMBOL	MIN	TYP	MAX	UNITS	NOTES
Supply Voltage	$V_{CC}$	1.2		5.5	V	1
Secondary Supply Voltage	$V_{BAT}$	1.2		5.5	V	1

**DC ELECTRICAL CHARACTERISTICS** (-40°C to +85°C;  $V_{CC} = 1.2V$  to  $5.5V$ )

PARAMETER	SYMBOL	MIN	TYP	MAX	UNITS	NOTES
Output Voltage @ -500 $\mu$ A	$V_{OH}$	$V_{CC}$ -0.5	$V_{CC}$ -0.1		V	1
Input Leakage	$I_{IL}$	-1.0		+1.0	$\mu$ A	2
Output Current @ 2.4V	$I_{OH}$		350		$\mu$ A	3
Output Current @ 0.4V	$I_{OL}$	+10			mA	3
Operating Current @ * 5.5 $V_{IN}$	$I_{CC}$		35	55	$\mu$ A	4
Operating Current @ * 3.6 $V_{IN}$	$I_{CC}$		30	50	$\mu$ A	5
Supply Output Current	$I_{CC01}$			100	mA	6
Supply Output Current	$I_{CC02}$			100	mA	7
Supply Output Voltage ( $V_{CC}$ )	$V_{OUT}$	$V_{CC}$ -0.5	$V_{CC}$ -0.3		V	1, 8
Supply Output Voltage ( $V_{BAT}$ )	$V_{OUT}$	$V_{BAT}$ -0.5	$V_{BAT}$ -0.3		V	1, 9
RST $V_{CC}$ Trip Point DS1836A(or B)-05	$V_{CCTP}$	4.50	4.63	4.75	V	1
RST $V_{CC}$ Trip Point DS1836A(or B)-10	$V_{CCTP}$	4.25	4.37	4.50	V	1
RST $V_{CC}$ Trip Point DS1836C(or D)-10	$V_{CCTP}$	2.80	2.88	2.97	V	1
RST $V_{CC}$ Trip Point DS1836C(or D)-20	$V_{CCTP}$	2.67	2.72	2.80	V	1
Power Supply Trip Points ( $V_{CC}$ to $V_{BAT}$ ) DS1836 C or D	$V_{CCFTP}$	2.60	2.65	2.70	V	1, 10
Power Supply Trip Points ( $V_{BAT}$ to $V_{CC}$ ) DS1836 C or D	$V_{CCRTP}$	2.70	2.75	2.80	V	1, 10
$V_{BAT}$ Leakage Current	$I_{CC03}$			0.10	$\mu$ A	11
Power Supply Trip Points ( $V_{CC}$ to $V_{BAT}$ ) DS1836 A or B	$V_{CCFTP}$	3.80	3.85	3.9	V	1, 10
Power Supply Trip Points ( $V_{BAT}$ to $V_{CC}$ ) DS1836 A or B	$V_{CCRTP}$	3.90	3.95	4.0	V	1, 10
IN Input Trip Point	$V_{TP}$	1.15	1.25	1.35	V	1
Output Capacitance	$C_{OUT}$			10	pF	

**AC ELECTRICAL CHARACTERISTICS** (-40°C to +85°C;  $V_{CC} = 1.2V$  to  $5.5V$ )

PARAMETER	SYMBOL	MIN	TYP	MAX	UNITS	NOTES
$V_{TP}$ to $\overline{NMI}$ Delay	$t_{IPD}$			1	$\mu s$	
Reset Active Time	$t_{RST}$	200	350	500	ms	
$V_{CC}$ Slew Rate ( $V_{INTP(MIN)}$ to $V_{INTP(MAX)}$ )	$t_R$	0			ns	
$V_{CC}$ Detect to $\overline{RST}$	$t_{RPU}$	200	350	500	ms	12
$V_{CC}$ Slew Rate ( $V_{INTP(MAX)}$ to $V_{INTP(MIN)}$ )	$t_F$	300			$\mu s$	
$V_{CC}$ Detect to $\overline{RST}$	$t_{RPD}$		2	10	$\mu s$	
$V_{CC}$ to $V_{BAT}$ ( $V_{CC}$ falling through 2.6V)	$t_{FSW}$		1		$\mu s$	
$V_{BAT}$ to $V_{CC}$ ( $V_{CC}$ rising through 2.8V)	$t_{RSW}$		1		$\mu s$	

**NOTES:**

- 1) All voltages are referenced to ground.
- 2) Measured with outputs open and inputs at  $V_{CC}$  or GND.
- 3) Measured with outputs open and  $V_{CC}$  or  $V_{BAT} < 2.7V$ .
- 4) Measured with outputs open and both  $V_{CC}$  and  $V_{BAT} < 5.5V$ .
- 5) Measured with outputs open and both  $V_{CC}$  and  $V_{BAT} < 3.6V$ .
- 6)  $V_{OUT} = V_{CC} - 0.3V$ .
- 7)  $V_{OUT} = V_{BAT} - 0.3V$ .
- 8)  $V_{CC} < 2.7V$ .
- 9)  $V_{BAT} < 2.0V$  and  $V_{CC} < 1.9V$ .
- 10)  $V_{CCFTP}$  is offset by approximately 0.1V from  $V_{CC RTP}$ .
- 11)  $V_{BAT}$  in the off state and  $V_{BAT} < V_{CC}$  ( $V_{BAT} > V_{CC}$  and  $V_{BAT}$  in the off state 1.5 $\mu A$  maximum).
- 12)  $t_R = 5\mu s$  with one supply  $< 2.5V$ .

**REVISION HISTORY**

Pages changed at Rev 1: 1, 9, 10

## Looking for pricing, stock, or lifecycle information?

Click below to explore more details on WIN SOURCE:

 [View DS1836C-10+](#) on WIN SOURCE

 [Maxim Integrated](#) Information

## Optimize Your Supply Chain with WIN SOURCE Solutions

-  Global Sourcing Solution
-  Obsolete Management
-  Cost Control Management
-  Shortage Management
-  Alternative Solution
-  Excess Inventory Management