



**THE DATASHEET OF  
DS1616K-000**



### FEATURES

- Measures four channels of data:
  - Integrated 8-bit temperature sensor
  - Integrated 8-bit analog-to-digital converter (ADC) with a three-input mux
- Digital thermometer measures temperature -40°C to +85°C in +0.5°C increments with ±2°C accuracy
- Real-time clock/calendar (RTC) in BCD format counts seconds, minutes, hours, date, month, day of the week, and year with leap-year compensation; fully Y2K-compliant
- Automatically wakes up and measures temperature and/or ADC data at user-programmable intervals from 1 to 255 minutes
- 2048-byte datalog memory
- Records long-term temperature histogram in 63 bins with +2.0°C resolution
- Records long-term ADC data histogram in 64 bins with 4-bit resolution/bin (32 mV/bin) for ADC Channel 1
- Programmable temperature-high and -low alarm trip points
- Programmable ADC data-high and -low alarm trip points
- Records time stamp and duration when temperature or ADC Channel 1 Data leaves the interval specified by the trip points
- Two serial interface options:
  - 3-wire synchronous serial interface
  - Asynchronous serial interface compatible with standard UARTs
- Memory partitioned into 32-byte pages for packetizing data
- On-chip 16-bit CRC generator to safeguard data read operations in asynchronous communications mode
- Unique, factory lasered 64-bit serial number

### PIN ASSIGNMENT (Top View)

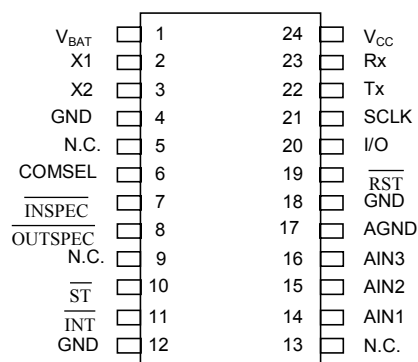

DS1616 24 DIP (600mil)

DS1616S 24 SO (300mil)

### Package Dimension Information

<http://www.maxim-ic.com/TechSupport/DallasPackInfo.htm>

### PIN DESCRIPTION

V <sub>BAT</sub>	- Battery Supply
X1	- Crystal Input
X2	- Crystal Output
AIN <sub>x</sub>	- Analog in
INSPEC	- In-Specification Output
OUTSPEC	- Out-of-Specification Output
INT	- Interrupt Output
GND	- Digital Ground
AGND	- Analog Ground
ST	- Start/Status Input
RST	- 3-Wire Reset Input
I/O	- 3-Wire Input/Output
SCLK	- 3-Wire Clock Input
Tx	- Transmit Output
Rx	- Receive Input
COMSEL	- Communication Select
V <sub>CC</sub>	- +5V Supply

## ORDERING INFORMATION

PART	PIN-PACKAGE	TEMP RANGE
DS1616	24 DIP	-40°C to +85°C
DS1616S	24 SO	0°C to +70°C

## DESCRIPTION

The DS1616 is an integrated temperature/data recorder. It combines a real-time clock (RTC), temperature sensor, and a three input muxed 8-bit Analog-to-Digital Converter (ADC). Data logging is supported for all four data channels and the histogram functionality is supported for the temperature sensor and ADC Channel 1 only. A programmable sample rate feature makes the device ideal for applications requiring datalogging over short or long time frames.

The RTC provides seconds, minutes, hours, day, date, month, and year information with leap year compensation, Year 2000 compliance, and also provides an alarm interrupt. Temperature measurement is provided via integrated thermal technology which can measure temperatures from -40°C to +85°C in 0.5°C increments. An integrated three input muxed 8-bit ADC allows the device to record data from other types of sensors.

The datalog function samples data at a user-defined sample rate and writes the data to the Datalog memory. A total of 2048 bytes of data may be recorded. If only one data channel is selected, a total of 2048 samples can be recorded for that channel. If two channels are enabled, each channel can record 1024 samples. If three or four channels are enabled, each channel can record 512 samples. In the case of only three channels enabled, the location corresponding to the disabled channel will be 0 to allow the roll-over function to work smoothly.

Histogram functionality is provided for the Thermal Sensor and ADC Channel 1, and is implemented by sampling the data and then incrementing the count value in a data bin associated with that value. The DS1616 provides 63 2-byte data bins in 2°C increments for the temperature channel and 64 2-byte data bins in 4-bit resolution steps (32mV/bin) for the ADC Data Channel 1. The sampling rate can be programmed at intervals ranging from once per minute to once every 255 minutes.

The DS1616 provides programmable high- and low-temperature alarm trip points that allow the device to monitor whether the temperature stays within desired limits. Likewise, high- and low- trip points can be programmed for the ADC data. The device can drive an interrupt or status pin if the ADC data falls outside of the programmable limits. The Temperature Sensor and Channel 1 of the ADC can also have any event that falls outside of the programmed limits recorded with a time and date stamp and the duration of the out-of-limits condition for additional analysis in the Alarm Memory. The DS1616 can be programmed to begin sampling data via a pushbutton input or via a command sent over the serial interface by a host machine.

A 64-bit serial number is available for unique product identification and tracking.

## OVERVIEW

The block diagram in Figure 1 shows the relationship between the major control and memory sections of the DS1616. The device has six major data components: 1) RTC and control blocks, 2) 32-byte User NV RAM with 64-bit lasered serial number, 3) 96 bytes of alarm event/duration memory, 4) 128 bytes of temperature histogram RAM, 5) 128 bytes of ADC Channel 1 data histogram RAM, and 6) 2048 bytes of datalog memory. All memory is arranged in a single linear address space.

## DS1616 Block Diagram Figure 1

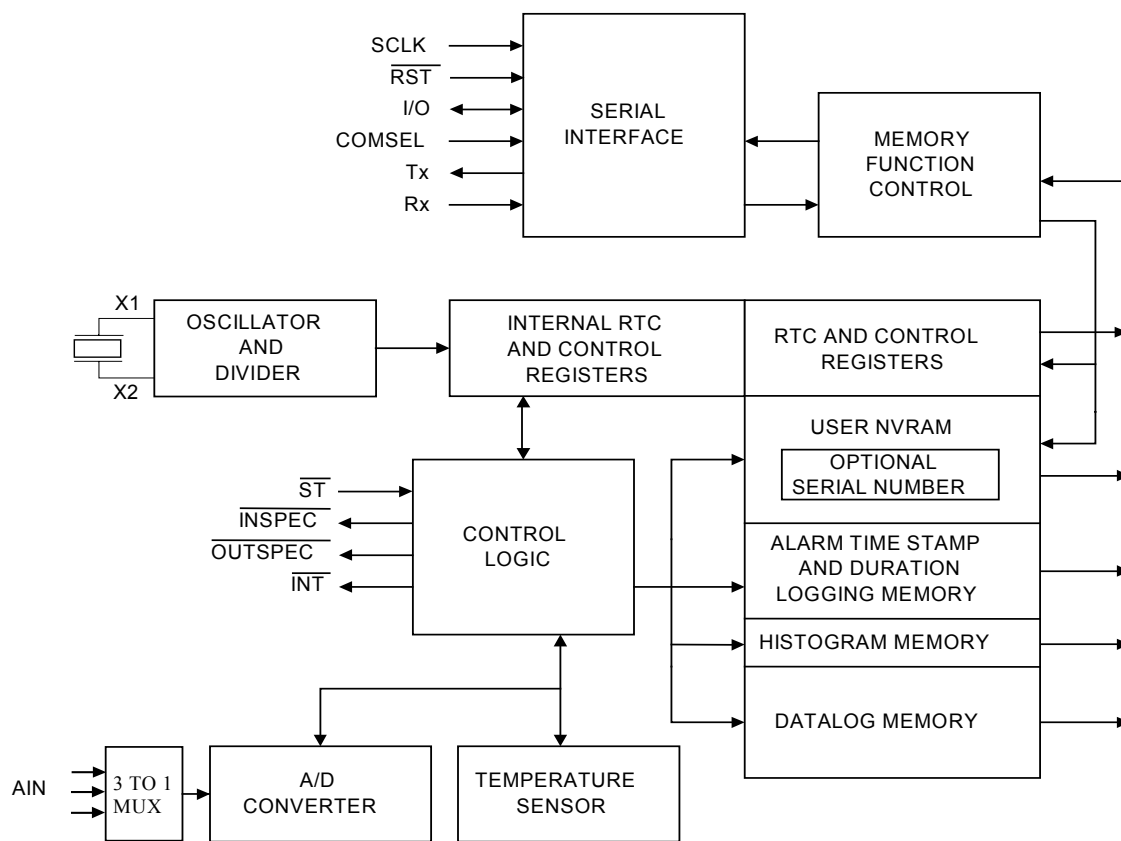

## SIGNAL DESCRIPTIONS

The following paragraphs describe the function of each pin.

**V<sub>CC</sub>** - V<sub>CC</sub> is a +5-volt input supply. Communication with the DS1616 can take place only when V<sub>CC</sub> is connected to a +5-volt supply.

**V<sub>bat</sub>** - Battery input for standard lithium cell or other energy source. All functions of the DS1616 with the exception of the serial interface circuitry are powered by V<sub>bat</sub> when V<sub>CC</sub> < V<sub>bat</sub>. All functions are powered by V<sub>CC</sub> when V<sub>CC</sub> > V<sub>bat</sub>. If a battery or other energy source is not used, V<sub>bat</sub> should be connected directly to GND.

**GND** - GND connections are not internally connected, so all GND connections must be connected directly to ground.

**AGND** - Analog ground should be connected directly to digital ground externally to eliminate ground noise and potential differences.

**COMSEL (Communication Select Input)** - This pin determines whether serial communication is asynchronous or synchronous. When pulled high to V<sub>CC</sub>, communication is synchronous and will take place via the SCLK, I/O, and RST pins. When COMSEL is tied to ground, asynchronous communication utilizing the TX and RX pins is selected. If this pin is floated, the DS1616 will operate in the asynchronous communications mode since the COMSEL pin has a weak internal pulldown resistor.

**Tx (Transmit Output)** - Transmit output of the asynchronous serial interface. Tx is tri-stated whenever  $V_{CC} < V_{bat}$ .

**Rx (Receive Input)** - Receive input of the asynchronous serial interface.

**SCLK (3-Wire Serial Clock Input)** - The SCLK pin is the serial clock input for the 3-wire synchronous communications channel.

**I/O (3-Wire Input/Output)** - The I/O pin is the data Input/Output signal for the 3-wire synchronous communications channel.

**$\overline{\text{RST}}$  (3-Wire Reset Input)** - The  $\overline{\text{RST}}$  pin is the communications reset pin for the 3-wire synchronous communications channel.

**$\overline{\text{INT}}$  (Interrupt Output)** - The  $\overline{\text{INT}}$  pin is an open drain active low output that can be connected to an interrupt input of a microprocessor. The  $\overline{\text{INT}}$  output remains low as long as the status bit causing the interrupt is present and the corresponding interrupt-enable bit is set.

**$\overline{\text{INSPEC}}$  (Open Drain In-Specification Output)** - This pin, in conjunction with the  $\overline{\text{OUTSPEC}}$  pin, is used to signal the status of the operation and data of the DS1616.

**$\overline{\text{OUTSPEC}}$  (Open Drain Out-of-Specification Output)** - This pin, in conjunction with the  $\overline{\text{INSPEC}}$  pin, is used to signal the status of the operation and data of the DS1616.

**$\overline{\text{ST}}$  (Start/Status Button Input)** - The  $\overline{\text{ST}}$  pin provides two functions. First, when enabled as the datalog start source (SE bit in Control 1 register is a logic 1), the  $\overline{\text{ST}}$  pin is used to instruct the DS1616 to begin recording data based on the programmed start delay and data sample rate. The  $\overline{\text{ST}}$  pin must be held low for at least 0.5 seconds for a datalog mission to begin.

Secondly, the  $\overline{\text{ST}}$  pin can be used to poll the status of the recorded data. After datalogging has begun, the  $\overline{\text{ST}}$  pin instructs the DS1616 to report the status of the recorded data via the  $\overline{\text{INSPEC}}$  and  $\overline{\text{OUTSPEC}}$  pins.

**AIN1, AIN2, AIN3 (Analog Inputs)** - The AINx pins are the muxed inputs to the ADC.

**X1, X2** - Connections for a standard 32.768 kHz quartz crystal, Daiwa part number DT-26S or equivalent. For greatest accuracy, the DS1616 must be used with a crystal that has a specified load capacitance of 6 pF. There is no need for external capacitors or resistors. Note: X1 and X2 are very high impedance nodes. It is recommended that they and the crystal be guard-ringed with ground and that high frequency signals be kept away from the crystal area. For more information on crystal selection and crystal layout considerations, refer to *Application Note 58: Crystal Considerations with Dallas Real-Time Clocks*.

**N.C. (No Connect)** - These pins should be left unconnected or tied to ground.

## MEMORY

The memory map in Figure 2a shows the general organization of the DS1616. As can be seen in the figure, the device is segmented into 32-byte pages. Pages 0 and 1 contain the RTC and Control registers (see Figure 2b for more detail). The User NV RAM resides in page 2. Pages 17 to 19 are assigned to storing the alarm time stamps and durations and pages 64 to 71 are reserved for histogram memory. The data logging memory covers pages 128 to 191. Memory pages 3 to 16, 20 to 63, 68 to 127, and 192 and up are reserved for future extensions.

The end user can write only to the RTC and Control registers and the User NV RAM. The rest of the memory map is read-only from the end user's perspective.

### DS1616 MEMORY MAP Figure 2a

Address	Register definition	Page(s)
0000H 003FH	RTC and Control Registers	0 - 1
0040H 005FH	User NV RAM	2
0060H 0217H	(Reserved for Future Extensions)	3 – 16*
0218H 021FH	Serial Number	16**
0220H 027FH	Alarm Time Stamps and Durations	17 – 19
0280H 07FFH	(Reserved for Future Extensions)	20 – 63
0800H 087FH	Temperature Histogram (63 Bins of 2 Bytes Each)	64 – 67
0880H 08FFH	ADC Channel 1 Data Histogram (64 Bins of 2 Bytes Each)	68 – 71
0900H 0FFFH	(Reserved for Future Extensions)	72 – 127
1000H 17FFH	Datalog Memory (64 pages)	128 – 191
1800H and higher	(Reserved for Future Extensions)	192 +

\* First 8 bytes

\*\* Last 8 bytes

## DS1616 RTC AND CONTROL PAGE Figure 2b

Addr.	Bit 7	Bit 6	Bit 5	Bit 4	Bit 3	Bit 2	Bit 1	Bit 0	Function
00	0	10 Seconds			Single Seconds			Real-Time Clock Registers	
01	0	10 Minutes			Single Minutes				
02	0	12/24	10 h	10 h	Single Hours				
			A/P						
03	0	0	0	0	Day Of Week				
04	0	0	10 Date		Single Date				
05	Y2K	0	0	10 m.	Single Months				
06	10 Years			Single Years					
07	MS	10 Seconds Alarm			Single Seconds Alarm			Real-Time Clock Alarm	
08	MM	10 Minutes Alarm			Single Minutes Alarm				
09	MH	12/24	10 ha.	10 h. alm.	Single Hours Alarm				
			A/P						
0A	MD	0	0	0	0	Day Of Week Alarm			
0B	Low Temperature Threshold								Temperature Alarm
0C	High Temperature Threshold								
0D	Number Of Minutes Between Temperature Conversions								Sample Rate
0E	EOSC	CLR	0	SE	RO	TLIE	THIE	AIE	Control 1
0F	(reads 00h)								Reserved
10	(reads 00h)								Reserved
11	Current Temperature								Temperature
12	Start Delay Register (LSB)								Start Delay
13	Start Delay Register (MSB)								Start Delay
14	DR	MEM CLR	MIP	SIP	LOBAT	TLF	THF	ALMF	Status 1
15	Minutes								Start Time Stamp
16	Hours								
17	Date								
18	Y2K	Month							
19	Year								
1A	Low Byte								Current Samples Counter
1B	Medium Byte								
1C	High Byte								
1D	Low Byte								Total Samples Counter
1E	Medium Byte								
1F	High Byte								
20	Current ADC Channel 1 Data								Sensor Input 1
21	Current ADC Channel 2 Data								Sensor Input 2
22	Current ADC Channel 3 Data								Sensor Input 3
23	Low ADC Channel 1 Data Threshold								ADC Data
24	High ADC Channel 1 Data Threshold								Ch1 Alarm
25	Low ADC Channel 2 Data Threshold								ADC Data
26	High ADC Channel 2 Data Threshold								Ch2 Alarm
27	Low ADC Channel 3 Data Threshold								ADC Data
28	High ADC Channel 3 Data Threshold								Ch3 Alarm
29	0	CS0 (Temp)	CS1 (ADC 1)	CS2 (ADC 2)	CS3 (ADC 3)	ALIE	AHIE	0	Control 2
2A	0	ALF1	AHF1	ALF2	AHF2	ALF3	AHF3	0	Status 2
2B-3F	(reads 00h)								Reserved

## DS1616 ALARM TIME STAMPS AND DURATIONS FOR THE THERMAL SENSOR AND ADC CHANNEL 1 Figure 2c

Sample Counter Address (Low, Medium, High Bytes)	Duration Address	Register
220, 221, 222	223	T1 Low
224, 225, 226	227	T2 Low
228, 229, 22A	22B	T3 Low
22C, 22D, 22E	22F	T4 Low
230, 231, 232	233	T5 Low
234, 235, 236	237	T6 Low
238, 239, 23A	23B	T1 High
23C, 23D, 23E	23F	T2 High
240, 241, 242	243	T3 High
244, 245, 246	247	T4 High
248, 249, 24A	24B	T5 High
24C, 24D, 24E	24F	T6 High
250, 251, 252	253	D1 Low
254, 255, 256	257	D2 Low
258, 259, 25A	25B	D3 Low
25C, 25D, 25E	25F	D4 Low
260, 261, 262	263	D5 Low
264, 265, 266	267	D6 Low
268, 269, 26A	26B	D1 High
26C, 26D, 26E	26F	D2 High
270, 271, 272	273	D3 High
274, 275, 276	277	D4 High
278, 279, 27A	27B	D6 High
27C, 27D, 27E	27F	D6 High

## DS1616 TEMPERATURE HISTOGRAM DATA BINS Figure 2d

Address (Low – High Byte)	Register
800 – 801	-40, -39.5, -39, -38.5°C Data Bin
802 – 803	-38, -37.5, -37, -36.5°C Data Bin
804 ↓ 87B	↓
87C – 87D	84, 84.5, 85°C Data Bin

## DS1616 ADC DATA HISTOGRAM DATA BINS Figure 2e

Address (Low – High Byte)	Register
880 – 881	Channel 1 Code 00, 01, 02, 03h Data Bin
882 – 883	Channel 1 Code 04, 05, 06, 07h Data Bin
884 ↓ 8FD	↓
8FE – 8FF	Channel 1 Code FC, FD, FE, FFh Data Bin

## THERMAL SENSOR

The key to temperature monitoring in the DS1616 is an integrated thermal sensor. The thermal sensor can measure temperature from -40°C to +85°C in 0.5°C increments (Fahrenheit equivalent is -40°F to +183.2°F in 1.8°F increments). The thermal sensor provides an accuracy of  $\pm 2^\circ\text{C}$ .

The thermal sensor is enabled by setting the CS0 bit of the Control 2 register to a logic 1. If the CS0 bit is a logic 0, the thermal sensor will not be activated during a datalogging mission or for an individual Read Data command. If CS0 = 0, the value in the Current Temperature register will be 1111111b.

The format of temperature data is defined such that the temperature value is maintained in a single byte of data. Table 1 illustrates the format of the temperature data byte format. The values of T[7..0] range from 0000000b (for -40°C) to 11111010b (for +85°C). Each increment in the value of T[7..0] represents an increase in temperature of 0.5°C. The following formula can be used to translate the temperature data byte value into degrees Celsius:  $^{\circ}\text{C} = 0.5(\text{T}[7..0]) - 40$

### TEMPERATURE DATA BYTE FORMAT Table 1

MSb						LSb	
T7	T6	T5	T4	T3	T2	T1	T0

When a datalog mission has been initiated and the thermal sensor is enabled (CS0=1), the DS1616 provides temperature recording at regular intervals. However, the device also allows for immediate temperature sensing upon a user's command when the device is not currently on a datalog mission and the thermal sensor is enabled (CS0=1). This is accomplished by issuing the Read Data command to the DS1616 over the serial interface.

The most recently recorded temperature value is written to the Current Temperature register, regardless of whether that value was recorded from a datalog mission or from the issuance of the Read Data command. The status of the contents of this register is provided by the Data Ready (DR) bit in the Status 1 register. If DR is a logic 1, the data is valid. If DR is a logic 0, the data may not be reliable. If CS0 in the Control 2 register is a 0 such that the thermal sensor is disabled, the value in the Current Temperature register will be 1111111b. The Read Data command will not output this byte of data.

During a datalog mission, the DR bit is cleared to a logic 0 when a temperature conversion has been initiated and is set to a logic 1 upon the completion of the conversion. Likewise, the DR bit is cleared immediately after the Read Data command is issued and is set to a logic 1 upon the completion of the conversion. The Read Data command will only read the values in the current temperature/ADC data that have been enabled by the CSx[03] bits in the control 2 register.

### ANALOG-TO-DIGITAL CONVERTER (ADC)

The DS1616 contains an integrated 8-bit ADC with a 3 to 1 input mux to allow multiple sensors to be monitored. An on-chip voltage reference is also provided by an integrated band gap circuit (2.04V  $\pm$ 3%). The ADC input voltage must not be greater than the battery voltage.

An analog-to-digital conversion is the process of assigning a digital value to an analog input voltage. This code represents the input value as a fraction of the full scale voltage (FSV) range. Thus the FSV range is then divided by the ADC into 256 codes (8 bits). The FSV range is bounded by an upper limit equal to the reference voltage and the lower limit, which is ground. The 2.04V (typical) bandgap reference provides a resolution of 8mV between codes.

An input voltage equal to the reference voltage converts to FFh while an input voltage equal to ground converts to 00h. The relative linearity of the ADC is  $\pm 0.5$  LSB.

When a datalog mission has been initiated and one or more of the Analog Inputs are enabled (CS[1-3] = 1), the DS1616 provides data conversion and recording at regular intervals. However, the device also

allows for immediate data conversion upon a user's command when the device is not currently performing a conversion and one or more of the Analog Inputs are enabled ( $CS[1-3] = 1$ ). This is accomplished by issuing the Read Data command to the DS1616 over the serial interface.

The most recently recorded data value is written to the Current Data register that corresponds to the analog channel(s) that is(are) enabled, regardless of whether that value was recorded from a datalog mission or from the issuance of the Read Data command. The status of the contents of this register is provided by the Data Ready (DR) bit in the Status 1 register. If DR is a logic 1, the data is valid. If DR is a logic 0, the data may not be reliable. If a channel is not enabled,  $CS[1-3]$  is a logic 0, the contents of the corresponding Current Data register will be 00000000b and not outputted when a Read Data command is issued.

During a datalog mission, the DR bit is cleared to a logic 0 when a data conversion has been initiated and is set to a logic 1 upon the completion of the conversion. Likewise, the DR bit is cleared immediately after the Read Data command is issued and is set to a logic 1 upon the completion of the conversion.

## DATA LOGGING

When the DS1616 datalogging function is enabled, the device is said to be on a "datalog mission" until the datalogging is stopped.

During a datalog mission, temperature and/or ADC samples are successively written to the Datalog memory pages. These memory pages are located at addresses 1000h to 17FFh.

The end user can program the DS1616 to record data from all four data channels or just one channel. Channel selection is determined by the setting the Channel Select bits ( $CS_0$ ,  $CS_1$ ,  $CS_2$  and  $CS_3$ ) in the Control 2 register to the appropriate states. A 1 in the  $CS_x$  bit will enable the channel and allow the results to be reported, while a 0 will disable the channel, prevent its data from being recorded, prevent the data from being reported by the Read Data command, and set the contents of the memory location for the Current Data register corresponding to that channel to a constant value, all 1s for the thermal sensor or all 0s for the ADC channels.

When 3 or 4 data channels are selected, the first data sample is written to address location 1000h, the second is written to address location 1001h. The address is incremented with each additional data sample, with samples alternating between the enabled channels. The second sample is always measured immediately after the completion of the first measurement with the third and fourth samples following the second. The order of the sampling is the same as the order of the Channel Select registers.  $CS_0$  will be sampled first, if it is enabled, followed by  $CS_1$ ,  $CS_2$  and  $CS_3$  if they are enabled. Any disabled channels will be skipped. A total of 2048 registers have been reserved for datalog data, providing a total of 512 samples for each channel.

When three out of the four channels are enabled, a fourth byte of all 0s will be recorded in the Datalog Memory after the three bytes of data from the enabled channels in order to allow the data to rollover and remain in the correct positions.

When two data channels are selected, the first data sample is written to address location 1000h and the second is then written to address location 1001h. The address is incremented with each additional data sample, with samples alternating between the enabled channels.

The second sample is always measured immediately after the completion of the first measurement. A total of 2048 registers have been reserved for datalog data, providing a total of 1024 samples each channel.

If one data channel is selected, the entire datalog memory is dedicated to that one channel and therefore a total of 2048 samples can be recorded.

A datalog mission can be initiated via two different methods: by a host instruction over the serial interface or by a pushbutton input. When the SE bit in the Control 1 register is cleared to a logic 0, the start function of the  $\overline{ST}$  pin is disabled and writing any non-0 value to the Sample Rate register will start a mission. When the SE bit is set to a logic 1, the pushbutton method of starting a mission is enabled. Under this mode of operation, the DS1616 will begin a datalog mission when a non-0 value has been written to the Sample Rate register and the  $\overline{ST}$  pin has been held low for at least 0.5 seconds.

The sample rate during a datalog mission is equal to the value written to the Sample Rate register multiplied by one minute. Writing a 0 to the MIP bit in the Status 1 register completes the mission.

Upon initiation of datalog mission by either method, the DS1616 will do two things:

1. The  $\overline{INSPEC}$  and  $\overline{OUTSPEC}$  pins will generate four low pulses simultaneously.
2. The Mission-in-Progress (MIP) bit in the Status 1 register is set to a 1.

The time at which the first datalog sample is measured is dependent upon the value in the Start Delay registers. The two-byte Start Delay register provide a method for the end user to program a delay before sampling commences. The delay is roughly equal to the value in the Start Delay register times one minute. For example, if the Start Delay register contain a value of 10, then the device will begin recording data approximately ten minutes after it received either the pushbutton start signal or start instruction. The Start Delay register are located at addresses 0012h and 0013h, with register 0012h being the LSB and register 0013h being the MSB. The Start Delay register decrements every time the Seconds register rolls over from 59 to 00. When this Start Delay register contains a 00, the first datalog sample will be taken when the seconds register rolls over from 59 to 00.

The user has two options for dealing with the potential occurrence of a data overrun (i.e., more than 2048 total data samples). The first option is to enable the rollover feature of the DS1616. This is accomplished by setting the Rollover bit (bit 3 of the Control 1 register) to 1. When the Rollover feature is enabled, new data is written over previous data, starting with address 1000h. For example, if the Datalog memory has been completely filled (i.e., 2048 data samples have been recorded) the next data sample will be written to address location 1000h and the address pointer will be incremented with each successive data sample.

The second option for dealing with data overrun is to stop recording data after the datalog memory has been completely used. In other words, the DS1616 will stop recording data values after 2048 data samples. This feature is enabled by disabling the Rollover feature. (Bit 3 of the Control 1 Register) set to 0.

It should be noted that during a datalog mission, a time stamp for the first sample is recorded, but is not included for each subsequent sample. However, the time of acquisition for any data sample is easily determined by considering the start time, the sample rate, the value in the Current Sample Counter, and the address of the particular data sample in the datalog memory. If no rollover has occurred in the datalog memory, the sample time associated with any particular data point can be calculated by multiplying the address of the data by the sample rate and adding that to the stored start time value.

If the rollover feature has been enabled, the user can determine if rollover has occurred by reading the value in the Current Samples register. This register counts the total number of samples that have been acquired. If this value is greater than 07FFh (decimal 2047) then the user knows that rollover has

occurred. If rollover has occurred, the user needs to determine how many times rollover occurred in determining the sample time for any particular data sample.

As a safety measure, the DS1616 has been designed such that the end user cannot write to the Datalog Memory. This prevents the falsification of datalog data by writing values to datalog registers.

## DATA HISTOGRAM

While on a datalog mission, the DS1616 also records a histogram of the temperature and/or ADC Channel 1 data. The temperature histogram is provided by a series of 63 2-byte “data bins” that are located in the Temperature Histogram memory pages (addresses 0800h to 087Fh). Each bin consists of a 16-bit binary counter that is incremented each time an acquired temperature value falls into the range of the bin. The least significant byte of each bin is stored at the lower address. Bin 0 begins at memory address 0800h, bin 1 at 0802h, and so on up to 087Ch for bin 62. See Figure 2d for temperature histogram address map.

Likewise, the ADC Channel 1 Data histogram is provided by a series of 64 2-byte “data bins” that are located in the ADC Data Histogram memory pages (addresses 0880h to 08FFh). Each data bin represents four ADC codes (32mV/bin). For example, bin 0 counts the frequency of ADC codes from 00-03h. Bin 1 counts the frequency of ADC codes from 04-07h, and so on. See Figure 2e for ADC Data histogram address map.

After a temperature and/or ADC conversion is completed, the number of the bin to be updated is determined by dropping the two least significant bits of the binary data value. For example, bin 0 of the temperature histogram will be updated with every temperature reading from  $-40^{\circ}\text{C}$  to  $-38.5^{\circ}\text{C}$ . In the same way, bin 1 is associated with the range of  $-38^{\circ}\text{C}$  to  $-36.5^{\circ}\text{C}$ . Bin 62, finally, counts temperature values in the range of  $+84^{\circ}\text{C}$  to  $+85.0^{\circ}\text{C}$ . Since the device will not generate temperature values higher than  $85.0^{\circ}\text{C}$ , bin 62 covers only three temperature values. The memory for a potential 64<sup>th</sup> bin exists, but will always read 0s.

Since each data bin contains 2 bytes, a total of 65,535 samples can be accumulated. If more samples are measured, the data bin will remain at the maximum value. In other words, the data bin value will not roll-over in the event of an overrun.

## ALARM LOGGING

For some applications it may be essential to record exactly when a data sample exceeds a predefined tolerance band and for how long the violation remained. The Thermal Sensor (CS1) and ADC Channel 1 (CS2) are equipped with the alarm logging feature. The ADC Channels 2 & 3 do not have the logging feature, but they still have the alarm feature and the ability to trigger an interrupt. If an out of tolerance condition occurs on channels 2 or 3, the time and duration can be calculated from the Memory if the memory has not rolled over since the alarm.

A tolerance band is specified by means of the Temperature Alarm registers (addresses 000Bh and 000Ch) and the ADC Data Alarm [1-3] registers (addresses 0024h to 0029h). See figure 2b for more details on the memory mapping. One can set a high and a low threshold. As long as the data samples stay within the tolerance bands (i.e., are higher than the low threshold and lower than the high threshold), the DS1616 will not record any alarm.

If the temperature violates the temperature band, the DS1616 will generate an alarm and set either the Temperature-High Flag (THF) or the Temperature-Low Flag (TLF) in the Status 1 register (address 0014h). In addition, the device generates a time stamp of when the alarm occurred and records the

duration of the alarming condition. The  $\overline{\text{INT}}$  pin will be asserted by a high temperature alarm if the Temperature-High Interrupt Enable (THIE) is set and will be asserted by a low temperature alarm if the Temperature-Low Interrupt Enable (TLIE) is set.

Likewise, if ADC Channel 1 Data measurement violates the ADC Data band, either the ADC Data-High 1 or Data-Low 1 Flag (AHF1 or ALF1) will be set, a time stamp will be generated, and the duration of the violation will be recorded. The  $\overline{\text{INT}}$  pin will be asserted by a high-alarm if the ADC Data-High Interrupt Enable (AHIE) is set and will be asserted by a low-alarm if the ADC Data-Low Interrupt Enable (ALIE) is set.

The device stores a time stamp of a violating condition by copying contents of the 3-byte Current Samples Counter when the alarm occurred. The least significant byte is stored at the lower address. One address higher than a time stamp, the DS1616 maintains a 1-byte duration counter that stores the number of times the data was found to be beyond the threshold. If this counter has reached its limit after 255 consecutive data readings and the data has not yet returned to a level within the tolerance band, the device will issue another time stamp at the next higher address and open another counter to record the duration. If the data returns to normal before the counter has reached its limit, the duration counter of the particular time stamp will not increment any further. Should the data again cross this threshold, new time stamp will be recorded and its associated counter will increment with each data reading outside the tolerance band. This algorithm is implemented for the low- as well as for the high- thresholds.

Time stamps and durations for low-temperature violations are stored in the Registers 0220h to 0237h (24 bytes) and registers 0238h to 024Fh (24 bytes) are reserved for high-temperature violations. Registers 0250h to 0267h are reserved for low-ADC Channel 1 Data violations and registers 0268h to 027Fh are reserved for high-ADC Channel 1 Data violations.

This allocation allows the recording of 24 individual alarm events and periods (six each for high-temperature, low-temperature, high-ADC Channel 1 Data, and low-ADC Channel 1 Data violations). The date and time of each of these periods can be determined from the Start Time Stamp and the time sample rate. Figure 2c illustrates the Alarm Time Stamps and Durations registers.

## **$\overline{\text{INSPEC}}$ AND $\overline{\text{OUTSPEC}}$ PINS**

Two special output pins,  $\overline{\text{INSPEC}}$  and  $\overline{\text{OUTSPEC}}$ , are intended to output the status of the DS1616. More specifically, these pins can be used to control the illumination of LEDs. For example, the  $\overline{\text{INSPEC}}$  pin can be used to pulse a green LED and the  $\overline{\text{OUTSPEC}}$  pin can be used to pulse a red LED. When the end user starts a datalog mission or polls the device for information, one or both of these pins will be pulsed four times. Depending on the status of the device, both pins will be pulsed simultaneously or just one pin will be pulsed at a time. Each pulse is 62.5 ms in duration and will start every half second. See Figures 9 and 10 for further details.

The  $\overline{\text{INSPEC}}$  and  $\overline{\text{OUTSPEC}}$  pins are used to provide visual feedback to the end user in the following situations:

### 1. Datalog Mission Start

When a datalog mission is first initiated, the  $\overline{\text{INSPEC}}$  and  $\overline{\text{OUTSPEC}}$  pins will generate four low pulses simultaneously to give the end user a visual indication that a datalog mission has begun.

### 2. Request for Status of Data

Following a user request for the status of recorded data, the  $\overline{\text{INSPEC}}$  pin will generate four low pulses if the recorded data is within the user-defined limits (as set in the Threshold registers). If the recorded temperature data contains any readings that fall outside of these high- and low-temperature thresholds or if the recorded ADC data from any of the three ADC channels that are enabled contains any readings that fall outside of these high- and low-ADC Channel [1-3] Data thresholds, the  $\overline{\text{OUTSPEC}}$  pin will be pulsed four times. If the request comes after the mission has started (i.e., MIP = 1), but before the first sample has been recorded, the  $\overline{\text{INSPEC}}$  and  $\overline{\text{OUTSPEC}}$  pins will generate a total of four low pulses alternately, starting with the  $\overline{\text{OUTSPEC}}$  pin.

The DS1616 provides two methods for the user to request the status of the data. The first method is to send the Specification Test command over the serial interface. The second method is by holding the  $\overline{\text{ST}}$  pin low for at least half a second after the datalogger has already been started.

## **CLOCK, CALENDAR, AND ALARM**

The time and calendar information is accessed by reading/writing the appropriate register bytes. Note that some bits are set to 0. These bits will always read 0 regardless of how they are written. The contents of the time, calendar, and alarm registers are in the Binary-Coded Decimal (BCD) format and Year 2000 compliant.

The RTC can be read at any time and the values used in other parts of the system outside the data logger by issuing a Read Page command for memory page 0. See figure 2C for more details on the RTC memory map.

The DS1616 can run in either 12-hour or 24-hour mode. Bit 6 of the hours register is defined as the 12- or 24-hour mode select bit. When high, the 12-hour mode is selected. In the 12-hour mode, bit 5 is the AM/PM bit with logic 1 being PM. In the 24-hour mode, bit 5 is the second 10-hour bit (20-23 hours).

The DS1616 also contains a time of day alarm. The alarm registers are located in registers 0007h to 000Ah. Bit 7 of each of the alarm registers are mask bits (see Table 2). When all of the mask bits are logic 0, an alarm will occur once per week when the values stored in timekeeping registers 0000h to 0003h match the values stored in the time of day alarm registers. An alarm will be generated every day when mask bit of the day alarm register is set to 1. An alarm will be generated every hour when the day and hour alarm mask bits are set to 1. Similarly, an alarm will be generated every minute when the day, hour, and minute alarm mask bits are set to 1. When day, hour, minute, and seconds alarm mask bits are set to 1, an alarm will occur every second.

As a security measure to prevent unauthorized tampering, changing any value in the RTC and Control registers (with the exception of the Status registers) will stop a datalog mission and clear the Mission-in-Progress (MIP) bit.

**TIME OF DAY ALARM BITS Table 2**

ALARM REGISTER MASK BITS (bit 7)				
SECONDS MS	MINUTES MM	HOURS MH	DAYS MD	
1	1	1	1	ALARM ONCE PER SECOND
0	1	1	1	ALARM WHEN SECONDS MATCH
0	0	1	1	ALARM WHEN MINUTES AND SECONDS MATCH
0	0	0	1	ALARM WHEN HOURS, MINUTES, AND SECONDS MATCH
0	0	0	0	ALARM WHEN DAY, HOURS, MINUTES, AND SECONDS MATCH

**SPECIAL PURPOSE REGISTERS**

The following description defines the operation of the special function registers of the DS1616.

**CONTROL 1 REGISTER**

MSb							LSb
$\overline{\text{EOSC}}$	CLR	0	SE	RO	TLIE	THIE	AIE

$\overline{\text{EOSC}}$  - Enable oscillator - This bit controls the state of the oscillator in battery back-up mode only. When set to logic 0, the oscillator is active. When this bit is set to a logic 1, the oscillator is stopped and the DS1616 is placed into a low-power standby mode with a current drain of less than 100 nanoamps at room temperature. When  $V_{cc}$  is applied or when  $MIP = 1$ , the oscillator is active regardless of the state of this bit.

**CLR** - Clear Enable - This bit enables the Clear Memory command. When this bit is set to a 1 and the Clear Memory command is subsequently issued, the datalog, histogram, Temperature Alarm, Current Samples, Start Time Stamp, Start Delay, Sample Rate register, and ADC Data Alarm are all cleared to 0. Following the issuing of the Clear Memory command, the CLR bit is also cleared to 0. If the Clear Enable bit is set, but a command other than the Clear Memory command is issued next, the CLR bit is cleared to a 0 and the contents of the datalog, histogram, temperature alarms, Current Samples registers, Start Delay, Sample Rate, and ADC Data alarm register are unchanged.

**SE** - Start Enable - This bit enables the “start” function of the  $\overline{\text{ST}}$  input. When SE is a logic 1, the  $\overline{\text{ST}}$  input is enabled as the start pin for datalogging operation. When enabled, datalogging operation begins when the Sample Rate register contains a non-0 value AND the  $\overline{\text{ST}}$  pin has been held low for at least 0.5 seconds. When SE is a logic 0, writing any non-0 value to the Sample Rate register will start datalogging operation.

Once datalog operation has been initiated, the first data sample occurs after the specified delay written to the Start Delay register has elapsed.

**RO** - Roll-Over - This bit determines whether the datalog function of the DS1616 rolls over or stops writing data to the datalog memory in the event that the datalog memory is completely filled. If RO is set to a 1, the datalog memory will “roll over” after all 2048 registers in the datalog memory have been used. In other words, after the 2048<sup>th</sup> register is written, the following sample will be written to register 0000, overwriting the original data. Likewise, subsequent samples will increment through the datalog registers, overwriting their data.

If RO is cleared to a 0, no further data samples will be written to the datalog memory after all datalog memory registers have been filled. Samples, however, will continue to be taken and the appropriate histogram registers will be incremented with each sample. Likewise, the temperature and ADC Data alarms will also continue to function.

**TLIE** - Temperature Low Interrupt Enable - When set to a logic 1, this bit permits the Temperature Low Flag (TLF) in the Status 1 register to assert  $\overline{\text{INT}}$ . When the TLIE bit is set to logic 0, the TLF bit does not initiate the  $\overline{\text{INT}}$  signal.

**THIE** - Temperature High Interrupt Enable - When set to a logic 1, this bit permits the Temperature High Flag (THF) in the Status 1 register to assert  $\overline{\text{INT}}$ . When the THIE bit is set to logic 0, the THF bit does not initiate the  $\overline{\text{INT}}$  signal.

**AIE** - Alarm Interrupt Enable - When set to a logic 1, this bit permits the Alarm Flag (ALMF) in the Status 1 register to assert  $\overline{\text{INT}}$ . When the AIE bit is set to logic 0, the ALMF bit does not initiate the  $\overline{\text{INT}}$  signal.

## STATUS 1 REGISTER

MSb				LSb			
DR	MEM CLR	MIP	SIP	LOBAT	TLF	THF	ALMF

**DR** - Data Ready - This bit indicates the status of the data value in the Current Temperature and/or ADC Data [1-3] registers after the Read Data command has been executed. When this bit is a logic 1, the DS1616 has completed the measurement of all of the selected channels ( $\text{CS}_x = 1$ ) and has written valid value(s) to the Current Temperature and/or Current ADC Data [1-3] registers. When this bit is a logic 0, the measurements have not been completed. This bit is cleared to 0 when the Read Data command is sent.

**MEM CLR** - Memory Cleared - This bit indicates that the datalog memory, histogram memory, Temperature Alarm, ADC Channel 1 Data Alarm, Current Samples, Start Time Stamp, Start Delay, and Sample Rate registers are all cleared to 0. MEM CLR is cleared to 0 when a datalog mission is started (i.e.,  $\text{MIP} = 1$ ).

**MIP** - Mission in Progress - This bit indicates the sampling status of the DS1616. If MIP is a logic 1, the device is currently on a “mission” in which it is operating in the data logging mode. The MIP bit is changed to a logic 1 immediately following 1) the writing of a non-0 value to the Sample Rate register when the SE bit is a 0 or 2) a falling edge on the  $\overline{\text{ST}}$  pin if the Sample Rate register contains a non-0 value AND the SE bit is a 1.

If MIP is a logic 0, the DS1616 is not currently in datalogging mode. The MIP bit transitions from a logic 1 to a logic 0 whenever datalogging is stopped. Datalogging is stopped when the DS1616 is cleared via the clear bit and clear instruction or when any of the RTC or Control registers (with the exception of the Status registers) are written to during a mission. The MIP bit can also be written to a logic 0 by the end user to stop datalogging. It cannot, however, be written to a logic 1.

**SIP** - Sample in Progress - This bit indicates that the DS1616 is currently in the process of acquiring a temperature and/or ADC sample. When the SIP bit is 0, a data conversion is not currently in process and the next conversion will not begin for at least 250 ms. When the SIP bit is a 1, a data conversion is in progress and NO registers or memory locations should be read or written. The SIP bit will be a 1 for a maximum of 750 ms.

**LOBAT** - Low Battery Flag - This bit reflects the status of the backup power source connected to the  $V_{BAT}$  pin. A logic 1 for this bit indicates an exhausted lithium energy source.

**TLF** - Temperature Low Flag - A logic 1 in the Temperature Low Flag bit indicates that the temperature is/has been less than or equal to the value in the Temperature Low Threshold register. If TLIE is also a logic 1, the  $\overline{INT}$  pin will go low. TLF is cleared by writing this bit to a logic 0. The Clear Memory command has no effect on this bit.

**THF** - Temperature High Flag - A logic 1 in the Temperature High Flag bit indicates that the temperature is/has been greater than or equal to the value in the Temperature High Threshold register. If THIE is also a logic 1, the  $\overline{INT}$  pin will go low. THF is cleared by writing this bit to a logic 0. The Clear Memory command has no effect on this bit.

**ALMF** - Alarm Flag - A logic 1 in the Alarm Flag bit indicates that the current time has matched the time of day Alarm registers. If the AIE bit is also a logic 1, the  $\overline{INT}$  pin will go low. ALMF is cleared by writing this bit to a logic 0. The Clear Memory command has no effect on this bit.

## SAMPLE RATE REGISTER

MSb							LSb
SR7	SR6	SR5	SR4	SR3	SR2	SR1	SR0

The data sample rate for the DS1616 can range from once per minute to once per 255 minutes. The rate is equal to the value written to the Sample Rate register multiplied by one minute.

This register can only be written to a new value when the MEM CLR bit in the Status 1 register is set to 1. In other words, once a datalog mission has started, it cannot be changed without first issuing the Clear Memory command.

The Sample Rate register is cleared by issuing the Clear Memory command.

## START DELAY RESISTER

MSb							LSb
D15	D14	D13	D12	D11	D10	D9	D8
D7	D6	D5	D4	D3	D2	D1	D0

The Start Delay register determines the amount of delay before the DS1616 begins to take data measurements. The amount of the delay is roughly equal to the value in the register multiplied by one minute. If the register contains 00h, the first sample will begin when the seconds register rolls over from 59 to 00.

The value in this register decrements each time the seconds register rolls over from 59 to 00 until the Start Delay register reaches a value of 00h.

## TEMPERATURE-HIGH THRESHOLD REGISTER

MSb							LSb
TH7	TH6	TH5	TH4	TH3	TH2	TH1	TH0

This register determines the high threshold for interrupt generation from the thermal sensor. If the temperature is greater than or equal to the value in this register, an interrupt will be activated if the Temperature High Interrupt Enable (THIE) bit is set to a logic 1.

## TEMPERATURE-LOW THRESHOLD REGISTER

MSb							LSb
TL7	TL6	TL5	TL4	TL3	TL2	TL1	TL0

This register determines the low threshold for interrupt generation from the thermal sensor. If the temperature is less than or equal to the value in this register, an interrupt will be activated if the Temperature Low Interrupt Enable (TLIE) bit is set to a logic 1.

## CURRENT TEMPERATURE REGISTER

MSb							LSb
CT7	CT6	CT5	CT4	CT3	CT2	CT1	CT0

This register provides the most recently acquired temperature measurement if the CS0 bit in the Control 2 Register is set to 1. Otherwise, the value will be all 1s and will not be reported by the Read Data command. It contains either the most recently measured sample from automatic datalogging or it contains data that was acquired in response to a user's instruction for an immediate temperature measurement. When the DS1615 is not on a mission, an immediate measurement is acquired by issuing the Read Data command with CS0 set to 1.

After issuing the Read Data command, the value in this register is valid only if the Data Ready (DR) bit in the Status 1 register is a logic 1.

## CURRENT SAMPLES COUNTER

This 3-byte register set provides the number of samples that have been logged during the current data logging operation (also known as a "mission"). The contents of this register can be used by software to point to the most recent data sample in the Datalog NV RAM. The data in these registers are cleared by enabling and issuing the Clear Memory command.

## TOTAL SAMPLES COUNTER

This three-byte register set provides the total number of data samples that have been logged during the life of the product. This value cannot be written by the end user. The value in this register is maintained as long as the lithium energy source is available.

## CURRENT ADC DATA REGISTERS [1-3]

MSb							LSb
CA7	CA6	CA5	CA4	CA3	CA2	CA1	CA0

These registers provide the most recently acquired ADC inputs. For the ADC channels that are enabled with the CS[1-3] bits in the Control 2 register set to 1. Otherwise, the value in the corresponding Current ADC Data [1-3] register will be all 0s and not reported by the Read Data command. It contains either the most recently measured sample from automatic datalogging or it contains data that was acquired in response to a user's instruction for an immediate ADC conversion. When the DS1616 is not on a mission, an immediate measurement is acquired by issuing the Read Data command with CSx set to a 1.

After issuing the Read Data command, the value in this register is valid only if the Data Ready (DR) bit in the Status 2 register is a logic 1.

## ADC DATA-HIGH THRESHOLD REGISTERS [1-3]

MSb						LSb	
AH7	AH6	AH5	AH4	AH3	AH2	AH1	AH0

These registers determines the high threshold for interrupt generation from the three muxed ADC inputs. If the data is greater than or equal to the value in the corresponding register, an interrupt will be activated if the Data High Interrupt Enable (AHIE) bit is set to a logic 1.

## ADC DATA-LOW THRESHOLD REGISTERS [1-3]

MSb						LSb	
AL7	AL6	AL5	AL4	AL3	AL2	AL1	AL0

These registers determines the low threshold for interrupt generation from the three muxed ADC inputs. If the data is less than or equal to the value in the corresponding register, an interrupt will be activated if the Data Low Interrupt Enable (ALIE) bit is set to a logic 1.

## CONTROL 2 REGISTER

MSb						LSb	
0	CS0	CS1	CS2	CS3	ALIE	AHIE	0

**CSx** - Channel Select [0-3] - The value of these bits determines which channels are enabled. A 1 in the CSx bit enables the channel for data collection, recording and reporting. A 0 in the CSx bit disables the channel so data will not be taken, recorded, or reported. This causes a common problem in retrieving data, if the CSx bit is set to 0, the datalog and histogram data will not be downloaded from the DS1616.

**ALIE** - ADC Data Low Interrupt Enable - When set to a logic 1, this bit permits the ADC Data Low Flag [1-3] (ALFx[1-3]) in the Status 2 register to assert  $\overline{INT}$ . When the ALIE bit is set to logic 0, the ALF bit does not initiate the  $\overline{INT}$  signal.

**AHIE** - ADC Data High Interrupt Enable - When set to a logic 1, this bit permits the ADC Data High Flag [1-3] (AHFx[1-3]) in the Status 2 register to assert  $\overline{INT}$ . When the AHIE bit is set to logic 0, the AHF bit does not initiate the  $\overline{INT}$  signal.

## STATUS 2 REGISTER

MSb								LSb
0	ALF1	AHF1	ALF2	AHF2	ALF3	AHF3	0	

**ALF<sub>x</sub>** - ADC Data Low Flag [1-3] - A logic 1 in the ADC Data Low Flag [1-3] bits indicate that the ADC Channel [1-3] Data from the corresponding channel is/has been less than or equal to the value in the corresponding ADC Data Low Threshold [1-3] register. If ALIE is also a logic 1, the  $\overline{\text{INT}}$  pin will go low. ALF<sub>x</sub> is cleared by writing this bit to a logic 0. The Clear Memory command has no effect on this bit.

**AHF<sub>x</sub>** - ADC Data High Flag [1-3] - A logic 1 in the ADC Data High Flag [1-3] bits indicate that the corresponding ADC Channel [1-3] Data is/has been greater than or equal to the value in the corresponding ADC Data High Threshold [1-3] register. If AHIE is also a logic 1, the  $\overline{\text{INT}}$  pin will go low. AHF<sub>x</sub> is cleared by writing this bit to a logic 0. The Clear Memory command has no effect on this bit.

## SILICON SERIAL NUMBER

A unique 64-bit lasered serial number is located in the register bank. This serial number is divided into three parts. The first byte contains a model number to identify the device type (19h). The next six registers contain a unique binary number. The last serial number byte contains a CRC byte used to validate the data in the first seven serial number registers. All 8 bytes of the serial number are read-only registers.

The DS1616 is manufactured such that no two devices will contain an identical serial number. Blocks of numbers can be reserved by the customer. Contact Dallas Semiconductor for special ordering information for devices with reserved blocks of serial numbers.

## SECURITY

The DS1616 provides several measures to insure data integrity for the end user. These security measures are intended to prevent third party intermediaries from tampering with the data that has been stored in the Datalog and Histogram memory.

As a first security measure, the Datalog and Histogram memory are read-only from the perspective of the end user. The DS1616 can write sampled data into these memory banks, but the end user cannot write data to individual registers. This prevents an unscrupulous intermediary from writing false data to the DS1616. The end user, however, can clear the contents of the Datalog and Histogram memory. This is accomplished by enabling and issuing the Clear Memory command.

A second security feature lies in the fact that once the sample rate has been selected by writing to the Sample Rate register, it cannot be changed to another value without resetting the recorded data. This prevents gathering many data samples at a fast sample rate and then lowering the sample rate to give the appearance that the data was recorded over a longer period of time. The Sample Rate register can only be written to a new value if the MEM CLR bit is set to 1.

A third security feature lies in the two integrated sample counters, the Current Samples Counter and the Total Samples Counter. These two counters can be used to guarantee that the DS1616 data has not been cleared at any time during a given period of time. The Current Samples Counter counts the number of samples that have occurred since the most recent data acquisition operation was started (i.e., the number

of samples since the Sample Rate register was written to a non-0 value). The Total Samples Counter counts the total number of samples that have been recorded in the life of the device (assuming the lithium energy source has not been removed during that time). If the end user knows the value in the Total Samples Counter before the data acquisition operation is started, he can guarantee that the DS1616 has not been cleared. If the Current Samples count equals the difference between the ending value and beginning value of the Total Samples Counter, then the DS1616 data has not been cleared during that time frame.

As a fourth security measure, changing any value in the RTC and Control registers (with the exception of the Status registers) will stop datalogging and clear the Mission-in-Progress (MIP) bit.

## SERIAL INTERFACE

The DS1616 provides two different serial communications options; asynchronous and synchronous. Both communications options transmit the data LSb First/MSb last.

The mode of communication is selected via the COMSEL pin. When this pin is pulled high, the DS1616 operates in synchronous mode. In this mode, communication with the DS1616 is facilitated by the SCLK, I/O, and  $\overline{\text{RST}}$  pins. When COMSEL is pulled low or floated, asynchronous communications is selected and communication with the device occurs over the TX and RX pins. The operation of each mode is discussed in further detail below.

### Asynchronous Communication

In asynchronous mode, the DS1616 operates as a slave peripheral device which is read and written over a half duplex asynchronous data interface at the fixed rate of 9,600 bits per second. Data is received and transmitted in 8-bit bytes using a standard asynchronous serial communications format as shown in Figure 3. This format is easily generated by the UART in most systems. The DS1616 data format implements 10-bit words including 1 start bit, 8 data bits, and 1 stop bit. Data is received by the DS1616 on the RX pin and transmitted by the TX pin.

### COMMUNICATION WORD FORMAT Figure 3

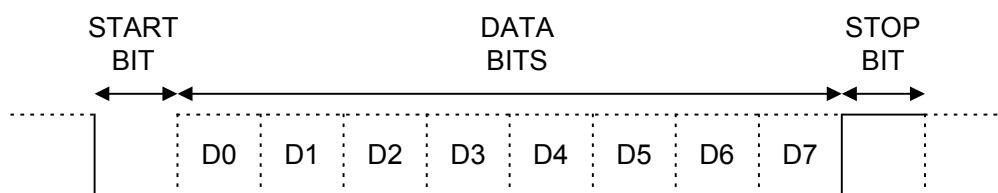

### Synchronous Communication

Synchronous communication is accomplished over the 3-wire bus which is composed of three signals. These are the  $\overline{\text{RST}}$  (reset), the SCLK (serial clock), and I/O (data I/O) pins. The 3-wire bus operates at a maximum data rate of 2 Mbps. All data transfers are initiated by driving the  $\overline{\text{RST}}$  input high and are terminated by driving  $\overline{\text{RST}}$  low. (See Figures 7 and 8.) A clock cycle is a sequence of a falling edge followed by a rising edge. For data inputs, the data must be valid during the rising edge. Data bits are output on the falling edge of the clock and remain valid through the rising edge.

When reading data from the DS1616, the I/O pin goes to a high impedance state when the clock is high. Taking  $\overline{\text{RST}}$  low will terminate any communication and cause the I/O pin to go to a high impedance state.



## Communication Reset (Asynchronous Mode)

When transmitting the command, parameters, or data to the DS1616, it is possible that communication might be interrupted. For example, the user might accidentally disconnect the cable linking the device to the host computer. To insure that communication always starts at a known state when in the asynchronous mode, the DS1616 will reset the communication if it senses a problem. This is accomplished via two methods. First, if during the transmission of a byte of data to the DS1616, the stop bit is not received, communication will be reset. The lack of a valid stop bit indicates that that particular byte of data was not received correctly. Second, if more than 10-bit times expire between the reception of 1 byte of data and the reception of the next required byte, then communication will be reset.

Automatic resetting of communication is not required when communicating in the synchronous mode. This is because of the function of the  $\overline{\text{RST}}$  pin. Pulling  $\overline{\text{RST}}$  low resets the serial communication of the DS1616.

## DS1616 COMMANDS

All communication with the DS1616 is accomplished by writing a command to the device followed by parameter byte/s if required. Table 3 illustrates the commands supported by the DS1616.

The DS1616 commands are summarized below. Note that if an invalid command is issued, no action is taken by the device.

**DS1616 COMMANDS Table 3**

COMMAND	FUNCTION	DESCRIPTION
22h	Write Byte	Write 1 byte to RTC, Control registers, and User NV RAM
33h	Read Page	Read Page
44h	Specification Test	Poll status of temperature and/or ADC Data extremes
55h	Read Data	Instructs DS1616 to immediately measure the temperature (if CS0 = 1) and/or perform an analog to digital conversion on the ADC Channels Selected (if CS[1-3] = 1) and store the result in the Current Temperature and/or Current ADC Channel [1-3] register(s) when MIP = 0.
A5h	Clear Memory	This command clears the datalog, histogram, Temperature Alarm, ADC Channel 1 Alarm, Current Samples, Start Time Stamp, Start Delay, and Sample Rate registers when the Clear Enable bit (CLR) in the Control 1 register is set to a 1.

### 1. Write Byte (22h)

Host Transmit:

D7	D6	D5	D4	D3	D2	D1	D0
0	0	1	0	0	0	1	0
0	a6	a5	a4	a3	a2	a1	a0
d7	d6	d5	d4	d3	d2	d1	d0

DS1616 Response: None

Note that good programming practice insists that the Clear Memory command should be issued whenever the DS1616 is programmed to begin a new datalogging mission.

**2. Read Page (33h)**

Host Transmit:

D7	D6	D5	D4	D3	D2	D1	D0
0	0	1	1	0	0	1	1
a15	a14	a13	a12	a11	a10	a9	a8
a7	a6	a5	a4	a3	a2	a1	a0

DS1616 Response (Host Receives):

D7	D6	D5	D4	D3	D2	D1	D0
register a[15..0]							
↓							
register xxxh							

Where xxx represents the last register of the page that has been accessed.

When in asynchronous mode, the TX pin becomes inactive after the last register in the page and the CRC have been transmitted. In synchronous mode, the DS1616 will continue to transmit data as long as clocks are presented to the serial interface. If clocks are presented after the final data bit of the last register in the page, the DS1616 will wraparound to the first register in the page and sequentially transmit data as long as the clocks continue.

**3. Specification Test (44h)**

Host Transmit:

D7	D6	D5	D4	D3	D2	D1	D0
0	1	0	0	0	1	0	0

DS1616 Response (Host Receives): Either the  $\overline{\text{INSPEC}}$  or  $\overline{\text{OUTSPEC}}$  pin will generate four low pulses. Each pulse will be 62.5 ms in duration and will start every half-second.

This command instructs the DS1616 to generate four low pulses on either the  $\overline{\text{INSPEC}}$  or  $\overline{\text{OUTSPEC}}$  LED driver pins. The pin that is driven is dependent upon whether any data samples fell outside of the High- and Low-Temperature Threshold or the High- and Low-ADC Data boundaries. These pins, when used to drive LEDs, can be used to provide a quick visual confirmation as to whether the samples remained within the user-defined limits.

Note that the Specification test command is ignored if the  $\overline{\text{ST}}$  button is pulled to ground when the command is issued.

**4. Read Data (55h)**

Host Transmit:

D7	D6	D5	D4	D3	D2	D1	D0
0	1	0	1	0	1	0	1

DS1616 Response (Host Receives): When the device is not currently data logging (i.e., MIP = 0), the temperature and/or the analog input(s) is/are immediately converted and the value(s) is/are written to the Current Temperature and/or Current ADC Channel [1-3] Data registers. The channels that are enabled is determined by the CSx bits of the Control 2 Register set to 1.

The data value(s) obtained from this command is/are not stored in the datalog or histogram memory.

After this command has been executed, the user must read the Data Ready (DR) bit in the Status 1 register to determine if the measurements have been completed. If the DR bit is a logic 1, the measurement has been completed and the value(s) in the Current Temperature and/or Current ADC Channel [1-3] registers is/are valid. If the DR bit is a logic 0, the measurements have not been completed. This command functions only when MIP = 0 (i.e., the device is not currently datalogging). If MIP =1, the DS1616 takes no action in response to the command.

### 5. Clear Memory (A5h)

Host Transmit:

D7	D6	D5	D4	D3	D2	D1	D0
1	0	1	0	0	1	0	1

DS1616 Response: The contents of the datalog, histogram, Temperature Alarm, ADC Channel 1 Alarm, Current Samples, Start Time Stamp, Start Delay, Sample Rate, and ADC Data Alarm registers are cleared if the Clear Memory command has been enabled by setting the CLR bit in the Control 1 register to a one. After clearing the memory, the MEM CLR bit in the Status 1 register is set. The Clear Memory command functions only if the oscillator is active. The DS1616 is inaccessible for 500  $\mu$ s after the Clear Memory command has been issued.

**ABSOLUTE MAXIMUM RATINGS\***

Voltage on any pin, Relative to Ground	-0.3V to +7V
Operating Temperature	-40°C to +85°C
Storage Temperature	-55°C to +125°C
Soldering Temperature	See J-STD-020A specification

\* This is a stress rating only and functional operation of the device at these or any other conditions above those indicated in the operation sections of this specification is not implied. Exposure to absolute maximum rating conditions for extended periods of time may affect reliability.

**RECOMMENDED DC OPERATING CONDITIONS** (-40°C TO +85°C)

PARAMETER	SYMBOL	MIN	TYP	MAX	UNITS	NOTES
Power Supply Voltage	V <sub>CC</sub>	4.0	5.0	5.5	V	1
Input Logic 1	V <sub>IH</sub>	2.2		V <sub>CC</sub> +0.3	V	1
Input Logic 0	V <sub>IL</sub>	-0.3		+0.8	V	1
Battery Voltage	V <sub>BAT</sub>	2.7		90% of V <sub>CC</sub>	V	1

**DC ELECTRICAL CHARACTERISTICS** (-40°C TO +85°C)

PARAMETER	SYMBOL	MIN	TYP	MAX	UNITS	NOTES
Input Leakage	I <sub>LI</sub>	-1		+1	μA	
Input Leakage COMSEL Pin	I <sub>LIC</sub>		55	200	μA	
Logic 1 Output	V <sub>OH</sub>	2.4			V	
Logic 0 Output	V <sub>OL</sub>			0.4	V	
TX and I/O Pins Output Current @ 2.0V	I <sub>OH</sub>	-2.2			mA	
TX, I/O, and INT Pins Output Current @ 0.8V	I <sub>OL</sub>	4			mA	
INSPEC and OUTSPEC Output Current @ 0.8V	I <sub>OL</sub>	10			mA	
Active Supply Current	I <sub>CCA</sub>		2	10	mA	
Temperature Conversion Current	I <sub>TC</sub>			600	μA	
ADC Conversion Current	I <sub>ADCC</sub>			500	μA	
Oscillator Current	I <sub>OSC</sub>		300	500	nA	
Battery Standby Current (Oscillator Off)	I <sub>BAT</sub>			250	nA	
DS1616 Thermometer Error	T <sub>ERR</sub>			±2.0	°C	6
<b>ADC Accuracy</b>						
Offset Error	Offset			1	LSB	
Integral Non Linearity	INL			0.25	LSB	9
Differential Non Linearity	DNL			0.25	LSB	
Monotonicity		8			Bits	
Reference Voltage	V <sub>REF</sub>	1.98	2.04	2.10	V	8

**CAPACITANCE** $(T_A = 25^\circ\text{C})$ 

PARAMETER	SYMBOL	MIN	TYP	MAX	UNITS	NOTES
Input Capacitance	$C_I$		10		pF	
Crystal Capacitance	$C_X$		6		pF	

**AC ELECTRICAL CHARACTERISTICS** $(-40^\circ\text{C to } +85^\circ\text{C}; V_{CC} = 5.0\text{V} \pm 10\%)$ 

PARAMETER	SYMBOL	MIN	TYP	MAX	UNITS	NOTES
Vcc rise/fall time	$t_R/t_F$	3		500	ms	
Delay from $\overline{ST}$ to $\overline{INSPEC}$ or $\overline{OUTSPEC}$ Active	$t_{SS}$			560	ms	
Delay from Specification Test Command to $\overline{INSPEC}$ or $\overline{OUTSPEC}$ Active	$t_{CS}$			560	ms	
Temperature and All Three ADC Channels Data Conversion Time ( $CS_x = 1$ )	$t_{CONV}$		153	230	ms	
One ADC Data Channel Only Conversion Time (in response to Read Data command) $CS[1-3]=1$	$t_{DCONV}$		1	10	ms	
Temperature Only Conversion Time (in response to Read Data command) ( $CS_0 = 1$ )	$t_{TCONV}$		150	200	ms	
$\overline{INSPEC}$ and $\overline{OUTSPEC}$ Active Low Pulse Width	$t_{SL}$		62.5		ms	
$\overline{INSPEC}$ and $\overline{OUTSPEC}$ High Duration	$t_{SH}$		437.5		ms	

**ASYNCHRONOUS SERIAL INTERFACE TIMING** $(-40^\circ\text{C to } +85^\circ\text{C}; V_{CC} = 5.0\text{V} \pm 10\%)$ 

PARAMETER	SYMBOL	MIN	TYP	MAX	UNITS	NOTES
Data Rate	$f_{BIT}$	9,408	9,600	9,792	Bits/sec	2
Turnaround Time	$t_{TURN}$		$2/f_{BIT}$		s	

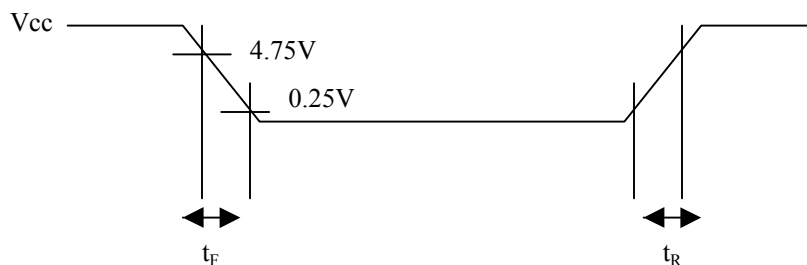
**POWER-UP/DOWN WAVEFORM TIMING Figure 5**

**SYNCHRONOUS (3-WIRE) SERIAL INTERFACE TIMING**(-40°C to +85°C;  $V_{CC} = 5.0V \pm 10\%$ )

PARAMETER	SYMBOL	MIN	TYP	MAX	UNITS	NOTES
Data to SCLK Setup	$t_{DC}$	50			ns	3
SCLK to Data Hold	$t_{CDH}$	70			ns	3
SCLK to Data Delay	$t_{CDD}$			200	ns	3,4,5
SCLK Low Time	$t_{CL}$	250			ns	3
SCLK High Time	$t_{CH}$	250			ns	3
SCLK Frequency	$t_{CLK}$	DC		2.0	MHz	3
SCLK Rise and Fall	$t_R, t_F$			500	ns	
$\overline{RST}$ to SCLK Setup	$t_{CC}$	1			$\mu s$	3
SCLK to $\overline{RST}$ Hold	$t_{CCH}$	60			ns	3
$\overline{RST}$ Inactive Time	$t_{CWH}$	1			$\mu s$	3
$\overline{RST}$ to I/O High Z	$t_{CDZ}$			70	ns	3, 7
SCLK to I/O High Z	$t_{CCZ}$			70	ns	3, 7

**NOTES:**

- All voltages are referenced to ground,
- The data rate  $f_{BIT}$  is equal to  $1/t_{BIT}$
- Measured with  $V_{IH} = 3.0V$  or  $V_{IL} = 0V$ .
- Measured at  $V_{OH}=2.4V$  or  $V_{OL}=0.4V$ .
- Load Capacitance = 50 pF.
- Thermometer error reflects temperature error as tested during calibration.
- Sampled with 5 pF load. Not 100% tested.
- The internal reference of 2.04V is set so that the ADC will work down to the minimum battery voltage of 2.7V. The ADC input voltage must not be greater than the battery voltage.
- The Integral Non-linearity does not take into consideration the tolerance of the Voltage Reference.

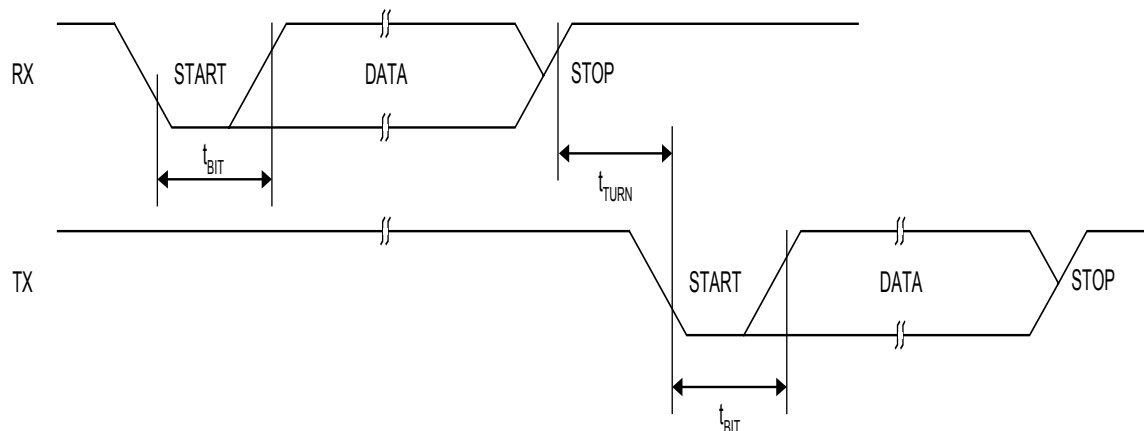
**ASYNCHRONOUS SERIAL INTERFACE TIMING Figure 6**

**SYNCHRONOUS (3-WIRE) SERIAL INTERFACE READ TIMING Figure 7**

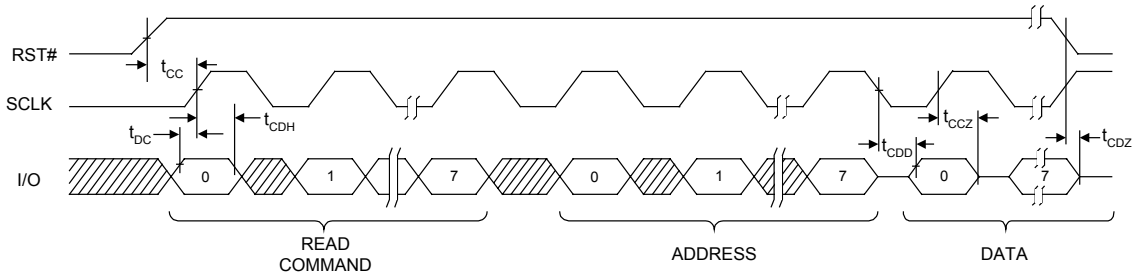

**SYNCHRONOUS (3-WIRE) SERIAL INTERFACE WRITE TIMING Figure 8**

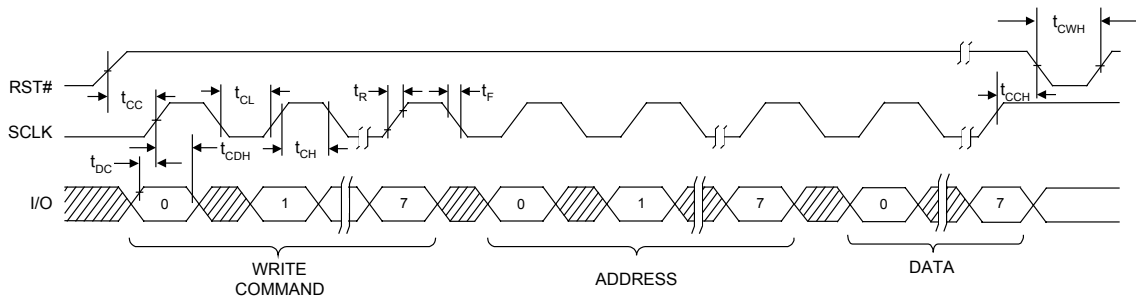

**SPECIFICATION POLLING FROM  $\overline{ST}$  INPUT Figure 9**

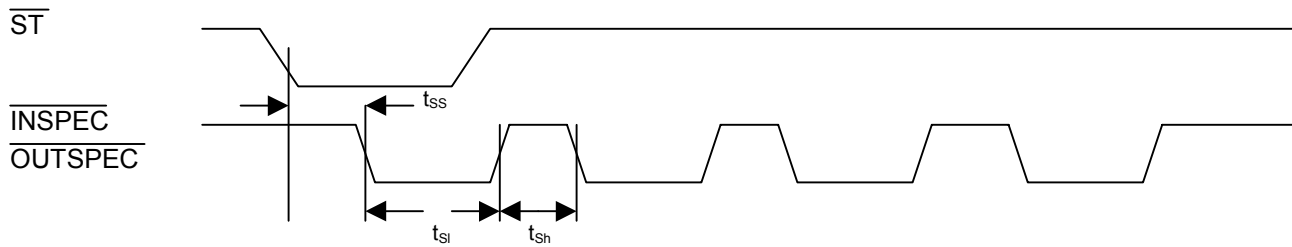

**SPECIFICATION POLLING FROM COMMAND Figure 10**

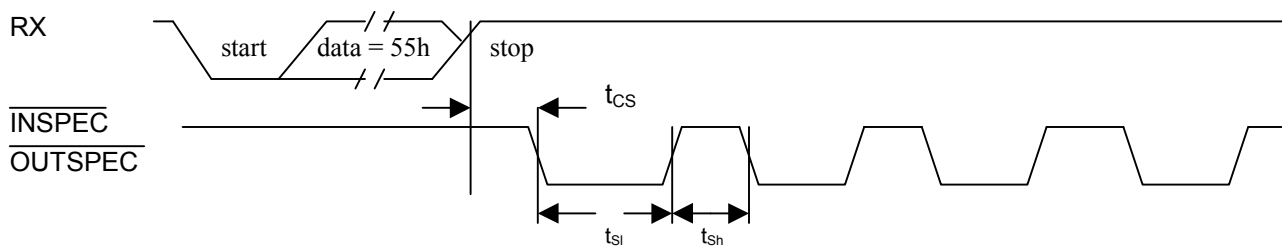

## Looking for pricing, stock, or lifecycle information?

Click below to explore more details on WIN SOURCE:

 [View DS1616K-000 on WIN SOURCE](#)

 [Maxim Integrated Information](#)

## Optimize Your Supply Chain with WIN SOURCE Solutions

-  Global Sourcing Solution
-  Obsolete Management
-  Cost Control Management
-  Shortage Management
-  Alternative Solution
-  Excess Inventory Management