



**THE DATASHEET OF  
DS125BR820NJYT**



# DS125BR820 Low-Power 12.5 Gbps 8-Channel Linear Repeater

## 1 Features

- Low 70 mW/Channel (Typ) Power Consumption, with Option to Power Down Unused Channels
- Seamless Link Training Support
- Enables Host ASIC to Meet Front-Port Eye Mask Requirements over Longer Reach
- Advanced Configurable Signal Conditioning I/O
  - Receive CTLE up to 10 dB at 6 GHz
  - Linear Output Driver
  - Variable Output Voltage Range up to 1200 mVp-p
- Programmable via Pin Selection, EEPROM, or SMBus Interface
- Single Supply Voltage: 2.5 V or 3.3 V
- -40°C to 85°C Operating Temperature Range
- Flow-Thru Layout in 10 mm × 5.5 mm 54-Pin Leadless WQFN Package

## 2 Applications

- Front-Port 40G-CR4/SR4/LR4 Link Extension
- Backplane 40G-KR4 Link Extension
- SAS/SATA/PCIe Link Extension
- Other Proprietary High Speed Interfaces up to 12.5 Gbps

## 3 Description

The DS125BR820 is an extremely low-power high-performance repeater/redriver designed to support eight channels carrying high speed interface up to 12.5 Gbps, such as 40G-CR4, 40G-KR4, SAS/SATA, and PCIe. The receiver's continuous time linear equalizer (CTLE) provides high frequency boost that is programmable from 3 to 10 dB at 6 GHz (12 Gbps) followed by a linear output driver. The CTLE receiver is capable of opening an input eye that is completely closed due to inter symbol interference (ISI) induced by interconnect medium such as board traces or twin axial-copper cables. The programmable equalization maximizes the flexibility of physical placement within the interconnect channel and improves overall channel performance.

When operating in 40G-CR4/KR4, SAS/SATA, and PCIe applications, the DS125BR820 preserves transmit signal characteristics, thereby allowing the host controller and the end point to negotiate transmit equalizer coefficients. This transparency in the link training protocol facilitates system level interoperability and minimizes latency.

The programmable settings can be applied easily via pin control, software (SMBus or I2C), or direct loading from an external EEPROM. In EEPROM mode, the configuration information is automatically loaded on power up, thereby eliminating the need for an external microprocessor or software driver.

### Simplified Functional Block Diagram

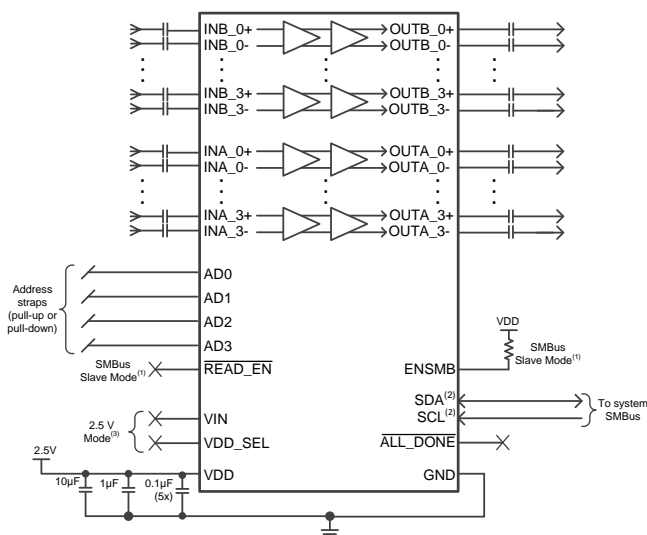

(1) Schematic requires different connections for SMBus Master Mode and Pin Mode  
 (2) SMBus signals need to be pulled up elsewhere in the system.  
 (3) Schematic requires different connections for 3.3 V mode

### Device Information<sup>(1)</sup>

| PART NUMBER | PACKAGE   | BODY SIZE (NOM) |
|-------------|-----------|-----------------|
| DS125BR820  | WQFN (54) | 10 mm × 5.5 mm  |

(1) For all available packages, see the orderable addendum at the end of the datasheet.

### Typical Application Block Diagram

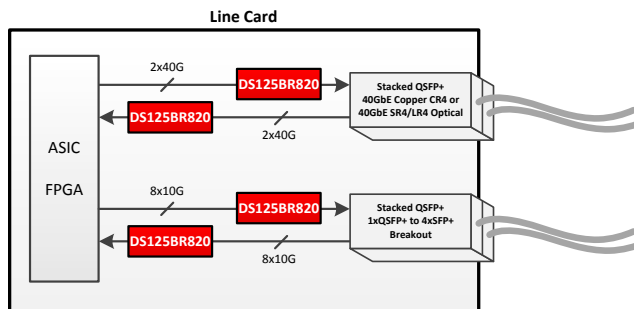

## Table of Contents

|   |           |  |           |
|---|-----------|--|-----------|
| <b>1 Features</b> .....   | <b>1</b>  | 7.3 Feature Description .....                                    | 14        |
| <b>2 Applications</b> .....   | <b>1</b>  | 7.4 Device Functional Modes .....                                | 14        |
| <b>3 Description</b> .....  | <b>1</b>  | 7.5 Signal Conditioning Settings .....                           | 15        |
| <b>4 Revision History</b> .....   | <b>2</b>  | 7.6 Programming .....  | 17        |
| <b>5 Pin Configuration and Functions</b> .....                                | <b>3</b>  | 7.7 Register Maps .....  | 25        |
| <b>6 Specifications</b> .....   | <b>7</b>  | <b>8 Applications and Implementation</b> .....                   | <b>40</b> |
| 6.1 Absolute Maximum Ratings .....  | 7         | 8.1 Application Information .....                                | 40        |
| 6.2 ESD Ratings .....   | 7         | 8.2 Typical Applications .....                                   | 41        |
| 6.3 Recommended Operating Conditions .....                                    | 7         | <b>9 Power Supply Recommendations</b> .....                      | <b>52</b> |
| 6.4 Thermal Information .....   | 7         | <b>10 Layout</b> .....   | <b>53</b> |
| 6.5 Electrical Characteristics .....  | 8         | 10.1 Layout Guidelines .....                                     | 53        |
| 6.6 Electrical Characteristics — Serial Bus Interface DC Specifications ..... | 10        | 10.2 Layout Example .....  | 53        |
| 6.7 <b>Serial Bus Interface Timing Specifications</b> .....                   | 10        | <b>11 Device and Documentation Support</b> .....                 | <b>54</b> |
| 6.8 Typical Characteristics .....   | 12        | 11.1 Trademarks .....  | 54        |
| <b>7 Detailed Description</b> .....   | <b>13</b> | 11.2 Electrostatic Discharge Caution .....                       | 54        |
| 7.1 Overview .....  | 13        | 11.3 Glossary .....  | 54        |
| 7.2 Functional Block Diagram .....  | 13        | <b>12 Mechanical, Packaging, and Orderable Information</b> ..... | <b>54</b> |

## 4 Revision History

| <b>Changes from Revision A (September 2014) to Revision B</b>   | <b>Page</b> |
|---|-------------|
| • Added data type for all differential high speed I/O .....   | 4           |
| • Changed pin assignment numbers for OUTB_2+/- and OUTB_3+/- to correct typo .....  | 4           |
| • Changed ENSMB pin type to 4-level LVCMOS per input pin behavior .....   | 4           |
| • Changed Handling Ratings table to ESD Ratings table .....   | 7           |
| • Changed register map rows to combine multiple consecutive registers with a value of all zeros and no EEPROM-relevant bits ..... | 28          |

| <b>Changes from Original (July 2014) to Revision A</b> | <b>Page</b> |
|--|-------------|
| • Added release of the full document .....             | 1           |

## 5 Pin Configuration and Functions

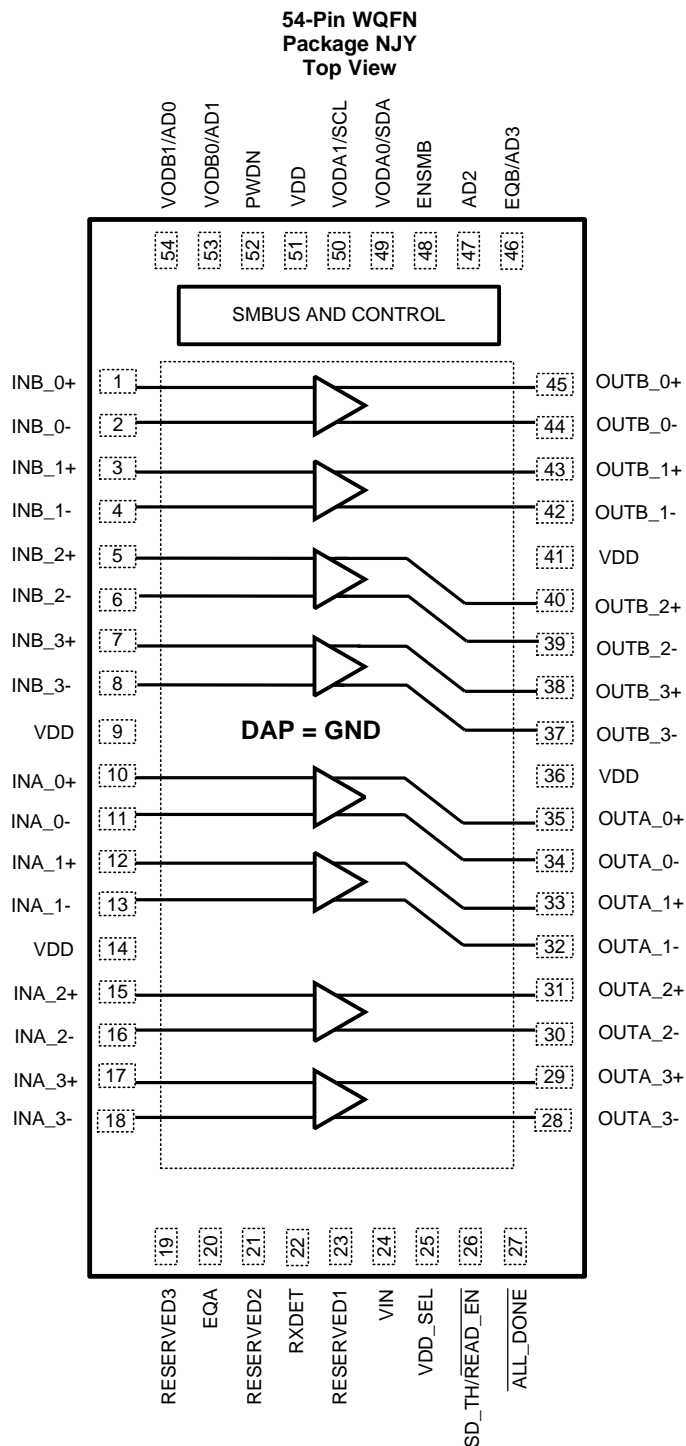

NOTE: Above 54-lead WQFN graphic is a TOP VIEW, looking down through the package.

**Pin Functions<sup>(1)</sup>**

| PIN   |                                      | I/O, TYPE                   | PIN DESCRIPTION  |
|---|--------------------------------------|-----------------------------|--|
| NAME  | NO.                                  |                             |  |
| <b>DIFFERENTIAL HIGH SPEED I/O</b>  |                                      |                             |  |
| INB_0+, INB_0-,<br>INB_1+, INB_1-,<br>INB_2+, INB_2-,<br>INB_3+, INB_3-         | 1, 2<br>3, 4<br>5, 6<br>7, 8         | I, CML                      | Inverting and non-inverting CML differential inputs to the equalizer. On-chip 50 Ω termination resistor connects INB_n+ to VDD and INB_n- to VDD depending on the state of RXDET. See <a href="#">Table 2</a> . AC coupling required on high-speed I/O     |
| OUTB_0+, OUTB_0-,<br>OUTB_1+, OUTB_1-,<br>OUTB_2+, OUTB_2-,<br>OUTB_3+, OUTB_3- | 45, 44<br>43, 42<br>40, 39<br>38, 37 | O, CML                      | Inverting and non-inverting 50 Ω driver outputs. Compatible with AC coupled CML inputs. AC coupling required on high-speed I/O   |
| INA_0+, INA_0-,<br>INA_1+, INA_1-,<br>INA_2+, INA_2-,<br>INA_3+, INA_3-         | 10, 11<br>12, 13<br>15, 16<br>17, 18 | I, CML                      | Inverting and non-inverting CML differential inputs to the equalizer. On-chip 50 Ω termination resistor connects INA_n+ to VDD and INA_n- to VDD depending on the state of RXDET. See <a href="#">Table 2</a> . AC coupling required on high-speed I/O     |
| OUTA_0+, OUTA_0-,<br>OUTA_1+, OUTA_1-,<br>OUTA_2+, OUTA_2-,<br>OUTA_3+, OUTA_3- | 35, 34<br>33, 32<br>31, 30<br>29, 28 | O, CML                      | Inverting and non-inverting 50 Ω driver outputs. Compatible with AC coupled CML inputs. AC coupling required on high-speed I/O   |
| <b>CONTROL PINS — SHARED (LVCMOS)</b>   |                                      |                             |  |
| ENSMB   | 48                                   | I, 4-LEVEL,<br>LVCMOS       | System Management Bus (SMBus) Enable Pin<br>Tie 1 kΩ to VDD = Register Access SMBus Slave Mode<br>FLOAT = Read External EEPROM (SMBus Master Mode)<br>Tie 1 kΩ to GND = Pin Mode   |
| <b>ENSMB = 1 (SMBus SLAVE MODE)</b>   |                                      |                             |  |
| SCL   | 50                                   | I, LVCMOS,<br>O, OPEN Drain | In SMBus Slave Mode, this pin is the SMBus clock I/O. Clock input or open drain output.<br>External 2 kΩ to 5 kΩ pull-up resistor to VDD or VIN recommended as per SMBus interface standards <sup>(2)</sup>  |
| SDA   | 49                                   | I, LVCMOS,<br>O, OPEN Drain | In both SMBus Modes, this pin is the SMBus data I/O. Data input or open drain output.<br>External 2 kΩ to 5 kΩ pull-up resistor to VDD or VIN recommended as per SMBus interface standards <sup>(2)</sup>  |
| AD0-AD3   | 54, 53, 47, 46                       | I, LVCMOS                   | SMBus Slave Address Inputs. In both SMBus Modes, these pins are the user set SMBus slave address inputs.<br>External 1 kΩ pull-up or pull-down recommended.<br>Note: In Pin Mode, AD2 must be tied via external 1 kΩ to GND.                               |
| RESERVED2   | 21                                   | I, 4-LEVEL,<br>LVCMOS       | Reserved<br>For applications requiring Signal Detect status register read-back:<br>• Leave Pin 21 floating.<br>• Write Reg 0x08[2] = 1 if Pin 21 is floating.<br>Otherwise, tie Pin 21 via external 1 kΩ to GND (External 1 kΩ to VDD is also acceptable). |
| RESERVED3   | 19                                   | I, 4-LEVEL,<br>LVCMOS       | Reserved<br>This input may be left floating, tied via 1 kΩ to VDD, or tied via 1 kΩ to GND.  |

(1) LVCMOS inputs without the "Float" conditions must be driven to a logic low or high at all times or operation is not ensured. Input edge rate for LVCMOS/FLOAT inputs must be faster than 50 ns from 10–90%.

For 3.3 V mode operation, VIN pin input = 3.3 V and the logic "1" or "high" reference for the 4-level input is 3.3 V.

For 2.5 V mode operation, VDD pin output = 2.5 V and the logic "1" or "high" reference for the 4-level input is 2.5 V.

(2) SCL and SDA pins can be tied either to 3.3 V or 2.5 V, regardless of whether the device is operating in 2.5 V mode or 3.3 V mode.

**Pin Functions<sup>(1)</sup> (continued)**

| PIN                                      |                | I/O, TYPE                   | PIN DESCRIPTION  |
|--|----------------|-----------------------------|--|
| NAME                                     | NO.            |                             |  |
| <b>ENSMB = Float (SMBus MASTER MODE)</b> |                |                             |  |
| SCL                                      | 50             | I, LVCMOS,<br>O, OPEN Drain | Clock output when loading EEPROM configuration, reverting to SMBus clock input when EEPROM load is complete (ALL_DONE = 0). External 2 kΩ to 5 kΩ pull-up resistor to VDD or VIN recommended as per SMBus interface standards <sup>(2)</sup>   |
| SDA                                      | 49             | I, LVCMOS,<br>O, OPEN Drain | In both SMBus Modes, this pin is the SMBus data I/O. Data input or open drain output. External 2 kΩ to 5 kΩ pull-up resistor to VDD or VIN recommended as per SMBus interface standards <sup>(2)</sup>   |
| AD0-AD3                                  | 54, 53, 47, 46 | I, LVCMOS                   | SMBus Slave Address Inputs. In both SMBus Modes, these pins are the user set SMBus slave address inputs. External 1 kΩ pull-up or pull-down recommended. Note: In Pin Mode, AD2 must be tied via external 1 kΩ to GND.   |
| $\overline{\text{READ\_EN}}$             | 26             | I, LVCMOS                   | A logic low on this pin starts the load from the external EEPROM <sup>(3)</sup> . Once EEPROM load is complete (ALL_DONE = 0), this pin functionality remains as READ_EN. It does not revert to an SD_TH input.  |
| RESERVED2                                | 21             | I, 4-LEVEL,<br>LVCMOS       | Reserved<br>For applications requiring Signal Detect status register read-back:<br><ul style="list-style-type: none"> <li>• Leave Pin 21 floating.</li> <li>• Write Reg 0x08[2] = 1 if Pin 21 is floating.</li> </ul> Otherwise, tie Pin 21 via external 1 kΩ to GND (External 1 kΩ to VDD is also acceptable).  |
| RESERVED3                                | 19             | I, 4-LEVEL,<br>LVCMOS       | Reserved<br>This input may be left floating, tied via 1 kΩ to VDD, or tied via 1 kΩ to GND.  |
| <b>ENSMB = 0 (PIN MODE)</b>              |                |                             |  |
| EQA<br>EQB                               | 20<br>46       | I, 4-LEVEL,<br>LVCMOS       | EQA and EQB pins control the level of equalization for the A-channels and B-channels, respectively. The pins are defined as EQA and EQB only when ENSMB is de-asserted (low). Each of the four A-channels have the same level unless controlled by the SMBus control registers. Likewise, each of the four B-channels have the same level unless controlled by the SMBus control registers. When the device operates in Slave or Master Mode, the SMBus registers independently control each lane, and the EQB pin is converted to an AD3 input. See <a href="#">Table 4</a> . |
| VODB0<br>VODB1                           | 53<br>54       | I, 4-LEVEL,<br>LVCMOS       | VODB[1:0] controls the output amplitude of the B-channels. The pins are defined as VODB[1:0] only when ENSMB is de-asserted (low). Each of the four B-channels have the same level unless controlled by the SMBus control registers. When the device operates in Slave or Master Mode, the SMBus registers provide independent control of each lane, and VODB[1:0] pins are converted to AD0, AD1 inputs. See <a href="#">Table 5</a> .  |
| VODA0<br>VODA1                           | 49<br>50       | I, 4-LEVEL,<br>LVCMOS       | VODA[1:0] controls the output amplitude of the A-channels. The pins are defined as VODA[1:0] only when ENSMB is de-asserted (low). Each of the four A-channels have the same level unless controlled by the SMBus control registers. When the device operates in Slave or Master Mode, the SMBus registers provide independent control of each lane and the VODA[1:0] pins are converted to SCL and SDA. See <a href="#">Table 5</a> .   |
| AD2                                      | 47             | I, LVCMOS                   | Reserved in Pin Mode (ENSMB = 0)<br>This input must be tied via external 1 kΩ to GND.  |
| SD_TH                                    | 26             | I, 4-LEVEL,<br>LVCMOS       | Controls the internal Signal Detect Status Threshold value when in Pin Mode and SMBus Slave Mode. This pin is to be used for system debugging only. See <a href="#">Table 3</a> for more information. For final designs, input can be left floating, tied via 1 kΩ to VDD, or tied via 1 kΩ to GND.  |
| RESERVED2                                | 21             | I, 4-LEVEL,<br>LVCMOS       | Reserved<br>Tie via external 1 kΩ to GND (External 1 kΩ to VDD is also acceptable).  |
| RESERVED3                                | 19             | I, 4-LEVEL,<br>LVCMOS       | Reserved<br>This input must be tied via external 1 kΩ to GND.  |

(3) When  $\overline{\text{READ\_EN}}$  is low, the device attempts to load EEPROM. If EEPROM cannot be loaded successfully, for example due to an invalid or blank hex file, the DS125BR820 hangs indefinitely in an unknown state. ALL\_DONE pin remains high in this situation.

**Pin Functions<sup>(1)</sup> (continued)**

| PIN   |                   | I/O, TYPE          | PIN DESCRIPTION   |
|---|-------------------|--------------------|---|
| NAME  | NO.               |                    |   |
| <b>CONTROL PINS — BOTH PIN AND SMBUS MODES (LVCMOS)</b> |                   |                    |   |
| RXDET   | 22                | I, 4-LEVEL, LVCMOS | The RXDET pin controls the input enable function. Depending on the input level, a 50 $\Omega$ or >50 k $\Omega$ termination to the power rail is enabled. Pull up pin to VDD (2.5 V mode) or VIN (3.3 V mode) through 1 k $\Omega$ resistor to provide a 50 $\Omega$ termination to the power rail for normal operation.<br>See <a href="#">Table 2</a> . |
| RESERVED1   | 23                | I, 4-LEVEL, LVCMOS | Reserved<br>This input must be left floating.   |
| VDD_SEL   | 25                | I, FLOAT           | Controls the internal regulator<br>Float = 2.5 V mode<br>Tie to GND = 3.3 V mode  |
| PWDN  | 52                | I, LVCMOS          | Tie High = Low power - Power Down<br>Tie to GND = Normal Operation<br>See <a href="#">Table 2</a> .   |
| <u>ALL_DONE</u>   | 27                | O, LVCMOS          | Valid Register Load Status Output<br>HIGH = External EEPROM load failed or incomplete<br>LOW = External EEPROM load passed  |
| <b>POWER</b>  |                   |                    |   |
| VIN   | 24                | Power              | In 3.3 V mode, feed 3.3 V to VIN<br>In 2.5 V mode, leave floating.  |
| VDD   | 9, 14, 36, 41, 51 | Power              | Power Supply for CML and Analog Pins<br>2.5 V mode, connect to 2.5 V<br>3.3 V mode, connect 0.1 $\mu$ F cap to each VDD Pin and GND<br>See <a href="#">Power Supply Recommendations</a> for proper power supply decoupling .  |
| GND   | DAP               | Power              | Ground pad (DAP - die attach pad).  |

## 6 Specifications

### 6.1 Absolute Maximum Ratings<sup>(1)</sup>

over operating free-air temperature range (unless otherwise noted)

|  | MIN  | MAX       | UNIT |
|--|------|-----------|------|
| Supply Voltage (VDD to GND, 2.5 V Mode)  | -0.5 | +2.75     | V    |
| Supply Voltage (VIN to GND, 3.3 V Mode)  | -0.5 | +4.0      | V    |
| LVCMOS Input/Output Voltage  | -0.5 | +4.0      | V    |
| CML Input Voltage  | -0.5 | VDD + 0.5 | V    |
| CML Input Current  | -30  | +30       | mA   |
| Storage temperature, T <sub>stg</sub>  | -40  | 125       | °C   |
| Lead Temperature Range Soldering (4 sec.) <sup>(2)</sup> , T <sub>solder</sub> |      | 260       | °C   |

- (1) "Absolute Maximum Ratings" indicate limits beyond which damage to the device may occur, including inoperability and degradation of device reliability and performance. Functional operation of the device and/or non-degradation at the Absolute Maximum Ratings or other conditions beyond those indicated in the Recommended Operating Conditions is not implied. The Recommended Operating Conditions indicate conditions at which the device is functional and the device should not be operated beyond such conditions. Absolute Maximum Numbers are ensured for a junction temperature range of -40°C to +125°C. Models are validated to Maximum Operating Voltages only.
- (2) For soldering specifications, see application note [SNOA549](#).

### 6.2 ESD Ratings

|  |  | VALUE | UNIT |
|--|--|-------|------|
| V <sub>(ESD)</sub> Electrostatic discharge | Human-body model (HBM), per ANSI/ESDA/JEDEC JS-001 <sup>(1)</sup>              | ±4000 | V    |
|  | Charged-device model (CDM), per JEDEC specification JESD22-C101 <sup>(2)</sup> | ±1000 |      |

- (1) JEDEC document JEP155 states that 500-V HBM allows safe manufacturing with a standard ESD control process. Manufacturing with less than 500-V HBM is possible with the necessary precautions. Pins listed as ±4000 V may actually have higher performance.
- (2) JEDEC document JEP157 states that 250-V CDM allows safe manufacturing with a standard ESD control process. Manufacturing with less than 250-V CDM is possible with the necessary precautions. Pins listed as ±1000 V may actually have higher performance.

### 6.3 Recommended Operating Conditions

over operating free-air temperature range (unless otherwise noted)

|  | MIN   | NOM | MAX   | UNIT  |
|--|-------|-----|-------|-------|
| Supply Voltage (2.5 V mode) <sup>(1)</sup> | 2.375 | 2.5 | 2.625 | V     |
| Supply Voltage (3.3 V mode) <sup>(1)</sup> | 3.0   | 3.3 | 3.6   | V     |
| Ambient Temperature                        | -40   |     | +85   | °C    |
| SMBus (SDA, SCL)                           |       |     | 3.6   | V     |
| Supply Noise up to 50 MHz <sup>(2)</sup>   |       | 100 |       | mVp-p |

- (1) DC plus AC power should not exceed these limits.
- (2) Allowed supply noise (mVp-p sine wave) under typical conditions.

### 6.4 Thermal Information

| THERMAL METRIC <sup>(1)</sup> |  | NJY     | UNIT |
|-------------------------------|--|---------|------|
|                               |  | 54 PINS |      |
| R <sub>θJA</sub>              | Junction-to-ambient thermal resistance       | 26.6    | °C/W |
| R <sub>θJctop</sub>           | Junction-to-case (top) thermal resistance    | 10.8    |      |
| R <sub>θJB</sub>              | Junction-to-board thermal resistance         | 4.4     |      |
| ψ <sub>JT</sub>               | Junction-to-top characterization parameter   | 0.2     |      |
| ψ <sub>JB</sub>               | Junction-to-board characterization parameter | 4.3     |      |
| R <sub>θJcbot</sub>           | Junction-to-case (bottom) thermal resistance | 1.5     |      |

- (1) For more information about traditional and new thermal metrics, see the *IC Package Thermal Metrics* application report, [SPRA953](#).

## 6.5 Electrical Characteristics

| PARAMETER   |   | TEST CONDITIONS   | MIN   | TYP  | MAX             | UNIT  |
|---|---|---|-------|------|-----------------|-------|
| <b>POWER</b>  |   |   |       |      |                 |       |
| I <sub>DD</sub>   | Current Consumption, 2.5 V Mode                                   | EQ = Level 4, VOD = Level 6<br>RXDET = 1, PWDN = 0  |       | 220  | 280             | mA    |
|   | Current Consumption, 3.3 V Mode                                   | EQ = Level 4, VOD = Level 6<br>RXDET = 1, PWDN = 0  |       | 220  | 280             | mA    |
|   | Power Down Current Consumption                                    | PWDN = 1  |       | 14   | 27              | mA    |
| V <sub>DD</sub>   | Integrated LDO Regulator  | V <sub>IN</sub> = 3.0 - 3.6 V   | 2.375 | 2.5  | 2.625           | V     |
| <b>LVC MOS / LV TTL DC SPECIFICATIONS</b>                     |   |   |       |      |                 |       |
| V <sub>IH25</sub>   | High Level Input Voltage  | 2.5 V Supply Mode   | 1.7   |      | V <sub>DD</sub> | V     |
| V <sub>IH33</sub>   | High Level Input Voltage  | 3.3 V Supply Mode   | 1.7   |      | V <sub>IN</sub> | V     |
| V <sub>IL</sub>   | Low Level Input Voltage   |   | 0     |      | 0.7             | V     |
| V <sub>OH</sub>   | High Level Output Voltage<br>(ALL_DONE pin)                       | I <sub>OH</sub> = -4mA  | 2.0   |      |                 | V     |
| V <sub>OL</sub>   | Low Level Output Voltage<br>(ALL_DONE pin)                        | I <sub>OL</sub> = 4mA   |       |      | 0.4             | V     |
| I <sub>IH</sub>   | Input High Current (PWDN pin)                                     | V <sub>IN</sub> = 3.6 V,<br>LVC MOS = 3.6 V   | -15   |      | +15             | μA    |
| I <sub>IL</sub>   | Input Low Current (PWDN pin)                                      | V <sub>IN</sub> = 3.6 V,<br>LVC MOS = 0 V   | -15   |      | +15             | μA    |
| <b>4-LEVEL INPUT DC SPECIFICATIONS</b>                        |   |   |       |      |                 |       |
| I <sub>IH</sub>   | Input High Current with internal resistors<br>(4-level input pin) | V <sub>IN</sub> = 3.6 V,<br>LVC MOS = 3.6 V   | +20   |      | +150            | μA    |
| I <sub>IL</sub>   | Input Low Current with internal resistors<br>(4-level input pin)  | V <sub>IN</sub> = 3.6 V,<br>LVC MOS = 0 V   | -160  |      | -40             | μA    |
| V <sub>TH</sub>   | Voltage Threshold from Pin Mode Level 0 to R                      | V <sub>DD</sub> = 2.5 V (2.5 V supply mode)<br>Internal LDO Disabled<br>See <a href="#">Table 1</a> for details |       | 0.50 |                 | V     |
|   | Voltage Threshold from Pin Mode Level R to F                      |   |       | 1.25 |                 |       |
|   | Voltage Threshold from Pin Mode Level F to 1                      |   |       | 2.00 |                 |       |
|   | Voltage Threshold from Pin Mode Level 0 to R                      | V <sub>IN</sub> = 3.3 V (3.3 V supply mode)<br>Internal LDO Enabled<br>See <a href="#">Table 1</a> for details. |       | 0.66 |                 | V     |
|   | Voltage Threshold from Pin Mode Level R to F                      |   |       | 1.65 |                 |       |
|   | Voltage Threshold from Pin Mode Level F to 1                      |   |       | 2.64 |                 |       |
| <b>CML RECEIVER INPUTS (IN<sub>n+</sub>, IN<sub>n-</sub>)</b> |   |   |       |      |                 |       |
| Z <sub>Rx-DIFF-DC</sub>                                       | Rx DC differential mode impedance                                 | Tested at V <sub>DD</sub> = 2.5 V   | 80    | 100  | 120             | Ω     |
| Z <sub>Rx-DC</sub>  | Rx DC single ended impedance                                      | Tested at V <sub>DD</sub> = 2.5 V   | 40    | 50   | 60              | Ω     |
| RL <sub>Rx-DIFF</sub>   | Rx Differential Input return loss                                 | SDD11 10 MHz  |       | -19  |                 | dB    |
|   |   | SDD11 2 GHz   |       | -14  |                 |       |
|   |   | SDD11 6-11.1 GHz  |       | -8   |                 |       |
| RL <sub>Rx-CM</sub>   | Rx Common mode return loss  | SCC11 0.05 - 5 GHz  |       | -10  |                 | dB    |
| V <sub>Rx-ASSERT-DIFF-PP</sub>                                | Signal detect assert level for active data signal                 | SD_TH = F (float),<br>1010 pattern at 12 Gbps   |       | 57   |                 | mVp-p |
| V <sub>Rx-DEASSERT-DIFF-PP</sub>                              | Signal detect de-assert for inactive signal level                 | SD_TH = F (float),<br>1010 pattern at 12 Gbps   |       | 44   |                 | mVp-p |

**Electrical Characteristics (continued)**

| PARAMETER                         |  | TEST CONDITIONS  | MIN | TYP  | MAX | UNIT   |
|-----------------------------------|--|--|-----|------|-----|--------|
| <b>HIGH SPEED OUTPUTS</b>         |  |  |     |      |     |        |
| RL <sub>Tx-DIFF</sub>             | Tx Differential return loss                                  | SDD22 10 MHz - 2 GHz   |     | -15  |     | dB     |
|                                   |  | SDD22 5.5 GHz  |     | -12  |     |        |
|                                   |  | SDD22 11.1 GHz   |     | -10  |     | dB     |
| RL <sub>Tx-CM</sub>               | Tx Common mode return loss                                   | SCC22 50 MHz- 2.5 GHz  |     | -8   |     | dB     |
| Z <sub>Tx-DIFF-DC</sub>           | DC differential Tx impedance                                 |  |     | 100  |     | Ω      |
| I <sub>Tx-SHORT</sub>             | Transmitter short circuit current limit                      | Total current when output is shorted to VDD or GND   |     | 20   |     | mA     |
| V <sub>Tx-CM-DC-LINE-DELTA</sub>  | Absolute delta of DC common mode voltage between Tx+ and Tx- |  |     |      | 25  | mV     |
| V <sub>Tx-DIFF1-PP</sub>          | Output Voltage Differential Swing                            | Differential measurement with OUT <sub>n+</sub> and OUT <sub>n-</sub> , AC-Coupled and terminated by 50 Ω to GND, Inputs AC-Coupled, Measured with 8T Pattern at 12 Gbps <sup>(1)</sup><br>VID = 600 mVp-p<br>VOD = Level 6 <sup>(2)(3)</sup>  |     | 615  |     | mVp-p  |
| V <sub>Tx-DIFF2-PP</sub>          | Output Voltage Differential Swing                            | Differential measurement with OUT <sub>n+</sub> and OUT <sub>n-</sub> , AC-Coupled and terminated by 50 Ω to GND, Inputs AC-Coupled, Measured with 8T Pattern at 12 Gbps <sup>(1)</sup><br>VID = 1000 mVp-p<br>VOD = Level 6 <sup>(2)(3)</sup> |     | 950  |     | mVp-p  |
| V <sub>Tx-DIFF3-PP</sub>          | Output Voltage Differential Swing                            | Differential measurement with OUT <sub>n+</sub> and OUT <sub>n-</sub> , AC-Coupled and terminated by 50 Ω to GND, Inputs AC-Coupled, Measured with 8T Pattern at 12 Gbps <sup>(1)</sup><br>VID = 1200 mVp-p<br>VOD = Level 6 <sup>(2)(3)</sup> |     | 1100 |     | mVp-p  |
| T <sub>PDEQ</sub>                 | Differential propagation delay                               | EQ = Level 1 to Level 4  |     | 80   |     | ps     |
| V <sub>Tx-CM-AC-P</sub>           | AC common mode voltage                                       | VOD = Level 6, 12 Gbps   |     | 20   |     | mV rms |
| V <sub>DISABLE-OUT</sub>          | Tx disable output voltage                                    | Driver disabled via PWDN   | -30 | 1    | 30  | mVp-p  |
| V <sub>OOB-IDLE</sub>             | OOB idle output voltage                                      | VID = 0 mVp-p  |     | 15   |     | mVp-p  |
| V <sub>OOB-OS-DELTA</sub>         | OOB offset delta   | OOB pattern, EQ = Level 1<br>VOD = Level 6   |     | 15   |     | mVp-p  |
| V <sub>OOB-CM-DELTA</sub>         | OOB common mode delta  | OOB pattern, EQ = Level 1<br>VOD = Level 6   |     | 11   |     | mVp-p  |
| T <sub>Tx-IDLE-SET-TO-IDLE</sub>  | Time to transition to idle after differential signal         | VID = 1.0 Vp-p, 1.5 Gbps   |     | 0.70 |     | ns     |
| T <sub>Tx-IDLE-TO-DIFF-DATA</sub> | Time to transition to valid differential signal after idle   | VID = 1.0 Vp-p, 1.5 Gbps   |     | 0.04 |     | ns     |

(1) 8T pattern is defined as a 1111111100000000'b pattern bit sequence.

(2) ATE measurements for production are tested at DC.

(3) In 40G-CR4/KR4/SAS/SATA/PCIe applications, the output VOD level is not fixed. It adjusts automatically based on the VID input amplitude level. The output VOD level set by VODA/B[1:0] depends on the VID level and the frequency content. The DS125BR820 repeater is designed to be transparent in this mode, so the Tx-FIR (de-emphasis) is passed to the Rx to support the handshake negotiation link training.

## Electrical Characteristics (continued)

| PARAMETER           |  | TEST CONDITIONS   | MIN | TYP  | MAX | UNIT   |
|---------------------|--|---|-----|------|-----|--------|
| R <sub>JADD</sub>   | Additive Random Jitter                   | Evaluation Module (EVM) Only, FR4, VID = 800 mVp-p, EQ = Level 1 PRBS15, 12 Gbps VOD = Level 6 All other channels active <sup>(4)</sup> |     | 0.36 |     | ps rms |
| <b>EQUALIZATION</b> |  |   |     |      |     |        |
| DJE1                | Residual deterministic jitter at 6 Gbps  | 5" Differential Stripline, 5mil trace width, FR4, VID = 800 mVp-p, PRBS15, EQ = Level 2, VOD = Level 6                                  |     | 0.06 |     | Ulp-p  |
| DJE2                | Residual deterministic jitter at 12 Gbps | 5" Differential Stripline, 5mil trace width, FR4, VID = 800 mVp-p, PRBS15, EQ = Level 2, VOD = Level 6                                  |     | 0.12 |     | Ulp-p  |

(4) Additive random jitter is given in RMS value by the following equation:  $R_{JADD} = \sqrt{[(\text{Output Jitter})^2 - (\text{Input Jitter})^2]}$ . Typical input jitter for these measurements is 150 fs rms.

## 6.6 Electrical Characteristics — Serial Bus Interface DC Specifications

Over recommended operating supply and temperature ranges unless other specified.

| PARAMETER           |   | TEST CONDITIONS                                     | MIN   | TYP  | MAX  | UNIT |
|---------------------|---|---|-------|------|------|------|
| V <sub>IL</sub>     | Data, Clock Input Low Voltage   |   |       |      | 0.8  | V    |
| V <sub>IH</sub>     | Data, Clock Input High Voltage  |   | 2.1   |      | 3.6  | V    |
| V <sub>OL</sub>     | Output Low Voltage  | SDA or SCL, I <sub>OL</sub> = 1.25 mA               | 0     |      | 0.36 | V    |
| V <sub>DD</sub>     | Nominal Bus Voltage   |   | 2.375 |      | 3.6  | V    |
| I <sub>IH-Pin</sub> | Input Leakage Per Device Pin  |   | +20   |      | +150 | μA   |
| I <sub>IL-Pin</sub> | Input Leakage Per Device Pin  |   | -160  |      | -40  | μA   |
| C <sub>I</sub>      | Capacitance for SDA and SCL   | See <sup>(1)(2)</sup>                               |       | < 5  |      | pF   |
| R <sub>TERM</sub>   | External Termination Resistance pull to V <sub>DD</sub> = 2.5 V ± 5% OR 3.3 V ± 10% | Pullup V <sub>DD</sub> = 3.3 V <sup>(1)(2)(3)</sup> |       | 2000 |      | Ω    |
|                     |   | Pullup V <sub>DD</sub> = 2.5 V <sup>(1)(2)(3)</sup> |       | 1000 |      | Ω    |

(1) Recommended value.

(2) Recommended maximum capacitance load per bus segment is 400 pF.

(3) Maximum termination voltage should be identical to the device supply voltage.

## 6.7 Serial Bus Interface Timing Specifications

| PARAMETER         |   | TEST CONDITIONS                                     | MIN | TYP | MAX  | UNIT |
|-------------------|---|---|-----|-----|------|------|
| F <sub>SMB</sub>  | Bus Operating Frequency   | ENSMB = VDD (Slave Mode)                            |     |     | 400  | kHz  |
|                   |   | ENSMB = FLOAT (Master Mode)                         | 280 | 400 | 520  | kHz  |
| t <sub>FALL</sub> | SCL or SDA Fall Time  | Read operation RPU = 4.7 kΩ, C <sub>b</sub> < 50 pF |     | 60  |      | ns   |
| t <sub>RISE</sub> | SCL or SDA Rise Time  | Read operation RPU = 4.7 kΩ, C <sub>b</sub> < 50 pF |     | 140 |      | ns   |
| t <sub>F</sub>    | Clock/Data Fall Time  | See <sup>(1)</sup>                                  |     |     | 300  | ns   |
| t <sub>R</sub>    | Clock/Data Rise Time  | See <sup>(1)</sup>                                  |     |     | 1000 | ns   |
| t <sub>POR</sub>  | Time in which a device must be operational after power-on reset | See <sup>(1)</sup>                                  |     |     | 500  | ms   |

(1) Compliant to SMBus 2.0 physical layer specification. See System Management Bus (SMBus) Specification Version 2.0, section 3.1.1 SMBus common AC specifications for details.

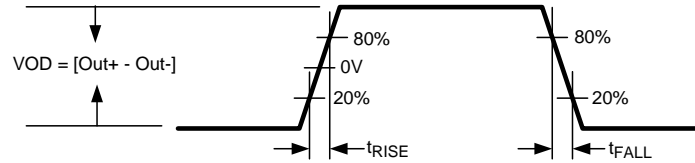

Figure 1. Output Rise And Fall Transition Time

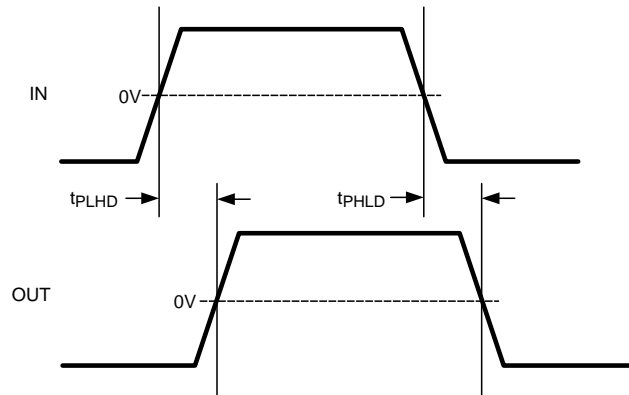

Figure 2. Propagation Delay Timing Diagram

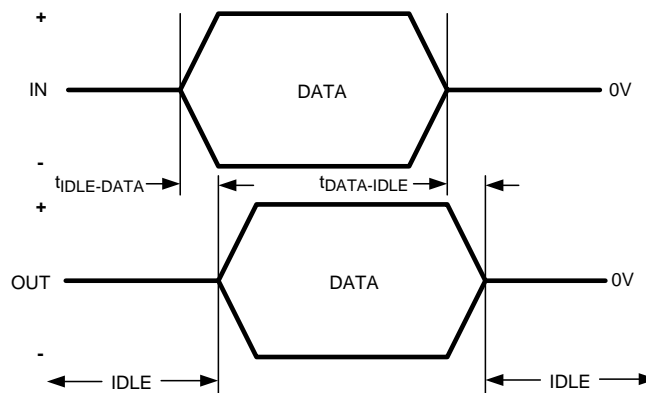

Figure 3. Transmit Idle-Data and Data-Idle Response Time

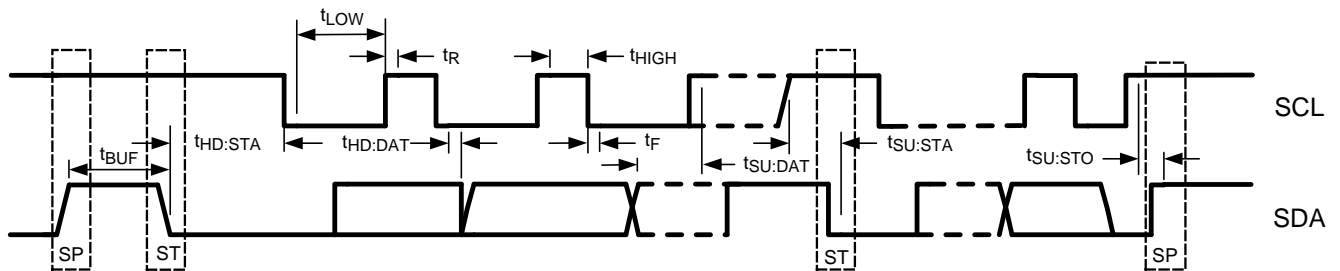
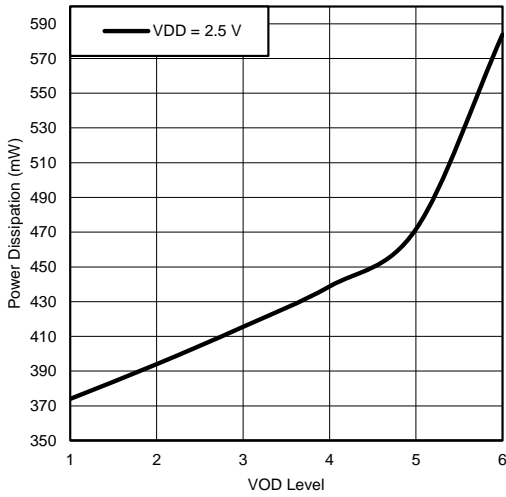

Figure 4. SMBus Timing Parameters

## 6.8 Typical Characteristics



**Test Conditions**  
 EQ Level 4  
 VOD\_DB 000'b  
 T 25°C

Figure 5. Typical Power Dissipation vs. VOD

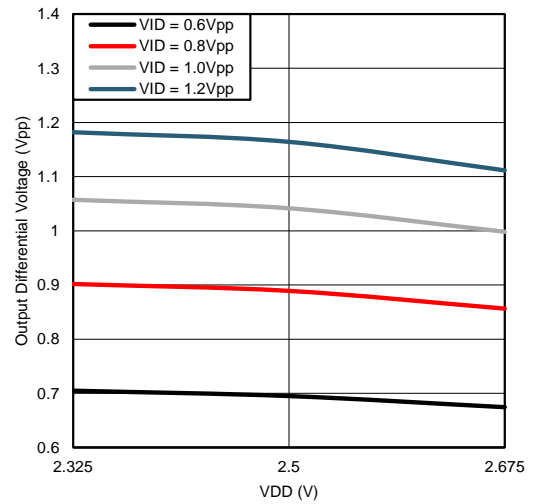

**Test Conditions**  
 Data Rate, Test Pattern 1.5625 Gbps, 1010 Pattern  
 VOD Level 6  
 EQ Level 1  
 T 25°C

Figure 6. Typical VOD vs. VDD

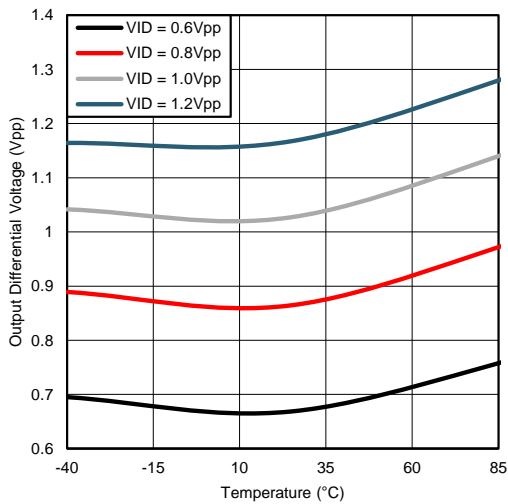

**Test Conditions**  
 Data Rate, Test Pattern 1.5625 Gbps, 1010 Pattern  
 VOD Level 6  
 EQ Level 1  
 VDD 2.5 V

Figure 7. Typical VOD vs. Temperature

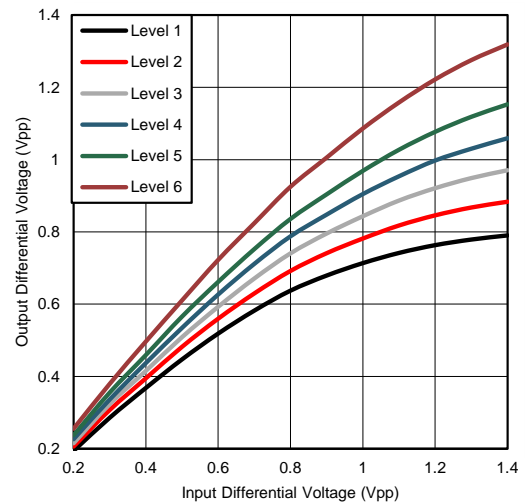

**Test Conditions**  
 Data Rate, Test Pattern 1.5625 Gbps, 1010 Pattern  
 EQ Level 1  
 T 25°C  
 VDD 2.5 V

Figure 8. Typical VOD vs. VID

## 7 Detailed Description

### 7.1 Overview

The DS125BR820 provides linear equalization for lossy printed circuit board backplanes and balanced cables. The DS125BR820 operates in three modes: Pin Control Mode (ENSMB = 0), SMBus Slave Mode (ENSMB = 1) and SMBus Master Mode (ENSMB = Float) to load register information from external EEPROM.

### 7.2 Functional Block Diagram

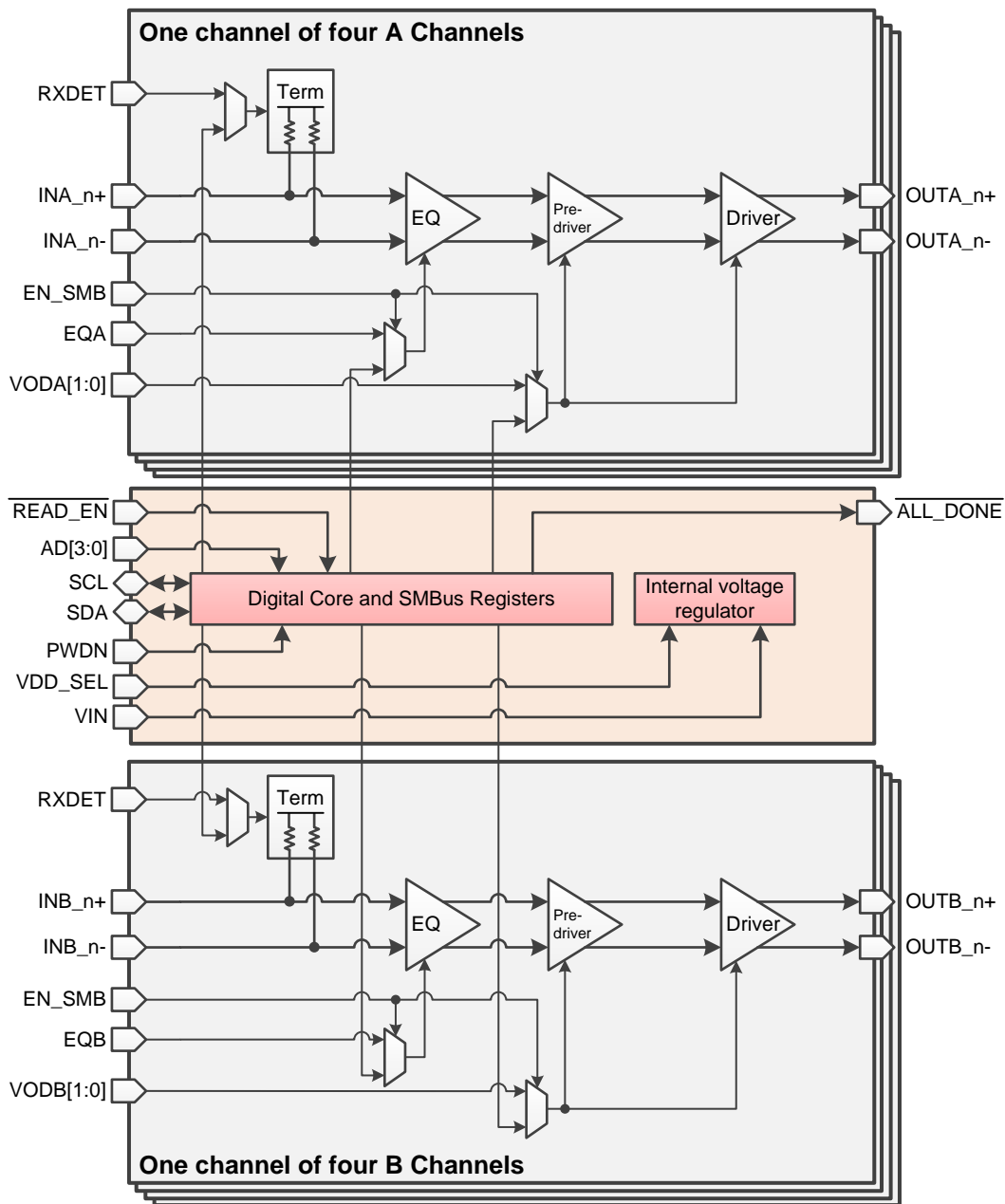

## Functional Block Diagram (continued)

### 7.2.1 Functional Datapath Blocks

In an increasing number of high speed applications, transparency between Tx and Rx endpoints is essential to ensure high signal integrity. The DS125BR820 channel datapath uses one input gain stage equalization coupled with a linear driver. This combination provides a high level of transparency, thereby achieving greater drive distance in applications such as 40G-CR4, 40G-KR4, SAS, SATA, and PCIe that require Rx-Tx auto-negotiation and link-training. Refer to the [Typical Applications](#) section for more application information regarding recommended settings and placement.

### 7.3 Feature Description

The 4-level input pins use a resistor divider to help set the four valid control levels and provide a wider range of control settings when ENSMB = 0. There is an internal 30 k $\Omega$  pull-up and a 60 k $\Omega$  pull-down connected to the package pin. These resistors, together with the external resistor connection, combine to achieve the desired voltage level. By using the 1 k $\Omega$  pull-down, 20 k $\Omega$  pull-down, no connect, and 1 k $\Omega$  pull-up, the optimal voltage levels for each of the four input states are achieved as shown in [Table 1](#).

**Table 1. 4-Level Control Pin Settings**

| LEVEL | SETTING                                  | RESULTING PIN VOLTAGE     |                           |
|-------|--|---------------------------|---------------------------|
|       |  | 3.3 V MODE                | 2.5 V MODE                |
| 0     | Tie 1 k $\Omega$ to GND                  | 0.10 V                    | 0.08 V                    |
| R     | Tie 20 k $\Omega$ to GND                 | $1/3 \times V_{IN}$       | $1/3 \times V_{DD}$       |
| F     | Float (leave pin open)                   | $2/3 \times V_{IN}$       | $2/3 \times V_{DD}$       |
| 1     | Tie 1 k $\Omega$ to $V_{IN}$ or $V_{DD}$ | $V_{IN} - 0.05 \text{ V}$ | $V_{DD} - 0.04 \text{ V}$ |

#### Typical 4-Level Input Thresholds

- Internal Threshold between 0 and R =  $0.2 \times V_{IN}$  or  $V_{DD}$
- Internal Threshold between R and F =  $0.5 \times V_{IN}$  or  $V_{DD}$
- Internal Threshold between F and 1 =  $0.8 \times V_{IN}$  or  $V_{DD}$

In order to minimize the startup current associated with the integrated 2.5 V regulator, the 1 k $\Omega$  pull-up / pull-down resistors are recommended. If several four level inputs require the same setting, it is possible to combine two or more 1 k $\Omega$  resistors into a single lower value resistor. As an example, combining two inputs with a single 500  $\Omega$  resistor is a valid way to save board space.

### 7.4 Device Functional Modes

#### 7.4.1 Pin Control Mode:

When in Pin Mode (ENSMB = 0), equalization and VOD (output amplitude) can be selected via pin control for both the A-channels and B-channels per [Table 4](#). The RXDET pin provides either automatic or manual control for input termination (50  $\Omega$  or > 50 k $\Omega$  to VDD). The receiver electrical signal detect status threshold is adjustable via the SD\_TH pin. By setting signal-detect threshold level via the SD\_TH pin, status information about a valid signal detect assert/de-assert can be read back via SMBus registers. Pin control mode is ideal in situations where neither MCU or EEPROM is available to access the device via SMBus SDA/SCL lines.

#### 7.4.2 Slave SMBus Mode:

When in Slave SMBus Mode (ENSMB = 1), the VOD (output amplitude), equalization, and termination disable features are all programmable on an individual channel basis, rather than in collective A-channel and B-channel groups. Upon assertion of ENSMB, the EQx and VODx settings are controlled by SMBus immediately. It is important to note that SMBus settings can only be changed from their defaults after asserting Register Enable by setting Reg 0x06[3] = 1. The EQx and VODx pins are subsequently converted to AD0-AD3 SMBus address inputs. The other external control pins (RXDET and SD\_TH) remain active unless their respective registers are written to and the appropriate override bit is set. If the user overrides a pin control, the input voltage level of that control pin is ignored until ENSMB is driven low (Pin Mode). In the event that channels are powered down via the PWDN pin, the state of all register settings are not affected.

**Device Functional Modes (continued)**
**Table 2. Rx Detect Settings**

| PWDN <sup>(1)</sup><br>(Pin 52) | RXDET<br>(Pin 22) | SMBus REG<br>Bit[3:2] | INPUT<br>TERMINATION                  | RECOMMENDED<br>USE              | COMMENTS   |
|---------------------------------|-------------------|-----------------------|---------------------------------------|---------------------------------|--|
| 0                               | 0                 | 00                    | Hi-Z                                  |                                 | Manual Rx-Detect, input is Hi-Z  |
| 0                               | R                 | 01                    | Pre Detect: Hi-Z<br>Post Detect: 50 Ω | PCIe Only                       | Auto Rx-Detect, outputs test every 12 ms for 600 ms then stops; termination is Hi-Z until Rx detection; once detected input termination is 50 Ω. Reset function by pulsing PWDN high for 5 μs then low again |
| 0                               | F<br>(Default)    | 10                    | Pre Detect: Hi-Z<br>Post Detect: 50 Ω | PCIe Only                       | Auto Rx-Detect, outputs test every 12 ms until detection occurs; termination is Hi-Z until Rx detection; once detected input termination is 50 Ω   |
| 0                               | 1                 | 11                    | 50 Ω                                  | 40G-<br>CR4/SR4/LR4<br>SAS/SATA | Manual Rx-Detect, input is 50 Ω. For 40G-CR4/SR4/LR4/SAS/SATA applications, it is required to use this setting.  |
| 1                               | X                 | X                     | Hi-Z                                  |                                 | Power Down mode, input is Hi-Z, output drivers are disabled<br>Used to reset Rx-Detect State Machine when held high for 5 μs   |

(1) In SMBus Slave Mode, the Rx Detect State Machine can be manually reset in software by overriding the device  $\overline{\text{PRSNT}}$  function. This is accomplished by setting the Override  $\overline{\text{PRSNT}}$  bit (Reg 0x02[7]) and then toggling the  $\overline{\text{PRSNT}}$  value bit (Reg 0x02[6]). See [Table 9](#) for more information about resetting the Rx Detect State Machine.

**Table 3. Signal Detect Status Threshold Level<sup>(1)(2)</sup>**

| LEVEL | SD_TH<br>(Pin 26) | SMBus REG BIT[3:2]<br>and[1:0] | [3:2] ASSERT LEVEL<br>(mVp-p) |         | [1:0] DE-ASSERT LEVEL<br>(mVp-p) |         |
|-------|-------------------|--------------------------------|-------------------------------|---------|----------------------------------|---------|
|       |                   |                                | 3 Gbps                        | 12 Gbps | 3 Gbps                           | 12 Gbps |
| 1     | 0                 | 10                             | 18                            | 75      | 14                               | 55      |
| 2     | R                 | 01                             | 12                            | 40      | 8                                | 22      |
| 3     | F (default)       | 00                             | 15                            | 50      | 11                               | 37      |
| 4     | 1                 | 11                             | 16                            | 58      | 12                               | 45      |

(1) VDD = 2.5 V, 25°C, 11 00 11 00 pattern at 3 Gbps and 101010 pattern at 12 Gbps

(2) Signal detect status threshold sets the value at which a signal detect status is flagged via SMBus Reg 0x0A. Regardless of the threshold level, the output always remains enabled unless manually powered down.

### 7.4.3 SMBus Master Mode

When in SMBus Master Mode (ENSMB = Float), the VOD (output amplitude), equalization, and termination disable features for multiple devices can be loaded via external EEPROM. By asserting a Float condition on the ENSMB pin, an external EEPROM writes register settings to each device in accordance with its SMBus slave address. The settings programmable by external EEPROM provide only a subset of all the register bits available via SMBus Slave Mode, and the bit-mapping between SMBus Slave Mode registers and Master SMBus registers can be referenced in [Table 6](#). Once the EEPROM successfully finishes loading each device's register settings, the device reverts back to SMBus Slave Mode and releases SDA/SCL control to an external master MCU. If the EEPROM fails to load settings to a particular device, for example due to an invalid or blank hex file, a time-out occurs and the device hangs in an unknown state.

## 7.5 Signal Conditioning Settings

Equalization and VOD settings accessible via the pin controls are chosen to meet the needs of most high speed applications. These settings can also be controlled via the SMBus registers. Each pin input has a total of four possible voltage level settings. [Table 4](#) and [Table 5](#) show both the Pin Mode and SMBus Mode settings that are used in order to program the equalization and VOD gain for each DS125BR820 channel.

**Signal Conditioning Settings (continued)**
**Table 4. Equalizer Settings<sup>(1)(2)</sup>**

| EQUALIZATION BOOST RELATIVE to DC |                           |                  |                  |                  |                |                |                |
|-----------------------------------|---------------------------|------------------|------------------|------------------|----------------|----------------|----------------|
| LEVEL                             | EQA <sup>(3)</sup><br>EQB | EQ – 8 bits[7:0] | dB at<br>1.5 GHz | dB at<br>2.5 GHz | dB at<br>4 GHz | dB at<br>5 GHz | dB at<br>6 GHz |
| 1                                 | 0                         | xxxx xx00 = 0x00 | 2.1              | 2.5              | 2.7            | 2.9            | 3.0            |
| 2                                 | R                         | xxxx xx01 = 0x01 | 4.0              | 5.1              | 6.4            | 6.8            | 7.4            |
| 3                                 | F                         | xxxx xx10 = 0x02 | 5.5              | 7.0              | 8.3            | 8.6            | 8.9            |
| 4                                 | 1                         | xxxx xx11 = 0x03 | 6.8              | 8.3              | 9.5            | 9.6            | 9.8            |

- (1) Optimal EQ setting should be determined via simulation and prototype verification.  
 (2) Equalization boost values are inclusive of package loss.  
 (3) To program EQ Level 1-4 correctly in Pin Mode, RESERVED3 and AD2 pins must be tied via 1 kΩ resistor to GND.

**Table 5. Output Voltage Settings<sup>(1)</sup>**

| LEVEL | VODA1<br>VODB1 | VODA0<br>VODB0 | VOD - 3 bits[2:0] | VOD_DB - 3<br>bits[2:0] | VID V <sub>p-p</sub> | VOD/VID Ratio <sup>(1)</sup> |
|-------|----------------|----------------|-------------------|-------------------------|----------------------|------------------------------|
| --    | --             | --             | 000'b             | 000'b                   | 1.2                  | 0.57 <sup>(2)</sup>          |
| 1     | 0              | 0              | 001'b             | 000'b                   | 1.2                  | 0.65                         |
| 2     | 0              | R              | 010'b             | 000'b                   | 1.2                  | 0.71                         |
| 3     | 0              | 1              | 011'b             | 000'b                   | 1.2                  | 0.77                         |
| 4     | R              | F              | 100'b             | 000'b                   | 1.2                  | 0.83                         |
| 5     | F              | R              | 101'b             | 000'b                   | 1.2                  | 0.90                         |
| 6     | 1              | 0              | 110'b             | 000'b                   | 1.2                  | 1.00                         |
| --    | --             | --             | 111'b             | 000'b                   | 1.2                  | 1.04 <sup>(2)(3)</sup>       |

- (1) For 40G-CR4/KR4/SAS/SATA/PCIe operation, it is important to keep the output amplitude and dynamic range as large as possible. When operating in Pin Mode, it is recommended to use VODA[1:0] = VODB[1:0] = Level 6. In SMBus Mode, it is also recommended to use Level 6 (that is, VOD = 110'b and VOD\_DB = 000'b).  
 (2) These VOD settings are only accessible via SMBus Modes.  
 (3) VOD = 111'b setting in SMBus Mode is not recommended.



**Table 6. EEPROM Register Map - Single Device With Default Value**

| EEPROM Address Byte |      | Bit 7                    | Bit 6                    | Bit 5                    | Bit 4                    | Bit 3                    | Bit 2                    | Bit 1                    | Bit 0                    |
|---------------------|------|--------------------------|--------------------------|--------------------------|--------------------------|--------------------------|--------------------------|--------------------------|--------------------------|
| Description         | 0x00 | CRC_EN                   | Address Map Present      | EEPROM > 256 Bytes       | Reserved                 | DEVICE COUNT[3]          | DEVICE COUNT[2]          | DEVICE COUNT[1]          | DEVICE COUNT[0]          |
| Default Value       |      | 0                        | 0                        | 0                        | 0                        | 0                        | 0                        | 0                        | 0                        |
| Description         | 0x01 | Reserved                 | Reserved                 | Reserved                 | Reserved                 | Reserved                 | Reserved                 | Reserved                 | Reserved                 |
| Default Value       |      | 0                        | 0                        | 0                        | 0                        | 0                        | 0                        | 0                        | 0                        |
| Description         | 0x02 | Max EEPROM Burst size[7] | Max EEPROM Burst size[6] | Max EEPROM Burst size[5] | Max EEPROM Burst size[4] | Max EEPROM Burst size[3] | Max EEPROM Burst size[2] | Max EEPROM Burst size[1] | Max EEPROM Burst size[0] |
| Default Value       |      | 0                        | 0                        | 0                        | 0                        | 0                        | 0                        | 0                        | 0                        |
| Description         | 0x03 | PWDN_CH7                 | PWDN_CH6                 | PWDN_CH5                 | PWDN_CH4                 | PWDN_CH3                 | PWDN_CH2                 | PWDN_CH1                 | PWDN_CH0                 |
| SMBus Register      |      | 0x01[7]                  | 0x01[6]                  | 0x01[5]                  | 0x01[4]                  | 0x01[3]                  | 0x01[2]                  | 0x01[1]                  | 0x01[0]                  |
| Default Value       |      | 0                        | 0                        | 0                        | 0                        | 0                        | 0                        | 0                        | 0                        |
| Description         | 0x04 | Reserved                 | Reserved                 | Reserved                 | Reserved                 | Ovrd_PWDN                | Reserved                 | Reserved                 | Reserved                 |
| SMBus Register      |      | 0x02[5]                  | 0x02[4]                  | 0x02[3]                  | 0x02[2]                  | 0x02[0]                  | 0x04[7]                  | 0x04[6]                  | 0x04[5]                  |
| Default Value       |      | 0                        | 0                        | 0                        | 0                        | 0                        | 0                        | 0                        | 0                        |
| Description         | 0x05 | Reserved                 | Reserved                 | Reserved                 | Reserved                 | Reserved                 | Reserved                 | Ovrd_SD_TH               | Reserved                 |
| SMBus Register      |      | 0x04[4]                  | 0x04[3]                  | 0x04[2]                  | 0x04[1]                  | 0x04[0]                  | 0x06[4]                  | 0x08[6]                  | 0x08[5]                  |
| Default Value       |      | 0                        | 0                        | 0                        | 0                        | 0                        | 1                        | 0                        | 0                        |
| Description         | 0x06 | Reserved                 | Ovrd_RXDET               | Reserved                 | Reserved                 | Reserved                 | Reserved                 | Reserved                 | Reserved                 |
| SMBus Register      |      | 0x08[4]                  | 0x08[3]                  | 0x08[2]                  | 0x08[1]                  | 0x08[0]                  | 0x0B[6]                  | 0x0B[5]                  | 0x0B[4]                  |
| Default Value       |      | 0                        | 0                        | 0                        | 0                        | 0                        | 1                        | 1                        | 1                        |
| Description         | 0x07 | Reserved                 | Reserved                 | Reserved                 | Reserved                 | Reserved                 | Reserved                 | CH0_RXDET_1              | CH0_RXDET_0              |
| SMBus Register      |      | 0x0B[3]                  | 0x0B[2]                  | 0x0B[1]                  | 0x0B[0]                  | 0x0E[5]                  | 0x0E[4]                  | 0x0E[3]                  | 0x0E[2]                  |
| Default Value       |      | 0                        | 0                        | 0                        | 0                        | 0                        | 0                        | 0                        | 0                        |
| Description         | 0x08 | Reserved                 | Reserved                 | Reserved                 | Reserved                 | Reserved                 | Reserved                 | CH0_EQ_1                 | CH0_EQ_0                 |
| SMBus Register      |      | 0x0F[7]                  | 0x0F[6]                  | 0x0F[5]                  | 0x0F[4]                  | 0x0F[3]                  | 0x0F[2]                  | 0x0F[1]                  | 0x0F[0]                  |
| Default Value       |      | 0                        | 0                        | 1                        | 0                        | 1                        | 1                        | 1                        | 1                        |

**Table 6. EEPROM Register Map - Single Device With Default Value (continued)**

| EEPROM Address Byte |      | Bit 7        | Bit 6        | Bit 5        | Bit 4       | Bit 3        | Bit 2        | Bit 1        | Bit 0       |
|---------------------|------|--------------|--------------|--------------|-------------|--------------|--------------|--------------|-------------|
| Description         | 0x09 | CH0_SCP      | Reserved     | Reserved     | Reserved    | Reserved     | CH0_VOD_2    | CH0_VOD_1    | CH0_VOD_0   |
| SMBus Register      |      | 0x10[7]      | 0x10[6]      | 0x10[5]      | 0x10[4]     | 0x10[3]      | 0x10[2]      | 0x10[1]      | 0x10[0]     |
| Default Value       |      | 0xAD         | 1            | 0            | 1           | 0            | 1            | 1            | 0           |
| Description         | 0x0A | CH0_VOD_DB_2 | CH0_VOD_DB_1 | CH0_VOD_DB_0 | Reserved    | CH0_THa_1    | CH0_THa_0    | CH0_THd_1    | CH0_THd_0   |
| SMBus Register      |      | 0x11[2]      | 0x11[1]      | 0x11[0]      | 0x12[7]     | 0x12[3]      | 0x12[2]      | 0x12[1]      | 0x12[0]     |
| Default Value       |      | 0x40         | 0            | 1            | 0           | 0            | 0            | 0            | 0           |
| Description         | 0x0B | Reserved     | Reserved     | CH1_RXDET_1  | CH1_RXDET_0 | Reserved     | Reserved     | Reserved     | Reserved    |
| SMBus Register      |      | 0x15[5]      | 0x15[4]      | 0x15[3]      | 0x15[2]     | 0x16[7]      | 0x16[6]      | 0x16[5]      | 0x16[4]     |
| Default Value       |      | 0x02         | 0            | 0            | 0           | 0            | 0            | 1            | 0           |
| Description         | 0x0C | Reserved     | Reserved     | CH1_EQ_1     | CH1_EQ_0    | CH1_SCP      | Reserved     | Reserved     | Reserved    |
| SMBus Register      |      | 0x16[3]      | 0x16[2]      | 0x16[1]      | 0x16[0]     | 0x17[7]      | 0x17[6]      | 0x17[5]      | 0x17[4]     |
| Default Value       |      | 0xFA         | 1            | 1            | 1           | 1            | 1            | 0            | 1           |
| Description         | 0x0D | Reserved     | CH1_VOD_2    | CH1_VOD_1    | CH1_VOD_0   | CH1_VOD_DB_2 | CH1_VOD_DB_1 | CH1_VOD_DB_0 | Reserved    |
| SMBus Register      |      | 0x17[3]      | 0x17[2]      | 0x17[1]      | 0x17[0]     | 0x18[2]      | 0x18[1]      | 0x18[0]      | 0x19[7]     |
| Default Value       |      | 0xD4         | 1            | 1            | 0           | 1            | 0            | 1            | 0           |
| Description         | 0x0E | CH1_THa_1    | CH1_THa_0    | CH1_THd_1    | CH1_THd_0   | Reserved     | Reserved     | CH2_RXDET_1  | CH2_RXDET_0 |
| SMBus Register      |      | 0x19[3]      | 0x19[2]      | 0x19[1]      | 0x19[0]     | 0x1C[5]      | 0x1C[4]      | 0x1C[3]      | 0x1C[2]     |
| Default Value       |      | 0x00         | 0            | 0            | 0           | 0            | 0            | 0            | 0           |
| Description         | 0x0F | Reserved     | Reserved     | Reserved     | Reserved    | Reserved     | Reserved     | CH2_EQ_1     | CH2_EQ_0    |
| SMBus Register      |      | 0x1D[7]      | 0x1D[6]      | 0x1D[5]      | 0x1D[4]     | 0x1D[3]      | 0x1D[2]      | 0x1D[1]      | 0x1D[0]     |
| Default Value       |      | 0x2F         | 0            | 0            | 1           | 0            | 1            | 1            | 1           |
| Description         | 0x10 | CH2_SCP      | Reserved     | Reserved     | Reserved    | Reserved     | CH2_VOD_2    | CH2_VOD_1    | CH2_VOD_0   |
| SMBus Register      |      | 0x1E[7]      | 0x1E[6]      | 0x1E[5]      | 0x1E[4]     | 0x1E[3]      | 0x1E[2]      | 0x1E[1]      | 0x1E[0]     |
| Default Value       |      | 0xAD         | 1            | 0            | 1           | 0            | 1            | 1            | 0           |

**Table 6. EEPROM Register Map - Single Device With Default Value (continued)**

| EEPROM Address Byte |      | Bit 7         | Bit 6            | Bit 5            | Bit 4       | Bit 3        | Bit 2            | Bit 1            | Bit 0         |
|---------------------|------|---------------|------------------|------------------|-------------|--------------|------------------|------------------|---------------|
| Description         | 0x11 | CH2_VOD_DB_2  | CH2_VOD_DB_1     | CH2_VOD_DB_0     | Reserved    | CH2_THa_1    | CH2_THa_0        | CH2_THd_1        | CH2_THd_0     |
| SMBus Register      |      | 0x1F[2]       | 0x1F[1]          | 0x1F[0]          | 0x20[7]     | 0x20[3]      | 0x20[2]          | 0x20[1]          | 0x20[0]       |
| Default Value       |      | 0             | 1                | 0                | 0           | 0            | 0                | 0                | 0             |
| Description         | 0x12 | Reserved      | Reserved         | CH3_RXDET_1      | CH3_RXDET_0 | Reserved     | Reserved         | Reserved         | Reserved      |
| SMBus Register      |      | 0x23[5]       | 0x23[4]          | 0x23[3]          | 0x23[2]     | 0x24[7]      | 0x24[6]          | 0x24[5]          | 0x24[4]       |
| Default Value       |      | 0             | 0                | 0                | 0           | 0            | 0                | 1                | 0             |
| Description         | 0x13 | Reserved      | Reserved         | CH3_EQ_1         | CH3_EQ_0    | CH3_SCP      | Reserved         | Reserved         | Reserved      |
| SMBus Register      |      | 0x24[3]       | 0x24[2]          | 0x24[1]          | 0x24[0]     | 0x25[7]      | 0x25[6]          | 0x25[5]          | 0x25[4]       |
| Default Value       |      | 1             | 1                | 1                | 1           | 1            | 0                | 1                | 0             |
| Description         | 0x14 | Reserved      | CH3_VOD_2        | CH3_VOD_1        | CH3_VOD_0   | CH3_VOD_DB_2 | CH3_VOD_DB_1     | CH3_VOD_DB_0     | Reserved      |
| SMBus Register      |      | 0x25[3]       | 0x25[2]          | 0x25[1]          | 0x25[0]     | 0x26[2]      | 0x26[1]          | 0x26[0]          | 0x27[7]       |
| Default Value       |      | 1             | 1                | 0                | 1           | 0            | 1                | 0                | 0             |
| Description         | 0x15 | CH3_THa_1     | CH3_THa_0        | CH3_THd_1        | CH3_THd_0   | Reserved     | hi_idle_SD CH0-3 | hi_idle_SD CH4-7 | fast_SD CH0-3 |
| SMBus Register      |      | 0x27[3]       | 0x27[2]          | 0x27[1]          | 0x27[0]     | 0x28[6]      | 0x28[5]          | 0x28[4]          | 0x28[3]       |
| Default Value       |      | 0             | 0                | 0                | 0           | 1            | 0                | 0                | 1             |
| Description         | 0x16 | fast_SD CH4-7 | lo_gain_SD CH0-3 | lo_gain_SD CH4-7 | Reserved    | Reserved     | CH4_RXDET_1      | CH4_RXDET_0      | Reserved      |
| SMBus Register      |      | 0x28[2]       | 0x28[1]          | 0x28[0]          | 0x2B[5]     | 0x2B[4]      | 0x2B[3]          | 0x2B[2]          | 0x2C[7]       |
| Default Value       |      | 1             | 0                | 0                | 0           | 0            | 0                | 0                | 0             |
| Description         | 0x17 | Reserved      | Reserved         | Reserved         | Reserved    | Reserved     | CH4_EQ_1         | CH4_EQ_0         | CH4_SCP       |
| SMBus Register      |      | 0x2C[6]       | 0x2C[5]          | 0x2C[4]          | 0x2C[3]     | 0x2C[2]      | 0x2C[1]          | 0x2C[0]          | 0x2D[7]       |
| Default Value       |      | 0             | 1                | 0                | 1           | 1            | 1                | 1                | 1             |
| Description         | 0x18 | Reserved      | Reserved         | Reserved         | Reserved    | CH4_VOD_2    | CH4_VOD_1        | CH4_VOD_0        | CH4_VOD_DB_2  |
| SMBus Register      |      | 0x2D[6]       | 0x2D[5]          | 0x2D[4]          | 0x2D[3]     | 0x2D[2]      | 0x2D[1]          | 0x2D[0]          | 0x2E[2]       |
| Default Value       |      | 0             | 1                | 0                | 1           | 1            | 0                | 1                | 0             |

**Table 6. EEPROM Register Map - Single Device With Default Value (continued)**

| EEPROM Address Byte |      | Bit 7        | Bit 6        | Bit 5       | Bit 4        | Bit 3        | Bit 2        | Bit 1       | Bit 0        |
|---------------------|------|--------------|--------------|-------------|--------------|--------------|--------------|-------------|--------------|
| Description         | 0x19 | CH4_VOD_DB_1 | CH4_VOD_DB_0 | Reserved    | CH4_THa_1    | CH4_THa_0    | CH4_THd_1    | CH4_THd_0   | Reserved     |
| SMBus Register      |      | 0x2E[1]      | 0x2E[0]      | 0x2F[7]     | 0x2F[3]      | 0x2F[2]      | 0x2F[1]      | 0x2F[0]     | 0x32[5]      |
| Default Value       |      | 0x80         | 1            | 0           | 0            | 0            | 0            | 0           | 0            |
| Description         | 0x1A | Reserved     | CH5_RXDET_1  | CH5_RXDET_0 | Reserved     | Reserved     | Reserved     | Reserved    | Reserved     |
| SMBus Register      |      | 0x32[4]      | 0x32[3]      | 0x32[2]     | 0x33[7]      | 0x33[6]      | 0x33[5]      | 0x33[4]     | 0x33[3]      |
| Default Value       |      | 0x05         | 0            | 0           | 0            | 0            | 0            | 1           | 0            |
| Description         | 0x1B | Reserved     | CH5_EQ_1     | CH5_EQ_0    | CH5_SCP      | Reserved     | Reserved     | Reserved    | Reserved     |
| SMBus Register      |      | 0x33[2]      | 0x33[1]      | 0x33[0]     | 0x34[7]      | 0x34[6]      | 0x34[5]      | 0x34[4]     | 0x34[3]      |
| Default Value       |      | 0xF5         | 1            | 1           | 1            | 1            | 0            | 1           | 0            |
| Description         | 0x1C | CH5_VOD_2    | CH5_VOD_1    | CH5_VOD_0   | CH5_VOD_DB_2 | CH5_VOD_DB_1 | CH5_VOD_DB_0 | Reserved    | CH5_THa_1    |
| SMBus Register      |      | 0x34[2]      | 0x34[1]      | 0x34[0]     | 0x35[2]      | 0x35[1]      | 0x35[0]      | 0x36[7]     | 0x36[3]      |
| Default Value       |      | 0xA8         | 1            | 0           | 1            | 0            | 1            | 0           | 0            |
| Description         | 0x1D | CH5_THa_0    | CH5_THd_1    | CH5_THd_0   | Reserved     | Reserved     | CH6_RXDET_1  | CH6_RXDET_0 | Reserved     |
| SMBus Register      |      | 0x36[2]      | 0x36[1]      | 0x36[0]     | 0x39[5]      | 0x39[4]      | 0x39[3]      | 0x39[2]     | 0x3A[7]      |
| Default Value       |      | 0x00         | 0            | 0           | 0            | 0            | 0            | 0           | 0            |
| Description         | 0x1E | Reserved     | Reserved     | Reserved    | Reserved     | Reserved     | CH6_EQ_1     | CH6_EQ_0    | CH6_SCP      |
| SMBus Register      |      | 0x3A[6]      | 0x3A[5]      | 0x3A[4]     | 0x3A[3]      | 0x3A[2]      | 0x3A[1]      | 0x3A[0]     | 0x3B[7]      |
| Default Value       |      | 0x5F         | 0            | 1           | 0            | 1            | 1            | 1           | 1            |
| Description         | 0x1F | Reserved     | Reserved     | Reserved    | Reserved     | CH6_VOD_2    | CH6_VOD_1    | CH6_VOD_0   | CH6_VOD_DB_2 |
| SMBus Register      |      | 0x3B[6]      | 0x3B[5]      | 0x3B[4]     | 0x3B[3]      | 0x3B[2]      | 0x3B[1]      | 0x3B[0]     | 0x3C[2]      |
| Default Value       |      | 0x5A         | 0            | 1           | 0            | 1            | 1            | 0           | 1            |
| Description         | 0x20 | CH6_VOD_DB_1 | CH6_VOD_DB_0 | Reserved    | CH6_THa_1    | CH6_THa_0    | CH6_THd_1    | CH6_THd_0   | Reserved     |
| SMBus Register      |      | 0x3C[1]      | 0x3C[0]      | 0x3D[7]     | 0x3D[3]      | 0x3D[2]      | 0x3D[1]      | 0x3D[0]     | 0x40[5]      |
| Default Value       |      | 0x80         | 1            | 0           | 0            | 0            | 0            | 0           | 0            |

**Table 6. EEPROM Register Map - Single Device With Default Value (continued)**

| EEPROM Address Byte |      | Bit 7     | Bit 6       | Bit 5       | Bit 4        | Bit 3        | Bit 2        | Bit 1    | Bit 0     |
|---------------------|------|-----------|-------------|-------------|--------------|--------------|--------------|----------|-----------|
| Description         | 0x21 | Reserved  | CH7_RXDET_1 | CH7_RXDET_0 | Reserved     | Reserved     | Reserved     | Reserved | Reserved  |
| SMBus Register      |      | 0x40[4]   | 0x40[3]     | 0x40[2]     | 0x41[7]      | 0x41[6]      | 0x41[5]      | 0x41[4]  | 0x41[3]   |
| Default Value       |      | 0         | 0           | 0           | 0            | 0            | 1            | 0        | 1         |
| <hr/>               |      |           |             |             |              |              |              |          |           |
| Description         | 0x22 | Reserved  | CH7_EQ_1    | CH7_EQ_0    | CH7_SCP      | Reserved     | Reserved     | Reserved | Reserved  |
| SMBus Register      |      | 0x41[2]   | 0x41[1]     | 0x41[0]     | 0x42[7]      | 0x42[6]      | 0x42[5]      | 0x42[4]  | 0x42[3]   |
| Default Value       |      | 1         | 1           | 1           | 1            | 0            | 1            | 0        | 1         |
| <hr/>               |      |           |             |             |              |              |              |          |           |
| Description         | 0x23 | CH7_VOD_2 | CH7_VOD_1   | CH7_VOD_0   | CH7_VOD_DB_2 | CH7_VOD_DB_1 | CH7_VOD_DB_0 | Reserved | CH7_THa_1 |
| SMBus Register      |      | 0x42[2]   | 0x42[1]     | 0x42[0]     | 0x43[2]      | 0x43[1]      | 0x43[0]      | 0x44[7]  | 0x44[3]   |
| Default Value       |      | 1         | 0           | 1           | 0            | 1            | 0            | 0        | 0         |
| <hr/>               |      |           |             |             |              |              |              |          |           |
| Description         | 0x24 | CH7_THa_0 | CH7_THd_1   | CH7_THd_0   | Reserved     | Reserved     | Reserved     | Reserved | Reserved  |
| SMBus Register      |      | 0x44[2]   | 0x44[1]     | 0x44[0]     | 0x47[3]      | 0x47[2]      | 0x47[1]      | 0x47[0]  | 0x48[7]   |
| Default Value       |      | 0         | 0           | 0           | 0            | 0            | 0            | 0        | 0         |
| <hr/>               |      |           |             |             |              |              |              |          |           |
| Description         | 0x25 | Reserved  | Reserved    | Reserved    | Reserved     | Reserved     | Reserved     | Reserved | Reserved  |
| SMBus Register      |      | 0x48[6]   | 0x4C[7]     | 0x4C[6]     | 0x4C[5]      | 0x4C[4]      | 0x4C[3]      | 0x4C[0]  | 0x59[0]   |
| Default Value       |      | 0         | 0           | 0           | 0            | 0            | 0            | 0        | 0         |
| <hr/>               |      |           |             |             |              |              |              |          |           |
| Description         | 0x26 | Reserved  | Reserved    | Reserved    | Reserved     | Reserved     | Reserved     | Reserved | Reserved  |
| SMBus Register      |      | 0x5A[7]   | 0x5A[6]     | 0x5A[5]     | 0x5A[4]      | 0x5A[3]      | 0x5A[2]      | 0x5A[1]  | 0x5A[0]   |
| Default Value       |      | 0         | 1           | 0           | 1            | 0            | 1            | 0        | 0         |
| <hr/>               |      |           |             |             |              |              |              |          |           |
| Description         | 0x27 | Reserved  | Reserved    | Reserved    | Reserved     | Reserved     | Reserved     | Reserved | Reserved  |
| SMBus Register      |      | 0x5B[7]   | 0x5B[6]     | 0x5B[5]     | 0x5B[4]      | 0x5B[3]      | 0x5B[2]      | 0x5B[1]  | 0x5B[0]   |
| Default Value       |      | 0         | 1           | 0           | 1            | 0            | 1            | 0        | 0         |

**Table 7. Example Of EEPROM for Four Devices Using Two Address Maps**

| EEPROM ADDRESS | ADDRESS (Hex) | EEPROM DATA | COMMENTS   |
|----------------|---------------|-------------|--|
| 0              | 00            | 0x43        | CRC_EN = 0, Address Map = 1, >256 bytes = 0, Device Count[3:0] = 3 |
| 1              | 01            | 0x00        |  |
| 2              | 02            | 0x10        | EEPROM Burst Size  |
| 3              | 03            | 0x00        | CRC not used   |
| 4              | 04            | 0x0B        | Device 0 Address Location  |
| 5              | 05            | 0x00        | CRC not used   |
| 6              | 06            | 0x0B        | Device 1 Address Location  |
| 7              | 07            | 0x00        | CRC not used   |
| 8              | 08            | 0x30        | Device 2 Address Location  |
| 9              | 09            | 0x00        | CRC not used   |
| 10             | 0A            | 0x30        | Device 3 Address Location  |
| 11             | 0B            | 0x00        | Begin Device 0, 1 - Address Offset 3                               |
| 12             | 0C            | 0x00        |  |
| 13             | 0D            | 0x04        |  |
| 14             | 0E            | 0x07        |  |
| 15             | 0F            | 0x00        |  |
| 16             | 10            | 0x01        | EQ CHB0 = 0x01   |
| 17             | 11            | 0xAD        | VOD CHB0 = 101'b   |
| 18             | 12            | 0x00        | VOD_DB CHB0 = 000'b  |
| 19             | 13            | 0x00        |  |
| 20             | 14            | 0x1A        | EQ CHB1 = 0x01   |
| 21             | 15            | 0xD0        | VOD CHB1 = 101'b, VOD_DB CHB1 = 000'b                              |
| 22             | 16            | 0x00        |  |
| 23             | 17            | 0x01        | EQ CHB2 = 0x01   |
| 24             | 18            | 0xAD        | VOD CHB2 = 101'b   |
| 25             | 19            | 0x00        | VOD_DB CHB2 = 000'b  |
| 26             | 1A            | 0x00        |  |
| 27             | 1B            | 0x1A        | EQ CHB3 = 0x01   |
| 28             | 1C            | 0xD0        | VOD CHB3 = 101'b, VOD_DB CHB3 = 000'b                              |
| 29             | 1D            | 0x09        | Signal Detect Status Threshold Control                             |
| 30             | 1E            | 0x80        | Signal Detect Status Threshold Control                             |
| 31             | 1F            | 0x07        | EQ CHA0 = 0x03   |
| 32             | 20            | 0x5C        | VOD CHA0 = 110'b   |
| 33             | 21            | 0x00        | VOD_DB CHA0 = 000'b  |
| 34             | 22            | 0x00        |  |
| 35             | 23            | 0x15        | EQ CHA1 = 0x00   |
| 36             | 24            | 0xC0        | VOD CHA1 = 110'b, VOD_DB CHA1 = 000'b                              |
| 37             | 25            | 0x00        |  |
| 38             | 26            | 0x07        | EQ CHA2 = 0x03   |
| 39             | 27            | 0x5C        | VOD CHA2 = 110'b   |
| 40             | 28            | 0x00        | VOD_DB CHA2 = 000'b  |
| 41             | 29            | 0x00        |  |
| 42             | 2A            | 0x75        | EQ CHA3 = 0x00   |
| 43             | 2B            | 0xC0        | VOD CHA3 = 110'b, VOD_DB CHA3 = 000'b                              |
| 44             | 2C            | 0x00        |  |
| 45             | 2D            | 0x00        |  |
| 46             | 2E            | 0x54        |  |

**Table 7. Example Of EEPROM for Four Devices Using Two Address Maps (continued)**

| EEPROM ADDRESS | ADDRESS (Hex) | EEPROM DATA | COMMENTS                               |
|----------------|---------------|-------------|--|
| 47             | 2F            | 0x54        | End Device 0, 1 - Address Offset 39    |
| 48             | 30            | 0x00        | Begin Device 2, 3 - Address Offset 3   |
| 49             | 31            | 0x00        |  |
| 50             | 32            | 0x04        |  |
| 51             | 33            | 0x07        |  |
| 52             | 34            | 0x00        |  |
| 53             | 35            | 0x01        | EQ CHB0 = 0x01                         |
| 54             | 36            | 0xAB        | VOD CHB0 = 011'b                       |
| 55             | 37            | 0x00        | VOD_DB CHB0 = 000'b                    |
| 56             | 38            | 0x00        |  |
| 57             | 39            | 0x1A        | EQ CHB1 = 0x01                         |
| 58             | 3A            | 0xB0        | VOD CHB1 = 011'b, VOD_DB CHB1 = 000'b  |
| 59             | 3B            | 0x00        |  |
| 60             | 3C            | 0x01        | EQ CHB2 = 0x01                         |
| 61             | 3D            | 0xAB        | VOD CHB2 = 011'b                       |
| 62             | 3E            | 0x00        | VOD_DB CHB2 = 000'b                    |
| 63             | 3F            | 0x00        |  |
| 64             | 40            | 0x1A        | EQ CHB3 = 0x01                         |
| 65             | 41            | 0xB0        | VOD CHB3 = 011'b, VOD_DB CHB3 = 000'b  |
| 66             | 42            | 0x09        | Signal Detect Status Threshold Control |
| 67             | 43            | 0x80        | Signal Detect Status Threshold Control |
| 68             | 44            | 0x07        | EQ CHA0 = 0x03                         |
| 69             | 45            | 0x5C        | VOD CHA0 = 110'b                       |
| 70             | 46            | 0x00        | VOD_DB CHA0 = 000'b                    |
| 71             | 47            | 0x00        |  |
| 72             | 48            | 0x15        | EQ CHA1 = 0x00                         |
| 73             | 49            | 0xA0        | VOD CHA1 = 101'b, VOD_DB CHA1 = 000'b  |
| 74             | 4A            | 0x00        |  |
| 75             | 4B            | 0x07        | EQ CHA2 = 0x03                         |
| 76             | 4C            | 0x5C        | VOD CHA2 = 110'b                       |
| 77             | 4D            | 0x00        | VOD_DB CHA2 = 000'b                    |
| 78             | 4E            | 0x00        |  |
| 79             | 4F            | 0x15        | EQ CHA3 = 0x00                         |
| 80             | 50            | 0xA0        | VOD CHA3 = 101'b, VOD_DB CHA3 = 000'b  |
| 81             | 51            | 0x00        |  |
| 82             | 52            | 0x00        |  |
| 83             | 53            | 0x54        |  |
| 84             | 54            | 0x54        | End Device 2, 3 - Address Offset 39    |

Note: CRC\_EN = 0, Address Map = 1, >256 byte = 0, Device Count[3:0] = 3. Multiple devices can point to the same address map. Maximum EEPROM size is 8 kbits (1024 x 8-bits).

## 7.7 Register Maps

The System Management Bus interface is compatible to SMBus 2.0 physical layer specification. Tie ENSMB = 1 k $\Omega$  to VDD (2.5 V mode) or VIN (3.3 V mode) to enable SMBus Slave Mode and allow access to the configuration registers.

The DS125BR820 uses AD[3:0] inputs in both SMBus Modes. These AD[3:0] pins are the user set SMBus slave address inputs and have internal pull-downs. Based on the SMBus 2.0 specification, the DS125BR820 has a 7-bit slave address. The LSB is set to 0'b (for a WRITE). When AD[3:0] pins are left floating or pulled low, AD[3:0] = 0000'b, and the device default address byte is 0xB0. The device supports up to 16 address bytes, as shown in [Table 8](#):

**Table 8. Device Slave Address Bytes**

| AD[3:0] SETTINGS | FULL SLAVE ADDRESS BYTE<br>(7-Bit ADDRESS + WRITE BIT) | 7-Bit SLAVE<br>ADDRESS (HEX) |
|------------------|--|------------------------------|
| 0000             | B0   | 58                           |
| 0001             | B2   | 59                           |
| 0010             | B4   | 5A                           |
| 0011             | B6   | 5B                           |
| 0100             | B8   | 5C                           |
| 0101             | BA   | 5D                           |
| 0110             | BC   | 5E                           |
| 0111             | BE   | 5F                           |
| 1000             | C0   | 60                           |
| 1001             | C2   | 61                           |
| 1010             | C4   | 62                           |
| 1011             | C6   | 63                           |
| 1100             | C8   | 64                           |
| 1101             | CA   | 65                           |
| 1110             | CC   | 66                           |
| 1111             | CE   | 67                           |

The SDA/SCL pins are 3.3 V tolerant, but are not 5V tolerant. An external pull-up resistor is required on the SDA line. The resistor value can be from 2 k $\Omega$  to 5 k $\Omega$  depending on the voltage, loading and speed. The SCL may also require an external pull-up resistor and it depends on the Host that drives the bus.

### 7.7.1 Transfer Of Data Via The SMBus

During normal operation, the data on SDA must be stable during the time when SCL is High.

There are three unique states for the SMBus:

**START:** A High-to-Low transition on SDA while SCL is High indicates a message START condition.

**STOP:** A Low-to-High transition on SDA while SCL is High indicates a message STOP condition.

**IDLE:** If SCL and SDA are both High for a time exceeding  $t_{BUF}$  from the last detected STOP condition or if they are High for a total exceeding the maximum specification for  $t_{HIGH}$ , then the bus transfers to the IDLE state.

### 7.7.2 SMBus Transactions

The device supports WRITE and READ transactions. See [Table 9](#) for register address, type (Read/Write, Read Only), default value, and function information.

### 7.7.3 Writing a Register

To write a register, the following protocol is used (see SMBus 2.0 specification).

1. The Host drives a START condition, the 7-bit SMBus address, and a “0” indicating a WRITE.
2. The Device (Slave) drives the ACK bit (“0”).
3. The Host drives the 8-bit Register Address.
4. The Device drives an ACK bit (“0”).
5. The Host drive the 8-bit data byte.
6. The Device drives an ACK bit (“0”).
7. The Host drives a STOP condition.

The WRITE transaction is completed, the bus goes IDLE, and communication with other SMBus devices may now occur.

### 7.7.4 Reading a Register

To read a register, the following protocol is used (see SMBus 2.0 specification).

1. The Host drives a START condition, the 7-bit SMBus address, and a “0” indicating a WRITE.
2. The Device (Slave) drives the ACK bit (“0”).
3. The Host drives the 8-bit Register Address.
4. The Device drives an ACK bit (“0”).
5. The Host drives a START condition.
6. The Host drives the 7-bit SMBus Address, and a “1” indicating a READ.
7. The Device drives an ACK bit “0”.
8. The Device drives the 8-bit data value (register contents).
9. The Host drives a NACK bit “1” indicating end of the READ transfer.
10. The Host drives a STOP condition.

The READ transaction is completed, the bus goes IDLE, and communication with other SMBus devices may now occur.

**7.7.5 Detailed Register Map**
**Table 9. SMBus Slave Mode Register Map**

| Address | Register Name             | Bit | Field                           | Type | Default | EEPROM Reg Bit | Description  |   |
|---------|---------------------------|-----|---------------------------------|------|---------|----------------|--|---|
| 0x00    | Observation               | 7   | Reserved                        | R/W  | 0x00    |                | Set bit to 0   |   |
|         |                           | 6:3 | Address Bit AD[3:0]             | R    |         |                | Observation of AD[3:0] bits<br>[6]: AD3<br>[5]: AD2<br>[4]: AD1<br>[3]: AD0  |   |
|         |                           | 2   | EEPROM Read Done                | R    |         |                | 1 = Device completed the read from external EEPROM   |   |
|         |                           | 1   | Reserved                        | R/W  |         |                | Set bit to 0   |   |
|         |                           | 0   | Reserved                        | R/W  |         |                | Set bit to 0   |   |
| 0x01    | PWDN Channels             | 7:0 | PWDN CHx                        | R/W  | 0x00    | Yes            | Power Down per Channel<br>[7]: CH7 – CHA_3<br>[6]: CH6 – CHA_2<br>[5]: CH5 – CHA_1<br>[4]: CH4 – CHA_0<br>[3]: CH3 – CHB_3<br>[2]: CH2 – CHB_2<br>[1]: CH1 – CHB_1<br>[0]: CH0 – CHB_0<br>0x00 = all channels enabled<br>0xFF = all channels disabled<br>Note: Override PWDN pin and enable register control via Reg 0x02[0] |   |
| 0x02    | Override PWDN, PRSNT      | 7   | Override PRSNT                  | R/W  | 0x00    |                | 1 = Override Automatic Rx Detect State Machine Reset   |   |
|         |                           | 6   | $\overline{\text{PRSNT}}$ Value |      |         |                | 1 = Set Rx Detect State Machine Reset<br>0 = Clear Rx Detect State Machine Reset   |   |
|         |                           | 5:2 | Reserved                        |      |         |                | Yes  | Set bits to 0   |
|         |                           | 1   | Reserved                        |      |         |                |  | Set bit to 0  |
|         |                           | 0   | Override PWDN                   |      |         |                | Yes  | 1 = Block PWDN pin control (Register control enabled)<br>0 = Allow PWDN pin control (Register control disabled)   |
| 0x03    | Reserved                  | 7:0 | Reserved                        | R/W  | 0x00    |                | Set bits to 0  |   |
| 0x04    | Reserved                  | 7:0 | Reserved                        | R/W  | 0x00    | Yes            | Set bits to 0  |   |
| 0x05    | Reserved                  | 7:0 | Reserved                        | R/W  | 0x00    |                | Set bits to 0  |   |
| 0x06    | Slave Register Control    | 7:5 | Reserved                        | R/W  | 0x10    |                | Set bits to 0  |   |
|         |                           | 4   | Reserved                        |      |         |                | Yes  | Set bit to 1  |
|         |                           | 3   | Register Enable                 |      |         |                |  | 1 = Enable SMBus Slave Mode Register Control<br><b>Note: In order to change VOD, VOD_DB, and EQ of the channels in slave mode, this bit must be set to 1.</b> |
|         |                           | 2:0 | Reserved                        |      |         |                |  | Set bits to 0   |
| 0x07    | Digital Reset and Control | 7   | Reserved                        | R/W  | 0x01    |                | Set bit to 0   |   |
|         |                           | 6   | Reset Registers                 |      |         |                | 1 = Self clearing reset for SMBus registers (register settings return to default values)   |   |
|         |                           | 5   | Reset SMBus Master              |      |         |                | 1 = Self clearing reset to SMBus master state machine  |   |
|         |                           | 4:0 | Reserved                        |      |         |                | Set bits to 0 0001'b   |   |
| 0x08    | Override Pin Control      | 7   | Reserved                        | R/W  | 0x00    |                | Set bit to 0   |   |
|         |                           | 6   | Override SD_TH                  |      |         |                | Yes  | 1 = Block SD_TH pin control (Register control enabled)<br>0 = Allow SD_TH pin control (Register control disabled)   |
|         |                           | 5:4 | Reserved                        |      |         |                | Yes  | Set bits to 0   |
|         |                           | 3   | Override RXDET                  |      |         |                | Yes  | 1 = Block RXDET pin control (Register control enabled)<br>0 = Allow RXDET pin control (Register control disabled)   |
|         |                           | 2:0 | Reserved                        |      |         |                | Yes  | Set bits to 0   |

**Table 9. SMBus Slave Mode Register Map (continued)**

| Address   | Register Name         | Bit | Field                    | Type | Default | EEPROM Reg Bit | Description  |
|-----------|-----------------------|-----|--------------------------|------|---------|----------------|--|
| 0x09      | Reserved              | 7:0 | Reserved                 | R/W  | 0x00    |                | Set bits to 0  |
| 0x0A      | Signal Detect Monitor | 7:0 | SD_TH Status             | R    | 0x00    |                | CH7 - CH0 Internal Signal Detect Indicator<br>[7]: CH7 – CHA_3<br>[6]: CH6 – CHA_2<br>[5]: CH5 – CHA_1<br>[4]: CH4 – CHA_0<br>[3]: CH3 – CHB_3<br>[2]: CH2 – CHB_2<br>[1]: CH1 – CHB_1<br>[0]: CH0 – CHB_0<br>0 = Signal detected at input<br>1 = Signal not detected at input<br>Note: These bits only function when RESERVED2 pin = FLOAT  |
| 0x0B      | Reserved              | 7   | Reserved                 | R/W  | 0x00    |                | Set bit to 0   |
|           |                       | 6:0 | Reserved                 | R/W  | 0x70    | Yes            | Set bits to 111 0000'b   |
| 0x0C-0x0D | Reserved              | 7:0 | Reserved                 | R/W  | 0x00    |                | Set bits to 0  |
| 0x0E      | CH0 - CHB_0<br>RXDET  | 7:6 | Reserved                 | R/W  | 0x00    |                | Set bits to 0  |
|           |                       | 5:4 | Reserved                 |      |         | Yes            | Set bits to 0  |
|           |                       | 3:2 | RXDET                    |      |         | Yes            | 00'b = Input is Hi-Z impedance<br>01'b = Auto Rx-Detect,<br>outputs test every 12 ms for 600 ms (50 times) then stops; termination is Hi-Z until detection; once detected input termination is 50 Ω<br>10'b = Auto Rx-Detect,<br>outputs test every 12 ms until detection occurs; termination is Hi-Z until detection; once detected input termination is 50 Ω<br>11'b = Input is 50 Ω<br>Note: Override RXDET pin and enable register control via Reg 0x08[3] |
|           |                       | 1:0 | Reserved                 |      |         |                | Set bits to 0  |
| 0x0F      | CH0 - CHB_0<br>EQ     | 7:0 | EQ Control               | R/W  | 0x2F    | Yes            | INB_0 EQ Control - total of four levels.<br>See <a href="#">Table 4</a> .  |
| 0x10      | CH0 - CHB_0<br>VOD    | 7   | Short Circuit Protection | R/W  | 0xAD    | Yes            | 1 = Enable the short circuit protection<br>0 = Disable the short circuit protection  |
|           |                       | 6:3 | Reserved                 |      |         | Yes            | Set bits to 0101'b   |
|           |                       | 2:0 | VOD Control              |      |         | Yes            | OUTB_0 VOD Control: VOD / VID Ratio<br>000'b = 0.57<br>001'b = 0.65<br>010'b = 0.71<br>011'b = 0.77<br>100'b = 0.83<br>101'b = 0.90 (default)<br>110'b = 1.00 (recommended)<br>111'b = 1.04  |

**Table 9. SMBus Slave Mode Register Map (continued)**

| Address   | Register Name         | Bit | Field                                    | Type | Default | EEPROM Reg Bit | Description  |
|-----------|-----------------------|-----|--|------|---------|----------------|--|
| 0x11      | CH0 - CHB_0<br>VOD_DB | 7   | RXDET Status                             | R    | 0x02    |                | Observation bit for RXDET CH0 - CHB_0<br>1 = Input 50 Ω terminated to VDD<br>0 = Input is Hi-Z   |
|           |                       | 6:5 | Reserved                                 |      |         |                | Set bits to 0  |
|           |                       | 4:3 | Reserved                                 |      |         |                | Set bits to 0  |
|           |                       | 2:0 | VOD_DB Control                           | R/W  |         | Yes            | OUTB_0 VOD_DB Control<br>000'b = 0 dB (recommended)<br>001'b = -1.5 dB<br>010'b = -3.5 dB (default)<br>011'b = -5 dB<br>100'b = -6 dB<br>101'b = -8 dB<br>110'b = -9 dB<br>111'b = -12 dB<br>Note: Changing VOD_DB bits effectively lowers the output VOD dynamic range by a factor of the corresponding amount of dB reduction.   |
| 0x12      | CH0 - CHB_0<br>SD_TH  | 7   | Reserved                                 | R/W  | 0x00    | Yes            | Set bit to 0   |
|           |                       | 6:4 | Reserved                                 |      |         |                | Set bits to 0  |
|           |                       | 3:2 | Signal Detect Status Assert Threshold    |      |         | Yes            | Status Assert threshold (1010 pattern 12 Gbps)<br>00'b = 50 mVp-p (default)<br>01'b = 40 mVp-p<br>10'b = 75 mVp-p<br>11'b = 58 mVp-p<br>Note: Override SD_TH pin and enable register control via Reg 0x08[6]   |
|           |                       | 1:0 | Signal Detect Status De-assert Threshold |      |         | Yes            | Status De-assert threshold (1010 pattern 12 Gbps)<br>00'b = 37 mVp-p (default)<br>01'b = 22 mVp-p<br>10'b = 55 mVp-p<br>11'b = 45 mVp-p<br>Note: Override SD_TH pin and enable register control via Reg 0x08[6]  |
| 0x13-0x14 | Reserved              | 7:0 | Reserved                                 | R/W  | 0x00    |                | Set bits to 0  |
| 0x15      | CH1 - CHB_1<br>RXDET  | 7:6 | Reserved                                 | R/W  | 0x00    |                | Set bits to 0  |
|           |                       | 5:4 | Reserved                                 |      |         | Yes            | Set bits to 0  |
|           |                       | 3:2 | RXDET                                    |      |         | Yes            | 00'b = Input is Hi-Z impedance<br>01'b = Auto Rx-Detect, outputs test every 12 ms for 600 ms (50 times) then stops; termination is Hi-Z until detection; once detected input termination is 50 Ω<br>10'b = Auto Rx-Detect, outputs test every 12 ms until detection occurs; termination is Hi-Z until detection; once detected input termination is 50 Ω<br>11'b = Input is 50 Ω<br>Note: Override RXDET pin and enable register control via Reg 0x08[3] |
|           |                       | 1:0 | Reserved                                 |      |         |                | Set bits to 0  |
| 0x16      | CH1 - CHB_1 EQ        | 7:0 | EQ Control                               | R/W  | 0x2F    | Yes            | INB_1 EQ Control - total of four levels. See <a href="#">Table 4</a> .   |

**Table 9. SMBus Slave Mode Register Map (continued)**

| Address   | Register Name         | Bit | Field                                    | Type | Default | EEPROM Reg Bit | Description  |
|-----------|-----------------------|-----|--|------|---------|----------------|--|
| 0x17      | CH1 - CHB_1<br>VOD    | 7   | Short Circuit Protection                 | R/W  | 0xAD    | Yes            | 1 = Enable the short circuit protection<br>0 = Disable the short circuit protection  |
|           |                       | 6:3 | Reserved                                 |      |         | Yes            | Set bits to 0101'b   |
|           |                       | 2:0 | VOD Control                              |      |         | Yes            | OUTB_1 VOD Control: VOD / VID Ratio<br>000'b = 0.57<br>001'b = 0.65<br>010'b = 0.71<br>011'b = 0.77<br>100'b = 0.83<br>101'b = 0.90 (default)<br>110'b = 1.00 (recommended)<br>111'b = 1.04  |
| 0x18      | CH1 - CHB_1<br>VOD_DB | 7   | RXDET Status                             | R    | 0x02    |                | Observation bit for RXDET CH1 - CHB_1<br>1 = Input 50 Ω terminated to VDD<br>0 = Input is Hi-Z   |
|           |                       | 6:5 | Reserved                                 |      |         | Set bits to 0  |  |
|           |                       | 4:3 | Reserved                                 |      |         | Set bits to 0  |  |
|           |                       | 2:0 | VOD_DB Control                           | R/W  |         | Yes            | OUTB_1 VOD_DB Control<br>000'b = 0 dB (recommended)<br>001'b = -1.5 dB<br>010'b = -3.5 dB (default)<br>011'b = -5 dB<br>100'b = -6 dB<br>101'b = -8 dB<br>110'b = -9 dB<br>111'b = -12 dB<br>Note: Changing VOD_DB bits effectively lowers the output VOD dynamic range by a factor of the corresponding amount of dB reduction. |
| 0x19      | CH1 - CHB_1<br>SD_TH  | 7   | Reserved                                 | R/W  | 0x00    | Yes            | Set bit to 0   |
|           |                       | 6:4 | Reserved                                 |      |         |                | Set bits to 0  |
|           |                       | 3:2 | Signal Detect Status Assert Threshold    |      |         | Yes            | Status Assert threshold (1010 pattern 12 Gbps)<br>00'b = 50 mVp-p (default)<br>01'b = 40 mVp-p<br>10'b = 75 mVp-p<br>11'b = 58 mVp-p<br>Note: Override SD_TH pin and enable register control via Reg 0x08[6]   |
|           |                       | 1:0 | Signal Detect Status De-assert Threshold |      |         | Yes            | Status De-assert threshold (1010 pattern 12 Gbps)<br>00'b = 37 mVp-p (default)<br>01'b = 22 mVp-p<br>10'b = 55 mVp-p<br>11'b = 45 mVp-p<br>Note: Override SD_TH pin and enable register control via Reg 0x08[6]  |
| 0x1A-0x1B | Reserved              | 7:0 | Reserved                                 | R/W  | 0x00    |                | Set bits to 0  |

**Table 9. SMBus Slave Mode Register Map (continued)**

| Address | Register Name         | Bit | Field                    | Type | Default | EEPROM Reg Bit | Description  |
|---------|-----------------------|-----|--------------------------|------|---------|----------------|--|
| 0x1C    | CH2 - CHB_2<br>RXDET  | 7:6 | Reserved                 | R/W  | 0x00    |                | Set bits to 0  |
|         |                       | 5:4 | Reserved                 |      |         | Yes            | Set bits to 0  |
|         |                       | 3:2 | RXDET                    |      |         | Yes            | 00'b = Input is Hi-Z impedance<br>01'b = Auto Rx-Detect, outputs test every 12 ms for 600 ms (50 times) then stops; termination is Hi-Z until detection; once detected input termination is 50 Ω<br>10'b = Auto Rx-Detect, outputs test every 12 ms until detection occurs; termination is Hi-Z until detection; once detected input termination is 50 Ω<br>11'b = Input is 50 Ω<br>Note: Override RXDET pin and enable register control via Reg 0x08[3] |
|         |                       | 1:0 | Reserved                 |      |         |                | Set bits to 0  |
| 0x1D    | CH2 - CHB_2<br>EQ     | 7:0 | EQ Control               | R/W  | 0x2F    | Yes            | INB_2 EQ Control - total of four levels. See Table 4.  |
| 0x1E    | CH2 - CHB_2<br>VOD    | 7   | Short Circuit Protection | R/W  | 0xAD    | Yes            | 1 = Enable the short circuit protection<br>0 = Disable the short circuit protection  |
|         |                       | 6:3 | Reserved                 |      |         | Yes            | Set bits to 0101'b   |
|         |                       | 2:0 | VOD Control              |      |         | Yes            | OUTB_2 VOD Control: VOD / VID Ratio<br>000'b = 0.57<br>001'b = 0.65<br>010'b = 0.71<br>011'b = 0.77<br>100'b = 0.83<br>101'b = 0.90 (default)<br>110'b = 1.00 (recommended)<br>111'b = 1.04  |
| 0x1F    | CH2 - CHB_2<br>VOD_DB | 7   | RXDET Status             | R    | 0x02    |                | Observation bit for RXDET CH2 - CHB_2<br>1 = Input 50 Ω terminated to VDD<br>0 = Input is Hi-Z   |
|         |                       | 6:5 | Reserved                 |      |         | Set bits to 0  |  |
|         |                       | 4:3 | Reserved                 |      |         | Set bits to 0  |  |
|         |                       | 2:0 | VOD_DB Control           | R/W  |         | Yes            | OUTB_2 VOD_DB Control<br>000'b = 0 dB (recommended)<br>001'b = -1.5 dB<br>010'b = -3.5 dB (default)<br>011'b = -5 dB<br>100'b = -6 dB<br>101'b = -8 dB<br>110'b = -9 dB<br>111'b = -12 dB<br>Note: Changing VOD_DB bits effectively lowers the output VOD dynamic range by a factor of the corresponding amount of dB reduction.   |

**Table 9. SMBus Slave Mode Register Map (continued)**

| Address       | Register Name        | Bit | Field   | Type | Default | EEPROM Reg Bit | Description   |
|---------------|----------------------|-----|---|------|---------|----------------|---|
| 0x20          | CH2 - CHB_2<br>SD_TH | 7   | Reserved  | R/W  | 0x00    | Yes            | Set bit to 0  |
|               |                      | 6:4 | Reserved  |      |         |                | Set bits to 0   |
|               |                      | 3:2 | Signal Detect<br>Status Assert<br>Threshold       |      |         | Yes            | Status Assert threshold (1010 pattern 12 Gbps)<br>00'b = 50 mVp-p (default)<br>01'b = 40 mVp-p<br>10'b = 75 mVp-p<br>11'b = 58 mVp-p<br>Note: Override SD_TH pin and enable register control<br>via Reg 0x08[6]   |
|               |                      | 1:0 | Signal Detect<br>Status<br>De-assert<br>Threshold |      |         | Yes            | Status De-assert threshold (1010 pattern 12 Gbps)<br>00'b = 37 mVp-p (default)<br>01'b = 22 mVp-p<br>10'b = 55 mVp-p<br>11'b = 45 mVp-p<br>Note: Override SD_TH pin and enable register control<br>via Reg 0x08[6]  |
| 0x21-<br>0x22 | Reserved             | 7:0 | Reserved  | R/W  | 0x00    |                | Set bits to 0   |
| 0x23          | CH3 - CHB_3<br>RXDET | 7:6 | Reserved  | R/W  | 0x00    |                | Set bits to 0   |
|               |                      | 5:4 | Reserved  |      |         | Yes            | Set bits to 0   |
|               |                      | 3:2 | RXDET   |      |         | Yes            | 00'b = Input is Hi-Z impedance<br>01'b = Auto Rx-Detect,<br>outputs test every 12 ms for 600 ms (50 times) then<br>stops; termination is Hi-Z until detection; once detected<br>input termination is 50 Ω<br>10'b = Auto Rx-Detect,<br>outputs test every 12 ms until detection occurs;<br>termination is Hi-Z until detection; once detected input<br>termination is 50 Ω<br>11'b = Input is 50 Ω<br>Note: Override RXDET pin and enable register control<br>via Reg 0x08[3] |
|               |                      | 1:0 | Reserved  |      |         |                | Set bits to 0   |
| 0x24          | CH3 - CHB_3<br>EQ    | 7:0 | EQ Control  | R/W  | 0x2F    | Yes            | INB_3 EQ Control - total of four levels.<br>See <a href="#">Table 4</a> .   |
| 0x25          | CH3 - CHB_3<br>VOD   | 7   | Short Circuit<br>Protection                       | R/W  | 0xAD    | Yes            | 1 = Enable the short circuit protection<br>0 = Disable the short circuit protection   |
|               |                      | 6:3 | Reserved  |      |         | Yes            | Set bits to 0101'b  |
|               |                      | 2:0 | VOD Control                                       |      |         | Yes            | OUTB_3 VOD Control: VOD / VID Ratio<br>000'b = 0.57<br>001'b = 0.65<br>010'b = 0.71<br>011'b = 0.77<br>100'b = 0.83<br>101'b = 0.90 (default)<br>110'b = 1.00 (recommended)<br>111'b = 1.04   |

**Table 9. SMBus Slave Mode Register Map (continued)**

| Address   | Register Name                | Bit | Field                                    | Type | Default | EEPROM Reg Bit | Description  |
|-----------|------------------------------|-----|--|------|---------|----------------|--|
| 0x26      | CH3 - CHB_3<br>VOD_DB        | 7   | RXDET Status                             | R    | 0x02    |                | Observation bit for RXDET CH3 - CHB_3<br>1 = Input 50 Ω terminated to VDD<br>0 = Input is Hi-Z   |
|           |                              | 6:5 | Reserved                                 |      |         | Set bits to 0  |  |
|           |                              | 4:3 | Reserved                                 |      |         | Set bits to 0  |  |
|           |                              | 2:0 | VOD_DB Control                           | R/W  |         | Yes            | OUTB_3 VOD_DB Control<br>000'b = 0 dB (recommended)<br>001'b = -1.5 dB<br>010'b = -3.5 dB (default)<br>011'b = -5 dB<br>100'b = -6 dB<br>101'b = -8 dB<br>110'b = -9 dB<br>111'b = -12 dB<br>Note: Changing VOD_DB bits effectively lowers the output VOD dynamic range by a factor of the corresponding amount of dB reduction. |
| 0x27      | CH3 - CHB_3<br>SD_TH         | 7   | Reserved                                 | R/W  | 0x00    | Yes            | Set bit to 0   |
|           |                              | 6:4 | Reserved                                 |      |         |                | Set bits to 0  |
|           |                              | 3:2 | Signal Detect Status Assert Threshold    |      |         | Yes            | Status Assert threshold (1010 pattern 12 Gbps)<br>00'b = 50 mVp-p (default)<br>01'b = 40 mVp-p<br>10'b = 75 mVp-p<br>11'b = 58 mVp-p<br>Note: Override SD_TH pin and enable register control via Reg 0x08[6]   |
|           |                              | 1:0 | Signal Detect Status De-assert Threshold |      |         | Yes            | Status De-assert threshold (1010 pattern 12 Gbps)<br>00'b = 37 mVp-p (default)<br>01'b = 22 mVp-p<br>10'b = 55 mVp-p<br>11'b = 45 mVp-p<br>Note: Override SD_TH pin and enable register control via Reg 0x08[6]  |
| 0x28      | Signal Detect Status Control | 7   | Reserved                                 | R/W  | 0x4C    |                | Set bit to 0   |
|           |                              | 6   | Reserved                                 |      |         | Yes            | Set bit to 1   |
|           |                              | 5:4 | High SD_TH Status                        |      |         | Yes            | Enable Higher Range of Signal Detect Status Thresholds<br>[5]: CH0 - CH3<br>[4]: CH4 - CH7   |
|           |                              | 3:2 | Fast Signal Detect Status                |      |         | Yes            | Enable Fast Signal Detect Status<br>[3]: CH0 - CH3<br>[2]: CH4 - CH7<br>Note: In Fast Signal Detect, assert/de-assert response occurs after approximately 3-4 ns   |
|           |                              | 1:0 | Reduced SD Status Gain                   |      |         | Yes            | Enable Reduced Signal Detect Status Gain<br>[1]: CH0 - CH3<br>[0]: CH4 - CH7   |
| 0x29-0x2A | Reserved                     | 7:0 | Reserved                                 | R/W  | 0x00    |                | Set bits to 0  |

**Table 9. SMBus Slave Mode Register Map (continued)**

| Address | Register Name         | Bit | Field                    | Type | Default | EEPROM Reg Bit | Description  |
|---------|-----------------------|-----|--------------------------|------|---------|----------------|--|
| 0x2B    | CH4 - CHA_0<br>RXDET  | 7:6 | Reserved                 | R/W  | 0x00    |                | Set bits to 0  |
|         |                       | 5:4 | Reserved                 |      |         | Yes            | Set bits to 0  |
|         |                       | 3:2 | RXDET                    |      |         | Yes            | 00'b = Input is Hi-Z impedance<br>01'b = Auto Rx-Detect, outputs test every 12 ms for 600 ms (50 times) then stops; termination is Hi-Z until detection; once detected input termination is 50 Ω<br>10'b = Auto Rx-Detect, outputs test every 12 ms until detection occurs; termination is Hi-Z until detection; once detected input termination is 50 Ω<br>11'b = Input is 50 Ω<br>Note: Override RXDET pin and enable register control via Reg 0x08[3] |
|         |                       | 1:0 | Reserved                 |      |         |                | Set bits to 0  |
| 0x2C    | CH4 - CHA_0<br>EQ     | 7:0 | EQ Control               | R/W  | 0x2F    | Yes            | INA_0 EQ Control - total of four levels. See Table 4.  |
| 0x2D    | CH4 - CHA_0<br>VOD    | 7   | Short Circuit Protection | R/W  | 0xAD    | Yes            | 1 = Enable the short circuit protection<br>0 = Disable the short circuit protection  |
|         |                       | 6:3 | Reserved                 |      |         | Yes            | Set bits to 0101'b   |
|         |                       | 2:0 | VOD Control              |      |         | Yes            | OUTA_0 VOD Control: VOD / VID Ratio<br>000'b = 0.57<br>001'b = 0.65<br>010'b = 0.71<br>011'b = 0.77<br>100'b = 0.83<br>101'b = 0.90 (default)<br>110'b = 1.00 (recommended)<br>111'b = 1.04  |
| 0x2E    | CH4 - CHA_0<br>VOD_DB | 7   | RXDET Status             | R    | 0x02    |                | Observation bit for RXDET CH4 - CHA_0<br>1 = Input 50 Ω terminated to VDD<br>0 = Input is Hi-Z   |
|         |                       | 6:5 | Reserved                 |      |         | Set bits to 0  |  |
|         |                       | 4:3 | Reserved                 |      |         | Set bits to 0  |  |
|         |                       | 2:0 | VOD_DB Control           | R/W  |         | Yes            | OUTA_0 VOD_DB Control<br>000'b = 0 dB (recommended)<br>001'b = -1.5 dB<br>010'b = -3.5 dB (default)<br>011'b = -5 dB<br>100'b = -6 dB<br>101'b = -8 dB<br>110'b = -9 dB<br>111'b = -12 dB<br>Note: Changing VOD_DB bits effectively lowers the output VOD dynamic range by a factor of the corresponding amount of dB reduction.   |

**Table 9. SMBus Slave Mode Register Map (continued)**

| Address       | Register Name        | Bit | Field   | Type | Default | EEPROM Reg Bit | Description   |
|---------------|----------------------|-----|---|------|---------|----------------|---|
| 0x2F          | CH4 - CHA_0<br>SD_TH | 7   | Reserved  | R/W  | 0x00    | Yes            | Set bit to 0  |
|               |                      | 6:4 | Reserved  |      |         |                | Set bits to 0   |
|               |                      | 3:2 | Signal Detect<br>Status Assert<br>Threshold       |      |         | Yes            | Status Assert threshold (1010 pattern 12 Gbps)<br>00'b = 50 mVp-p (default)<br>01'b = 40 mVp-p<br>10'b = 75 mVp-p<br>11'b = 58 mVp-p<br>Note: Override SD_TH pin and enable register control<br>via Reg 0x08[6]   |
|               |                      | 1:0 | Signal Detect<br>Status<br>De-assert<br>Threshold |      |         | Yes            | Status De-assert threshold (1010 pattern 12 Gbps)<br>00'b = 37 mVp-p (default)<br>01'b = 22 mVp-p<br>10'b = 55 mVp-p<br>11'b = 45 mVp-p<br>Note: Override SD_TH pin and enable register control<br>via Reg 0x08[6]  |
| 0x30-<br>0x31 | Reserved             | 7:0 | Reserved  | R/W  | 0x00    |                | Set bits to 0   |
| 0x32          | CH5 - CHA_1<br>RXDET | 7:6 | Reserved  | R/W  | 0x00    |                | Set bits to 0   |
|               |                      | 5:4 | Reserved  |      |         | Yes            | Set bits to 0   |
|               |                      | 3:2 | RXDET   |      |         | Yes            | 00'b = Input is Hi-Z impedance<br>01'b = Auto Rx-Detect,<br>outputs test every 12 ms for 600 ms (50 times) then<br>stops; termination is Hi-Z until detection; once detected<br>input termination is 50 Ω<br>10'b = Auto Rx-Detect,<br>outputs test every 12 ms until detection occurs;<br>termination is Hi-Z until detection; once detected input<br>termination is 50 Ω<br>11'b = Input is 50 Ω<br>Note: Override RXDET pin and enable register control<br>via Reg 0x08[3] |
|               |                      | 1:0 | Reserved  |      |         |                | Set bits to 0   |
| 0x33          | CH5 - CHA_1<br>EQ    | 7:0 | EQ Control  | R/W  | 0x2F    | Yes            | INA_1 EQ Control - total of four levels.<br>See <a href="#">Table 4</a> .   |
| 0x34          | CH5 - CHA_1<br>VOD   | 7   | Short Circuit<br>Protection                       | R/W  | 0xAD    | Yes            | 1 = Enable the short circuit protection<br>0 = Disable the short circuit protection   |
|               |                      | 6:3 | Reserved  |      |         | Yes            | Set bits to 0101'b  |
|               |                      | 2:0 | VOD Control                                       |      |         | Yes            | OUTA_1 VOD Control: VOD / VID Ratio<br>000'b = 0.57<br>001'b = 0.65<br>010'b = 0.71<br>011'b = 0.77<br>100'b = 0.83<br>101'b = 0.90 (default)<br>110'b = 1.00 (recommended)<br>111'b = 1.04   |

**Table 9. SMBus Slave Mode Register Map (continued)**

| Address   | Register Name         | Bit | Field                                    | Type | Default | EEPROM Reg Bit | Description  |
|-----------|-----------------------|-----|--|------|---------|----------------|--|
| 0x35      | CH5 - CHA_1<br>VOD_DB | 7   | RXDET Status                             | R    | 0x02    |                | Observation bit for RXDET CH5 - CHA1<br>1 = Input 50 Ω terminated to VDD<br>0 = Input is Hi-Z  |
|           |                       | 6:5 | Reserved                                 |      |         | Set bits to 0  |  |
|           |                       | 4:3 | Reserved                                 |      |         | Set bits to 0  |  |
|           |                       | 2:0 | VOD_DB Control                           | R/W  |         | Yes            | OUTA_1 VOD_DB Control<br>000'b = 0 dB (recommended)<br>001'b = -1.5 dB<br>010'b = -3.5 dB (default)<br>011'b = -5 dB<br>100'b = -6 dB<br>101'b = -8 dB<br>110'b = -9 dB<br>111'b = -12 dB<br>Note: Changing VOD_DB bits effectively lowers the output VOD dynamic range by a factor of the corresponding amount of dB reduction.   |
| 0x36      | CH5 - CHA_1<br>SD_TH  | 7   | Reserved                                 | R/W  | 0x00    | Yes            | Set bit to 0   |
|           |                       | 6:4 | Reserved                                 |      |         |                | Set bits to 0  |
|           |                       | 3:2 | Signal Detect Status Assert Threshold    |      |         | Yes            | Status Assert threshold (1010 pattern 12 Gbps)<br>00'b = 50 mVp-p (default)<br>01'b = 40 mVp-p<br>10'b = 75 mVp-p<br>11'b = 58 mVp-p<br>Note: Override SD_TH pin and enable register control via Reg 0x08[6]   |
|           |                       | 1:0 | Signal Detect Status De-assert Threshold |      |         | Yes            | Status De-assert threshold (1010 pattern 12 Gbps)<br>00'b = 37 mVp-p (default)<br>01'b = 22 mVp-p<br>10'b = 55 mVp-p<br>11'b = 45 mVp-p<br>Note: Override SD_TH pin and enable register control via Reg 0x08[6]  |
| 0x37-0x38 | Reserved              | 7:0 | Reserved                                 | R/W  | 0x00    |                | Set bits to 0  |
| 0x39      | CH6 - CHA_2<br>RXDET  | 7:6 | Reserved                                 | R/W  | 0x00    |                | Set bits to 0  |
|           |                       | 5:4 | Reserved                                 |      |         | Yes            | Set bits to 0  |
|           |                       | 3:2 | RXDET                                    |      |         | Yes            | 00'b = Input is Hi-Z impedance<br>01'b = Auto Rx-Detect, outputs test every 12 ms for 600 ms (50 times) then stops; termination is Hi-Z until detection; once detected input termination is 50 Ω<br>10'b = Auto Rx-Detect, outputs test every 12 ms until detection occurs; termination is Hi-Z until detection; once detected input termination is 50 Ω<br>11'b = Input is 50 Ω<br>Note: Override RXDET pin and enable register control via Reg 0x08[3] |
|           |                       | 1:0 | Reserved                                 |      |         |                | Set bits to 0  |
| 0x3A      | CH6 - CHA_2<br>EQ     | 7:0 | EQ Control                               | R/W  | 0x2F    | Yes            | INA_2 EQ Control - total of four levels.<br>See <a href="#">Table 4</a> .  |

**Table 9. SMBus Slave Mode Register Map (continued)**

| Address   | Register Name      | Bit | Field                                    | Type | Default | EEPROM Reg Bit | Description  |
|-----------|--------------------|-----|--|------|---------|----------------|--|
| 0x3B      | CH6 - CHA_2 VOD    | 7   | Short Circuit Protection                 | R/W  | 0xAD    | Yes            | 1 = Enable the short circuit protection<br>0 = Disable the short circuit protection  |
|           |                    | 6:3 | Reserved                                 |      |         | Yes            | Set bits to 0101'b   |
|           |                    | 2:0 | VOD Control                              |      |         | Yes            | OUTA_2 VOD Control: VOD / VID Ratio<br>000'b = 0.57<br>001'b = 0.65<br>010'b = 0.71<br>011'b = 0.77<br>100'b = 0.83<br>101'b = 0.90 (default)<br>110'b = 1.00 (recommended)<br>111'b = 1.04  |
| 0x3C      | CH6 - CHA_2 VOD_DB | 7   | RXDET Status                             | R    | 0x02    |                | Observation bit for RXDET CH6 - CHA_2<br>1 = Input 50 Ω terminated to VDD<br>0 = Input is Hi-Z   |
|           |                    | 6:5 | Reserved                                 |      |         | Set bits to 0  |  |
|           |                    | 4:3 | Reserved                                 |      |         | Set bits to 0  |  |
|           |                    | 2:0 | VOD_DB Control                           | R/W  |         | Yes            | OUTA_2 VOD_DB Control<br>000'b = 0 dB (recommended)<br>001'b = -1.5 dB<br>010'b = -3.5 dB (default)<br>011'b = -5 dB<br>100'b = -6 dB<br>101'b = -8 dB<br>110'b = -9 dB<br>111'b = -12 dB<br>Note: Changing VOD_DB bits effectively lowers the output VOD dynamic range by a factor of the corresponding amount of dB reduction. |
| 0x3D      | CH6 - CHA_2 SD_TH  | 7   | Reserved                                 | R/W  | 0x00    | Yes            | Set bit to 0   |
|           |                    | 6:4 | Reserved                                 |      |         |                | Set bits to 0  |
|           |                    | 3:2 | Signal Detect Status Assert Threshold    |      |         | Yes            | Status Assert threshold (1010 pattern 12 Gbps)<br>00'b = 50 mVp-p (default)<br>01'b = 40 mVp-p<br>10'b = 75 mVp-p<br>11'b = 58 mVp-p<br>Note: Override SD_TH pin and enable register control via Reg 0x08[6]   |
|           |                    | 1:0 | Signal Detect Status De-assert Threshold |      |         | Yes            | Status De-assert threshold (1010 pattern 12 Gbps)<br>00'b = 37 mVp-p (default)<br>01'b = 22 mVp-p<br>10'b = 55 mVp-p<br>11'b = 45 mVp-p<br>Note: Override SD_TH pin and enable register control via Reg 0x08[6]  |
| 0x3E-0x3F | Reserved           | 7:0 | Reserved                                 | R/W  | 0x00    |                | Set bits to 0  |

**Table 9. SMBus Slave Mode Register Map (continued)**

| Address | Register Name         | Bit | Field                    | Type | Default | EEPROM Reg Bit | Description  |
|---------|-----------------------|-----|--------------------------|------|---------|----------------|--|
| 0x40    | CH7 - CHA_3<br>RXDET  | 7:6 | Reserved                 | R/W  | 0x00    |                | Set bits to 0  |
|         |                       | 5:4 | Reserved                 |      |         | Yes            | Set bits to 0  |
|         |                       | 3:2 | RXDET                    |      |         | Yes            | 00'b = Input is Hi-Z impedance<br>01'b = Auto Rx-Detect, outputs test every 12 ms for 600 ms (50 times) then stops; termination is Hi-Z until detection; once detected input termination is 50 Ω<br>10'b = Auto Rx-Detect, outputs test every 12 ms until detection occurs; termination is Hi-Z until detection; once detected input termination is 50 Ω<br>11'b = Input is 50 Ω<br>Note: Override RXDET pin and enable register control via Reg 0x08[3] |
|         |                       | 1:0 | Reserved                 |      |         |                | Set bits to 0  |
| 0x41    | CH7 - CHA_3<br>EQ     | 7:0 | EQ Control               | R/W  | 0x2F    | Yes            | INA_3 EQ Control - total of four levels. See Table 4.  |
| 0x42    | CH7 - CHA_3<br>VOD    | 7   | Short Circuit Protection | R/W  | 0xAD    | Yes            | 1 = Enable the short circuit protection<br>0 = Disable the short circuit protection  |
|         |                       | 6:3 | Reserved                 |      |         | Yes            | Set bits to 0101'b   |
|         |                       | 2:0 | VOD Control              |      |         | Yes            | OUTA_3 VOD Control: VOD / VID Ratio<br>000'b = 0.57<br>001'b = 0.65<br>010'b = 0.71<br>011'b = 0.77<br>100'b = 0.83<br>101'b = 0.90 (default)<br>110'b = 1.00 (recommended)<br>111'b = 1.04  |
| 0x43    | CH7 - CHA_3<br>VOD_DB | 7   | RXDET Status             | R    | 0x02    |                | Observation bit for RXDET CH7 - CHA_3<br>1 = Input 50 Ω terminated to VDD<br>0 = Input is Hi-Z   |
|         |                       | 6:5 | Reserved                 |      |         | Set bits to 0  |  |
|         |                       | 4:3 | Reserved                 |      |         | Set bits to 0  |  |
|         |                       | 2:0 | VOD_DB Control           | R/W  |         | Yes            | OUTA_3 VOD_DB Control<br>000'b = 0 dB (recommended)<br>001'b = -1.5 dB<br>010'b = -3.5 dB (default)<br>011'b = -5 dB<br>100'b = -6 dB<br>101'b = -8 dB<br>110'b = -9 dB<br>111'b = -12 dB<br>Note: Changing VOD_DB bits effectively lowers the output VOD dynamic range by a factor of the corresponding amount of dB reduction.   |

**Table 9. SMBus Slave Mode Register Map (continued)**

| Address       | Register Name        | Bit | Field   | Type | Default | EEPROM Reg Bit | Description  |
|---------------|----------------------|-----|---|------|---------|----------------|--|
| 0x44          | CH7 - CHA_3<br>SD_TH | 7   | Reserved  | R/W  | 0x00    | Yes            | Set bit to 0   |
|               |                      | 6:4 | Reserved  |      |         |                | Set bits to 0  |
|               |                      | 3:2 | Signal Detect<br>Status Assert<br>Threshold       |      |         | Yes            | Status Assert threshold (1010 pattern 12 Gbps)<br>00'b = 50 mVp-p (default)<br>01'b = 40 mVp-p<br>10'b = 75 mVp-p<br>11'b = 58 mVp-p<br>Note: Override SD_TH pin and enable register control<br>via Reg 0x08[6]    |
|               |                      | 1:0 | Signal Detect<br>Status<br>De-assert<br>Threshold |      |         | Yes            | Status De-assert threshold (1010 pattern 12 Gbps)<br>00'b = 37 mVp-p (default)<br>01'b = 22 mVp-p<br>10'b = 55 mVp-p<br>11'b = 45 mVp-p<br>Note: Override SD_TH pin and enable register control<br>via Reg 0x08[6] |
| 0x45          | Reserved             | 7:0 | Reserved  | R/W  | 0x00    |                | Set bits to 0  |
| 0x46          | Reserved             | 7:0 | Reserved  | R/W  | 0x38    |                | Set bits to 0x38   |
| 0x47          | Reserved             | 7:4 | Reserved  | R/W  | 0x00    |                | Set bits to 0  |
|               |                      | 3:0 | Reserved  |      |         | Yes            | Set bits to 0  |
| 0x48          | Reserved             | 7:6 | Reserved  | R/W  | 0x05    | Yes            | Set bits to 0  |
|               |                      | 5:0 | Reserved  | R/W  |         |                | Set bits to 00 0101'b  |
| 0x49-<br>0x4B | Reserved             | 7:0 | Reserved  | R/W  | 0x00    |                | Set bits to 0  |
| 0x4C          | Reserved             | 7:3 | Reserved  | R/W  | 0x00    | Yes            | Set bits to 0  |
|               |                      | 2:1 | Reserved  | R/W  |         |                | Set bits to 0  |
|               |                      | 0   | Reserved  | R/W  |         | Yes            | Set bits to 0  |
| 0x4D-<br>0x50 | Reserved             | 7:0 | Reserved  | R/W  | 0x00    |                | Set bits to 0  |
| 0x51          | Device ID            | 7:5 | VERSION   | R    | 0x85    |                | 100'b  |
|               |                      | 4:0 | ID  |      |         |                | 0 0101'b   |
| 0x52-<br>0x55 | Reserved             | 7:0 | Reserved  | R/W  | 0x00    |                | Set bits to 0  |
| 0x56          | Reserved             | 7:0 | Reserved  | R/W  | 0x10    |                | Set bits to 0x10   |
| 0x57          | Reserved             | 7:0 | Reserved  | R/W  | 0x64    |                | Set bits to 0x64   |
| 0x58          | Reserved             | 7:0 | Reserved  | R/W  | 0x21    |                | Set bits to 0x21   |
| 0x59          | Reserved             | 7:1 | Reserved  | R/W  | 0x00    |                | Set bits to 0  |
|               |                      | 0   | Reserved  |      |         | Yes            | Set bit to 0   |
| 0x5A          | Reserved             | 7:0 | Reserved  | R/W  | 0x54    | Yes            | Set bits to 0x54   |
| 0x5B          | Reserved             | 7:0 | Reserved  | R/W  | 0x54    | Yes            | Set bits to 0x54   |
| 0x5C-<br>0x61 | Reserved             | 7:0 | Reserved  | R/W  | 0x00    |                | Set bits to 0  |

## 8 Applications and Implementation

### NOTE

Information in the following applications sections is not part of the TI component specification, and TI does not warrant its accuracy or completeness. TI's customers are responsible for determining suitability of components for their purposes. Customers should validate and test their design implementation to confirm system functionality.

### 8.1 Application Information

#### 8.1.1 Signal Integrity in 40G-CR4/KR4/SAS/SATA/PCIe Applications

In 40G-CR4/KR4/SAS/SATA/PCIe applications, specifications require Rx-Tx link training to establish and optimize signal conditioning settings for data rates up to 12.5 Gbps. In link training, the Rx partner requests a series of FIR coefficients from the Tx partner at speed. This polling sequence is designed to pre-condition the signal path with an optimized link between the endpoints. Link training occurs at the following data-rates:

**Table 10. Link Training Data-Rates**

| PROTOCOL <sup>(1)</sup> | OPERATING DATA RATE (Gbps) |
|-------------------------|----------------------------|
| 40G-CR4                 | 10.3125                    |
| 40G-KR4                 | 10.3125                    |
| SAS-3                   | 12.0                       |
| PCIe Gen-3              | 8.0                        |

(1) There is no link training with Tx FIR coefficients for the respective lower generation data rates.

The DS125BR820 works to extend the reach possible by using active linear equalization to the channel, boosting attenuated signals so that they can be more easily recovered at the Rx. The repeater outputs are specially designed to be transparent to Tx FIR signaling in order to pass information critical for optimal link training to the Rx. Suggested settings for the A-channels and B-channels are given in [Table 11](#) and [Table 12](#). Further adjustments to EQx and VODx settings may optimize signal margin on the link for different system applications:

**Table 11. Suggested Device Settings in Pin Mode**

| CHANNEL SETTINGS | PIN MODE       |
|------------------|----------------|
| EQx              | Level 1        |
| VODx[1:0]        | Level 6 (1, 0) |

**Table 12. Suggested Device Settings in SMBus Modes**

| CHANNEL SETTINGS | SMBus MODES |
|------------------|-------------|
| EQx              | 0x00        |
| VODx             | 110'b       |
| VOD_DB           | 000'b       |

The SMBus Slave Mode code example in [Table 13](#) may be used to program the DS125BR820 with the recommended device settings.

**Table 13. SMBus Example Sequence**

| REGISTER | WRITE VALUE | COMMENTS                              |
|----------|-------------|---------------------------------------|
| 0x06     | 0x18        | Set SMBus Slave Mode Register Enable. |
| 0x0F     | 0x00        | Set CHB_0 EQ to 0x00.                 |
| 0x10     | 0xAE        | Set CHB_0 VOD to 110'b.               |
| 0x11     | 0x00        | Set CHB_0 VOD_DB to 000'b.            |
| 0x16     | 0x00        | Set CHB_1 EQ to 0x00.                 |
| 0x17     | 0xAE        | Set CHB_1 VOD to 110'b.               |

**Table 13. SMBus Example Sequence (continued)**

| REGISTER | WRITE VALUE | COMMENTS                   |
|----------|-------------|----------------------------|
| 0x18     | 0x00        | Set CHB_1 VOD_DB to 000'b. |
| 0x1D     | 0x00        | Set CHB_2 EQ to 0x00.      |
| 0x1E     | 0xAE        | Set CHB_2 VOD to 110'b.    |
| 0x1F     | 0x00        | Set CHB_2 VOD_DB to 000'b. |
| 0x24     | 0x00        | Set CHB_3 EQ to 0x00.      |
| 0x25     | 0xAE        | Set CHB_3 VOD to 110'b.    |
| 0x26     | 0x00        | Set CHB_3 VOD_DB to 000'b. |
| 0x2C     | 0x00        | Set CHA_0 EQ to 0x00.      |
| 0x2D     | 0xAE        | Set CHA_0 VOD to 110'b.    |
| 0x2E     | 0x00        | Set CHA_0 VOD_DB to 000'b. |
| 0x33     | 0x00        | Set CHA_1 EQ to 0x00.      |
| 0x34     | 0xAE        | Set CHA_1 VOD to 110'b.    |
| 0x35     | 0x00        | Set CHA_1 VOD_DB to 000'b. |
| 0x3A     | 0x00        | Set CHA_2 EQ to 0x00.      |
| 0x3B     | 0xAE        | Set CHA_2 VOD to 110'b.    |
| 0x3C     | 0x00        | Set CHA_2 VOD_DB to 000'b. |
| 0x41     | 0x00        | Set CHA_3 EQ to 0x00.      |
| 0x42     | 0xAE        | Set CHA_3 VOD to 110'b.    |
| 0x43     | 0x00        | Set CHA_3 VOD_DB to 000'b. |

**8.1.2 Signal Integrity in 40G-SR4/LR4 Applications**

In 40G-SR4/LR4 applications, the ideal device settings must be tuned. In particular, EQ and VOD settings must be optimized in order to aid the link partners in meeting the nPPI eye mask test. While tuning the DS125BR820 contributes to signal quality improvement, it is equally important to ensure that the link partner ASIC Tx FIR signal characteristics are optimized as well to facilitate error-free data transmission. Suggested settings for the A-channels and B-channels in a 40G-SR4/LR4 environment can be referenced in [Table 11](#) and [Table 12](#).

**8.1.3 Rx Detect Functionality in 40G-CR4/KR4/SAS/SATA Applications**

Unlike PCIe systems, 40G-CR4/KR4/SAS/SATA systems use a low speed communications sequence to detect and communicate device capabilities between host ASIC and link partners. This communication eliminates the need to detect for endpoints like in a PCIe application. For 40G-CR4/KR4/SAS/SATA systems, it is recommended to tie the RXDET pin high. This ensures any link-training sequences sent by the host ASIC can reach the link partner receiver without any additional latency due to termination detection sequences.

**8.2 Typical Applications**

**8.2.1 Generic High Speed Repeater**

The DS125BR820 extends PCB and cable reach in multiple applications by using active linear equalization. The high linearity of this device aids specifically in protocols requiring link training and can be used in line cards, backplanes, motherboards, and active cable assemblies, thereby improving margin and overall eye performance. The capability of the repeater can be explored across a range of data rates and ASIC-to-link-partner signaling, as shown in the following two test setup connections.

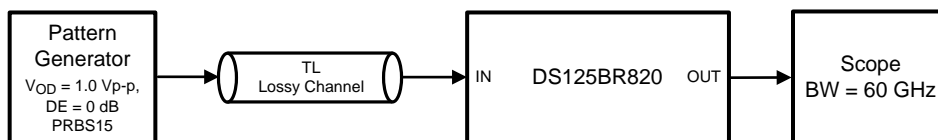

**Figure 9. Test Setup Connections Diagram**

## Typical Applications (continued)



Figure 10. Test Setup Connections Diagram

### 8.2.1.1 Design Requirements

As with any high speed design, there are many factors which influence the overall performance. Below are a list of critical areas for consideration and study during design.

- Use 100  $\Omega$  impedance traces. Generally these are very loosely coupled to ease routing length differences.
- Place AC-coupling capacitors near to the receiver end of each channel segment to minimize reflections.
- The maximum body size for AC-coupling capacitors is 0402.
- Back-drill connector vias and signal vias to minimize stub length.
- Use Reference plane vias to ensure a low inductance path for the return current.

### 8.2.1.2 Detailed Design Procedure

The DS125BR820 is designed to be placed at an offset location with respect to the overall channel attenuation. In order to optimize performance, the repeater requires tuning to extend the reach of the cable or trace length while also recovering a solid eye opening. To tune the repeater, the settings mentioned in Table 11 (for Pin Mode) and Table 12 (for SMBus Modes) are recommended as a default starting point for most applications. Once these settings are configured, additional tuning of the EQ and, to a lesser extent, VOD may be required to optimize the repeater performance for each specific application environment.

Examples of the repeater performance as a generic high speed datapath repeater are illustrated in the performance curves in the next section.

### 8.2.1.3 Application Performance Plots

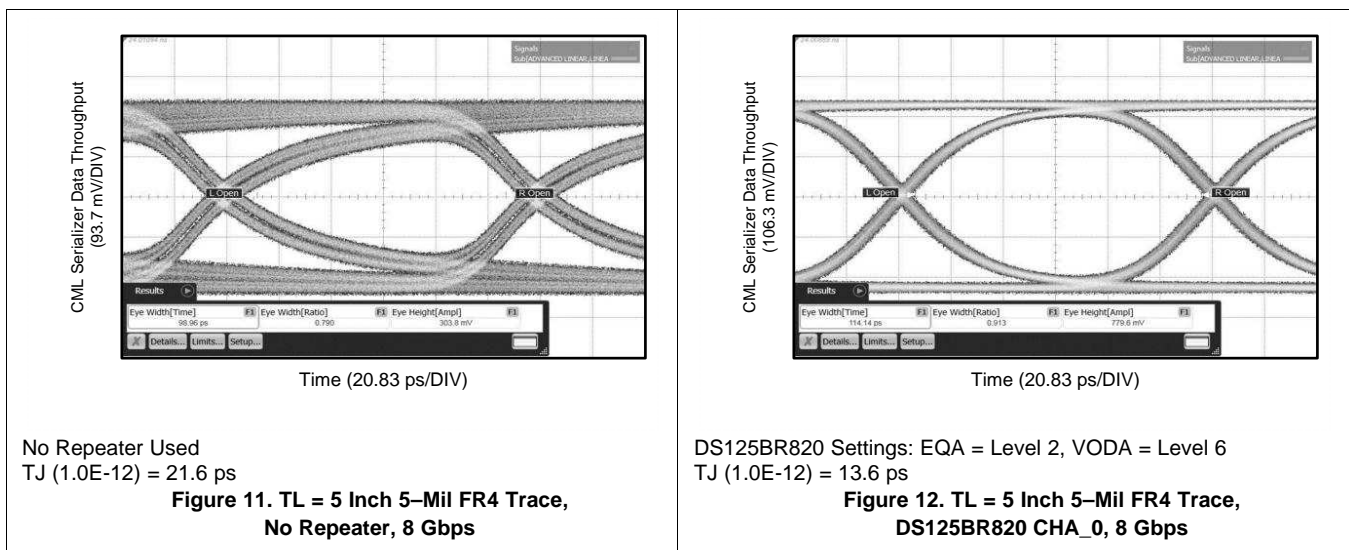

Typical Applications (continued)

CML Serializer Data Throughput  
(91.9 mV/DIV)

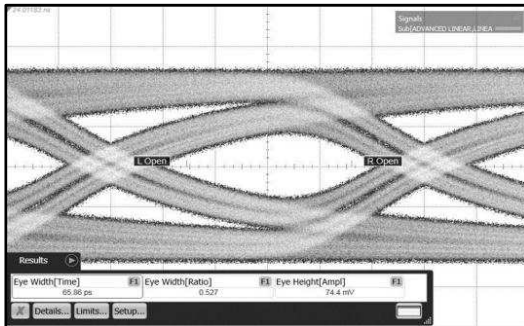

Time (20.83 ps/DIV)

No Repeater Used  
TJ (1.0E-12) = 43.7 ps

Figure 13. TL = 10 Inch 5-Mil FR4 Trace, No Repeater, 8 Gbps

CML Serializer Data Throughput  
(109.75 mV/DIV)

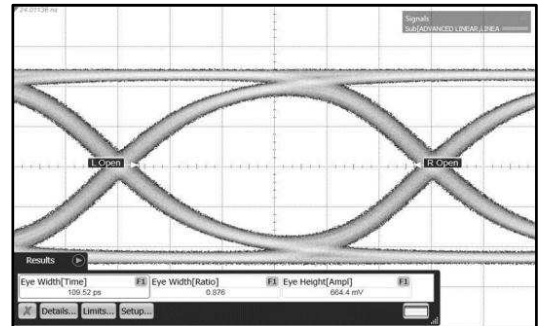

Time (20.83 ps/DIV)

DS125BR820 Settings: EQA = Level 3, VODA = Level 6  
TJ (1.0E-12) = 18.1 ps

Figure 14. TL = 10 Inch 5-Mil FR4 Trace, DS125BR820 CHA\_0, 8 Gbps

CML Serializer Data Throughput  
(89.35 mV/DIV)

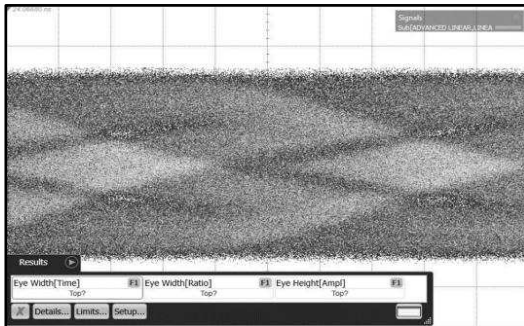

Time (20.83 ps/DIV)

No Repeater Used  
TJ (1.0E-12) = Not Available Due to Closed Eye

Figure 15. TL = 20 Inch 5-Mil FR4 Trace, No Repeater, 8 Gbps

CML Serializer Data Throughput  
(106.35 mV/DIV)

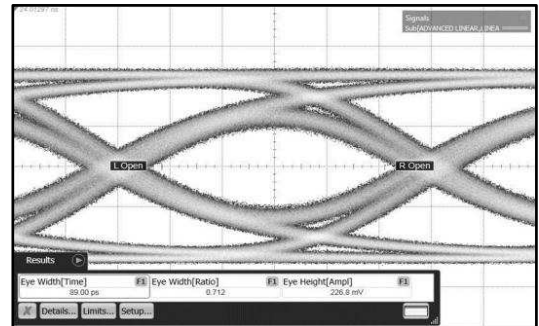

Time (20.83 ps/DIV)

DS125BR820 Settings: EQA = Level 4, VODA = Level 6  
TJ (1.0E-12) = 35.5 ps

Figure 16. TL = 20 Inch 5-Mil FR4 Trace, DS125BR820 CHA\_0, 8 Gbps

CML Serializer Data Throughput  
(73.25 mV/DIV)

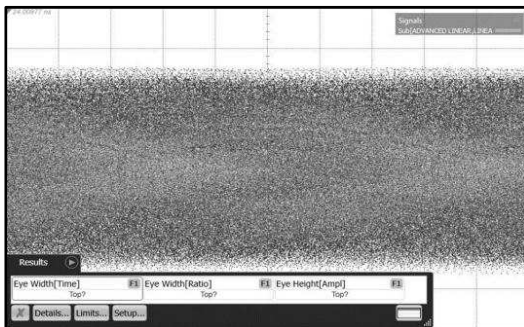

Time (20.83 ps/DIV)

No Repeater  
TJ (1.0E-12) = Not Available Due to Closed Eye

Figure 17. TL = 5-Meter 30-AWG 100 Ω Twin-Axial Cable, No Repeater, 8 Gbps

CML Serializer Data Throughput  
(89.95 mV/DIV)

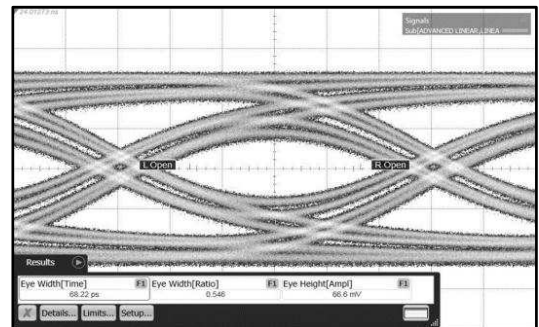

Time (20.83 ps/DIV)

DS125BR820 Settings: EQA = Level 4, VODA = Level 6  
TJ (1.0E-12) = 41.4 ps

Figure 18. TL = 5-Meter 30-AWG 100 Ω Twin-Axial Cable, DS125BR820 CHA\_0, 8 Gbps

Typical Applications (continued)

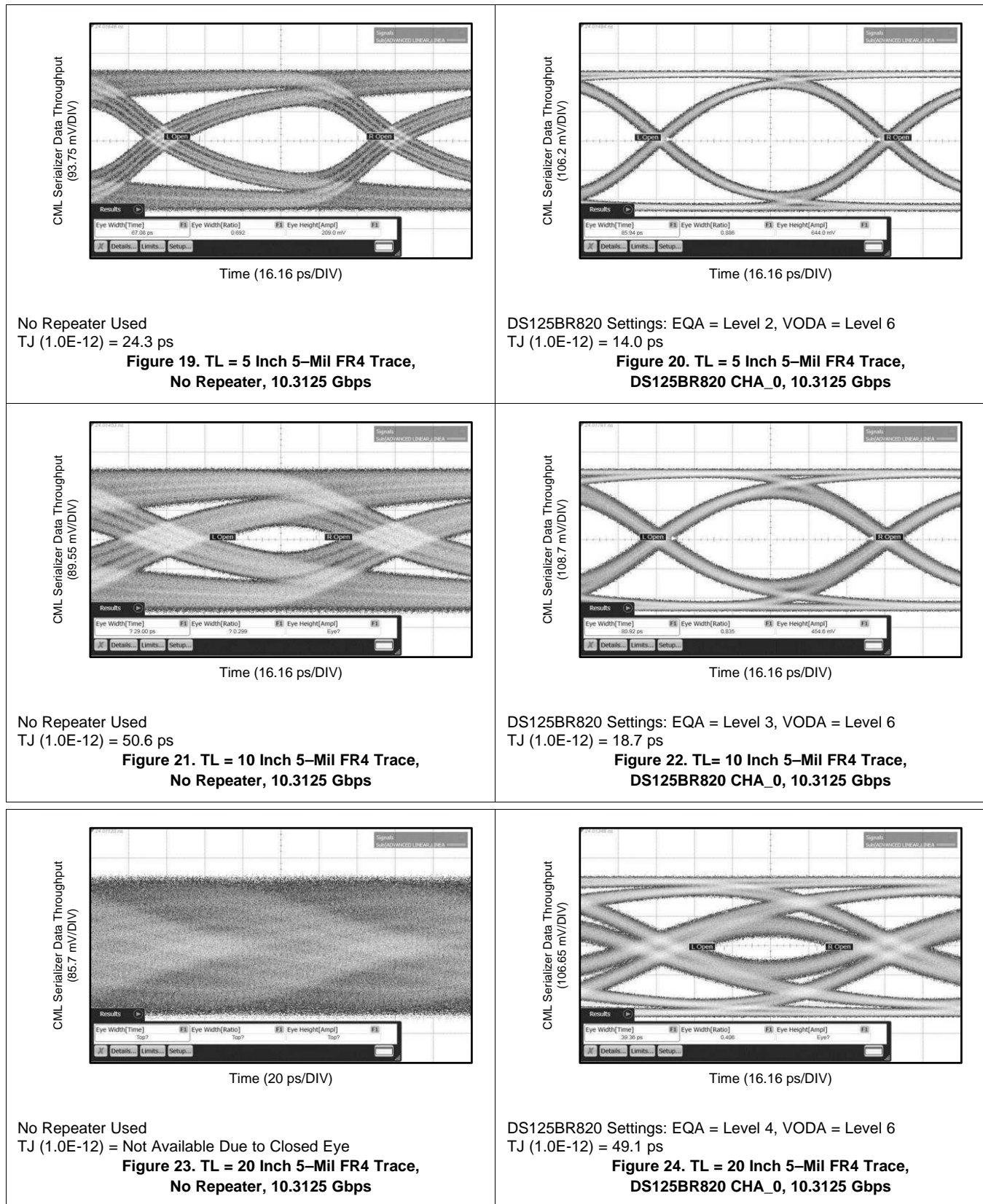

Typical Applications (continued)

CML Serializer Data Throughput  
(93.1 mV/DIV)

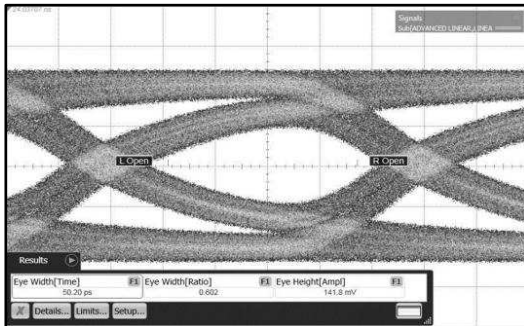

Time (13.89 ps/DIV)

No Repeater  
TJ (1.0E-12) = 26.1 ps

Figure 25. TL = 5 Inch 5-Mil FR4 Trace,  
No Repeater, 12 Gbps

CML Serializer Data Throughput  
(106.15 mV/DIV)

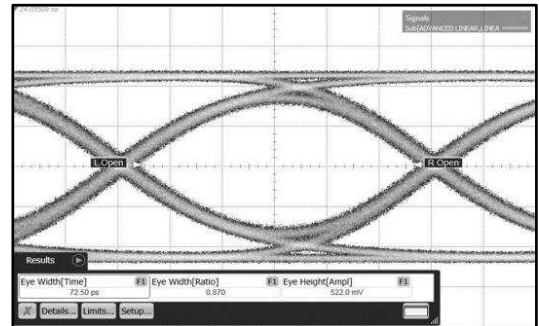

Time (13.89 ps/DIV)

DS125BR820 Settings: EQA = Level 2, VODA = Level 6  
TJ (1.0E-12) = 13.1 ps

Figure 26. TL = 5 Inch 5-Mil FR4 Trace,  
DS125BR820 CHA\_0, 12 Gbps

CML Serializer Data Throughput  
(88.95 mV/DIV)

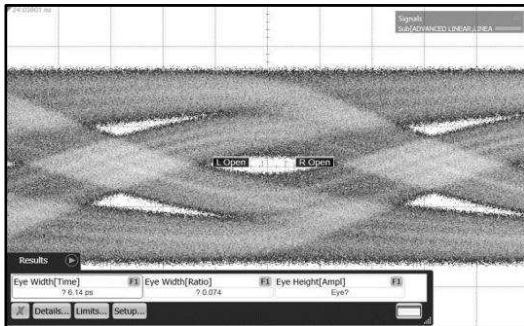

Time (13.89 ps/DIV)

No Repeater  
TJ (1.0E-12) = 56.6 ps

Figure 27. TL = 10 Inch 5-Mil FR4 Trace,  
No Repeater, 12 Gbps

CML Serializer Data Throughput  
(109.8 mV/DIV)

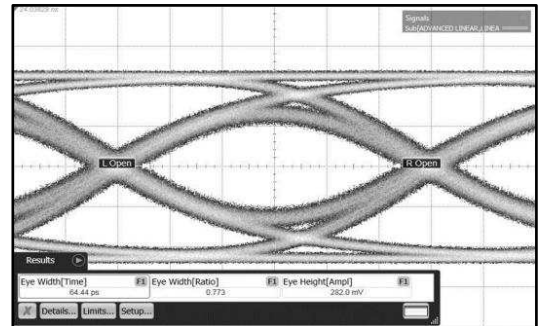

Time (13.89 ps/DIV)

DS125BR820 Settings: EQA = Level 3, VODA = Level 6  
TJ (1.0E-12) = 20.1 ps

Figure 28. TL = 10 Inch 5-Mil FR4 Trace,  
DS125BR820 CHA\_0, 12 Gbps

CML Serializer Data Throughput  
(46.05 mV/DIV)

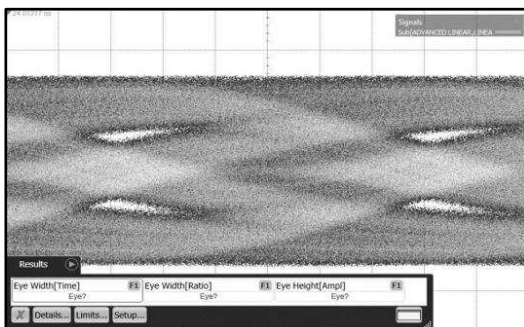

Time (20.83 ps/DIV)

No Repeater Used  
TJ (1.0E-12) = Not Available Due to Closed Eye

Figure 29. TL1 = 15 Inch 5-Mil FR4 Trace,  
TL2 = 10 Inch 5-Mil FR4 Trace,  
No Repeater, 8 Gbps

CML Serializer Data Throughput  
(63.7 mV/DIV)

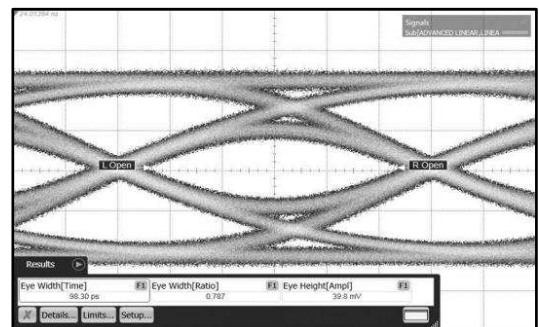

Time (20.83 ps/DIV)

DS125BR820 Settings: EQA = Level 4, VODA = Level 6  
TJ (1.0E-12) = 33.0 ps

Figure 30. TL1 = 15 Inch 5-Mil FR4 Trace,  
TL2 = 10 Inch 5-Mil FR4 Trace,  
DS125BR820 CHA\_0, 8 Gbps

Typical Applications (continued)

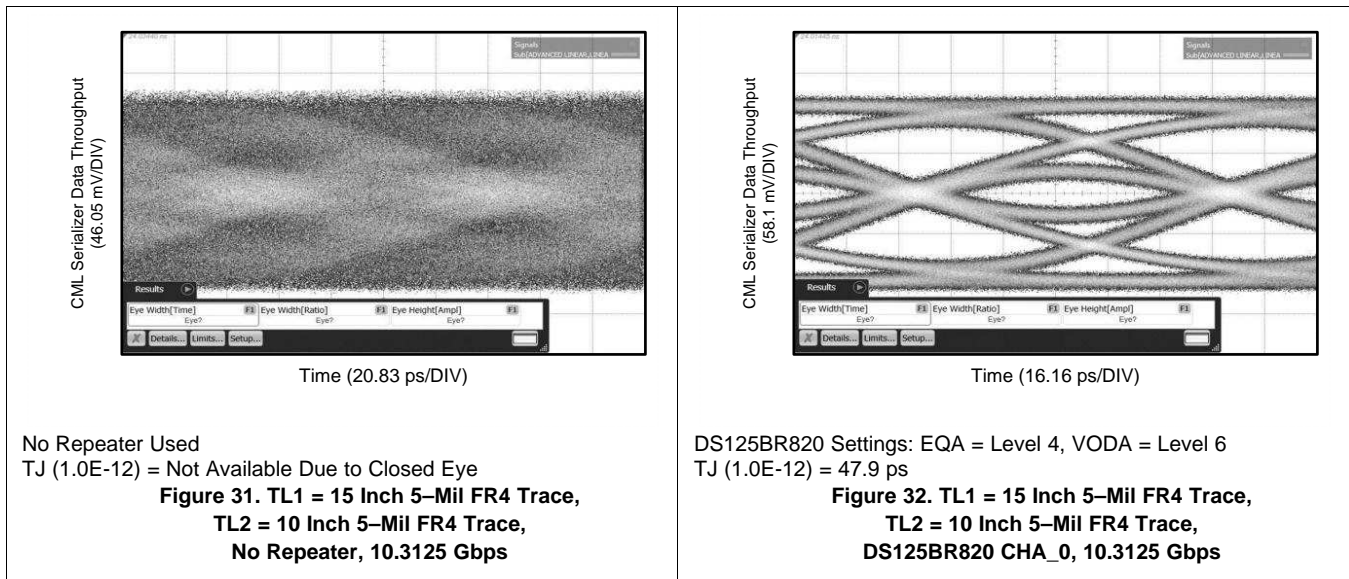

8.2.2 Front Port Applications (40G-CR4/SR4/LR4)

The DS125BR820 can be used in front port applications to extend the reach between the host ASIC and the front-port cage. Front port applications typically include 40G-CR4/SR4/LR4. For 40GbE front port optical protocols like 40G-SR4/LR4, the DS125BR820 is designed to support the front-port eye mask and jitter requirements of applicable standards like nPPI. For 40GbE front port copper protocols like 40G-CR4, the DS125BR820 is designed to provide channel equalization in a transparent fashion so as not to inhibit IEEE802.3ba Clause 72 link training. In all of these front port cases, the DS125BR820 can also be used to support eye mask and jitter requirements for SFF-8431 if the 40GbE QSFP+ port is intended to support 4x10G SFP+ applications as well. Below is a typical example of the DS125BR820 used in a front port line-card application.

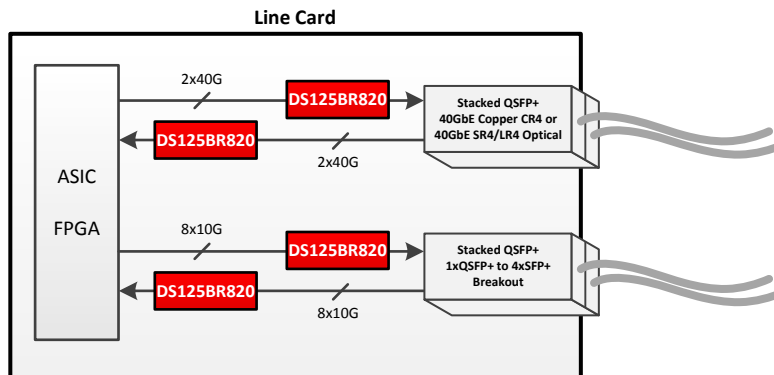

Figure 33. Typical Front-Port System Configuration

8.2.2.1 Design Requirements

As with any high speed design, there are many factors that influence the overall performance. Please reference [Design Requirements](#) in the [Generic High Speed Repeater](#) application section for a list of critical areas for consideration and study during design.

## Typical Applications (continued)

### 8.2.2.2 Detailed Design Procedure

In front port applications, it is important to ensure that the placement of the DS125BR820 corresponds with the direction of the data flow, since the device is unidirectional. For egress applications, the DS125BR820 should be placed close to the connector cage, and for ingress applications, the DS125BR820 should be placed closer to the switch ASIC. Once the DS125BR820 placement is decided on the signal path, the repeater must be tuned. To tune the repeater, the settings mentioned in [Table 11](#) (for Pin Mode) and [Table 12](#) (for SMBus Modes) are recommended as a default starting point for most applications. Once these settings are configured, additional tuning of the EQ and, to a lesser extent, VOD may be required to optimize the repeater performance in order to meet the link training requirements for 40G-CR4 and eye mask requirements for 40G-SR4/LR4.

An example of a test configuration used to evaluate the DS125BR820 in this application can be seen in [Figure 34](#). For more information about DS125BR820 front port applications, please refer to application note [SNLA226](#):

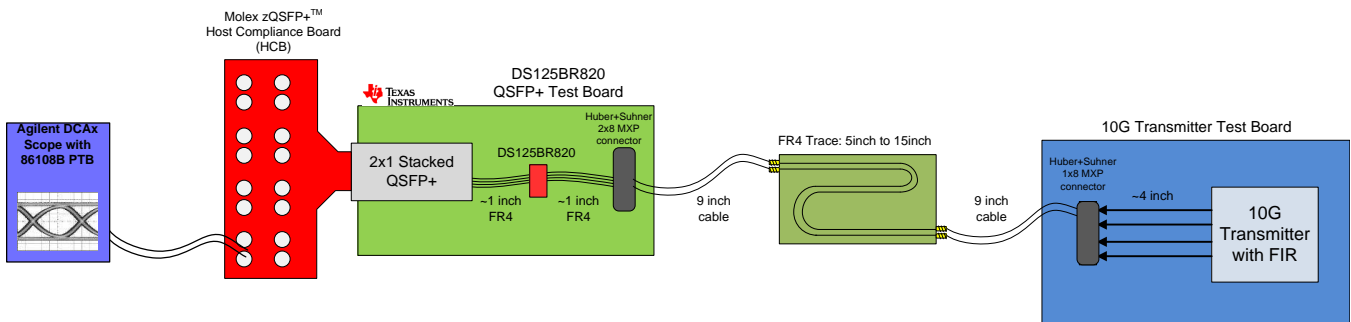

Figure 34. 10 GbE Transmitter with DS125BR820 QSFP+ Test Board

### 8.2.2.3 Application Performance Plots

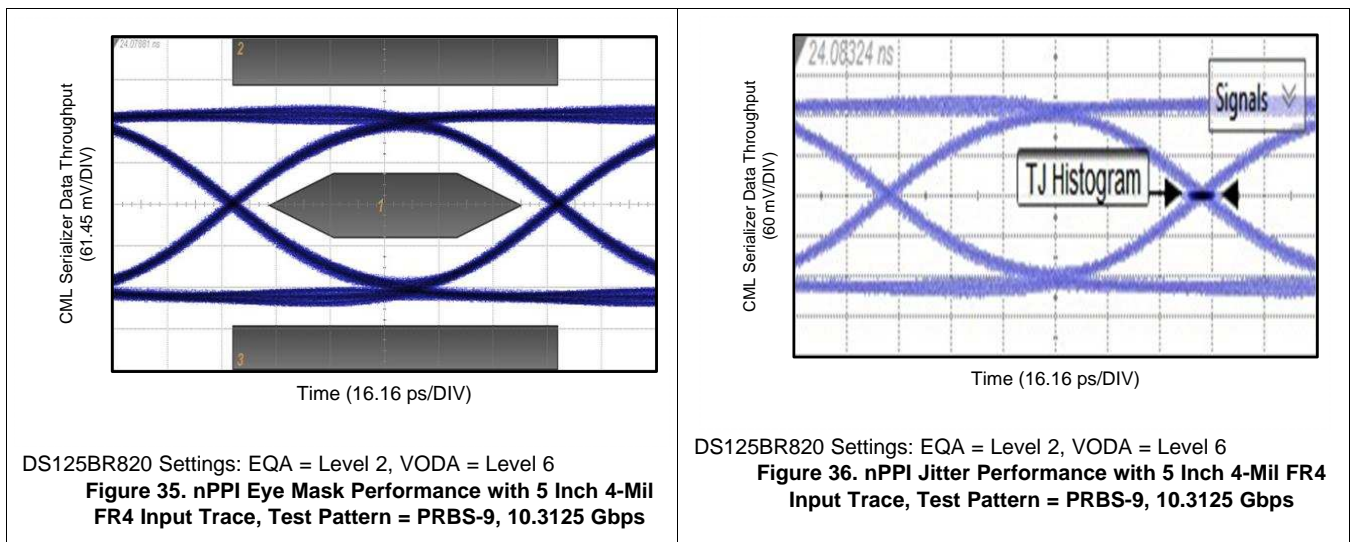
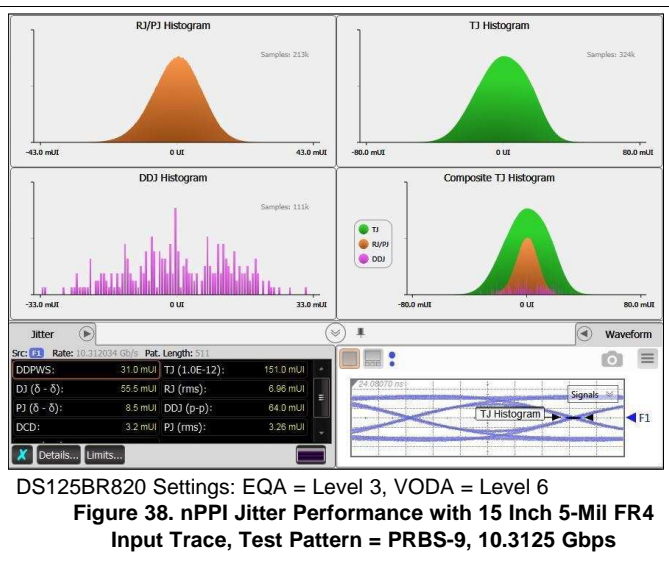
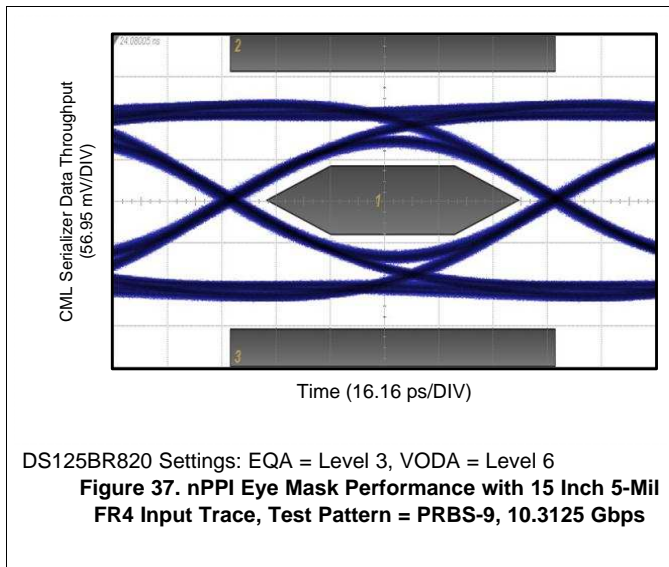

Figure 35. nPPI Eye Mask Performance with 5 Inch 4-Mil FR4 Input Trace, Test Pattern = PRBS-9, 10.3125 Gbps

Figure 36. nPPI Jitter Performance with 5 Inch 4-Mil FR4 Input Trace, Test Pattern = PRBS-9, 10.3125 Gbps

Typical Applications (continued)



8.2.3 PCIe Board Applications (PCIe Gen-3)

The DS125BR820 can be used to extend trace length on motherboards and line cards in PCIe Gen-3 applications. The high linearity of the DS125BR820 aids in the link training protocol required by PCIe Gen-3 at 8 Gbps in accordance with PCI-SIG standards. For PCIe Gen-3, preservation of the pre-cursor and post-cursor Tx FIR presets (P1-P10) is crucial to successful signal transmission from motherboard system root complex to line card ASIC or Embedded Processor. Below is a typical example of the DS125BR820 used in a PCIe application:

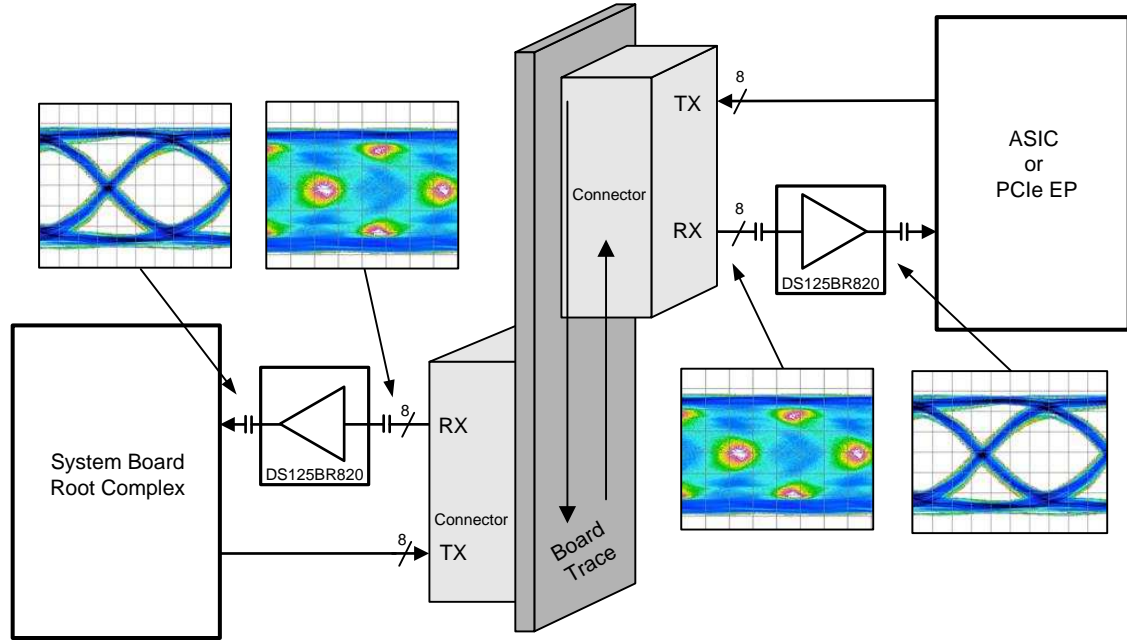

Figure 39. Typical PCIe Gen-3 Configuration Diagram

8.2.3.1 Design Requirements

As with any high speed design, there are many factors that influence the overall performance. Please reference [Design Requirements](#) in the [Generic High Speed Repeater](#) application section for a list of critical areas for consideration and study during design.

## Typical Applications (continued)

### 8.2.3.2 Design Procedure

In PCIe Gen-3 applications, there is a large range of flexibility regarding the placement of the DS125BR820 in the signal path due to the high linearity of the device. If the PCIe slot must also support lower speeds like PCIe Gen-1 (2.5 Gbps) and Gen-2 (5.0 Gbps), it is recommended to place the DS125BR820 closer to the endpoint Rx. Once the DS125BR820 is placed on the signal path, the repeater must be tuned. To tune the repeater, the settings mentioned in [Table 11](#) (for Pin Mode) and [Table 12](#) (for SMBus Modes) are recommended as a default starting point for most applications. Once these settings are configured, additional tuning of the EQ and, to a lesser extent, VOD may be required to optimize the repeater performance to pass link training preset requirements for PCIe Gen-3.

An example of a test configuration used to evaluate the DS125BR820 in this application can be seen in [Figure 40](#). For more information about DS125BR820 PCIe applications, please refer to application note [SNLA227](#):

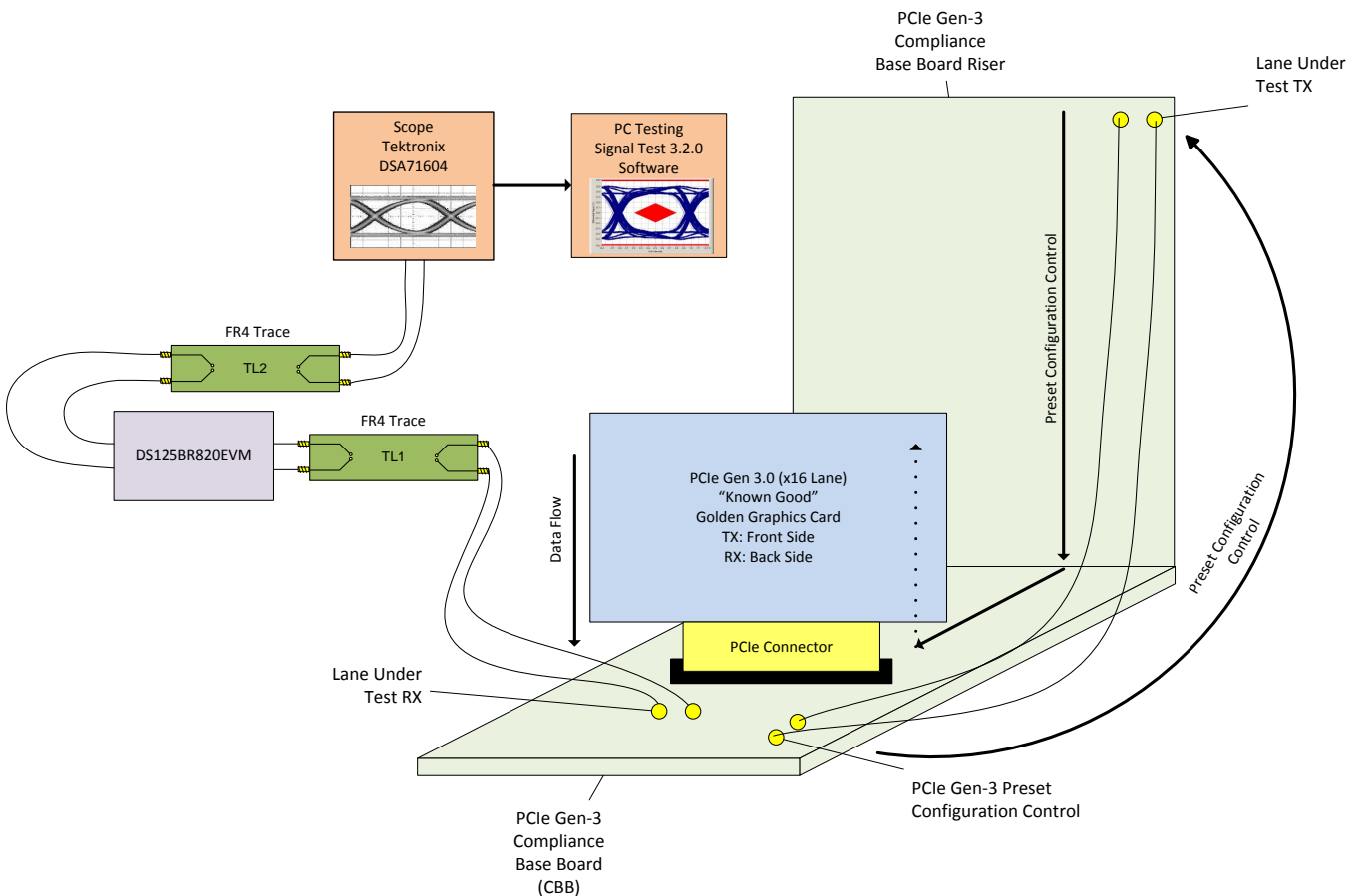
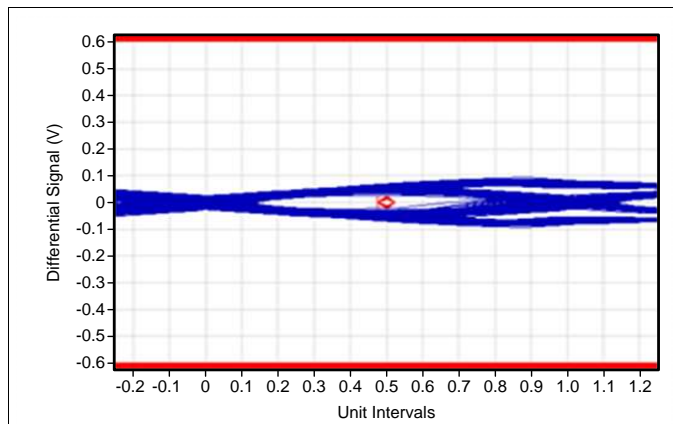

Figure 40. Typical PCIe Gen-3 Add-In Card Test Diagram

Typical Applications (continued)

8.2.3.3 Application Performance Plots



No Repeater Used  
 Composite Eye Height: 50.39 mV  
 Minimum Eye Width: 49.87 ps  
 Overall SigTest Result: Fail

**Figure 41. PCIe Gen-3, Preset 7, Transition Eye**  
 TL1 = 10 Inch 4-Mil FR4 Trace, No TL2  
 No Repeater, 8 Gbps

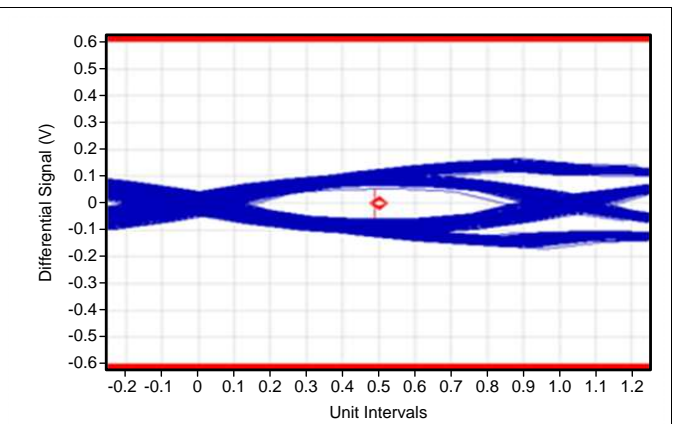

DS125BR820 Settings: EQA = Level 4, VODA = Level 6  
 Composite Eye Height: 112.2 mV  
 Minimum Eye Width: 83.82 ps  
 Overall SigTest Result: Pass

**Figure 42. PCIe Gen-3, Preset 7, Transition Eye**  
 TL1 = 10 Inch 4-Mil FR4 Trace, No TL2  
 DS125BR820, 8 Gbps

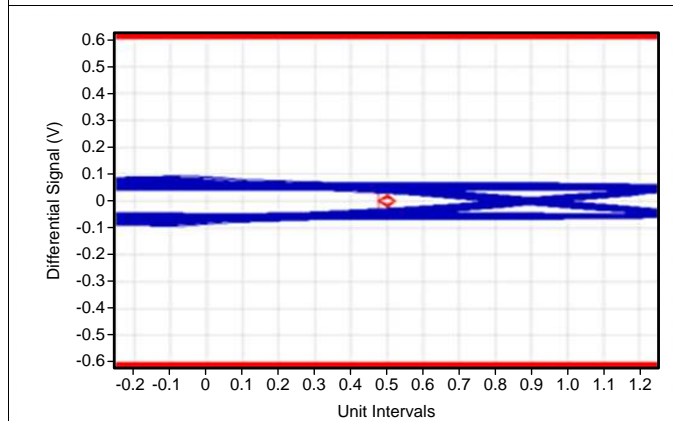

No Repeater Used  
 Composite Eye Height: 50.39 mV  
 Minimum Eye Width: 49.87 ps  
 Overall SigTest Result: Fail

**Figure 43. PCIe Gen-3, Preset 7, Non-Transition Eye**  
 TL1 = 10 Inch 4-Mil FR4 Trace, No TL2  
 No Repeater, 8 Gbps

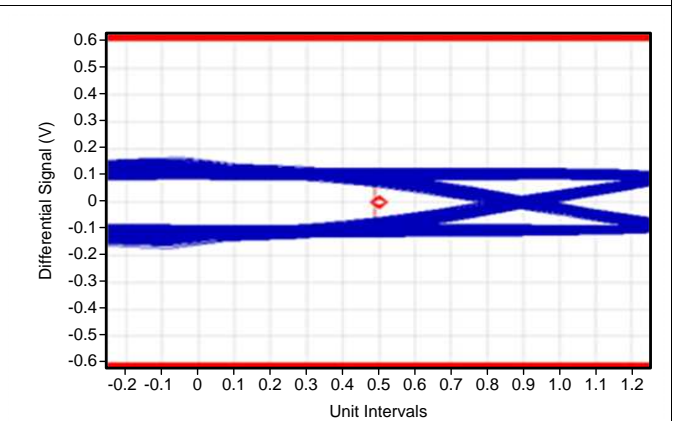

DS125BR820 Settings: EQA = Level 4, VODA = Level 6  
 Composite Eye Height: 112.2 mV  
 Minimum Eye Width: 83.82 ps  
 Overall SigTest Result: Pass

**Figure 44. PCIe Gen-3, Preset 7, Non-Transition Eye**  
 TL1 = 10 Inch 4-Mil FR4 Trace, No TL2  
 DS125BR820, 8 Gbps

Typical Applications (continued)

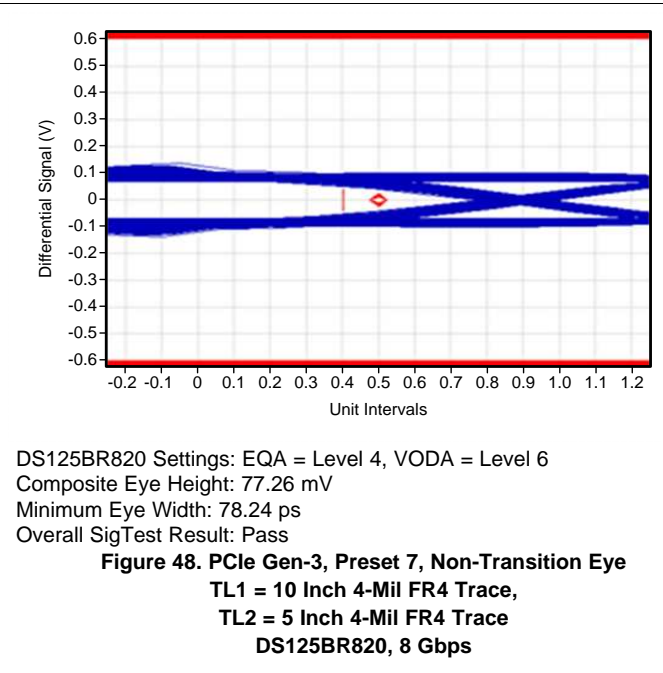
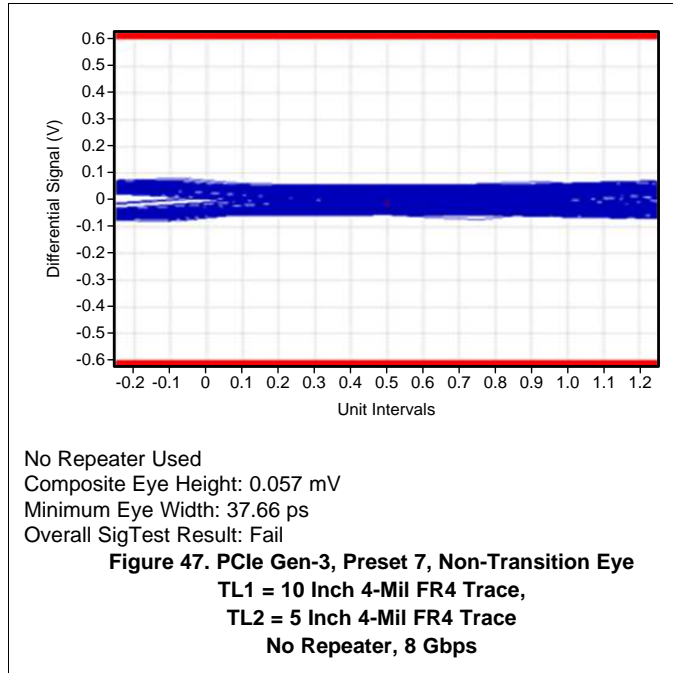
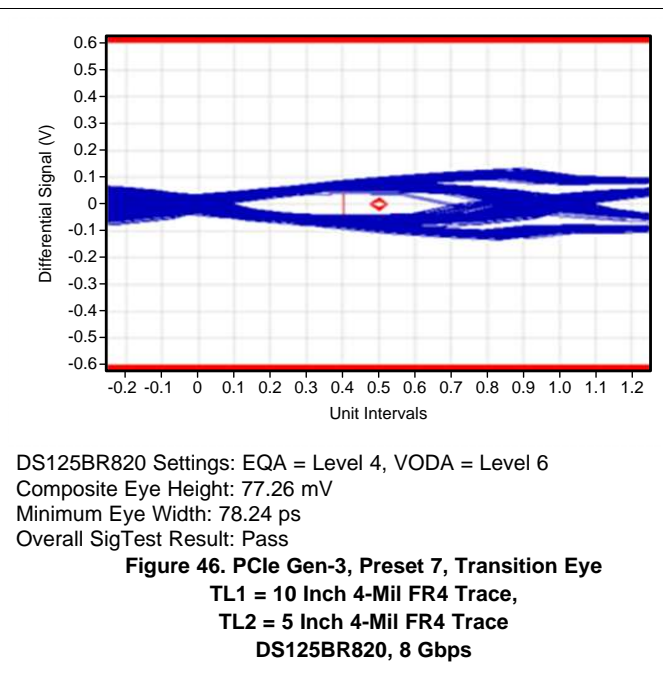
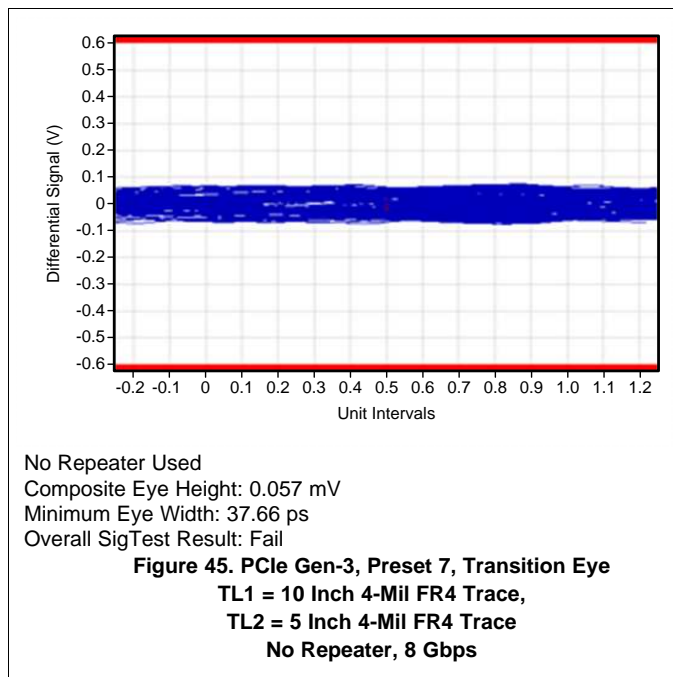

## 9 Power Supply Recommendations

Two approaches are recommended to ensure that the DS125BR820 is provided with an adequate power supply. First, the supply (VDD) and ground (GND) pins should be connected to power planes routed on adjacent layers of the printed circuit board. The layer thickness of the dielectric should be minimized so that the VDD and GND planes create a low inductance supply with distributed capacitance. Second, careful attention to supply bypassing through the proper use of bypass capacitors is required. A 0.1  $\mu\text{F}$  bypass capacitor should be connected to each VDD pin such that the capacitor is placed as close as possible to the DS125BR820. Smaller body size capacitors can help facilitate proper component placement. Additionally, capacitor with capacitance in the range of 1  $\mu\text{F}$  to 10  $\mu\text{F}$  should be incorporated in the power supply bypassing design as well. These capacitors can be either tantalum or an ultra-low ESR ceramic.

The DS125BR820 has an optional internal voltage regulator to provide the 2.5 V supply to the device. In 3.3 V mode operation, the VIN pin = 3.3 V is used to supply power to the device. The internal regulator then provides the 2.5 V to the VDD pins of the device and a 0.1  $\mu\text{F}$  cap is needed at each of the five VDD pins for power supply de-coupling (total capacitance should equal 0.5  $\mu\text{F}$ ). The VDD\_SEL pin must be tied to GND to enable the internal regulator. In 2.5 V mode operation, the VIN pin should be left open and 2.5 V supply must be applied to the five VDD pins to power the device. The VDD\_SEL pin must be left open (no connect) to disable the internal regulator.

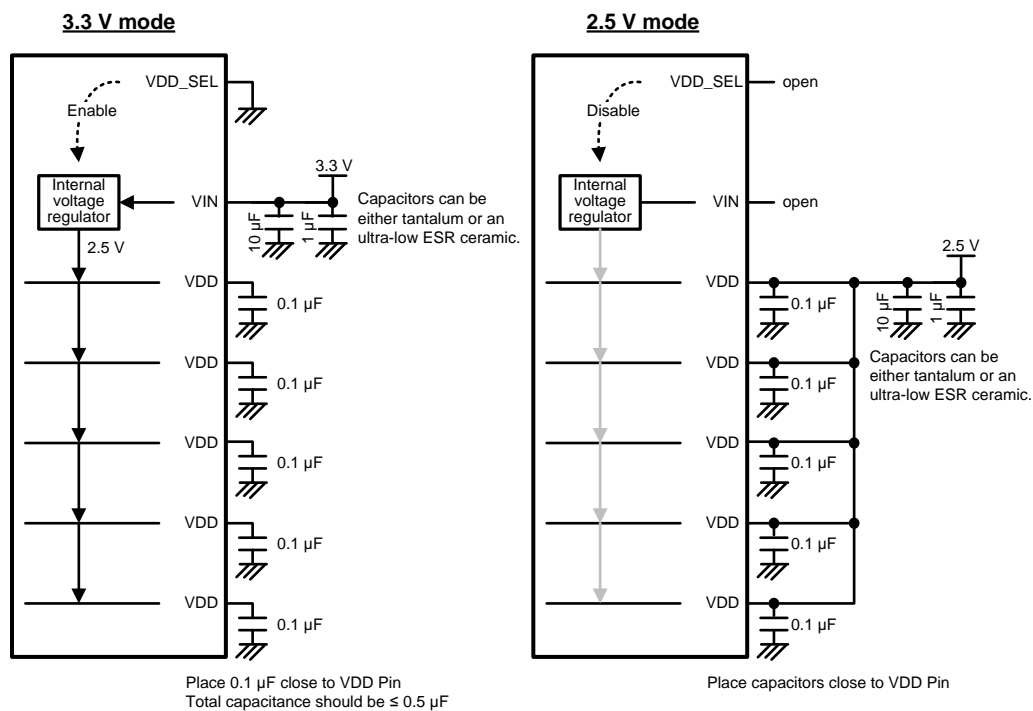

Figure 49. 3.3 V or 2.5 V Supply Connection Diagram

## 10 Layout

### 10.1 Layout Guidelines

The CML inputs and outputs have been optimized to work with interconnects using a controlled differential impedance of 100 Ω. It is preferable to route differential lines exclusively on one layer of the board, particularly for the input traces. The use of vias should be avoided if possible. If vias must be used, they should be used sparingly and must be placed symmetrically for each side of a given differential pair. Whenever differential vias are used the layout must also provide for a low inductance path for the return currents as well. Route the differential signals away from other signals and noise sources on the printed circuit board. To minimize the effects of crosstalk, a 5:1 ratio or greater should be maintained between inter-pair and intra-pair spacing. See AN-1187 “Leadless Leadframe Package (LLP) Application Report” (literature number [SNOA401](#)) for additional information on QFN (WQFN) packages.

### 10.2 Layout Example

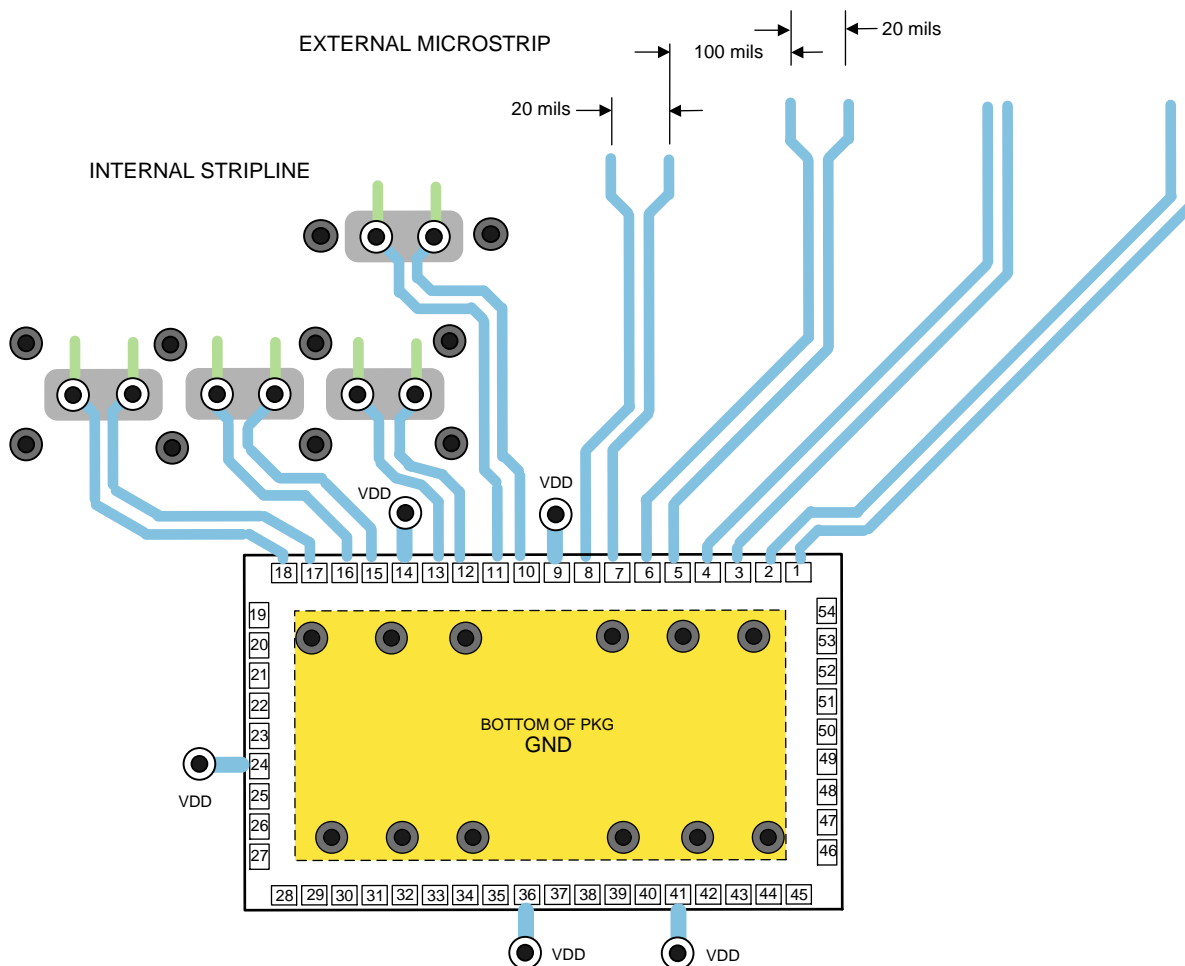

Figure 50. Typical Routing Options

The graphic shown above depicts different transmission line topologies which can be used in various combinations to achieve the optimal system performance. Impedance discontinuities at the differential via can be minimized or eliminated by increasing the swell around each hole and by providing for a low inductance return current path. When the via structure is associated with a thick backplane PCB, further optimization such as back drilling is often used to reduce the detrimental high frequency effects of stubs on the signal path.

## 11 Device and Documentation Support

### 11.1 Trademarks

All trademarks are the property of their respective owners.

### 11.2 Electrostatic Discharge Caution



These devices have limited built-in ESD protection. The leads should be shorted together or the device placed in conductive foam during storage or handling to prevent electrostatic damage to the MOS gates.

### 11.3 Glossary

[SLYZ022](#) — *TI Glossary*.

This glossary lists and explains terms, acronyms, and definitions.

## 12 Mechanical, Packaging, and Orderable Information

The following pages include mechanical, packaging, and orderable information. This information is the most current data available for the designated devices. This data is subject to change without notice and revision of this document. For browser-based versions of this data sheet, refer to the left-hand navigation.

**PACKAGING INFORMATION**

| Orderable Device | Status<br>(1) | Package Type | Package Drawing | Pins | Package Qty | Eco Plan<br>(2)         | Lead/Ball Finish<br>(6) | MSL Peak Temp<br>(3) | Op Temp (°C) | Device Marking<br>(4/5) | Samples                 |
|------------------|---------------|--------------|-----------------|------|-------------|-------------------------|-------------------------|----------------------|--------------|-------------------------|-------------------------|
| DS125BR820NJYR   | ACTIVE        | WQFN         | NJY             | 54   | 2000        | Green (RoHS & no Sb/Br) | CU SN                   | Level-2-260C-1 YEAR  | -40 to 85    | 125B820A0               | <a href="#">Samples</a> |
| DS125BR820NJYT   | ACTIVE        | WQFN         | NJY             | 54   | 250         | Green (RoHS & no Sb/Br) | CU SN                   | Level-2-260C-1 YEAR  | -40 to 85    | 125B820A0               | <a href="#">Samples</a> |

(1) The marketing status values are defined as follows:

**ACTIVE:** Product device recommended for new designs.

**LIFEBUY:** TI has announced that the device will be discontinued, and a lifetime-buy period is in effect.

**NRND:** Not recommended for new designs. Device is in production to support existing customers, but TI does not recommend using this part in a new design.

**PREVIEW:** Device has been announced but is not in production. Samples may or may not be available.

**OBSOLETE:** TI has discontinued the production of the device.

(2) Eco Plan - The planned eco-friendly classification: Pb-Free (RoHS), Pb-Free (RoHS Exempt), or Green (RoHS & no Sb/Br) - please check <http://www.ti.com/productcontent> for the latest availability information and additional product content details.

**TBD:** The Pb-Free/Green conversion plan has not been defined.

**Pb-Free (RoHS):** TI's terms "Lead-Free" or "Pb-Free" mean semiconductor products that are compatible with the current RoHS requirements for all 6 substances, including the requirement that lead not exceed 0.1% by weight in homogeneous materials. Where designed to be soldered at high temperatures, TI Pb-Free products are suitable for use in specified lead-free processes.

**Pb-Free (RoHS Exempt):** This component has a RoHS exemption for either 1) lead-based flip-chip solder bumps used between the die and package, or 2) lead-based die adhesive used between the die and leadframe. The component is otherwise considered Pb-Free (RoHS compatible) as defined above.

**Green (RoHS & no Sb/Br):** TI defines "Green" to mean Pb-Free (RoHS compatible), and free of Bromine (Br) and Antimony (Sb) based flame retardants (Br or Sb do not exceed 0.1% by weight in homogeneous material)

(3) MSL, Peak Temp. - The Moisture Sensitivity Level rating according to the JEDEC industry standard classifications, and peak solder temperature.

(4) There may be additional marking, which relates to the logo, the lot trace code information, or the environmental category on the device.

(5) Multiple Device Markings will be inside parentheses. Only one Device Marking contained in parentheses and separated by a "~" will appear on a device. If a line is indented then it is a continuation of the previous line and the two combined represent the entire Device Marking for that device.

(6) Lead/Ball Finish - Orderable Devices may have multiple material finish options. Finish options are separated by a vertical ruled line. Lead/Ball Finish values may wrap to two lines if the finish value exceeds the maximum column width.

**Important Information and Disclaimer:** The information provided on this page represents TI's knowledge and belief as of the date that it is provided. TI bases its knowledge and belief on information provided by third parties, and makes no representation or warranty as to the accuracy of such information. Efforts are underway to better integrate information from third parties. TI has taken and continues to take reasonable steps to provide representative and accurate information but may not have conducted destructive testing or chemical analysis on incoming materials and chemicals. TI and TI suppliers consider certain information to be proprietary, and thus CAS numbers and other limited information may not be available for release.

In no event shall TI's liability arising out of such information exceed the total purchase price of the TI part(s) at issue in this document sold by TI to Customer on an annual basis.

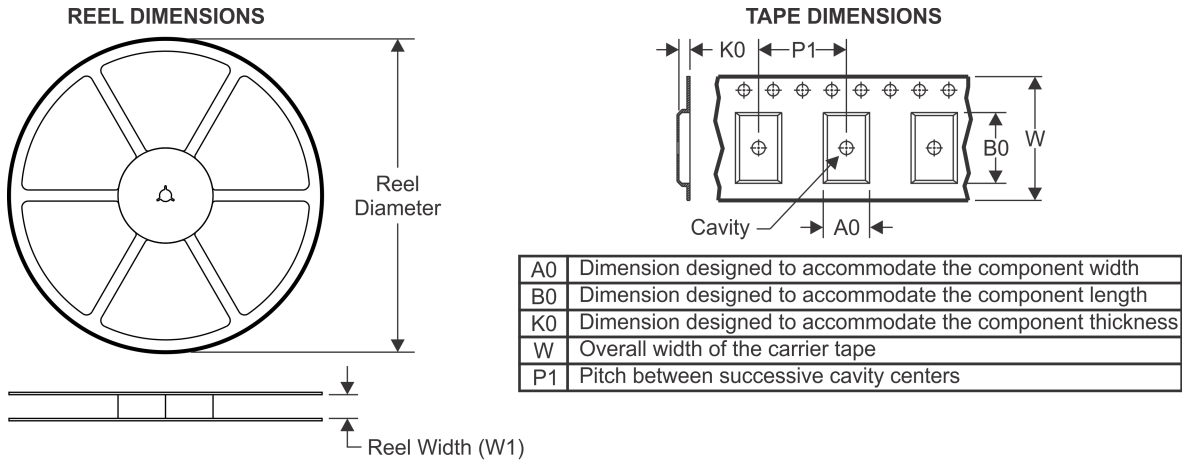
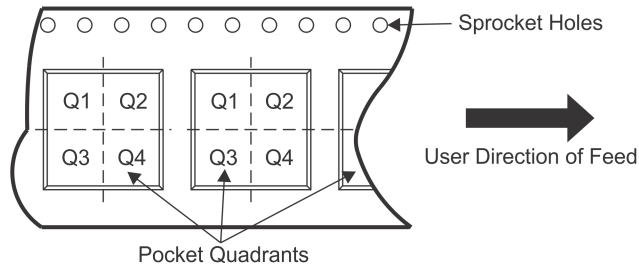
**TAPE AND REEL INFORMATION**

**QUADRANT ASSIGNMENTS FOR PIN 1 ORIENTATION IN TAPE**

\*All dimensions are nominal

| Device         | Package Type | Package Drawing | Pins | SPQ  | Reel Diameter (mm) | Reel Width W1 (mm) | A0 (mm) | B0 (mm) | K0 (mm) | P1 (mm) | W (mm) | Pin1 Quadrant |
|----------------|--------------|-----------------|------|------|--------------------|--------------------|---------|---------|---------|---------|--------|---------------|
| DS125BR820NJYR | WQFN         | NJY             | 54   | 2000 | 330.0              | 16.4               | 5.8     | 10.3    | 1.0     | 12.0    | 16.0   | Q1            |
| DS125BR820NJYT | WQFN         | NJY             | 54   | 250  | 178.0              | 16.4               | 5.8     | 10.3    | 1.0     | 12.0    | 16.0   | Q1            |

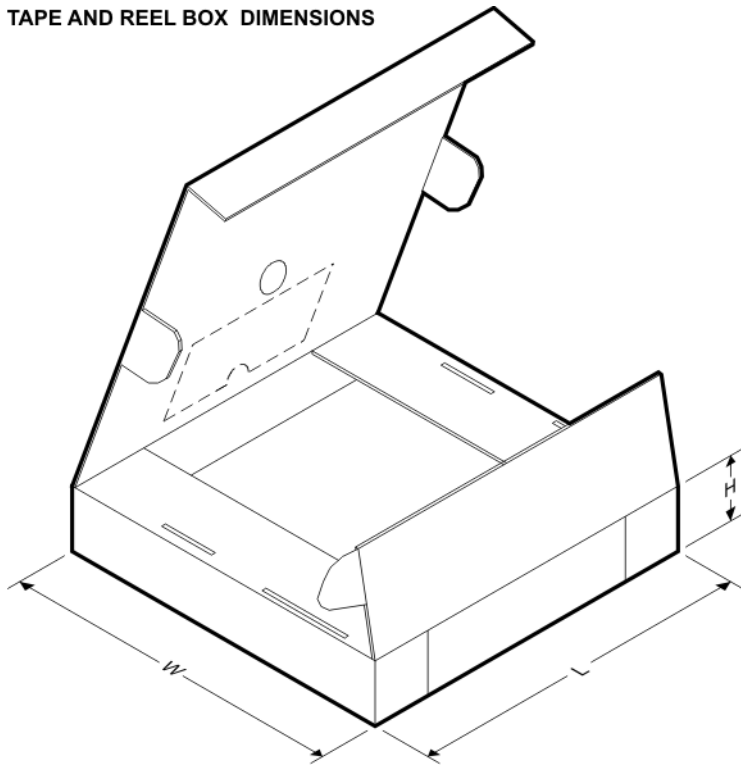
TAPE AND REEL BOX DIMENSIONS



\*All dimensions are nominal

| Device         | Package Type | Package Drawing | Pins | SPQ  | Length (mm) | Width (mm) | Height (mm) |
|----------------|--------------|-----------------|------|------|-------------|------------|-------------|
| DS125BR820NJYR | WQFN         | NJY             | 54   | 2000 | 367.0       | 367.0      | 38.0        |
| DS125BR820NJYT | WQFN         | NJY             | 54   | 250  | 210.0       | 185.0      | 35.0        |

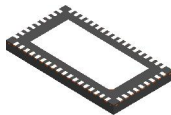

NJY0054A

WQFN

WQFN

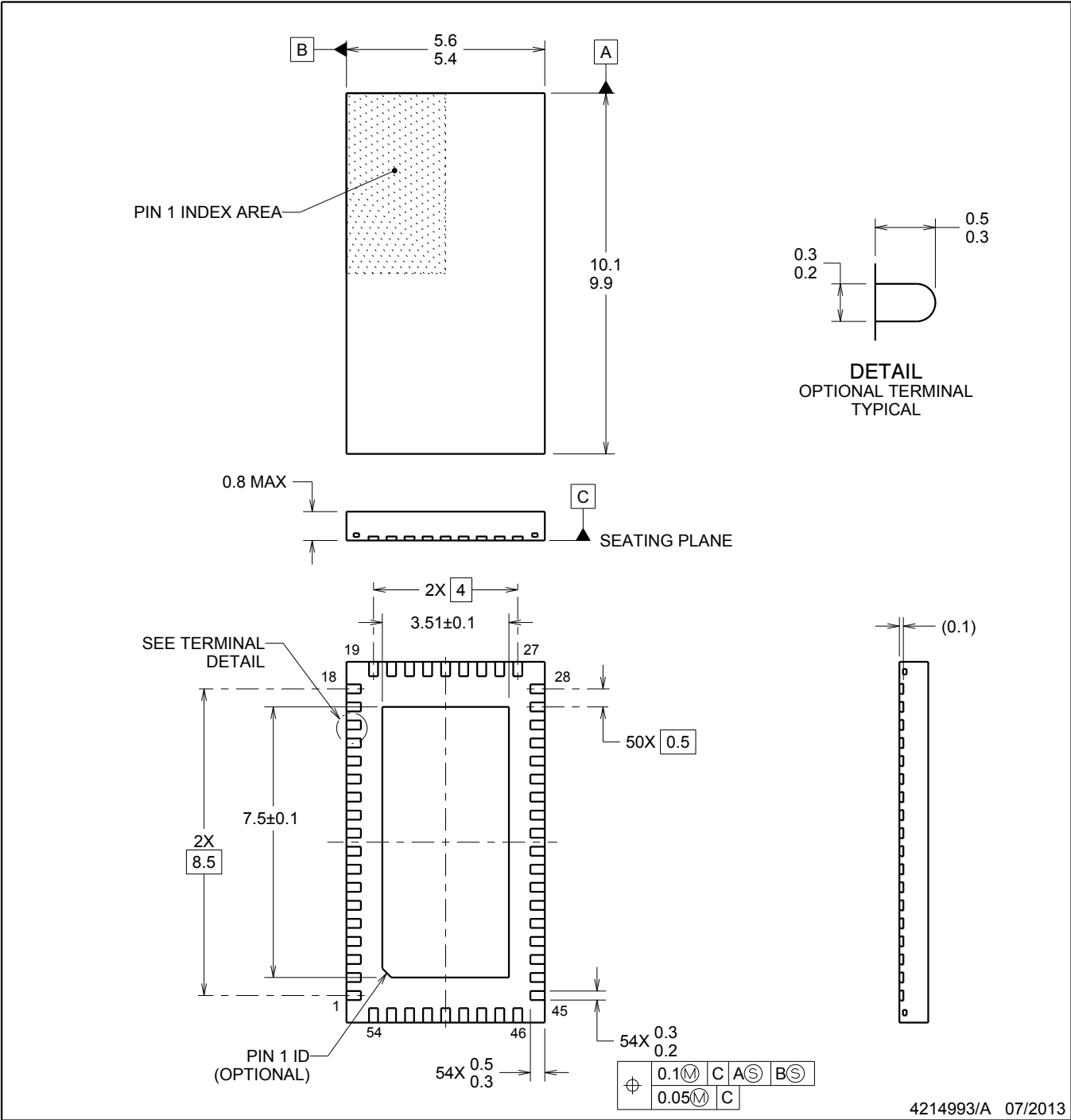

NOTES:

1. All linear dimensions are in millimeters. Dimensions in parenthesis are for reference only. Dimensioning and tolerancing per ASME Y14.5M.
2. This drawing is subject to change without notice.
3. The package thermal pad must be soldered to the printed circuit board for thermal and mechanical performance.

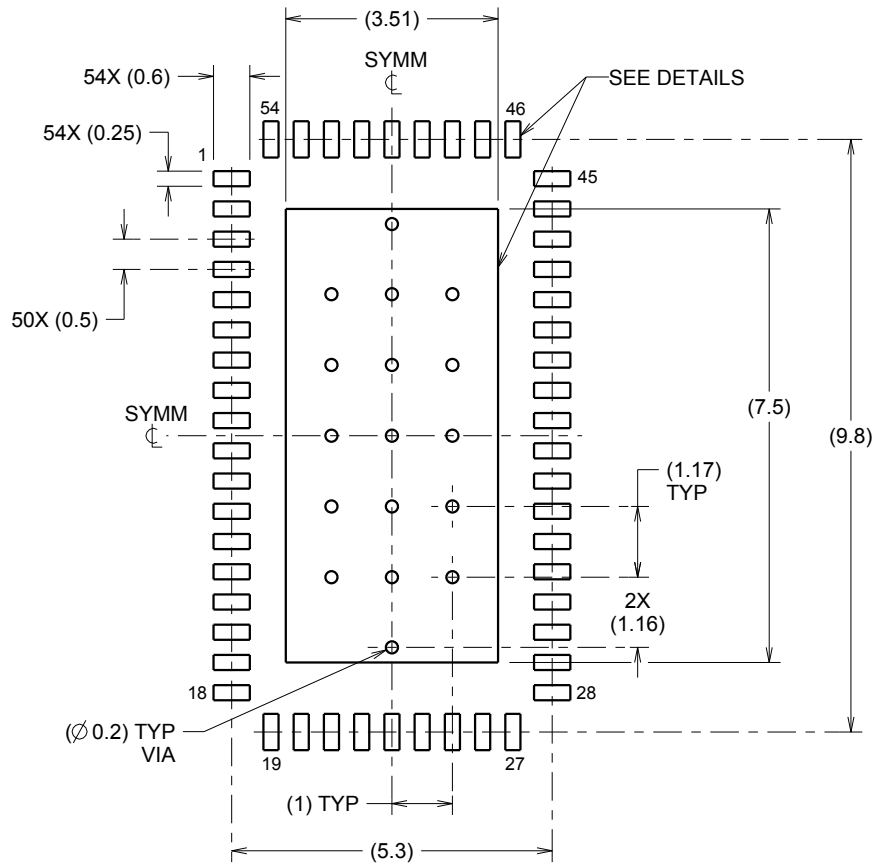

LAND PATTERN EXAMPLE  
SCALE:8X

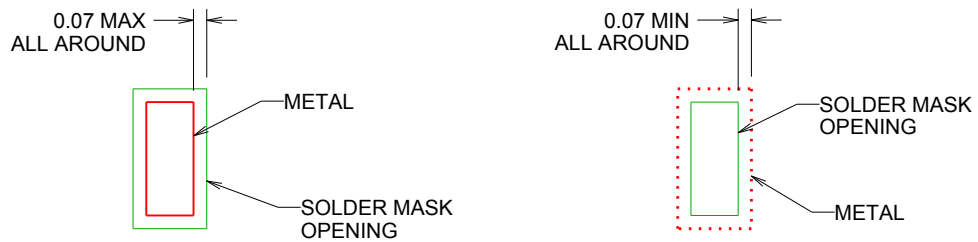

SOLDER MASK DETAILS

4214993/A 07/2013

NOTES: (continued)

- This package is designed to be soldered to a thermal pad on the board. For more information, refer to QFN/SON PCB application note in literature No. SLUA271 ([www.ti.com/lit/slua271](http://www.ti.com/lit/slua271)).

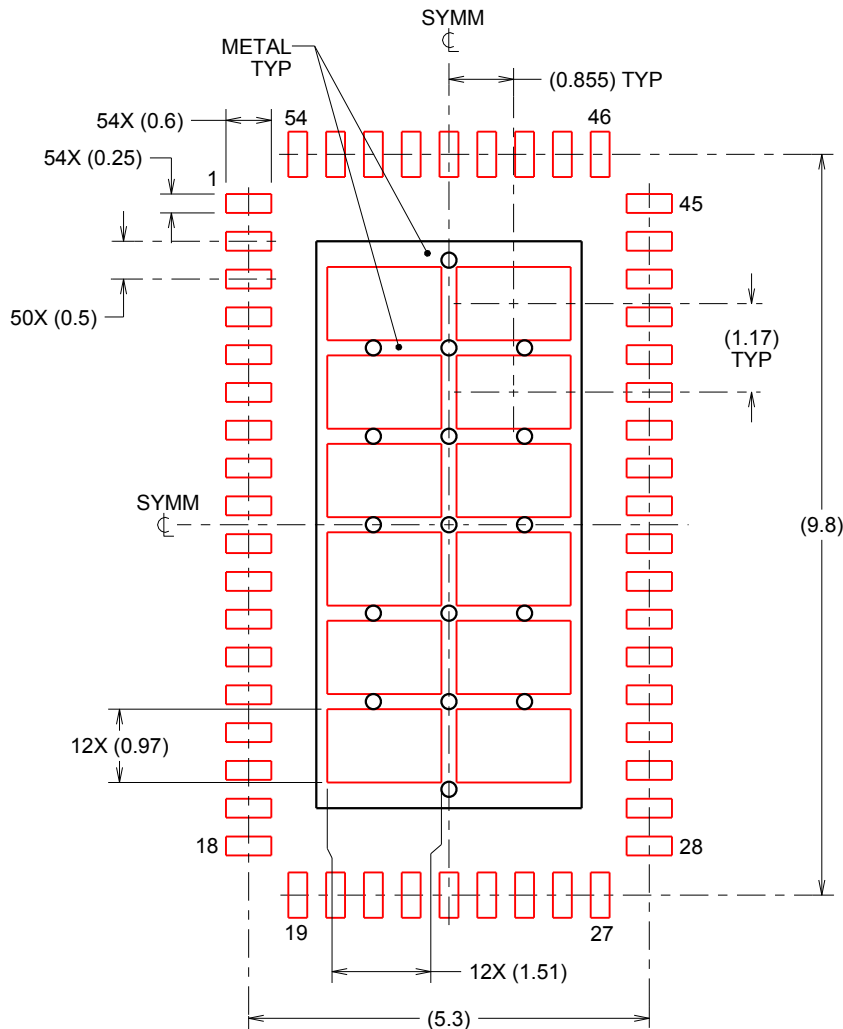

**SOLDERPASTE EXAMPLE**  
 BASED ON 0.125mm THICK STENCIL

EXPOSED PAD  
 67% PRINTED SOLDER COVERAGE BY AREA  
 SCALE:10X

4214993/A 07/2013

NOTES: (continued)

5. Laser cutting apertures with trapezoidal walls and rounded corners may offer better paste release. IPC-7525 may have alternate design recommendations.

## IMPORTANT NOTICE

Texas Instruments Incorporated and its subsidiaries (TI) reserve the right to make corrections, enhancements, improvements and other changes to its semiconductor products and services per JESD46, latest issue, and to discontinue any product or service per JESD48, latest issue. Buyers should obtain the latest relevant information before placing orders and should verify that such information is current and complete. All semiconductor products (also referred to herein as "components") are sold subject to TI's terms and conditions of sale supplied at the time of order acknowledgment.

TI warrants performance of its components to the specifications applicable at the time of sale, in accordance with the warranty in TI's terms and conditions of sale of semiconductor products. Testing and other quality control techniques are used to the extent TI deems necessary to support this warranty. Except where mandated by applicable law, testing of all parameters of each component is not necessarily performed.

TI assumes no liability for applications assistance or the design of Buyers' products. Buyers are responsible for their products and applications using TI components. To minimize the risks associated with Buyers' products and applications, Buyers should provide adequate design and operating safeguards.

TI does not warrant or represent that any license, either express or implied, is granted under any patent right, copyright, mask work right, or other intellectual property right relating to any combination, machine, or process in which TI components or services are used. Information published by TI regarding third-party products or services does not constitute a license to use such products or services or a warranty or endorsement thereof. Use of such information may require a license from a third party under the patents or other intellectual property of the third party, or a license from TI under the patents or other intellectual property of TI.

Reproduction of significant portions of TI information in TI data books or data sheets is permissible only if reproduction is without alteration and is accompanied by all associated warranties, conditions, limitations, and notices. TI is not responsible or liable for such altered documentation. Information of third parties may be subject to additional restrictions.

Resale of TI components or services with statements different from or beyond the parameters stated by TI for that component or service voids all express and any implied warranties for the associated TI component or service and is an unfair and deceptive business practice. TI is not responsible or liable for any such statements.

Buyer acknowledges and agrees that it is solely responsible for compliance with all legal, regulatory and safety-related requirements concerning its products, and any use of TI components in its applications, notwithstanding any applications-related information or support that may be provided by TI. Buyer represents and agrees that it has all the necessary expertise to create and implement safeguards which anticipate dangerous consequences of failures, monitor failures and their consequences, lessen the likelihood of failures that might cause harm and take appropriate remedial actions. Buyer will fully indemnify TI and its representatives against any damages arising out of the use of any TI components in safety-critical applications.

In some cases, TI components may be promoted specifically to facilitate safety-related applications. With such components, TI's goal is to help enable customers to design and create their own end-product solutions that meet applicable functional safety standards and requirements. Nonetheless, such components are subject to these terms.

No TI components are authorized for use in FDA Class III (or similar life-critical medical equipment) unless authorized officers of the parties have executed a special agreement specifically governing such use.

Only those TI components which TI has specifically designated as military grade or "enhanced plastic" are designed and intended for use in military/aerospace applications or environments. Buyer acknowledges and agrees that any military or aerospace use of TI components which have **not** been so designated is solely at the Buyer's risk, and that Buyer is solely responsible for compliance with all legal and regulatory requirements in connection with such use.

TI has specifically designated certain components as meeting ISO/TS16949 requirements, mainly for automotive use. In any case of use of non-designated products, TI will not be responsible for any failure to meet ISO/TS16949.

### Products

|                              |  |
|------------------------------|--|
| Audio                        | <a href="http://www.ti.com/audio">www.ti.com/audio</a>                               |
| Amplifiers                   | <a href="http://amplifier.ti.com">amplifier.ti.com</a>                               |
| Data Converters              | <a href="http://dataconverter.ti.com">dataconverter.ti.com</a>                       |
| DLP® Products                | <a href="http://www.dlp.com">www.dlp.com</a>   |
| DSP                          | <a href="http://dsp.ti.com">dsp.ti.com</a>   |
| Clocks and Timers            | <a href="http://www.ti.com/clocks">www.ti.com/clocks</a>                             |
| Interface                    | <a href="http://interface.ti.com">interface.ti.com</a>                               |
| Logic                        | <a href="http://logic.ti.com">logic.ti.com</a>                                       |
| Power Mgmt                   | <a href="http://power.ti.com">power.ti.com</a>                                       |
| Microcontrollers             | <a href="http://microcontroller.ti.com">microcontroller.ti.com</a>                   |
| RFID                         | <a href="http://www.ti-rfid.com">www.ti-rfid.com</a>                                 |
| OMAP Applications Processors | <a href="http://www.ti.com/omap">www.ti.com/omap</a>                                 |
| Wireless Connectivity        | <a href="http://www.ti.com/wirelessconnectivity">www.ti.com/wirelessconnectivity</a> |

### Applications

|                               |  |
|-------------------------------|--|
| Automotive and Transportation | <a href="http://www.ti.com/automotive">www.ti.com/automotive</a>                         |
| Communications and Telecom    | <a href="http://www.ti.com/communications">www.ti.com/communications</a>                 |
| Computers and Peripherals     | <a href="http://www.ti.com/computers">www.ti.com/computers</a>                           |
| Consumer Electronics          | <a href="http://www.ti.com/consumer-apps">www.ti.com/consumer-apps</a>                   |
| Energy and Lighting           | <a href="http://www.ti.com/energy">www.ti.com/energy</a>                                 |
| Industrial                    | <a href="http://www.ti.com/industrial">www.ti.com/industrial</a>                         |
| Medical                       | <a href="http://www.ti.com/medical">www.ti.com/medical</a>                               |
| Security                      | <a href="http://www.ti.com/security">www.ti.com/security</a>                             |
| Space, Avionics and Defense   | <a href="http://www.ti.com/space-avionics-defense">www.ti.com/space-avionics-defense</a> |
| Video and Imaging             | <a href="http://www.ti.com/video">www.ti.com/video</a>                                   |

### TI E2E Community

[e2e.ti.com](http://e2e.ti.com)

## Looking for pricing, stock, or lifecycle information?

Click below to explore more details on WIN SOURCE:

 [View DS125BR820NJYT on WIN SOURCE](#)

 [Texas Instruments](#) Information

## Optimize Your Supply Chain with WIN SOURCE Solutions

-  Global Sourcing Solution
-  Obsolete Management
-  Cost Control Management
-  Shortage Management
-  Alternative Solution
-  Excess Inventory Management