



THE DATASHEET OF
DF7-6RS/P-3.96



3.96 mm Pitch Miniature Connectors for Internal Power Supplies (UL,C-UL and TÜV Listed)

DF7 Series

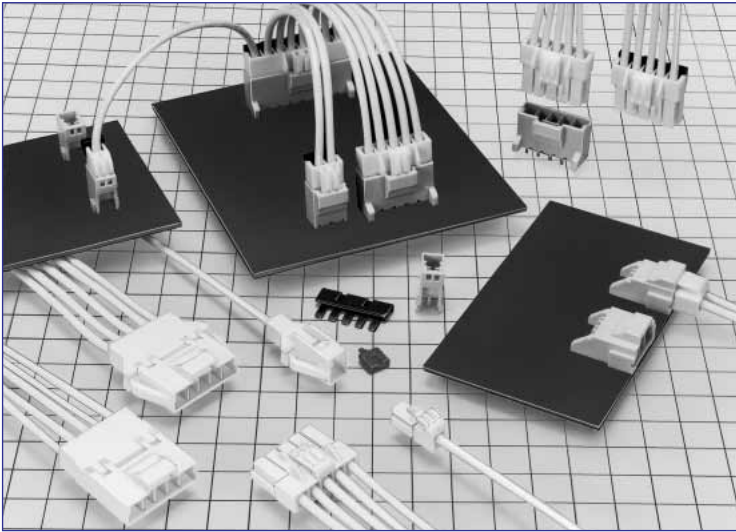

Complete Locking Function

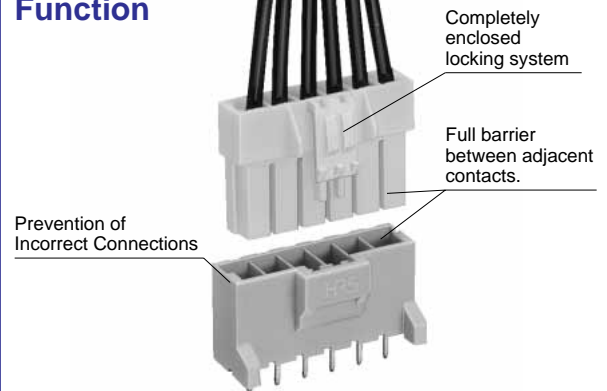

Features

1. Complete Locking Function

Reliable interior lock protects mated connectors from accidental disconnection.

2. Increased Contact Retention of Crimped Contacts and Prevention of Incomplete Insertion

Separate contact retainer increases the contact retention, assures and visually confirms the complete contact insertion.

3. Molded-in Contact Retention Tabs

Handling of terminated contacts during the assembly and termination is easier and avoids entangling of wires, since there are no protruding metal tabs.

4. Incorrect Insertion Prevention

Connectors are polarized to assure correct mating with corresponding parts.

5. Solder Crack Prevention

Glass reinforced resin is used in the pin header bodies to prevent solder cracks caused by the heat shrinkage.

6. Prevention of Incorrect Board Placement

Built-in locating posts assure correct connector placement and orientation on the board.(2-12 pos.)

7. Supports Sealing after Installation.

Sealing compound can be applied to the board installed connector for distance of 6 mm max. from the mounting surface (9 mm max. for single position).

8. Cost Effective Tooling

The same crimping tools are used to terminate socket and pin contacts.

9. Prevention of Short Circuits between Adjacent Contacts

Each contact is completely surrounded by the insulator housing, electrically isolating it from adjacent contacts.

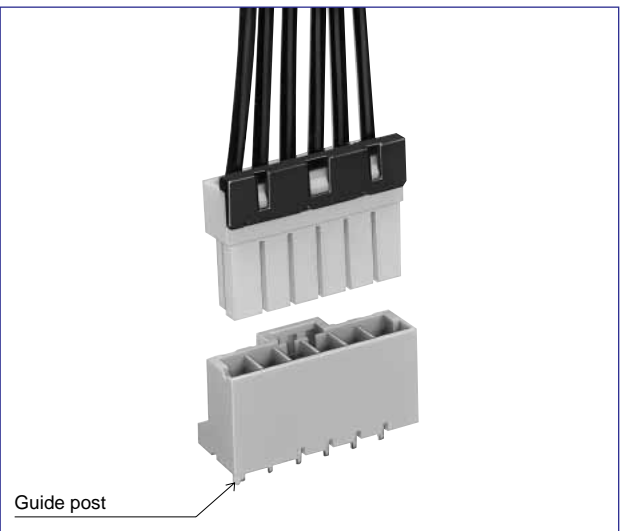

Board Eyelet mounting

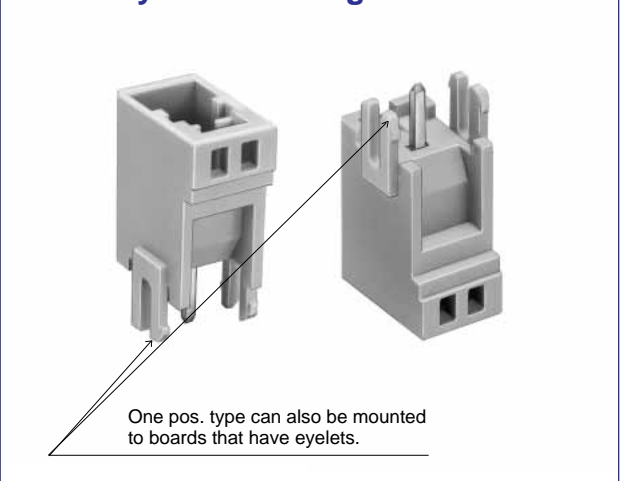

Continued.

10. 10 A maximum Current

Connector can carry current of 10 A per contact with #16 AWG conductor. Refer to page 3 for current ratings for multi-position connectors using other conductor sizes.

11. Color Variations







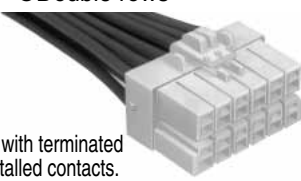

1 pos. is available in a standard 3 colors: natural, blue, and red.

12. Supports Eyelets

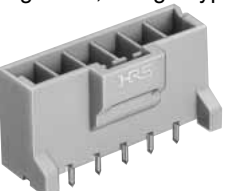
1 pos. can be mounted to boards which have eyelets attached.

Applications

Office equipment, power supplies for industrial, medical and instrumentation applications, variety of consumer electronic and electrical applications.

Crimp Sockets		Retainer (optional, order separately)
<p>● Single row</p>  <p>Shown with terminated and installed contacts. Refer to page 8 for details.</p>	<p>● Double rows</p>  <p>Shown with terminated and installed contacts. Refer to page 11 for details.</p>	
Header		 <p>Refer to page 10 for details.</p>
<p>● Single row, straight type</p>  <p>Refer to page 4 for details.</p>	<p>● Double rows, straight type</p>  <p>Refer to page 10 for details.</p>	
<p>● Single row, right angle type</p>  <p>Refer to page 5 for details.</p>	<p>● Double row, right angle type</p>  <p>Refer to page 10 for details.</p>	
In-line plug		
<p>● Panel lock type</p>  <p>Shown with terminated and installed contacts. Refer to page 6 for details.</p>		
 <p>Shown with terminated and installed contacts. Refer to page 7 for details.</p>		

Ordering information

● Socket, Header

DF7 - * S - 3.96 C

① ② ③ ④ ⑤

● Contacts

DF7 - ** SCF

① ⑥ ⑦

① Series name: DF7, DF7A	⑥ Applicable Conductor 1618: AWG 16 to AWG 18 2022: AWG 20 to AWG 22 2426: AWG 24 to AWG 26
② Number of contacts: 1 to 12	
③ Connector type S: Socket DS: Double-row socket P: Header DP: Double-row Header EP: In-line plug RS/P: Retainer	⑦ Packaging SCF: Socket contacts / Reel SC: Socket contacts / Bag PCF: Plug contacts / Reel PC: Plug contacts / Bag
④ Contact pitch: 3.96mm(7.92 mm)	
⑤ Type of housing: header C: Crimp housing DSA: Straight header DS: Right-angle header Blank: Retainer	

Product Specifications

Ratings	Current rating	Row	No. of contacts	AWG16	AWG18	AWG20	AWG22			
		1	1~10	10A	7A	5A	4A	Operating temperature range	-35°C to 85°C (Note 1)	
		2	4	10A	9A	7A	6A	Operating humidity range	20% to 80%	
			6	9A	8A	6A	5A			
			8	9A	8A	6A	5A	Storage temperature range	-10°C to 60°C (Note 2)	
			10	8A	7A	5A	4A			
	12	8A	7A	5A	4A	Storage humidity range	40% to 70% (Note 2)			
	Voltage rating	Specification			AC 630V			UL/C-UL/TÜV	File No. and Recognition No	
		UL/C-UL			AC 600V			UL	:E52653	
		TÜV			AC 600V(7.92mm pitch)			C-UL	:E52653	
AC 300V (3.96mm pitch)					TÜV	:R9750437				

Item	Specification	Condition
1. Contact resistance	Contact resistance(Initial value)	10 m ohms max. 20mV max., 1mA
2. Insulator resistance	1000 M ohms min.	500 V DC
3. Withstanding voltage	No flashover or Insulator breakdown	1500 V AC for 1 minute
4. Insertion-Extraction force (per contact)	0.3N min., 4.5N max.	Measured with a steel pin of 0.64 x 1.2 ± 0.002 mm
5. Durability (mating/unmating)	30 cycles	Contact resistance of 20 m ohms max.
6. Vibration	No momentary disconnections of 1 μs min.	Frequency 10 to 55 Hz, single amplitude of 0.75 mm, 3 axis, 2 hours
7. Shock	No electrical discontinuity of 1 μs. min.	Acceleration of 490 m/s ² , 11 ms duration, sine half-wave waveform, 3 cycles in each of the 3 axis.
8. Humidity	Contact resistance 20 m ohms max.	Temperature 40°C ± 2°C, 90% to 95% RH, 96 hours
9. Temperature cycle	Contact resistance of 20 m ohms max.	(-55°C: 30 minutes → 5 to 35°C: 5 minutes → 85°C: 30 minutes → 5 to 35°C: 5 minutes) for 5 cycles
10. Resistance to soldering heat	No deformation of the insulator parts affecting performance	Flow solder temperature 250°C, 10 seconds Manual soldering: Soldering iron temperature 300°C, 3 seconds

Note 1: Includes temperature rise caused by the current flow.

Note 2: The term "storage" refers to products stored for long period of time prior to mounting and use. Operating Temperature Range and Humidity range covers non- conducting condition of installed connectors in storage, shipment or during transportation.

Materials

Product	Part	Material	Finish	Remarks
Sockets	Insulator	Polyamide	Color: White	UL94V-0
Headers	Insulator	Polyamide (Glass reinforced)	Color: Beige (Single row) Color: Grey (Double row)	UL94V-0
	Contact	High conductivity copper alloy	Tin plating (Note)	—
In-line plug	Insulator	Polyamide	Color: White	UL94V-0
Retainer	Insulator	Polyamide	Color: Black	UL94V-0
Crimp contacts	Contacts	High conductivity copper alloy	Tin plating (Note)	—

Note: Hirose Electric's plating incorporates anti-whisking compounds.

■ Straight header

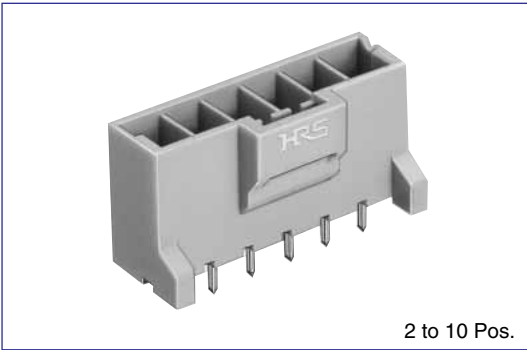
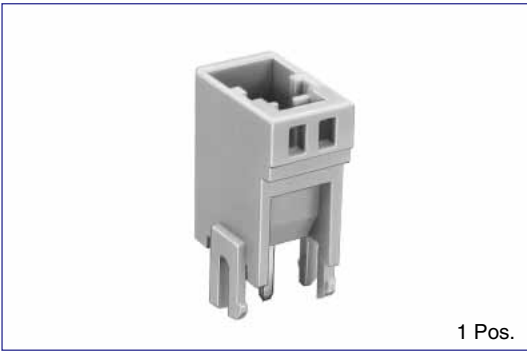

Part Number	CL No.	Number of contacts	A	B
DF7- 1P-3.96DSA	CL680-0133-1	1	—	—
DF7- 2P-3.96DSA	CL680-0036-5	2	10.40	3.96
DF7- 3P-3.96DSA	CL680-0037-8	3	14.36	7.92
DF7- 4P-3.96DSA	CL680-0038-0	4	18.32	11.88
DF7- 5P-3.96DSA	CL680-0039-3	5	22.28	15.84
DF7- 6P-3.96DSA	CL680-0040-2	6	26.24	19.80
DF7- 7P-3.96DSA	CL680-0041-5	7	30.20	23.76
DF7- 8P-3.96DSA	CL680-0042-8	8	34.16	27.72
DF7- 9P-3.96DSA	CL680-0043-0	9	38.12	31.68
DF7-10P-3.96DSA	CL680-0044-3	10	42.08	35.64
DF7- 2P-7.92DSA	CL680-0108-4	2	14.36	7.92
DF7- 3P-7.92DSA	CL680-0109-7	3	22.28	15.84
DF7- 4P-7.92DSA	CL680-0110-6	4	30.20	23.76
DF7- 5P-7.92DSA	CL680-0111-9	5	38.12	31.68

Note 1) Bag packaging (100 pieces/bag). Order by number of bags.

Note 2) The 2 pos. type does not have walls on both sides.

Note 3) DF7-2P-7.92DSA plug has #2 contact positions of DF7-3P-3.96DSA without contacts inserted and the number of pos. indication is 2.
 (Mating receptacle: DF7#-3S-3-96C)
 DF7-3P-7.92DSA plug has #2 and #4 contact positions of DF7-5P-3.96DSA without contacts inserted and the number of pos. indication is 3.
 (Mating receptacle: DF7#-5S-3-96C)
 DF7-4P-7.92DSA plug has #2, #4 and #6 contact of DF7-7P-3.96DSA without contacts inserted and the number of pos. indication is 4.
 (Mating receptacle: DF7#-7S-3-96C)
 DF7-5P-7.92DSA plug has #2, #4, #6 and #8 contact positions of DF7-9P-3.96DSA without contacts inserted and the number of pos. indication is 5.
 (Mating receptacle: DF7#-9S-3-96C)

1 Pos.

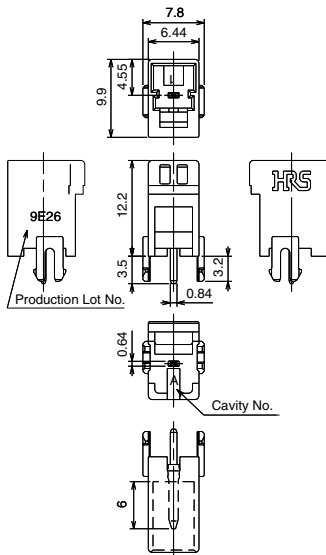

2 to 10 Pos.

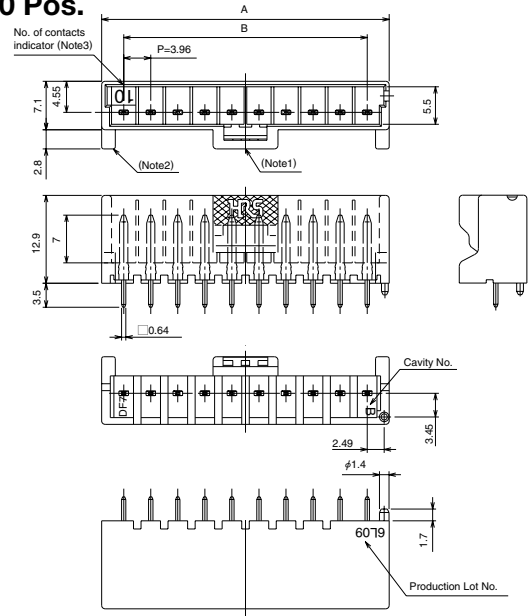

◆ PCB mounting pattern (Board thickness: 1.6 ± 0.1)

1 Pos.

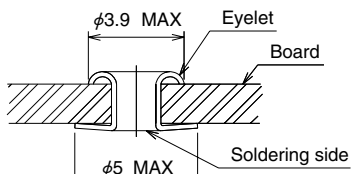

Note 5: One pos. type can also be mounted to boards that have installed eyelets.

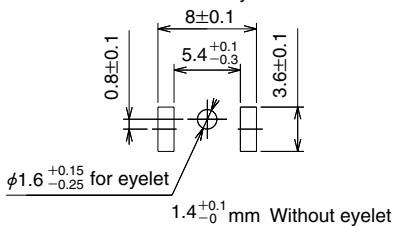

2 to 10 Pos.

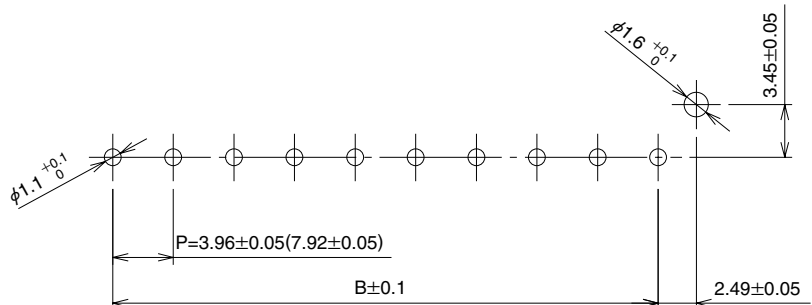

Right angle header

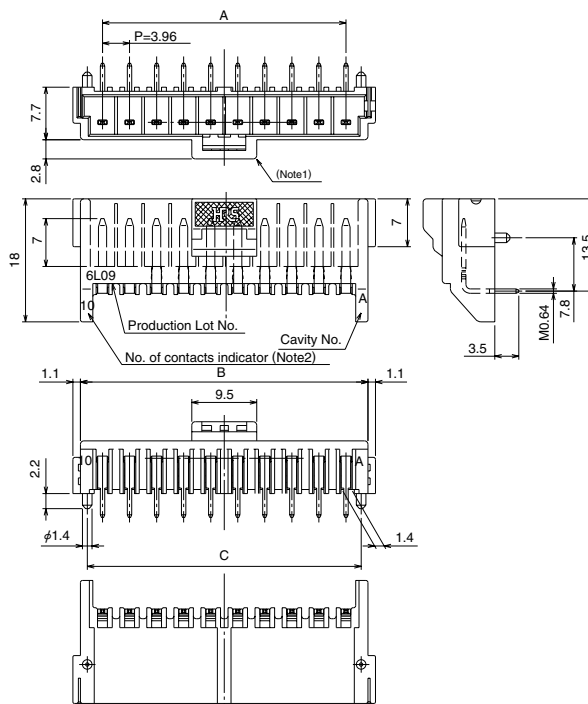

Part Number	CL No.	Number of contacts	A	B	C	Quantity per tray
DF7- 2P-3.96DS(24)	CL680-0081-0-24	2	3.96	10.40	8.40	114
DF7- 3P-3.96DS(24)	CL680-0082-2-24	3	7.92	14.36	12.36	84
DF7- 4P-3.96DS(24)	CL680-0083-5-24	4	11.88	18.32	16.32	66
DF7- 5P-3.96DS(24)	CL680-0084-8-24	5	15.84	22.28	20.28	60
DF7- 6P-3.96DS(24)	CL680-0085-0-24	6	19.80	26.24	24.24	48
DF7- 7P-3.96DS(24)	CL680-0086-3-24	7	23.76	30.20	28.20	42
DF7- 8P-3.96DS(24)	CL680-0087-6-24	8	27.72	34.16	32.16	36
DF7- 9P-3.96DS(24)	CL680-0088-9-24	9	31.68	38.12	36.12	36
DF7-10P-3.96DS(24)	CL680-0089-1-24	10	35.64	42.08	40.08	30
DF7- 2P-7.92DS(24)	CL680-0124-0-24	2	7.92	14.36	12.36	84
DF7- 3P-7.92DS(24)	CL680-0125-3-24	3	15.84	22.28	20.28	60
DF7- 4P-7.92DS(24)	CL680-0126-6-24	4	23.76	30.20	28.20	42
DF7- 5P-7.92DS(24)	CL680-0127-9-24	5	31.68	38.12	36.12	36

Note 1) Tray packaging. Order by number of quantity in the tray.

Note 2) DF7-2P-7.92DS plug has #2 contact positions of DF7-3P-3.96DS without contacts inserted and the number of pos. indication is 2.

(Mating receptacle: DF7#-3S-3-96C)

DF7-3P-7.92DS plug has #2 and #4 contact positions of DF7-5P-3.96DS without contacts inserted and the number of pos. indication is 3.

(Mating receptacle: DF7#-5S-3-96C)

DF7-4P-7.92DS plug has #2, #4 and #6 contact of DF7-7P-3.96DS without contacts inserted and the number of pos. indication is 4.

(Mating receptacle: DF7#-7S-3-96C)

DF7-5P-7.92DS plug has #2, #4, #6 and #8 contact positions of DF7-9P-3.96DS without contacts inserted and the number of pos. indication is 5.

(Mating receptacle: DF7#-9S-3-96C)

PCB mounting pattern (Board thickness: 1.6 ± 0.1)

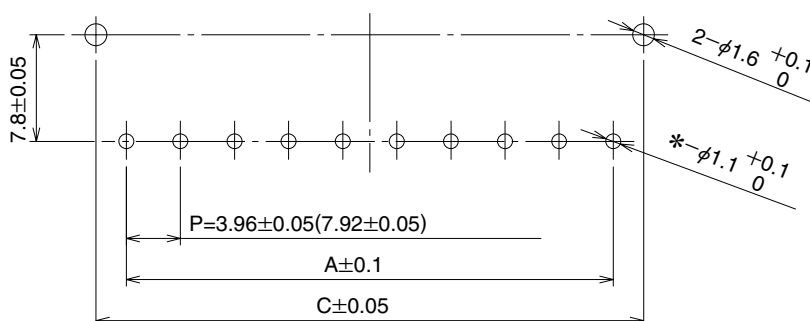

■ In-line plug (Panel lock type)

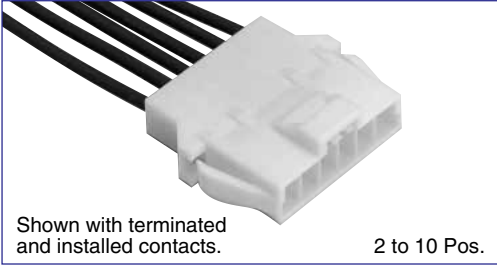
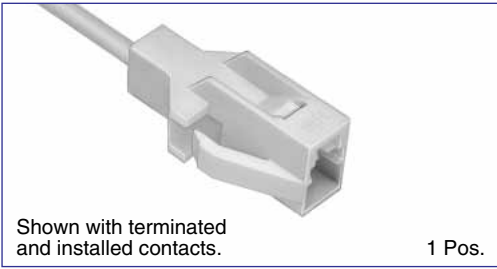

Part Number	CL No.	Number of contacts	A	B	C
DF7- 1EP-3.96C	CL680-0134-4	1	6.44	—	13.96
DF7- 2EP-3.96C	CL680-0018-3	2	10.40	3.96	17.40
DF7- 3EP-3.96C	CL680-0019-6	3	14.36	7.92	21.36
DF7- 4EP-3.96C	CL680-0020-5	4	18.32	11.88	25.32
DF7- 5EP-3.96C	CL680-0021-8	5	22.28	15.84	29.28
DF7- 6EP-3.96C	CL680-0022-0	6	26.24	19.80	33.24
DF7- 7EP-3.96C	CL680-0023-3	7	30.20	23.76	37.20
DF7- 8EP-3.96C	CL680-0024-6	8	34.16	27.72	41.16
DF7- 9EP-3.96C	CL680-0025-9	9	38.12	31.68	45.12
DF7-10EP-3.96C	CL680-0026-1	10	42.08	35.64	49.08

Note1: Bag packaging (100 pieces/bag). Order by number of bags.
 Note2: Refer to page 10 for retainer.

1 Pos.

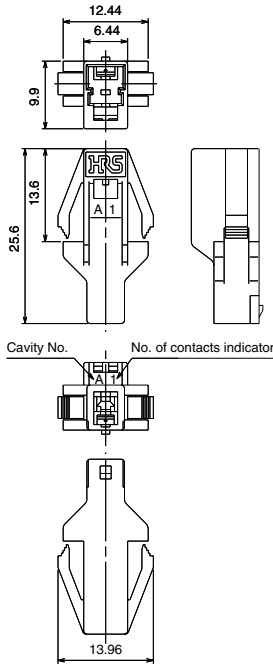

2 to 10 Pos.

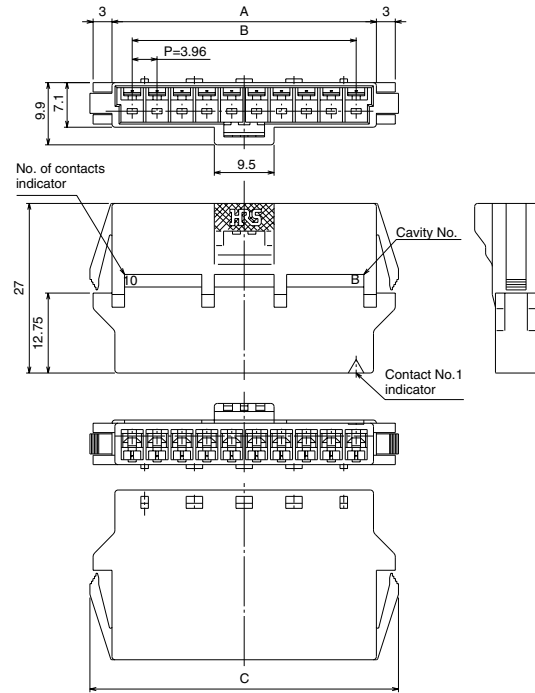

◆ Panel Cutout

1 Pos.

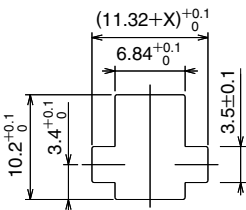

	X	Y
2.0	1.44	0.88
1.6	0.96	0.96
1.2	0.48	1.44
0.8	0	1.92

2 to 10 Pos.

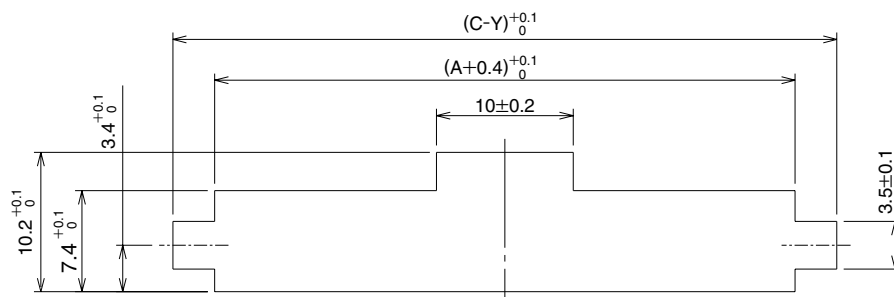

■ In-line Plug

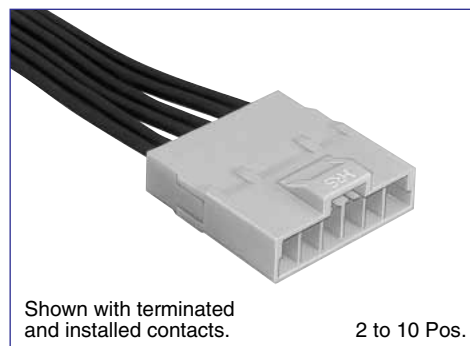
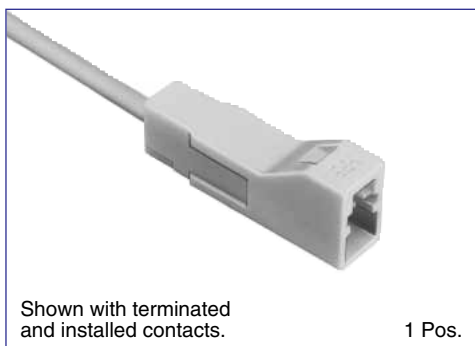

1 Pos.

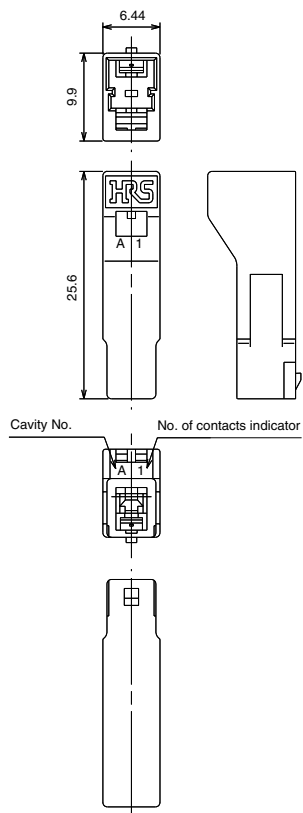

2 to 10 Pos.

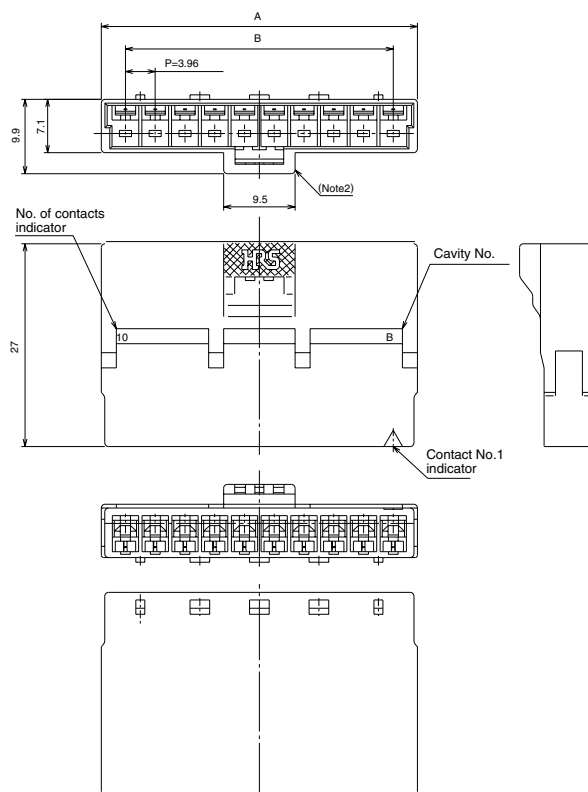

Part Number	CL No.	Number of contacts	A	B
DF7A- 1EP-3.96C	CL680-0135-7	1	6.44	—
DF7A- 2EP-3.96C	CL680-0072-9	2	10.40	3.96
DF7A- 3EP-3.96C	CL680-0073-1	3	14.36	7.92
DF7A- 4EP-3.96C	CL680-0074-4	4	18.32	11.88
DF7A- 5EP-3.96C	CL680-0075-7	5	22.28	15.84
DF7A- 6EP-3.96C	CL680-0076-0	6	26.24	19.80
DF7A- 7EP-3.96C	CL680-0077-2	7	30.20	23.76
DF7A- 8EP-3.96C	CL680-0078-5	8	34.16	27.72
DF7A- 9EP-3.96C	CL680-0079-8	9	38.12	31.68
DF7A-10EP-3.96C	CL680-0080-7	10	42.08	35.64

Note1: Bag packaging (100 pieces/bag). Order by number of bags.

Note2: Refer to page 10 for retainer.

■ Crimp Sockets

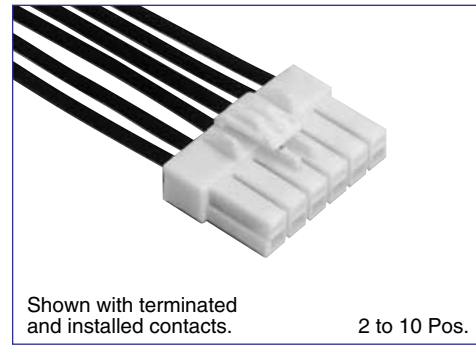
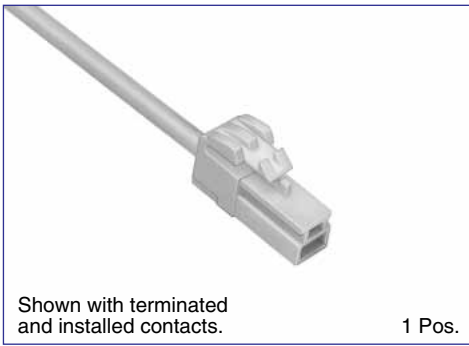

1 Pos.

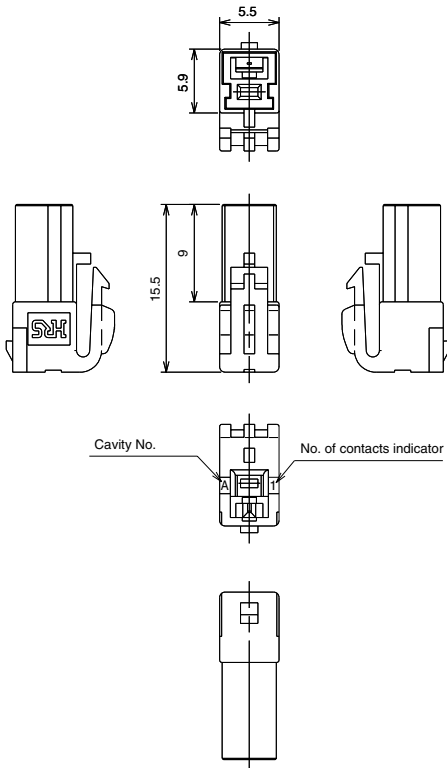

2 to 10 Pos.

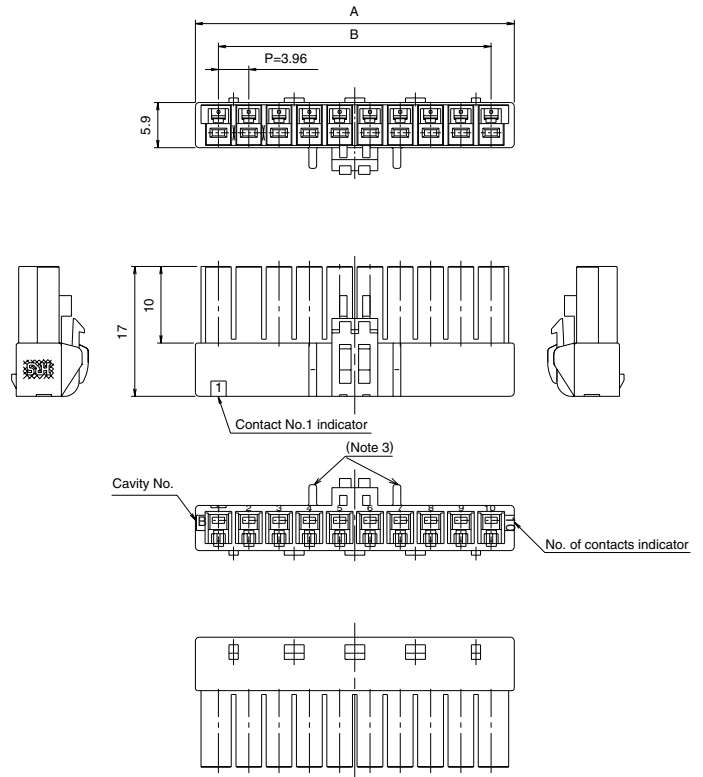

Part Number	CL No.	Number of contacts	A	B
DF7- 1S-3.96C	CL680-0132-9	1	5.50	—
DF7- 2S-3.96C	CL680-0009-2	2	10.00	3.96
DF7- 3S-3.96C	CL680-0010-1	3	13.96	7.92
DF7- 4S-3.96C	CL680-0011-4	4	17.92	11.88
DF7- 5S-3.96C	CL680-0012-7	5	21.88	15.84
DF7- 6S-3.96C	CL680-0013-0	6	25.84	19.80
DF7- 7S-3.96C	CL680-0014-2	7	29.80	23.76
DF7- 8S-3.96C	CL680-0015-5	8	33.76	27.72
DF7- 9S-3.96C	CL680-0016-8	9	37.72	31.68
DF7-10S-3.96C	CL680-0017-0	10	41.68	35.64

Note1: Bag packaging (100 pieces/bag). Order by number of bags.
 Note2: Refer to page 10 for retainer.

■ Retainer



1 Pos.

2 to 10 Pos.

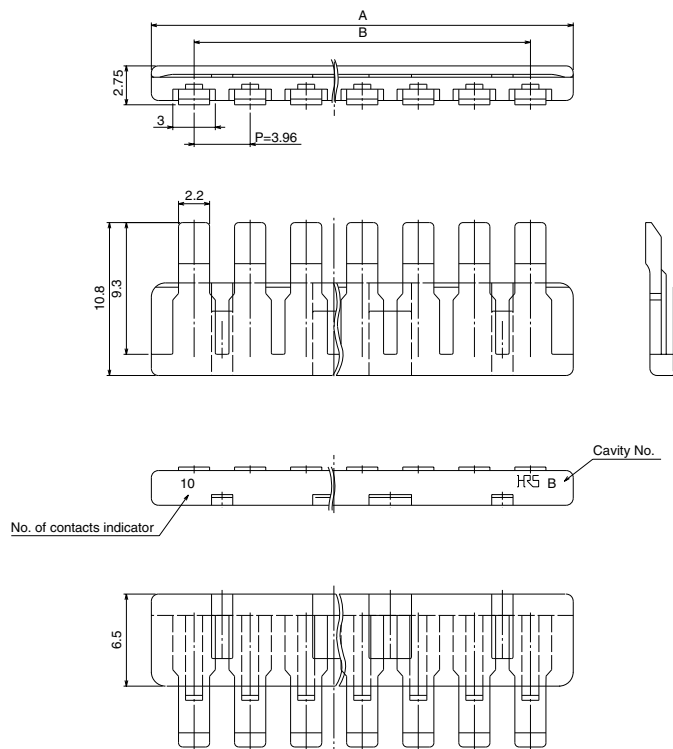
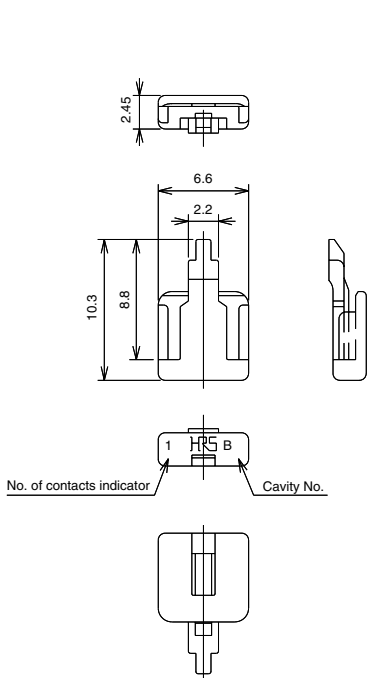

Part Number	CL No.	Number of contacts	A	B
DF7- 1RS/P-3.96	CL680-0136-0	1	—	—
DF7- 2RS/P-3.96	CL680-0027-4	2	10.00	3.96
DF7- 3RS/P-3.96	CL680-0028-7	3	13.96	7.92
DF7- 4RS/P-3.96	CL680-0029-0	4	17.92	11.88
DF7- 5RS/P-3.96	CL680-0030-9	5	21.88	15.84
DF7- 6RS/P-3.96	CL680-0031-1	6	25.84	19.80
DF7- 7RS/P-3.96	CL680-0032-4	7	29.80	23.76
DF7- 8RS/P-3.96	CL680-0033-7	8	33.76	27.72
DF7- 9RS/P-3.96	CL680-0034-0	9	37.72	31.68
DF7-10RS/P-3.96	CL680-0035-2	10	41.68	35.64

Note1: Bag packaging (100 pieces/bag). Order by number of bags.
 Note2: Retainer is common to sockets, in-line plug.

Double-row Straight Header

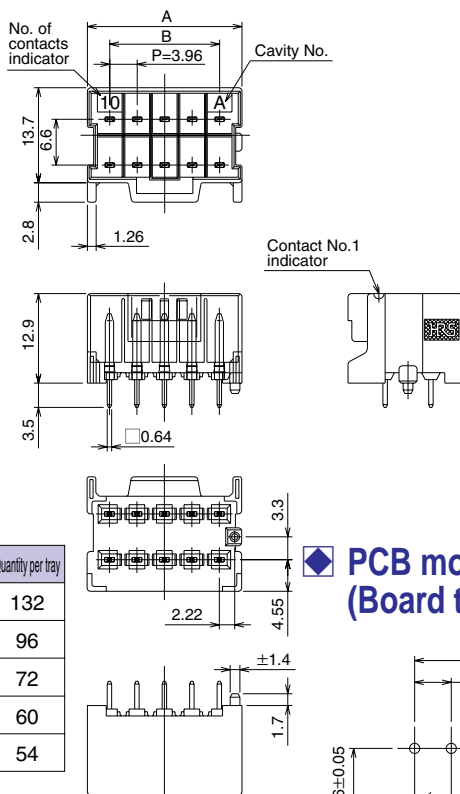
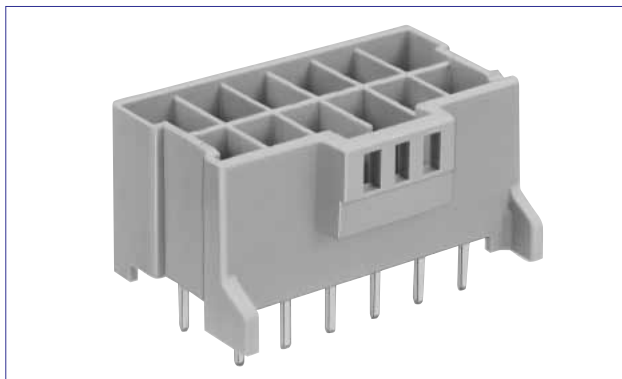

Part Number	CL No.	Number of contacts	A	B	Quantity per tray
DF7- 4DP-3.96DSA(24)	CL680-0145-0-24	4	10.40	3.96	132
DF7- 6DP-3.96DSA(24)	CL680-0146-3-24	6	14.36	7.92	96
DF7- 8DP-3.96DSA(24)	CL680-0147-6-24	8	18.32	11.88	72
DF7-10DP-3.96DSA(24)	CL680-0148-9-24	10	22.28	15.84	60
DF7-12DP-3.96DSA(24)	CL680-0149-1-24	12	26.24	19.80	54

Note: Tray packaging. Order by number of trays quantity.

PCB mounting pattern (Board thickness: 1.6±0.1)

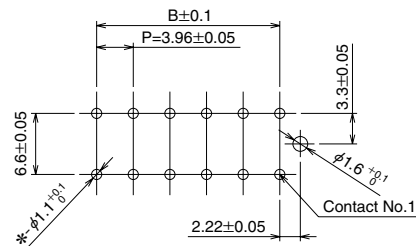

Double-row Right angle Header

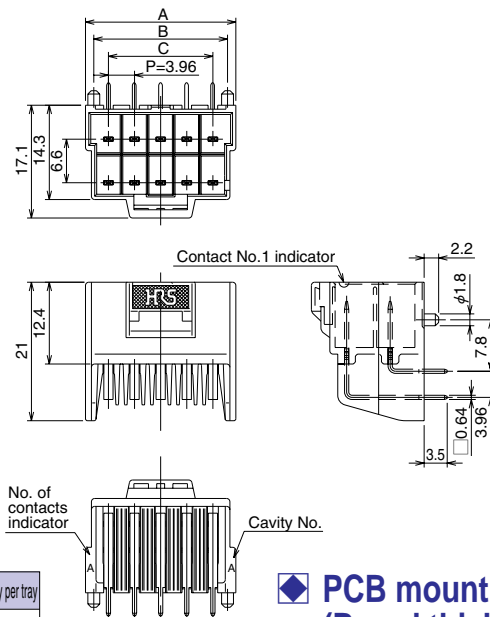
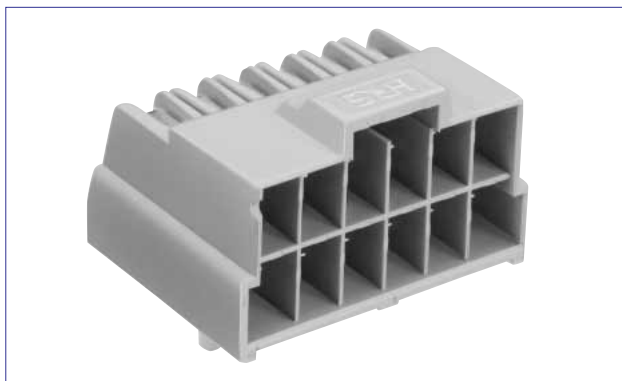

Part Number	CL No.	Number of contacts	A	B	C	Quantity per tray
DF7- 4DP-3.96DS(24)	CL680-0150-0-24	4	10.40	8.40	3.96	88
DF7- 6DP-3.96DS(24)	CL680-0151-3-24	6	14.36	12.36	7.92	64
DF7- 8DP-3.96DS(24)	CL680-0152-6-24	8	18.32	16.32	11.88	48
DF7-10DP-3.96DS(24)	CL680-0153-9-24	10	22.28	20.28	15.84	40
DF7-12DP-3.96DS(24)	CL680-0154-1-24	12	26.24	24.24	19.80	36

Note: Tray packaging. Order by number of trays quantity.

PCB mounting pattern (Board thickness: 1.6±0.1)

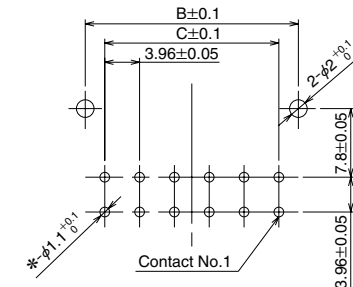

Double-row Socket

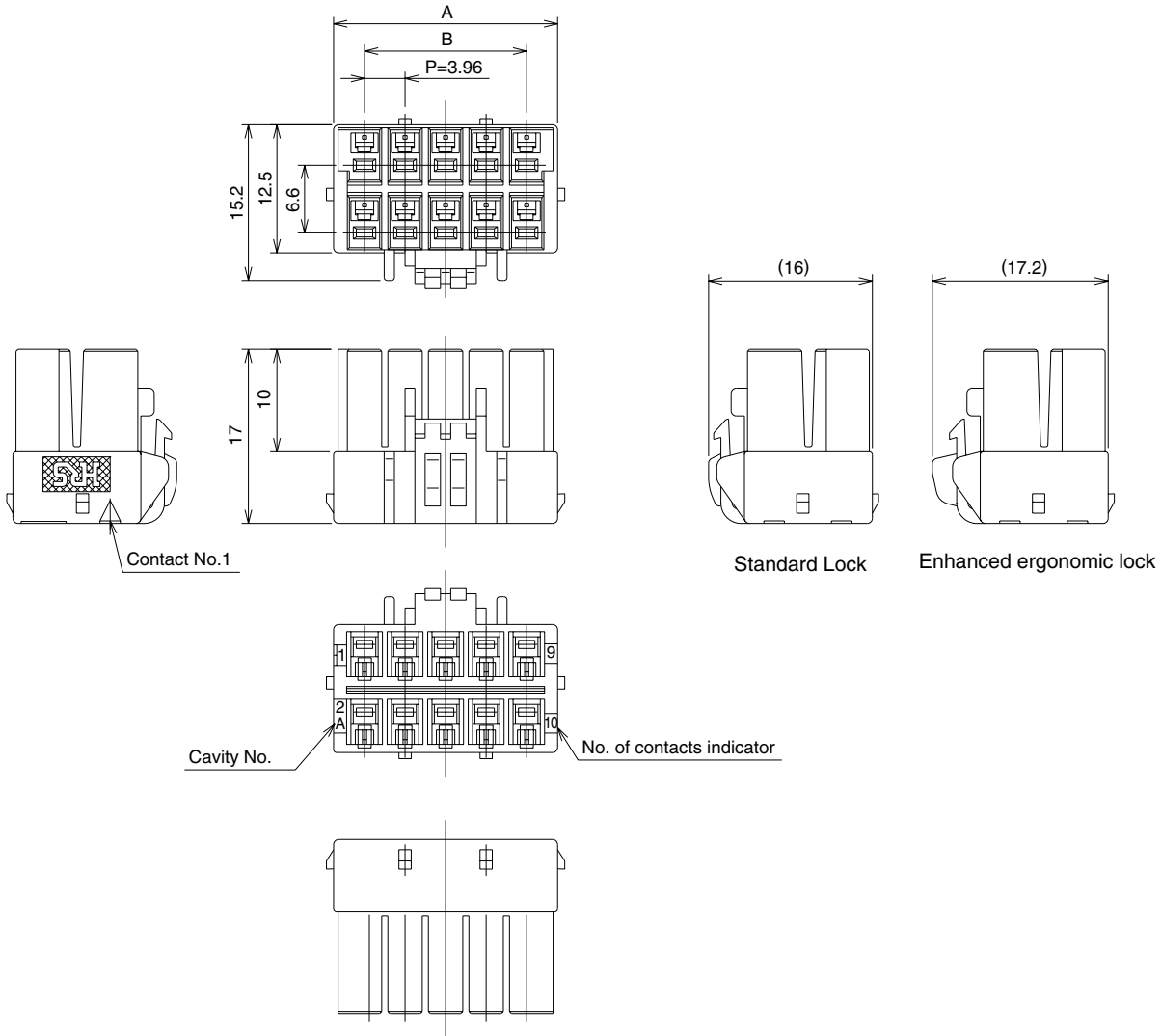
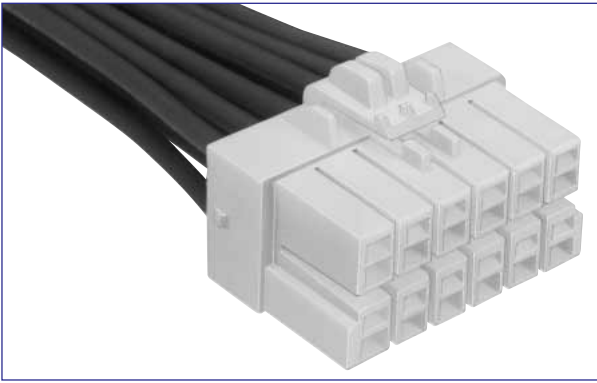

Standard lock

Part Number	CL No.	Number of contacts	A	B
DF7-4DS-3.96C	Reserved For product expansion	4	10.00	3.96
DF7-6DS-3.96C		6	13.96	7.92
DF7-8DS-3.96C		8	17.92	11.88
DF7-10DS-3.96C		10	21.88	15.84
DF7-12DS-3.96C		12	25.84	19.80

Enhanced ergonomic lock

Part Number	CL No.	Number of contacts	A	B
DF7A-4DS-3.96C	CL680-0160-4	4	10.00	3.96
DF7A-6DS-3.96C	CL680-0161-7	6	13.96	7.92
DF7A-8DS-3.96C	CL680-0162-0	8	17.92	11.88
DF7A-10DS-3.96C	CL680-0163-2	10	21.88	15.84
DF7A-12DS-3.96C	CL680-0164-5	12	25.84	19.80

Note: Bag packaging (100 pieces/bag). Order by number of bags.

■ Crimp Contact

● Female Contact

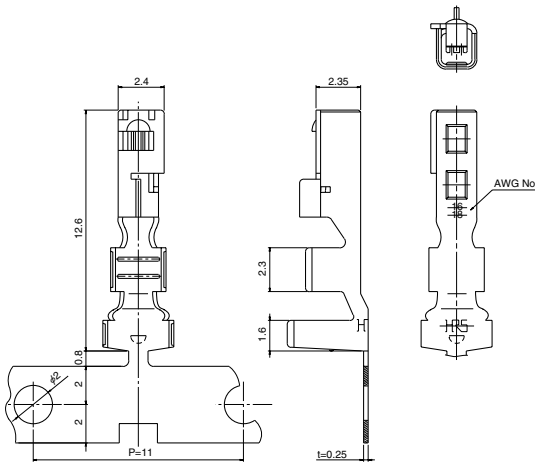

● Male Contact

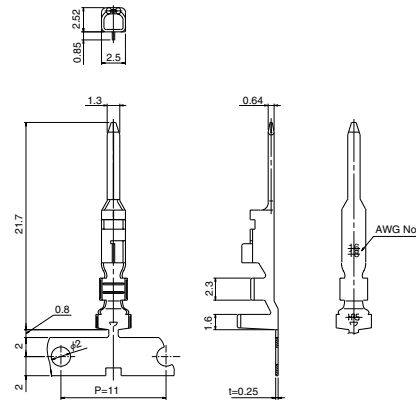

Part Number	CL No.	Packaging	Quantity	Finish
DF7-1618SCF	CL680-0001-0	Reel	3,000	Tin plating
DF7-1618SC	CL680-0002-3	Bag	100	
DF7-2022SCF	CL680-0003-6	Reel	3,000	
DF7-2022SC	CL680-0004-9	Bag	100	
DF7-1618PCF	CL680-0005-1	Reel	3,000	
DF7-1618PC	CL680-0006-4	Bag	100	
DF7-2022PCF	CL680-0007-7	Reel	3,000	
DF7-2022PC	CL680-0008-0	Bag	100	

● Applicable cable (Tin plated annealed copper wire)

Wire size(Stranded wire conductor)	UL style	Jacket diameter	
AWG#16(26/0.254mm)	UL1007	2.1 to 2.5mm	
AWG#18(34/0.18mm)		UL1015	1.6 to 1.9mm
AWG#20(21/0.18mm)			2.9 to 3.2mm
AWG#22(17/0.16mm)			
AWG#16(26/0.254mm)	UL1015		2.9 to 3.2mm
AWG#18(34/0.18mm)		2.4 to 2.7mm	
AWG#20(21/0.18mm)			2.9 to 3.2mm
AWG#22(17/0.16mm)		2.4 to 2.7mm	

Note 1: Applicable wire with tin plated solid soft conductor.

Note 2: When using other than the recommended wire, contact your nearest Hirose representative.

Note 3: Strip length: 3.0 to 3.8mm.

■ Tools

Type	Part Number	CL No.	Applicable Contacts	
Automatic	Press unit	CM-105	CL901-0005-4	
	Applicator	AP105-DF7-1618	CL901-4554-4	DF7-1618SCF/DF7-1618PCF
		AP105-DF7-2022	CL901-4553-1	DF7-2022SCF/DF7-2022PCF
Manual	Crimp tools	HT104/DF7-1618	CL550-0268-0	DF7-1618SC/DF7-1618PC
		HT104/DF7-2022	CL550-0269-3	DF7-2022SC/DF7-2022PC

◆ Mating Dimensions

● Socket to Straight Header Connection

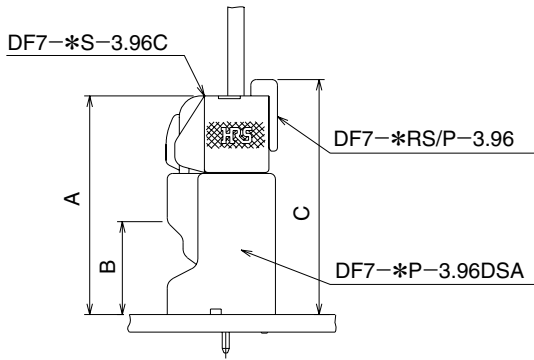

DF7-*S-3.96C		
	1 pos.	2 to 12 pos.
A	18.5	20.0
B	9.0	8.5
C	20.3	21.5

● Socket to Straight Header Connection (Double-row)

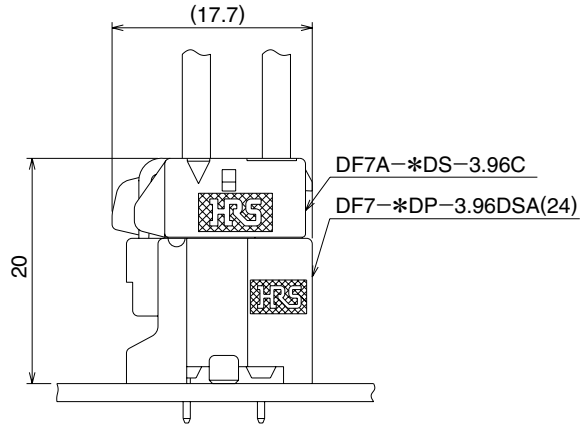
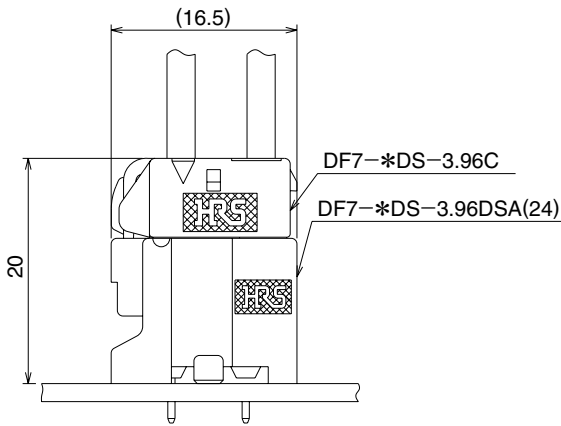

● Socket to Right angle Header Connection

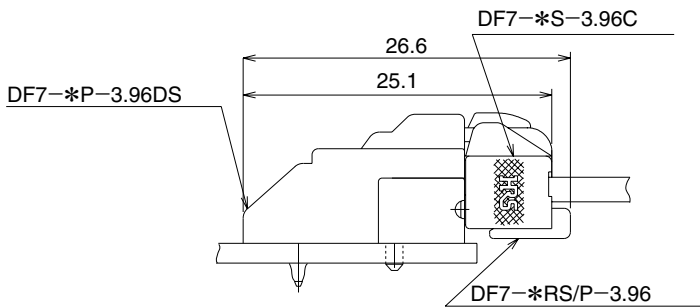

● Socket to Right angle Header Connection (Double-row)

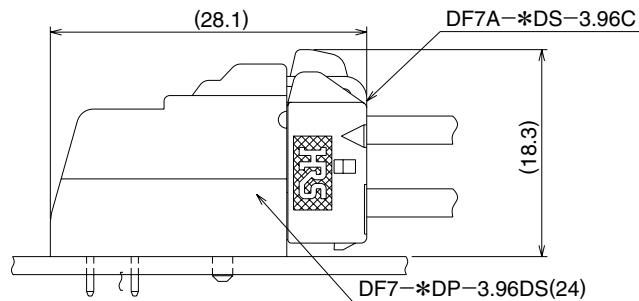
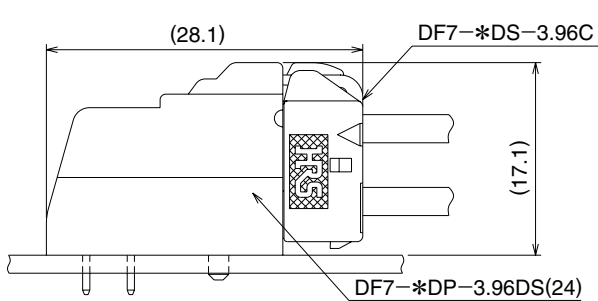

● **Socket to In-line Plug (Panel mount type) Connection**

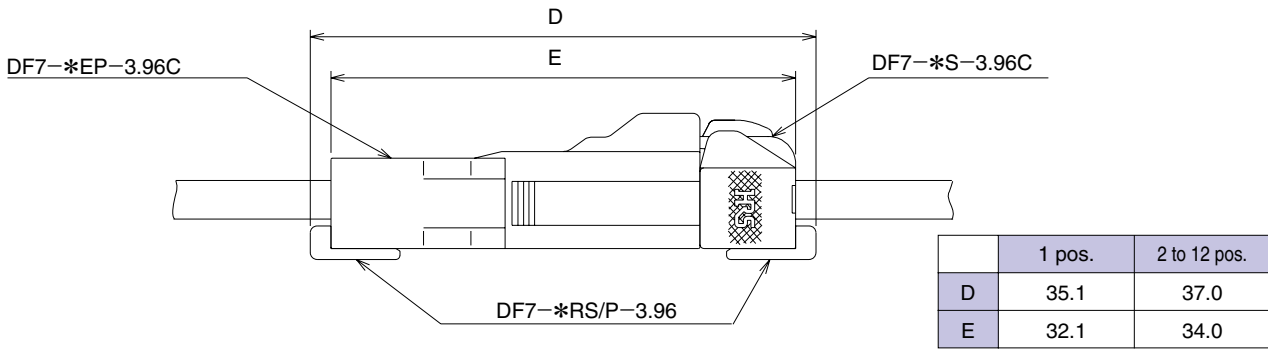

● **Socket to In-line Plug Connection**

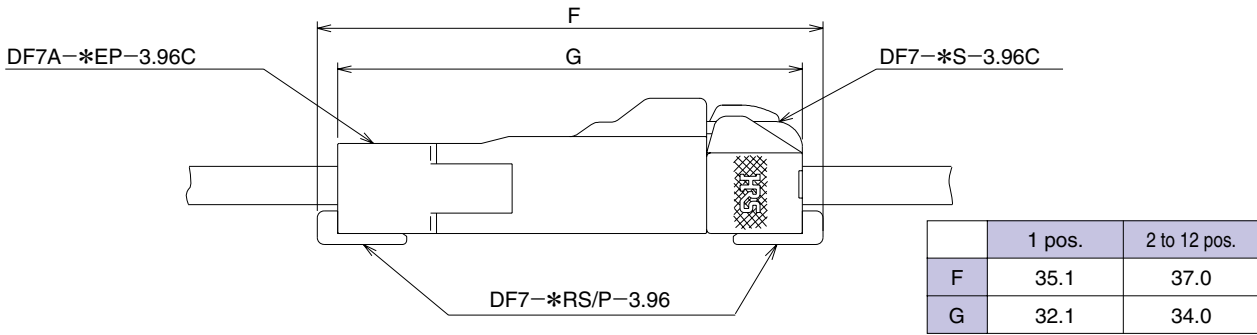

◆ Contact Extraction Procedure

■ Contact extraction tool: Flat-bladed screwdriver, 1.4 mm blade width

■ Use with crimp Contacts: DF7-1618SC(F), DF7-2022SC(F),
DF7-1618PC(F), DF7-2022PC(F)

■ Work Method

Housing Cross-Section

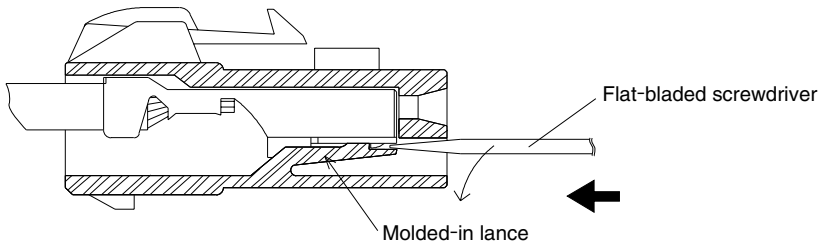

1. Refer to the drawing No. 1. Insert correct size screwdriver in the insulator against the molded-in lance. Deflect the lance as shown.

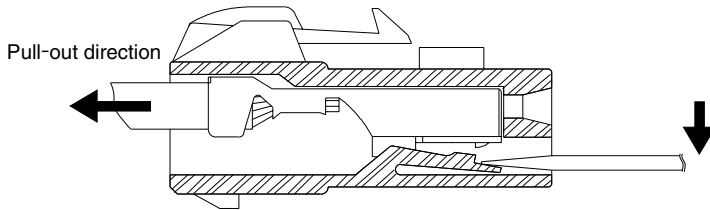

2. Assure that the lance is deflected to release the contact and pull-out wire with the terminated contact.

◆ General Use Precautions







- Make sure that the lock is fully depressed before un-mating the connectors.
- Use correct size of the wires. Do NOT forcefully twist or deform wires, as this may affect the crimped contact connection.
- When the potting process is to be performed, please take into consideration the surface tension of the resin when filling.

Looking for pricing, stock, or lifecycle information?

Click below to explore more details on WIN SOURCE:

-  [View DF7-6RS/P-3.96 on WIN SOURCE](#)
-  [Hirose Electric Co Ltd Information](#)

Optimize Your Supply Chain with WIN SOURCE Solutions

-  Global Sourcing Solution
-  Obsolete Management
-  Cost Control Management
-  Shortage Management
-  Alternative Solution
-  Excess Inventory Management