

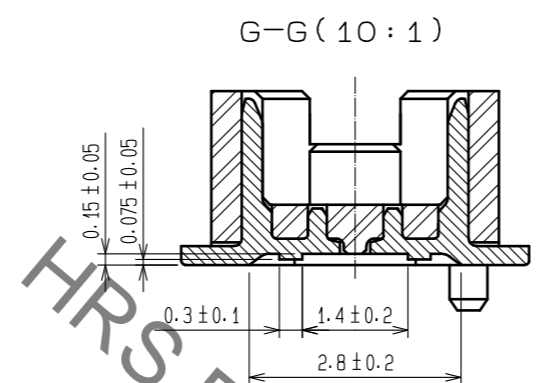

**THE DATASHEET OF
DF12D(3.0)-50DP-0.5V(81)**

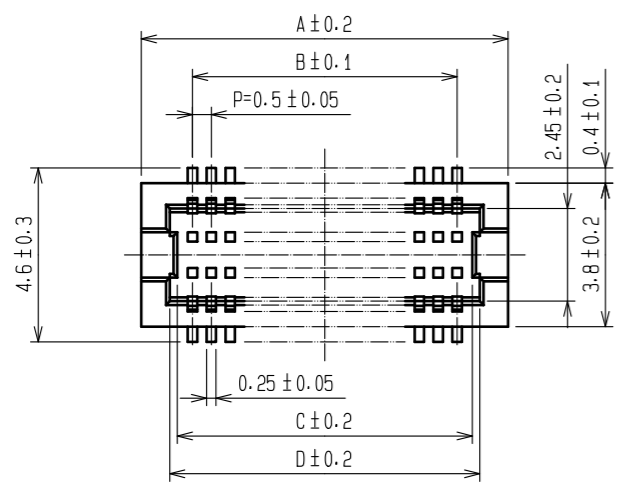

Aug.1.2019 Copyright 2019 HIROSE ELECTRIC CO., LTD. All Rights Reserved.
In case of consideration for using Automotive equipment / device which demand high reliability, kindly contact our sales window correspondents.



CODE No.	CONTACT	A	B	C	D	E	F
CL537-0791-5-81	10	4.7	2.0	2.8	3.2	4.1	2.8
CL537-0920-6-81	14	5.7	3.0	3.8	4.2	5.1	3.8
CL537-0793-0-81	20	7.2	4.5	5.3	5.7	6.6	5.3
CL537-0795-6-81	30	9.7	7.0	7.8	8.2	9.1	7.8
CL537-0802-0-81	32	10.2	7.5	8.3	8.7	9.6	8.3
CL537-0796-9-81	36	11.2	8.5	9.3	9.7	10.6	9.3
CL537-0797-1-81	40	12.2	9.5	10.3	10.7	11.6	10.3
CL537-0799-7-81	50	14.7	12.0	12.8	13.2	14.1	12.8
CL537-0801-7-81	60	17.2	14.5	15.3	15.7	16.6	15.3
CL537-0803-2-81	80	22.2	19.5	20.3	20.7	21.6	20.3

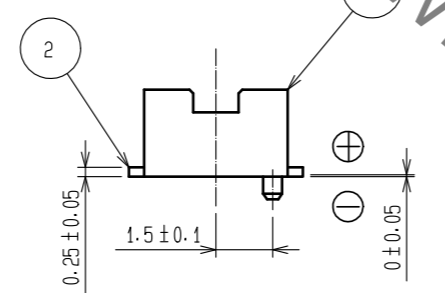
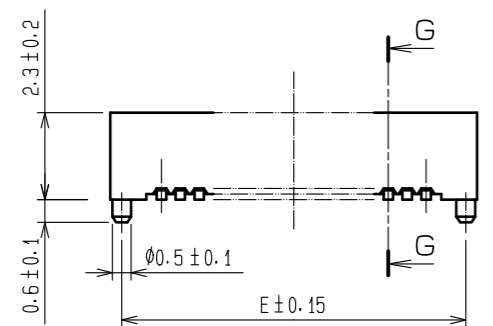

RECOMMEND METAL MASK PATTERN (10:1)

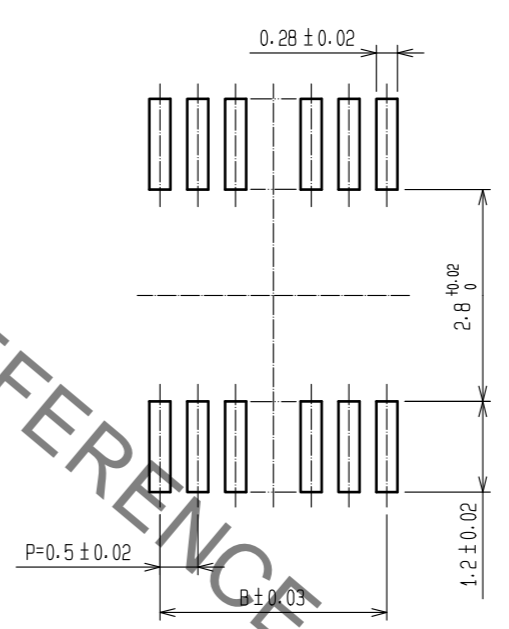

RECOMMENDED THICKNESS OF METAL MASK : 120 #m

RECOMMENDED LAND PATTERN (10:1)

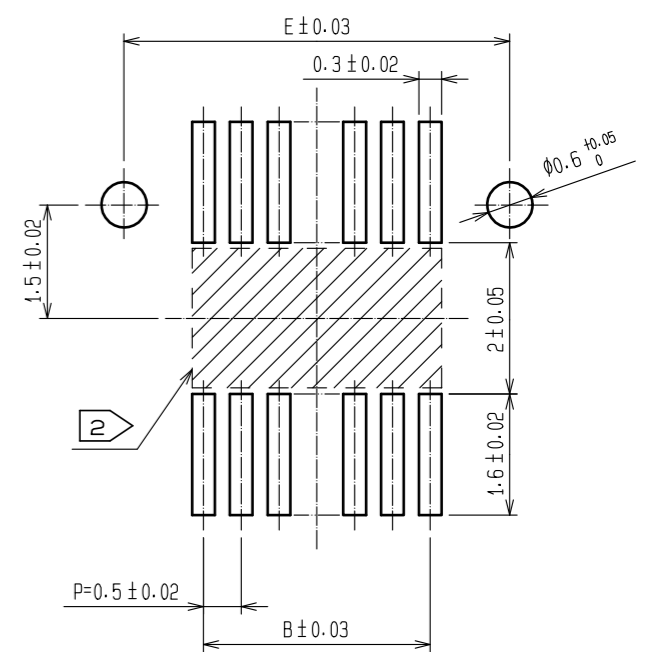

RECOMMENDED THICKNESS OF SOLDER PASTE : 120 #m

NOTES 1 LEAD CO-PLANARITY SHALL BE 0.08 mm MAX.
2 IF THERE IS PATTERN ON PART, THERE IS A POSSIBILITY THAT IT WILL MAKE CONTACT WITH THE LEADS.

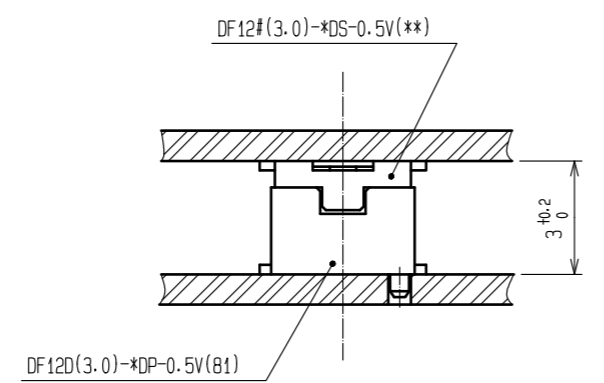

NO.	MATERIAL	FINISH	REMARKS	NO.	MATERIAL	FINISH	REMARKS
2	PHOSPHOR BRONZE		CONTACT AREA:GOLD PLATED 0.2#m min LEAD AREA:GOLD PLATED 0.015#m min OTHERS(UNDER PLATING):NICKEL PLATED 2#m min	6	PS		CLEAR (REINFORCEMENT COLLAR)
				5	PS		BLACK (PLASTIC REEL)
				4	POLYESTER		CLEAR (COVER TAPE)
1	POLYAMIDE		UL94V-0, NATURAL (BEIGE)	3	PS		CLEAR (EMBOSSED CARRIER TAPE)

UNITS	SCALE	COUNT	DESCRIPTION OF REVISIONS	DESIGNED	CHECKED	DATE
mm	5 : 1	△				

HRS HIROSE ELECTRIC CO., LTD.	APPROVED : WR. FUKUCHI	20190409	DRAWING NO.	EDC-163508-81-78
	CHECED : WR. FUKUCHI	20190409	PART NO.	DF12D(3.0)-*DP-0.5V(81)
	DESIGNED : KT. KUSAKA	20190409	CODE NO.	CL537
	DRAWN : RN. IIDA	20190409		

Aug.1.2019 Copyright 2019 HIROSE ELECTRIC CO., LTD. All Rights Reserved.
In case of consideration for using Automotive equipment / device which demand high reliability, kindly contact our sales window correspondents.

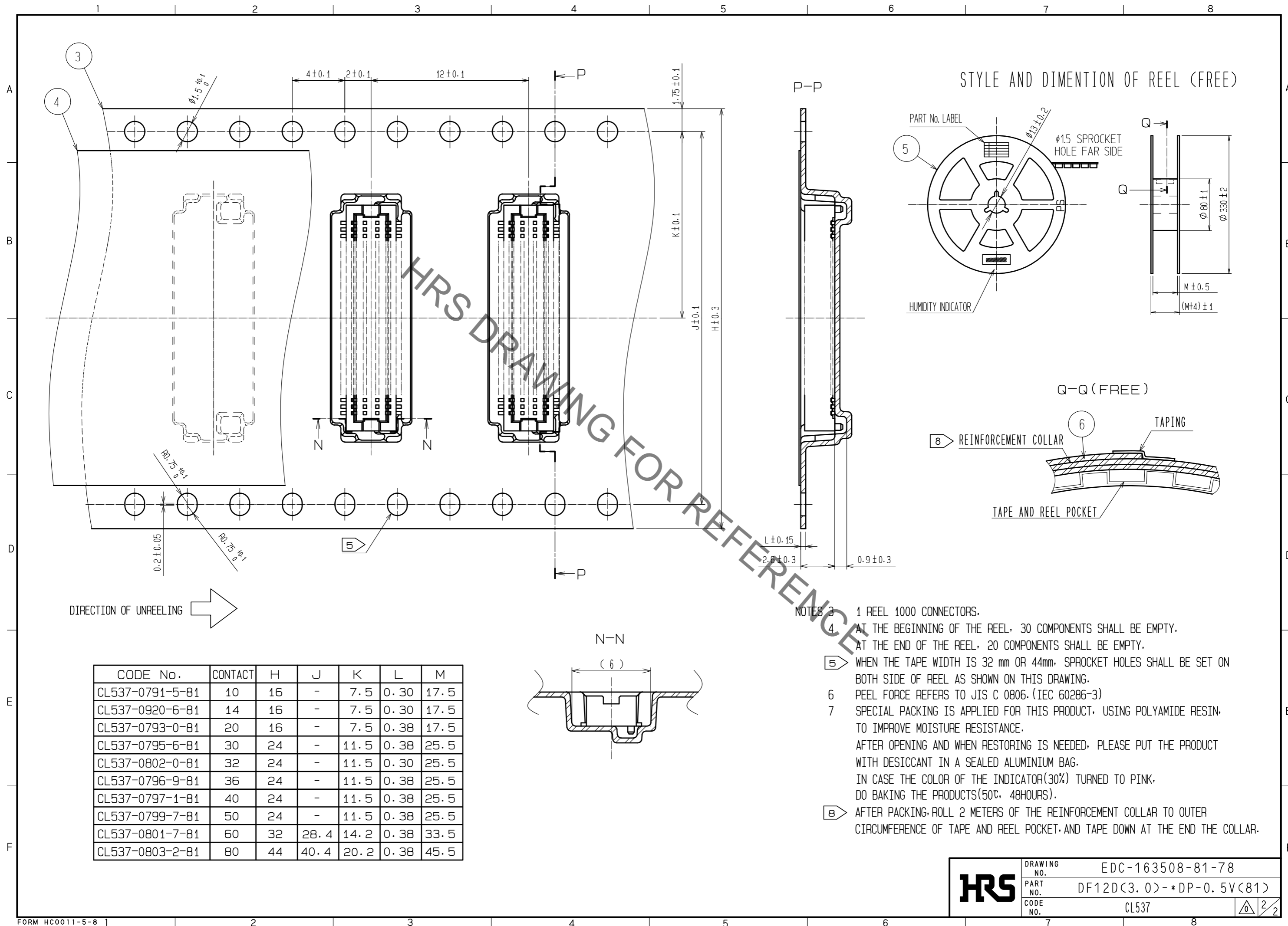

HRS	DRAWING NO.	EDC-163508-81-78
	PART NO.	DF12D(3.0)-*DP-0.5V(81)
	CODE NO.	CL537

Looking for pricing, stock, or lifecycle information?

Click below to explore more details on WIN SOURCE:

- [View DF12D\(3.0\)-50DP-0.5V\(81\) on WIN SOURCE](#)
- [Hirose Electric Co Ltd Information](#)

Optimize Your Supply Chain with WIN SOURCE Solutions

- ✓ Global Sourcing Solution
- ✓ Obsolete Management
- ✓ Cost Control Management
- ✓ Shortage Management
- ✓ Alternative Solution
- ✓ Excess Inventory Management