



# THE DATASHEET OF X-NUCLEO-IDB05A1



## Bluetooth Low Energy expansion board based on the SPBTLE-RF module for STM32 Nucleo

Data brief

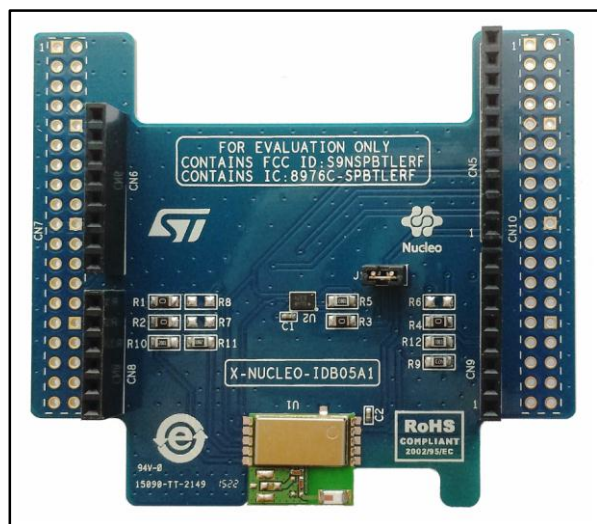

### Description

The X-NUCLEO-IDB05A1 is a Bluetooth Low Energy evaluation board based on the SPBTLE-RF BlueNRG-MS RF module to allow expansion of the STM32 Nucleo boards. The SPBTLE-RF module is FCC (FCC ID: S9NSPBTLERF) and IC certified (IC: 8976C-SPBTLERF).

The X-NUCLEO-IDB05A1 is compatible with the ST Morpho and Arduino UNO R3 connector layout (the user can mount the ST Morpho connectors, if required). The X-NUCLEO-IDB05A1 interfaces with the STM32 microcontroller via the SPI pin, and the user can change the default SPI clock, the SPI chip select and SPI IRQ by changing one resistor on the evaluation board.

### Features

- STM32 expansion board based on the SPBTLE-RF module for STM32 Nucleo
- X-NUCLEO-IDB05A1 contains FCC and IC certified module SPBTLE-RF (FCC ID: S9NSPBTLERF and IC: 8976C-SPBTLERF)
- SPBTLE-RF:
  - Bluetooth Low Energy FCC and IC certified module based on Bluetooth® SMART 4.1 network processor BlueNRG-MS
  - Integrated Balun (BALF-NRG-01D3)
  - Chip antenna
- Compatible with STM32 Nucleo boards
- Equipped with Arduino UNO R3 connector
- Scalable solution, capable of cascading multiple boards for larger systems
- Free comprehensive development firmware library and example for BlueNRG-MS, compatible with STM32Cube firmware
- RoHS compliant

## 1 **Formal notices required by the U.S. Federal Communications Commission ("FCC")**

Any changes or modifications to this equipment not expressly approved by STMicroelectronics may cause harmful interference and void the user's authorization to operate this equipment.

This device complies with Part 15 of the FCC rules. Operation is subject to the following two conditions: (1) this device may not cause harmful interference, and (2) this device must accept any interference received, including any interference that may cause undesired operation.

This device uses, generates and radiates radio frequency energy. The radio frequency energy produced by this device is well below the maximum exposure allowed by the Federal Communications Commission (FCC).

The X-NUCLEO-IDB05A1 contains FCC certified module SPBTLE-RF (FCC ID: S9NSPBTLERF).

## 2 Formal notices required by the Industry Canada ("IC")

English:

This device complies with Industry Canada license-exempt RSS standard(s). Operation is subject to the following two conditions: (1) this device may not cause interference, and (2) this device must accept any interference, including interference that may cause undesired operation of the device.

French:

Le présent appareil est conforme aux CNR d'Industrie Canada applicables aux appareils radio exempts de licence. Exploitation est autorisée aux deux conditions suivantes: (1) l'appareil ne doit pas produire de brouillage, et (2) l'utilisateur de l'appareil doit accepter tout brouillage radioélectrique subi, même si le brouillage est susceptible d'en compromettre le fonctionnement.

The X-NUCLEO-IDB05A1 contains IC certified module SPBTLE-RF (IC: 8976C-SPBTLERF).

### 3 Hardware schematic diagrams

Figure 1: Nucleo connectors

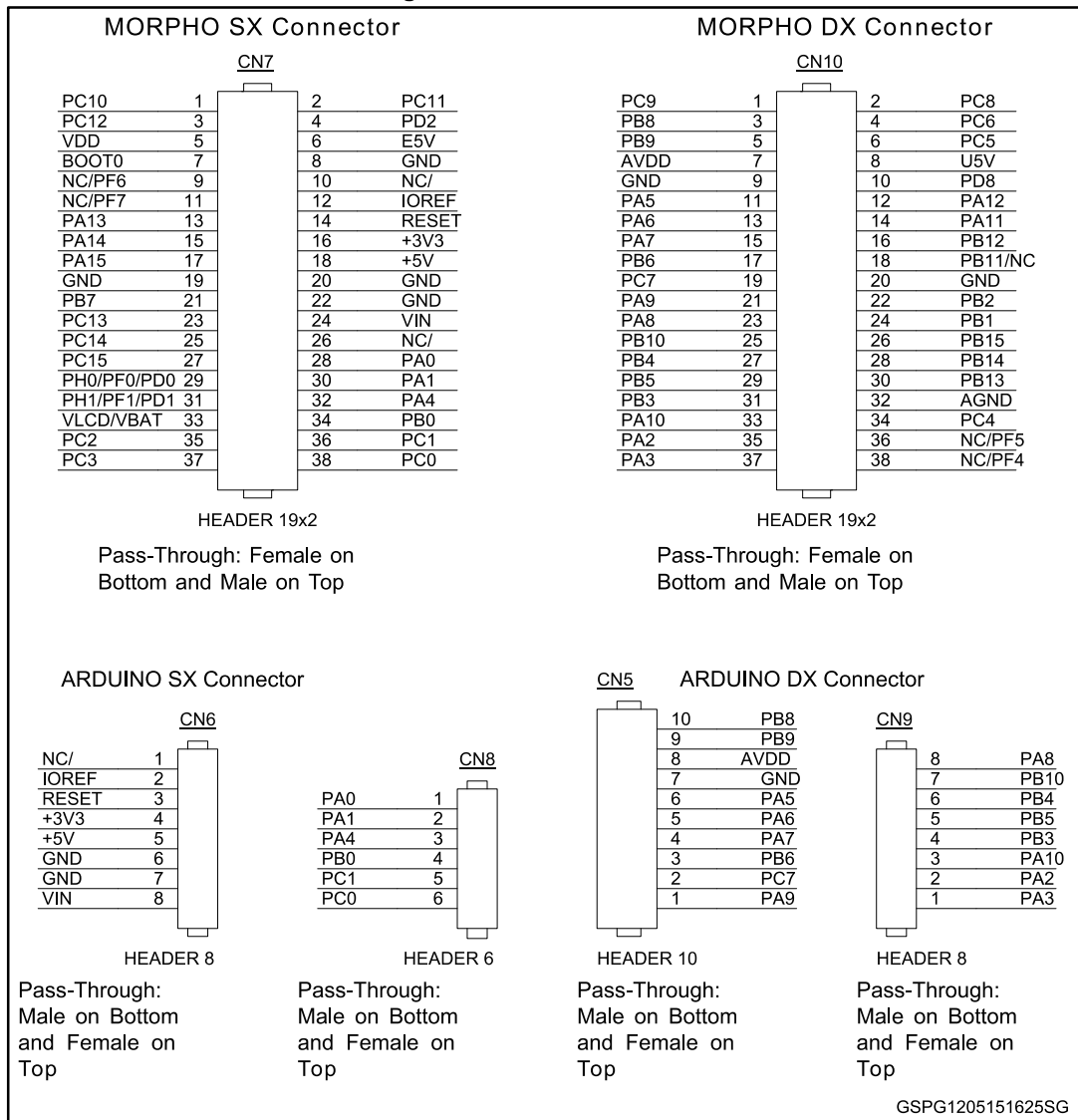

Figure 2: SPBTLE-RF

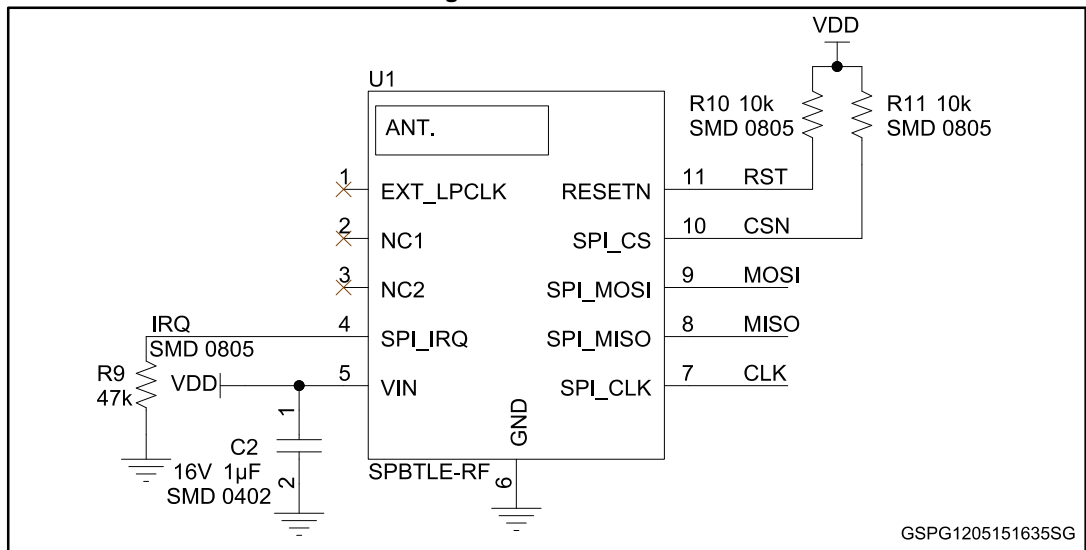

Figure 3: Nucleo connections

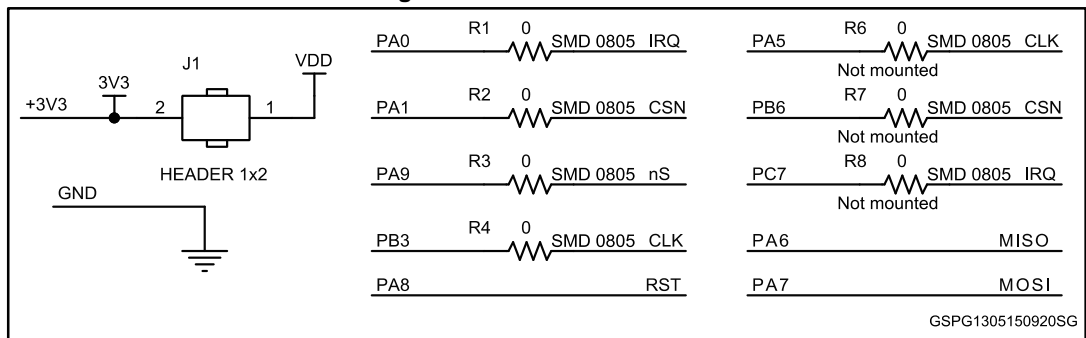
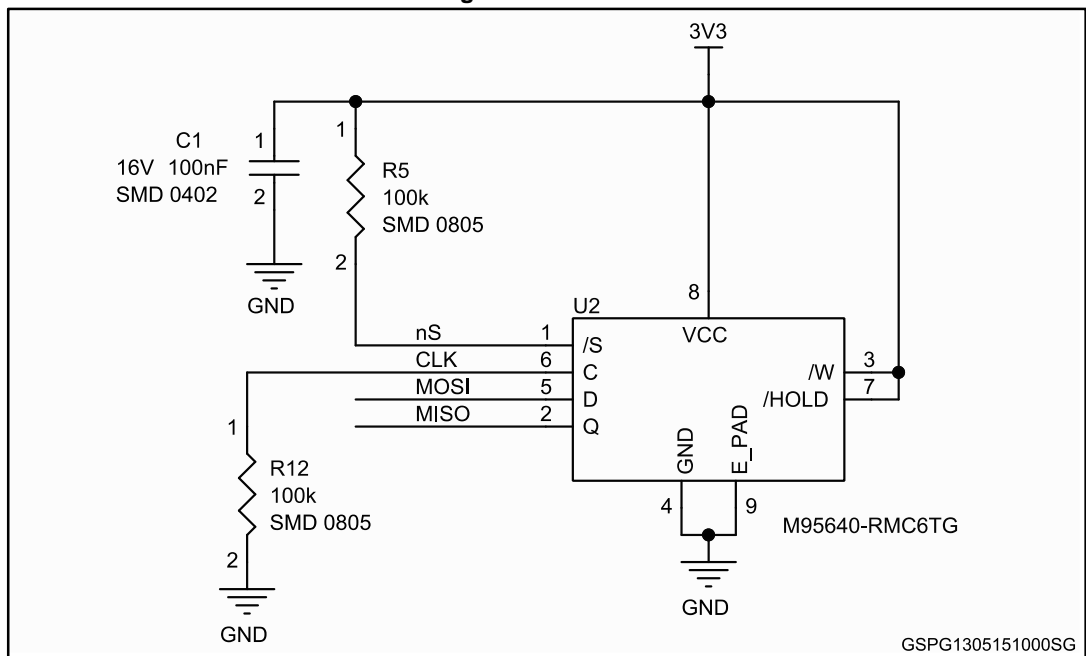

Figure 4: EEPROM



## 4 Revision history

Table 1: Document revision history

Date	Version	Changes
17-Jul-2015	1	Initial release.

**IMPORTANT NOTICE – PLEASE READ CAREFULLY**

STMicroelectronics NV and its subsidiaries (“ST”) reserve the right to make changes, corrections, enhancements, modifications, and improvements to ST products and/or to this document at any time without notice. Purchasers should obtain the latest relevant information on ST products before placing orders. ST products are sold pursuant to ST’s terms and conditions of sale in place at the time of order acknowledgement.

Purchasers are solely responsible for the choice, selection, and use of ST products and ST assumes no liability for application assistance or the design of Purchasers’ products.

No license, express or implied, to any intellectual property right is granted by ST herein.

Resale of ST products with provisions different from the information set forth herein shall void any warranty granted by ST for such product.



ST and the ST logo are trademarks of ST. All other product or service names are the property of their respective owners.

Information in this document supersedes and replaces information previously supplied in any prior versions of this document.

© 2015 STMicroelectronics – All rights reserved

## Looking for pricing, stock, or lifecycle information?

Click below to explore more details on WIN SOURCE:

-  [View X-NUCLEO-IDB05A1 on WIN SOURCE](#)
-  [STMicroelectronics Information](#)

## Optimize Your Supply Chain with WIN SOURCE Solutions

-  Global Sourcing Solution
-  Obsolete Management
-  Cost Control Management
-  Shortage Management
-  Alternative Solution
-  Excess Inventory Management