



**THE DATASHEET OF  
DAC7750IRHAT**



# DACx750 Single-Channel, 12- and 16-Bit Programmable Current Output Digital-to-Analog Converters for 4-mA to 20-mA Current Loop Applications

## 1 Features

- Current Output Options:
  - 0 mA to 24 mA
  - 4 mA to 20 mA
  - 0 mA to 20 mA
- ±0.1% FSR Typical Total Unadjusted Error (TUE)
- DNL: ±1 LSB Maximum
- Max Loop Compliance Voltage: AVDD – 2 V
- Internal 5-V Reference: 10 ppm/°C (Maximum)
- Internal 4.6-V Power-Supply Output
- CRC Frame Error Check
- Watchdog Timer
- Thermal Alarm
- Open Circuit Alarm
- Terminals to Monitor Output Current
- On-Chip Fault Alarm
- User-Calibration for Offset and Gain
- Wide Temperature Range: –40°C to 125°C
- 6-mm × 6-mm 40-Pin VQFN and 24-Pin HTSSOP Packages

## 2 Applications

- 4-mA to 20-mA Current Loops
- Analog Output Modules
- Building Automation
- Environment Monitoring
- Programmable Logic Controllers (PLCs)
- Field Sensors and Process Transmitters

## 3 Description

The DAC7750 and DAC8750 are low-cost, precision, fully-integrated 12-bit and 16-bit digital-to-analog converters (DACs) designed to meet the requirements of industrial process-control applications. These devices can be programmed as a current output with a range of 4 mA to 20 mA, 0 mA to 20 mA, or 0 mA to 24 mA. The DAC7750 and DAC8750 include reliability features such as CRC error checking on the serial peripheral interface (SPI™) frame, a watchdog timer, an open circuit, compliance voltage, and thermal alarm. In addition, the output current can be monitored by accessing an internal precision resistor.

These devices include a power-on-reset function to ensure that the device powers up in a known state (IOUT is disabled and in a Hi-Z state). The CLR terminal sets the current output to the low end of the range if the output is enabled. Program the zero and gain registers to digitally calibrate the device in the end system. The output slew rate is also programmable by register. These devices can superimpose an external HART® signal on the current output, and can operate with a 10-V to 36-V supply.

All versions are available in both 40-pin VQFN and 24-pin TSSOP packages.

### Device Information<sup>(1)</sup>

PART NUMBER	PACKAGE	BODY SIZE (NOM)
DACx750	HTSSOP (24)	7.80 mm × 4.40 mm
	VQFN (40)	6.00 mm × 6.00 mm

(1) For all available packages, see the orderable addendum at the end of the data sheet.

### Block Diagram

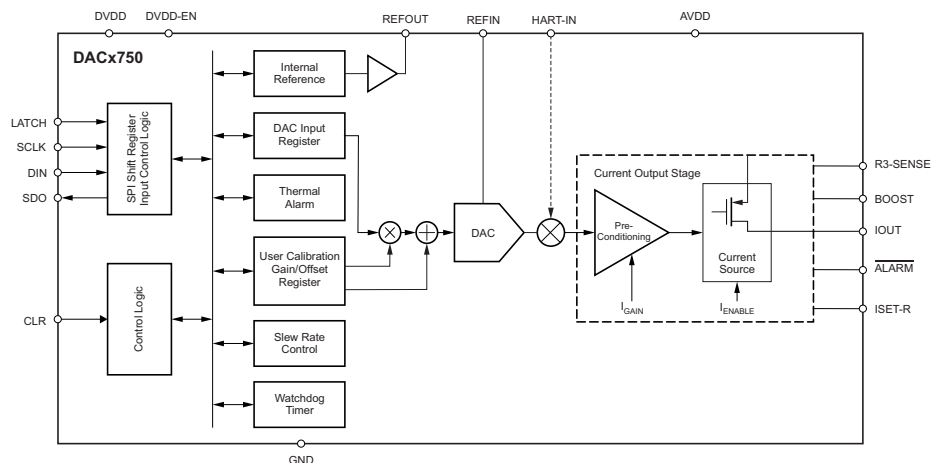

Copyright © 2016, Texas Instruments Incorporated



## Table of Contents

<b>1 Features</b> .....	<b>1</b>	8.4 Device Functional Modes .....	<b>29</b>
<b>2 Applications</b> .....	<b>1</b>	8.5 Programming .....	<b>31</b>
<b>3 Description</b> .....	<b>1</b>	8.6 Register Maps .....	<b>34</b>
<b>4 Revision History</b> .....	<b>2</b>	<b>9 Application and Implementation</b> .....	<b>37</b>
<b>5 Device Comparison Table</b> .....	<b>3</b>	9.1 Application Information .....	<b>37</b>
<b>6 Pin Configuration and Functions</b> .....	<b>3</b>	9.2 Typical Application .....	<b>39</b>
<b>7 Specifications</b> .....	<b>5</b>	<b>10 Power Supply Recommendations</b> .....	<b>41</b>
7.1 Absolute Maximum Ratings .....	<b>5</b>	<b>11 Layout</b> .....	<b>42</b>
7.2 ESD Ratings .....	<b>5</b>	11.1 Layout Guidelines .....	<b>42</b>
7.3 Recommended Operating Conditions .....	<b>5</b>	11.2 Layout Example .....	<b>42</b>
7.4 Thermal Information .....	<b>6</b>	11.3 Thermal Considerations .....	<b>43</b>
7.5 Electrical Characteristics .....	<b>6</b>	<b>12 Device and Documentation Support</b> .....	<b>44</b>
7.6 Electrical Characteristics: AC .....	<b>9</b>	12.1 Documentation Support .....	<b>44</b>
7.7 Timing Requirements: Write Mode .....	<b>9</b>	12.2 Related Links .....	<b>44</b>
7.8 Timing Requirements: Readback Mode .....	<b>9</b>	12.3 Receiving Notification of Documentation Updates .....	<b>44</b>
7.9 Timing Requirements: Daisy-Chain Mode .....	<b>10</b>	12.4 Community Resources .....	<b>44</b>
7.10 Typical Characteristics .....	<b>12</b>	12.5 Trademarks .....	<b>44</b>
<b>8 Detailed Description</b> .....	<b>20</b>	12.6 Electrostatic Discharge Caution .....	<b>44</b>
8.1 Overview .....	<b>20</b>	12.7 Glossary .....	<b>44</b>
8.2 Functional Block Diagram .....	<b>20</b>	<b>13 Mechanical, Packaging, and Orderable Information</b> .....	<b>45</b>
8.3 Feature Description .....	<b>21</b>		

## 4 Revision History

<b>Changes from Revision B (June 2016) to Revision C</b>	<b>Page</b>
• Changed description of <i>Power-Supply Sequence</i> section .....	<b>22</b>
• Added <i>The DACx750 Shares the SPI Bus With Other Devices</i> section .....	<b>24</b>
• Added first sentence to second paragraph and added last paragraph to <i>Frame Error Checking</i> section .....	<b>25</b>
• Added <i>The DACx750 Shares the SPI Bus With Other Devices</i> section .....	<b>26</b>
• Added last paragraph to <i>User Calibration</i> section .....	<b>27</b>
• Added last paragraph to <i>Programmable Slew Rate</i> section .....	<b>29</b>

<b>Changes from Revision A (March 2012) to Revision B</b>	<b>Page</b>
• Added <i>ESD Ratings</i> table, <i>Feature Description</i> section, <i>Device Functional Modes</i> , <i>Application and Implementation</i> section, <i>Power Supply Recommendations</i> section, <i>Layout</i> section, <i>Device and Documentation Support</i> section, and <i>Mechanical, Packaging, and Orderable Information</i> section .....	<b>1</b>
• Added I/O column to <i>Pin Functions</i> table .....	<b>4</b>
• Moved <i>Thermal Considerations</i> from <i>Power Supply Recommendations</i> to <i>Layout</i> .....	<b>43</b>

<b>Changes from Original (December 2013) to Revision A</b>	<b>Page</b>
• Changed format to meet latest data sheet standards; added new sections and moved existing sections .....	<b>1</b>
• Changed data sheet from 1-page product preview to full production data .....	<b>1</b>
• Updated Layout Schematic .....	<b>42</b>

## 5 Device Comparison Table

PRODUCT	RESOLUTION	TUE (FSR)	DIFFERENTIAL NONLINEARITY (LSB)	SPECIFIED TEMPERATURE RANGE
DAC8750	16	0.2%	±1	–40°C to 125°C
DAC7750	12	0.2%	±1	–40°C to 125°C

## 6 Pin Configuration and Functions

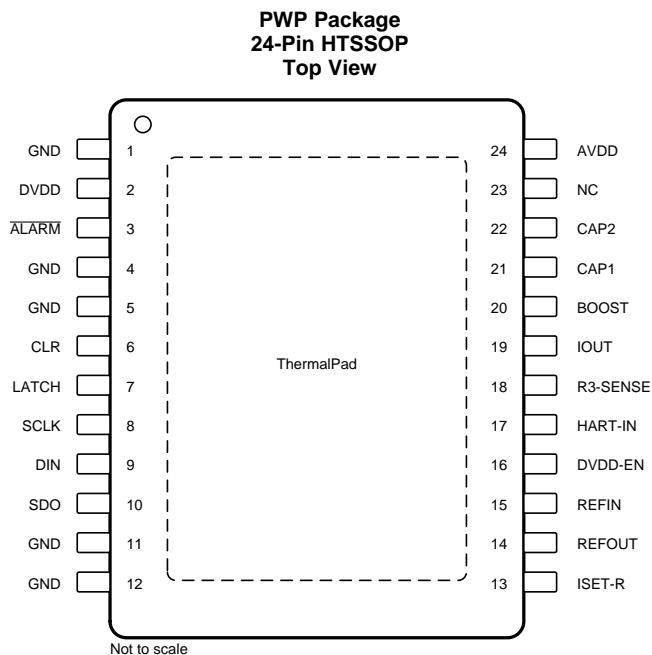
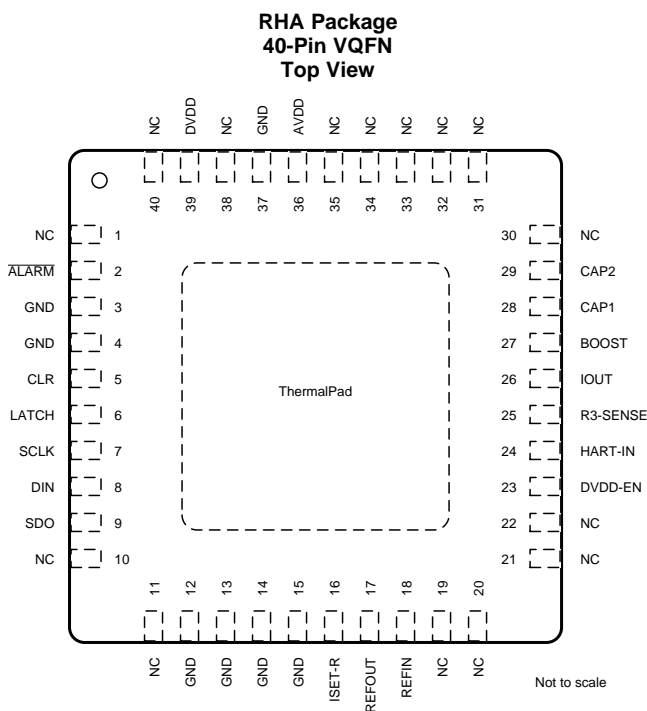

NOTE: Thermal pad is connected to ground.

### Pin Functions

NAME	PIN		I/O	DESCRIPTION
	VQFN	HTSSOP		
$\overline{\text{ALARM}}$	2	3	Digital output	Alarm terminal. Open drain output. External pull-up resistor required (10 k $\Omega$ ). The terminal goes low (active) when the $\overline{\text{ALARM}}$ condition is detected (open circuit/over temperature/timeout, and so forth).
AVDD	36	24	Supply input	Positive analog power supply.
BOOST	27	20	Analog output	Boost terminal. External transistor connection (optional).
CAP1	28	21	Analog input	Connection for output filtering capacitor (optional).
CAP2	29	22	Analog input	Connection for output filtering capacitor (optional).
CLR	5	6	Digital input	Clear input. Logic high on this terminal causes the part to enter CLEAR state. Active high.
DIN	8	9	Digital input	Serial data input. Data are clocked into the 24-bit input shift register on the rising edge of the serial clock input. Schmitt-Trigger logic input.
DVDD	39	2	Supply input or output	Digital power supply. Can be input or output, depending on DVDD-EN terminal.
DVDD-EN	23	16	Digital input	Internal power-supply enable terminal. Connect this terminal to GND to disable the internal supply, or leave this terminal unconnected to enable the internal supply. When this terminal is connected to GND, an external supply must be connected to the DVDD terminal.
GND	12, 13, 14, 15, 37	1, 11, 12	Supply input	Ground reference point for all analog circuitry of the device.
GND	3, 4	4, 5	Supply input	Ground reference point for all digital circuitry of the device.
HART-IN	24	17	Analog input	Input terminal for HART modulation.
IOUT	26	19	Analog output	Current output terminal
ISET-R	16	13	Analog input	Connection terminal for external precision resistor (15 k $\Omega$ ). See <a href="#">Detailed Description</a> of this data sheet.
LATCH	6	7	Digital input	Load DAC registers input. A rising edge on this terminal loads the input shift register data into the DAC data and control registers and updates the DAC output.
NC	1, 10, 11, 19, 20, 21, 22, 30, 31, 32, 33, 34, 35, 38, 40	23	—	No connection.
R3-SENSE	25	18	Analog output	This terminal is used as a monitoring feature for the output current. The voltage measured between the R3-SENSE terminal and the BOOST terminal is directly proportional to the output current.
REFOUT	17	14	Analog output	Internal reference output. Connects to REFIN when using internal reference.
REFIN	18	15	Analog input	Reference input
SCLK	7	8	Digital input	Serial clock input of the SPI. Data can be transferred at rates up to 30 MHz. Schmitt-Trigger logic input.
SDO	9	10	Digital output	Serial data output. Data are valid on the rising edge of SCLK.
Thermal Pad	—	—	Supply input	The thermal pad is internally connected to GND. It is recommended that the pad be thermally connected to a copper plane for enhanced thermal performance. The pad can be electrically connected to the same potential as the GND terminal or left electrically unconnected provided a supply connection is made at the GND terminal.

## 7 Specifications

### 7.1 Absolute Maximum Ratings

Over operating free-air temperature range (unless otherwise noted)<sup>(1)</sup>

	MIN	MAX	UNIT
AVDD to GND	-0.3	40	V
DVDD to GND	-0.3	6	V
IOUT to GND	-0.3	AVDD	V
REFIN to GND	-0.3	6	V
REFOUT to GND	-0.3	6	V
$\overline{\text{ALARM}}$ to GND	-0.3	6	V
Digital input voltage to GND	-0.3	DVDD + 0.3	V
SDO to GND	-0.3	DVDD + 0.3	V
Current into REFOUT		10	mA
Operating temperature	-40	125	°C
Junction temperature, $T_J$ max		150	°C
Storage temperature, $T_{\text{stg}}$	-65	150	°C

- (1) Stresses beyond those listed under *Absolute Maximum Ratings* may cause permanent damage to the device. These are stress ratings only, and functional operation of the device at these or any other conditions beyond those indicated under *Recommended Operating Conditions* is not implied. Exposure to absolute-maximum-rated conditions for extended periods may affect device reliability.

### 7.2 ESD Ratings

		VALUE	UNIT
$V_{\text{ESD}}$ Electrostatic discharge <sup>(1)</sup>	Human body model (HBM) ESD stress voltage <sup>(2)</sup>	±3000	V
	Charged device model (CDM) ESD stress voltage <sup>(3)</sup>	±1000	

- (1) Electrostatic discharge (ESD) to measure device sensitivity and immunity to damage caused by assembly line electrostatic discharges in to the device.
- (2) JEDEC document JEP155 states that 500-V HBM allows safe manufacturing with a standard ESD control process. Manufacturing with less than 500-V HBM is possible with the necessary precautions.
- (3) JEDEC document JEP157 states that 250-V CDM allows safe manufacturing with a standard ESD control process. Manufacturing with less than 250-V CDM is possible with the necessary precautions.

### 7.3 Recommended Operating Conditions

	MIN	NOM	MAX	UNIT
AVDD	10		36	V
DVDD	2.7		5.5	V
Loop compliance voltage	4.95		5.05	V
Reference input voltage		30		μA
Loop compliance voltage (output = 24 mA) <sup>(1)</sup>			AVDD – 2	V
V <sub>IH</sub> , Digital input high voltage	2			V
V <sub>IL</sub> , Digital Input low voltage	3.6 V < AVDD < 5.5 V		0.8	V
	2.7 V < AVDD < 2.6 V		0.6	
Specified performance temperature	-40		125	°C

- (1) Loop compliance voltage is defined as the voltage at the IOUT pin

## 7.4 Thermal Information

THERMAL METRIC <sup>(1)</sup>		DAC7750, DAC8750		UNIT
		RHA (VQFN)	PWP (HTSSOP)	
		40 PINS	24 PINS	
R <sub>θJA</sub>	Junction-to-ambient thermal resistance	32.9	32.3	°C/W
R <sub>θJC(top)</sub>	Junction-to-case (top) thermal resistance	17.2	14.1	°C/W
R <sub>θJB</sub>	Junction-to-board thermal resistance	7.5	12.2	°C/W
ψ <sub>JT</sub>	Junction-to-top characterization parameter	0.2	0.3	°C/W
ψ <sub>JB</sub>	Junction-to-board characterization parameter	7.5	12	°C/W
R <sub>θJC(bot)</sub>	Junction-to-case (bottom) thermal resistance	1.4	0.63	°C/W

(1) For more information about traditional and new thermal metrics, see the [Semiconductor and IC Package Thermal Metrics](#) application report.

## 7.5 Electrical Characteristics

At AVDD = 10 V to 36 V, GND = 0 V, REFIN = 5 V external, DVDD = 2.7 V to 5.5 V, and all specifications are from –40°C to 125°C (unless otherwise noted). For IOUT, R<sub>L</sub> = 300 Ω. Typical specifications are at 25°C.

PARAMETER	TEST CONDITIONS	MIN	TYP	MAX	UNIT	
<b>CURRENT OUTPUT</b>						
Current output		0		24	mA	
		0		20		
		4		20		
Resolution	DAC8750	16			Bits	
	DAC7750	12				
<b>CURRENT OUTPUT ACCURACY (0 mA TO 20 mA AND 0 mA TO 24 mA)<sup>(1)</sup></b>						
Total unadjusted error, TUE	T <sub>A</sub> = –40°C to 125°C	–0.2%		0.2%	FSR	
	T <sub>A</sub> = –40°C to 85°C	–0.16%		0.16%		
	T <sub>A</sub> = 25°C	–0.08%	±0.02%	0.08%		
Differential nonlinearity, DNL	Monotonic			±1	LSB	
Relative accuracy, INL <sup>(2)</sup>	T <sub>A</sub> = –40°C to 125°C			±0.08%	FSR	
	T <sub>A</sub> = –40°C to 85°C			±0.024%		
Offset error	T <sub>A</sub> = –40°C to 125°C	–0.17%		0.17%	FSR	
	T <sub>A</sub> = –40°C to 85°C	–0.1%		0.1%		
	T <sub>A</sub> = 25°C	–0.07%	±0.01%	0.07%		
Offset error temperature coefficient			±5		ppm FSR/°C	
Full-scale error	T <sub>A</sub> = –40°C to 125°C	–0.2%		0.2%	FSR	
	T <sub>A</sub> = –40°C to 85°C	–0.16%		0.16%		
	T <sub>A</sub> = 25°C	–0.08%	±0.015%	0.08%		
Full-scale error temperature coefficient	Internal R <sub>SET</sub>		±5		ppm FSR/°C	
	External R <sub>SET</sub>		±10			
Gain error	Internal R <sub>SET</sub>	T <sub>A</sub> = –40°C to 125°C	–0.2%		0.2%	FSR
		T <sub>A</sub> = –40°C to 85°C	–0.15%		0.15%	
		T <sub>A</sub> = 25°C	–0.08%	±0.01%	0.08%	
	External R <sub>SET</sub>	T <sub>A</sub> = –40°C to 125°C	–0.17%		0.17%	
		T <sub>A</sub> = –40°C to 85°C	–0.12%		0.12%	
		T <sub>A</sub> = 25°C	–0.05%	±0.01%	0.05%	
Gain error temperature coefficient	Internal R <sub>SET</sub>		±3		ppm FSR/°C	
	External R <sub>SET</sub>		±8			
Output current drift vs time	T <sub>A</sub> = 125°C, 1000 hrs	Internal R <sub>SET</sub>		±50	ppm FSR	
		External R <sub>SET</sub>		±25		

(1) DAC8750 and DAC7750 current output range is set by writing to RANGE bits in control register at address 0x55.

(2) For 0-mA to 20-mA and 0-mA to 24-mA ranges, INL is calculated beginning from code 0x0100 for DAC8750 and from code 0x0010 for DAC7750.

## Electrical Characteristics (continued)

At AVDD = 10 V to 36 V, GND = 0 V, REFIN = 5 V external, DVDD = 2.7 V to 5.5 V, and all specifications are from –40°C to 125°C (unless otherwise noted). For IOU, R<sub>L</sub> = 300 Ω. Typical specifications are at 25°C.

PARAMETER	TEST CONDITIONS		MIN	TYP	MAX	UNIT
<b>CURRENT OUTPUT ACCURACY (4 mA TO 20 mA)<sup>(1)</sup></b>						
Total unadjusted error, TUE	Internal R <sub>SET</sub>	T <sub>A</sub> = –40°C to 125°C	–0.25%		0.25%	FSR
		T <sub>A</sub> = 25°C	–0.08%	±0.02%	0.08%	
	External R <sub>SET</sub>	T <sub>A</sub> = –40°C to 125°C	–0.29%		0.29%	
		T <sub>A</sub> = –40°C to 85°C	–0.25%		0.25%	
		T <sub>A</sub> = 25°C	–0.1%	±0.02%	0.1%	
Differential nonlinearity, DNL	Monotonic				±1	LSB
Relative accuracy, INL <sup>(2)</sup>	T <sub>A</sub> = –40°C to 125°C				±0.08%	FSR
	T <sub>A</sub> = –40°C to 85°C				±0.024%	
Offset error	Internal R <sub>SET</sub>	T <sub>A</sub> = –40°C to 125°C	–0.22%		0.22%	FSR
		T <sub>A</sub> = –40°C to 85°C	–0.2%		0.2%	
	External R <sub>SET</sub>	T <sub>A</sub> = –40°C to 125°C	–0.2%		0.2%	
		T <sub>A</sub> = –40°C to 85°C	–0.18%		0.18%	
	Internal and external R <sub>SET</sub> , T <sub>A</sub> = 25°C		–0.07%	±0.01%	0.07%	
Offset error temperature coefficient				±3		ppm FSR/°C
Full-scale error	Internal R <sub>SET</sub>	T <sub>A</sub> = –40°C to 125°C	–0.25%		0.25%	FSR
		T <sub>A</sub> = 25°C	–0.08%	±0.015%	0.08%	
	External R <sub>SET</sub>	T <sub>A</sub> = –40°C to 125°C	–0.29%		0.29%	
		T <sub>A</sub> = –40°C to 85°C	–0.25%		0.25%	
		T <sub>A</sub> = 25°C	–0.1%	±0.015%	0.1%	
Full-scale error temperature coefficient	Internal R <sub>SET</sub>			±5		ppm FSR/°C
	External R <sub>SET</sub>			±10		
Gain error	Internal R <sub>SET</sub>	T <sub>A</sub> = –40°C to 125°C	–0.2%		0.2%	FSR
		T <sub>A</sub> = –40°C to 85°C	–0.15%		0.15%	
		T <sub>A</sub> = 25°C	–0.08%	±0.01%	0.08%	
	External R <sub>SET</sub>	T <sub>A</sub> = –40°C to 125°C	–0.16%		0.16%	
		T <sub>A</sub> = –40°C to 85°C	–0.12%		0.12%	
		T <sub>A</sub> = 25°C	–0.05%	±0.01%	0.05%	
Gain error temperature coefficient	Internal R <sub>SET</sub>			±3		ppm FSR/°C
	External R <sub>SET</sub>			±8		
Output current drift vs time	T <sub>A</sub> = 125°C, 1000 hrs	Internal R <sub>SET</sub>		±50		ppm FSR
		External R <sub>SET</sub>		±75		
<b>CURRENT OUTPUT STAGE<sup>(3)</sup></b>						
Loop compliance voltage <sup>(4)</sup>	Output = 24 mA				AVDD – 2	V
Inductive load <sup>(5)</sup>				50		mH
DC PSRR					1	μA/V
Output impedance	Code = 0x8000			50		MΩ
<b>R3 RESISTOR</b>						
R3 resistor value			36	40	44	Ω
R3 resistor temperature coefficient				40		ppm/°C
<b>EXTERNAL REFERENCE INPUT</b>						
Reference input voltage			4.95	5	5.05	V
External reference current	REFIN = 5.0 V			30		μA
Reference input capacitance				10		pF

(3) Specified by design and characterization; not production tested.

(4) Loop compliance voltage is defined as the voltage at the IOU terminal.

(5) For stability, use slew rate limit feature or add a capacitor between IOU and GND

**Electrical Characteristics (continued)**

At AVDD = 10 V to 36 V, GND = 0 V, REFIN = 5 V external, DVDD = 2.7 V to 5.5 V, and all specifications are from –40°C to 125°C (unless otherwise noted). For IOU<sub>T</sub>, R<sub>L</sub> = 300 Ω. Typical specifications are at 25°C.

PARAMETER	TEST CONDITIONS	MIN	TYP	MAX	UNIT
<b>INTERNAL REFERENCE OUTPUT</b>					
Reference output	T <sub>A</sub> = 25°C	4.995		5.005	V
Reference temperature coefficient <sup>(3)</sup>	T <sub>A</sub> = –40°C to 85°C			±10	ppm/°C
Output noise (0.1 Hz to 10 Hz)	T <sub>A</sub> = 25°C		14		μV <sub>PP</sub>
Noise spectral density	T <sub>A</sub> = 25°C, 10 kHz		185		nV/√Hz
Capacitive load			600		nF
Load current			±5		mA
Short-circuit current	REFOUT shorted to GND		25		mA
Load regulation	AVDD = 24 V, T <sub>A</sub> = 25°C, sourcing		55		μV/mA
	AVDD = 24 V, T <sub>A</sub> = 25°C, sinking		120		
Line regulation			±1.2		μV/V
<b>DVDD INTERNAL REGULATOR</b>					
Output voltage	AVDD = 24 V		4.6		V
Output load current <sup>(3)</sup>				10	mA
Load regulation			3.5		mV/mA
Line regulation			1		mV/V
Short-circuit current	AVDD = 24 V, to GND		35		mA
Capacitive load stability <sup>(3)</sup>				2.5	μF
<b>DIGITAL INPUTS</b>					
High-level input voltage, V <sub>IH</sub>		2			V
Low-level input voltage, V <sub>IL</sub>	3.6 V < AVDD < 5.5 V			0.8	V
	2.7 V < AVDD < 3.6 V			0.6	
Hysteresis voltage			0.4		V
Input current	DVDD-EN, V <sub>IN</sub> ≤ 5 V	–2.7			μA
	All terminals other than DVDD-EN			±1	
Terminal capacitance	Per terminal		10		pF
<b>DIGITAL OUTPUTS</b>					
SDO	Low-level output voltage, V <sub>OL</sub> , sinking 200 μA			0.4	V
	High-level output voltage, V <sub>OH</sub> , sourcing 200 μA	DVDD – 0.5			
	High-impedance leakage			±1	
ALARM	Low-level output voltage, V <sub>OL</sub>	10-kΩ pullup resistor to DVDD		0.4	V
		2.5 mA		0.6	
	High-impedance leakage			±1	μA
High-impedance output capacitance			10		pF
<b>POWER SUPPLY</b>					
AVDD		10		36	V
DVDD	Internal regulator disabled	2.7		5.5	V
AIDD	Outputs disabled, external DVDD			3	mA
	Outputs disabled, internal DVDD			4	
	Code = 0x0000, IOU <sub>T</sub> enabled			3	
DIDD	V <sub>IH</sub> = DVDD, V <sub>IL</sub> = GND, interface idle			1	mA
Power dissipation	AVDD = 36 V, IOU <sub>T</sub> = 0 mA, DVDD = 5 V		95	115	mW
<b>TEMPERATURE</b>					
Thermal alarm			142		°C
Thermal alarm hysteresis			18		°C

## 7.6 Electrical Characteristics: AC

At AVDD = 10 V to 36 V, GND = 0 V, REFIN = 5 V external and DVDD = 2.7 V to 5.5 V. For IOUT,  $R_L = 300 \Omega$ . All specifications –40°C to 125°C (unless otherwise noted). Typical specifications are at 25°C.

PARAMETER <sup>(1)</sup>	TEST CONDITIONS	MIN	TYP	MAX	UNIT
<b>DYNAMIC PERFORMANCE</b>					
Output current settling time	16-mA step, to 0.1% FSR, no L (inductance)		10		$\mu$ s
	16-mA step, to 0.1% FSR, L < 1 mH		25		$\mu$ s
AC PSRR	200-mV, 50-Hz or 60-Hz sine wave superimposed on power-supply voltage		–75		dB

(1) Specified by characterization, not production tested.

## 7.7 Timing Requirements: Write Mode

at  $T_A = -40^\circ\text{C}$  to  $125^\circ\text{C}$  and DVDD = 2.7 V to 5.5 V (unless otherwise noted)<sup>(1)</sup>

		MIN	MAX	UNIT
$t_1$	SCLK cycle time	33		ns
$t_2$	SCLK low time	13		ns
$t_3$	SCLK high time	13		ns
$t_4$	LATCH delay time	13		ns
$t_5$	LATCH high time <sup>(2)</sup>	40		ns
$t_6$	Data setup time	5		ns
$t_7$	Data hold time	7		ns
$t_8$	LATCH low time	40		ns
$t_9$	CLR pulse duration	20		ns
$t_{10}$	CLR activation time		5	$\mu$ s

(1) Specified by design, not production tested.

(2) Based on digital interface circuitry only. When writing to DAC control and configuration registers, consider the analog output specifications in [Electrical Characteristics: AC](#).

## 7.8 Timing Requirements: Readback Mode

at  $T_A = -40^\circ\text{C}$  to  $125^\circ\text{C}$  and DVDD = 2.7 V to 5.5 V (unless otherwise noted)<sup>(1)</sup>

		MIN	MAX	UNIT
$t_{11}$	SCLK cycle time	60		ns
$t_{12}$	SCLK low time	25		ns
$t_{13}$	SCLK high time	25		ns
$t_{14}$	LATCH delay time	13		ns
$t_{15}$	LATCH high time	40		ns
$t_{16}$	Data setup time	5		ns
$t_{17}$	Data hold time	7		ns
$t_{18}$	LATCH low time	40		ns
$t_{19}$	Serial output delay time ( $C_{L, SDO} = 15 \text{ pF}$ )		35	ns
$t_{20}$	LATCH rising edge to SDO 3-state ( $C_{L, SDO} = 15 \text{ pF}$ )		35	ns

(1) Specified by design, not production tested.

## 7.9 Timing Requirements: Daisy-Chain Mode

 at  $T_A = -40^\circ\text{C}$  to  $125^\circ\text{C}$  and  $DVDD = 2.7\text{ V}$  to  $5.5\text{ V}$  (unless otherwise noted)<sup>(1)</sup>

		MIN	MAX	UNIT
$t_{21}$	SCLK cycle time	60		ns
$t_{22}$	SCLK low time	25		ns
$t_{23}$	SCLK high time	25		ns
$t_{24}$	LATCH delay time	13		ns
$t_{25}$	LATCH high time	40		ns
$t_{26}$	Data setup time	5		ns
$t_{27}$	Data hold time	7		ns
$t_{28}$	LATCH low time	40		ns
$t_{29}$	Serial output delay time ( $C_{L, SDO} = 15\text{ pF}$ )		35	ns

(1) Specified by design, not production tested.

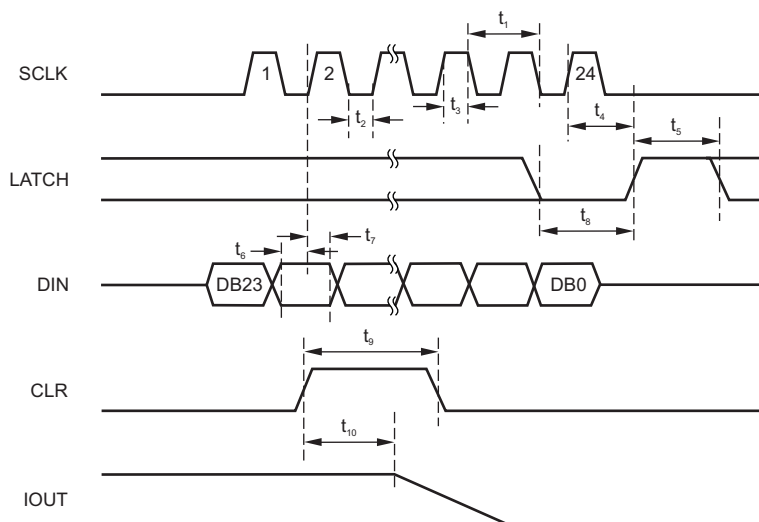
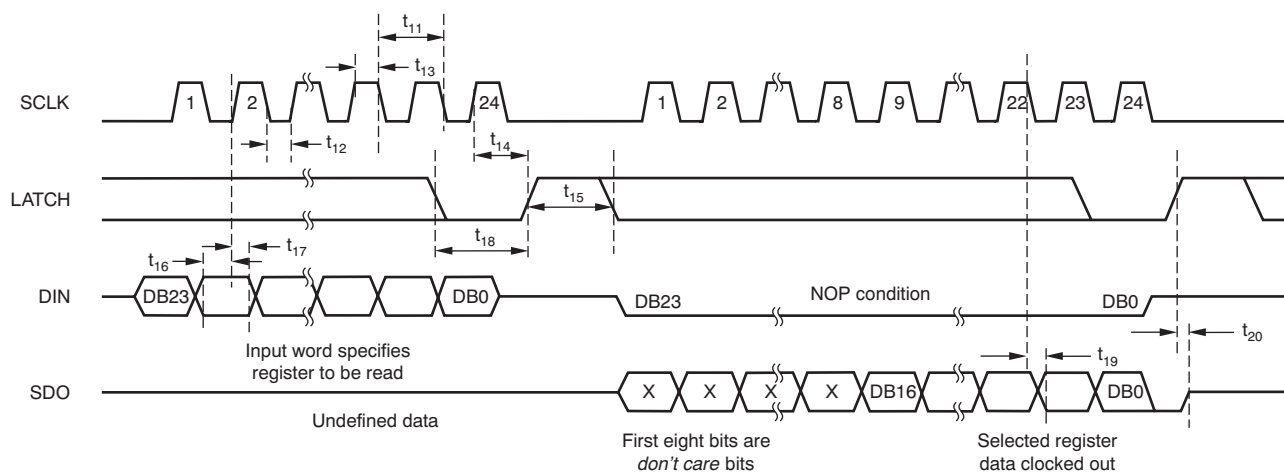
**Figure 1. Write Mode Timing**

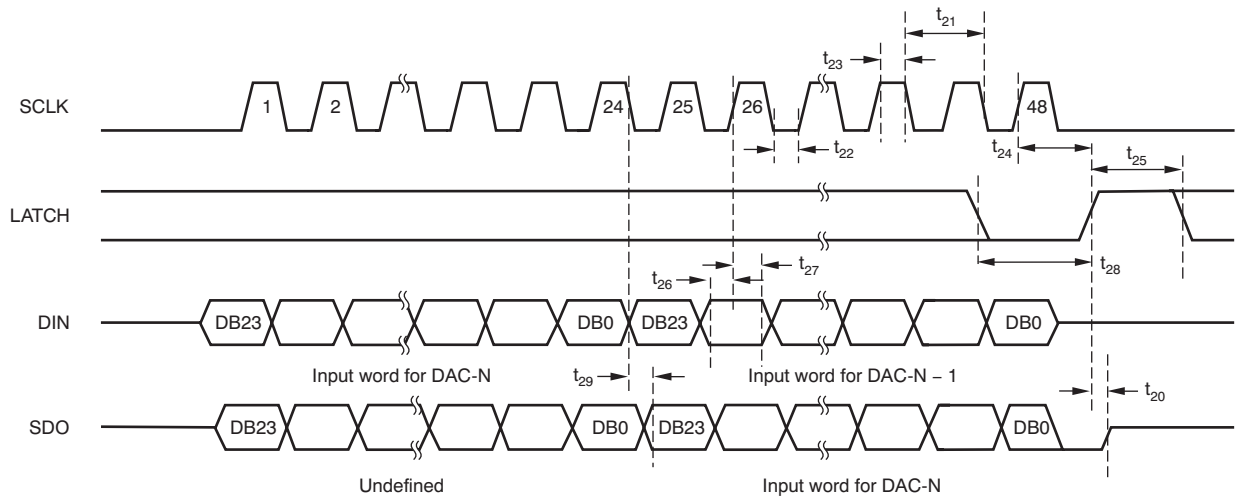
**Figure 2. Readback Mode Timing**



**Figure 3. Daisy-Chain Mode Timing**

DAC7750, DAC8750

SBAS538C – DECEMBER 2013 – REVISED JANUARY 2018

www.ti.com

7.10 Typical Characteristics

at  $T_A = 25^\circ\text{C}$  (unless otherwise noted)

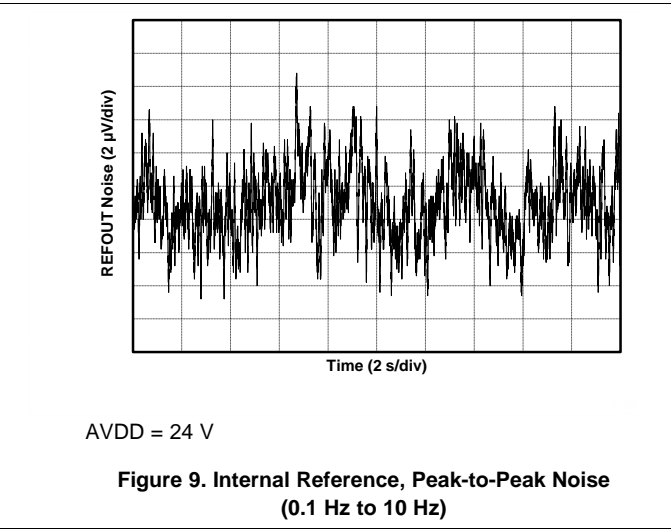
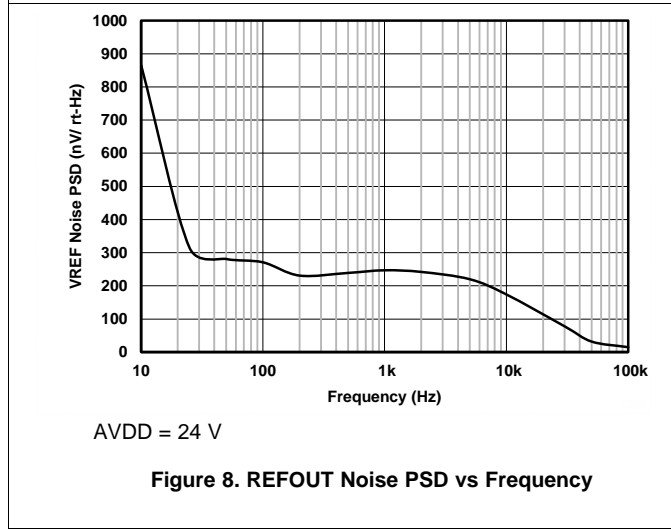
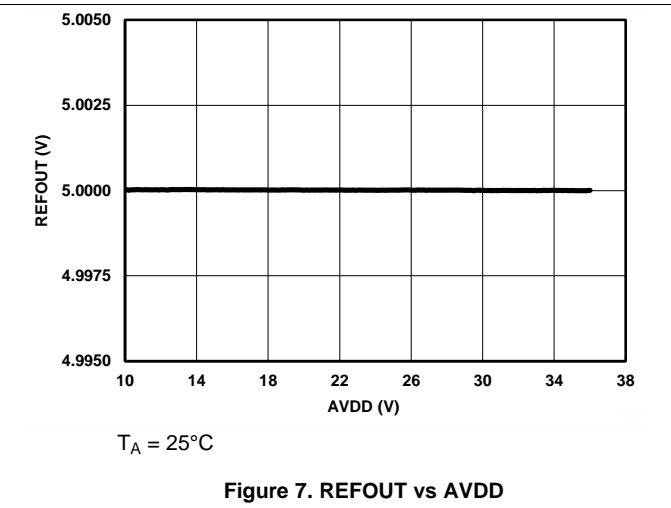
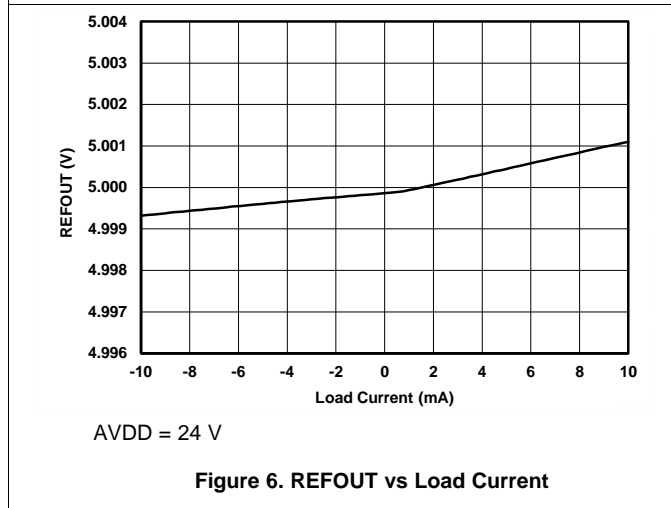
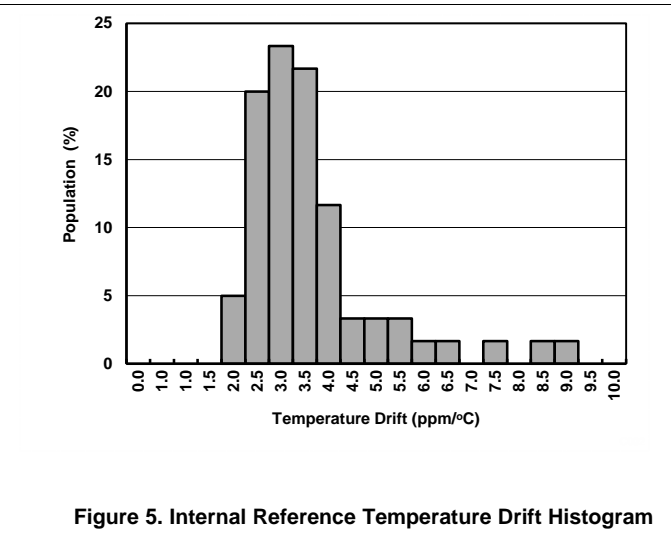
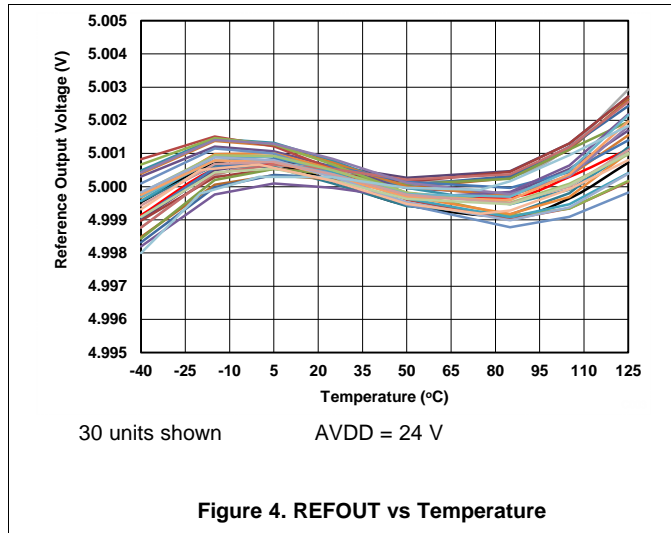

Typical Characteristics (continued)

at  $T_A = 25^\circ\text{C}$  (unless otherwise noted)

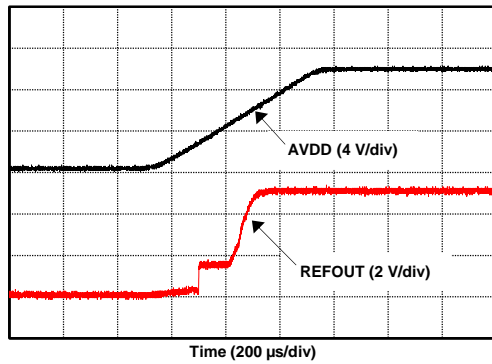

AVDD = 10 V

Figure 10. REFOUT Transient vs Time

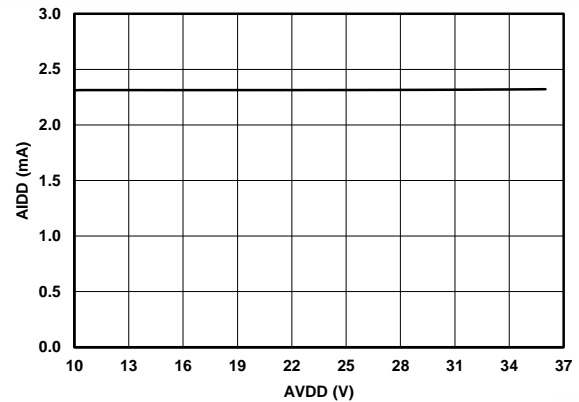

External DVDD IOUT = 0 mA

Figure 11. AIDD vs AVDD

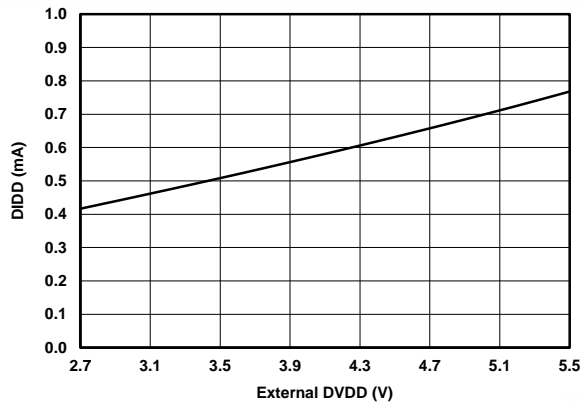

$T_A = 25^\circ\text{C}$  External DVDD

Figure 12. DIDD vs External DVDD

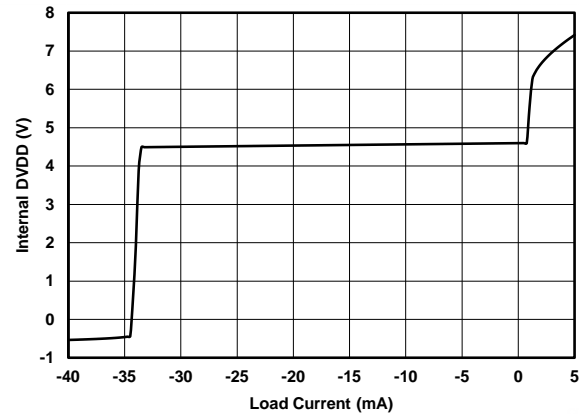

$T_A = 25^\circ\text{C}$  Internal DVDD

Figure 13. Internal DVDD vs Load Current

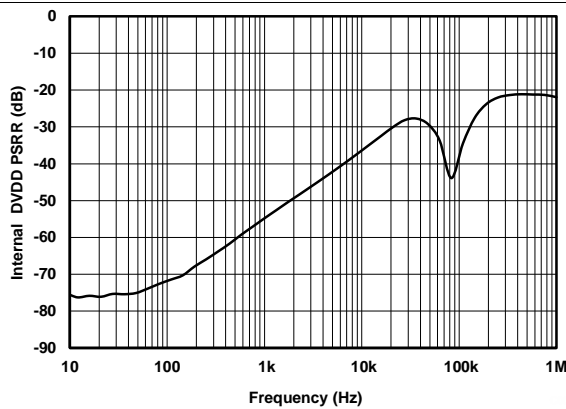

AVDD = 18 V  $C_{LOAD} = 100 \text{ nF}$

Figure 14. Internal DVDD PSRR vs Frequency

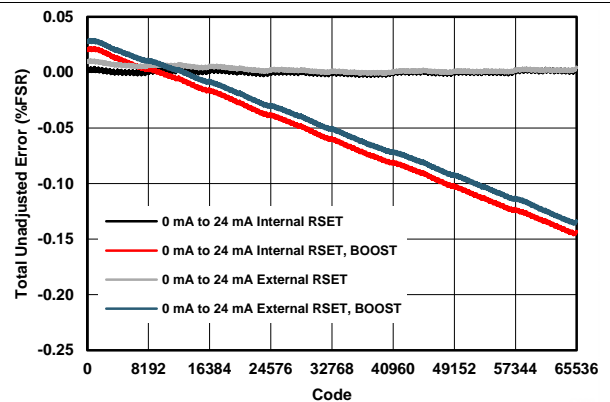

AVDD = 24 V  $R_{LOAD} = 300 \Omega$

Figure 15. IOUT TUE vs Code (0 mA to 24 mA)

### Typical Characteristics (continued)

at  $T_A = 25^\circ\text{C}$  (unless otherwise noted)

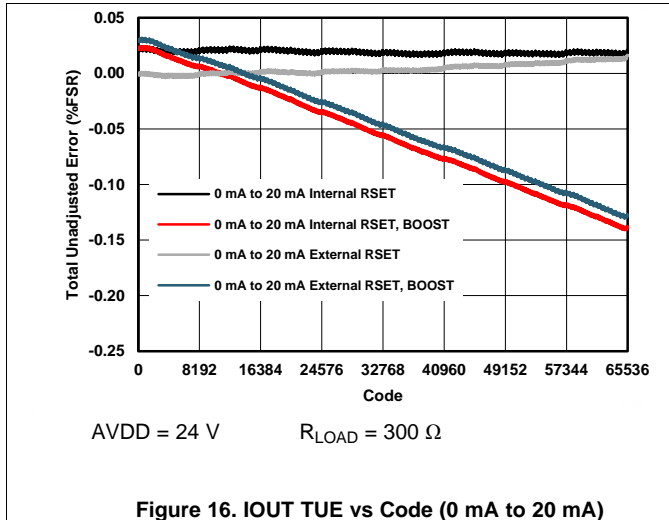

Figure 16. IOUT TUE vs Code (0 mA to 20 mA)

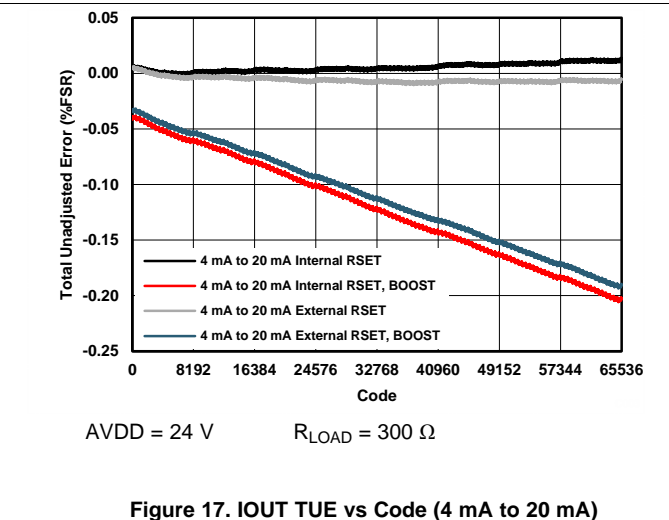

Figure 17. IOUT TUE vs Code (4 mA to 20 mA)

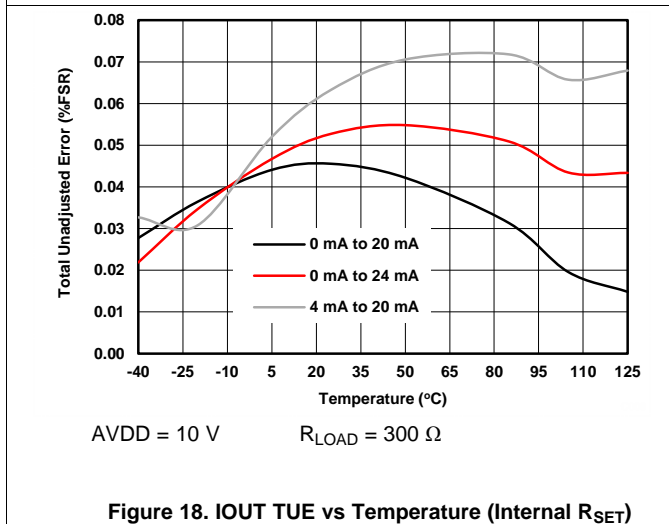

Figure 18. IOUT TUE vs Temperature (Internal  $R_{SET}$ )

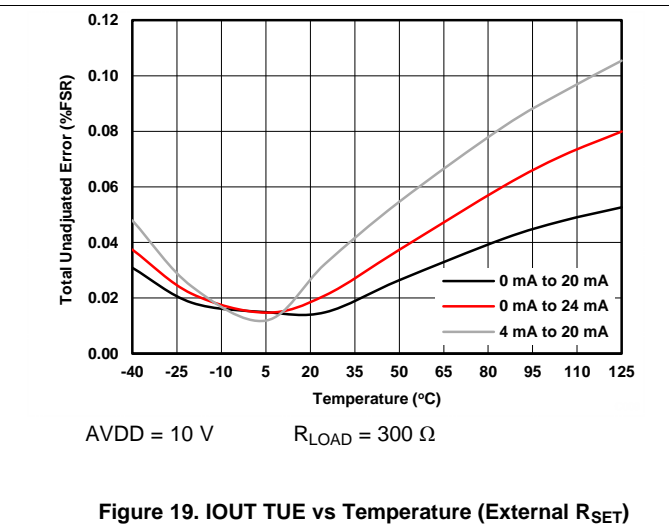

Figure 19. IOUT TUE vs Temperature (External  $R_{SET}$ )

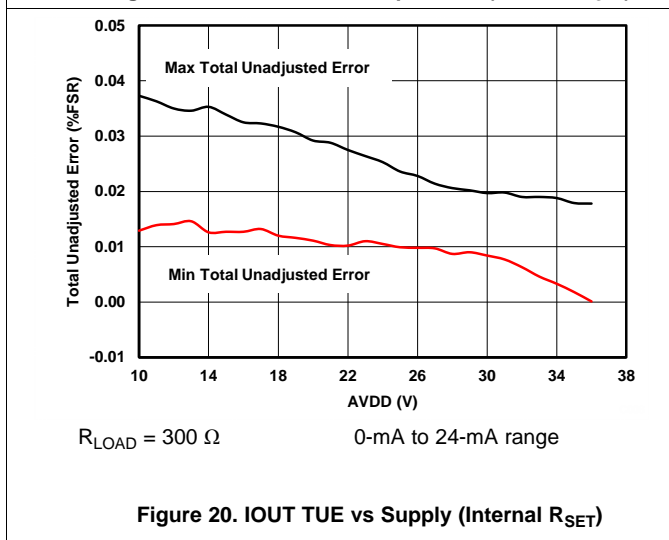

Figure 20. IOUT TUE vs Supply (Internal  $R_{SET}$ )

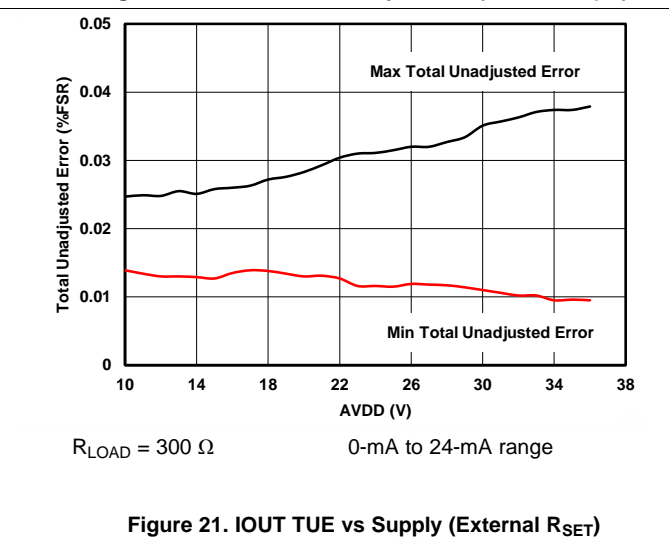

Figure 21. IOUT TUE vs Supply (External  $R_{SET}$ )

Typical Characteristics (continued)

at  $T_A = 25^\circ\text{C}$  (unless otherwise noted)

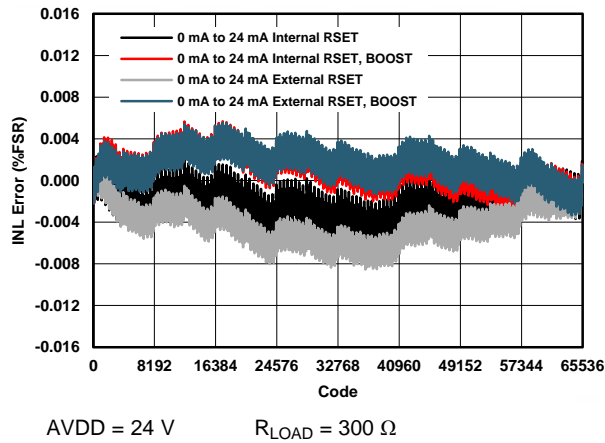

Figure 22. IOUT INL vs Code (0 mA to 24 mA)

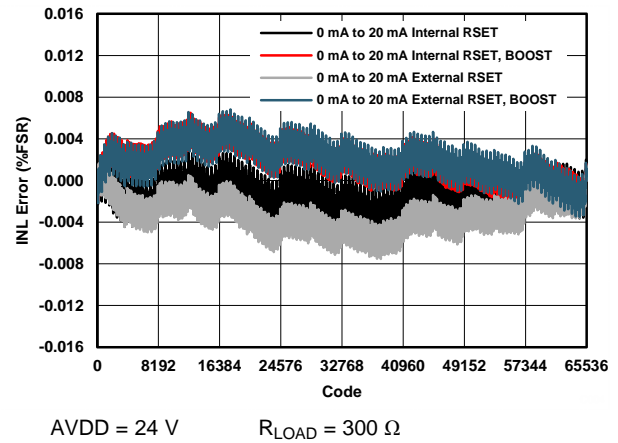

Figure 23. IOUT INL vs Code (0 mA to 20 mA)

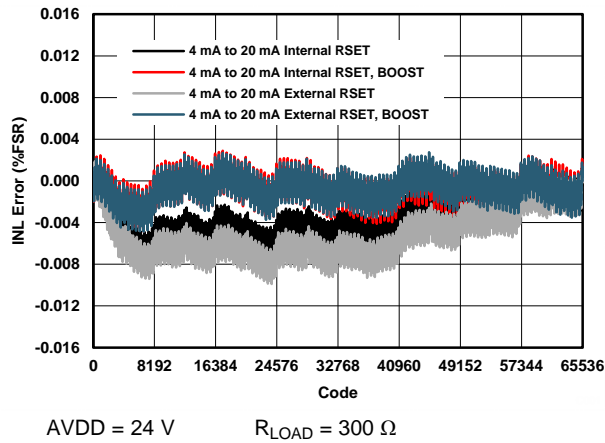

Figure 24. IOUT INL vs Code (4 mA to 20 mA)

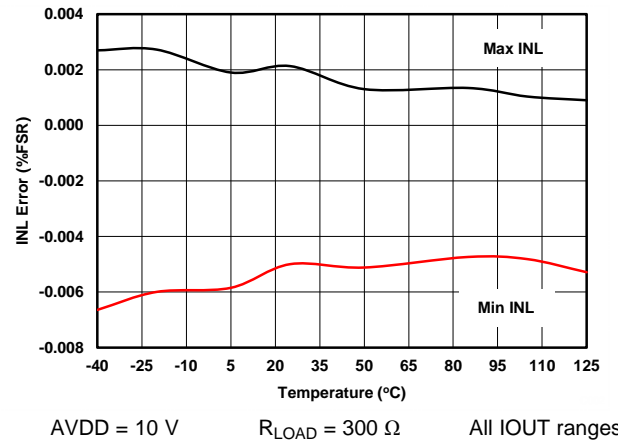

Figure 25. IOUT INL vs Temperature (Internal  $R_{SET}$ )

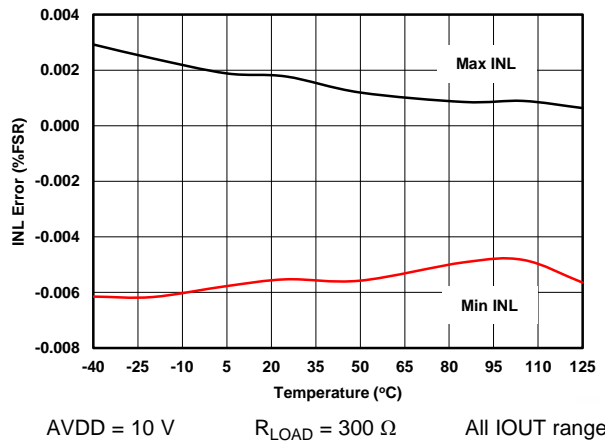

Figure 26. IOUT INL vs Temperature (External  $R_{SET}$ )

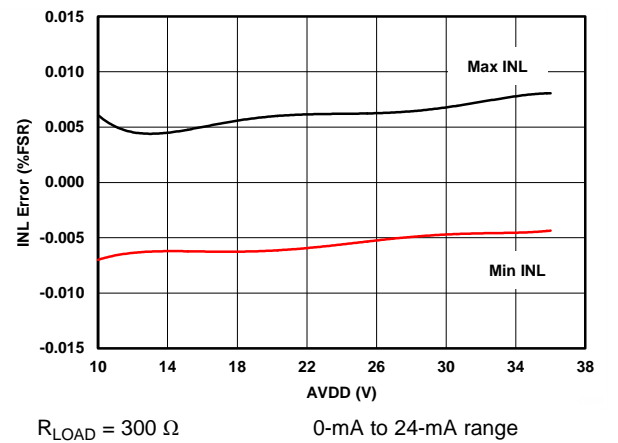
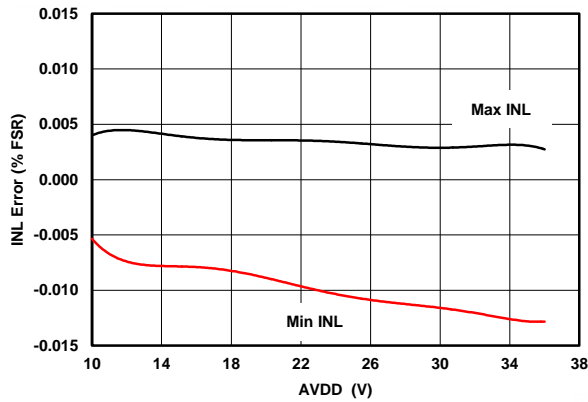

Figure 27. IOUT INL vs Supply (Internal  $R_{SET}$ )

### Typical Characteristics (continued)

at  $T_A = 25^\circ\text{C}$  (unless otherwise noted)



$R_{LOAD} = 300\ \Omega$       0-mA to 24-mA range

Figure 28. IOUT INL vs Supply (External  $R_{SET}$ )

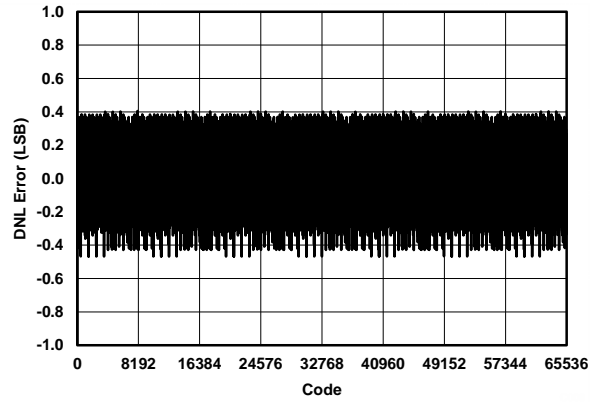

$AVDD = 24\ \text{V}$       0-mA to 24-mA range  
 $R_{LOAD} = 300\ \Omega$

Figure 29. IOUT DNL vs Code (0 mA to 24 mA)

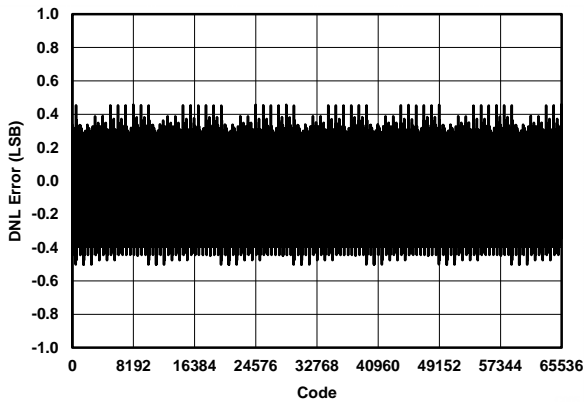

$AVDD = 24\ \text{V}$       0-mA to 24-mA range  
 $R_{LOAD} = 300\ \Omega$

Figure 30. IOUT DNL vs Code (0 mA to 20 mA)

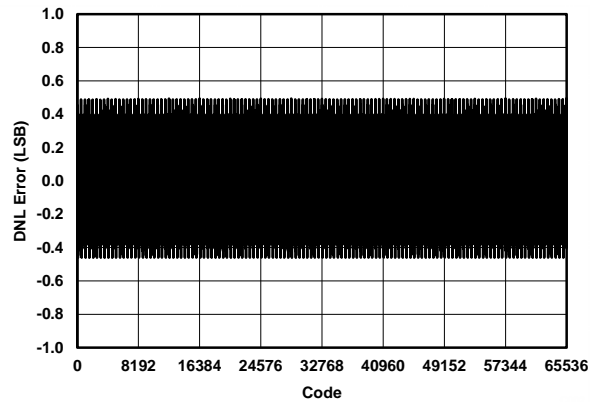

$AVDD = 24\ \text{V}$       4-mA to 24-mA range  
 $R_{LOAD} = 300\ \Omega$

Figure 31. IOUT DNL vs Code (4 mA to 20 mA)

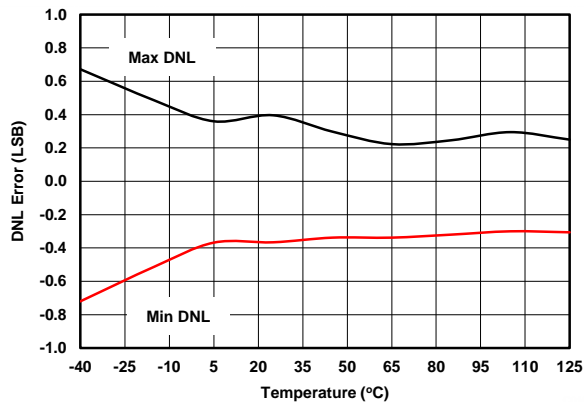

$AVDD = 10\ \text{V}$        $R_{LOAD} = 300\ \Omega$       All IOUT ranges

Figure 32. IOUT DNL vs Temperature (Internal  $R_{SET}$ )

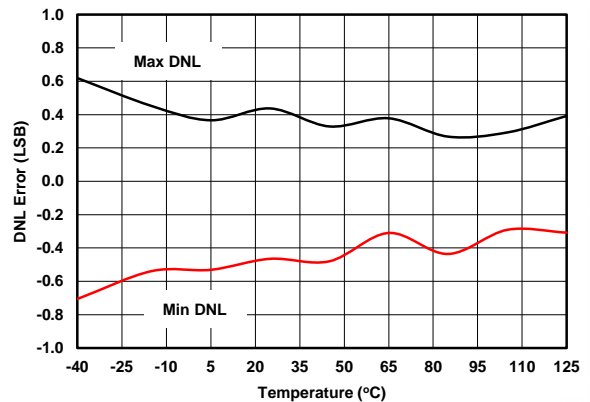

$AVDD = 10\ \text{V}$        $R_{LOAD} = 300\ \Omega$       All IOUT ranges

Figure 33. IOUT DNL vs Temperature (External  $R_{SET}$ )

Typical Characteristics (continued)

at  $T_A = 25^\circ\text{C}$  (unless otherwise noted)

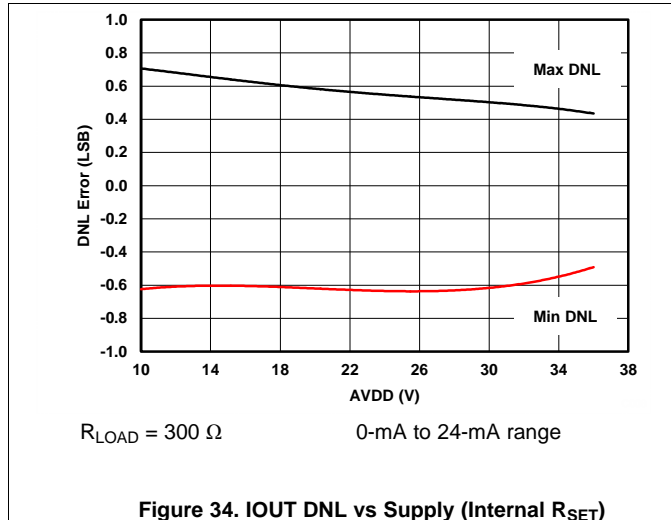

Figure 34. IOUT DNL vs Supply (Internal RSET)

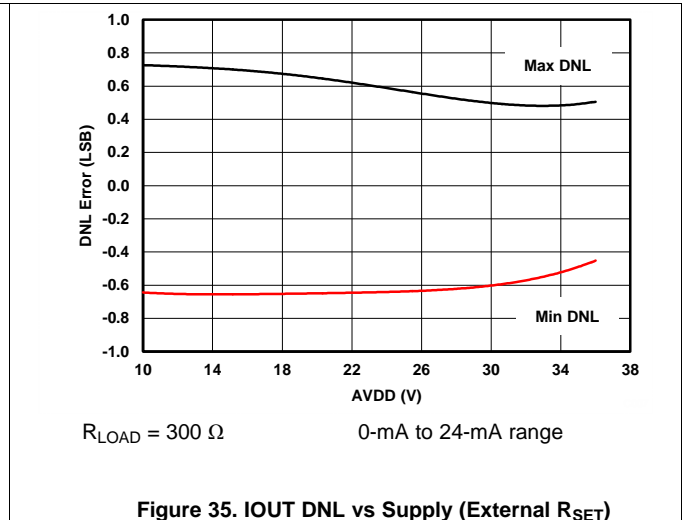

Figure 35. IOUT DNL vs Supply (External RSET)

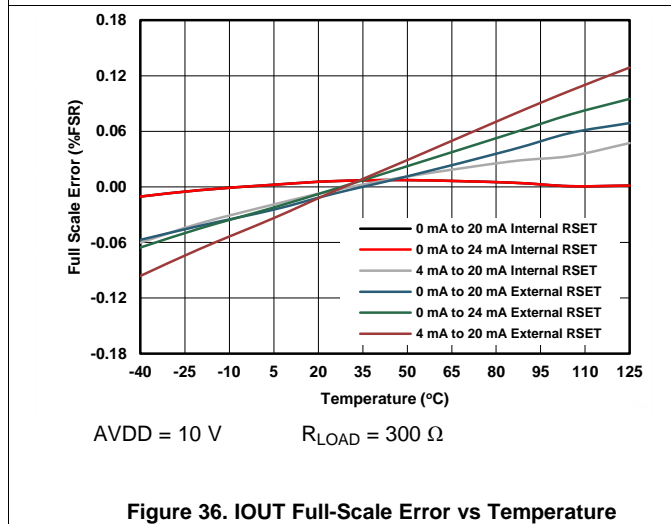

Figure 36. IOUT Full-Scale Error vs Temperature

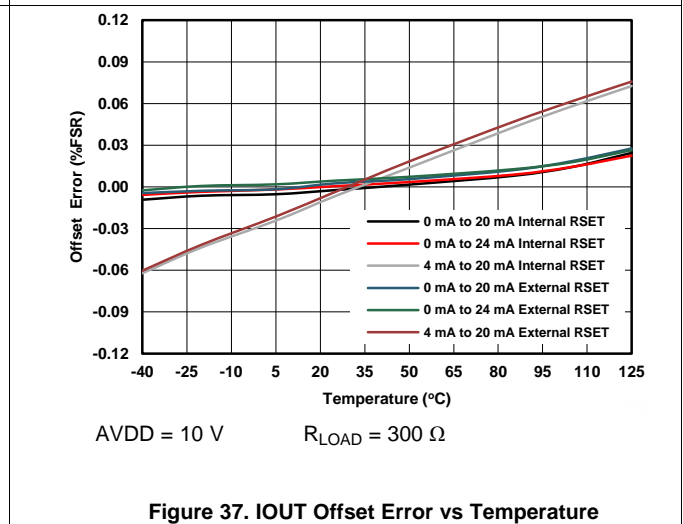

Figure 37. IOUT Offset Error vs Temperature

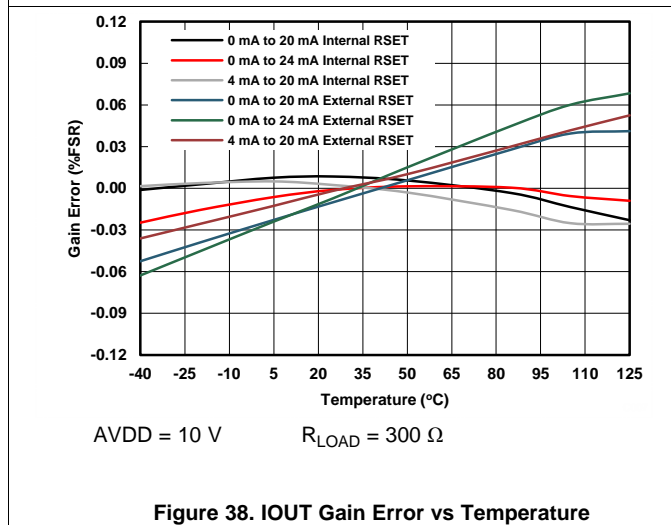

Figure 38. IOUT Gain Error vs Temperature

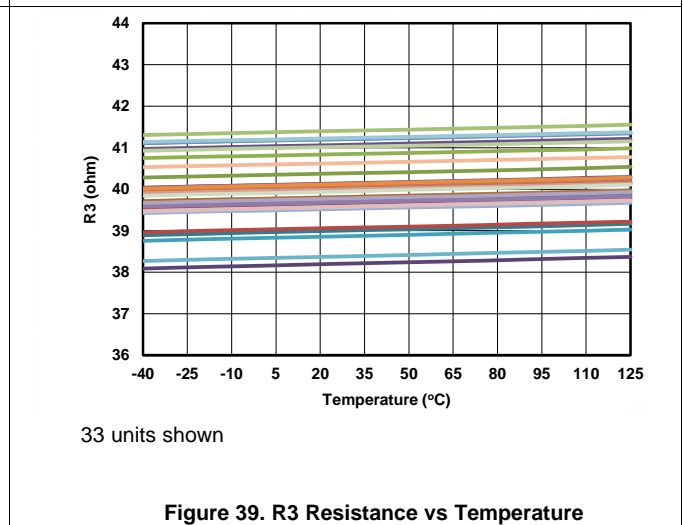

Figure 39. R3 Resistance vs Temperature

1. Compliance voltage headroom is defined as the drop from AVDD terminal to the IOUT terminal.

### Typical Characteristics (continued)

at  $T_A = 25^\circ\text{C}$  (unless otherwise noted)

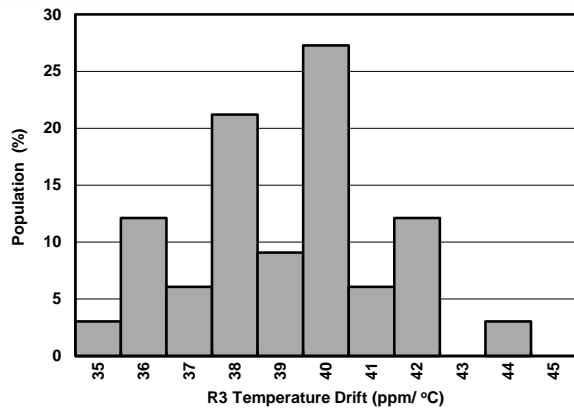
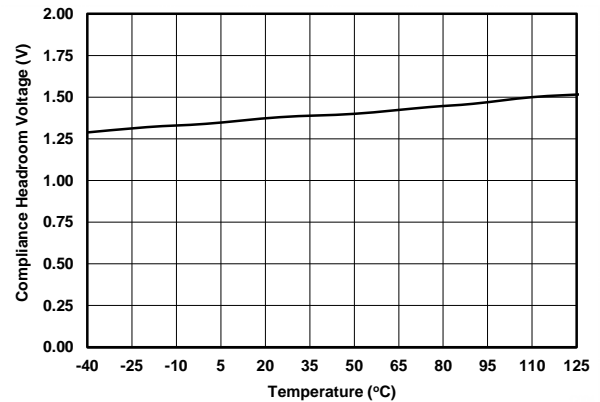
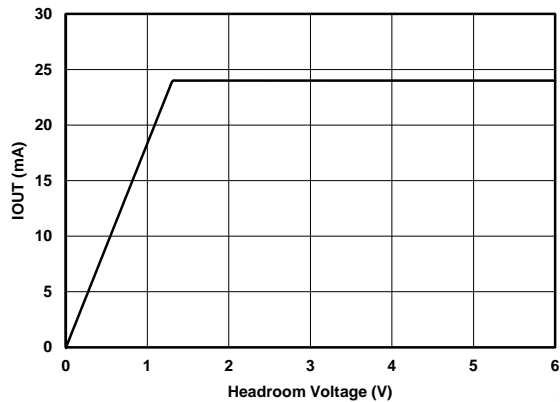

Figure 40. R3 Resistance Temperature Drift Histogram



AVDD = 36 V      IO<sub>UT</sub> = 24 mA      R<sub>LOAD</sub> = 300 Ω

Figure 41. Compliance Headroom Voltage<sup>(1)</sup> vs Temperature



AVDD = 36 V      DAC configured to deliver 24 mA  
R<sub>LOAD</sub> = 300 Ω

Figure 42. IO<sub>UT</sub> vs Compliance Headroom Voltage<sup>(1)</sup>

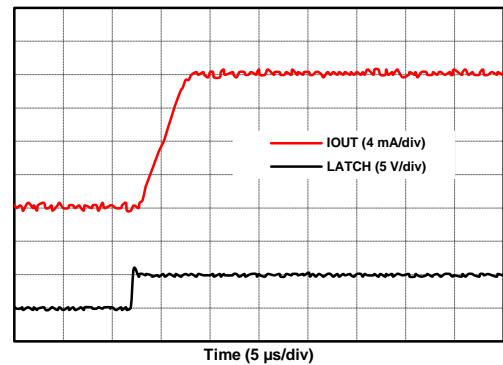

AVDD = 24 V      4-mA to 20-mA range  
R<sub>LOAD</sub> = 300 Ω      From code: 0x0000      To code: 0xFFFF

Figure 43. 4-mA to 20-mA Rising

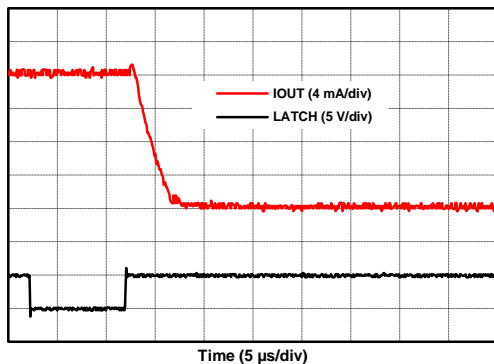

AVDD = 24 V      4-mA to 20-mA range  
R<sub>LOAD</sub> = 300 Ω      From code: 0x0000      To code: 0xFFFF

Figure 44. 4-mA to 20-mA Falling

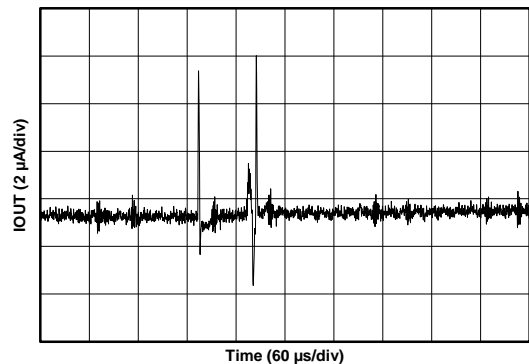

AVDD = 24 V      R<sub>LOAD</sub> = 300 Ω

Figure 45. IO<sub>UT</sub> Power-On Glitch

Typical Characteristics (continued)

at  $T_A = 25^\circ\text{C}$  (unless otherwise noted)

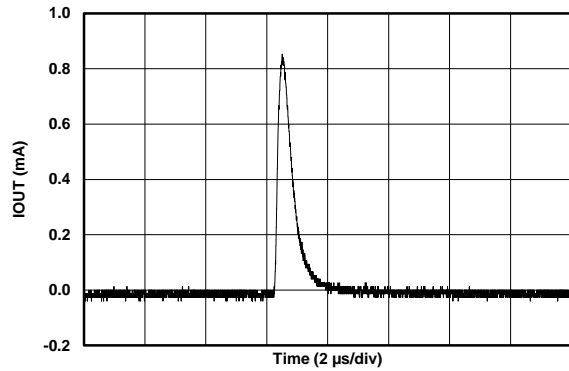

AVDD = 24 V  $R_{LOAD} = 300 \Omega$

Figure 46. IOUT Output Enable Glitch

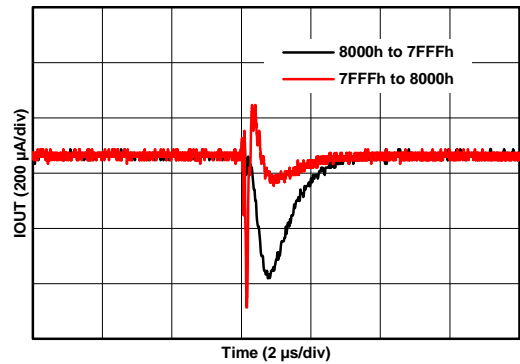

AVDD = 24 V  $R_{LOAD} = 250 \Omega$

Figure 47. IOUT Digital-to-Analog Glitch

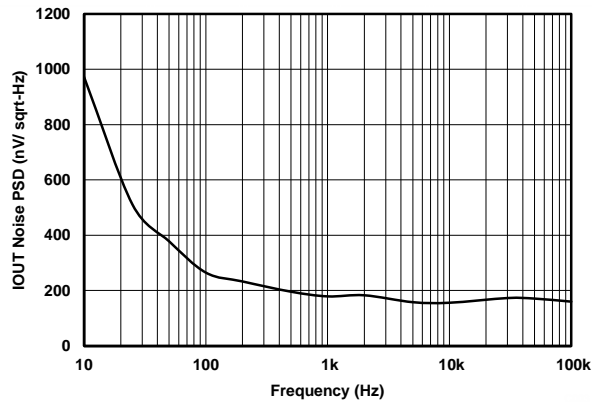

AVDD = 24 V  $R_{LOAD} = 300 \Omega$  All IOUT ranges

Figure 48. IOUT Noise PSD vs Frequency

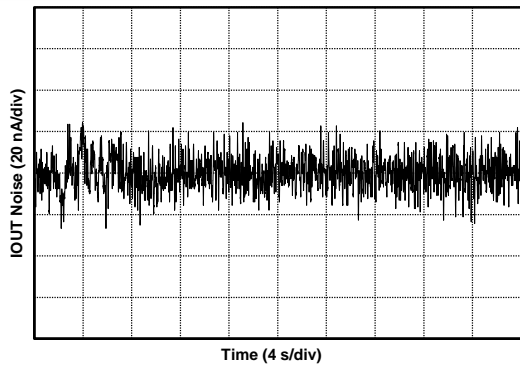

AVDD = 24 V 0-mA to 20-mA range  
DAC = midscale

Figure 49. IOUT Peak-to-Peak Noise vs Time (0.1 Hz to 10 Hz)

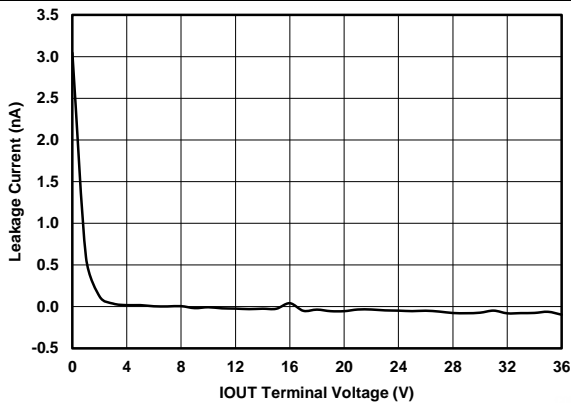

AVDD = 36 V Output disabled

Figure 50. IOUT Hi-Z Leakage Current vs Voltage

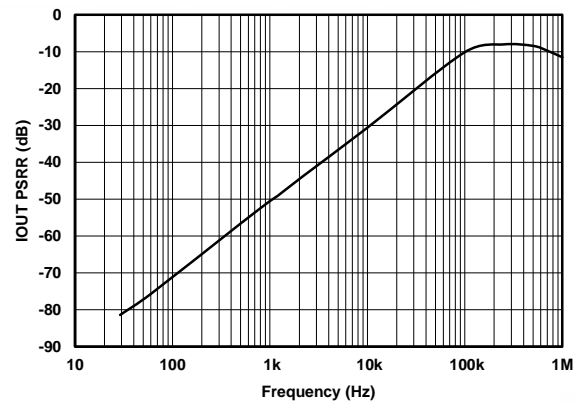

AVDD = 24 V  $R_{LOAD} = 250 \Omega$  All IOUT ranges

Figure 51. IOUT PSRR vs Frequency

## 8 Detailed Description

### 8.1 Overview

The DAC8750 and DAC7750 are low-cost, precision, fully-integrated, 16-bit and 12-bit digital-to-analog converters (DACs) designed to meet the requirements of industrial process control applications. These devices can be programmed as a current output with a range of 4 mA to 20 mA, 0 mA to 20 mA, or 0 mA to 24 mA. The DAC8750 and DAC7750 include reliability features such as CRC error checking on the serial peripheral interface (SPI) frame, a watchdog timer, an open circuit, compliance voltage, and thermal alarm. In addition the output current can be monitored by accessing an internal precision resistor.

These devices include a power-on-reset function to ensure powering up in a known state (both IOUT is disabled and in a high-impedance state). The CLR pin sets the current output to the low-end of the range if the output is enabled. Zero code error and gain error calibration registers can be programmed to digitally calibrate the device in the end system. The output slew rate is also programmable. These devices can AC couple an external HART signal on the current output and can operate with either a 10-V to 36-V supply.

### 8.2 Functional Block Diagram

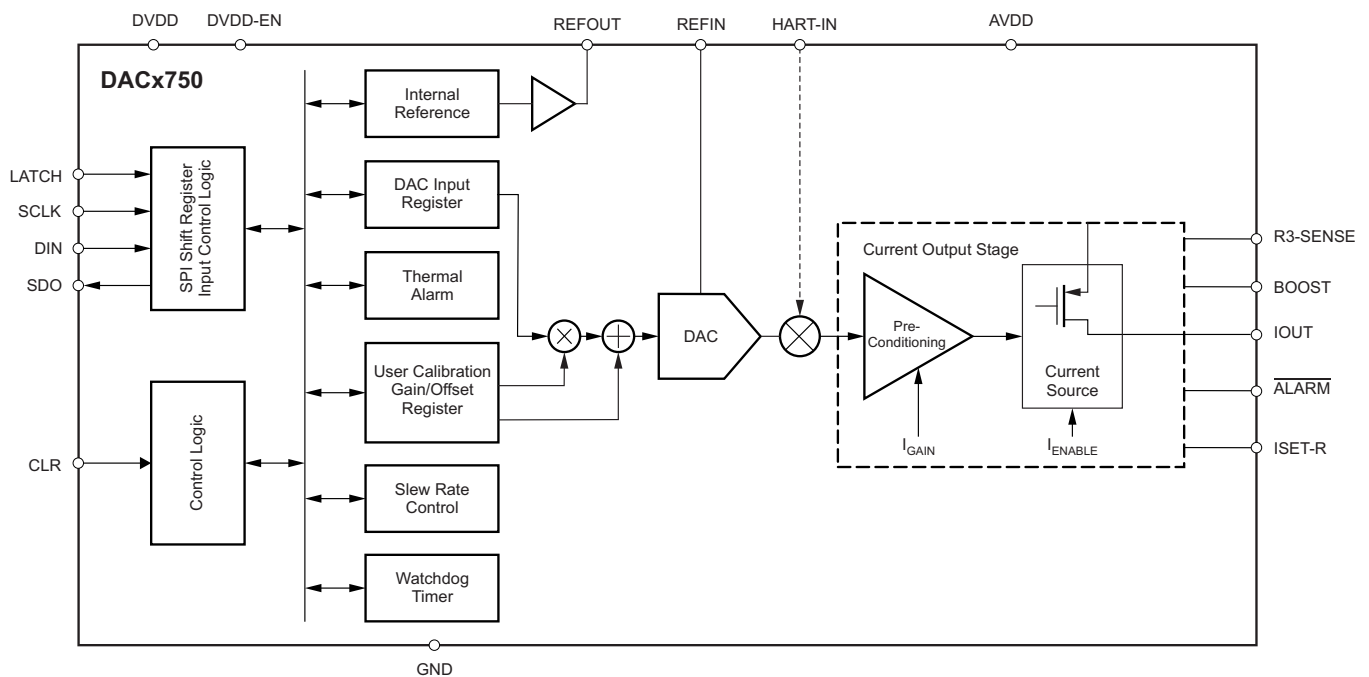

Copyright © 2016, Texas Instruments Incorporated

## 8.3 Feature Description

### 8.3.1 DAC Architecture

The resistor-string section is simply a string of resistors, each with the same value, from REFIN to GND, as [Figure 52](#) shows. This type of architecture makes sure the DAC is monotonic. The 16-bit (DAC8750) or 12-bit (DAC7750) binary digital code loaded to the DAC register determines at which node on the string the voltage is tapped off before it is fed into the voltage-to-current conversion stage. The current-output stage converts the voltage output from the string to current. When the output is disabled, it is in a high-impedance (Hi-Z) state. After power-on, the output is disabled.

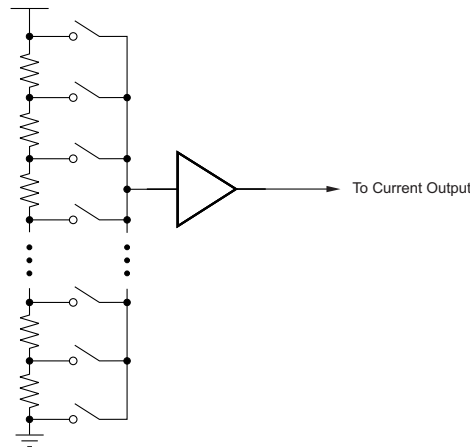

Figure 52. DAC Structure: Resistor String

### 8.3.2 Current Output Stage

The current output stage consists of a preconditioner and a current source, as shown in [Figure 53](#). This stage provides a current output according to the DAC code. The output range can be programmed as 0 mA to 20 mA, 0 mA to 24 mA, or 4 mA to 20 mA. Use an external transistor to reduce the power dissipation of the device. The maximum compliance voltage on IOUT equals  $(AVDD - 2\text{ V})$ . In single power-supply mode, the maximum AVDD is 36 V, and the maximum compliance voltage is 34 V. After power on, the IOUT terminal is in a Hi-Z state.

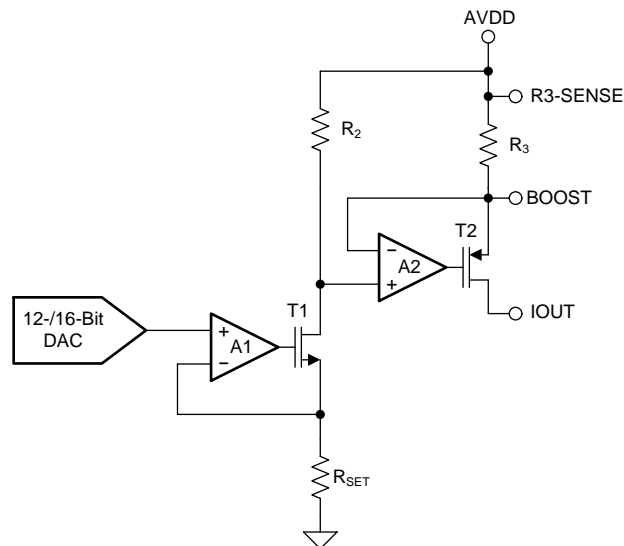

Figure 53. Current Output

## Feature Description (continued)

For a 5-V reference, the output can be expressed as shown in [Equation 1](#) through [Equation 3](#).

For a 0-mA to 20-mA output range, use [Equation 1](#).

$$I_{OUT} = 20\text{mA} \cdot \frac{CODE}{2^N} \quad (1)$$

For a 0-mA to 24-mA output range, use [Equation 2](#).

$$I_{OUT} = 24\text{mA} \cdot \frac{CODE}{2^N} \quad (2)$$

For a 4-mA to 20-mA output range, use [Equation 3](#).

$$I_{OUT} = 16\text{mA} \cdot \frac{CODE}{2^N} + 4\text{mA}$$

where

- *CODE* is the decimal equivalent of the code loaded to the DAC
  - *N* is the bits of resolution; 16 for DAC8750, and 12 for DAC7750
- (3)

The current-output range is normally set according to the value of the RANGE bits in the [Control Register](#) (see [Setting Current-Output Ranges](#) for more details).

### 8.3.3 Internal Reference

The DACx750 includes an integrated 5-V reference with a buffered output (REFOUT) capable of driving up to 5 mA (source or sink) with an initial accuracy of  $\pm 5$  mV maximum and a temperature drift coefficient of 10 ppm/°C maximum.

### 8.3.4 Digital Power Supply

An internally generated 4.6-V supply capable of driving up to 10 mA can be output on DVDD by leaving the DVDD-EN terminal unconnected. This eases the system power supply design when an isolation barrier is required to generate the digital supply. It can be used to drive isolation components used for the digital data lines and other miscellaneous components like references and temp sensors; see [Figure 62](#) for an example application.

If an external supply is preferred, the DVDD terminal (which can be driven up to 5.5 V in this case) can become an input by tying DVDD-EN to GND. See [Electrical Characteristics](#) for detailed specifications.

### 8.3.5 DAC Clear

The DAC has an asynchronous clear function through the CLR terminal that is active-high and allows the current output to be cleared to zero-scale code. When the CLR signal returns to low, the output remains at the cleared value. The preclear value can be restored by pulsing the LATCH signal without clocking any data. A new value cannot be programmed until the CLR terminal returns to low. To avoid glitches on the output, disable the output by writing a 0 to the OUTEN bit of the [Control Register](#) before changing the current range.

### 8.3.6 Power-Supply Sequence

The DACx750 has an internal power-on reset (POR) circuitry for both the digital DVDD and analog AVDD supplies. This circuitry makes sure that the internal logic and power-on state of the DAC power-up to the proper state independent of the supply sequence. The recommended power-supply sequence is to first have the analog AVDD supply come up, followed by the digital supply DVDD. DVDD can also come up first as long as AVDD ramps to at least 5 V within 50  $\mu$ s. If neither of these conditions can be satisfied, TI recommends that a software reset command be issued via the SPI bus after both AVDD and DVDD are stable.

## Feature Description (continued)

### 8.3.7 Power-On Reset

The DACx750 incorporates two internal POR circuits for the DVDD and AVDD supplies. The DVDD and AVDD POR signals are ANDed together so that both supplies must be at their minimal specified values for the device to *not* be in a reset condition. These POR circuits initialize internal logic and registers, as well as set the analog outputs to a known state while the device supplies are ramping. All registers are reset to their default values. Typically the POR function can be ignored, as long as the device supplies power-up and maintains the specified minimum voltage levels. However, in the case of a supply drop or brownout, the DACx750 can have an internal POR reset event or lose digital memory integrity. Figure 54 represents the threshold levels for the internal POR for both the DVDD and AVDD supplies.

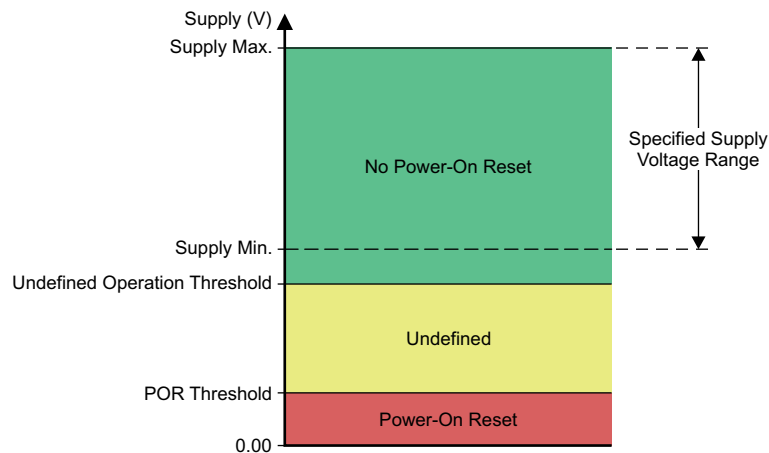

Figure 54. Relevant Voltage Levels for POR Circuit

For the DVDD supply, no internal POR occurs for nominal supply operation from 2.7 V (supply min) to 5.5 V (supply max). For the DVDD supply region between 2.4 V (undefined operation threshold) and 0.8 V (POR threshold), the internal POR circuit may or may not provide a reset over all temperature conditions. For the DVDD supply below 0.8 V (POR threshold), the internal POR resets if the supply voltage remains less than 0.8 V for approximately 1 ms.

For the AVDD supply, no internal POR occurs for nominal supply operation from 10 V (supply min) to 36 V (supply max). For AVDD supply voltages between 8 V (undefined operation threshold) and 1 V (POR threshold), the internal POR circuit may or may not provide a reset over all temperature conditions. For the AVDD supply below 1 V (POR threshold), the internal POR resets if the supply voltage remains less than 1 V for approximately 1 ms. In case the DVDD or AVDD supply drops to a level where the internal POR signal is indeterminate, either power cycle the device, or toggle the LATCH terminal and then perform a software reset. Both options initialize the internal circuitry to a known state and provide proper operation.

### 8.3.8 Alarm Detection

These devices also provide an alarm detection feature. When one or more of following events occur, the ALARM terminal goes low:

- The current output load is in open circuit,
- The voltage at IO<sub>UT</sub> reaches a level where accuracy of the output current is compromised. This condition is detected by monitoring internal voltage levels of the IO<sub>UT</sub> circuitry and is typically below the specified compliance voltage headroom (defined as the voltage drop between the AVDD and IO<sub>UT</sub> terminals) minimum of 2 V,
- The die temperature exceeds 142°C,
- The SPI watchdog timer exceeds the timeout period (if enabled), or
- The SPI frame error CRC check encounters an error (if enabled).

## Feature Description (continued)

When the  $\overline{\text{ALARM}}$  terminals of multiple DACx750 devices are connected together to form a wired-AND function, the host processor must read the status register of each device to know all the fault conditions that are present. Note that the thermal alarm has hysteresis of approximately 18°C. After being set, the alarm only resets when the die temperature drops below 124°C.

### 8.3.9 Watchdog Timer

This feature is useful to make sure that communication between the host processor and the DACx750 has not been lost. It can be enabled by setting the WDEN bit of the [Configuration Register](#) to 1. The watchdog timeout period can be set using the WDPD bits of the configuration register, as shown in [Table 1](#). The timer period is based off an internal oscillator with a typical value of 8 MHz.

**Table 1. Watchdog Timeout Period**

WDPD BITS	WATCHDOG TIMEOUT PERIOD (Typical)
00	10 ms
01	51 ms
10	102 ms
11	204 ms

If the watchdog timer is enabled, these devices must have an SPI frame with 0x95 as the write address byte written to the device within the programmed timeout period. Otherwise, the  $\overline{\text{ALARM}}$  terminal asserts low and the WD-FLT bit of the status register is set to 1. Note that the  $\overline{\text{ALARM}}$  terminal can be asserted low for any of the different conditions as explained in [Alarm Detection](#). The WD-FLT bit is reset to 0 with a software reset, by disabling the watchdog timer, or by powering down the device.

When using multiple DACx750 devices in a daisy-chain configuration, the open-drain  $\overline{\text{ALARM}}$  terminals of all devices can be connected together in a wired-AND function. The watchdog timer can be enabled in any number of the devices in the chain although enabling it in one device is sufficient. The wired-AND  $\overline{\text{ALARM}}$  terminal may get pulled low because of the simultaneous presence of different trigger conditions in the daisy-chained devices. The host processor reads the status register of each device to know all the fault conditions present in the chain.

#### 8.3.9.1 The DACx750 Shares the SPI Bus With Other Devices (Non-DACx750)

This section is only applicable for applications where the DACx750 is digitally interfaced via an SPI bus that has other devices on the bus that are not DACx750 devices.

As explained in the [Serial Peripheral Interface \(SPI\)](#) section of this document, the DACx750 digital interface constantly clocks in data regardless of the status of the LATCH pin, and data are unconditionally latched on the rising edge of the LATCH pin. A rising edge on the LATCH pin is the only way the device takes action on clocked data.

The watchdog timer can also be enabled without a rising edge on the LATCH pin if a specific pattern, shown in [Table 2](#), is present on DIN and SCLK. When this pattern enables the watchdog timer, this enabled status is not reflected in the configuration register. During this condition, the watchdog timer cannot be enabled or disabled through writes to the configuration register. Additionally, the alarm condition can only be cleared through a power-on reset event triggered either by a reset command or cycling power to the device. The ALARM pin also indicates that the watchdog timer has triggered.

**Table 2. Enable Watchdog Timer Digital Interface Pattern**

BIT FORMAT	BIT SETTING							
	DB23	DB22	DB21	DB20	DB19	DB18	DB17	DB16
Binary	0	0	1	0	1	0	1	1
Hex	0x2				0xB			
	DB25	DB14	DB13	DB12	DB11	DB10	DB9	DB8
Binary	1	X	X	X	X	X	X	X
Hex	D15 = 1				X			
	DB7	DB6	DB5	DB4	DB3	DB2	DB1	DB0
Binary	X	X	X	X	X	1	X	X
Hex	X				DB2 = 1			

If the watchdog timer feature is enabled as described in the [Watchdog Timer](#) section along with full compliance of the watchdog timer, then the pattern shown in [Table 2](#) on DIN and SCLK does not have any effect.

### 8.3.10 Frame Error Checking

In noisy environments, error checking can be used to check the integrity of SPI data communication between the DACx750 and the host processor. To enable this feature, set the CRCEN bit of the [Configuration Register](#) to 1. The frame error checking scheme is based on the CRC-8-ATM (HEC) polynomial  $x^8 + x^2 + x + 1$  (that is, 100000111). When error checking is enabled, the SPI frame width is 32 bits, as shown in [Table 3](#). Start with the default 24-bit frame, enable frame error checking, and then switch to the 32-bit frame. The normal 24-bit SPI data are appended with an 8-bit CRC polynomial by the host processor before feeding to the device. For a register readback, the CRC polynomial is output on the SDO terminals by the device as part of the 32-bit frame.

**Table 3. SPI Frame with Frame Error Checking Enabled**

BIT 31:BIT 8	BIT 7:BIT 0
Normal SPI frame data	8-bit CRC polynomial

When in CRC mode the DACx750 calculates CRC words every 32 clocks, unconditional of when the LATCH pin toggles. The DACx750 decodes the 32-bit input frame data to compute the CRC remainder. If no error exists in the frame, the CRC remainder is zero. When the remainder is non-zero (that is, the input frame has single- or multiple-bit errors), the ALARM terminal asserts low and the CRC-FLT bit of the status register is set to 1. The ALARM terminal can be asserted low for any of the different conditions as explained in [Alarm Detection](#). The CRC-FLT bit is reset to 0 with a software reset, by disabling the frame error checking, or by powering down the device. In the case of a CRC error, the specific SPI frame is blocked from writing to the device.

Frame error checking can be enabled for any number of DACx750 devices connected in a daisy-chain configuration. However, it is recommended to enable error checking for either none or all devices in the chain. When connecting the ALARM terminals of multiple devices, forming a wired-AND function, the host processor reads the status register of each device to know all the fault conditions present in the chain. For proper operation, the host processor must provide the correct number of SCLK cycles in each frame, taking care to identify whether or not error checking is enabled in each device in the daisy-chain.

If the CRC mode is enabled on the first frame issued to the device after power-up, TI suggests that a no operation, or NOOP, command be issued to the device in order to reset the SPI clock and SPI frame alignment in the event that any transients on the SCLK line are interpreted as SCLK periods. A NOOP command can be issued to the device by simply toggling the LATCH pin without any SCLK periods.

### 8.3.10.1 The DACx750 Shares the SPI Bus With Other Devices (Non-DACx750)

This section is only applicable for applications where the DACx750 is digitally interfaced via an SPI bus that has other devices on the bus that are not DACx750 devices, and there are multiple DACx750s in a daisy-chain configuration.

As explained in the [SPI Shift Register](#) section of this document, the DACx750 digital interface constantly clocks in data regardless of the status of the LATCH pin, and data are unconditionally latched on the rising edge of the LATCH pin. A rising edge on the LATCH pin is the only way the device takes action on clocked data.

The frame error checking (CRC) mode can also be enabled without a rising edge on the LATCH pin if a specific pattern, shown in [Table 4](#), is present on DIN and SCLK. When this pattern enables CRC mode, this enabled status is not reflected in the configuration register. During this condition the CRC mode cannot be enabled or disabled through writes to the configuration register. Additionally, the alarm pin and status registers do not indicate CRC alarm conditions, and frames with incorrect or missing CRC bits are not disregarded as described in the [Frame Error Checking](#) section. During this condition the devices in daisy-chain output data on the SDO pin on a 32-bit frame structure instead of 24 bits. The CRC mode can only be cleared through a power-on reset event triggered either by a reset command or by cycling power to the device.

**Table 4. Enable CRC Mode Digital Interface Pattern**

BIT FORMAT	BIT SETTING							
	DB23	DB22	DB21	DB20	DB19	DB18	DB17	DB16
Binary	0	1	0	1	0	1	1	1
Hex	0x5				0x7			
	DB15	DB14	DB13	DB12	DB11	DB10	DB9	DB8
Binary	X	X	X	X	X	X	1	1
Hex	X				X			
	DB7	DB6	DB5	DB4	DB3	DB2	DB1	DB0
Binary	0	0	1	0	1	0	1	1
Hex	X				DB2 = 1			

If the CRC feature is enabled as described in the [Frame Error Checking](#) section along with full compliance of the frame error checking, then the pattern shown in [Table 4](#) on DIN and SCLK does not have any effect.

### 8.3.11 User Calibration

The device implements a user-calibration function (enabled by the CALEN bit in the [Configuration Register](#)) to trim system gain and zero errors. The DAC output is calibrated according to the value of the gain calibration and zero calibration registers. The range of gain adjustment is typically  $\pm 50\%$  of full-scale with 1 LSB per step. The gain register must be programmed to 0x8000 to achieve the default gain of 1 because the power-on value of the register is 0x0000, equivalent to a gain of 0.5. The zero code adjustment is typically  $\pm 32,768$  LSBs with 1 LSB per step. The input data format of the gain register is unsigned straight binary, and the input data format of the zero register is twos complement. The gain and offset calibration is described by [Equation 4](#).

$$\text{CODE\_OUT} = \text{CODE} \cdot \frac{\text{User\_GAIN} + 2^{15}}{2^{16}} + \text{User\_ZERO}$$

where

- *CODE* is the decimal equivalent of the code loaded to the DAC data register at address 0x01
  - *N* is the bits of resolution (16 for DAC8750 and 12 for DAC7750)
  - *User\_ZERO* is the signed 16-bit code in the zero register
  - *User\_GAIN* is the unsigned 16-bit code in the gain register
  - *CODE\_OUT* is the decimal equivalent of the code loaded to the DAC (limited between 0x0000 to 0xFFFF for DAC8750 and 0x000 to 0xFFF for DAC7750)
- (4)

This is a purely digital implementation and the output is still limited by the programmed value at both ends of the current output range (set by the RANGE bits, as described in [Setting Current-Output Ranges](#)). In addition, the correction only makes sense for endpoints inside of the true device end points. To correct more than just the actual device error, for example a system offset, the valid range for the adjustment changes accordingly and must be taken into account.

New calibration codes are only applied to subsequent writes to the DAC data register. Updating the calibration codes does not automatically update the DAC output. Additionally, TI recommends configuring the calibration codes along with the slew rate control prior to applying new DAC data.

### 8.3.12 Programmable Slew Rate

The slew rate control feature controls the rate at which the output current changes. With the slew rate control feature disabled, the output changes smoothly at a rate limited by the output drive circuitry and the attached load.

To reduce the slew rate, enable the slew rate control feature through bit 4 of the [Control Register](#). With this feature enabled, the output does not slew directly between the two values. Instead, the output steps digitally at a rate defined by bits [7:5] (SRSTEP) and bits [11:8] (SRCLK) of the [Control Register](#). SRCLK defines the rate at which the digital slew updates; SRSTEP defines the amount by which the output value changes at each update. If the DAC data register is read while the DAC output is still changing, the instantaneous value is read. [Table 5](#) lists the slew rate step-size options. [Table 6](#) summarizes the slew rate update clock options.

**Table 5. Slew Rate Step-Size (SRSTEP) Options**

SRSTEP	STEP SIZE (LSB)	
	DAC7750	DAC8750
000	0.0625	1
001	0.125	2
010	0.125	4
011	0.5	8
100	1	16
101	2	32
110	4	64
111	8	128

**Table 6. Slew Rate Update Clock (SRCLK) Options**

SRCLK	DAC UPDATE FREQUENCY (Hz)
0000	258,065
0001	200,000
0010	153,845
0011	131,145
0100	115,940
0101	69,565
0110	37,560
0111	25,805
1000	20,150
1001	16,030
1010	10,295
1011	8,280
1100	6,900
1101	5,530
1110	4,240
1111	3,300

The time required for the output to slew over a given range is expressed as [Equation 5](#).

$$\text{Slew Time} = \frac{\text{Output Change}}{\text{Step Size} \cdot \text{Update Clock Frequency} \cdot \text{LSB Size}}$$

where

- *Slew Time* is expressed in seconds
- *Output Change* is expressed in amps (A) for IOOUT or volts (V) for VOUT (5)

When the slew rate control feature is enabled, all output changes happen at the programmed slew rate. This configuration results in a staircase formation at the output. If the CLR terminal is asserted, the output slews to the zero-scale value at the programmed slew rate. Bit 1 (SR-ON) of the [Status Register](#) can be read to verify that the slew operation has completed. The update clock frequency for any given value is the same for all output ranges. The step size, however, varies across output ranges for a given value of step size because the LSB size is different for each output range. [Figure 55](#) shows an example of IOOUT slewing at a rate set by the above described parameters. In this example for the DAC8750 (LSB size of 305 nA for the 0-mA to 20-mA range), the settings correspond to an update clock frequency of 6.9 kHz and a step size of 128 LSB. As is shown in the case with no capacitors on CAP1 or CAP2, the steps occur at the update clock frequency (6.9 kHz corresponds to a period close to 150 μs), and the size of each step is approximately 38 μA (128 × 305 nA). Calculate the slew time for a specific code change by using [Equation 5](#).

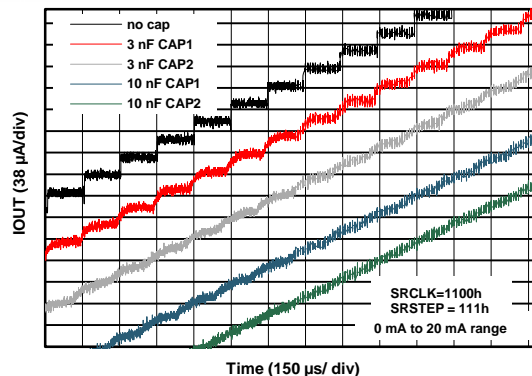

**Figure 55. IOOUT vs Time with Digital Slew Rate Control**

Apply the desired programmable slew rate control setting prior to updating the DAC data register because updates to the DAC data register in tandem with updates to the slew rate control registers can create race conditions that may result in unexpected DAC data.

## 8.4 Device Functional Modes

### 8.4.1 Setting Current-Output Ranges

The current output range is set according to [Table 7](#).

**Table 7. RANGE Bits vs Output Range**

RANGE	OUTPUT RANGE
101	4 mA to 20 mA
110	0 mA to 20 mA
111	0 mA to 24 mA

Note that changing the RANGE bits at any time causes the DAC data register to be cleared.

### 8.4.2 Current-Setting Resistor

Resistor  $R_{SET}$  (used to convert the DAC voltage to current) illustrated in [Figure 53](#) determines the stability of the output current over temperature. If desired, an external, low-drift, precision 15-k $\Omega$  resistor can be connected to the ISET-R terminal and used instead of the internal  $R_{SET}$  resistor.

### 8.4.3 BOOST Configuration for IOU

[Figure 56](#) illustrates an external NPN transistor used to reduce power dissipation on the die. Most of the load current flows through the NPN transistor with a small amount flowing through the on-chip PMOS transistor based on the gain of the NPN transistor. This configuration reduces the temperature induced drift on the die and internal reference and is an option for use cases at the extreme end of the supply, load current, and ambient temperature ranges.

The inclusion of the bipolar junction transistor (BJT) adds an additional open loop gain to internal amplifier A2 (see [Figure 53](#)) and thus, can cause possible instability. Adding series emitter resistor R2 decreases the gain of the stage created by the BJT and internal R3 resistor (see [Figure 53](#)) especially for cases where  $R_{LOAD}$  is a short or a very small load, such as a multimeter. Recommended values for  $R_1$ ,  $R_2$ , and  $C_1$  in this circuit are 1 k $\Omega$ , 30  $\Omega$  and 22 nF, respectively. An equivalent solution is to place  $R_2$  (with a recommended value of 3 k $\Omega$  instead of 30  $\Omega$ ) in series with the base of the transistor instead of the configuration provided in [Figure 56](#). Note that there is some gain error introduced by this configuration; see [Figure 15](#), [Figure 16](#) and [Figure 17](#). Use the internal transistor in most cases because the values in [Electrical Characteristics](#) are based on the configuration with the internal on-chip PMOS transistor.

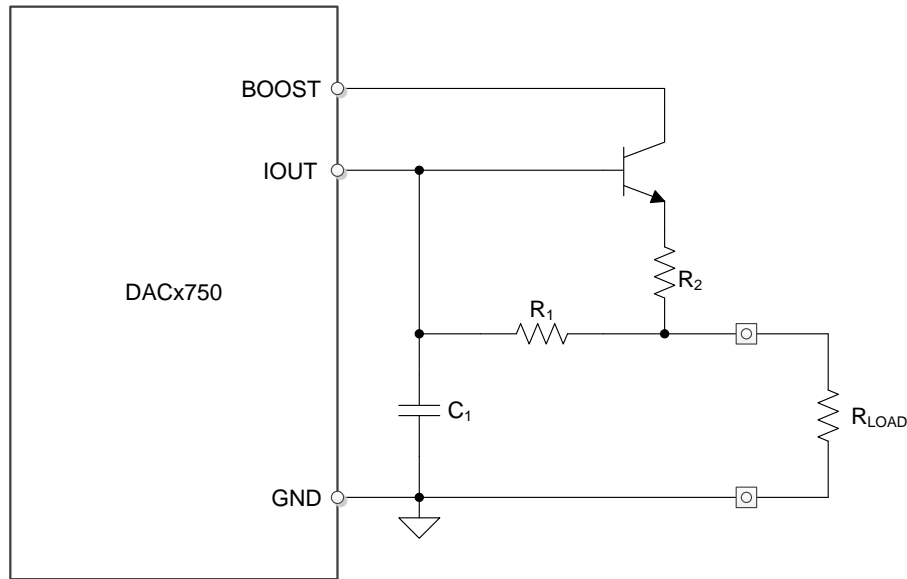

Copyright © 2016, Texas Instruments Incorporated

Figure 56. Boost Mode Configuration

### 8.4.4 Filtering The Current Output

The DACx750 provides access to internal nodes of the circuit; see Figure 61. Place capacitors on these terminals and AVDD to form a filter on the output current, reducing bandwidth and the slew rate of the output, especially useful for driving inductive loads. However, to achieve large reductions in slew rate, use the programmable slew rate to avoid having to use large capacitors. Even in that case, use the capacitors on CAP1 and CAP2 to smooth out the stairsteps caused by the digital code changes as shown in Figure 57. However, note that power supply ripple also couples into the devices through these capacitors.

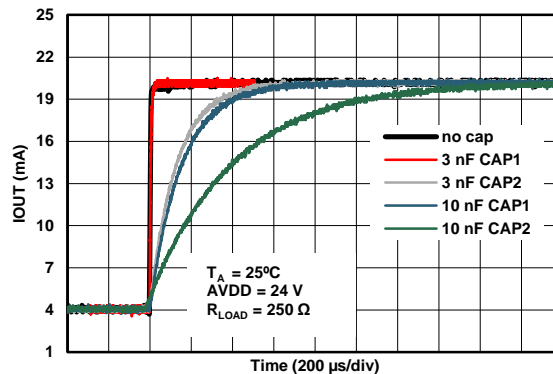

Figure 57. IOUT vs Time for Different Cap Values on CAP1 and CAP2

### 8.4.5 Output Current Monitoring

Many applications, especially for functional safety, require monitoring of the output current to ensure it stays close to the programmed value. Place a sense resistor in series to the output to measure the voltage across it. However, this resistor reduces the compliance voltage available for the load. The DACx750 provides access to an internal precision resistor (R3 in Figure 53) through the R3-SENSE and BOOST terminals to perform analog readback for monitoring the output current. Measure the voltage between the R3-SENSE and BOOST terminals and divide by the value of the R3 resistor to determine the magnitude of the output current. The R3 resistor has a typical value of 40 Ω (see Figure 39 for a plot of resistance versus temperature) with a temperature drift

coefficient of 40 ppm/°C (see [Figure 40](#) for a histogram of R3 resistance temperature drift). The R3 resistor is tested to stay within the minimum (36 Ω) and maximum (44 Ω) resistance values shown in the *R3 Resistor* section of [Electrical Characteristics](#). To remove the tolerance error, perform a simple calibration by programming a certain value of output current, measuring the voltage across R3-SENSE and BOOST, and calculating the exact value of R3.

### 8.4.6 HART Interface

On the DACx750, HART digital communication can be modulated onto the input signal by the methods shown in the following subsections. For more detail, see [Implementing HART Communication with the DAC8760 Family](#).

#### 8.4.6.1 Implementing HART in 4-mA to 20-mA Mode

This method is limited to the case where the RANGE bits of the [Control Register](#) are programmed to the 4-mA to 20-mA range. Some applications require going beyond the 4-mA to 20-mA range. In those cases, refer to the methods described in the next subsection.

The external HART signal (ac voltage; 500 mV<sub>PP</sub>, 1200 Hz, and 2200 Hz) can be capacitively coupled in through the HART-IN terminal and transferred to a current that is superimposed on the 4-mA to 20-mA current output. The HART-IN terminal has a typical input impedance of 35 kΩ that together with the input capacitor used to couple the external HART signal, forms a filter to attenuate frequencies beyond the HART band-pass region. In addition to this filter, an external passive filter is recommended to complete the filtering requirements of the HART specifications. [Figure 58](#) shows the output current versus time operation for a typical HART signal. [Table 8](#) specifies the performance of the HART-IN terminal.

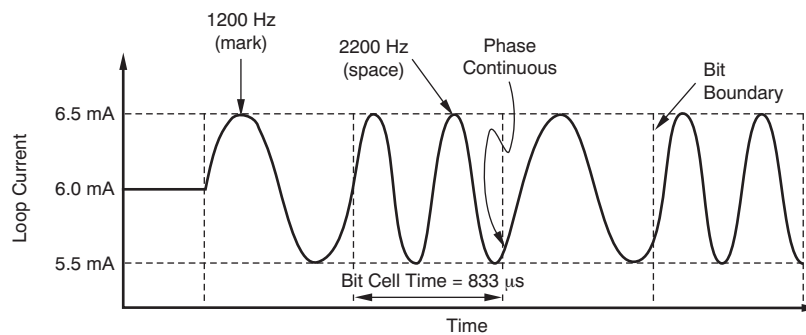

NOTE: DC current = 6 mA.

Figure 58. Output Current vs Time

Table 8. HART-IN Terminal Characteristics

PARAMETER	TEST CONDITIONS	MIN	TYP	MAX	UNIT
Input impedance	HART signal ac-coupled into terminal		35		kΩ
Output current (peak-to-peak)	Input signal of 500 mV (peak-to-peak)	0.9	1	1.1	mA

#### 8.4.6.2 Implementing HART in All Current Output Modes

The use of the HART-IN terminal to implement HART modulation is limited to the case where the RANGE bits of the [Control Register](#) are set to the 4-mA to 20-mA range. If it is desirable to implement HART in all current-output modes, refer to [Implementing HART In All Current Output Modes](#) in [Application Information](#).

## 8.5 Programming

[Table 13](#) describes the available commands and registers on the DACx750 devices. *No operation*, *read operation*, and *watchdog timer* refer to commands and are not explicit registers. For more information on these commands, see the [Read Operation](#) and [Watchdog Timer](#) sections.

## Programming (continued)

### 8.5.1 Serial Peripheral Interface (SPI)

The device is controlled over a versatile four-wire serial interface (SDI, SDO, SCLK, and LATCH) that operates at clock rates of up to 30 MHz and is compatible with SPI, QSPI™, Microwire, and digital signal processing (DSP) standards. The SPI communication command consists of a write address byte and a data word for a total of 24 bits. The timing for the digital interface is illustrated in [Figure 1](#), [Figure 2](#), and [Figure 3](#).

#### 8.5.1.1 SPI Shift Register

The default frame is 24 bits wide (see [Frame Error Checking](#) for 32-bit frame mode) and begins with the rising edge of SCLK that clocks in the MSB. The subsequent bits are latched on successive rising edges of SCLK. The default 24-bit input frame consists of an 8-bit address byte followed by a 16-bit data word as shown in [Table 9](#).

**Table 9. Default SPI Frame**

BIT 23:BIT 16	BIT 15:BIT 0
Address byte	Data word

The host processor must issue 24 bits before it issues a rising edge on the LATCH terminal. Input data bits are clocked in regardless of the LATCH terminal and are unconditionally latched on the rising edge of LATCH. By default, the SPI shift register resets to 0x000000 at power on or after a reset.

#### 8.5.1.2 Write Operation

A write operation is accomplished when the address byte is set according to [Table 10](#). For more information on the DACx750 registers, see the [Register Maps](#) section.

**Table 10. Write Address Functions**

ADDRESS BYTE (HEX)	FUNCTION
00	No operation (NOP)
01	Write DAC Data register
02	Register read
55	Write control register
56	Write reset register
57	Write configuration register
58	Write DAC gain calibration register
59	Write DAC zero calibration register
95	Watchdog timer reset

#### 8.5.1.3 Read Operation

A read operation is accomplished when the address byte is 0x02. Follow the read operation with a no-operation (NOP) command to clock out an addressed register; see [Figure 2](#). To read from a register, the address byte and data word is as shown in [Table 11](#). The read register value is output MSB first on SDO on successive falling edges of SCLK.

**Table 11. Default SPI Frame for Register Read**

ADDRESS BYTE (HEX)	DATA WORD	
	BIT 15:BIT 6	BIT 5:BIT 0
02	X ( <i>don't care</i> )	Register read address (see <a href="#">Table 12</a> )

Table 12 shows the register read addresses available on the DACx750 devices.

**Table 12. Register Read Address Functions**

READ ADDRESS <sup>(1)</sup>	FUNCTION
XX XX00	Read status register
XX XX01	Read DAC data register
XX XX10	Read control register
00 1011	Read configuration register
01 0011	Read DAC gain calibration register
01 0111	Read DAC zero calibration register

(1) X denotes *don't care* bits.

#### 8.5.1.4 Stand-Alone Operation

SCLK can operate in either continuous or burst mode, as long as the LATCH rising edge occurs after the appropriate number of SCLK cycles. Providing more than or less than 24 SCLK cycles before the rising edge of LATCH results in incorrect data being programmed into the device registers, and incorrect data sent out on SDO. The rising edge of SCLK that clocks in the MSB of the 24-bit input frame marks the beginning of the write cycle, and data are written to the addressed registers on the rising edge of LATCH.

#### 8.5.1.5 Daisy-Chain Operation

For systems that contain multiple DACx750s, use the SDO terminal to daisy-chain several devices. This mode is useful in reducing the number of serial interface lines in applications that use multiple SPI devices. Daisy-chain mode is enabled by setting the DCEN bit of the control register to 1. By connecting the SDO of the first device to the SDI input of the next device in the chain, a multiple-device interface is constructed, as Figure 59 shows.

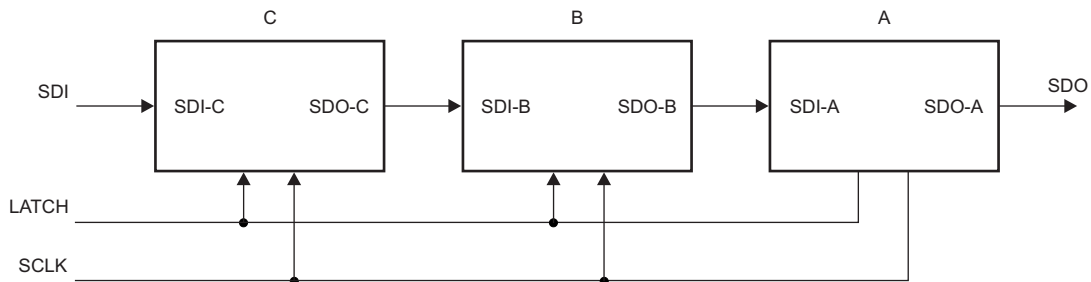

**Figure 59. Three DACx750s in Daisy-Chain Mode**

Like stand-alone operation, the SPI daisy-chain write operation requires one frame, and the read requires two frames. The rising edge of SCLK that clocks in the MSB of the input frame marks the beginning of the write cycle. When the serial transfer to all devices is complete, LATCH is taken high. This action transfers the data from the SPI shift registers to the device internal register of each DACx750 in the daisy-chain. However, the number of clocks in each frame in this case depends on the number of devices in the daisy chain. For two devices, each frame is 48 clocks; the first 24 clocks are for the second DAC and the next 24 bits are for the first DAC. For a readback, the data are read from the two DACs in the following 48-bit frame; the first 24 clocks are for the second DAC, and the next 24 clocks are for the first DAC. The input data to the DACs during the second frame can be another command or NOP. Similar to the two-device case described, for N devices, each frame is  $N \times 24$  clocks, where N is the total number of DACx750s in the chain.

The serial clock can be a continuous or gated clock. A continuous SCLK source can only be used if LATCH is taken high after the correct number of clock cycles. In gated clock mode, a burst clock containing the exact number of clock cycles must be used, and LATCH must be taken high after the final clock to latch the data.

## 8.6 Register Maps

Table 13 shows the available registers on the DACx750 devices. See [DACx750 Register Descriptions](#) for descriptions of all DACx750 registers.

**Table 13. Command and Register Map**

REGISTER OR COMMAND	READ AND WRITE ACCESS	DATA BITS (DB15:DB0)													
		15:14	13	12	11	10:9	8	7	6	5	4	3	2	1	0
<i>Control</i>	RW	X	REXT	OUTEN	SRCLK			SRSTEP			SREN	DCEN	RANGE		
<i>Configuration</i>	RW	X <sup>(1)</sup>						CALEN	HARTEN	CRCEN	WDEN	WDPD			
<i>DAC Data</i> <sup>(2)</sup>	RW	D15:D0													
<i>No operation</i> <sup>(3)</sup>	—	X													
<i>Read Operation</i> <sup>(3)</sup>	—	X						READ ADDRESS							
<i>Reset</i>	W												RESET		
<i>Status</i>	R	Reserved									CRC-FLT	WD-FLT	I-FLT	SR-ON	T-FLT
<i>DAC Gain Calibration</i> <sup>(2)</sup>	RW	G15:G0, unsigned													
<i>DAC Zero Calibration</i> <sup>(2)</sup>	RW	Z15:Z0, signed													
<i>Watchdog Timer</i> <sup>(3)</sup>	—	X													

(1) X denotes *don't care* bits.

(2) DAC8750 (16-bit version) shown. DAC7750 (12-bit version) contents are located in DB15:DB4. For DAC7750, DB3:DB0 are *don't care* bits when writing and zeros when reading.

(3) *No operation*, *read operation*, and *watchdog timer* are commands and not registers.

### 8.6.1 DACx750 Register Descriptions

#### 8.6.1.1 Control Register

The DACx750 control register is written to at address 0x55. Table 14 shows the description for the control register bits.

**Table 14. Control Register**

DATA BIT(S)	NAME	DEFAULT	DESCRIPTION
DB15:DB14	Reserved	00	Reserved. Do not write any value other than zero to these bits.
DB13	REXT	0	External current setting resistor enable.
DB12	OUTEN	0	Output enable. Bit = 1: Output is determined by RANGE bits. Bit = 0: Output is disabled. IOU is Hi-Z.
DB11:DB8	SRCLK[3:0]	0000	Slew rate clock control. Ignored when bit SREN = 0.
DB7:DB5	SRSTEP[2:0]	000	Slew rate step size control. Ignored when bit SREN = 0.
DB4	SREN	0	Slew Rate Enable. Bit = 1: Slew rate control is enabled, and the ramp speed of the output change is determined by SRCLK and SRSTEP. Bit = 0: Slew rate control is disabled. Bits SRCLK and SRSTEP are ignored. The output changes to the new level immediately.
DB3	DCEN	0	Daisy-chain enable.
DB2:DB0	RANGE[2:0]	000	Output range bits.

### 8.6.1.2 Configuration Register

The DACx750 configuration register is written to at address 0x57. [Table 15](#) summarizes the description for the configuration register bits.

**Table 15. Configuration Register**

DATA BIT(S)	NAME	DEFAULT	DESCRIPTION
DB15:DB6	Reserved	00 0000 0000	Reserved. Do not write any value other than zero to these bits.
DB5	CALEN	0	User calibration enable. When user calibration is enabled, the DAC data are adjusted according to the contents of the gain and zero calibration registers. See the <a href="#">User Calibration</a> section.
DB4	HARTEN	0	Enable interface through HART-IN terminal (only valid for IOOUT set to 4-mA to 20-mA range through RANGE bits). Bit = 1: HART signal is connected through internal resistor and modulates output current. Bit = 0: HART interface is disabled.
DB3	CRCEN	0	Enable frame error checking.
DB2	WDEN	0	Watchdog timer enable.
DB1:DB0	WDPD[1:0]	00	Watchdog timeout period.

### 8.6.1.3 DAC Registers

The DAC registers consist of a DAC data register ([Table 16](#)), a DAC gain calibration register ([Table 17](#)), and a DAC zero calibration register ([Table 18](#)). User calibration as described in the [User Calibration](#) section is a feature that allows for trimming the system gain and zero errors. [Table 16](#) through [Table 18](#) show the DAC8750, 16-bit version of these registers. The DAC7750 (12-bit version) register contents are located in DB15:DB4. For DAC7750, DB3:DB0 are *don't care* bits when writing and zeros when reading.

**Table 16. DAC Data Register**

DATA BITS	NAME	DEFAULT	DESCRIPTION
DB15:DB0	D15:D0	0x0000	DAC data register. Format is unsigned straight binary.

**Table 17. DAC Gain Calibration Register**

DATA BITS	NAME	DEFAULT	DESCRIPTION
DB15:DB0	G15:G0	0x0000	Gain calibration register for user calibration. Format is unsigned straight binary.

**Table 18. DAC Zero Calibration Register**

DATA BITS	NAME	DEFAULT	DESCRIPTION
DB15:DB0	Z15:Z0	0x0000	Zero calibration register for user calibration. Format is twos complement.

### 8.6.1.4 Reset Register

The DACx750 reset register is written to at address 0x56. [Table 19](#) provides the description.

**Table 19. Reset Register**

DATA BIT(S)	NAME	DEFAULT	DESCRIPTION
DB15:DB1	Reserved	000 0000 0000 0000	Reserved. Writing to these bits does not cause any change.
DB0	RESET	0	Software reset bit. Writing 1 to the bit performs a software reset that resets all registers and the ALARM status to the respective power-on reset default value. After reset completes, the RESET bit clears itself.

### 8.6.1.5 Status Register

This read-only register consists of four  $\overline{\text{ALARM}}$  status bits (CRC-FLT, WD-FLT, I-FLT, and T-FLT) and the SR-ON bit that shows the slew rate status, as shown in [Table 20](#).

**Table 20. Status Register**

DATA BIT(S)	NAME	DEFAULT	DESCRIPTION
DB15:DB5	Reserved	000 0000 0000	Reserved. Reading these bits returns 0.
DB4	CRC-FLT	0	Bit = 1 indicates CRC error on SPI frame. Bit = 0 indicates normal operation.
DB3	WD-FLT	0	Bit = 1 indicates watchdog timer timeout. Bit = 0 indicates normal operation.
DB2	I-FLT	0	Bit = 1 indicates an open circuit or a compliance voltage violation in IOUT loading. Bit = 0 indicates IOUT load is at normal condition.
DB1	SR-ON	0	Bit = 1 when DAC code is slewing as determined by SRCLK and SRSTEP. Bit = 0 when DAC code is not slewing.
DB0	T-FLT	0	Bit = 1 indicates die temperature is over 142°C. Bit = 0 indicates die temperature is not over 142°C.

These devices continuously monitor the current output and die temperature. When an alarm occurs, the corresponding  $\overline{\text{ALARM}}$  status bit is set (1). Whenever an  $\overline{\text{ALARM}}$  status bit is set, it remains set until the event that caused it is resolved. The  $\overline{\text{ALARM}}$  bit can only be cleared by performing a software reset, a power-on reset (by cycling power), or by having the error condition resolved. These bits are reasserted if the alarm condition continues to exist in the next monitoring cycle.

The  $\overline{\text{ALARM}}$  bit goes to 0 when the error condition is resolved.

## 9 Application and Implementation

### NOTE

Information in the following applications sections is not part of the TI component specification, and TI does not warrant its accuracy or completeness. TI's customers are responsible for determining suitability of components for their purposes. Customers should validate and test their design implementation to confirm system functionality.

### 9.1 Application Information

#### 9.1.1 Implementing HART in All Current Output Modes

If it is desirable to implement HART irrespective of the RANGE bit settings, there are two ways to do this.

##### 9.1.1.1 Using CAP2 Terminal

The first method of implementing HART is to couple the signal through the CAP2 pin, as shown in Figure 60. Note that this pin is only available in the 40-pin VQFN package

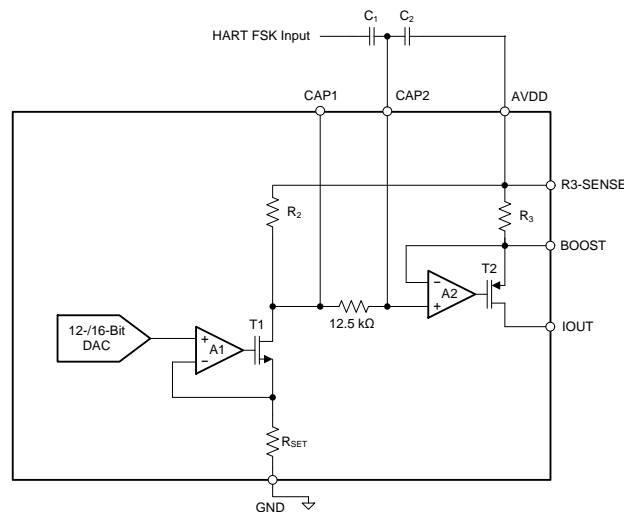

Figure 60. Implementing HART on IOOUT Using the CAP2 Terminal

In Figure 60,  $R_3$  is nominally 40  $\Omega$ , and  $R_2$  is dependent on the current output range (set by the RANGE bits), described as follows:

- 4-mA to 20-mA range:  $R_2 = 2.4 \text{ k}\Omega$  (typical)
- 0-mA to 20-mA range:  $R_2 = 3 \text{ k}\Omega$  (typical)
- 0-mA to 24-mA range:  $R_2 = 3.6 \text{ k}\Omega$  (typical)

The purpose of the 12.5-k $\Omega$  resistor is to create a filter when CAP1 and CAP2 are used.

To insert the external HART signal on the CAP2 terminal, an external ac-coupling capacitor is typically connected to CAP2. The high pass filter 3-dB frequency is determined by the resistive impedance looking into CAP2 ( $R_2 + 12.5 \text{ k}\Omega$ ) and the coupling-capacitor value. The 3-dB frequency is  $1 / (2 \times \pi \times [R_2 + 12.5 \text{ k}\Omega] \times [\text{Coupling Capacitor Value}])$ .

When the input HART frequency is greater than the 3-dB frequency, the ac signal is seen at the plus input of amplifier A2 and is therefore seen across the 40- $\Omega$  resistor. To generate a 1-mA signal on the output therefore requires a 40-mV peak-to-peak signal on CAP2. Because most HART modems do not output a 40-mV signal, a capacitive divider is used in Figure 60 to attenuate the FSK signal from the modem. In Figure 60, the high-pass cutoff frequency is  $1 / (2 \times \pi \times [R_2 + 12.5 \text{ k}\Omega] \times [C_1 + C_2])$ . There is one disadvantage to this approach: if the AVDD supply is not clean, any ripple on it could couple into the part.

## Application Information (continued)

### 9.1.1.2 Using the ISET-R Pin

The second method to implement HART is to couple the HART signal through the ISET-R terminal when IOU<sub>T</sub> is operated using an external R<sub>SET</sub> resistor. The FSK signal from the modem is ac-coupled into the terminal through a series combination of R<sub>in</sub> and C<sub>in</sub> as shown in Figure 61.

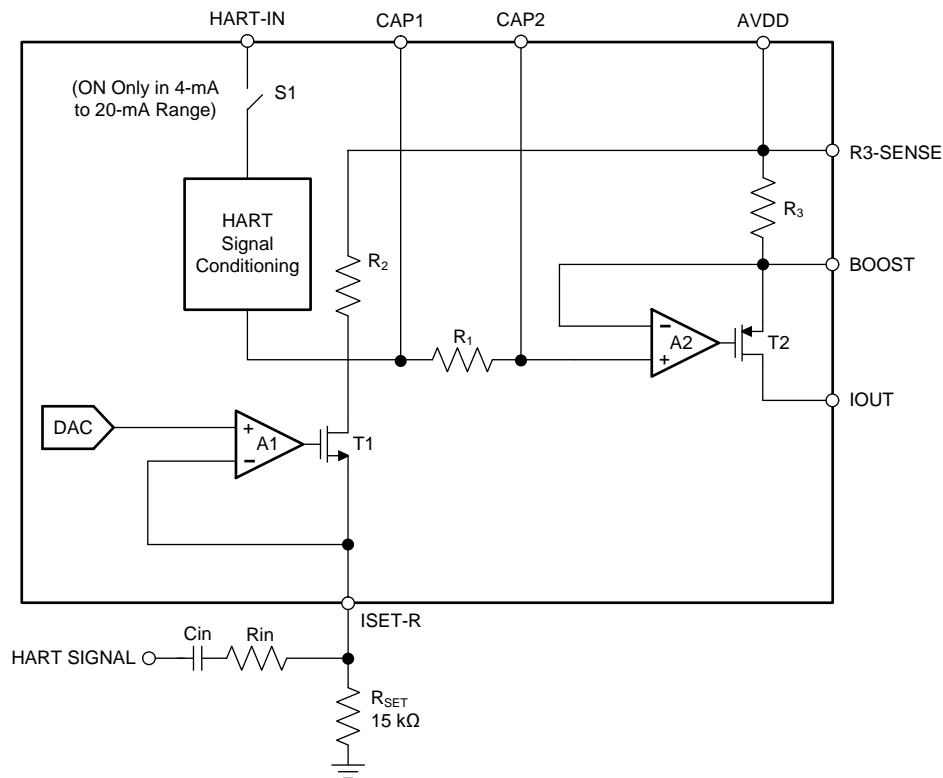

**Figure 61. Implementing HART with the ISET-R Terminal**

The magnitude of the ac-current output is calculated with Equation 6.

$$(V_{\text{HART}} \times k) / R_{\text{in}}$$

where

- $V_{\text{HART}}$  is the amplitude of the HART FSK signal from the modem
- $k$  is a constant that represents the gain transfer function from the ISET-R terminal to the IOU<sub>T</sub> terminal and depends on the selected current output range as follows:
  - $k = 60$  for the 4-mA to 20-mA range
  - $k = 75$  for the 0-mA to 20-mA range
  - $k = 90$  for the 0-mA to 24-mA range

(6)

The series input resistor and capacitor form a high-pass filter at the ISET-R terminal. Select C<sub>in</sub> to make sure that all signals in the HART extended-frequency band pass through unattenuated.

## 9.2 Typical Application

### 9.2.1 Voltage and Current Output Driver for Factory Automation AND Control, EMC/EMI Protected

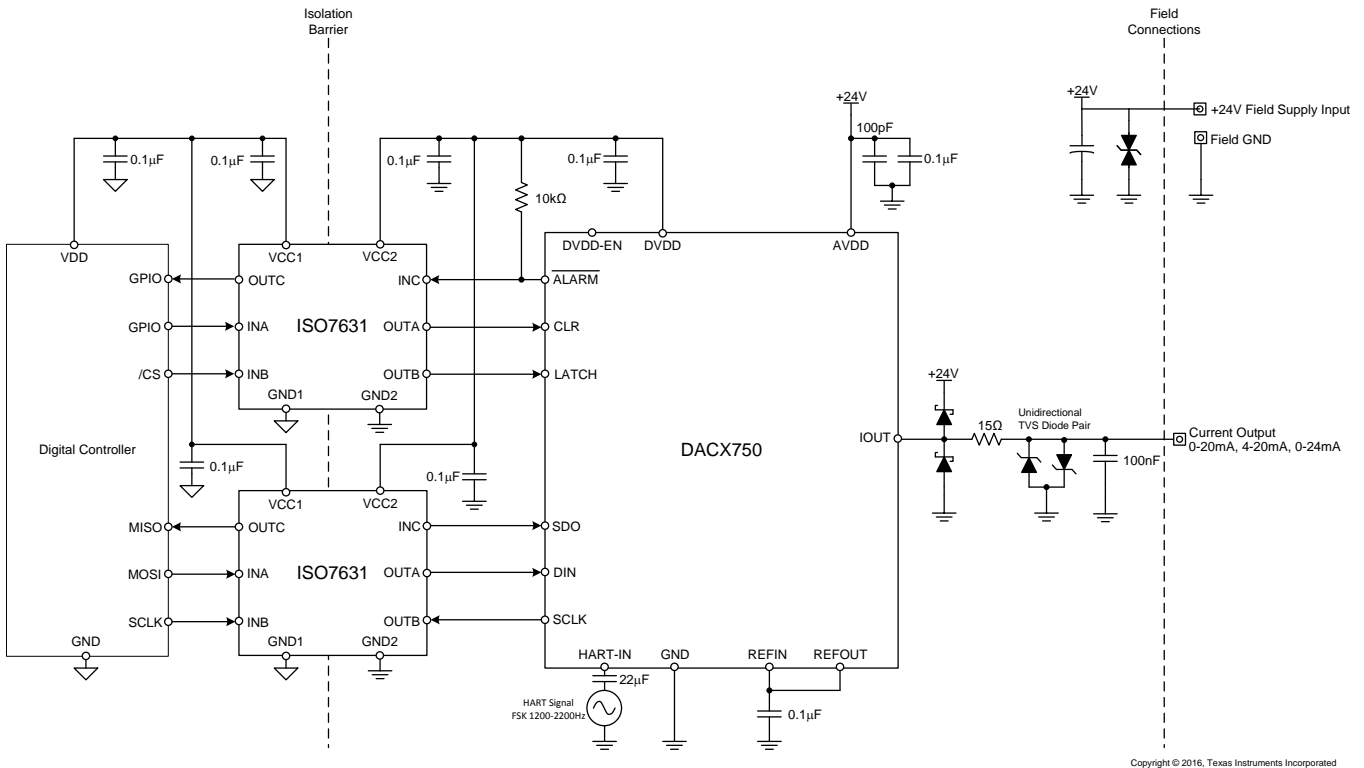

Figure 62. DACx750 in an Analog Output (AO) Module

#### 9.2.1.1 Design Requirements

Analog I/O modules are used by programmable logic controllers (PLCs) and distributed control systems (DCS) to interface to sensors, actuators, and other field instruments. These modules must meet stringent electrical specifications for both performance, as well as protection. These outputs are typically current loops based on the 4-mA to 20-mA range. Common error budgets accommodate 0.1% full-scale range total unadjusted error (% FSR TUE) at room temperature. Designs which desire stronger accuracy over temperature frequently implement calibration. Often times the PLC back-plane provides access to a 12-V to 36-V analog supply from which a majority of supply voltages are derived.

#### 9.2.1.2 Detailed Design Procedure

Figure 63 illustrates a common generic solution for realizing these desired voltage and current output spans.

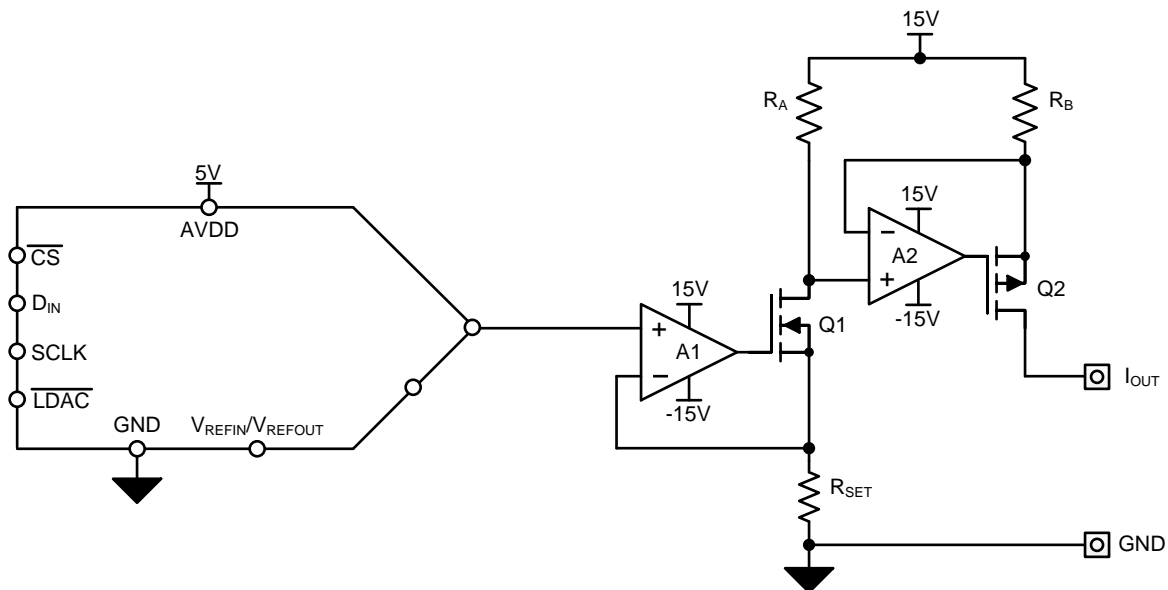
**Typical Application (continued)**

**Figure 63. Generic Design for Typical PLC Current and Voltage Outputs**

The current output circuit is comprised of amplifiers A1 and A2, MOSFETs Q1 and Q1, and the three resistors  $R_{SET}$ ,  $R_A$ , and  $R_B$ . This two-stage current source enables the ground-referenced DAC output voltage to drive the high-side amplifier required for the current-source.

The high-level of integration of the DACx750 family lends itself very well to the design of analog output modules, offering simplicity of design and reducing solution size. The DACx750 integrates all of the components shown in [Figure 63](#) allowing a software configurable current output driver. [Figure 62](#) illustrates an example circuit design for such an application using the DACx750 for the current output driver.

The design uses two triple channel isolators (ISO7631FC) to provide galvanic isolation for the digital lines to communicate to the main controller. Note that these isolators can be driven by the internally-generated supply (DVDD) from the DACx750 to save components and cost. The DACx750 supplies up to 10 mA that meets the supply requirements of the two isolators running at up to 10 Mbps. Note that additional cost savings are possible if noncritical digital signals such as CLR and ALARM are tied to GND or left unconnected. Finally, a protection scheme with transient voltage suppressors and other components is placed on all pins which connect to the field.

The protection circuitry is designed to provide immunity to the IEC61000-4 test suite which includes system-level industrial transient tests. The protection circuit includes transient voltage suppressor (TVS) diodes, clamp-to-rail steering diodes, and pass elements in the form of resistors and ferrite beads. For more detail about selecting these components, refer to [Single-Channel Industrial Voltage & Current Output Driver, Isolated, EMC/EMI Tested Reference Design](#).

### 9.2.1.3 Application Curve

The current output circuit was measured in 0-mA to 24-mA mode using an 8.5 digit digital multi-meter to measure the output while driving a 300- $\Omega$  load at 25°C. The measured results are illustrated in [Figure 64](#). The current output remains within the data sheet specified performance.

The design was also exposed to IEC61000-4 electrostatic discharge, electrically fast transient, conducted immunity, and radiated immunity tests on both the current and voltage outputs. During each of these tests a 6.5 digit digital multi-meter, set in fast 5.5 digit acquisition mode, was used to monitor the output. Complete data sets for the voltage and current outputs during these tests are available in [Single-Channel Industrial Voltage & Current Output Driver, Isolated, EMC/EMI Tested Reference Design](#).

**Typical Application (continued)**

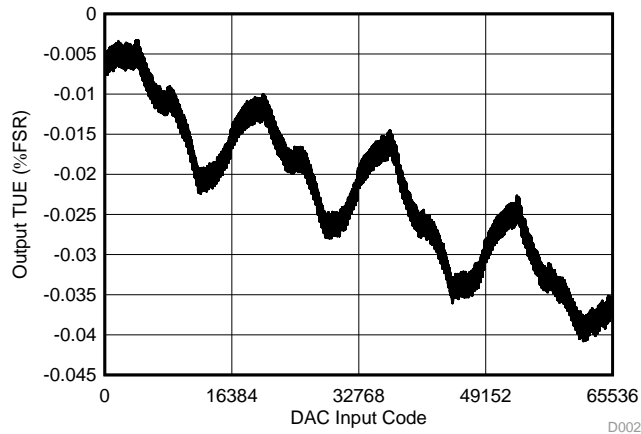

**Figure 64. Current Output TUE vs Code**

**10 Power Supply Recommendations**

The DACx750 family can operate within the specified single-supply range of 10 V to 36 V applied to the AVDD pin. The digital supply, DVDD, can operate within the specified supply range of 2.7 V to 5.5 V or be powered by the internal 4.6-V LDO. Switching power supplies and DC/DC converters often have high frequency glitches or spikes riding on the output voltage. In addition, digital components can create similar high frequency spikes. This noise can be easily coupled into the DAC output voltage or current through various paths between the power connections and analog output. TI recommends including bulk and local decoupling capacitors to further reduce noise. The current consumption on the AVDD pin and current ranges for the current output are listed in [Electrical Characteristics](#). The power supply must meet the requirements listed in the [Electrical Characteristics](#) table.

## 11 Layout

### 11.1 Layout Guidelines

To maximize the performance of the DACx750 in any application, good layout practices and proper circuit design must be followed. A few recommendations specific to the DACx750 are:

1. As illustrated in [Figure 60](#), CAP2 is directly connected to the input of the final IOUT amplifier. Any noise or unwanted ac signal routed near the CAP1 and CAP2 terminals could capacitively couple onto internal nodes and affect IOUT. Therefore, it is important to avoid routing any digital or HART signal traces over the CAP1 and CAP2 traces.
2. Connect the thermal PAD to the lowest potential in the system.
3. Make sure that AVDD has decoupling capacitors local to the respective terminals.
4. Place the reference capacitor close to the reference input terminal.
5. Avoid routing switching signals near the reference input.
6. For designs that include protection circuits:
  - a. Place diversion elements, such as TVS diodes or capacitors, close to off-board connectors to make sure that return current from high-energy transients does not cause damage to sensitive devices.
  - b. Use large, wide traces to provide a low-impedance path to divert high-energy transients away from I/O terminals.

### 11.2 Layout Example

[Figure 65](#) shows an example layout for the DAC8760 and DAC7760 devices from [TIPD153](#). A similar layout can be used for the DACx750 with a few modifications to account for pinout differences.

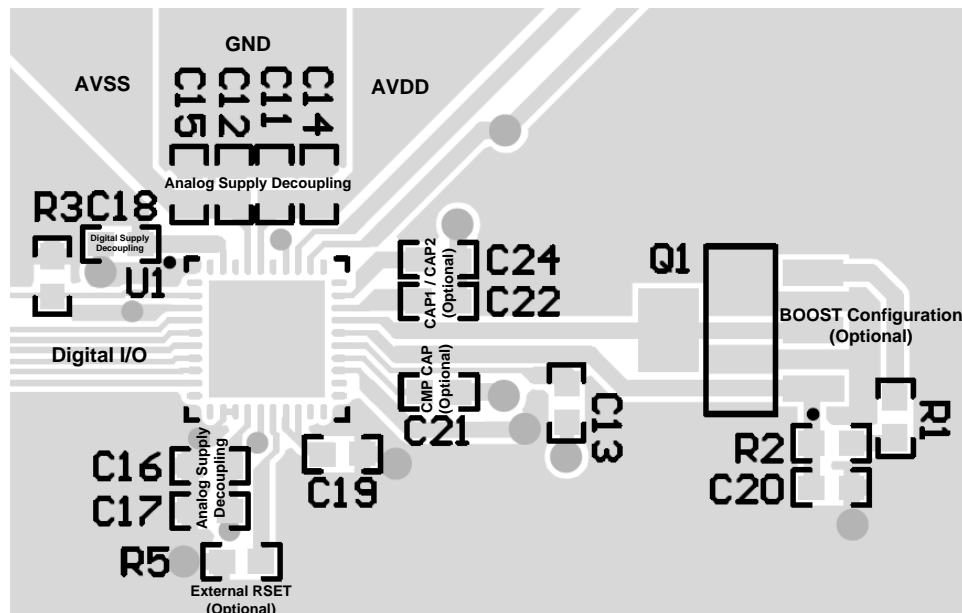

**Figure 65. Example Layout**

### 11.3 Thermal Considerations

The DACx750 is designed for a maximum junction temperature of 150°C. In cases where the maximum AVDD is driving maximum current into ground, this junction temperature can be exceeded. Use [Equation 7](#) to determine the maximum junction temperature that can be reached.

$$\text{Power dissipation} = (T_{J \text{ max}} - T_A) / \theta_{JA}$$

where

- $T_{J \text{ max}} = 150^\circ\text{C}$
- $T_A$  is the ambient temperature
- $\theta_{JA}$  is the package-dependent, junction-to-ambient thermal resistance, found in [Thermal Information](#). (7)

The power dissipation is calculated by multiplying all the supply voltages with the currents supplied, which are found in the *Power Requirements* subsection of [Electrical Characteristics](#).

Consider an example: IOOUT is enabled, supplying 24 mA into GND with a 25°C ambient temperature, AVDD of 24 V, and DVDD is generated internally. From the [Electrical Characteristics](#), the max value of AIDD = 3 mA when IOOUT is enabled and DAC code = 0x0000. Also, the max value of DIDD = 1 mA. Accordingly, the worst-case power dissipation is  $24 \text{ V} \times (24 \text{ mA} + 3 \text{ mA} + 1 \text{ mA}) = 672 \text{ mW}$ . Using the  $\theta_{JA}$  value for the TSSOP package, we get  $T_{J \text{ max}} = 25^\circ\text{C} + (32.3 \times 0.672)^\circ\text{C} = 46.7^\circ\text{C}$ . At 85°C ambient temperature, the corresponding value of  $T_{J \text{ max}}$  is 106.7°C. Using this type of analysis, the system designer can both specify and design for the equipment operating conditions. Note that for enhanced thermal performance, connect the thermal pad in both packages to a copper plane.

## 12 Device and Documentation Support

### 12.1 Documentation Support

#### 12.1.1 Related Documentation

For related documentation see the following:

- [Single-Channel Industrial Voltage & Current Output Driver, Isolated, EMC/EMI Tested Reference Design](#)
- [Implementing HART™ Communication with the DAC8760 Family](#)

### 12.2 Related Links

The table below lists quick access links. Categories include technical documents, support and community resources, tools and software, and quick access to order now.

**Table 21. Related Links**

PARTS	PRODUCT FOLDER	ORDER NOW	TECHNICAL DOCUMENTS	TOOLS & SOFTWARE	SUPPORT & COMMUNITY
DAC7750	<a href="#">Click here</a>	<a href="#">Click here</a>	<a href="#">Click here</a>	<a href="#">Click here</a>	<a href="#">Click here</a>
DAC8750	<a href="#">Click here</a>	<a href="#">Click here</a>	<a href="#">Click here</a>	<a href="#">Click here</a>	<a href="#">Click here</a>

### 12.3 Receiving Notification of Documentation Updates

To receive notification of documentation updates, navigate to the device product folder on ti.com. In the upper right corner, click on *Alert me* to register and receive a weekly digest of any product information that has changed. For change details, review the revision history included in any revised document.

### 12.4 Community Resources

The following links connect to TI community resources. Linked contents are provided "AS IS" by the respective contributors. They do not constitute TI specifications and do not necessarily reflect TI's views; see TI's [Terms of Use](#).

**TI E2E™ Online Community** *TI's Engineer-to-Engineer (E2E) Community*. Created to foster collaboration among engineers. At [e2e.ti.com](http://e2e.ti.com), you can ask questions, share knowledge, explore ideas and help solve problems with fellow engineers.

**Design Support** *TI's Design Support* Quickly find helpful E2E forums along with design support tools and contact information for technical support.

### 12.5 Trademarks

E2E is a trademark of Texas Instruments.

HART is a registered trademark of HART Communication Foundation.

SPI, QSPI are trademarks of Motorola, Inc.

All other trademarks are the property of their respective owners.

### 12.6 Electrostatic Discharge Caution



This integrated circuit can be damaged by ESD. Texas Instruments recommends that all integrated circuits be handled with appropriate precautions. Failure to observe proper handling and installation procedures can cause damage.

ESD damage can range from subtle performance degradation to complete device failure. Precision integrated circuits may be more susceptible to damage because very small parametric changes could cause the device not to meet its published specifications.

### 12.7 Glossary

[SLYZ022](#) — *TI Glossary*.

This glossary lists and explains terms, acronyms, and definitions.

### **13 Mechanical, Packaging, and Orderable Information**

The following pages include mechanical packaging and orderable information. This information is the most current data available for the designated devices. This data is subject to change without notice and revision of this document. For browser-based versions of this data sheet, refer to the left-hand navigation.

**PACKAGING INFORMATION**

Orderable Device	Status (1)	Package Type	Package Drawing	Pins	Package Qty	Eco Plan (2)	Lead/Ball Finish (6)	MSL Peak Temp (3)	Op Temp (°C)	Device Marking (4/5)	Samples
DAC7750IPWP	ACTIVE	HTSSOP	PWP	24	60	Green (RoHS & no Sb/Br)	CU NIPDAU	Level-3-260C-168 HR	-40 to 125	DAC7750	<a href="#">Samples</a>
DAC7750IPWPR	ACTIVE	HTSSOP	PWP	24	2000	Green (RoHS & no Sb/Br)	CU NIPDAU	Level-3-260C-168 HR	-40 to 125	DAC7750	<a href="#">Samples</a>
DAC7750IRHAR	ACTIVE	VQFN	RHA	40	2500	Green (RoHS & no Sb/Br)	CU NIPDAU	Level-3-260C-168 HR	-40 to 125	DAC7750	<a href="#">Samples</a>
DAC7750IRHAT	ACTIVE	VQFN	RHA	40	250	Green (RoHS & no Sb/Br)	CU NIPDAU	Level-3-260C-168 HR	-40 to 125	DAC7750	<a href="#">Samples</a>
DAC8750IPWP	ACTIVE	HTSSOP	PWP	24	60	Green (RoHS & no Sb/Br)	CU NIPDAU	Level-3-260C-168 HR	-40 to 125	DAC8750	<a href="#">Samples</a>
DAC8750IPWPR	ACTIVE	HTSSOP	PWP	24	2000	Green (RoHS & no Sb/Br)	CU NIPDAU	Level-3-260C-168 HR	-40 to 125	DAC8750	<a href="#">Samples</a>
DAC8750IRHAR	ACTIVE	VQFN	RHA	40	2500	Green (RoHS & no Sb/Br)	CU NIPDAU	Level-3-260C-168 HR	-40 to 125	DAC8750	<a href="#">Samples</a>
DAC8750IRHAT	ACTIVE	VQFN	RHA	40	250	Green (RoHS & no Sb/Br)	CU NIPDAU	Level-3-260C-168 HR	-40 to 125	DAC8750	<a href="#">Samples</a>

(1) The marketing status values are defined as follows:

**ACTIVE:** Product device recommended for new designs.

**LIFEBUY:** TI has announced that the device will be discontinued, and a lifetime-buy period is in effect.

**NRND:** Not recommended for new designs. Device is in production to support existing customers, but TI does not recommend using this part in a new design.

**PREVIEW:** Device has been announced but is not in production. Samples may or may not be available.

**OBSELETE:** TI has discontinued the production of the device.

(2) **RoHS:** TI defines "RoHS" to mean semiconductor products that are compliant with the current EU RoHS requirements for all 10 RoHS substances, including the requirement that RoHS substance do not exceed 0.1% by weight in homogeneous materials. Where designed to be soldered at high temperatures, "RoHS" products are suitable for use in specified lead-free processes. TI may reference these types of products as "Pb-Free".

**RoHS Exempt:** TI defines "RoHS Exempt" to mean products that contain lead but are compliant with EU RoHS pursuant to a specific EU RoHS exemption.

**Green:** TI defines "Green" to mean the content of Chlorine (Cl) and Bromine (Br) based flame retardants meet JS709B low halogen requirements of <=100ppm threshold. Antimony trioxide based flame retardants must also meet the <=1000ppm threshold requirement.

(3) MSL, Peak Temp. - The Moisture Sensitivity Level rating according to the JEDEC industry standard classifications, and peak solder temperature.

(4) There may be additional marking, which relates to the logo, the lot trace code information, or the environmental category on the device.

<sup>(5)</sup> Multiple Device Markings will be inside parentheses. Only one Device Marking contained in parentheses and separated by a "-" will appear on a device. If a line is indented then it is a continuation of the previous line and the two combined represent the entire Device Marking for that device.

<sup>(6)</sup> Lead/Ball Finish - Orderable Devices may have multiple material finish options. Finish options are separated by a vertical ruled line. Lead/Ball Finish values may wrap to two lines if the finish value exceeds the maximum column width.

**Important Information and Disclaimer:**The information provided on this page represents TI's knowledge and belief as of the date that it is provided. TI bases its knowledge and belief on information provided by third parties, and makes no representation or warranty as to the accuracy of such information. Efforts are underway to better integrate information from third parties. TI has taken and continues to take reasonable steps to provide representative and accurate information but may not have conducted destructive testing or chemical analysis on incoming materials and chemicals. TI and TI suppliers consider certain information to be proprietary, and thus CAS numbers and other limited information may not be available for release.

In no event shall TI's liability arising out of such information exceed the total purchase price of the TI part(s) at issue in this document sold by TI to Customer on an annual basis.

**TAPE AND REEL INFORMATION**

**QUADRANT ASSIGNMENTS FOR PIN 1 ORIENTATION IN TAPE**

\*All dimensions are nominal

Device	Package Type	Package Drawing	Pins	SPQ	Reel Diameter (mm)	Reel Width W1 (mm)	A0 (mm)	B0 (mm)	K0 (mm)	P1 (mm)	W (mm)	Pin1 Quadrant
DAC7750IPWPR	HTSSOP	PWP	24	2000	330.0	16.4	6.95	8.3	1.6	8.0	16.0	Q1
DAC7750IRHAR	VQFN	RHA	40	2500	330.0	16.4	6.3	6.3	1.1	12.0	16.0	Q2
DAC7750IRHAT	VQFN	RHA	40	250	180.0	16.4	6.3	6.3	1.1	12.0	16.0	Q2
DAC8750IPWPR	HTSSOP	PWP	24	2000	330.0	16.4	6.95	8.3	1.6	8.0	16.0	Q1
DAC8750IRHAR	VQFN	RHA	40	2500	330.0	16.4	6.3	6.3	1.1	12.0	16.0	Q2
DAC8750IRHAT	VQFN	RHA	40	250	180.0	16.4	6.3	6.3	1.1	12.0	16.0	Q2

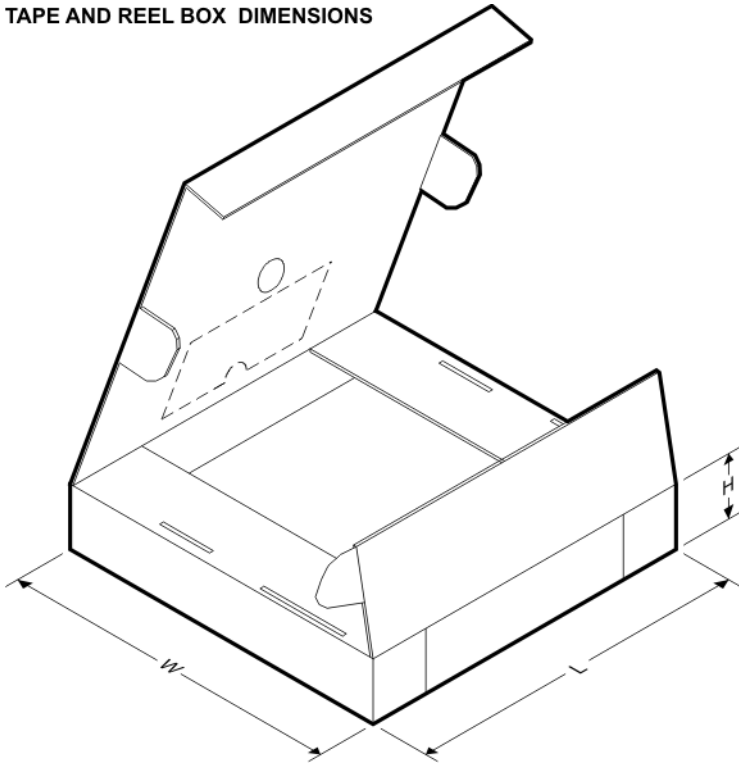
**TAPE AND REEL BOX DIMENSIONS**

\*All dimensions are nominal

Device	Package Type	Package Drawing	Pins	SPQ	Length (mm)	Width (mm)	Height (mm)
DAC7750IPWPR	HTSSOP	PWP	24	2000	350.0	350.0	43.0
DAC7750IRHAR	VQFN	RHA	40	2500	367.0	367.0	38.0
DAC7750IRHAT	VQFN	RHA	40	250	210.0	185.0	35.0
DAC8750IPWPR	HTSSOP	PWP	24	2000	350.0	350.0	43.0
DAC8750IRHAR	VQFN	RHA	40	2500	367.0	367.0	38.0
DAC8750IRHAT	VQFN	RHA	40	250	210.0	185.0	35.0

## GENERIC PACKAGE VIEW

**PWP 24**

**PowerPAD™ TSSOP - 1.2 mm max height**

4.4 x 7.6, 0.65 mm pitch

PLASTIC SMALL OUTLINE

This image is a representation of the package family, actual package may vary.  
Refer to the product data sheet for package details.

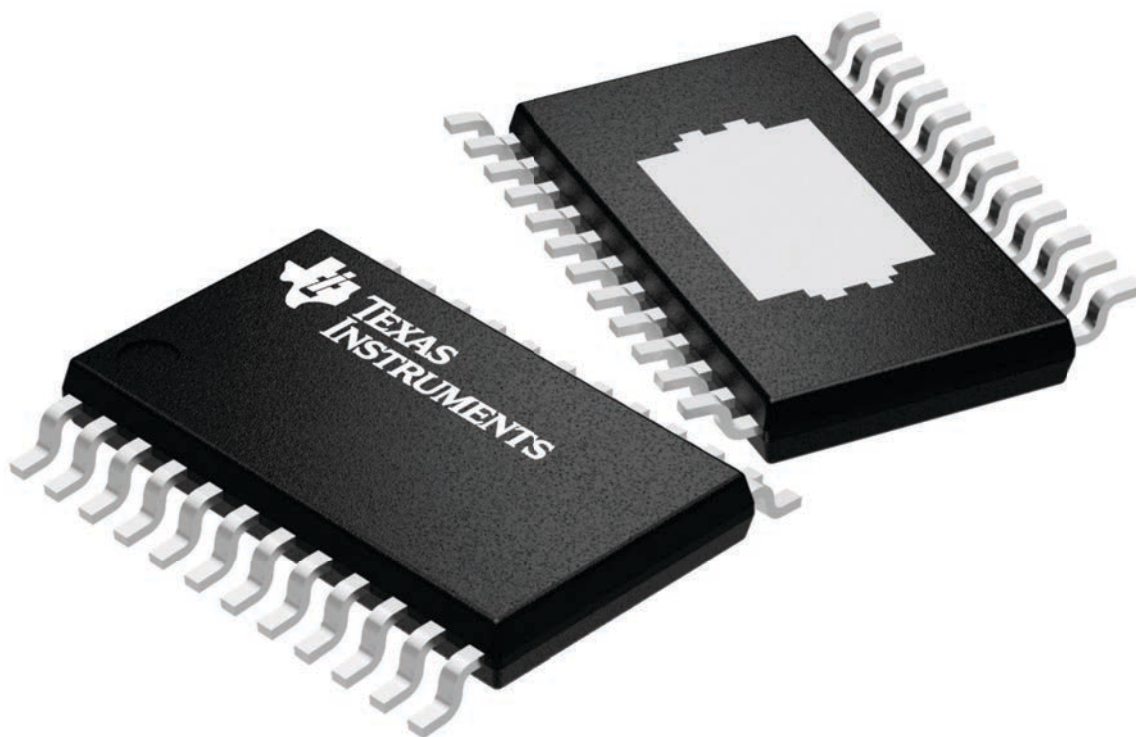

4224742/B

# MECHANICAL DATA

PWP (R-PDSO-G24)

PowerPAD™ PLASTIC SMALL OUTLINE

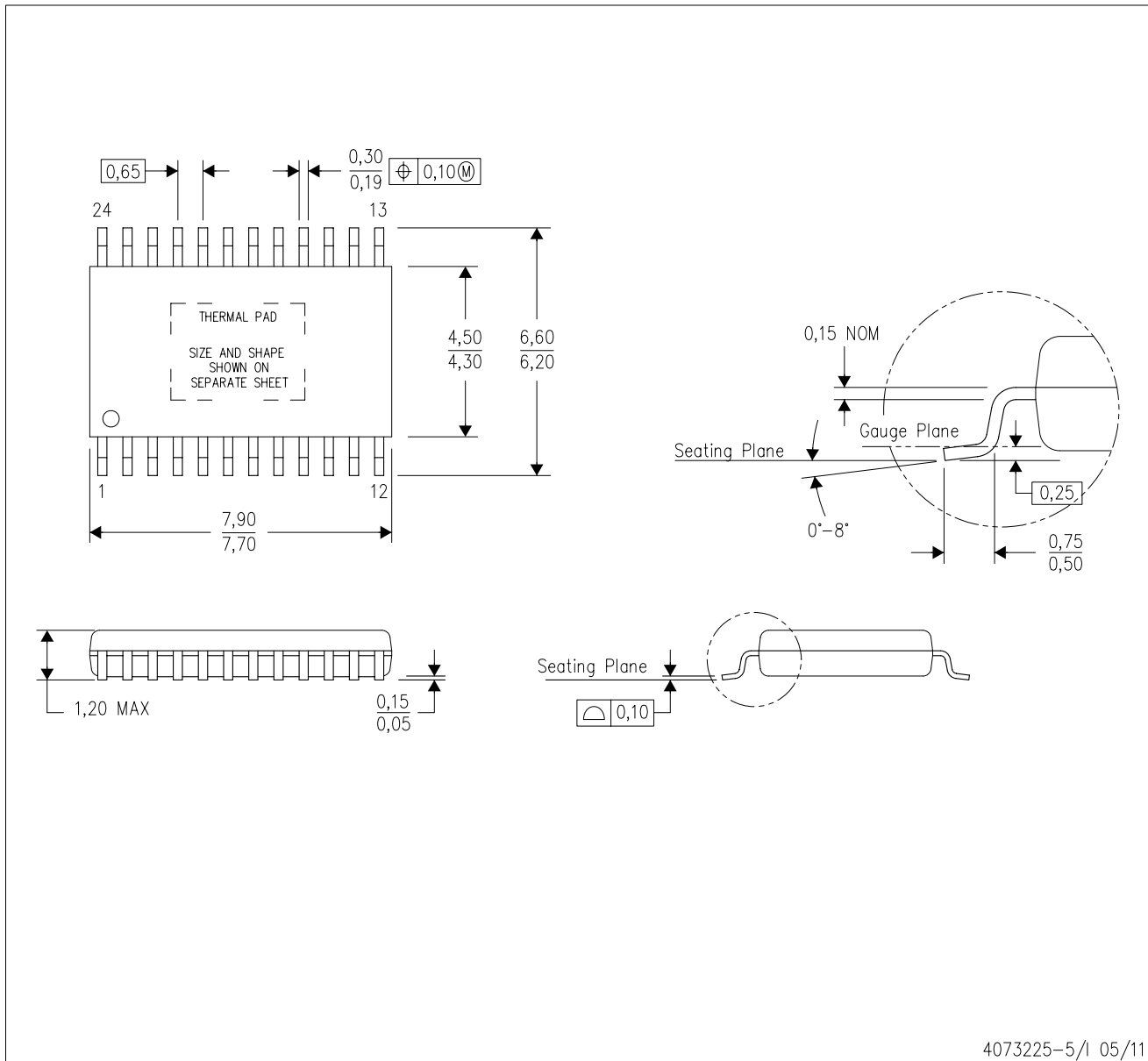

- NOTES:
- All linear dimensions are in millimeters.
  - This drawing is subject to change without notice.
  - Body dimensions do not include mold flash or protrusions. Mold flash and protrusion shall not exceed 0.15 per side.
  - This package is designed to be soldered to a thermal pad on the board. Refer to Technical Brief, PowerPad Thermally Enhanced Package, Texas Instruments Literature No. SLMA002 for information regarding recommended board layout. This document is available at [www.ti.com](http://www.ti.com) <<http://www.ti.com>>.
  - See the additional figure in the Product Data Sheet for details regarding the exposed thermal pad features and dimensions.
  - Falls within JEDEC MO-153

PowerPAD is a trademark of Texas Instruments.

# THERMAL PAD MECHANICAL DATA

## PWP (R-PDSO-G24) PowerPAD™ SMALL PLASTIC OUTLINE

### THERMAL INFORMATION

This PowerPAD™ package incorporates an exposed thermal pad that is designed to be attached to a printed circuit board (PCB). The thermal pad must be soldered directly to the PCB. After soldering, the PCB can be used as a heatsink. In addition, through the use of thermal vias, the thermal pad can be attached directly to the appropriate copper plane shown in the electrical schematic for the device, or alternatively, can be attached to a special heatsink structure designed into the PCB. This design optimizes the heat transfer from the integrated circuit (IC).

For additional information on the PowerPAD package and how to take advantage of its heat dissipating abilities, refer to Technical Brief, PowerPAD Thermally Enhanced Package, Texas Instruments Literature No. SLMA002 and Application Brief, PowerPAD Made Easy, Texas Instruments Literature No. SLMA004. Both documents are available at [www.ti.com](http://www.ti.com).

The exposed thermal pad dimensions for this package are shown in the following illustration.

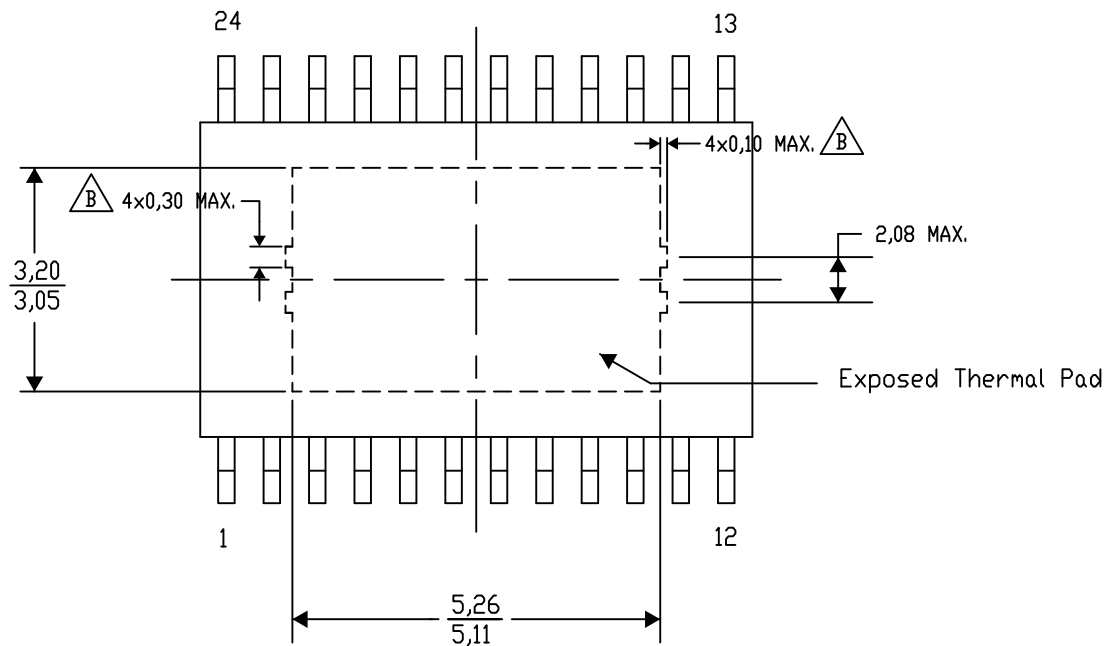

4206332-46/AO 01/16

NOTE: A. All linear dimensions are in millimeters

 B. Exposed tie strap features may not be present.

PowerPAD is a trademark of Texas Instruments

PWP (R-PDSO-G24)

PowerPAD™ PLASTIC SMALL OUTLINE

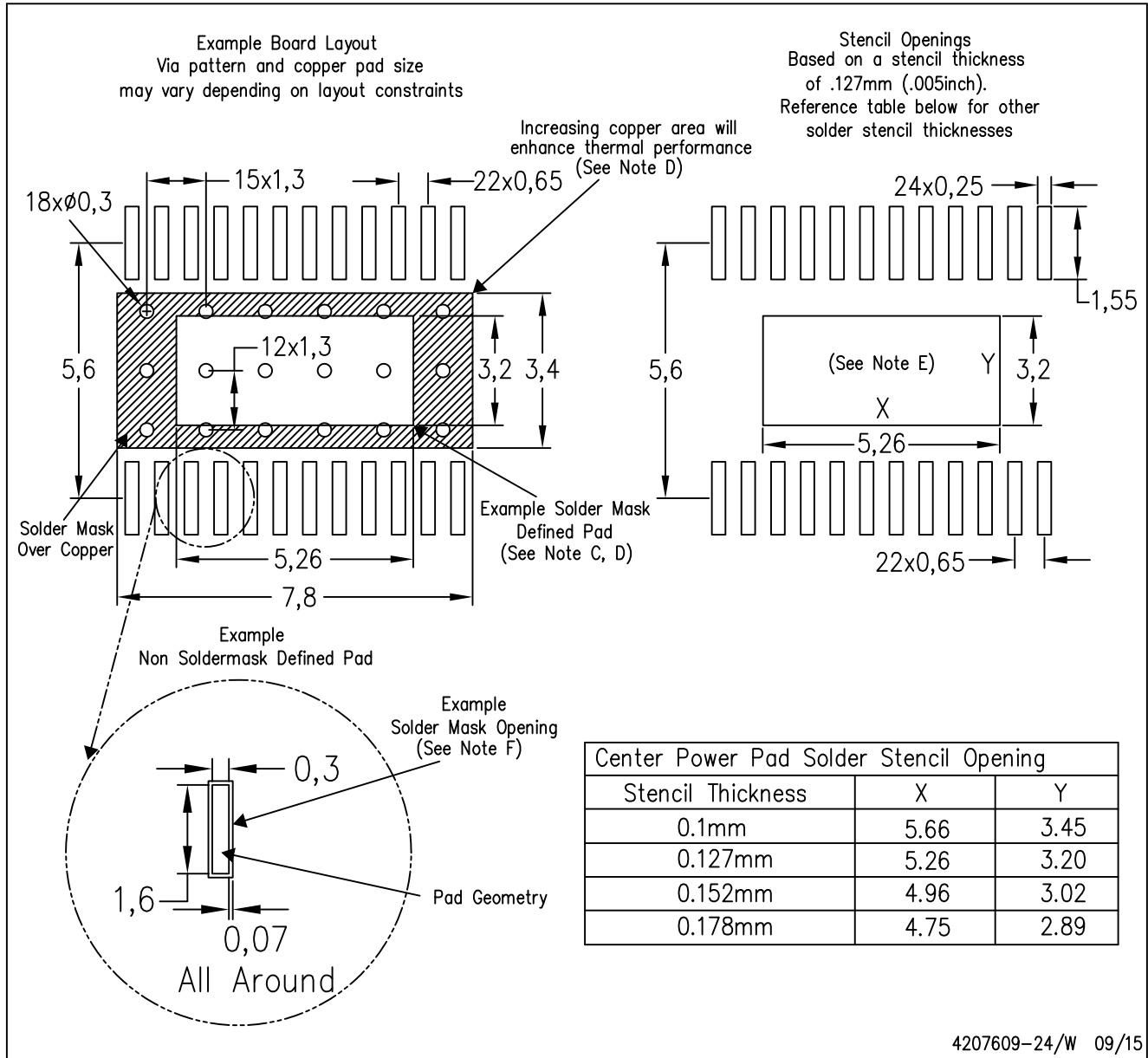

- NOTES:
- All linear dimensions are in millimeters.
  - This drawing is subject to change without notice.
  - Customers should place a note on the circuit board fabrication drawing not to alter the center solder mask defined pad.
  - This package is designed to be soldered to a thermal pad on the board. Refer to Technical Brief, PowerPad Thermally Enhanced Package, Texas Instruments Literature No. SLMA002, SLMA004, and also the Product Data Sheets for specific thermal information, via requirements, and recommended board layout. These documents are available at [www.ti.com](http://www.ti.com) <<http://www.ti.com>>.
  - Laser cutting apertures with trapezoidal walls and also rounding corners will offer better paste release. Customers should contact their board assembly site for stencil design recommendations. Example stencil design based on a 50% volumetric metal load solder paste.
  - Customers should contact their board fabrication site for solder mask tolerances between and around signal pads.

RHA (S-PVQFN-N40)

PLASTIC QUAD FLATPACK NO-LEAD

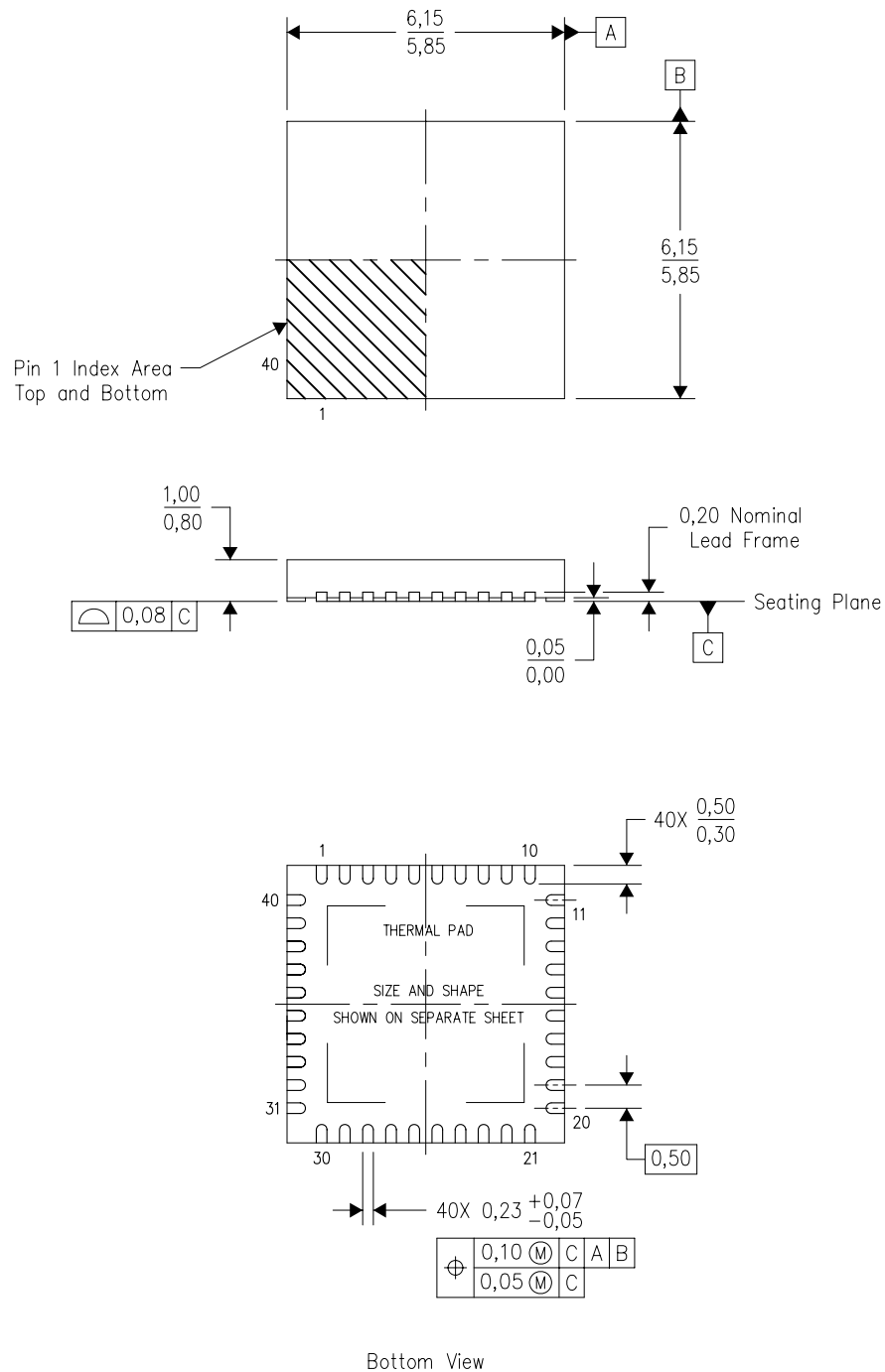

4204276/E 06/11

- NOTES:
- All linear dimensions are in millimeters. Dimensioning and tolerancing per ASME Y14.5M-1994.
  - This drawing is subject to change without notice.
  - QFN (Quad Flatpack No-Lead) Package configuration.
  - The package thermal pad must be soldered to the board for thermal and mechanical performance.
  - See the additional figure in the Product Data Sheet for details regarding the exposed thermal pad features and dimensions.
  - Package complies to JEDEC MO-220 variation VJJD-2.

## THERMAL PAD MECHANICAL DATA

RHA (S-PVQFN-N40)

PLASTIC QUAD FLATPACK NO-LEAD

### THERMAL INFORMATION

This package incorporates an exposed thermal pad that is designed to be attached directly to an external heatsink. The thermal pad must be soldered directly to the printed circuit board (PCB). After soldering, the PCB can be used as a heatsink. In addition, through the use of thermal vias, the thermal pad can be attached directly to the appropriate copper plane shown in the electrical schematic for the device, or alternatively, can be attached to a special heatsink structure designed into the PCB. This design optimizes the heat transfer from the integrated circuit (IC).

For information on the Quad Flatpack No-Lead (QFN) package and its advantages, refer to Application Report, QFN/SON PCB Attachment, Texas Instruments Literature No. SLUA271. This document is available at [www.ti.com](http://www.ti.com).

The exposed thermal pad dimensions for this package are shown in the following illustration.

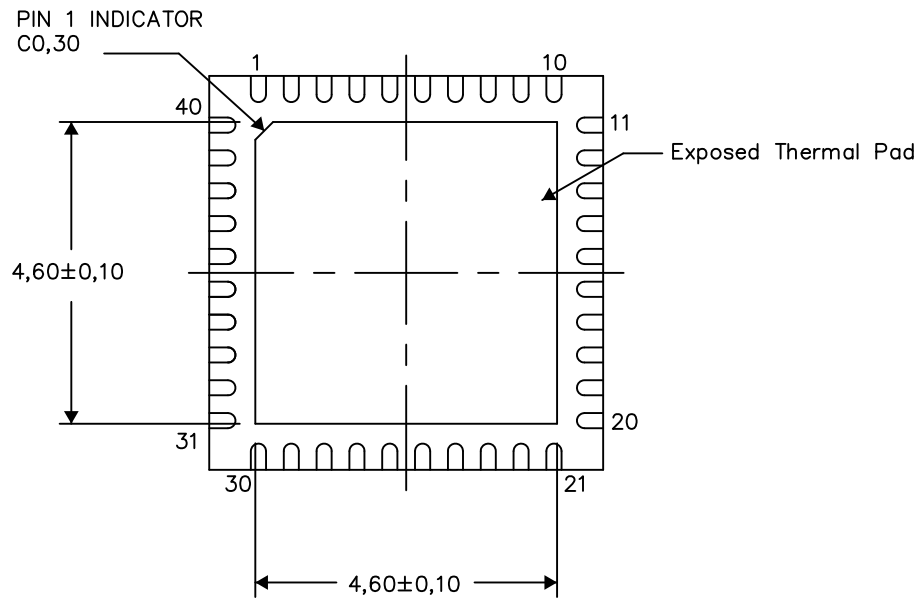

Bottom View

Exposed Thermal Pad Dimensions

4206355-5/X 08/14

NOTES: A. All linear dimensions are in millimeters

RHA (S-PVQFN-N40)

PLASTIC QUAD FLATPACK NO-LEAD

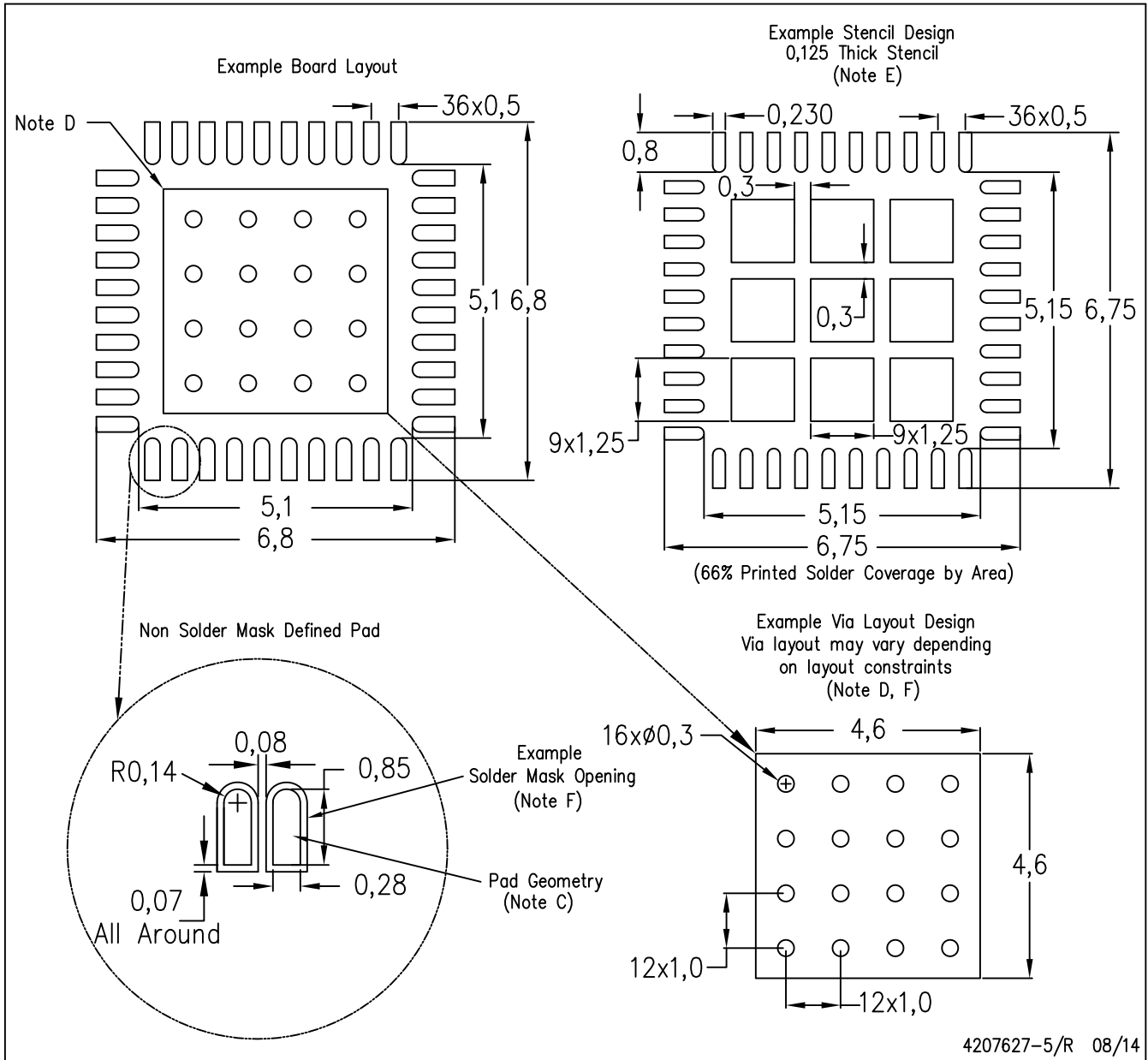

- NOTES:
- A. All linear dimensions are in millimeters.
  - B. This drawing is subject to change without notice.
  - C. Publication IPC-7351 is recommended for alternate designs.
  - D. This package is designed to be soldered to a thermal pad on the board. Refer to Application Note, Quad Flat-Pack Packages, Texas Instruments Literature No. SLUA271, and also the Product Data Sheets for specific thermal information, via requirements, and recommended board layout. These documents are available at [www.ti.com](http://www.ti.com) <<http://www.ti.com>>.
  - E. Laser cutting apertures with trapezoidal walls and also rounding corners will offer better paste release. Customers should contact their board assembly site for stencil design recommendations. Refer to IPC 7525 for stencil design considerations.
  - F. Customers should contact their board fabrication site for recommended solder mask tolerances and via tenting recommendations for vias placed in the thermal pad.

## IMPORTANT NOTICE AND DISCLAIMER

TI PROVIDES TECHNICAL AND RELIABILITY DATA (INCLUDING DATASHEETS), DESIGN RESOURCES (INCLUDING REFERENCE DESIGNS), APPLICATION OR OTHER DESIGN ADVICE, WEB TOOLS, SAFETY INFORMATION, AND OTHER RESOURCES "AS IS" AND WITH ALL FAULTS, AND DISCLAIMS ALL WARRANTIES, EXPRESS AND IMPLIED, INCLUDING WITHOUT LIMITATION ANY IMPLIED WARRANTIES OF MERCHANTABILITY, FITNESS FOR A PARTICULAR PURPOSE OR NON-INFRINGEMENT OF THIRD PARTY INTELLECTUAL PROPERTY RIGHTS.

These resources are intended for skilled developers designing with TI products. You are solely responsible for (1) selecting the appropriate TI products for your application, (2) designing, validating and testing your application, and (3) ensuring your application meets applicable standards, and any other safety, security, or other requirements. These resources are subject to change without notice. TI grants you permission to use these resources only for development of an application that uses the TI products described in the resource. Other reproduction and display of these resources is prohibited. No license is granted to any other TI intellectual property right or to any third party intellectual property right. TI disclaims responsibility for, and you will fully indemnify TI and its representatives against, any claims, damages, costs, losses, and liabilities arising out of your use of these resources.

TI's products are provided subject to TI's Terms of Sale ([www.ti.com/legal/termsofsale.html](http://www.ti.com/legal/termsofsale.html)) or other applicable terms available either on [ti.com](http://ti.com) or provided in conjunction with such TI products. TI's provision of these resources does not expand or otherwise alter TI's applicable warranties or warranty disclaimers for TI products.

Mailing Address: Texas Instruments, Post Office Box 655303, Dallas, Texas 75265  
Copyright © 2019, Texas Instruments Incorporated





## Looking for pricing, stock, or lifecycle information?

Click below to explore more details on WIN SOURCE:

 [View DAC7750IRHAT on WIN SOURCE](#)

 [Texas Instruments](#) Information

## Optimize Your Supply Chain with WIN SOURCE Solutions

-  Global Sourcing Solution
-  Obsolete Management
-  Cost Control Management
-  Shortage Management
-  Alternative Solution
-  Excess Inventory Management