

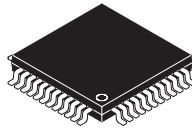

THE DATASHEET OF DAC5675IPHPG4





14-BIT, 400-MSPS DIGITAL-TO-ANALOG CONVERTER

FEATURES

- **400-MSPS Update Rate**
- **LVDS-Compatible Input Interface**
- **Spurious Free Dynamic Range (SFDR) to Nyquist**
 - 69 dBc at 70-MHz IF, 400 MSPS
- **W-CDMA Adjacent Channel Power Ratio ACPR**
 - 73 dBc at 30.72-MHz IF, 122.88 MSPS
 - 71 dBc at 61.44-MHz IF, 245.76 MSPS
- **Differential Scalable Current Outputs: 2 mA to 20 mA**
- **On-Chip 1.2-V Reference**
- **Single 3.3-V Supply Operation**
- **Power Dissipation: 820 at $f_{clk} = 400$ MSPS, $f_{out} = 70$ MHz**
- **Package: 48-Pin HTQFP PowerPad™, $T_{JA} = 28.8^{\circ}\text{C/W}$**

APPLICATIONS

- **Cellular Base Transceiver Station Transmit Channel**
 - CDMA: WCDMA, CDMA2000, IS-95
 - TDMA: GSM, IS-136, EDGE/GPRS
 - Supports Single-Carrier and Multicarrier Applications
- **Test and Measurement: Arbitrary Waveform Generation**
- **Direct Digital Synthesis (DDS)**
- **Cable Modem Headend**

DESCRIPTION

The DAC5675 is a 14-bit resolution high-speed digital-to-analog converter. The DAC5675 is designed for high-speed digital data transmission in wired and wireless communication systems, high-frequency direct-digital synthesis (DDS), and waveform reconstruction in test and measurement applications. The DAC5675 has excellent spurious free dynamic range (SFDR) at high intermediate frequencies, which makes the DAC5675 well suited for multicarrier transmission in TDMA and CDMA based cellular base transceiver stations BTS.

The DAC5675 operates from a single-supply voltage of 3.3 V. Power dissipation is 820 mW at $f_{clk} = 400$ MSPS, $f_{out} = 70$ MHz. The DAC5675 provides a nominal full-scale differential current output of 20 mA, supporting both single-ended and differential applications. The output current can be directly fed to the load with no additional external output buffer required. The output is referred to the analog supply voltage AVDD.

The DAC5675 is manufactured on Texas Instruments advanced high-speed mixed-signal BiCMOS process.

The DAC5675 comprises a LVDS (low-voltage differential signaling) interface. LVDS features a low differential voltage swing with a low constant power consumption across frequency, allowing for high speed data transmission with low noise levels, i.e., low electromagnetic interference (EMI). LVDS is typically implemented in low-voltage digital CMOS processes, making it the ideal technology for high-speed interfacing between the DAC5675 and high-speed low-voltage CMOS ASICs or FPGAs. The DAC5675 current-source-array architecture supports update rates of up to 400 MSPS. On-chip edge-triggered input latches provide for minimum setup and hold times thereby relaxing interface timing.



Please be aware that an important notice concerning availability, standard warranty, and use in critical applications of Texas Instruments semiconductor products and disclaimers thereto appears at the end of this data sheet.

PowerPAD is a trademark of Texas Instruments. All other trademarks are the property of their respective owners.

PRODUCTION DATA information is current as of publication date. Products conform to specifications per the terms of Texas Instruments standard warranty. Production processing does not necessarily include testing of all parameters.

Copyright © 2002 – 2004, Texas Instruments Incorporated

DESCRIPTION (continued)

The DAC5675 has been specifically designed for a differential transformer coupled output with a 50-Ω doubly terminated load. With the 20-mA full-scale output current, both a 4:1 impedance ratio (resulting in an output power of 4 dBm) and 1:1 impedance ratio transformer (-2 dBm) is supported. The last configuration is preferred for optimum performance at high output frequencies and update rates. The output voltage compliance ranges from 2.15 V to AVDD + 0.03 V.

An accurate on-chip 1.2-V temperature compensated bandgap reference and control amplifier allows the user to adjust this output current from 20 mA down to 2 mA. This provides 20-dB gain range control capabilities. Alternatively, an external reference voltage may be applied. The DAC5675 features a SLEEP mode, which reduces the standby power to approximately 150 mW.

The DAC5675 is available in a 48-pin HTQFP thermally enhanced PowerPad package. This package increases thermal efficiency in a standard size IC package. The device is characterized for operation over the industrial temperature range of -40°C to 85°C.

**PHP PACKAGE
(TOP VIEW)**

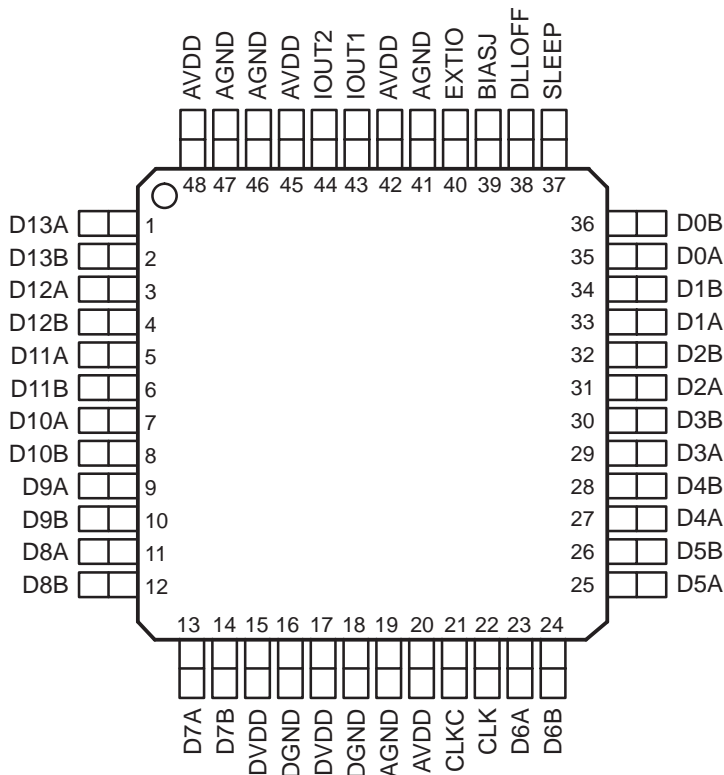

AVAILABLE OPTIONS

T _A	PACKAGED DEVICE
	-40°C to 85°C
DAC5675IPHP	
DAC5675IPHPR	

functional block diagram

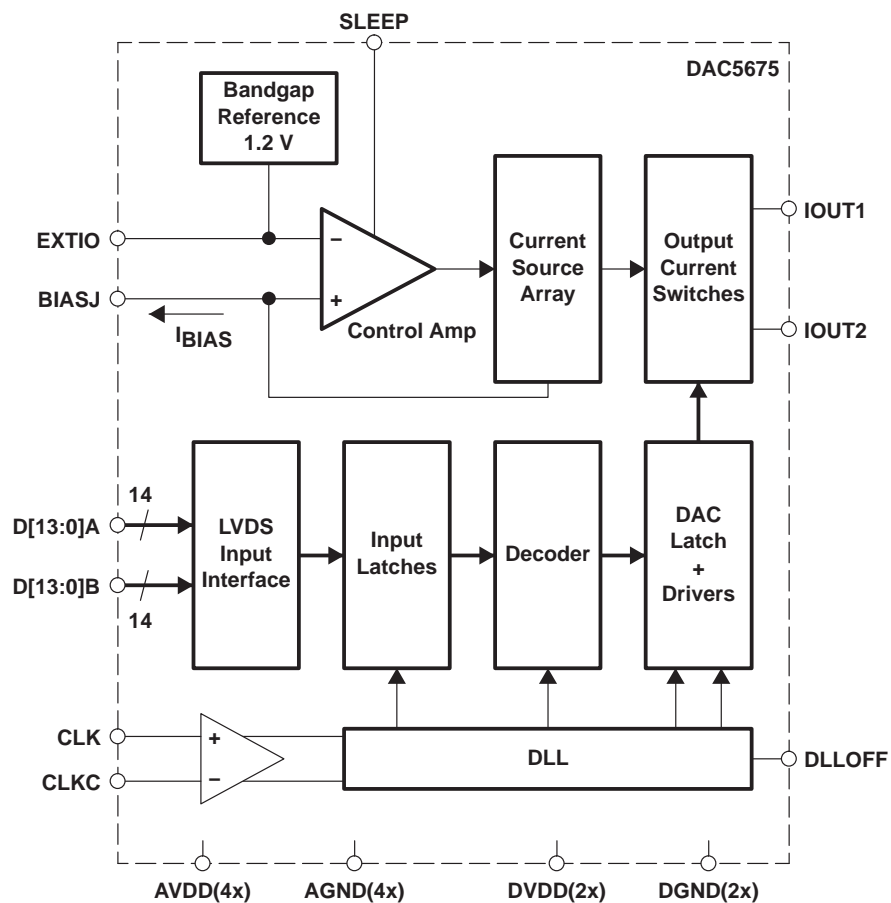

Terminal Functions

TERMINAL NAME NO.		I/O	DESCRIPTION
AGND	19, 41, 46, 47	I	Analog negative supply voltage (ground)
AVDD	20, 42, 45, 48	I	Analog positive supply voltage
BIASJ	39	O	Full-scale output current bias
CLK	22	I	External clock input
CLKC	21	I	Complementary external clock input
D[13..0]A	1, 3, 5, 7, 9, 11, 13, 23, 25, 27, 29, 31, 33, 35	I	LVDS positive input, data bits 0 through 13 D13A is most significant data bit (MSB) D0A is least significant data bit (MSB)
D[13..0]B	2, 4, 6, 8, 10, 12, 14, 24, 26, 28, 30, 32, 34, 36	I	LVDS negative input, data bits 0 through 13 D13B is most significant data bit (MSB) D0B is least significant data bit (MSB)
DGND	16, 18	I	Digital negative supply voltage (ground)
DLLOFF	38	I	High DLL off / Low = DLL on
DVDD	15, 17	I	Digital positive supply voltage
EXTIO	40	I/O	Internal reference output or external reference input. Requires a 0.1- μ F decoupling capacitor to AGND when used as reference output.
IOUT1	43	O	DAC current output. Full scale when all input bits are set 1. Connect reference side of DAC load resistors to AVDD
IOUT2	44	O	DAC complementary current output. Full scale when all input bits are 0. Connect reference side of DAC load resistors to AVDD
SLEEP	37	I	Asynchronous hardware power down input. Active high. No pull down or pull up. Must be asserted high or low.

detailed description (continued)

digital inputs

The DAC5675 comprises a low voltage differential signaling (LVDS) bus input interface. The LVDS features a low differential voltage swing with low constant power consumption (~4 mA per complementary data input) across frequency. The differential characteristic of LVDS allows for high-speed data transmission with low electromagnetic interference (EMI) levels. The LVDS input minimum and maximum input threshold table lists the LVDS input levels. Figure 2 shows the equivalent complementary digital input interface for the DAC5675, valid for pins D[13..0]A and D[13..0]B. Note that the LVDS interface features internal 110-Ω resistors for proper termination. Figure 3 shows the LVDS input timing measurement circuit and waveforms. A common mode level of 1.2 V and a differential input swing of 0.8 V is applied to the inputs.

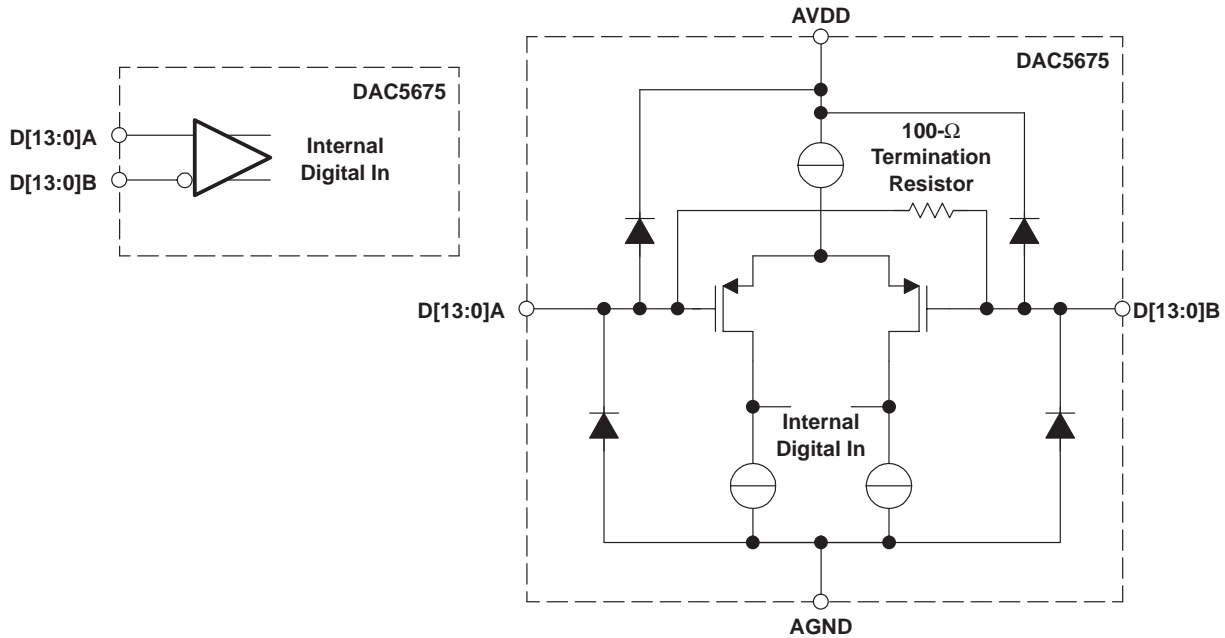

Figure 2. LVDS Digital Equivalent Input

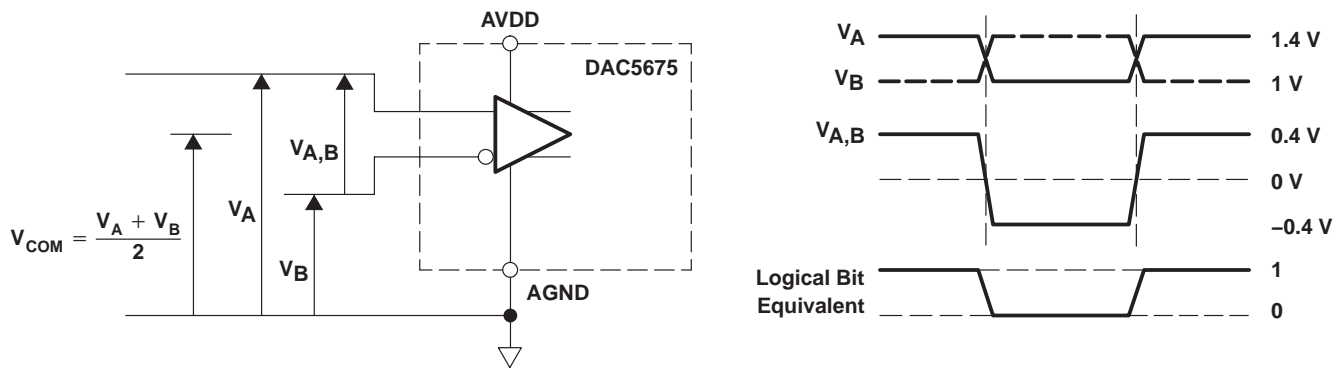

Figure 3. LVDS Timing Test Circuit and Input Test Levels

digital inputs (continued)

Figure 4 shows a schematic of the equivalent CMOS/TTL-compatible digital inputs of the DAC5675, valid for pins SLEEP and DLLOFF.

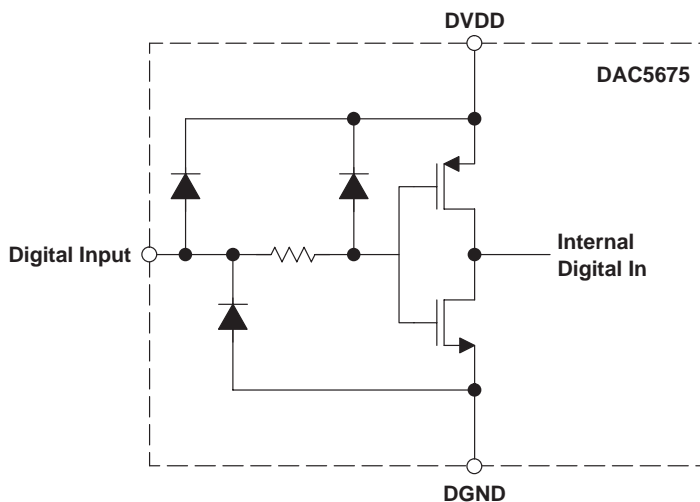

Figure 4. CMOS/TTL Digital Equivalent Input

clock input and timing

The DAC5675 comprises a delay locked loop DLL for internal clock alignment. Enabling the DLL is controlled by pin DLLOFF. The DLL should be enabled for update rates in excess of 100 MSPS. The DLL works only to maximize setup and hold times of the digital input and does not affect the analog output of the DAC. Figure 5 shows the clock and data input timing diagram. The DAC5675 features a differential clock input. Internal edge-triggered flip-flops latch the input word on the rising edge of the positive clock input CLK (falling edge of the negative/complementary clock input CLKC). The DAC core is updated with the data word on the following rising edge of the positive clock input CLK (falling edge of CLKC). This results in a conversion latency of one clock cycle. The DAC5675 provides for minimum setup and hold times (>0.25 ns), allowing for noncritical external interface timing. The clock duty cycle can be chosen arbitrarily under the timing constraints listed in the *electrical characteristics* section. However, a 50% duty cycle gives the optimum dynamic performance.

The DAC5675 clock input can be driven by a differential sine wave. The ac coupling, in combination with internal biasing ensures that the sine wave input is centered at the optimum common-mode voltage that is required for the internal clock buffer. The DAC5675 clock input can also be driven single-ended, this is shown in Figure 6. The best SFDR performance is typically achieved by driving the inputs differentially.

clock input and timing (continued)

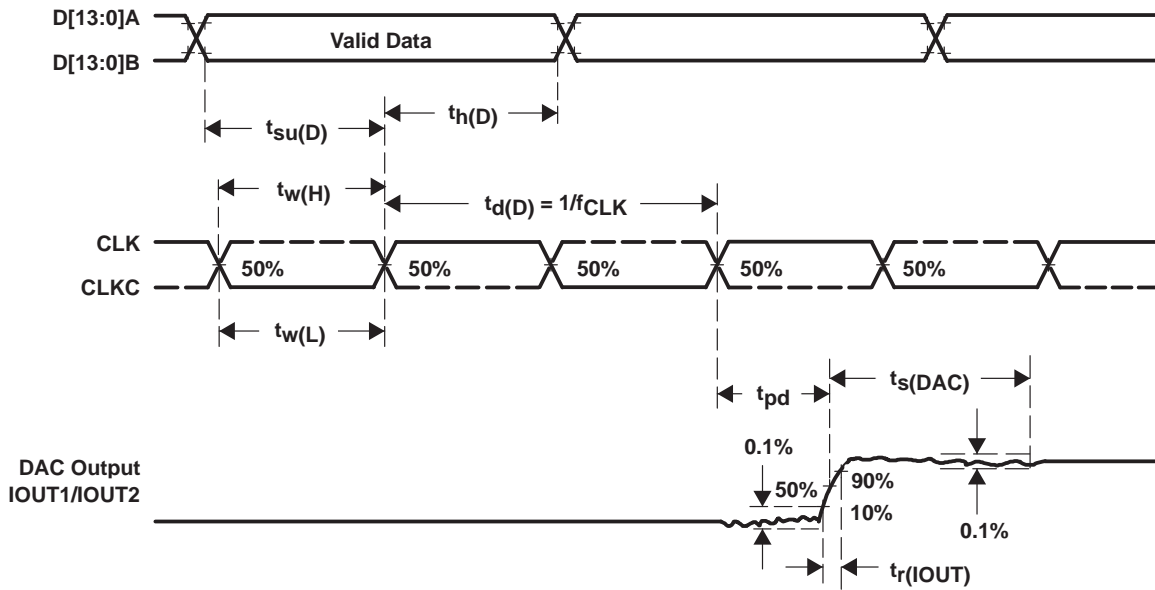

Figure 5. Timing Diagram

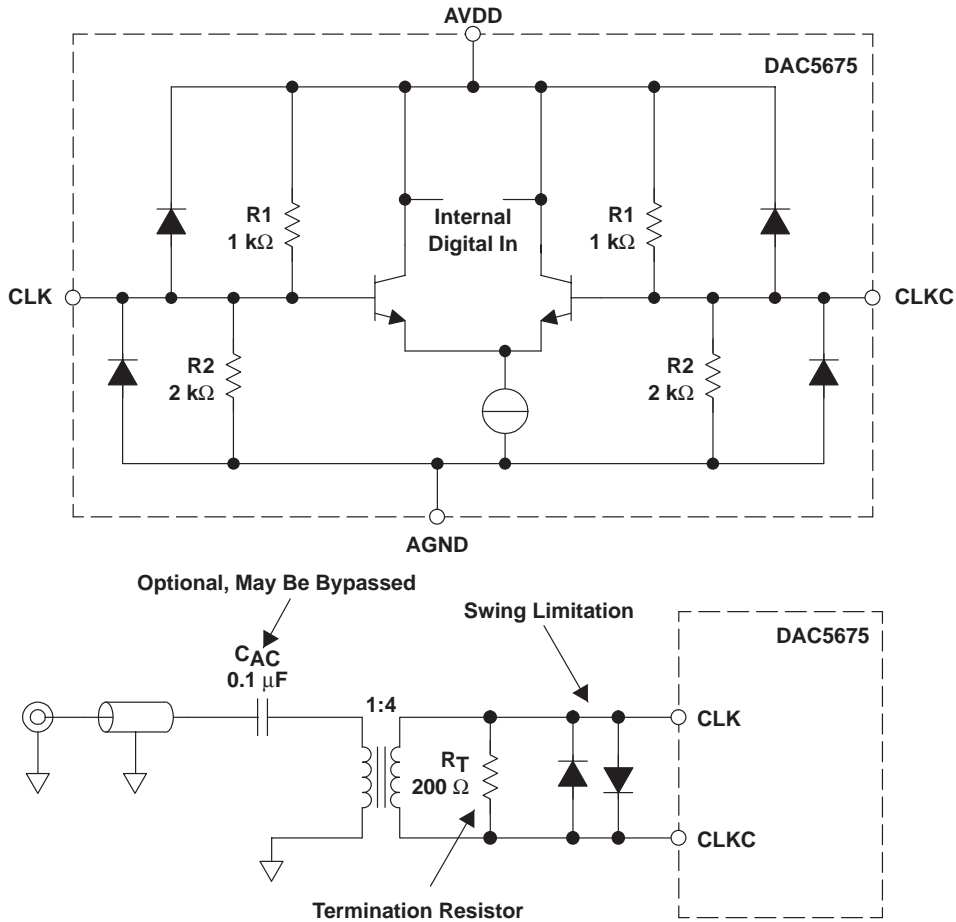

Figure 6. Clock Equivalent Input

clock input and timing (continued)

Figure 7 shows the equivalent schematic of the differential clock input buffer. The input nodes are internally self-biased enabling ac coupling of the clock inputs. Figure 8 shows the preferred configuration for driving the DAC5675.

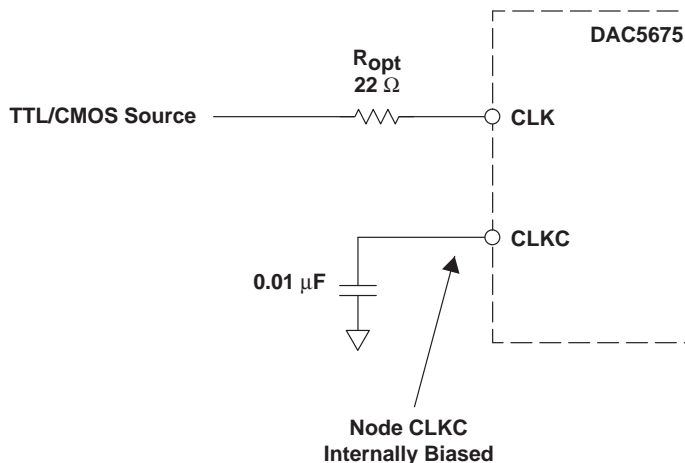

Figure 7. Driving the DAC5675 With a Single-Ended TTL/CMOS Clock Source

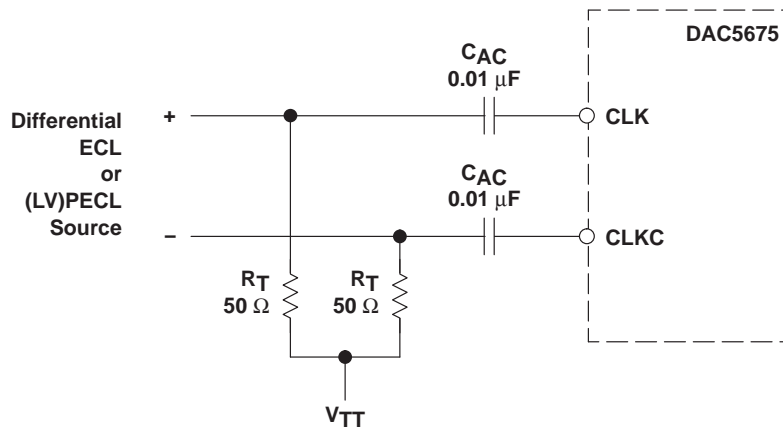

Figure 8. Driving the DAC5675 With a Differential ECL/PECL Clock Source

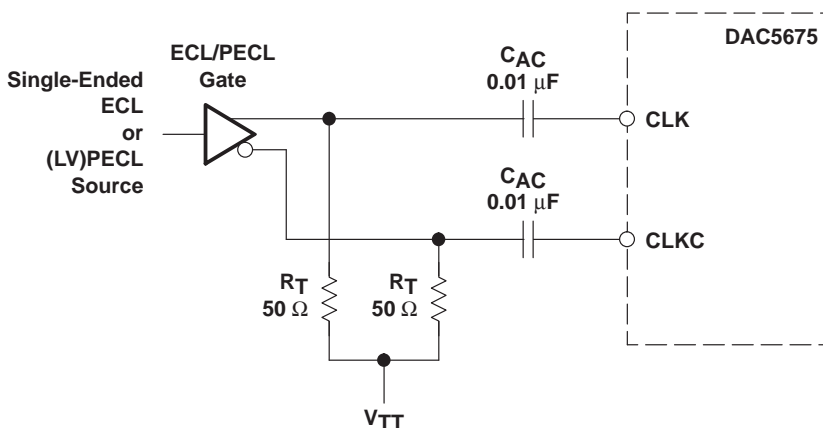

Figure 9. Driving the DAC5675 With a Single-Ended ECL/PECL Clock Source

detailed description (continued)

supply inputs

The DAC5675 comprises separate analog and digital supplies, i.e., AV_{DD} and DV_{DD} respectively. These supply inputs can be set independently from 3.6 V down to 3.15 V.

DAC transfer function

The DAC5675 delivers complementary output currents I_{OUT1} and I_{OUT2} . The DAC supports straight binary coding, with D13 being the MSB and D0 the LSB (For ease of notation we denote D13..D10 as the logical bit equivalent of the complementary LVDS inputs D[13..0]A and D[13..0]B). Output current I_{OUT1} equals the approximate full-scale output current when all input bits are set high, i.e., the binary input word has the decimal representation 16383. Full-scale output current flows through terminal I_{OUT2} when all input bits are set low (mode 0, straight binary input). The relation between I_{OUT1} and I_{OUT2} can thus be expressed as:

$$I_{OUT1} = I_{O(FS)} - I_{OUT2}$$

where $I_{O(FS)}$ is the full-scale output current. The output currents can be expressed as:

$$I_{OUT1} = \frac{I_{O(FS)} \times \text{CODE}}{16384}$$

$$I_{OUT2} = \frac{I_{O(FS)} \times (16383 - \text{CODE})}{16384}$$

where CODE is the decimal representation of the DAC data input word. Output currents I_{OUT1} and I_{OUT2} drive a load R_L . R_L is the combined impedance for the termination resistance and/or transformer load resistance, R_{LOAD} (see Figures 11 and 12). This would translate into single-ended voltages V_{OUT1} and V_{OUT2} at terminal I_{OUT1} and I_{OUT2} , respectively, of:

$$V_{OUT1} = I_{OUT1} \times R_L = \frac{\text{CODE} \times I_{O(FS)} \times R_L}{16384}$$

$$V_{OUT2} = I_{OUT2} \times R_L = \frac{(16383 - \text{CODE}) \times I_{O(FS)} \times R_L}{16384}$$

The differential output voltage $V_{OUT(DIFF)}$ can thus be expressed as:

$$V_{OUT(DIFF)} = V_{OUT1} - V_{OUT2} = \frac{(2\text{CODE} - 16383) \times I_{O(FS)} \times R_L}{16384}$$

The latter equation shows that applying the differential output results in doubling of the signal power delivered to the load. Since the output currents I_{OUT1} and I_{OUT2} are complementary, they become additive when processed differentially. Note that care should be taken not to exceed the compliance voltages at node I_{OUT1} and I_{OUT2} , which leads to increased signal distortion.

detailed description (continued)

reference operation

The DAC5675 comprises a bandgap reference and control amplifier for biasing the full-scale output current. The full-scale output current is set by applying an external resistor R_{BIAS} . The bias current I_{BIAS} through resistor R_{BIAS} is defined by the on-chip bandgap reference voltage and control amplifier. The full-scale output current equals 16 times this bias current. The full-scale output current $I_{O(FS)}$ is thus expressed as:

$$I_{O(FS)} = 16 \times I_{BIAS} = \frac{16 \times V_{EXTIO}}{R_{BIAS}}$$

where V_{EXTIO} is the voltage at terminal EXTIO. The bandgap reference voltage delivers an accurate voltage of 1.2 V. This reference can be override by applying a external voltage to terminal EXTIO. The bandgap reference can additionally be used for external reference operation. In that case, an external buffer with high impedance input should be applied in order to limit the bandgap load current to a maximum of 100 nA. The capacitor C_{EXT} may be omitted. Terminal EXTIO serves as either a input or output node. The full-scale output current is adjustable from 20 mA down to 2 mA by varying resistor R_{BIAS} .

analog current outputs

Figure 10 shows a simplified schematic of the current source array output with corresponding switches. Differential non switches direct the current of each individual PMOS current source to either the positive output node IOOUT1 or its complementary negative output node IOOUT2. The output impedance is determined by the stack of the current sources and differential switches, and is $>300 \text{ k}\Omega$ in parallel with an output capacitance of 5 pF.

The external output resistors are referred to the positive supply AVDD.

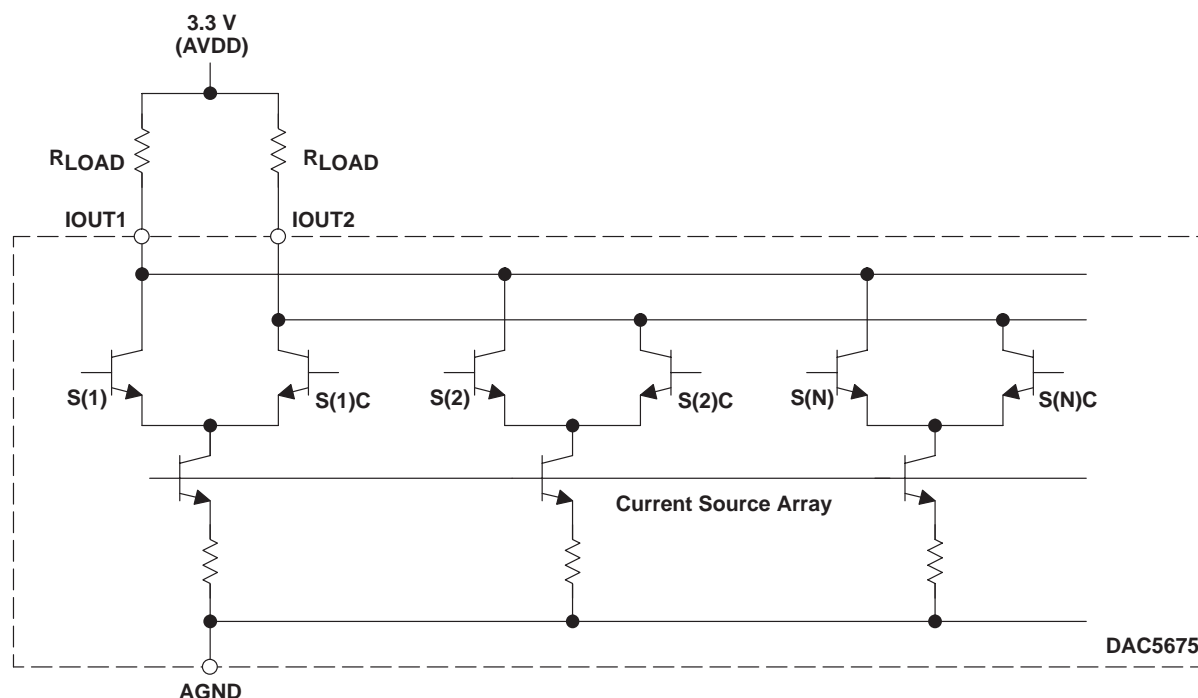

Figure 10. Equivalent Analog Current Output

analog current outputs (continued)

The DAC5675 can easily be configured to drive a doubly terminated 50-Ω cable using a properly selected transformer. Figure 11 and Figure 12 show the 1:1 and 4:1 impedance ratio configuration. These configurations provide maximum rejection of common-mode noise sources and even order distortion components, thereby doubling the DAC’s power to the output. The center tap on the primary side of the transformer is terminated to AVDD, enabling a dc current flow for both IOUT1 and IOUT2. Note that the ac performance of the DAC5675 is optimum and specified using a 1:1 differential transformer coupled output.

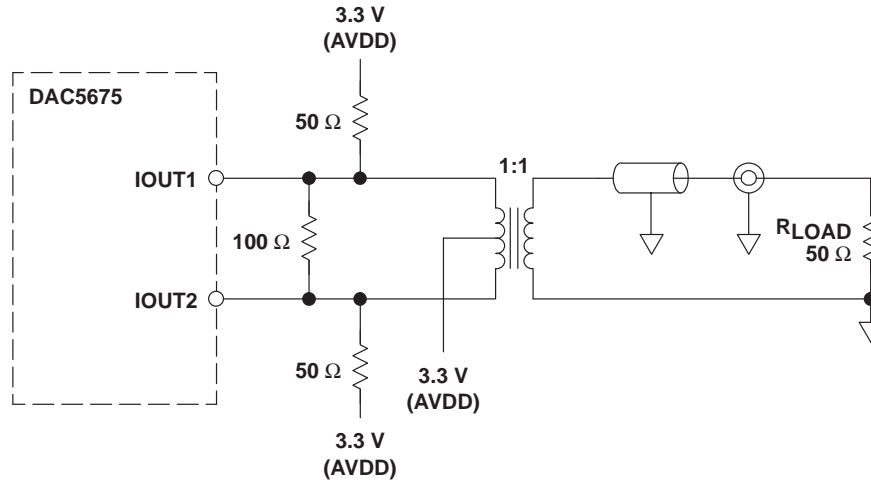

Figure 11. Driving a Doubly Terminated 50-Ω Cable Using a 1:1 Impedance Ratio Transformer

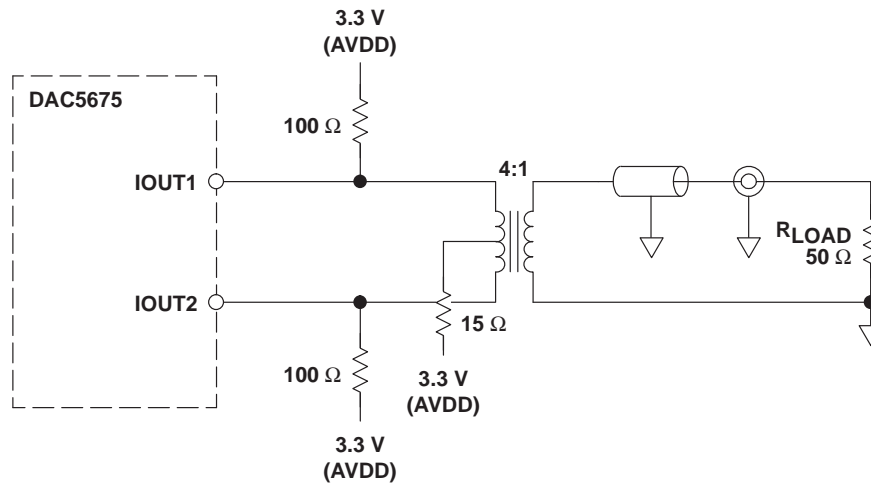

Figure 12. Driving a Doubly Terminated 50-Ω Cable Using a 4:1 Impedance Ratio Transformer

analog current outputs (continued)

Figure 13(a) shows the typical differential output configuration with two external matched resistor loads. The nominal resistor load of $25\ \Omega$ gives a differential output swing of $1\ V_{PP}$ ($0.5\ V_{PP}$ single-ended) when applying a 20-mA full-scale output current. The output impedance of the DAC5675 slightly depends on the output voltage at nodes IOOUT1 and IOOUT2. Consequently, for optimum dc-integral nonlinearity, the configuration of Figure 13(b) should be chosen. In this current/voltage (I-V) configuration, terminal IOOUT1 is kept at AVDD by the inverting operational amplifier. The complementary output should be connected to AVDD to provide a dc-current path for the current sources switched to IOOUT1. The amplifier's maximum output swing and the DACs full-scale output current determine the value of the feedback resistor (R_{FB}). The capacitor (C_{FB}) filters the steep edges of the DAC5675 current output, thereby reducing the operational amplifier's slew-rate requirements. In this configuration, the op amp should operate at a supply voltage higher than the resistors output reference voltage AVDD due to its positive and negative output swing around AVDD. Node IOOUT1 should be selected if a single-ended unipolar output is desired.

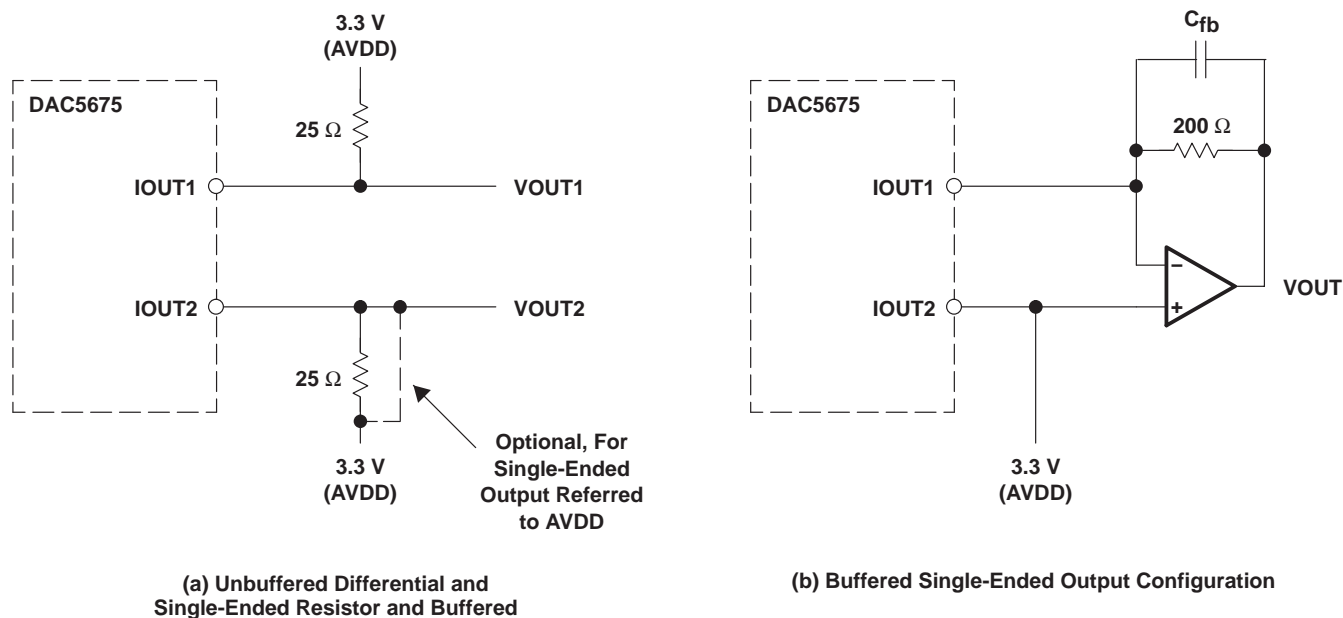

Figure 13. Output Configurations

sleep mode

The DAC5675 features a power-down mode that turns off the output current and reduces the supply current to approximately 45 mA. The power-down mode is activated by applying a logic level 1 to the SLEEP pin (e.g., by connecting the SLEEP pin to the AVDD pin). The SLEEP pin must be connected. Power-up and power-down activation times depend on the value of the external capacitor at node SLEEP. For a nominal capacitor value of $0.1\ \mu\text{F}$, powerdown takes less than $5\ \mu\text{s}$ and approximately 3 ms to power back up.

absolute maximum ratings over operating free-air temperature (unless otherwise noted)†

Supply voltage range: AV_{DD} ‡	-0.3 V to 3.6 V
DV_{DD} §	-0.3 V to 3.6 V
AV_{DD} to DV_{DD}	-3.6 V to 3.6 V
Voltage between AGND and DGND	-0.3 V to 0.5 V
CLK, CLKC, SLEEP§	-0.3 V to $DV_{DD} + 0.3$ V
Digital input D[13..0]A, D[13..0]B§	-0.3 V to $DV_{DD} + 0.3$ V
IOUT1, IOUT2‡	-1.0 V to $AV_{DD} + 0.3$ V
EXTIO, BIASJ‡	-0.3 V to $AV_{DD} + 0.3$ V
Peak input current (any input)	20 mA
Peak total input current (all inputs)	-30 mA
Operating free-air temperature range, T_A (DAC5675I)	-40°C to 85°C
Storage temperature range	-65°C to 150°C
Lead temperature 1,6 mm (1/16 inch) from the case for 10 seconds	260°C

† Stresses beyond those listed under “absolute maximum ratings” may cause permanent damage to the device. These are stress ratings only, and functional operation of the device at these or any other conditions beyond those indicated under “recommended operating conditions” is not implied. Exposure to absolute-maximum-rated conditions for extended periods may affect device reliability.

‡ Measured with respect to AGND

§ Measured with respect to DGND

recommended operating conditions

		MIN	TYP	MAX	UNIT
Output update rate	DLL disabled, DLLOFF = 1			100	MSPS
	DLL enabled, DLLOFF = 0(1)	100		400	
Analog supply voltage, AV_{DD}		3.15	3.3	3.6	V
Digital supply voltage, DV_{DD}		3.15	3.3	3.6	V
Input reference voltage, $V_{(EXTIO)}$		0.6	1.2	1.25	V
Full-scale output current, $I_{O(FS)}$		2		20	mA
Output compliance range	$AV_{DD} = 3.15$ to 3.45 V, $I_{O(FS)} = 20$ mA	$AV_{DD}-1$		$AV_{DD}+0.3$	V
Clock differential Input voltage, $ CLK-CLKC $		0.4		0.8	V
Clock pulse width high, $t_{w(H)}$			1.25		ns
Clock pulse width low, $t_{w(L)}$			1.25		ns
Clock duty cycle		40%		60%	
Operating free-air temperature, T_A		-40		85	°C

NOTE: 1. If changes to the main clock frequency or phase are initiated during operation, the DLL circuitry on the DAC5675 has a tendency to lose lock on the clock signal. When this situation occurs, the output data from the DAC5675 may be corrupted.

electrical characteristics over recommended operating free-air temperature range, $AV_{DD} = 3.3\text{ V}$, $DV_{DD} = 3.3\text{ V}$, $I_{O(FS)} = 20\text{ mA}$ (unless otherwise noted)

dc specifications

PARAMETER		TEST CONDITIONS	MIN	TYP	MAX	UNIT
Resolution			14			Bit
DC Accuracy (see Note 1)						
INL	Integral nonlinearity	T_{MIN} to T_{MAX}	-4	±2	4	LSB
DNL	Differential nonlinearity		-2	±1.5	2	
Monotonicity			Monotonic 12-b level			
Analog Output						
Offset error			0.02			%FSR
Gain error		Without internal reference	-10		10	%FSR
		With internal reference	-10		10	
Output resistance			300			k Ω
Output capacitance			5			pF
Reference Output						
$V_{(EXTIO)}$	Reference voltage		1.17	1.23	1.29	V
Reference output current (see Note 2)			100			nA
Reference Input						
Input resistance			1			M Ω
Small signal bandwidth			1.4			MHz
Input capacitance			100			pF
Temperature Coefficients						
Offset drift			0			ppm of FSR/ $^{\circ}\text{C}$
Gain drift		Without internal reference	±50			ppm of FSR/ $^{\circ}\text{C}$
		With internal reference	±100			
$\Delta V_{(EXTIO)}$	Reference voltage drift		±50			ppm/ $^{\circ}\text{C}$
Power Supply						
$I_{(AVDD)}$	Analog supply current (see Note 3)		175			mA
$I_{(DVDD)}$	Digital supply current (see Note 3)		100			mA
$I_{(AVDD)}$	Sleep mode supply current	Sleep mode	45			mA
P_D	Power dissipation (see Note 4)	$AV_{DD} = 3.3\text{ V}$, $DV_{DD} = 3.3\text{ V}$	820	900		mW
APSRR	Analog and digital power supply rejection ratio	$AV_{DD} = 3.15\text{ V}$ to 3.45 V	-0.5		0.5	%FSR/V
DPSSR			-0.5		0.5	

- NOTES: 1. Measured differential at IOUT1 and IOUT2. 2.5 Ω to AVDD
 2. Use an external buffer amplifier with high impedance input to drive any external load.
 3. Measured at $f_{CLK} = 400\text{ MSPS}$ and $f_{OUT} = 70\text{ MHz}$
 4. Measured for 50- Ω R_L at IOUT1 and IOUT2, $f_{CLK} = 400\text{ MSPS}$ and $f_{OUT} = 70\text{ MHz}$.

electrical characteristics over recommended operating free-air temperature range, $V_{DD} = 3.3\text{ V}$, $DV_{DD} = 3.3\text{ V}$, $I_{O(FS)} = 20\text{ mA}$, differential transformer coupled output, 50-Ω doubly terminated load (unless otherwise noted)

ac specifications

PARAMETER		TEST CONDITIONS	MIN	TYP	MAX	UNIT
Analog Output						
$t_s(\text{DAC})$	Output settling time to 0.1%	Transition: code x2000 to x23FF		12		ns
t_{pd}	Output propagation delay			1		ns
$t_r(\text{IOUT})$	Output rise time 10% to 90%			2		ns
$t_f(\text{IOUT})$	Output fall time 90% to 10%			2		ns
Output noise		$I_{O(FS)} = 20\text{ mA}$		55		$\text{pA}/\sqrt{\text{Hz}}$
		$I_{O(FS)} = 2\text{ mA}$		30		$\text{pA}/\sqrt{\text{Hz}}$
AC Linearity						
THD	Total harmonic distortion	$f_{\text{CLK}} = 100\text{ MSPS}$, $f_{\text{OUT}} = 20\text{ MHz}$, $T_A = 25^\circ\text{C}$		72		dBc
		$f_{\text{CLK}} = 160\text{ MSPS}$, $f_{\text{OUT}} = 41\text{ MHz}$, $T_A = 25^\circ\text{C}$		67		
		$f_{\text{CLK}} = 200\text{ MSPS}$, $f_{\text{OUT}} = 70\text{ MHz}$, $T_A = 25^\circ\text{C}$		63		
		$f_{\text{CLK}} = 400\text{ MSPS}$, $f_{\text{OUT}} = 20\text{ MHz}$, T_{MIN} to T_{MAX}		72		
		$f_{\text{CLK}} = 400\text{ MSPS}$, $f_{\text{OUT}} = 70\text{ MHz}$, $T_A = 25^\circ\text{C}$		64		
		$f_{\text{CLK}} = 400\text{ MSPS}$, $f_{\text{OUT}} = 140\text{ MHz}$, $T_A = 25^\circ\text{C}$		58		
SFDR	Spurious free dynamic range to Nyquist	$f_{\text{CLK}} = 100\text{ MSPS}$, $f_{\text{OUT}} = 20\text{ MHz}$, $T_A = 25^\circ\text{C}$		77		dBc
		$f_{\text{CLK}} = 160\text{ MSPS}$, $f_{\text{OUT}} = 41\text{ MHz}$, $T_A = 25^\circ\text{C}$		70		
		$f_{\text{CLK}} = 200\text{ MSPS}$, $f_{\text{OUT}} = 70\text{ MHz}$, $T_A = 25^\circ\text{C}$		70		
		$f_{\text{CLK}} = 400\text{ MSPS}$, $f_{\text{OUT}} = 20\text{ MHz}$, T_{MIN} to T_{MAX}		73		
		$f_{\text{CLK}} = 400\text{ MSPS}$, $f_{\text{OUT}} = 70\text{ MHz}$, $T_A = 25^\circ\text{C}$		69		
		$f_{\text{CLK}} = 400\text{ MSPS}$, $f_{\text{OUT}} = 140\text{ MHz}$, $T_A = 25^\circ\text{C}$		58		
SFDR	Spurious free dynamic range within a window, 5-MHz span	$f_{\text{CLK}} = 100\text{ MSPS}$, $f_{\text{OUT}} = 20\text{ MHz}$, $T_A = 25^\circ\text{C}$		88		dBc
		$f_{\text{CLK}} = 160\text{ MSPS}$, $f_{\text{OUT}} = 41\text{ MHz}$, $T_A = 25^\circ\text{C}$		83		
		$f_{\text{CLK}} = 200\text{ MSPS}$, $f_{\text{OUT}} = 70\text{ MHz}$, $T_A = 25^\circ\text{C}$		80		
		$f_{\text{CLK}} = 400\text{ MSPS}$, $f_{\text{OUT}} = 20\text{ MHz}$, T_{MIN} to T_{MAX}		88		
		$f_{\text{CLK}} = 400\text{ MSPS}$, $f_{\text{OUT}} = 70\text{ MHz}$, $T_A = 25^\circ\text{C}$		80		
		$f_{\text{CLK}} = 400\text{ MSPS}$, $f_{\text{OUT}} = 140\text{ MHz}$, $T_A = 25^\circ\text{C}$		73		
ACPR	Adjacent channel power ratio WCDMA with 3.84 MHz BW, 5-MHz channel spacing†	$f_{\text{CLK}} = 122.88\text{ MSPS}$, $\text{IF} = 30.72\text{ MHz}$, $T_A = 25^\circ\text{C}$ (See Figure 14)		73		dB
		$f_{\text{CLK}} = 245.76\text{ MSPS}$, $\text{IF} = 61.44\text{ MHz}$, $T_A = 25^\circ\text{C}$ (See Figure 15)		71		dB
		$f_{\text{CLK}} = 399.32\text{ MSPS}$, $\text{IF} = 153.36\text{ MHz}$, $T_A = 25^\circ\text{C}$ (See Figure 17)		68		dB
IMD	Two-tone intermodulation to Nyquist (each tone at -6 dBFS)	$f_{\text{CLK}} = 400\text{ MSPS}$, $f_{\text{OUT}1} = 70\text{ MHz}$, $f_{\text{OUT}2} = 71\text{ MHz}$, $T_A = 25^\circ\text{C}$		67		dBc
		$f_{\text{CLK}} = 400\text{ MSPS}$, $f_{\text{OUT}1} = 140\text{ MHz}$, $f_{\text{OUT}2} = 141\text{ MHz}$, $T_A = 25^\circ\text{C}$		63		
	Four-tone intermodulation, 15-MHz span, missing center tone (each tone at -16 dBFS)	$f_{\text{CLK}} = 156\text{ MSPS}$, $f_{\text{OUT}} = 15.6, 15.8, 16.2, 16.4\text{ MHz}$		72		dBc
		$f_{\text{CLK}} = 400\text{ MSPS}$, $f_{\text{OUT}} = 68.1, 69.3, 71.2, 72\text{ MHz}$		74		

† Spectrum analyzer (ACPR) performance taken into account for the calculation of the DAC5675 ACPR performance.

electrical characteristics over recommended operating free-air temperature range, $V_{DD} = 3.3\text{ V}$, $DV_{DD} = 3.3\text{ V}$ (unless otherwise noted)

digital specifications

PARAMETER	TEST CONDITIONS	MIN	TYP	MAX	UNIT
LVDS Interface: nodes D[13..0]A, D[13..0]B					
V_{ITH+}	Positive-going differential input voltage threshold	See LVDS min/max threshold voltages table		100	mV
V_{ITH-}	Negative-going differential input voltage threshold			-100	
Z_T	Internal termination impedance	90		132	Ω
C_I	Input capacitance			2	pF
CMOS interface: node SLEEP					
V_{IH}	High-level input voltage	2	3.3		V
V_{IL}	Low-level input voltage		0	0.8	V
I_{IH}	High-level input current	-10		10	μA
I_{IL}	Low-level input current	-10		10	μA
	Input capacitance			2	pF
Clock interface: node CLK, CLKC					
	Input resistance	Node CLK, CLKC		670	Ω
	Input capacitance	Node CLK, CLKC		2	pF
	Input resistance	Differential		1.3	k Ω
	Input capacitance	Differential		1	pF
Timing					
t_{su}	Input setup time			1.5	ns
t_h	Input hold time			0.25	ns
t_{LPH}	Input latch pulse high time			2	ns
t_{DD}	Digital delay time			1	clk

electrical characteristics over recommended operating free-air temperature range, $AV_{DD} = 3.3\text{ V}$, $DV_{DD} = 3.3\text{ V}$, $I_{O(FS)} = 20\text{ mA}$ (unless otherwise noted)

LVDS input minimum and maximum input threshold and logical bit equivalent

APPLIED VOLTAGES		RESULTING DIFFERENTIAL INPUT VOLTAGE	RESULTING COMMON-MODE INPUT VOLTAGE	LOGICAL BIT BINARY EQUIVALENT	COMMENT
V_A [V]	V_B [V]	$V_{A,B}$ [mV]	V_{COM} [V]		
1.25	1.15	200	1.2	1	Operation with minimum differential voltage ($\pm 200\text{ mV}$) applied to the complementary inputs versus common mode range
1.15	1.25	-200	1.2	0	
2.4	2.3	200	2.35	1	
2.3	2.4	-200	2.35	0	
0.1	0	200	0.05	1	
0	0.1	-200	0.05	0	
1.5	0.9	600	1.2	1	Operation with maximum differential voltage ($\pm 600\text{ mV}$) applied to the complementary inputs versus common mode range
0.9	1.5	-600	1.2	0	
2.4	1.8	600	2.1	1	
1.8	2.4	-600	2.1	0	
0.6	0	600	0.3	1	
0	0.6	-600	0.3	0	

Specifications subject to change

TYPICAL CHARACTERISTICS

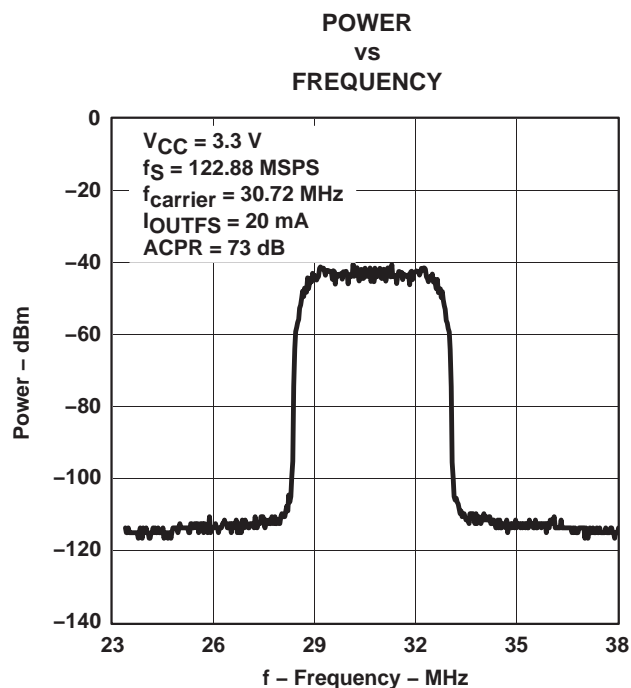

Figure 14

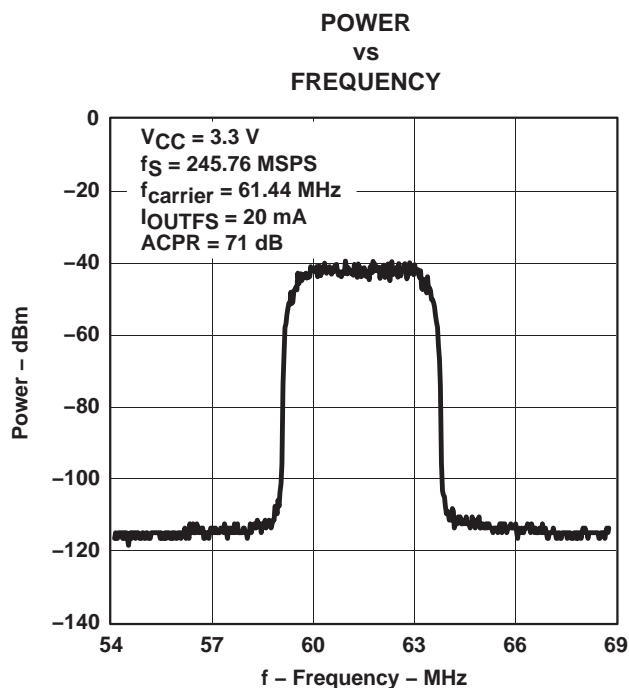

Figure 15

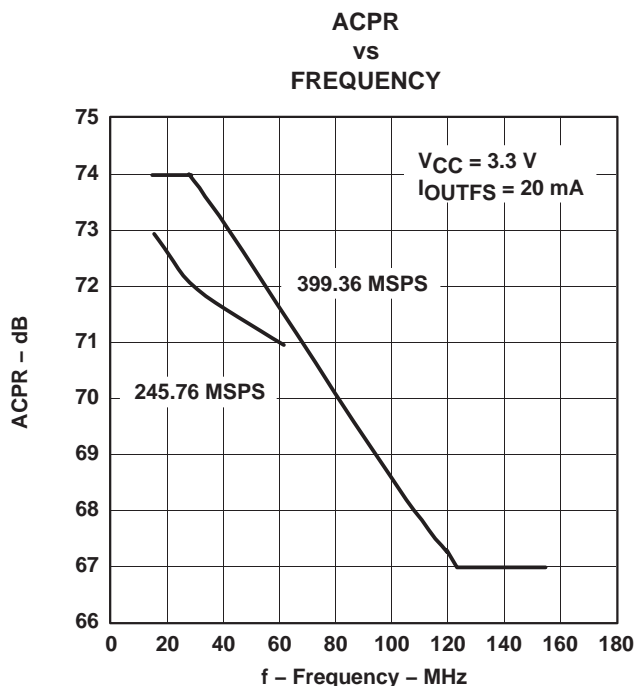

Figure 16

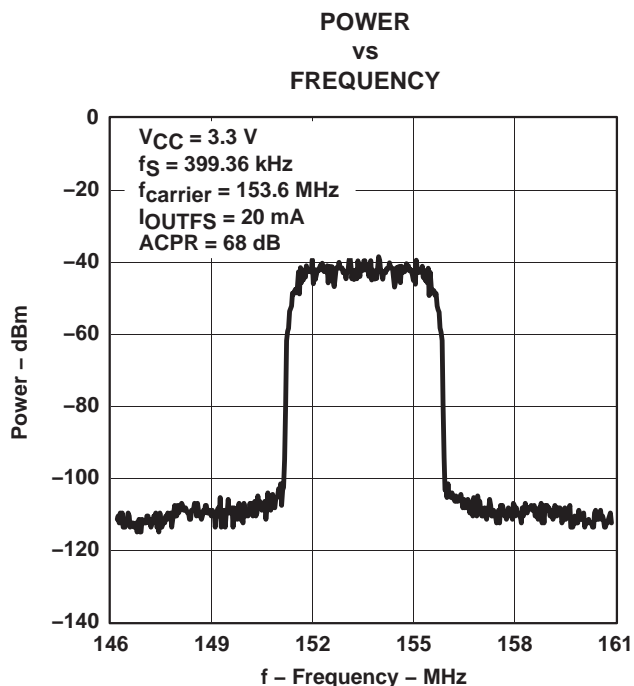

Figure 17

TYPICAL CHARACTERISTICS

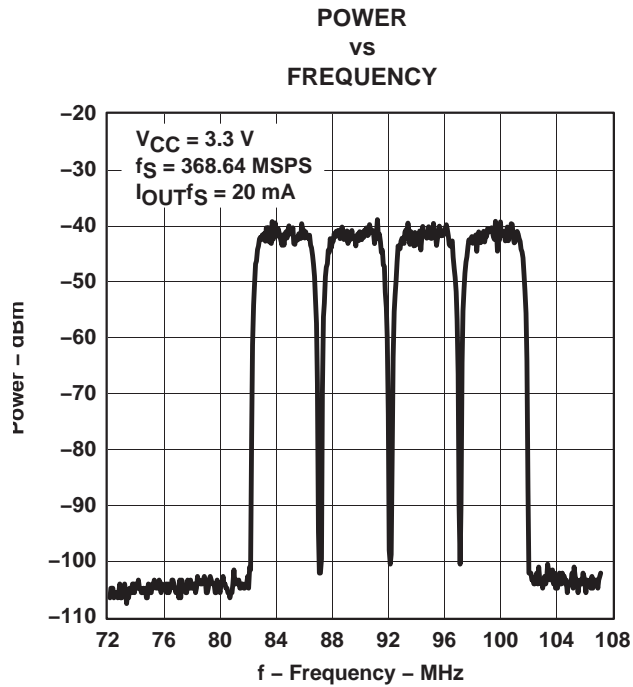

Figure 18

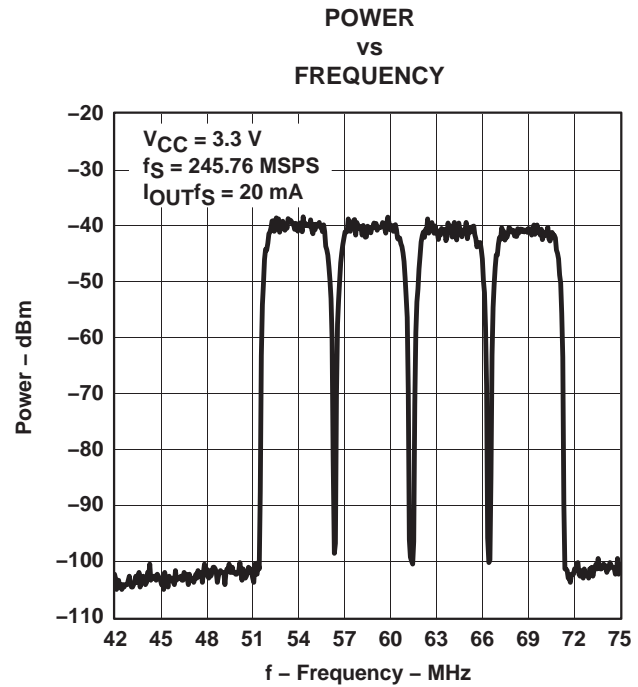

Figure 19

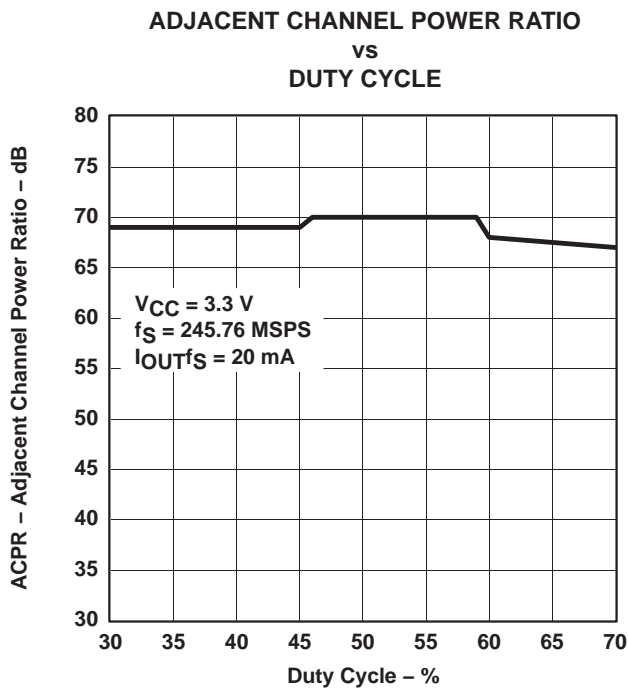

Figure 20

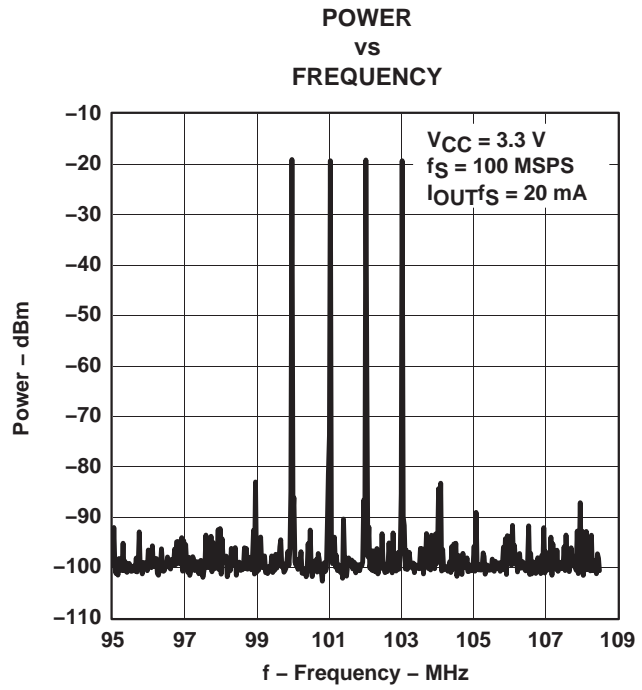

Figure 21

TYPICAL CHARACTERISTICS

INTEGRAL NONLINEARITY
vs
INPUT CODE

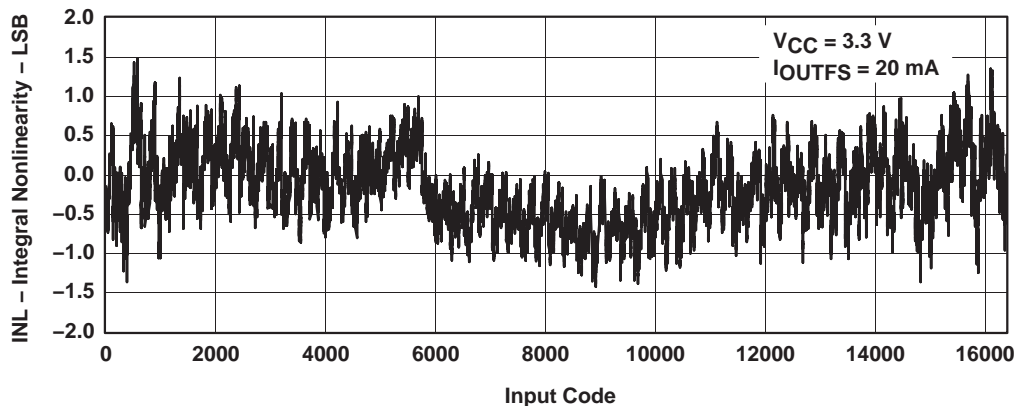

Figure 22

DIFFERENTIAL NONLINEARITY
vs
INPUT CODE

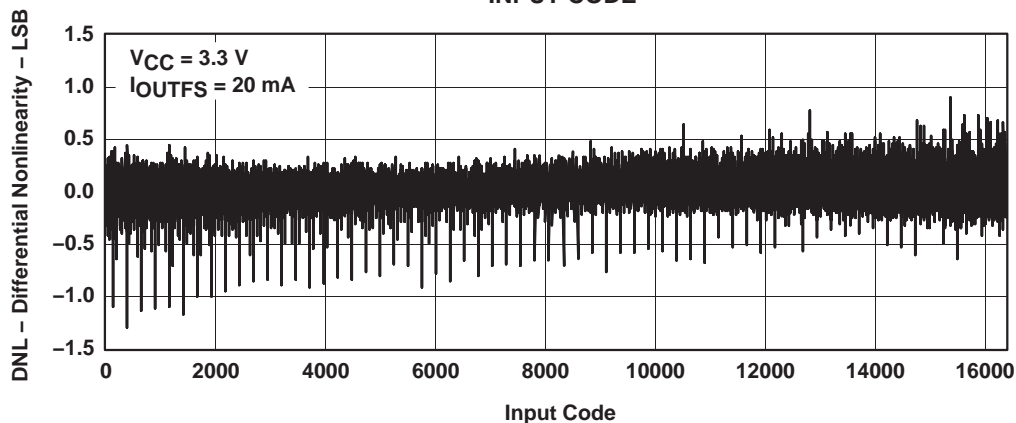

Figure 23

TYPICAL CHARACTERISTICS

SPURIOUS-FREE DYNAMIC RANGE
vs
OUTPUT FREQUENCY

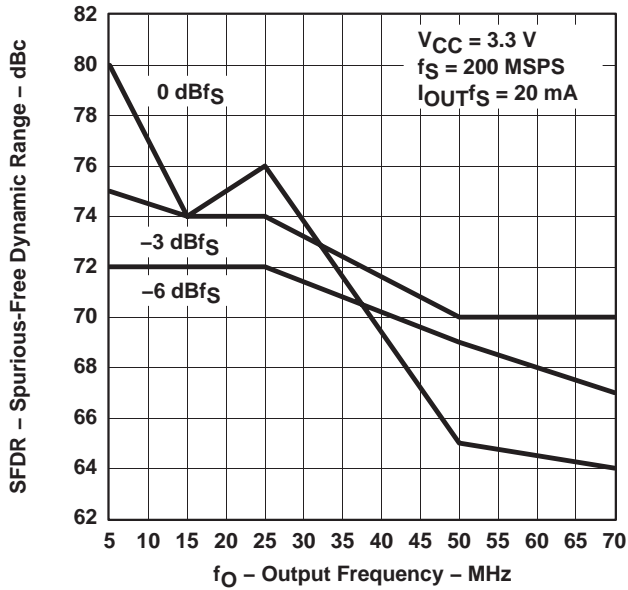

Figure 24

SPURIOUS-FREE DYNAMIC RANGE
vs
OUTPUT FREQUENCY

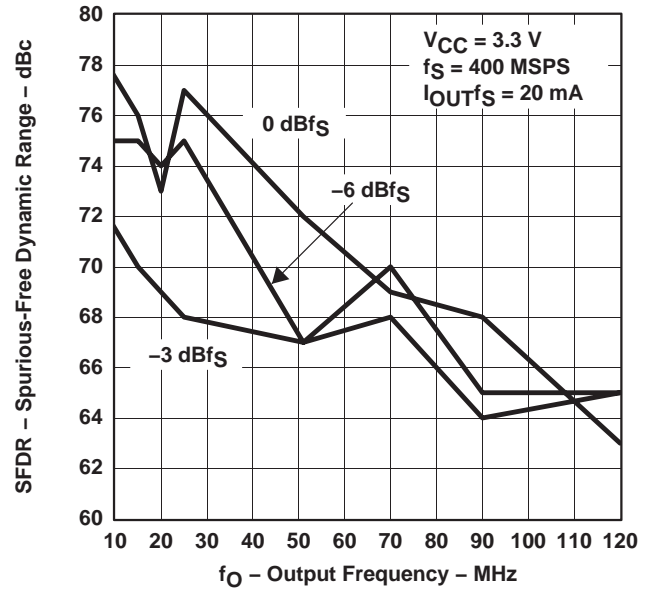

Figure 25

POWER DISSIPATION
vs
SAMPLING FREQUENCY

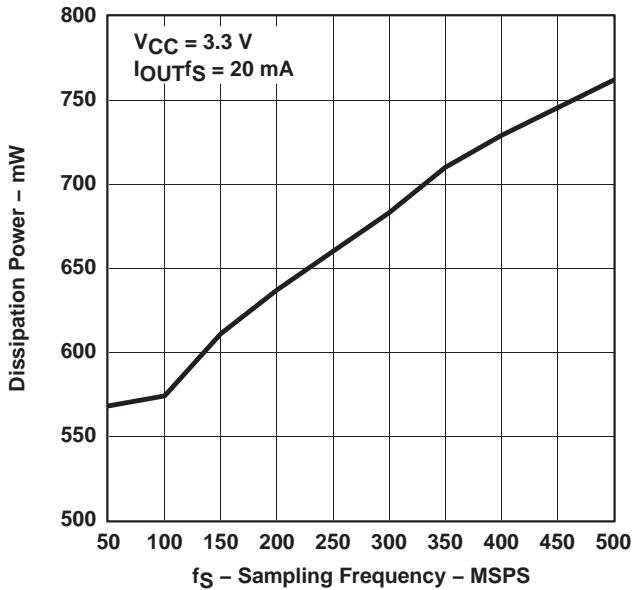

Figure 26

INTERMODULATION
vs
INPUT FREQUENCY

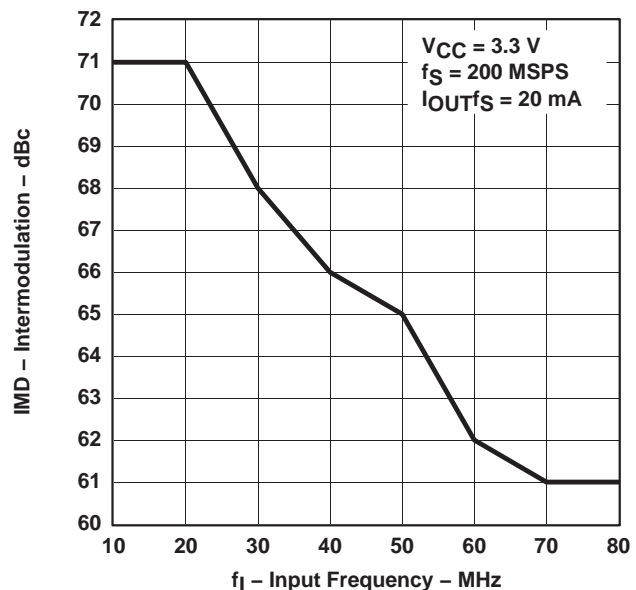

Figure 27

TYPICAL CHARACTERISTICS

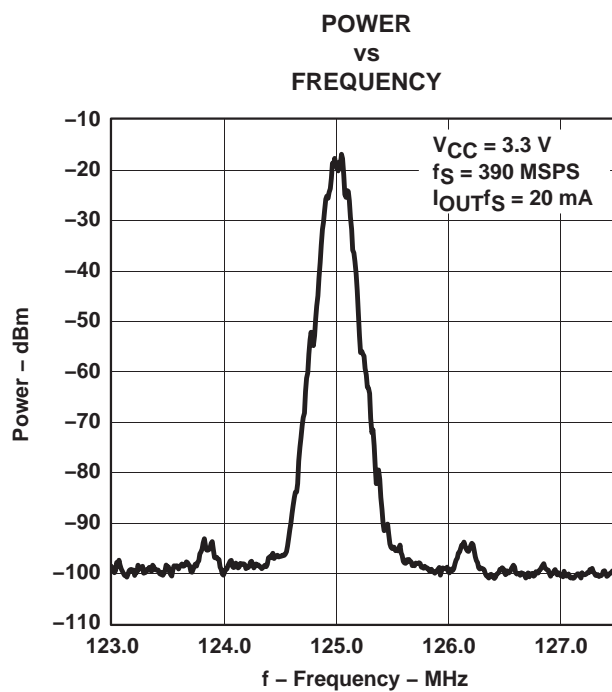

Figure 28

DEFINITIONS

definitions of specifications and terminology

Gain error is defined as the percentage error in the ratio between the measured full-scale output current and the value of $16 \times V_{(EXTIO)}/R_{BIAS}$. A $V_{(EXTIO)}$ of 1.25 V is used to measure the gain error with external reference voltage applied. With internal reference, this error includes the deviation of $V_{(EXTIO)}$ (internal bandgap reference voltage) from the typical value of 1.25 V.

Offset error is defined as the percentage error in the ratio of the differential output current ($I_{OUT1}-I_{OUT2}$) and the half of the full-scale output current for input code 8192.

THD is the ratio of the rms sum of the first six harmonic components to the rms value of the fundamental output signal.

SNR is the ratio of the rms value of the fundamental output signal to the rms sum of all other spectral components below the Nyquist frequency, including noise, but excluding the first six harmonics and dc.

SINAD is the ratio of the rms value of the fundamental output signal to the rms sum of all other spectral components below the Nyquist frequency, including noise and harmonics, but excluding dc.

ACPR or adjacent channel power ratio is defined for a 3.84 Mcps 3GPP W-CDMA input signal measured in a 3.9-MHz bandwidth at a 5-MHz offset from the carrier with a 12-dB peak-to-average ratio.

APSSR or analog power supply ratio is the percentage variation of full-scale output current versus a 5% variation of the analog power supply AVDD from the nominal. This is a dc measurement.

DPSSR or digital power supply ratio is the percentage variation of full-scale output current versus a 5% variation of the digital power supply DVDD from the nominal. This is a dc measurement.

DAC5675 evaluation board

An EVM (evaluation module) board for the DAC5675 digital-to-analog converter is available for evaluation. This board allows the user the flexibility to operate the DAC5675 in various configurations. The digital inputs are designed to be driven either directly from various pattern generators and or from LVDS bus drivers.

PACKAGING INFORMATION

Orderable Device	Status (1)	Package Type	Package Drawing	Pins	Package Qty	Eco Plan (2)	Lead/Ball Finish (6)	MSL Peak Temp (3)	Op Temp (°C)	Device Marking (4/5)	Samples
DAC56751PHP	NRND	HTQFP	PHP	48	250	Green (RoHS & no Sb/Br)	CU NIPDAU	Level-3-260C-168 HR	-40 to 85	DAC5675I	

(1) The marketing status values are defined as follows:

ACTIVE: Product device recommended for new designs.

LIFEBUY: TI has announced that the device will be discontinued, and a lifetime-buy period is in effect.

NRND: Not recommended for new designs. Device is in production to support existing customers, but TI does not recommend using this part in a new design.

PREVIEW: Device has been announced but is not in production. Samples may or may not be available.

OBSELETE: TI has discontinued the production of the device.

(2) Eco Plan - The planned eco-friendly classification: Pb-Free (RoHS), Pb-Free (RoHS Exempt), or Green (RoHS & no Sb/Br) - please check <http://www.ti.com/productcontent> for the latest availability information and additional product content details.

TBD: The Pb-Free/Green conversion plan has not been defined.

Pb-Free (RoHS): TI's terms "Lead-Free" or "Pb-Free" mean semiconductor products that are compatible with the current RoHS requirements for all 6 substances, including the requirement that lead not exceed 0.1% by weight in homogeneous materials. Where designed to be soldered at high temperatures, TI Pb-Free products are suitable for use in specified lead-free processes.

Pb-Free (RoHS Exempt): This component has a RoHS exemption for either 1) lead-based flip-chip solder bumps used between the die and package, or 2) lead-based die adhesive used between the die and leadframe. The component is otherwise considered Pb-Free (RoHS compatible) as defined above.

Green (RoHS & no Sb/Br): TI defines "Green" to mean Pb-Free (RoHS compatible), and free of Bromine (Br) and Antimony (Sb) based flame retardants (Br or Sb do not exceed 0.1% by weight in homogeneous material)

(3) MSL, Peak Temp. - The Moisture Sensitivity Level rating according to the JEDEC industry standard classifications, and peak solder temperature.

(4) There may be additional marking, which relates to the logo, the lot trace code information, or the environmental category on the device.

(5) Multiple Device Markings will be inside parentheses. Only one Device Marking contained in parentheses and separated by a "~" will appear on a device. If a line is indented then it is a continuation of the previous line and the two combined represent the entire Device Marking for that device.

(6) Lead/Ball Finish - Orderable Devices may have multiple material finish options. Finish options are separated by a vertical ruled line. Lead/Ball Finish values may wrap to two lines if the finish value exceeds the maximum column width.

Important Information and Disclaimer:The information provided on this page represents TI's knowledge and belief as of the date that it is provided. TI bases its knowledge and belief on information provided by third parties, and makes no representation or warranty as to the accuracy of such information. Efforts are underway to better integrate information from third parties. TI has taken and continues to take reasonable steps to provide representative and accurate information but may not have conducted destructive testing or chemical analysis on incoming materials and chemicals. TI and TI suppliers consider certain information to be proprietary, and thus CAS numbers and other limited information may not be available for release.

In no event shall TI's liability arising out of such information exceed the total purchase price of the TI part(s) at issue in this document sold by TI to Customer on an annual basis.

OTHER QUALIFIED VERSIONS OF DAC5675 :

- Enhanced Product: [DAC5675-EP](#)

NOTE: Qualified Version Definitions:

- Enhanced Product - Supports Defense, Aerospace and Medical Applications

PHP (S-PQFP-G48)

PowerPAD™ PLASTIC QUAD FLATPACK

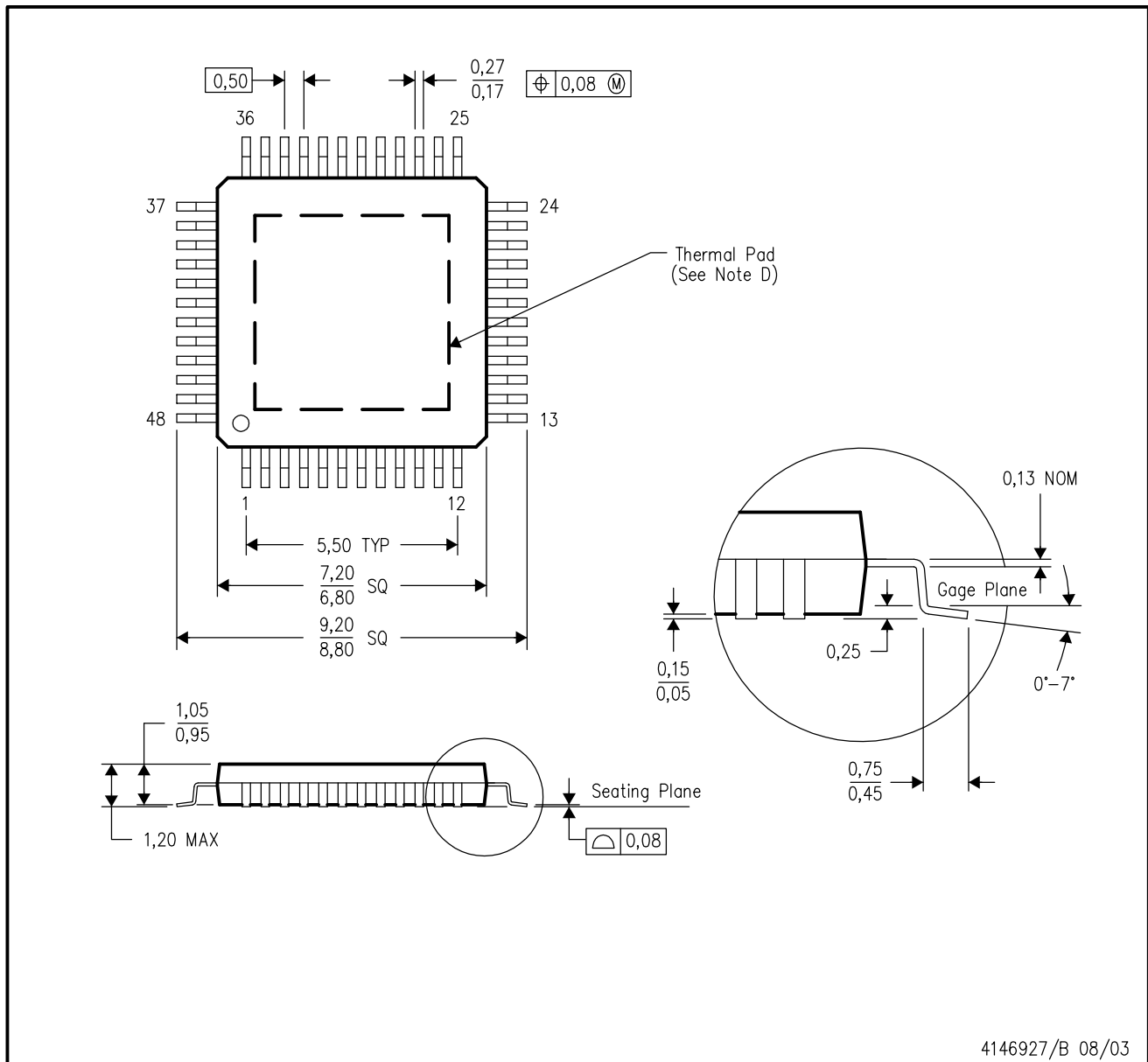

- NOTES:
- All linear dimensions are in millimeters.
 - This drawing is subject to change without notice.
 - Body dimensions do not include mold flash or protrusion
 - This package is designed to be soldered to a thermal pad on the board. Refer to Technical Brief, PowerPad Thermally Enhanced Package, Texas Instruments Literature No. SLMA002 for information regarding recommended board layout. This document is available at www.ti.com <<http://www.ti.com>>.
 - Falls within JEDEC MS-026

PowerPAD is a trademark of Texas Instruments.

THERMAL PAD MECHANICAL DATA

PHP (S-PQFP-G48)

PowerPAD™ PLASTIC QUAD FLATPACK

THERMAL INFORMATION

This PowerPAD™ package incorporates an exposed thermal pad that is designed to be attached to a printed circuit board (PCB). The thermal pad must be soldered directly to the PCB. After soldering, the PCB can be used as a heatsink. In addition, through the use of thermal vias, the thermal pad can be attached directly to the appropriate copper plane shown in the electrical schematic for the device, or alternatively, can be attached to a special heatsink structure designed into the PCB. This design optimizes the heat transfer from the integrated circuit (IC).

For additional information on the PowerPAD package and how to take advantage of its heat dissipating abilities, refer to Technical Brief, PowerPAD Thermally Enhanced Package, Texas Instruments Literature No. SLMA002 and Application Brief, PowerPAD Made Easy, Texas Instruments Literature No. SLMA004. Both documents are available at www.ti.com.

The exposed thermal pad dimensions for this package are shown in the following illustration.

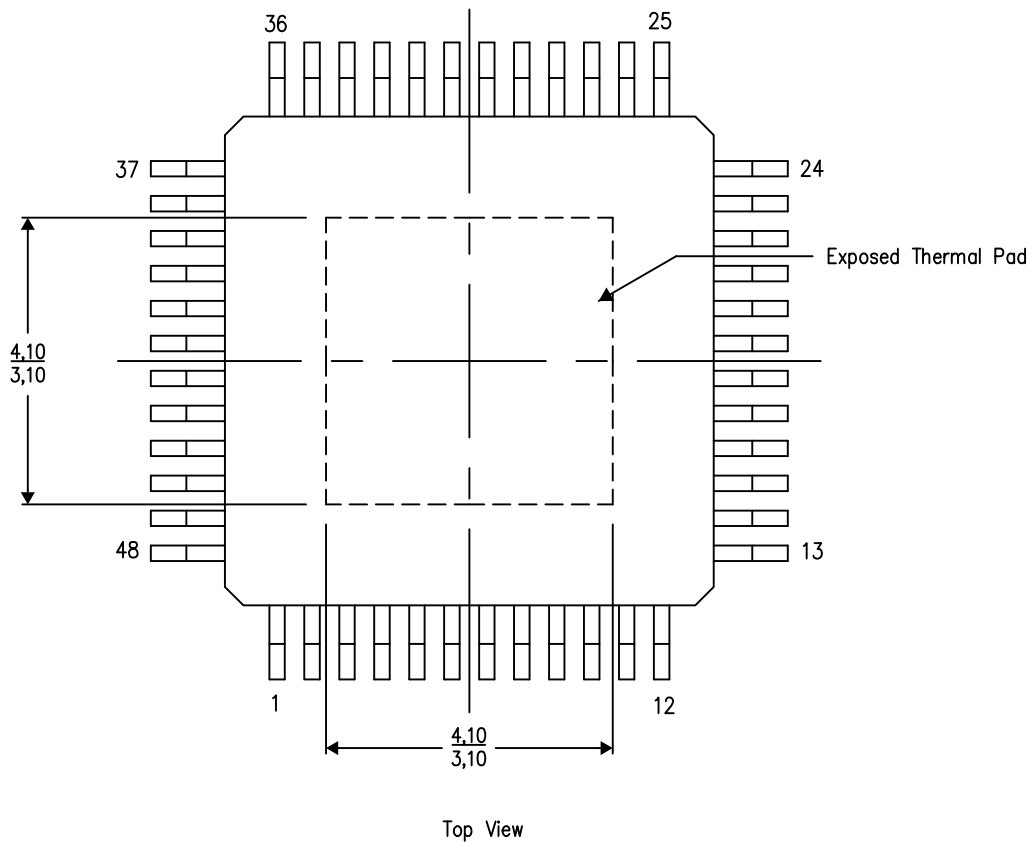

Exposed Thermal Pad Dimensions

4206329-3/P 03/15

NOTE: A. All linear dimensions are in millimeters

PowerPAD is a trademark of Texas Instruments

PHP (S-PQFP-G48)

PowerPAD™ PLASTIC QUAD FLATPACK

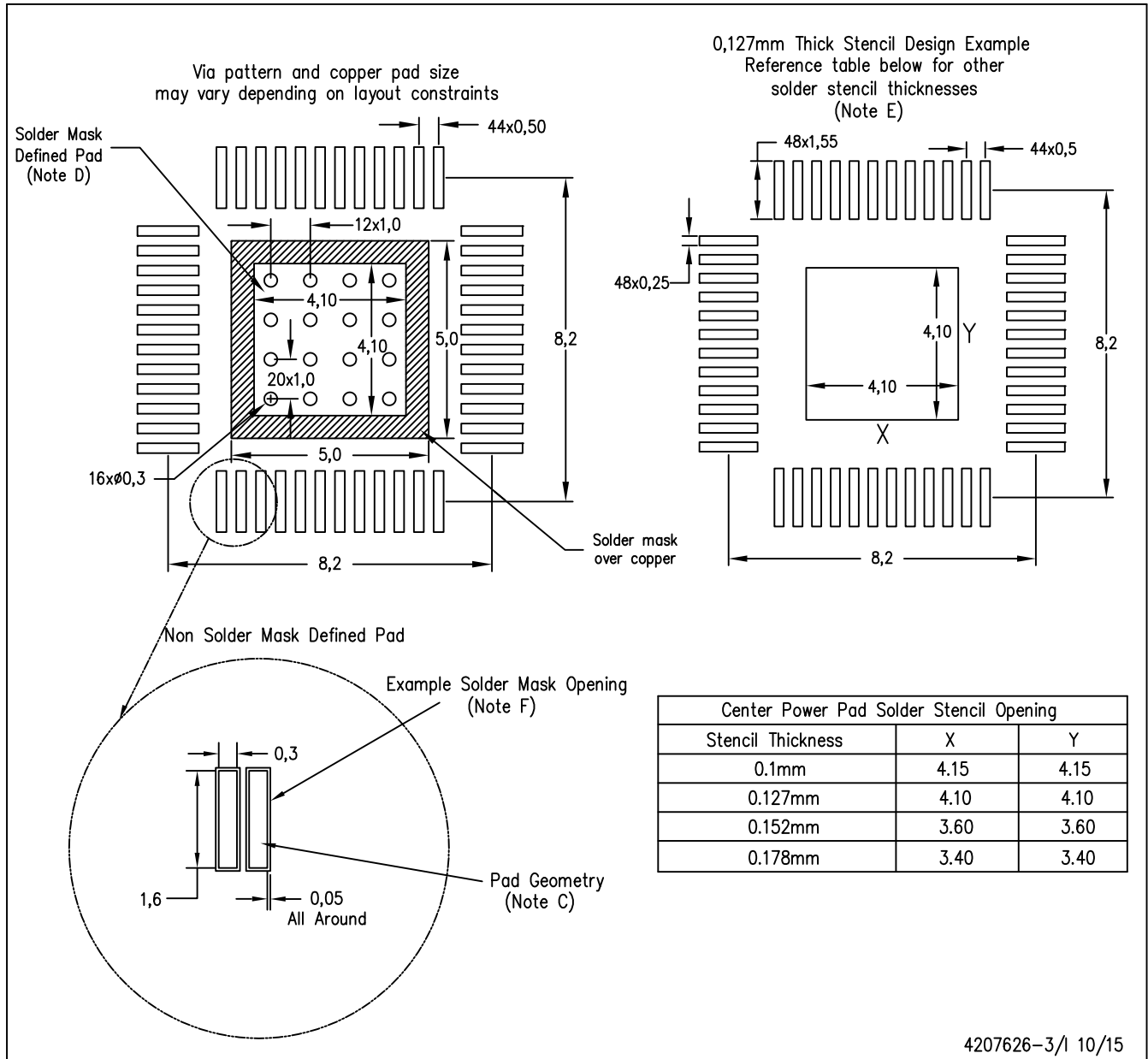

- NOTES:
- A. All linear dimensions are in millimeters.
 - B. This drawing is subject to change without notice.
 - C. Publication IPC-7351 is recommended for alternate designs.
 - D. This package is designed to be soldered to a thermal pad on the board. Refer to Technical Brief, PowerPAD Thermally Enhanced Package, Texas Instruments Literature No. SLMA002, SLMA004, and also the Product Data Sheets for specific thermal information, via requirements, and recommended board layout. These documents are available at www.ti.com <<http://www.ti.com>>.
 - E. Laser cutting apertures with trapezoidal walls and also rounding corners will offer better paste release. Customers should contact their board assembly site for stencil design recommendations. Refer to IPC 7525 for stencil design considerations.
 - F. Customers should contact their board fabrication site for recommended solder mask tolerances and via tenting options for vias placed in the thermal pad.

PowerPAD is a trademark of Texas Instruments

IMPORTANT NOTICE AND DISCLAIMER

TI PROVIDES TECHNICAL AND RELIABILITY DATA (INCLUDING DATASHEETS), DESIGN RESOURCES (INCLUDING REFERENCE DESIGNS), APPLICATION OR OTHER DESIGN ADVICE, WEB TOOLS, SAFETY INFORMATION, AND OTHER RESOURCES "AS IS" AND WITH ALL FAULTS, AND DISCLAIMS ALL WARRANTIES, EXPRESS AND IMPLIED, INCLUDING WITHOUT LIMITATION ANY IMPLIED WARRANTIES OF MERCHANTABILITY, FITNESS FOR A PARTICULAR PURPOSE OR NON-INFRINGEMENT OF THIRD PARTY INTELLECTUAL PROPERTY RIGHTS.

These resources are intended for skilled developers designing with TI products. You are solely responsible for (1) selecting the appropriate TI products for your application, (2) designing, validating and testing your application, and (3) ensuring your application meets applicable standards, and any other safety, security, or other requirements. These resources are subject to change without notice. TI grants you permission to use these resources only for development of an application that uses the TI products described in the resource. Other reproduction and display of these resources is prohibited. No license is granted to any other TI intellectual property right or to any third party intellectual property right. TI disclaims responsibility for, and you will fully indemnify TI and its representatives against, any claims, damages, costs, losses, and liabilities arising out of your use of these resources.

TI's products are provided subject to TI's Terms of Sale (www.ti.com/legal/termsofsale.html) or other applicable terms available either on ti.com or provided in conjunction with such TI products. TI's provision of these resources does not expand or otherwise alter TI's applicable warranties or warranty disclaimers for TI products.

Mailing Address: Texas Instruments, Post Office Box 655303, Dallas, Texas 75265
Copyright © 2019, Texas Instruments Incorporated

Looking for pricing, stock, or lifecycle information?

Click below to explore more details on WIN SOURCE:

 [View DAC5675IPHPG4](#) on WIN SOURCE

 [Texas Instruments](#) Information

Optimize Your Supply Chain with WIN SOURCE Solutions

-  Global Sourcing Solution
-  Obsolete Management
-  Cost Control Management
-  Shortage Management
-  Alternative Solution
-  Excess Inventory Management