



**THE DATASHEET OF
DAC104S085CIMMX/NOPB**



DAC104S085-xx 10-Bit Micro Power QUAD Digital-to-Analog Converter With Rail-to-Rail Output

1 Features

- Qualified for Automotive Applications
- AEC-Q100 Qualified With the Following Results:
 - Device Temperature Grade 1: -40°C to 125°C Ambient Operating Temperature
- Ensured Monotonicity
- Low Power Operation
- Rail-to-Rail Voltage Output
- Power-On Reset to 0 V
- Simultaneous Output Updating
- Wide Power Supply Range (2.7 V to 5.5 V)
- Key Specifications
 - Resolution: 10 bits
 - INL: ± 2 LSB (Maximum)
 - DNL: $+0.35 / -0.25$ LSB (Maximum)
 - Settling Time: 6 μs (Maximum)
 - Zero Code Error: 15 mV (Maximum)
 - Full-Scale Error: -0.75% FS (Maximum)
 - Typical Supply Power
 - Normal Mode: 1.1 mW (3 V), 2.5 mW (5 V)
 - Power Down: 0.3 μW (3 V), 0.8 μW (5 V)

2 Applications

- Battery-Powered Instruments
- Digital Gain and Offset Adjustment
- Programmable Voltage and Current Sources
- Programmable Attenuators
- Automotives

3 Description

The DAC104S085 device is a full-featured, general-purpose QUAD 10-bit voltage-output digital-to-analog converter (DAC) that can operate from a single 2.7-V to 5.5-V supply and consumes 1.1 mW at 3 V and 2.5 mW at 5 V. The DAC104S085 is packaged in 10-pin SON and VSSOP packages. The 10-pin SON package makes the DAC104S085 the smallest QUAD DAC in its class. The on-chip output amplifier allows rail-to-rail output swing and the three wire serial interface operates at clock rates up to 40 MHz over the entire supply voltage range. Competitive devices are limited to 25-MHz clock rates at supply voltages in the 2.7-V to 3.6-V range. The serial interface is compatible with standard SPI, QSPI, MICROWIRE, and DSP interfaces.

The reference for the DAC104S085 serves all four channels and can vary in voltage between 1 V and V_A , providing the widest possible output dynamic range. The DAC104S085 has a 16-bit input shift register that controls the outputs to be updated, the mode of operation, the power-down condition, and the binary input data. All four outputs can be updated simultaneously or individually depending on the setting of the two mode of operation bits.

Device Information⁽¹⁾

PART NUMBER	PACKAGE	BODY SIZE (NOM)
DAC104S085-xx	VSSOP (10)	3.00 mm x 3.00 mm
	WSON (10)	3.00 mm x 3.00 mm

(1) For all available packages, see the orderable addendum at the end of the data sheet.

Block Diagram

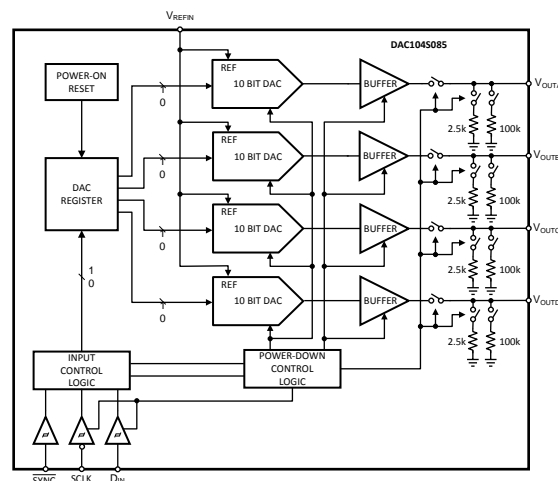

Copyright © 2016, Texas Instruments Incorporated



Table of Contents

1	Features	1	8.3	Feature Description.....	14
2	Applications	1	8.4	Device Functional Modes.....	15
3	Description	1	8.5	Programming.....	16
4	Revision History	2	9	Application and Implementation	19
5	Description (continued)	3	9.1	Application Information.....	19
6	Pin Configuration and Functions	3	9.2	Typical Application	21
7	Specifications	4	10	Power Supply Recommendations	22
7.1	Absolute Maximum Ratings	4	11	Layout	23
7.2	ESD Ratings – DAC104S085	4	11.1	Layout Guidelines	23
7.3	ESD Ratings – DAC104S085-Q1	4	11.2	Layout Example	23
7.4	Recommended Operating Conditions	4	12	Device and Documentation Support	24
7.5	Thermal Information	5	12.1	Device Support.....	24
7.6	Electrical Characteristics.....	5	12.2	Related Links	25
7.7	Timing Requirements	7	12.3	Community Resources.....	25
7.8	Typical Characteristics	9	12.4	Trademarks	25
8	Detailed Description	13	12.5	Electrostatic Discharge Caution.....	25
8.1	Overview	13	12.6	Glossary	25
8.2	Functional Block Diagram	14	13	Mechanical, Packaging, and Orderable Information	25

4 Revision History

NOTE: Page numbers for previous revisions may differ from page numbers in the current version.

Changes from Revision F (March 2013) to Revision G

Page

- Added *ESD Ratings* table, *Feature Description* section, *Device Functional Modes*, *Application and Implementation* section, *Power Supply Recommendations* section, *Layout* section, *Device and Documentation Support* section, and *Mechanical, Packaging, and Orderable Information* section. **1**

Changes from Revision E (March 2013) to Revision F

Page

- Changed layout of National Data Sheet to TI format

5 Description (continued)

A power-on reset circuit ensures that the DAC output powers up to zero volts and remains there until there is a valid write to the device. A power-down feature reduces power consumption to less than a microWatt with three different termination options.

The low power consumption and small packages of the DAC104S085 make it an excellent choice for use in battery-operated equipment.

The DAC104S085 is one of a family of pin-compatible DACs, including the 8-bit DAC084S085 and the 12-bit DAC124S085. The DAC104S085 operates over the extended industrial temperature range of -40°C to $+125^{\circ}\text{C}$.

6 Pin Configuration and Functions

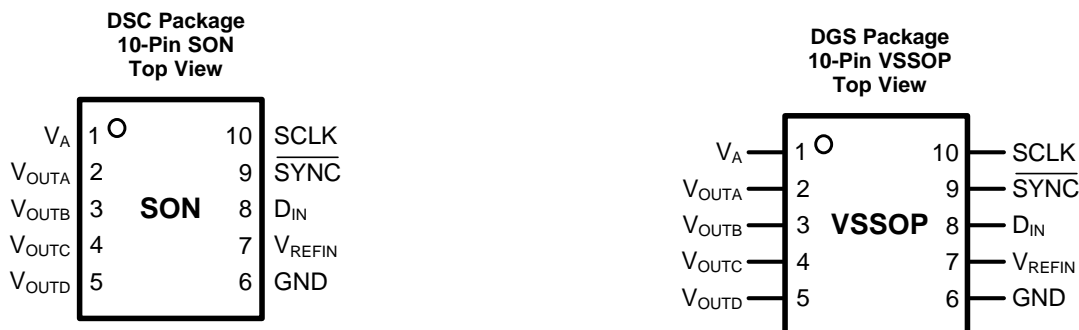

Pin Functions

PIN		TYPE	DESCRIPTION
NO.	NAME		
1	V_A	Supply	Power supply input. Must be decoupled to GND.
2	V_{OUTA}	Analog Output	Channel A Analog Output Voltage.
3	V_{OUTB}	Analog Output	Channel B Analog Output Voltage.
4	V_{OUTC}	Analog Output	Channel C Analog Output Voltage.
5	V_{OUTD}	Analog Output	Channel D Analog Output Voltage.
6	GND	Ground	Ground reference for all on-chip circuitry.
7	V_{REFIN}	Analog Input	Unbuffered reference voltage shared by all channels. Must be decoupled to GND.
8	D_{IN}	Digital Input	Serial Data Input. Data is clocked into the 16-bit shift register on the falling edges of SCLK after the fall of SYNC.
9	$\overline{\text{SYNC}}$	Digital Input	Frame synchronization input for the data input. When this pin goes low, it enables the input shift register and data is transferred on the falling edges of SCLK. The DAC is updated on the 16th clock cycle unless SYNC is brought high before the 16th clock, in which case the rising edge of SYNC acts as an interrupt and the write sequence is ignored by the DAC.
10	SCLK	Digital Input	Serial Clock Input. Data is clocked into the input shift register on the falling edges of this pin.
11	PAD (SON only)	Ground	Exposed die attach pad can be connected to ground or left floating. Soldering the pad to the PCB offers optimal thermal performance and enhances package self-alignment during reflow.

7 Specifications

7.1 Absolute Maximum Ratings ⁽¹⁾⁽²⁾⁽³⁾

	MIN	MAX	UNIT
Supply voltage, V_A		6.5	V
Voltage on any input pin	-0.3	6.5	V
Input current at any pin ⁽⁴⁾		10	mA
Package input current ⁽⁴⁾		20	mA
Power consumption at $T_A = 25^\circ\text{C}$	See ⁽⁵⁾		
Junction temperature		150	$^\circ\text{C}$
Storage temperature, T_{stg}	-65	150	$^\circ\text{C}$

- (1) Stresses beyond those listed under *Absolute Maximum Ratings* may cause permanent damage to the device. These are stress ratings only, which do not imply functional operation of the device at these or any other conditions beyond those indicated under *Recommended Operating Conditions*. Exposure to absolute-maximum-rated conditions for extended periods may affect device reliability.
- (2) All voltages are measured with respect to $\text{GND} = 0\text{ V}$, unless otherwise specified.
- (3) If Military/Aerospace specified devices are required, please contact the TI Sales Office/Distributors for availability and specifications.
- (4) When the input voltage at any pin exceeds 5.5 V or is less than GND , the current at that pin should be limited to 10 mA. The 20 mA maximum package input current rating limits the number of pins that can safely exceed the power supplies with an input current of 10 mA to two.
- (5) The absolute maximum junction temperature (T_{Jmax}) for this device is 150°C . The maximum allowable power dissipation is dictated by T_{Jmax} , the junction-to-ambient thermal resistance (θ_{JA}), and the ambient temperature (T_A), and can be calculated using the formula $P_{\text{DMAX}} = (T_{\text{Jmax}} - T_A) / \theta_{\text{JA}}$. The values for maximum power dissipation is reached only when the device is operated in a severe fault condition (that is, when input or output pins are driven beyond the operating ratings, or the power supply polarity is reversed).

7.2 ESD Ratings – DAC104S085

		VALUE	UNIT
$V_{\text{(ESD)}}$ Electrostatic discharge	Human-body model (HBM), per ANSI/ESDA/JEDEC JS-001 ⁽¹⁾⁽²⁾	± 2500	V
	Machine model (MM)	± 250	

- (1) JEDEC document JEP155 states that 500-V HBM allows safe manufacturing with a standard ESD control process.
- (2) Human body model is 100-pF capacitor discharged through a 1.5-k Ω resistor. Machine model is 220 pF discharged through 0 Ω .

7.3 ESD Ratings – DAC104S085-Q1

		VALUE	UNIT
$V_{\text{(ESD)}}$ Electrostatic discharge	Human-body model (HBM), per AEC Q100-002 ⁽¹⁾	± 2500	V

- (1) AEC Q100-002 indicates that HBM stressing shall be in accordance with the ANSI/ESDA/JEDEC JS-001 specification.

7.4 Recommended Operating Conditions ⁽¹⁾

	MIN	MAX	UNIT
Operating temperature	-40	125	$^\circ\text{C}$
Supply voltage, V_A	2.7	5.5	V
Reference voltage, V_{REFIN}	1	V_A	V
Digital input voltage ⁽²⁾	0	5.5	V
Output load	0	1500	pF

- (1) All voltages are measured with respect to $\text{GND} = 0\text{ V}$, unless otherwise specified.
- (2) The inputs are protected as shown. Input voltage magnitudes up to 5.5 V, regardless of V_A , does not cause errors in the conversion result. For example, if V_A is 3 V, the digital input pins can be driven with a 5-V logic device.

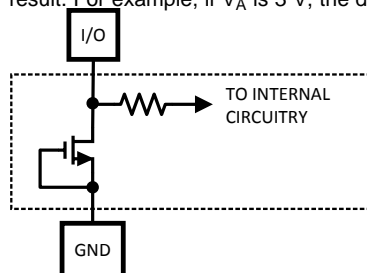

Recommended Operating Conditions⁽¹⁾ (continued)

	MIN	MAX	UNIT
SCLK frequency		40	MHz

7.5 Thermal Information

THERMAL METRIC ⁽¹⁾⁽²⁾⁽³⁾		DAC104S085-xx		UNIT
		DGS (VSSOP)	DSC (SON)	
		10 PINS	10 PINS	
R _{θJA}	Junction-to-ambient thermal resistance	159	48.9	°C/W
R _{θJC(top)}	Junction-to-case (top) thermal resistance	53.3	40.7	°C/W
R _{θJB}	Junction-to-board thermal resistance	78.9	23.7	°C/W
Ψ _{JT}	Junction-to-top characterization parameter	4.8	0.4	°C/W
Ψ _{JB}	Junction-to-board characterization parameter	77.6	23.8	°C/W
R _{θJC(bot)}	Junction-to-case (bottom) thermal resistance	N/A	4.7	°C/W

- (1) For more information about traditional and new thermal metrics, see the *Semiconductor and IC Package Thermal Metrics* application report, [SPRA953](#).
- (2) Soldering process must comply with Reflow Temperature Profile specifications. See the Absolute Maximum Ratings for Soldering application report, [SNOA549](#), for more information.
- (3) Reflow temperature profiles are different for lead-free packages.

7.6 Electrical Characteristics

The following specifications apply for V_A = 2.7 V to 5.5 V, V_{REFIN} = V_A, C_L = 200 pF to GND, f_{SCLK} = 30 MHz, input code range from 12 to 1011. All limits are at T_A = 25°C, unless otherwise specified.

PARAMETER	TEST CONDITIONS	MIN ⁽¹⁾	TYP ⁽¹⁾	MAX ⁽¹⁾	UNIT
STATIC PERFORMANCE					
Resolution	T _{MIN} ≤ T _A ≤ T _{MAX}	10			Bits
Monotonicity	T _{MIN} ≤ T _A ≤ T _{MAX}	10			Bits
INL	Integral non-linearity		±0.7		LSB
		T _{MIN} ≤ T _A ≤ T _{MAX}		±2	
DNL	Differential non-linearity	V _A = 2.7 V to 5.5 V		0.08	LSB
			T _{MIN} ≤ T _A ≤ T _{MAX}	-0.03	
ZE	Zero code error	I _{OUT} = 0 mA		5	mV
			T _{MIN} ≤ T _A ≤ T _{MAX}		
FSE	Full-scale error	I _{OUT} = 0 mA		-0.1	%FSR
			T _{MIN} ≤ T _A ≤ T _{MAX}		
GE	Gain error	All ones Loaded to DAC register		-0.2	%FSR
			T _{MIN} ≤ T _A ≤ T _{MAX}		
ZCED	Zero code error drift		-20		μV/°C
TC GE	Gain error tempco	V _A = 3 V		-0.7	ppm/°C
		V _A = 5 V		-1	
OUTPUT CHARACTERISTICS					
Output voltage range	See ⁽²⁾ , T _{MIN} ≤ T _A ≤ T _{MAX}	0		0	V
I _{oz}	High-impedance output leakage current ⁽²⁾			±1	μA
ZCO	Zero code output	V _A = 3 V, I _{OUT} = 200 μA		1.3	mV
		V _A = 3 V, I _{OUT} = 1 mA		6	
		V _A = 5 V, I _{OUT} = 200 μA		7	
		V _A = 5 V, I _{OUT} = 1 mA		10	

- (1) Typical figures are at T_J = 25°C, and represent most likely parametric norms. Test limits are specified to TI's AOQL (Average Outgoing Quality Level).
- (2) This parameter is ensured by design and/or characterization and is not tested in production.

Electrical Characteristics (continued)

The following specifications apply for $V_A = 2.7\text{ V}$ to 5.5 V , $V_{REFIN} = V_A$, $C_L = 200\text{ pF}$ to GND, $f_{SCLK} = 30\text{ MHz}$, input code range from 12 to 1011. All limits are at $T_A = 25^\circ\text{C}$, unless otherwise specified.

PARAMETER		TEST CONDITIONS		MIN ⁽¹⁾	TYP ⁽¹⁾	MAX ⁽¹⁾	UNIT	
FSO	Full-scale output	$V_A = 3\text{ V}$, $I_{OUT} = 200\text{ }\mu\text{A}$			2.984		V	
		$V_A = 3\text{ V}$, $I_{OUT} = 1\text{ mA}$			2.934			
		$V_A = 5\text{ V}$, $I_{OUT} = 200\text{ }\mu\text{A}$			4.989			
		$V_A = 5\text{ V}$, $I_{OUT} = 1\text{ mA}$			4.958			
I_{OS}	Output short-circuit current (source)	$V_A = 3\text{ V}$, $V_{OUT} = 0\text{ V}$, Input Code = 3FFh			-56		mA	
		$V_A = 5\text{ V}$, $V_{OUT} = 0\text{ V}$, Input Code = 3FFh			-69			
I_{OS}	Output short-circuit current (sink)	$V_A = 3\text{ V}$, $V_{OUT} = 3\text{ V}$, Input Code = 000h			52		mA	
		$V_A = 5\text{ V}$, $V_{OUT} = 5\text{ V}$, Input Code = 000h			75			
I_O	Continuous output current ⁽²⁾	Available on each DAC output, $T_{MIN} \leq T_A \leq T_{MAX}$				11	mA	
C_L	Maximum load capacitance	$R_L = \infty$			1500		pF	
		$R_L = 2\text{ k}\Omega$			1500			
Z_{OUT}	DC output impedance				7.5		Ω	
REFERENCE INPUT CHARACTERISTICS								
VREFIN	Input range minimum				0.2		V	
		$T_{MIN} \leq T_A \leq T_{MAX}$		1				
	Input range maximum	$T_{MIN} \leq T_A \leq T_{MAX}$				V_A	V	
	Input impedance				30		k Ω	
LOGIC INPUT CHARACTERISTICS								
I_{IN}	Input current ⁽²⁾	$T_{MIN} \leq T_A \leq T_{MAX}$				± 1	μA	
V_{IL}	Input low voltage ⁽²⁾	$V_A = 3\text{ V}$				0.9	0.6	V
			$T_{MIN} \leq T_A \leq T_{MAX}$					
		$V_A = 5\text{ V}$				1.5	0.8	V
			$T_{MIN} \leq T_A \leq T_{MAX}$					
V_{IH}	Input high voltage ⁽²⁾	$V_A = 3\text{ V}$				1.4	2.1	V
			$T_{MIN} \leq T_A \leq T_{MAX}$					
		$V_A = 5\text{ V}$				2.1	2.4	V
			$T_{MIN} \leq T_A \leq T_{MAX}$					
C_{IN}	Input capacitance ⁽²⁾	$T_{MIN} \leq T_A \leq T_{MAX}$				3	pF	
POWER REQUIREMENTS								
V_A ⁽³⁾	Supply voltage minimum	$T_{MIN} \leq T_A \leq T_{MAX}$			2.7		V	
	Supply voltage maximum	$T_{MIN} \leq T_A \leq T_{MAX}$				5.5	V	
I_N	Normal supply current (output unloaded)	$f_{SCLK} = 30\text{ MHz}$	$V_A = 2.7\text{ V}$ to 3.6 V			350	μA	
				$T_{MIN} \leq T_A \leq T_{MAX}$		485		
			$f_{SCLK} = 0\text{ MHz}$	$V_A = 4.5\text{ V}$ to 5.5 V			500	μA
		$T_{MIN} \leq T_A \leq T_{MAX}$			650			
		$V_A = 2.7\text{ V}$ to 3.6 V				330	μA	
			$V_A = 4.5\text{ V}$ to 5.5 V		460	μA		
I_{PD}	Power-down supply current (output unloaded, SYNC = DIN = 0V after PD mode loaded)	All PD Modes, ⁽²⁾	$V_A = 2.7\text{ V}$ to 3.6 V			0.1	μA	
				$T_{MIN} \leq T_A \leq T_{MAX}$		1		
		$V_A = 4.5\text{ V}$ to 5.5 V			0.15	μA		
			$T_{MIN} \leq T_A \leq T_{MAX}$		1			

(3) To ensure accuracy, it is required that V_A and V_{REFIN} be well bypassed.

Electrical Characteristics (continued)

The following specifications apply for $V_A = 2.7\text{ V}$ to 5.5 V , $V_{REFIN} = V_A$, $C_L = 200\text{ pF}$ to GND, $f_{SCLK} = 30\text{ MHz}$, input code range from 12 to 1011. All limits are at $T_A = 25^\circ\text{C}$, unless otherwise specified.

PARAMETER		TEST CONDITIONS		MIN ⁽¹⁾	TYP ⁽¹⁾	MAX ⁽¹⁾	UNIT
P_N	Normal supply power (output unloaded)	$f_{SCLK} = 30\text{ MHz}$	$V_A = 2.7\text{ V}$ to 3.6 V	$T_{MIN} \leq T_A \leq T_{MAX}$	1.1		mW
			$V_A = 4.5\text{ V}$ to 5.5 V		1.7		
		$f_{SCLK} = 0\text{ MHz}$	$V_A = 2.7\text{ V}$ to 3.6 V	$T_{MIN} \leq T_A \leq T_{MAX}$	2.5		mW
			$V_A = 4.5\text{ V}$ to 5.5 V		3.6		
P_{PD}	Power-down supply power (output unloaded, SYNC = DIN = 0V after PD mode loaded)	All PD Modes, ⁽²⁾	$V_A = 2.7\text{ V}$ to 3.6 V	$T_{MIN} \leq T_A \leq T_{MAX}$	0.3		μW
			$V_A = 4.5\text{ V}$ to 5.5 V		3.6		
		$f_{SCLK} = 0\text{ MHz}$	$V_A = 2.7\text{ V}$ to 3.6 V	$T_{MIN} \leq T_A \leq T_{MAX}$	1		mW
			$V_A = 4.5\text{ V}$ to 5.5 V		2.3		
$f_{SCLK} = 30\text{ MHz}$	$V_A = 2.7\text{ V}$ to 3.6 V	$T_{MIN} \leq T_A \leq T_{MAX}$	0.8		μW		
	$V_A = 4.5\text{ V}$ to 5.5 V		5.5				

7.7 Timing Requirements

Values shown in this table are design targets and are subject to change before product release.

The following specifications apply for $V_A = 2.7\text{ V}$ to 5.5 V , $V_{REFIN} = V_A$, $C_L = 200\text{ pF}$ to GND, $f_{SCLK} = 30\text{ MHz}$, input code range from 12 to 1011. All limits are at $T_A = 25^\circ\text{C}$, unless otherwise specified.

				MIN ⁽¹⁾	TYP ⁽¹⁾	MAX ⁽¹⁾	UNIT
f_{SCLK}	SCLK frequency			40		30	MHz
		$T_{MIN} \leq T_A \leq T_{MAX}$					
t_s	Output voltage settling time ⁽²⁾	100h to 300h code change $R_L = 2\text{ k}\Omega$, $C_L = 200\text{ pF}$	$T_{MIN} \leq T_A \leq T_{MAX}$	4.5		6	μs
SR	Output slew rate			1		$\text{V}/\mu\text{s}$	
	Glitch impulse	Code change from 200h to 1FFh		12		nV-sec	
	Digital feedthrough			0.5		nV-sec	
	Digital crosstalk			1		nV-sec	
	DAC-to-DAC crosstalk			3		nV-sec	
	Multiplying bandwidth	$V_{REFIN} = 2.5\text{ V} \pm 0.1\text{ Vpp}$		160		kHz	
	Total harmonic distortion	$V_{REFIN} = 2.5\text{ V} \pm 0.1\text{ Vpp}$ input frequency = 10 kHz		70		dB	
t_{WU}	Wake-up time	$V_A = 3\text{ V}$		6		μsec	
		$V_A = 5\text{ V}$		39		μsec	
$1/f_{SCLK}$	SCLK cycle time			25		ns	
		$T_{MIN} \leq T_A \leq T_{MAX}$		33			
t_{CH}	SCLK high time			7		ns	
		$T_{MIN} \leq T_A \leq T_{MAX}$		10			
t_{CL}	SCLK low Time			7		ns	
		$T_{MIN} \leq T_A \leq T_{MAX}$		10			
t_{SS}	$\overline{\text{SYNC}}$ set-up time prior to SCLK falling edge			4		ns	
		$T_{MIN} \leq T_A \leq T_{MAX}$		10			
t_{DS}	Data set-up time prior to SCLK falling edge			1.5		ns	
		$T_{MIN} \leq T_A \leq T_{MAX}$		3.5			
t_{DH}	Data hold time after SCLK falling edge			1.5		ns	
		$T_{MIN} \leq T_A \leq T_{MAX}$		3.5			
t_{CFSR}	SCLK fall prior to rise of $\overline{\text{SYNC}}$			0		ns	
		$T_{MIN} \leq T_A \leq T_{MAX}$		3			

(1) Typical figures are at $T_J = 25^\circ\text{C}$, and represent most likely parametric norms. Test limits are specified to TI's AOQL (Average Outgoing Quality Level).

(2) This parameter is ensured by design and/or characterization and is not tested in production.

Timing Requirements (continued)

Values shown in this table are design targets and are subject to change before product release.

The following specifications apply for $V_A = 2.7\text{ V}$ to 5.5 V , $V_{REFIN} = V_A$, $C_L = 200\text{ pF}$ to GND, $f_{SCLK} = 30\text{ MHz}$, input code range from 12 to 1011. All limits are at $T_A = 25^\circ\text{C}$, unless otherwise specified.

		MIN ⁽¹⁾	TYP ⁽¹⁾	MAX ⁽¹⁾	UNIT
t_{SYNC}	\overline{SYNC} high time		6		ns
	$T_{MIN} \leq T_A \leq T_{MAX}$	10			

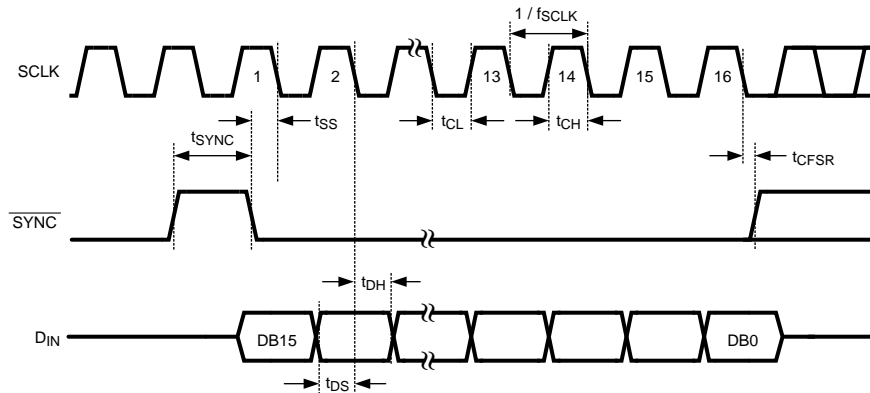
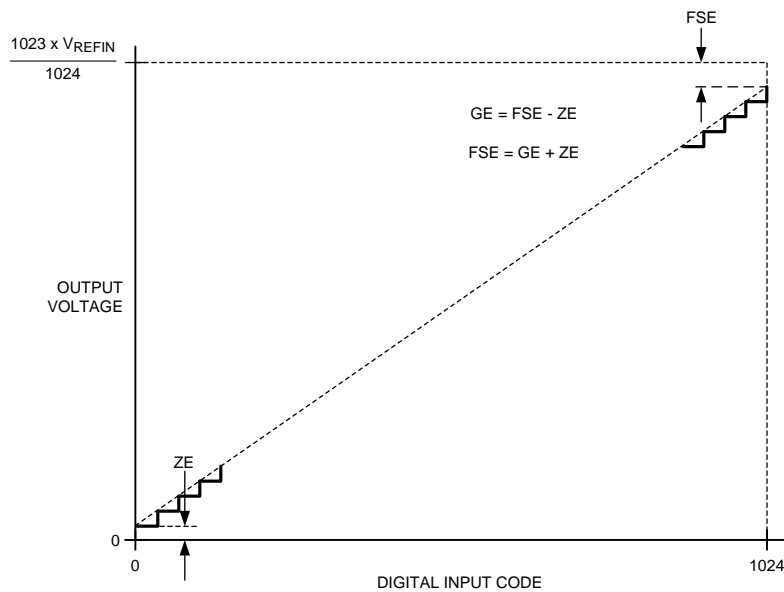

Figure 1. Serial Timing Diagram



Input / Output Transfer Characteristic

7.8 Typical Characteristics

$V_{REF} = V_A$, $f_{SCLK} = 30$ MHz, $T_A = 25^\circ\text{C}$, Input Code Range from 12 to 1011, unless otherwise stated

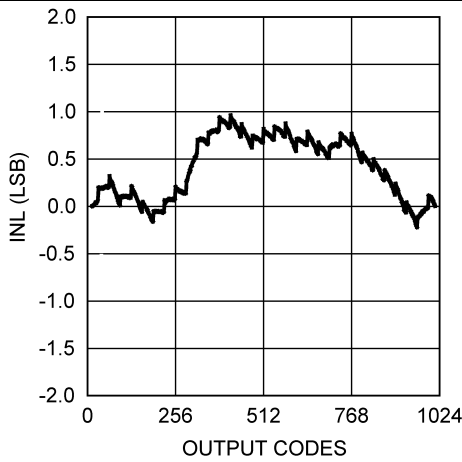

Figure 2. INL at $V_A = 3$ V

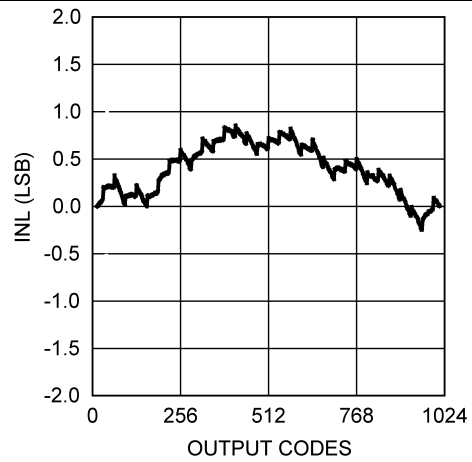

Figure 3. INL at $V_A = 5$ V

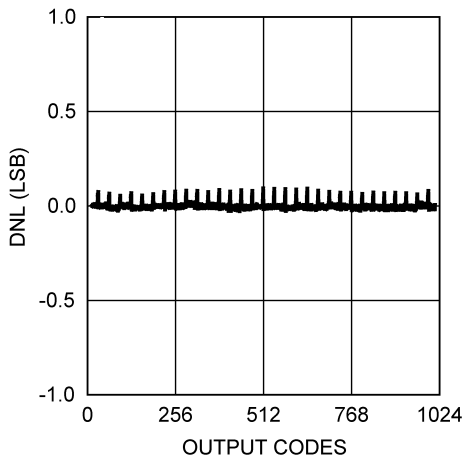

Figure 4. DNL at $V_A = 3$ V

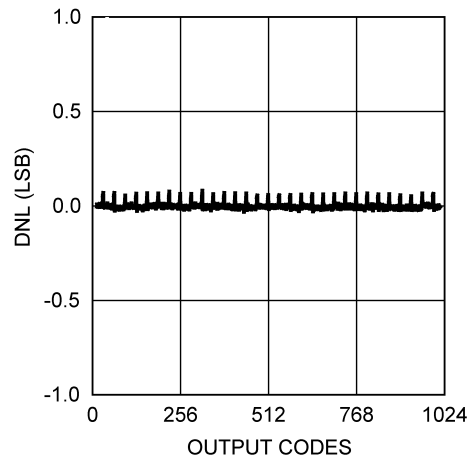

Figure 5. DNL at $V_A = 5$ V

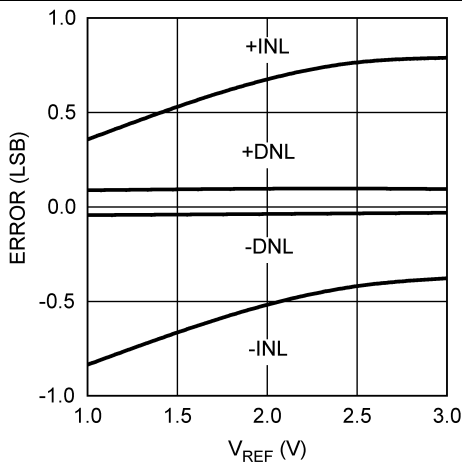

Figure 6. INL/DNL vs V_{REFIN} at $V_A = 3$ V

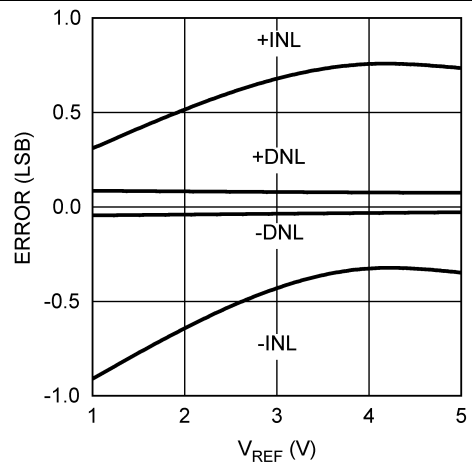
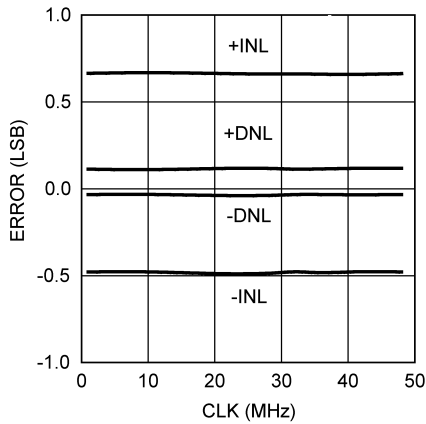
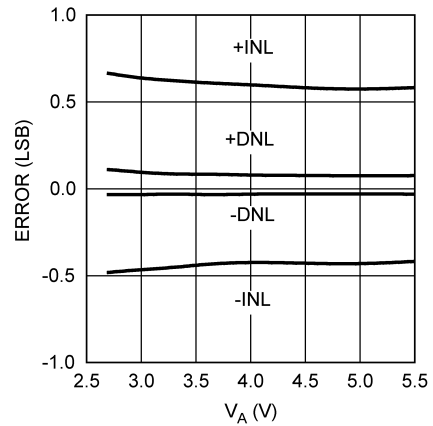
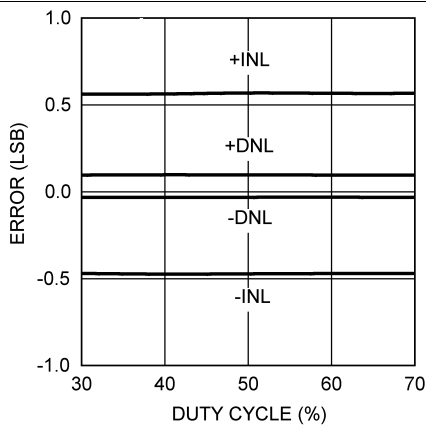
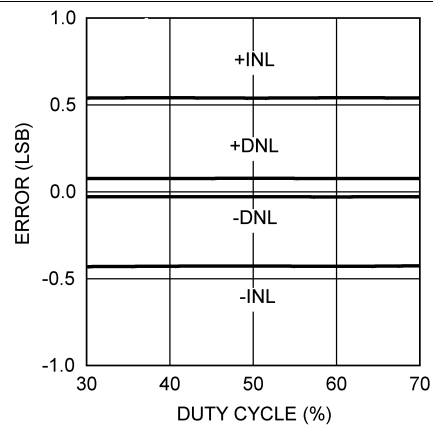
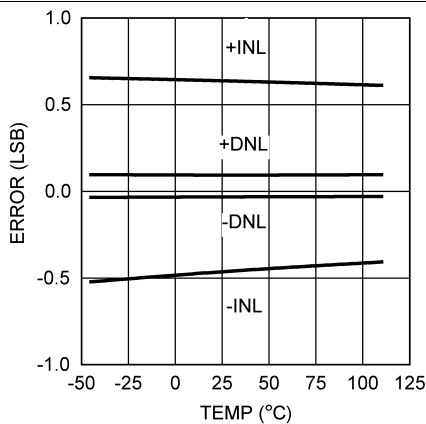
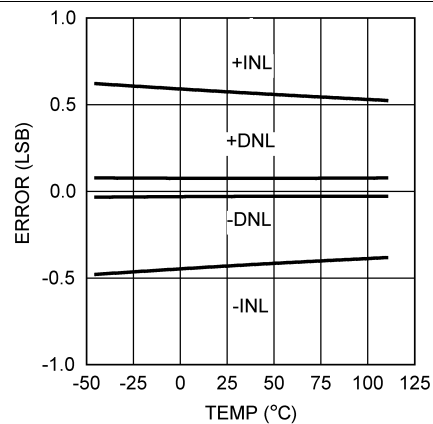

Figure 7. INL/DNL vs V_{REFIN} at $V_A = 5$ V

Typical Characteristics (continued)
 $V_{REF} = V_A$, $f_{SCLK} = 30$ MHz, $T_A = 25^\circ\text{C}$, Input Code Range from 12 to 1011, unless otherwise stated

Figure 8. INL/DNL vs f_{SCLK} at $V_A = 2.7$ V

Figure 9. INL/DNL vs V_A

Figure 10. INL/DNL vs Clock Duty Cycle at $V_A = 3$ V

Figure 11. INL/DNL vs Clock Duty Cycle at $V_A = 5$ V

Figure 12. INL/DNL vs Temperature at $V_A = 3$ V

Figure 13. INL/DNL vs Temperature at $V_A = 5$ V

Typical Characteristics (continued)

$V_{REF} = V_A$, $f_{SCLK} = 30$ MHz, $T_A = 25^\circ\text{C}$, Input Code Range from 12 to 1011, unless otherwise stated

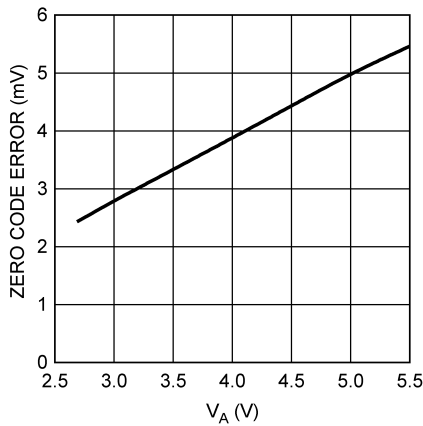

Figure 14. Zero Code Error vs V_A

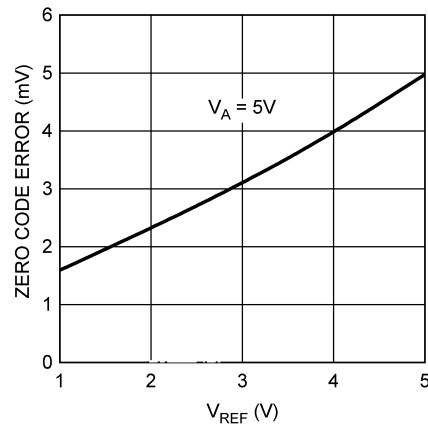

Figure 15. Zero Code Error vs. V_{REFIN}

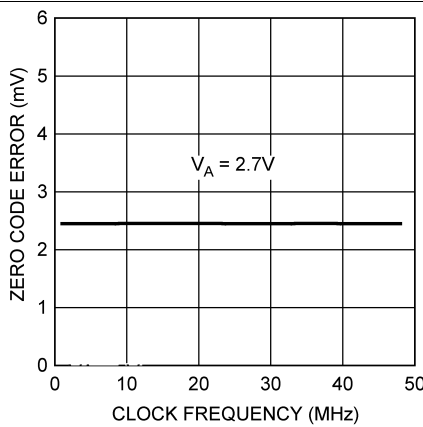

Figure 16. Zero Code Error vs f_{SCLK}

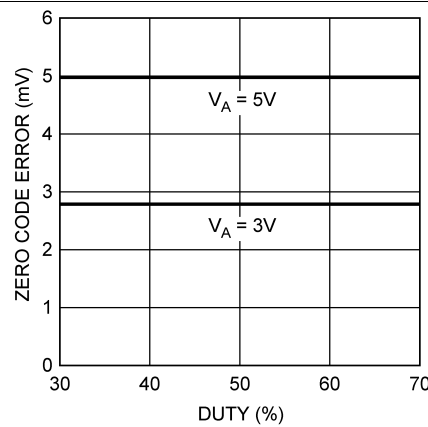

Figure 17. Zero Code Error vs Clock Duty Cycle

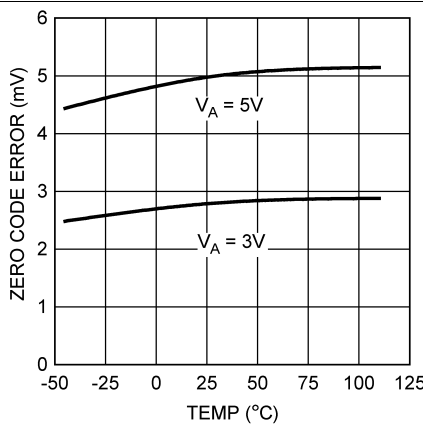

Figure 18. Zero Code Error vs Temperature

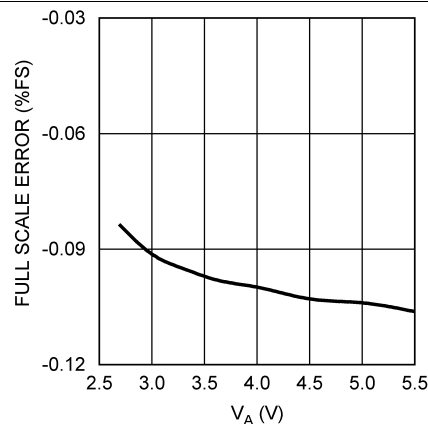
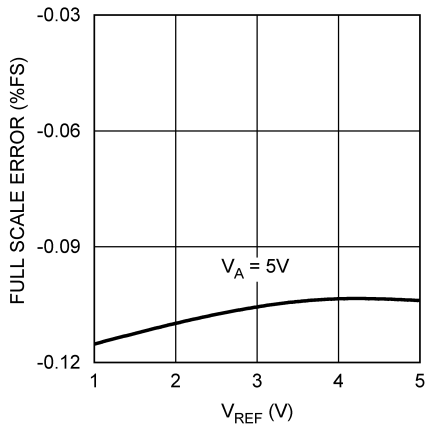
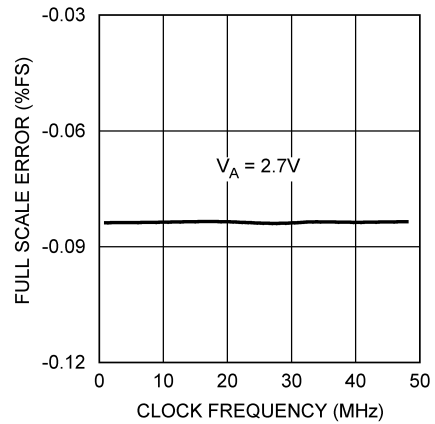
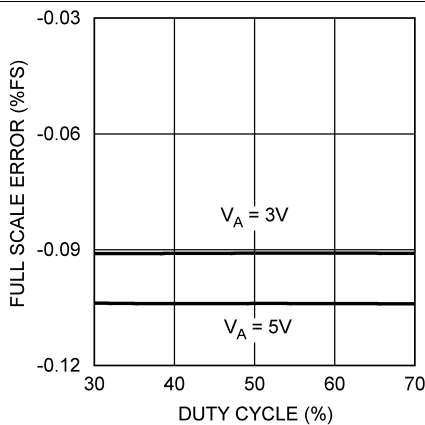
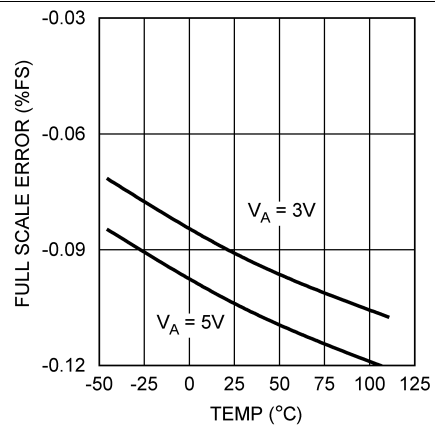
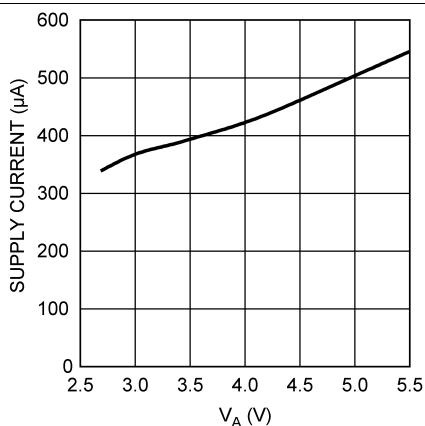
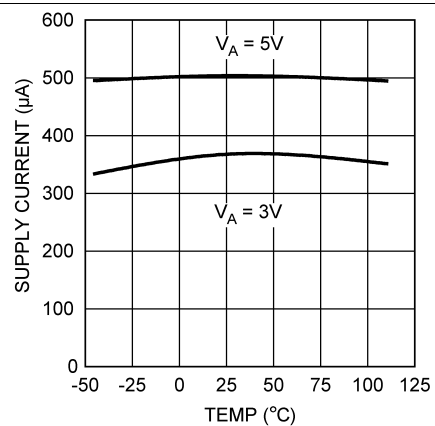

Figure 19. Full-Scale Error vs V_A

Typical Characteristics (continued)
 $V_{REF} = V_A$, $f_{SCLK} = 30$ MHz, $T_A = 25^\circ\text{C}$, Input Code Range from 12 to 1011, unless otherwise stated

Figure 20. Full-Scale Error vs V_{REFIN}

Figure 21. Full-Scale Error vs f_{SCLK}

Figure 22. Full-Scale Error vs Clock Duty Cycle

Figure 23. Full-Scale Error vs Temperature

Figure 24. Supply Current vs V_A

Figure 25. Supply Current vs Temperature

8 Detailed Description

8.1 Overview

The DAC104S085 is fabricated on a CMOS process with an architecture that consists of switches and resistor strings that are followed by an output buffer. The reference voltage is externally applied at V_{REFIN} and is shared by all four DACs.

For simplicity, [Figure 26](#) shows a single resistor string. This string consists of 1024 equal valued resistors with a switch at each junction of two resistors, plus a switch to ground. The code loaded into the DAC register determines which switch is closed, connecting the proper node to the amplifier. The input coding is straight binary with an ideal output voltage found in [Equation 1](#):

$$V_{OUTA,B,C,D} = V_{REFIN} \times (D / 1024)$$

where

- D is the decimal equivalent of the binary code that is loaded into the DAC register. D can take on any value between 0 and 1023. This configuration ensures that the DAC is monotonic. (1)

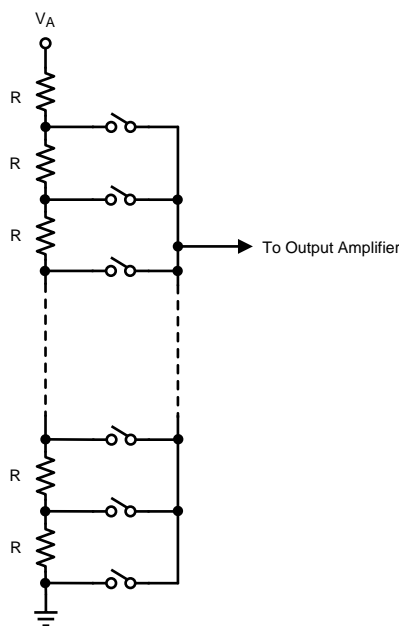
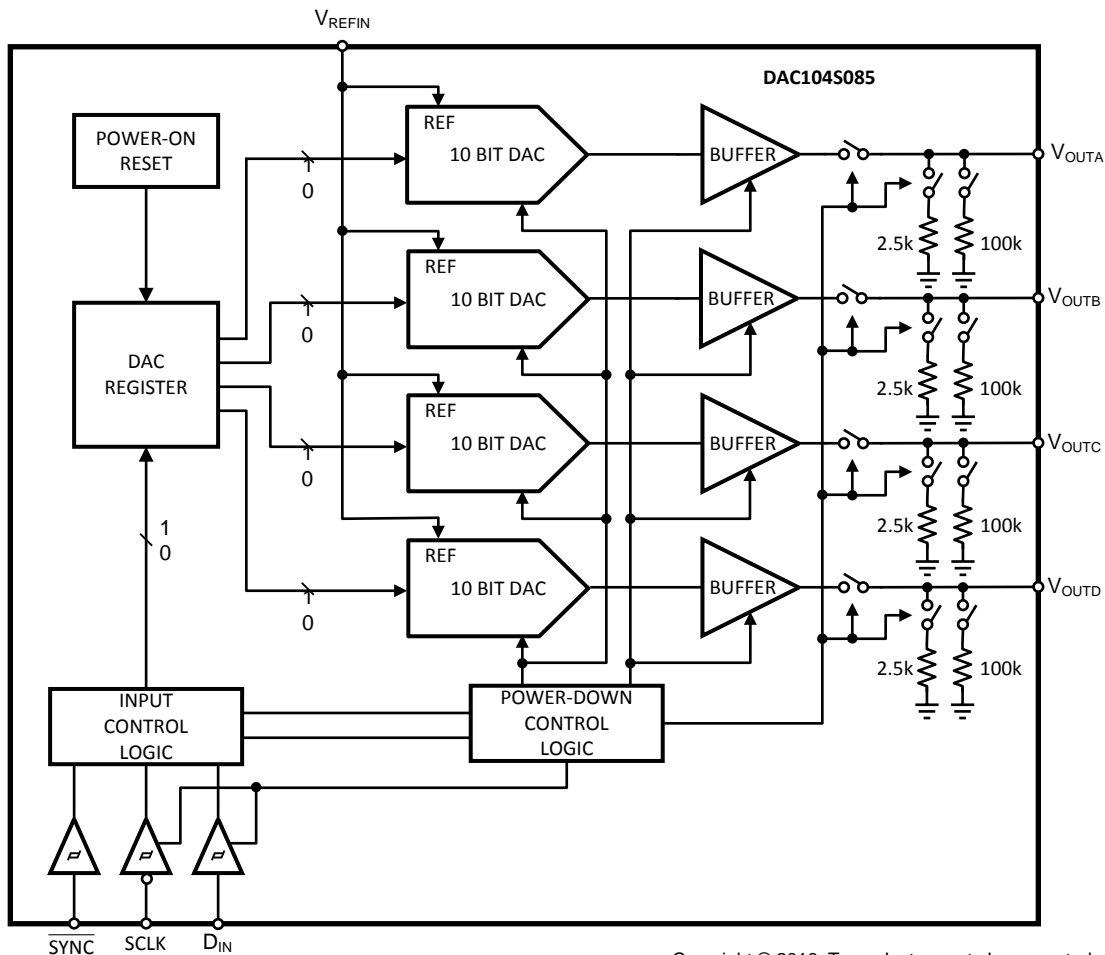

Figure 26. DAC Resistor String

8.2 Functional Block Diagram



Copyright © 2016, Texas Instruments Incorporated

8.3 Feature Description

8.3.1 Output Amplifiers

The output amplifiers are rail-to-rail, providing an output voltage range of 0 V to V_A when the reference is V_A . All amplifiers, even rail-to-rail types, exhibit a loss of linearity as the output approaches the supply rails (0 V and V_A , in this case). For this reason, linearity is specified over less than the full output range of the DAC. However, if the reference is less than V_A , there is only a loss in linearity in the lowest codes. The output capabilities of the amplifier are described in [Electrical Characteristics](#).

The output amplifiers are capable of driving a load of 2 k Ω in parallel with 1500 pF to ground or to V_A . The zero-code and full-scale outputs for given load currents are available in [Electrical Characteristics](#).

8.3.2 Reference Voltage

The DAC104S085 uses a single external reference that is shared by all four channels. The reference pin, V_{REFIN} , is not buffered and has an input impedance of 30 k Ω . TI recommends driving the V_{REFIN} by a voltage source with low output impedance. The reference voltage range is 1 V to V_A , providing the widest possible output dynamic range.

8.3.3 Power-On Reset

The power-on reset circuit controls the output voltages of the four DACs during power up. Upon application of power, the DAC registers are filled with zeros and the output voltages are 0 V. The outputs remain at 0 V until a valid write sequence is made to the DAC.

8.4 Device Functional Modes

8.4.1 Power-Down Modes

The DAC104S085 has four power-down modes, two of which are identical. In power-down mode, the supply current drops to 20 μA at 3 V and 30 μA at 5 V. The DAC104S085 is set in power-down mode by setting OP1 and OP0 to 11. Because this mode powers down all four DACs, the address bits, A1 and A0, are used to select different output terminations for the DAC outputs. Setting A1 and A0 to 00 or 11 causes the outputs to be tri-stated (a high impedance state). While setting A1 and A0 to 01 or 10 causes the outputs to be terminated by 2.5 k Ω or 100 k Ω to ground respectively (see [Table 1](#)).

Table 1. Power-Down Modes

A1	A0	OP1	OP0	OPERATING MODE
0	0	1	1	High-Z outputs
0	1	1	1	2.5 k Ω to GND
1	0	1	1	100 k Ω to GND
1	1	1	1	High-Z outputs

The bias generator, output amplifiers, resistor strings, and other linear circuitry are all shut down in any of the power-down modes. However, the contents of the DAC registers are unaffected when in power down. Each DAC register maintains its value prior to the DAC104S085 being powered down unless it is changed during the write sequence that instructed it to recover from power down. Minimum power consumption is achieved in the power-down mode with SYNC and D_{IN} idled low and SCLK disabled. The time to exit power down (Wake-Up Time) is typically t_{WU} μs as stated in [Timing Requirements](#).

8.4.2 Bipolar Operation

The DAC104S085 is designed for single-supply operation and thus has a unipolar output. However, a bipolar output may be obtained with the circuit in [Figure 27](#). This circuit provides an output voltage range of ± 5 V. A rail-to-rail amplifier should be used if the amplifier supplies are limited to ± 5 V.

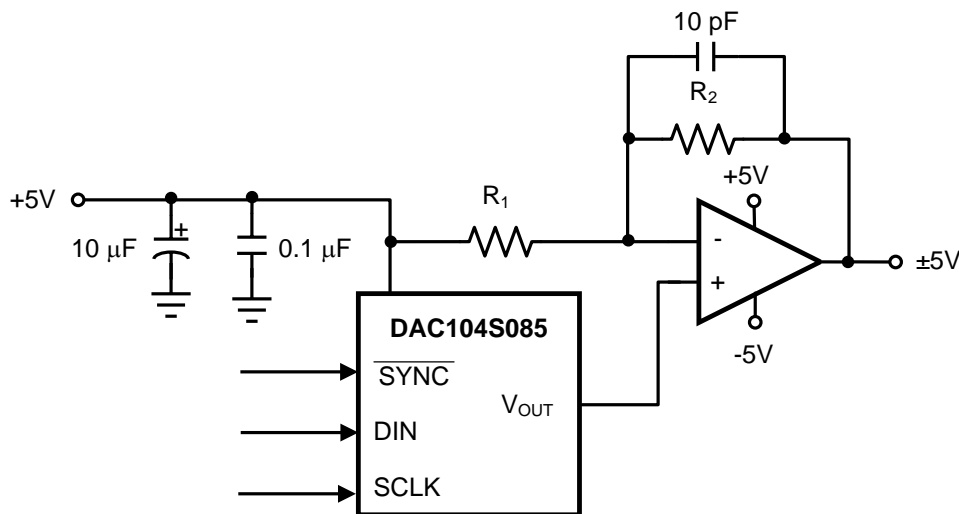

Copyright © 2016, Texas Instruments Incorporated

Figure 27. Bipolar Operation

The output voltage of this circuit for any code is found in [Equation 2](#) and [Equation 3](#).

$$V_O = (V_A \times (D / 1024) \times ((R_1 + R_2) / R_1) - V_A \times R_2 / R_1)$$

where

- D is the input code in decimal form
- With $V_A = 5$ V and $R_1 = R_2$

(2)

$$V_O = (10 \times D / 1024) - 5 \text{ V} \quad (3)$$

A list of rail-to-rail amplifiers suitable for this application are indicated in [Table 2](#).

Table 2. Some Rail-to-Rail Amplifiers

AMP	PKGS	TYP V_{OS}	TYP I_{SUPPLY}
LMC7111	DIP-8 SOT23-5	0.9 mV	25 μ A
LM7301	SO-8 SOT23-5	0.03 mV	620 μ A
LM8261	SOT23-5	0.7 mV	1 mA

8.5 Programming

8.5.1 Serial Interface

The three-wire interface is compatible with SPI, QSPI, and MICROWIRE, as well as most DSPs and operates at clock rates up to 40 MHz. See the [Figure 1](#) for information on a write sequence.

A write sequence begins by bringing the \overline{SYNC} line low. Once \overline{SYNC} is low, the data on the D_{IN} line is clocked into the 16-bit serial input register on the falling edges of SCLK. To avoid mislocking data into the shift register, it is critical that \overline{SYNC} not be brought low simultaneously with a falling edge of SCLK (see [Figure 1](#)). On the 16th falling clock edge, the last data bit is clocked in and the programmed function (a change in the DAC channel address, mode of operation and/or register contents) is executed. At this point the \overline{SYNC} line may be kept low or brought high. Any data and clock pulses after the 16th falling clock edge is ignored. In either case, \overline{SYNC} must be brought high for the minimum specified time before the next write sequence is initiated with a falling edge of \overline{SYNC} .

Because the \overline{SYNC} and D_{IN} buffers draw more current when they are high, they must be idled low between write sequences to minimize power consumption.

8.5.2 Input Shift Register

The input shift register, [Figure 28](#), has sixteen bits. The first two bits are address bits. They determine whether the register data is for DAC A, DAC B, DAC C, or DAC D. The address bits are followed by two bits that determine the mode of operation (writing to a DAC register without updating the outputs of all four DACs, writing to a DAC register and updating the outputs of all four DACs, writing to the register of all four DACs and updating their outputs, or powering down all four outputs). The final twelve bits of the shift register are the data bits. The data format is straight binary (MSB first, LSB last), with all 0s corresponding to an output of 0 V and all 1s corresponding to a full-scale output of $V_{REFIN} - 1$ LSB. The contents of the serial input register are transferred to the DAC register on the sixteenth falling edge of SCLK. See [Figure 1](#).

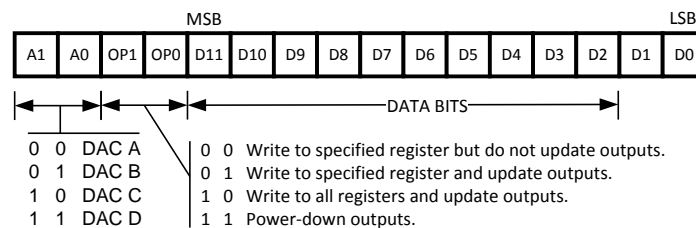

Figure 28. Input Register Contents

Normally, the \overline{SYNC} line is kept low for at least 16 falling edges of SCLK and the DAC is updated on the 16th SCLK falling edge. However, if \overline{SYNC} is brought high before the 16th falling edge, the data transfer to the shift register is aborted and the write sequence is invalid. Under this condition, the DAC register is not updated and there is no change in the mode of operation or in the DAC output voltages.

8.5.3 DSP and Microprocessor Interfacing

Interfacing the DAC104S085 to microprocessors and DSPs is quite simple. The following guidelines are offered to hasten the design process.

Programming (continued)

8.5.3.1 ADSP-2101 and ADSP2103 Interfacing

Figure 29 shows a serial interface between the DAC104S085 and the ADSP-2101 or ADSP2103. The DSP must be set to operate in the SPORT Transmit Alternate Framing Mode. It is programmed through the SPORT control register and must be configured for Internal Clock Operation, Active Low Framing and 16-bit Word Length. Transmission is started by writing a word to the Tx register after the SPORT mode has been enabled.

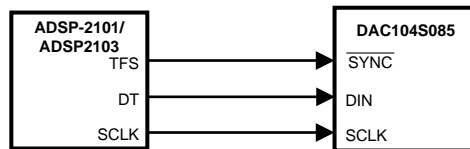

Figure 29. ADSP-2101 and ADSP2103 Interface

8.5.3.2 80C51 and 80L51 Interface

Figure 30 shows a serial interface between the DAC104S085 and the 80C51/80L51 microcontroller. The $\overline{\text{SYNC}}$ signal comes from a bit-programmable pin on the microcontroller. The example shown in Figure 30 uses port line P3.3. This line is taken low when data is transmitted to the DAC104S085. Because the 80C51 and 80L51 transmits 8-bit bytes, only eight falling clock edges occur in the transmit cycle. To load data into the DAC, the P3.3 line must be left low after the first eight bits are transmitted. A second write cycle is initiated to transmit the second byte of data, after which port line P3.3 is brought high. The 80C51 and 80L51 transmit routine must recognize that the 80C51 and 80L51 transmits data with the LSB first while the DAC104S085 requires data with the MSB first.

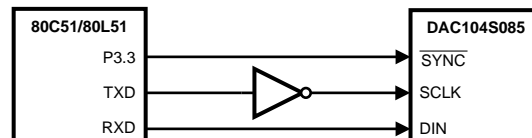

Figure 30. 80C51 and 80L51 Interface

8.5.3.3 68HC11 Interface

Figure 31 shows a serial interface between the DAC104S085 and the 68HC11 microcontroller. The $\overline{\text{SYNC}}$ line of the DAC104S085 is driven from a port line (PC7 in Figure 31), similar to the 80C51/80L51.

The 68HC11 must be configured with its CPOL bit as a zero and its CPHA bit as a one. This configuration causes data on the MOSI output to be valid on the falling edge of SCLK. PC7 is taken low to transmit data to the DAC. The 68HC11 transmits data in 8-bit bytes with eight falling clock edges. Data is transmitted with the MSB first. PC7 must remain low after the first eight bits are transferred. A second write cycle is initiated to transmit the second byte of data to the DAC, after which PC7 must be raised to end the write sequence.

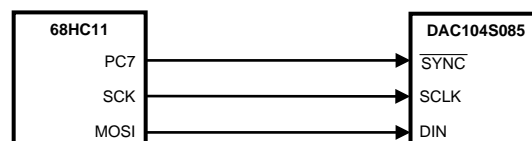
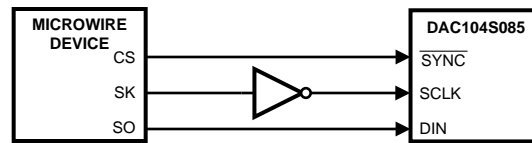

Figure 31. 68HC11 Interface

8.5.3.4 Microwire Interface

Figure 32 shows an interface between a Microwire compatible device and the DAC104S085. Data is clocked out on the rising edges of the SK signal. As a result, the SK of the Microwire device needs to be inverted before driving the SCLK of the DAC104S085.

Programming (continued)

Figure 32. Microwire Interface

9 Application and Implementation

NOTE

Information in the following applications sections is not part of the TI component specification, and TI does not warrant its accuracy or completeness. TI's customers are responsible for determining suitability of components for their purposes. Customers should validate and test their design implementation to confirm system functionality.

9.1 Application Information

While the simplicity of the DAC104S085 implies ease of use, it is important to recognize that the path from the reference input (V_{REFIN}) to the VOUTs has essentially zero Power Supply Rejection Ratio (PSRR). Therefore, it is necessary to provide a noise-free supply voltage to V_{REFIN} . To use the full dynamic range of the DAC104S085, the supply pin (V_A) and V_{REFIN} can be connected together and share the same supply voltage. Because the DAC104S085 consumes very little power, a reference source may be used as the reference input and/or the supply voltage. The advantages of using a reference source over a voltage regulator are accuracy and stability. Some low noise regulators can also be used. Listed below are a few reference and power-supply options for the DAC104S085.

9.1.1 LM4130

The LM4130, with its 0.05% accuracy over temperature, is a good choice as a reference source for the DAC104S085. The 4.096-V version is useful if a 0 to 4.095-V output range is desirable or acceptable. Bypassing the LM4130 VIN pin with a 0.1- μ F capacitor and the VOUT pin with a 2.2- μ F capacitor improves stability and reduces output noise. The LM4130 comes in a space-saving, 5-pin SOT-23.

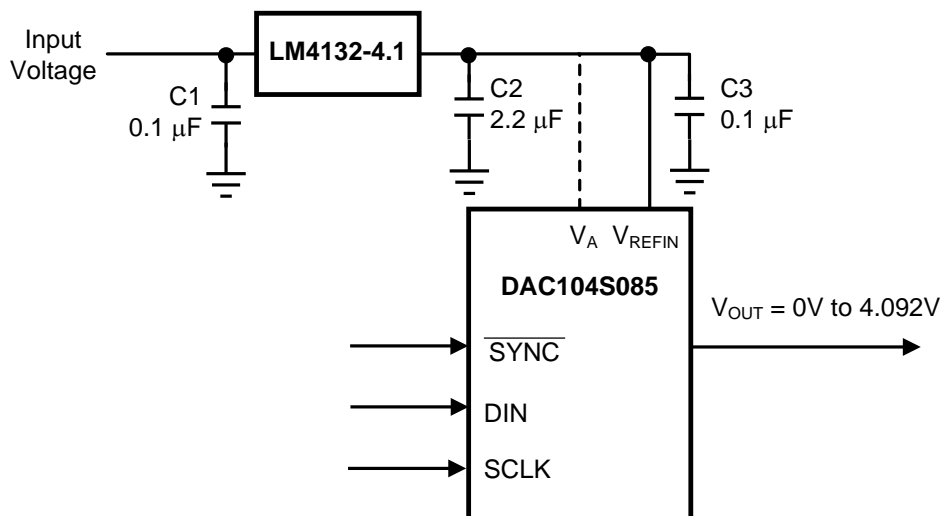

Copyright © 2016, Texas Instruments Incorporated

Figure 33. LM4130 as a Power Supply

9.1.2 LP3985

The LP3985 is a low-noise, ultra-low dropout voltage regulator with a 3% accuracy over temperature. It is a good choice for applications that do not require a precision reference for the DAC104S085. It comes in 3-V, 3.3-V, and 5-V versions, among others, and sports a low 30- μ V noise specification at low frequencies. Because low-frequency noise is relatively difficult to filter, this specification could be important for some applications. The LP3985 device comes in a space-saving, 5-pin SOT-23 and 5-bump DSBGA packages.

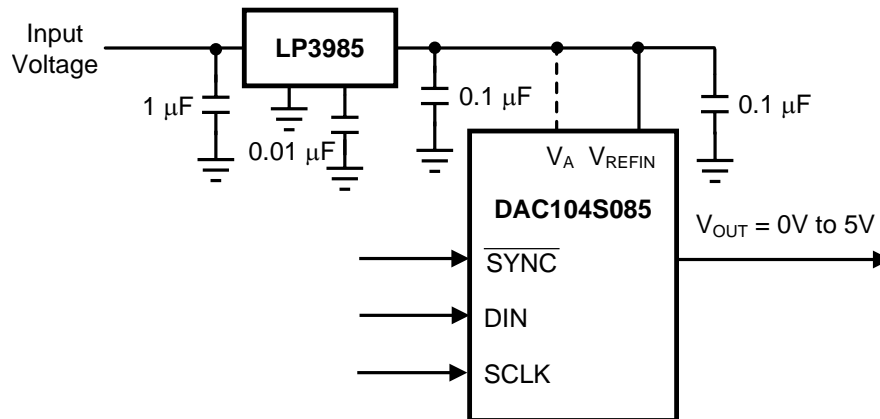
Application Information (continued)

Copyright © 2016, Texas Instruments Incorporated

Figure 34. Using the LP3985 Regulator

An input capacitance of 1- μ F without any ESR requirement is required at the LP3985 input, while a 1- μ F ceramic capacitor with an ESR requirement of 5 m Ω to 500 m Ω is required at the output. Careful interpretation and understanding of the capacitor specification is required to ensure correct device operation.

9.1.3 LP2980

The LP2980 is an ultra-low dropout regulator with a 0.5% or 1% accuracy over temperature, depending upon grade. It is available in 3-V, 3.3-V, and 5-V versions, among others.

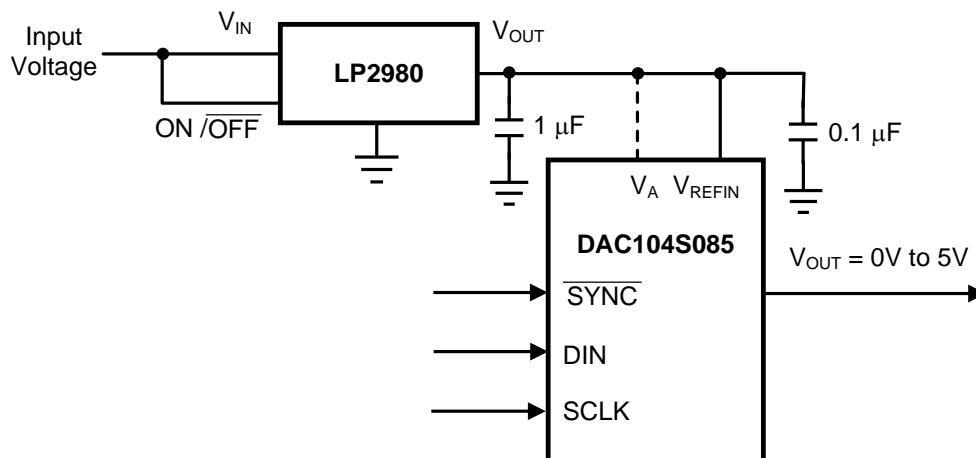

Copyright © 2016, Texas Instruments Incorporated

Figure 35. Using the LP2980 Regulator

Like any low dropout regulator, the LP2980 requires an output capacitor for loop stability. This output capacitor must be at least 1 μ F over temperature, but values of 2.2 μ F or more provides even better performance. The ESR of this capacitor should be within the range specified in the LP2980 data sheet ([SNOS733](#)). Surface-mount solid tantalum capacitors offer a good combination of small size and ESR. Ceramic capacitors are attractive due to their small size, but, generally have ESR values that are too low for use with the LP2980. Aluminum electrolytic capacitors are typically not a good choice due to their large size and have ESR values that may be too high at low temperatures.

9.2 Typical Application

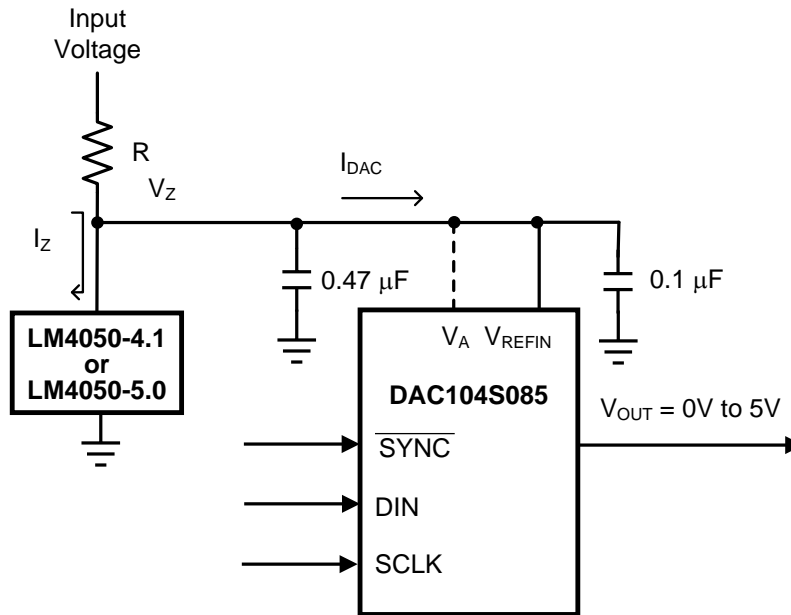

Copyright © 2016, Texas Instruments Incorporated

Figure 36. The LM4050 as a Power Supply

9.2.1 Design Requirements

While the simplicity of the DAC104S085 implies ease of use, it is important to recognize that the path from the reference input (V_{REFIN}) to the VOUTs has essentially zero Power Supply Rejection Ratio (PSRR). Therefore, it is necessary to provide a noise-free supply voltage to V_{REFIN} . To use the full dynamic range of the DAC104S085, the supply pin (V_A) and V_{REFIN} can be connected together and share the same supply voltage. Figure 36 uses an LM4050 as a voltage reference source for the DAC104S085.

9.2.2 Detailed Design Procedure

Available with accuracy of 0.44%, the LM4050 shunt reference is also a good choice as a reference for the DAC104S085. It is available in 4.096-V and 5-V versions and comes in a space-saving, 3-pin SOT-23.

The minimum resistor value in the circuit of Figure 36 must be chosen so that the maximum current through the LM4050 does not exceed its 15-mA rating. The conditions for maximum current include the input voltage at its maximum, the LM4050 voltage at its minimum, and the DAC104S085 drawing zero current. The maximum resistor value must allow the LM4050 to draw more than its minimum current for regulation plus the maximum DAC104S085 current in full operation. The conditions for minimum current include the input voltage at its minimum, the LM4050 voltage at its maximum, the resistor value at its maximum due to tolerance, and the DAC104S085 draws its maximum current. Equation 4 and Equation 5 summarize these conditions.

$$R(\min) = (V_{IN}(\max) - V_Z(\min)) / I_Z(\max) \quad (4)$$

and

$$R(\max) = (V_{IN}(\min) - V_Z(\max)) / (I_{DAC}(\max) + I_Z(\min))$$

where

- $V_Z(\min)$ and $V_Z(\max)$ are the nominal LM4050 output voltages \pm the LM4050 output tolerance over temperature
 - $I_Z(\max)$ is the maximum allowable current through the LM4050
 - $I_Z(\min)$ is the minimum current required by the LM4050 for proper regulation
 - $I_{DAC}(\max)$ is the maximum DAC104S085 supply current.
- (5)

Typical Application (continued)

9.2.3 Application Curves

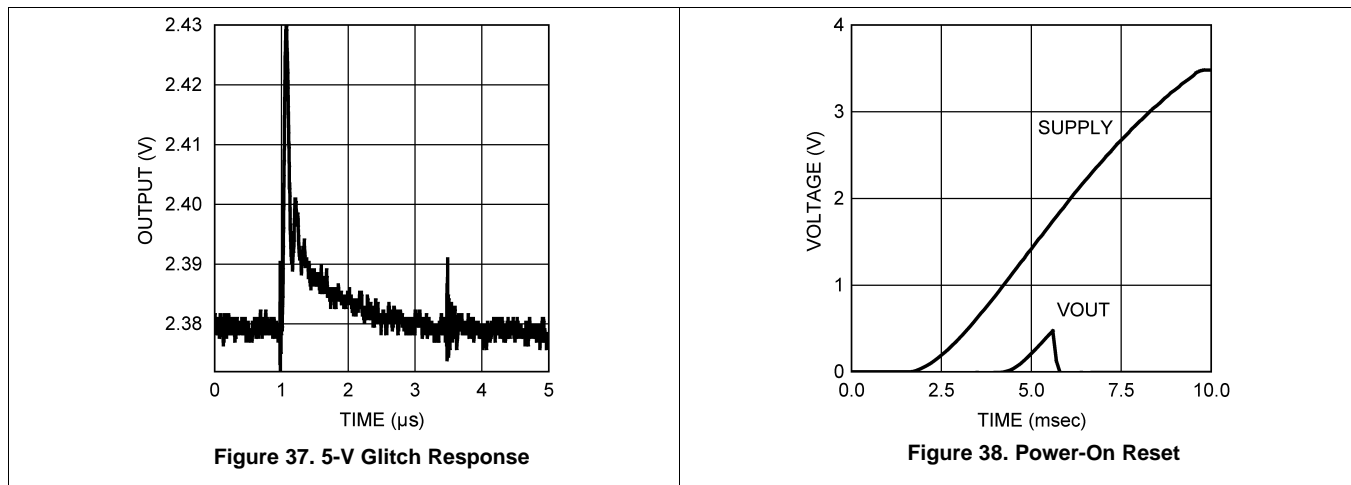

10 Power Supply Recommendations

The DAC104S085 power supply should be bypassed with a 10- μ F and a 0.1- μ F capacitor as close as possible to the device with the 0.1 μ F right at the device supply pin. The 10- μ F capacitor should be a tantalum type and the 0.1- μ F capacitor must be a low ESL, low ESR type. The power supply for the DAC104S085 must only be used for analog circuits.

11 Layout

11.1 Layout Guidelines

For best accuracy and minimum noise, the printed-circuit board containing the DAC104S085 must have separate analog and digital areas. The areas are defined by the locations of the analog and digital power planes. Both of these planes should be located in the same board layer. There must be a single ground plane. A single ground plane is preferred if digital return current does not flow through the analog ground area. Frequently a single ground plane design uses a *fencing* technique to prevent the mixing of analog and digital ground current. Separate ground planes must only be used when the fencing technique is inadequate. The separate ground planes must be connected in one place, preferably near the DAC104S085. Special care is required to ensure that digital signals with fast edge rates do not pass over split ground planes. They must always have a continuous return path below their traces.

Avoid crossover of analog and digital signals and keep the clock and data lines on the component side of the board. The clock and data lines must have controlled impedances.

11.2 Layout Example

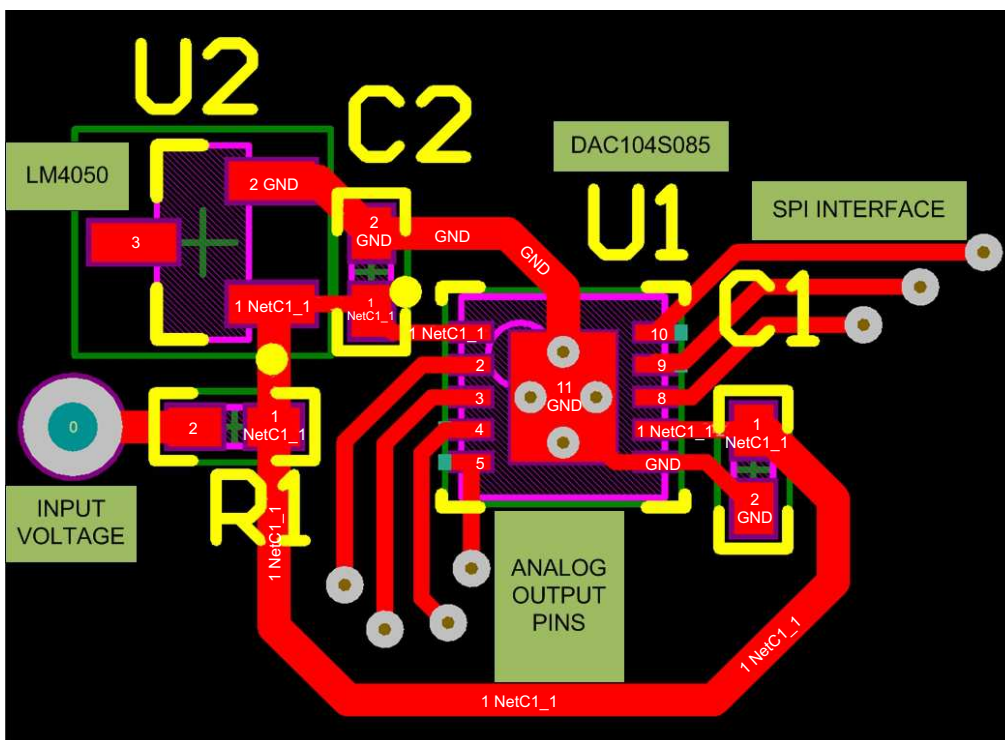

Figure 39. DAC104S085 Layout Example

12 Device and Documentation Support

12.1 Device Support

12.1.1 Device Nomenclature

12.1.1.1 Specification Definitions

DIFFERENTIAL NON-LINEARITY (DNL) is the measure of the maximum deviation from the ideal step size of 1 LSB, which is $V_{REF} / 1024 = V_A / 1024$.

DAC-to-DAC CROSSTALK is the glitch impulse transferred to a DAC output in response to a full-scale change in the output of another DAC.

DIGITAL CROSSTALK is the glitch impulse transferred to a DAC output at mid-scale in response to a full-scale change in the input register of another DAC.

DIGITAL FEEDTHROUGH is a measure of the energy injected into the analog output of the DAC from the digital inputs when the DAC outputs are not updated. It is measured with a full-scale code change on the data bus.

FULL-SCALE ERROR is the difference between the actual output voltage with a full scale code (3FFh) loaded into the DAC and the value of $V_A \times 1023 / 1024$.

GAIN ERROR is the deviation from the ideal slope of the transfer function. It can be calculated from Zero and Full-Scale Errors as $GE = FSE - ZE$, where GE is Gain error, FSE is Full-Scale Error and ZE is Zero Error.

GLITCH IMPULSE is the energy injected into the analog output when the input code to the DAC register changes. It is specified as the area of the glitch in nanovolt-seconds.

INTEGRAL NON-LINEARITY (INL) is a measure of the deviation of each individual code from a straight line through the input to output transfer function. The deviation of any given code from this straight line is measured from the center of that code value. The end point method is used. INL for this product is specified over a limited range.

LEAST SIGNIFICANT BIT (LSB) is the bit that has the smallest value or weight of all bits in a word. This value is $LSB = V_{REF} / 2^n$

where

- where V_{REF} is the supply voltage for this product, and "n" is the DAC resolution in bits, which is 10 for the DAC104S085. (6)

MAXIMUM LOAD CAPACITANCE is the maximum capacitance that can be driven by the DAC with output stability maintained.

MONOTONICITY is the condition of being monotonic, where the DAC has an output that never decreases when the input code increases.

MOST SIGNIFICANT BIT (MSB) is the bit that has the largest value or weight of all bits in a word. Its value is 1/2 of V_A .

MULTIPLYING BANDWIDTH is the frequency at which the output amplitude falls 3dB below the input sine wave on V_{REFIN} with a full-scale code loaded into the DAC.

POWER EFFICIENCY is the ratio of the output current to the total supply current. The output current comes from the power supply. The difference between the supply and output currents is the power consumed by the device without a load.

SETTLING TIME is the time for the output to settle to within 1/2 LSB of the final value after the input code is updated.

TOTAL HARMONIC DISTORTION (THD) is the measure of the harmonics present at the output of the DACs with an ideal sine wave applied to V_{REFIN} . THD is measured in dB.

WAKE-UP TIME is the time for the output to exit power-down mode. This is the time from the falling edge of the 16th SCLK pulse to when the output voltage deviates from the power-down voltage of 0V.

Device Support (continued)

ZERO CODE ERROR is the output error, or voltage, present at the DAC output after a code of 000h has been entered.

12.2 Related Links

The table below lists quick access links. Categories include technical documents, support and community resources, tools and software, and quick access to sample or buy.

Table 3. Related Links

PARTS	PRODUCT FOLDER	SAMPLE & BUY	TECHNICAL DOCUMENTS	TOOLS & SOFTWARE	SUPPORT & COMMUNITY
DAC104S085	Click here	Click here	Click here	Click here	Click here
DAC104S085-Q1	Click here	Click here	Click here	Click here	Click here

12.3 Community Resources

The following links connect to TI community resources. Linked contents are provided "AS IS" by the respective contributors. They do not constitute TI specifications and do not necessarily reflect TI's views; see TI's [Terms of Use](#).

TI E2E™ Online Community *TI's Engineer-to-Engineer (E2E) Community*. Created to foster collaboration among engineers. At e2e.ti.com, you can ask questions, share knowledge, explore ideas and help solve problems with fellow engineers.

Design Support *TI's Design Support* Quickly find helpful E2E forums along with design support tools and contact information for technical support.

12.4 Trademarks

E2E is a trademark of Texas Instruments.
All other trademarks are the property of their respective owners.

12.5 Electrostatic Discharge Caution



This integrated circuit can be damaged by ESD. Texas Instruments recommends that all integrated circuits be handled with appropriate precautions. Failure to observe proper handling and installation procedures can cause damage.

ESD damage can range from subtle performance degradation to complete device failure. Precision integrated circuits may be more susceptible to damage because very small parametric changes could cause the device not to meet its published specifications.

12.6 Glossary

[SLYZ022](#) — *TI Glossary*.

This glossary lists and explains terms, acronyms, and definitions.

13 Mechanical, Packaging, and Orderable Information

The following pages include mechanical, packaging, and orderable information. This information is the most current data available for the designated devices. This data is subject to change without notice and revision of this document. For browser-based versions of this data sheet, refer to the left-hand navigation.

PACKAGING INFORMATION

Orderable Device	Status (1)	Package Type	Package Drawing	Pins	Package Qty	Eco Plan (2)	Lead/Ball Finish (6)	MSL Peak Temp (3)	Op Temp (°C)	Device Marking (4/5)	Samples
DAC104S085CIMM/NOPB	ACTIVE	VSSOP	DGS	10	1000	Green (RoHS & no Sb/Br)	CU SN	Level-1-260C-UNLIM	-40 to 105	X68C	Samples
DAC104S085CIMMX/NOPB	ACTIVE	VSSOP	DGS	10	3500	Green (RoHS & no Sb/Br)	CU SN	Level-1-260C-UNLIM	-40 to 105	X68C	Samples
DAC104S085CISD/NOPB	ACTIVE	WSOP	DSC	10	1000	Green (RoHS & no Sb/Br)	CU SN	Level-1-260C-UNLIM	-40 to 105	X69C	Samples
DAC104S085CISDX/NOPB	ACTIVE	WSOP	DSC	10	4500	Green (RoHS & no Sb/Br)	CU SN	Level-1-260C-UNLIM	-40 to 105	X69C	Samples
DAC104S085QIMM/NOPB	ACTIVE	VSSOP	DGS	10	1000	Green (RoHS & no Sb/Br)	CU SN	Level-1-260C-UNLIM	-40 to 125	X68Q	Samples
DAC104S085QIMMX/NOPB	ACTIVE	VSSOP	DGS	10	3500	Green (RoHS & no Sb/Br)	CU SN	Level-1-260C-UNLIM	-40 to 125	X68Q	Samples

(1) The marketing status values are defined as follows:

ACTIVE: Product device recommended for new designs.

LIFEBUY: TI has announced that the device will be discontinued, and a lifetime-buy period is in effect.

NRND: Not recommended for new designs. Device is in production to support existing customers, but TI does not recommend using this part in a new design.

PREVIEW: Device has been announced but is not in production. Samples may or may not be available.

OBSELETE: TI has discontinued the production of the device.

(2) Eco Plan - The planned eco-friendly classification: Pb-Free (RoHS), Pb-Free (RoHS Exempt), or Green (RoHS & no Sb/Br) - please check <http://www.ti.com/productcontent> for the latest availability information and additional product content details.

TBD: The Pb-Free/Green conversion plan has not been defined.

Pb-Free (RoHS): TI's terms "Lead-Free" or "Pb-Free" mean semiconductor products that are compatible with the current RoHS requirements for all 6 substances, including the requirement that lead not exceed 0.1% by weight in homogeneous materials. Where designed to be soldered at high temperatures, TI Pb-Free products are suitable for use in specified lead-free processes.

Pb-Free (RoHS Exempt): This component has a RoHS exemption for either 1) lead-based flip-chip solder bumps used between the die and package, or 2) lead-based die adhesive used between the die and leadframe. The component is otherwise considered Pb-Free (RoHS compatible) as defined above.

Green (RoHS & no Sb/Br): TI defines "Green" to mean Pb-Free (RoHS compatible), and free of Bromine (Br) and Antimony (Sb) based flame retardants (Br or Sb do not exceed 0.1% by weight in homogeneous material)

(3) MSL, Peak Temp. - The Moisture Sensitivity Level rating according to the JEDEC industry standard classifications, and peak solder temperature.

(4) There may be additional marking, which relates to the logo, the lot trace code information, or the environmental category on the device.

(5) Multiple Device Markings will be inside parentheses. Only one Device Marking contained in parentheses and separated by a "~" will appear on a device. If a line is indented then it is a continuation of the previous line and the two combined represent the entire Device Marking for that device.

⁽⁶⁾ Lead/Ball Finish - Orderable Devices may have multiple material finish options. Finish options are separated by a vertical ruled line. Lead/Ball Finish values may wrap to two lines if the finish value exceeds the maximum column width.

Important Information and Disclaimer:The information provided on this page represents TI's knowledge and belief as of the date that it is provided. TI bases its knowledge and belief on information provided by third parties, and makes no representation or warranty as to the accuracy of such information. Efforts are underway to better integrate information from third parties. TI has taken and continues to take reasonable steps to provide representative and accurate information but may not have conducted destructive testing or chemical analysis on incoming materials and chemicals. TI and TI suppliers consider certain information to be proprietary, and thus CAS numbers and other limited information may not be available for release.

In no event shall TI's liability arising out of such information exceed the total purchase price of the TI part(s) at issue in this document sold by TI to Customer on an annual basis.

OTHER QUALIFIED VERSIONS OF DAC104S085, DAC104S085-Q1 :

- Catalog: [DAC104S085](#)
- Automotive: [DAC104S085-Q1](#)

NOTE: Qualified Version Definitions:

- Catalog - TI's standard catalog product
- Automotive - Q100 devices qualified for high-reliability automotive applications targeting zero defects

TAPE AND REEL INFORMATION

QUADRANT ASSIGNMENTS FOR PIN 1 ORIENTATION IN TAPE

*All dimensions are nominal

Device	Package Type	Package Drawing	Pins	SPQ	Reel Diameter (mm)	Reel Width W1 (mm)	A0 (mm)	B0 (mm)	K0 (mm)	P1 (mm)	W (mm)	Pin1 Quadrant
DAC104S085CIMM/NOPB	VSSOP	DGS	10	1000	178.0	12.4	5.3	3.4	1.4	8.0	12.0	Q1
DAC104S085CIMMX/NOPB	VSSOP	DGS	10	3500	330.0	12.4	5.3	3.4	1.4	8.0	12.0	Q1
DAC104S085CISD/NOPB	WSON	DSC	10	1000	178.0	12.4	3.3	3.3	1.0	8.0	12.0	Q1
DAC104S085CISDX/NOPB	WSON	DSC	10	4500	330.0	12.4	3.3	3.3	1.0	8.0	12.0	Q1
DAC104S085QIMM/NOPB	VSSOP	DGS	10	1000	178.0	12.4	5.3	3.4	1.4	8.0	12.0	Q1
DAC104S085QIMMX/NOPB	VSSOP	DGS	10	3500	330.0	12.4	5.3	3.4	1.4	8.0	12.0	Q1

TAPE AND REEL BOX DIMENSIONS

*All dimensions are nominal

Device	Package Type	Package Drawing	Pins	SPQ	Length (mm)	Width (mm)	Height (mm)
DAC104S085CIMM/NOPB	VSSOP	DGS	10	1000	210.0	185.0	35.0
DAC104S085CIMMX/NOP B	VSSOP	DGS	10	3500	367.0	367.0	35.0
DAC104S085CISD/NOPB	WSON	DSC	10	1000	210.0	185.0	35.0
DAC104S085CISDX/NOP B	WSON	DSC	10	4500	367.0	367.0	35.0
DAC104S085QIMM/NOPB	VSSOP	DGS	10	1000	210.0	185.0	35.0
DAC104S085QIMMX/NOP B	VSSOP	DGS	10	3500	367.0	367.0	35.0

DGS0010A



PACKAGE OUTLINE

VSSOP - 1.1 mm max height

SMALL OUTLINE PACKAGE



4221984/A 05/2015

NOTES:

1. All linear dimensions are in millimeters. Any dimensions in parenthesis are for reference only. Dimensioning and tolerancing per ASME Y14.5M.
2. This drawing is subject to change without notice.
3. This dimension does not include mold flash, protrusions, or gate burrs. Mold flash, protrusions, or gate burrs shall not exceed 0.15 mm per side.
4. This dimension does not include interlead flash. Interlead flash shall not exceed 0.25 mm per side.
5. Reference JEDEC registration MO-187, variation BA.

EXAMPLE BOARD LAYOUT

DGS0010A

VSSOP - 1.1 mm max height

SMALL OUTLINE PACKAGE



LAND PATTERN EXAMPLE
SCALE:10X

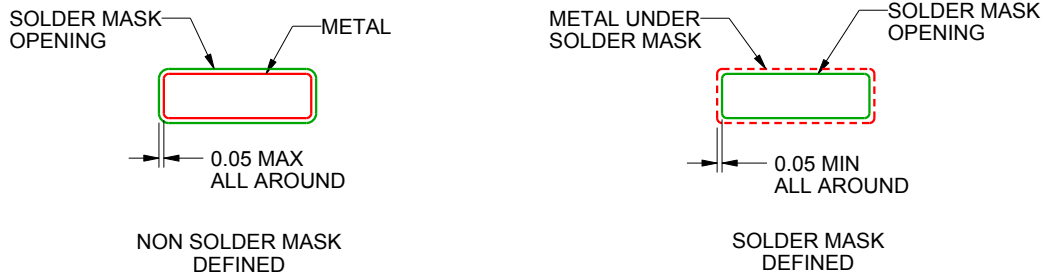

SOLDER MASK DETAILS
NOT TO SCALE

4221984/A 05/2015

NOTES: (continued)

- 6. Publication IPC-7351 may have alternate designs.
- 7. Solder mask tolerances between and around signal pads can vary based on board fabrication site.

EXAMPLE STENCIL DESIGN

DGS0010A

VSSOP - 1.1 mm max height

SMALL OUTLINE PACKAGE



SOLDER PASTE EXAMPLE
BASED ON 0.125 mm THICK STENCIL
SCALE:10X

4221984/A 05/2015

NOTES: (continued)

8. Laser cutting apertures with trapezoidal walls and rounded corners may offer better paste release. IPC-7525 may have alternate design recommendations.
9. Board assembly site may have different recommendations for stencil design.

IMPORTANT NOTICE AND DISCLAIMER

TI PROVIDES TECHNICAL AND RELIABILITY DATA (INCLUDING DATASHEETS), DESIGN RESOURCES (INCLUDING REFERENCE DESIGNS), APPLICATION OR OTHER DESIGN ADVICE, WEB TOOLS, SAFETY INFORMATION, AND OTHER RESOURCES "AS IS" AND WITH ALL FAULTS, AND DISCLAIMS ALL WARRANTIES, EXPRESS AND IMPLIED, INCLUDING WITHOUT LIMITATION ANY IMPLIED WARRANTIES OF MERCHANTABILITY, FITNESS FOR A PARTICULAR PURPOSE OR NON-INFRINGEMENT OF THIRD PARTY INTELLECTUAL PROPERTY RIGHTS.



These resources are intended for skilled developers designing with TI products. You are solely responsible for (1) selecting the appropriate TI products for your application, (2) designing, validating and testing your application, and (3) ensuring your application meets applicable standards, and any other safety, security, or other requirements. These resources are subject to change without notice. TI grants you permission to use these resources only for development of an application that uses the TI products described in the resource. Other reproduction and display of these resources is prohibited. No license is granted to any other TI intellectual property right or to any third party intellectual property right. TI disclaims responsibility for, and you will fully indemnify TI and its representatives against, any claims, damages, costs, losses, and liabilities arising out of your use of these resources.

TI's products are provided subject to TI's Terms of Sale (www.ti.com/legal/termsofsale.html) or other applicable terms available either on ti.com or provided in conjunction with such TI products. TI's provision of these resources does not expand or otherwise alter TI's applicable warranties or warranty disclaimers for TI products.

Mailing Address: Texas Instruments, Post Office Box 655303, Dallas, Texas 75265
Copyright © 2018, Texas Instruments Incorporated

Looking for pricing, stock, or lifecycle information?

Click below to explore more details on WIN SOURCE:

-  [View DAC104S085CIMMX/NOPB on WIN SOURCE](#)
-  [Texas Instruments](#) Information

Optimize Your Supply Chain with WIN SOURCE Solutions

-  Global Sourcing Solution
-  Obsolete Management
-  Cost Control Management
-  Shortage Management
-  Alternative Solution
-  Excess Inventory Management