

FEATURES

Ideal for CATV and terrestrial applications

2.4 GHz, -3 dB bandwidth

1 dB flatness: 54 MHz to 865 MHz

Low noise figure: 4.6 dB

Low distortion

Composite second-order (CSO): -62 dBc

Composite triple beat (CTB): -72 dBc

Nominal 3 dB gain per output channel

25 dB output-to-output isolation, 50 MHz to 1000 MHz

75 Ω input and outputs

Small package size: 16-lead, 3 mm \times 3 mm LFCSP

APPLICATIONS

Set-top boxes

Residential gateways

CATV distribution systems

Splitter modules

Digital cable ready (DCR) TVs

GENERAL DESCRIPTION

The ADA4304-3/ADA4304-4 are 75 Ω active splitters for use in applications where a lossless signal split is required. Typical applications include multituner digital set-top boxes, cable splitter modules, multituners/digital cable ready (DCR) televisions, and home gateways where traditional solutions require discrete passive splitter modules with separate fixed gain amplifiers.

Rev. A

[Document Feedback](#)

Information furnished by Analog Devices is believed to be accurate and reliable. However, no responsibility is assumed by Analog Devices for its use, nor for any infringements of patents or other rights of third parties that may result from its use. Specifications subject to change without notice. No license is granted by implication or otherwise under any patent or patent rights of Analog Devices. Trademarks and registered trademarks are the property of their respective owners.

FUNCTIONAL BLOCK DIAGRAMS

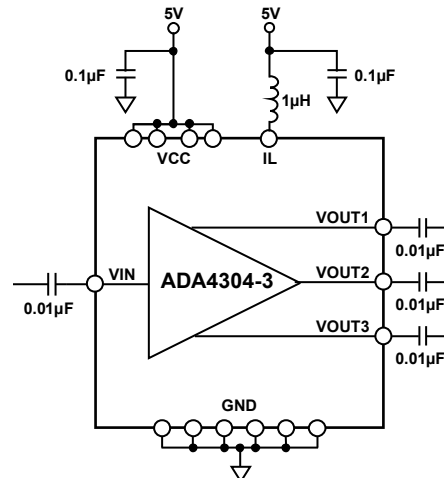

Figure 1.

07082-001

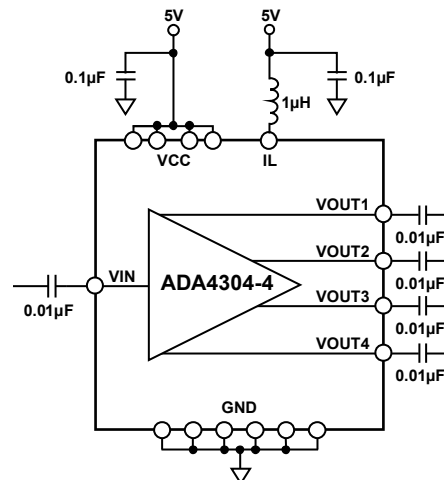

Figure 2.

07082-002

The ADA4304-3/ADA4304-4 are fabricated using the Analog Devices, Inc., proprietary silicon germanium (SiGe), complementary bipolar process, enabling them to achieve very low levels of distortion with a noise figure of 4.6 dB. The parts provide low cost alternatives that simplify designs and improve system performance by integrating a signal splitter element and a gain block into a single IC. The ADA4304-3/ADA4304-4 are available in a 16-lead LFCSP and operate in the extended industrial temperature range of -40°C to $+85^{\circ}\text{C}$.

TABLE OF CONTENTS

| | | | |
|--------------------------------|---|--|----|
| Features | 1 | Pin Configurations and Function Descriptions | 5 |
| Applications..... | 1 | Typical Performance Characteristics | 6 |
| Functional Block Diagrams..... | 1 | Test Circuits..... | 9 |
| General Description | 1 | Applications..... | 10 |
| Revision History | 2 | Circuit Description | 10 |
| Specifications..... | 3 | Outline Dimensions | 11 |
| Absolute Maximum Ratings..... | 4 | Ordering Guide | 11 |
| Thermal Resistance | 4 | | |
| ESD Caution..... | 4 | | |

REVISION HISTORY

7/2016—Rev. 0 to Rev. A

| | |
|---|----|
| Changes to Figure 4, Figure 5, Table 4, and Table 5..... | 5 |
| Deleted Evaluation Boards Section, RF Layout Considerations Section, Power Supply Section, and Figure 21; Renumbered Sequentially | 10 |
| Deleted Figure 22 and Figure 23..... | 11 |
| Updated Outline Dimensions | 12 |
| Changes to Ordering Guide | 12 |

11/2007—Revision 0: Initial Version

SPECIFICATIONS

$V_{CC} = 5\text{ V}$, $75\ \Omega$ system, $T_A = 25^\circ\text{C}$, unless otherwise noted.

Table 1.

| Parameter | Conditions | ADA4304-3 | | | ADA4304-4 | | | Unit |
|-------------------------------------|---|-----------|------|------|-----------|-----|------|------|
| | | Min | Typ | Max | Min | Typ | Max | |
| DYNAMIC PERFORMANCE | | | | | | | | |
| | See Figure 19 for test circuit | | | | | | | |
| Bandwidth (–3 dB) | | | 2400 | | 2400 | | | MHz |
| Frequency Range | | 54 | | 865 | 54 | | 865 | MHz |
| Gain | $f = 100\text{ MHz}$ | | 3.3 | | 2.9 | | | dB |
| Gain Flatness | 54 MHz to 865 MHz | | 1.0 | | 1.0 | | | dB |
| NOISE/DISTORTION PERFORMANCE | | | | | | | | |
| Noise Figure ¹ | @ 54 MHz | | 4.0 | | 4.0 | | | dB |
| | @ 550 MHz | | 4.6 | | 4.6 | | | dB |
| | @ 865 MHz | | 4.8 | | 4.8 | | | dB |
| Output IP3 | $f_1 = 97.25\text{ MHz}$, $f_2 = 103.25\text{ MHz}$ | | 26 | | 26 | | | dBm |
| Output IP2 | $f_1 = 97.25\text{ MHz}$, $f_2 = 103.25\text{ MHz}$ | | 43 | | 43 | | | dBm |
| Composite Triple Beat (CTB) | 135 channels, 15 dBmV/channel, $f = 865\text{ MHz}$ | | –72 | | –72 | | | dBc |
| Composite Second Order (CSO) | 135 channels, 15 dBmV/channel, $f = 865\text{ MHz}$ | | –62 | | –62 | | | dBc |
| Cross Modulation (CXM) | 135 channels, 15 dBmV/channel, 100% modulation @ 15.75 kHz, $f = 865\text{ MHz}$ | | –68 | | –68 | | | dBc |
| INPUT CHARACTERISTICS | | | | | | | | |
| Input Return Loss | See Figure 19 for test circuit | | | | | | | |
| | @ 54 MHz | | –17 | –13 | –18 | –14 | | dB |
| | @ 550 MHz | | –22 | –16 | –21 | –15 | | dB |
| | @ 865 MHz | | –12 | –8 | –12 | –8 | | dB |
| Output-to-Input Isolation | Any output, 54 MHz to 865 MHz | | | | | | | |
| | @ 54 MHz | | –33 | –30 | –33 | –31 | | dB |
| | @ 550 MHz | | –33 | –30 | –33 | –31 | | dB |
| | @ 865 MHz | | –34 | –31 | –35 | –32 | | dB |
| OUTPUT CHARACTERISTICS | | | | | | | | |
| Output Return Loss | See Figure 19 and Figure 20 for test circuits | | | | | | | |
| | Any output, 54 MHz to 865 MHz | | | | | | | |
| | @ 54 MHz | | –21 | –17 | –21 | –17 | | dB |
| | @ 550 MHz | | –16 | –11 | –17 | –12 | | dB |
| | @ 865 MHz | | –14 | –9 | –14 | –9 | | dB |
| Output-to-Output Isolation | Any output, 54 MHz to 865 MHz | | | | | | | dB |
| | @ 54 MHz | | –26 | | –26 | | | dB |
| | @ 550 MHz | | –25 | | –25 | | | dB |
| | @ 865 MHz | | –25 | | –25 | | | dB |
| 1 dB Compression (P1dB) | Output referred, $f = 100\text{ MHz}$ | | 9.0 | | 8.7 | | | dBm |
| POWER SUPPLY | | | | | | | | |
| Nominal Supply Voltage | | 4.75 | 5.0 | 5.25 | 4.75 | 5.0 | 5.25 | V |
| Quiescent Supply Current | | | 92 | 105 | | 92 | 105 | mA |

¹ Characterized with 50 Ω noise figure analyzer.

ABSOLUTE MAXIMUM RATINGS

Table 2.

| Parameter | Rating |
|--------------------------------------|-----------------|
| Supply Voltage | 5.5 V |
| Power Dissipation | See Figure 3 |
| Storage Temperature Range | -65°C to +125°C |
| Operating Temperature Range | -40°C to +85°C |
| Lead Temperature (Soldering, 10 sec) | 300°C |
| Junction Temperature | 150°C |

Stresses at or above those listed under Absolute Maximum Ratings may cause permanent damage to the product. This is a stress rating only; functional operation of the product at these or any other conditions above those indicated in the operational section of this specification is not implied. Operation beyond the maximum operating conditions for extended periods may affect product reliability.

THERMAL RESISTANCE

θ_{JA} is specified for the device (including exposed pad) soldered to a high thermal conductivity 4-layer (2s2p) circuit board, as described in EIA/JESD 51-7.

Table 3. Thermal Resistance

| Package Type | θ_{JA} | Unit |
|-----------------------------|---------------|------|
| 16-Lead LFCSP (Exposed Pad) | 98 | °C/W |

Maximum Power Dissipation

The maximum safe power dissipation in the ADA4304-3/ADA4304-4 package is limited by the associated rise in junction temperature (T_j) on the die. At approximately 150°C, which is the glass transition temperature, the plastic changes its properties. Even temporarily exceeding this temperature limit can change the stresses that the package exerts on the die, permanently shifting the parametric performance. Exceeding a junction temperature of 150°C for an extended period can result in changes in the silicon devices, potentially causing failure.

The power dissipated in the package (P_D) is essentially equal to the quiescent power dissipation, that is, the supply voltage (V_s) times the quiescent current (I_s). In Table 1, the maximum power dissipation of the ADA4304-3/ADA4304-4 can be calculated as

$$P_{D(MAX)} = 5.25 \text{ V} \times 105 \text{ mA} = 551 \text{ mW}$$

Airflow increases heat dissipation, effectively reducing θ_{JA} . In addition, more metal directly in contact with the package leads/exposed pad from metal traces, through-holes, ground, and power planes reduces the θ_{JA} .

Figure 3 shows the maximum safe power dissipation in the package vs. the ambient temperature for the 16-lead LFCSP (98°C/W) on a JEDEC standard 4-layer board.

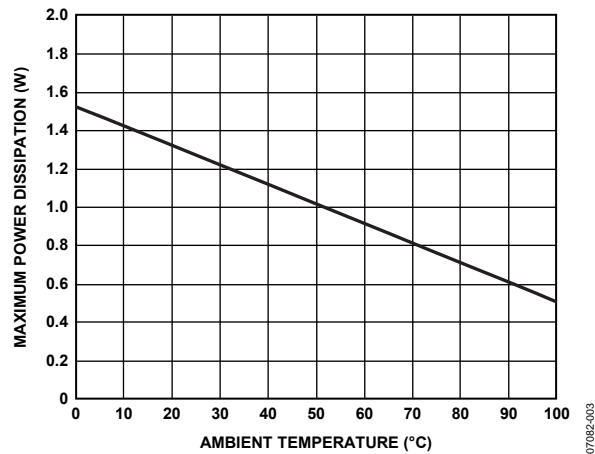

Figure 3. Maximum Power Dissipation vs. Temperature for a 4-Layer Board

ESD CAUTION



ESD (electrostatic discharge) sensitive device. Charged devices and circuit boards can discharge without detection. Although this product features patented or proprietary protection circuitry, damage may occur on devices subjected to high energy ESD. Therefore, proper ESD precautions should be taken to avoid performance degradation or loss of functionality.

PIN CONFIGURATIONS AND FUNCTION DESCRIPTIONS

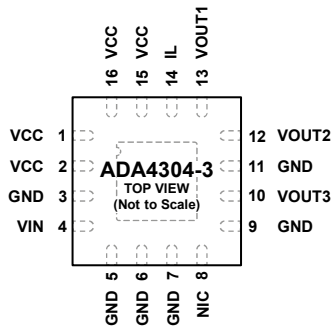

NOTES
 1. NIC = NO INTERNAL CONNECTION.
 2. EPAD SHOULD BE CONNECTED TO GND.

Figure 4. ADA4304-3 Pin Configuration

07082-004

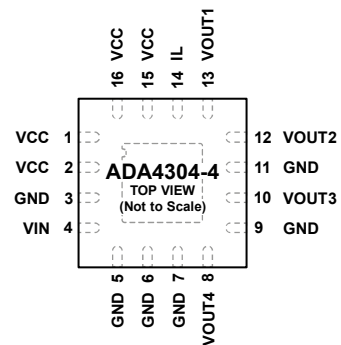

NOTES
 1. EPAD SHOULD BE CONNECTED TO GND.

Figure 5. ADA4304-4 Pin Configuration

07082-005

Table 4. ADA4304-3 Pin Function Descriptions

| Pin No. | Mnemonic | Description |
|------------------|----------|--|
| 1, 2, 15, 16 | VCC | Supply Pin. |
| 3, 5 to 7, 9, 11 | GND | Ground. |
| 4 | VIN | Input. |
| 8 | NIC | No Internal Connection. |
| 10 | VOUT3 | Output 3. |
| 12 | VOUT2 | Output 2. |
| 13 | VOUT1 | Output 1. |
| 14 | IL | Bias Pin. |
| | EPAD | Exposed Pad. Exposed pad should be connected to GND. |

Table 5. ADA4304-4 Pin Function Descriptions

| Pin No. | Mnemonic | Description |
|------------------|----------|--|
| 1, 2, 15, 16 | VCC | Supply Pin. |
| 3, 5 to 7, 9, 11 | GND | Ground. |
| 4 | VIN | Input. |
| 8 | VOUT4 | Output 4. |
| 10 | VOUT3 | Output 3. |
| 12 | VOUT2 | Output 2. |
| 13 | VOUT1 | Output 1. |
| 14 | IL | Bias Pin. |
| | EPAD | Exposed Pad. Exposed pad should be connected to GND. |

TYPICAL PERFORMANCE CHARACTERISTICS

$V_{CC} = 5\text{ V}$, $75\ \Omega$ system, $T_A = 25^\circ\text{C}$, unless otherwise noted.

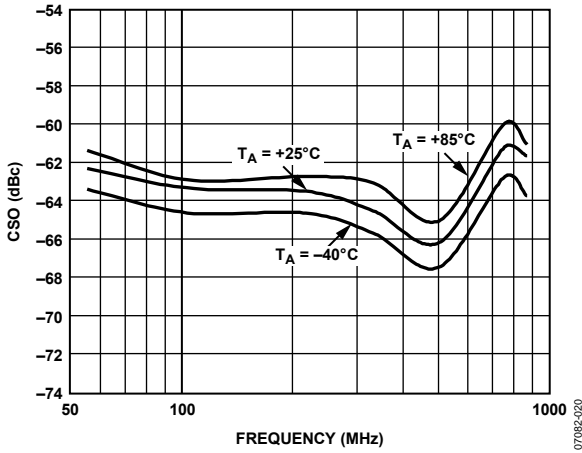

Figure 6. Composite Second Order (CSO) vs. Frequency

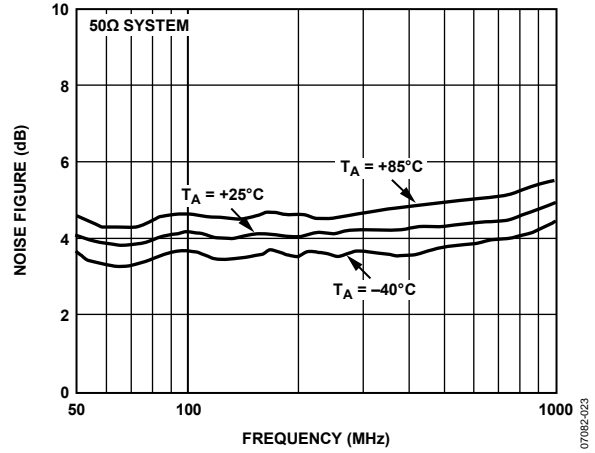

Figure 9. Noise Figure vs. Frequency

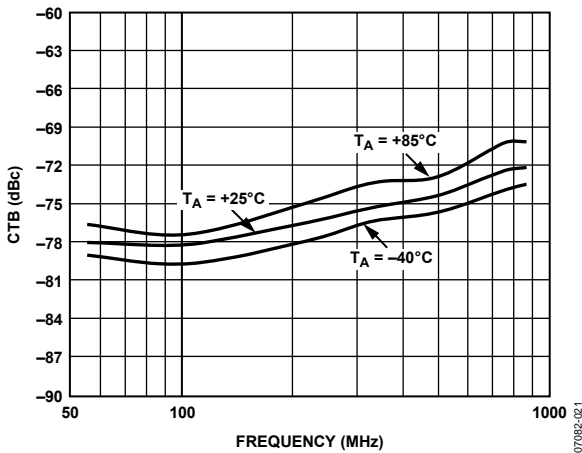

Figure 7. Composite Triple Beat (CTB) vs. Frequency

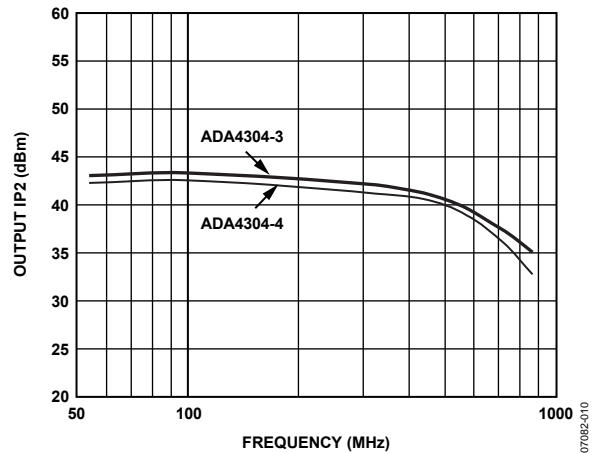

Figure 10. Output IP2 vs. Frequency

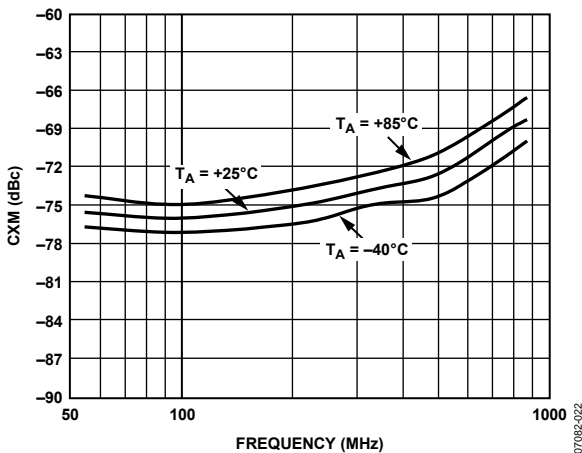

Figure 8. Cross Modulation (CXM) vs. Frequency

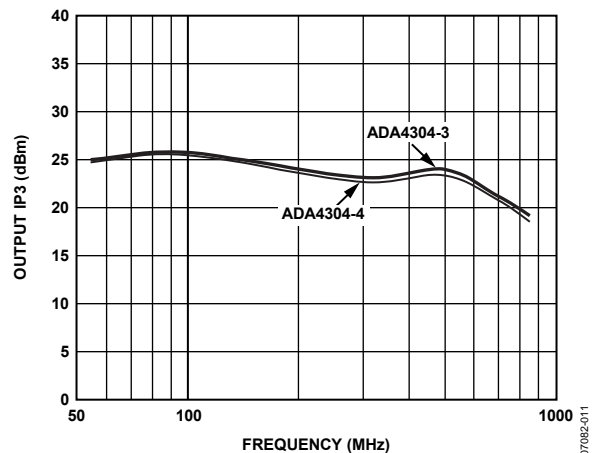

Figure 11. Output IP3 vs. Frequency

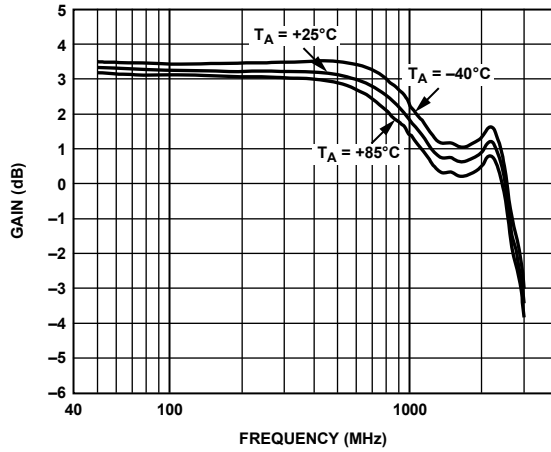

Figure 12. ADA4304-3 Gain vs. Frequency

07082-024

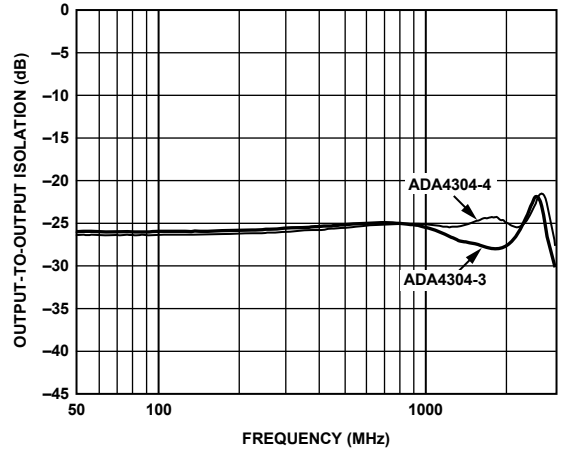

Figure 15. Output-to-Output Isolation vs. Frequency

07082-014

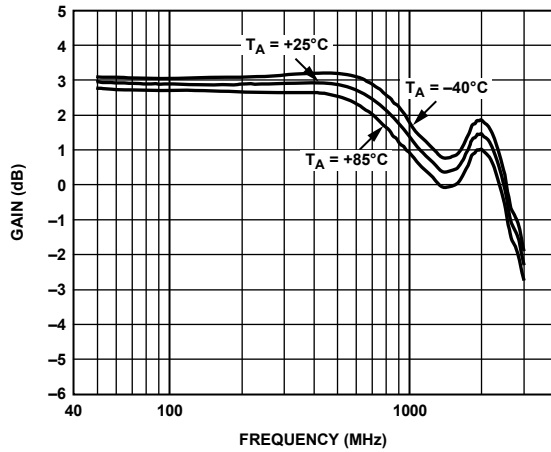

Figure 13. ADA4304-4 Gain vs. Frequency

07082-025

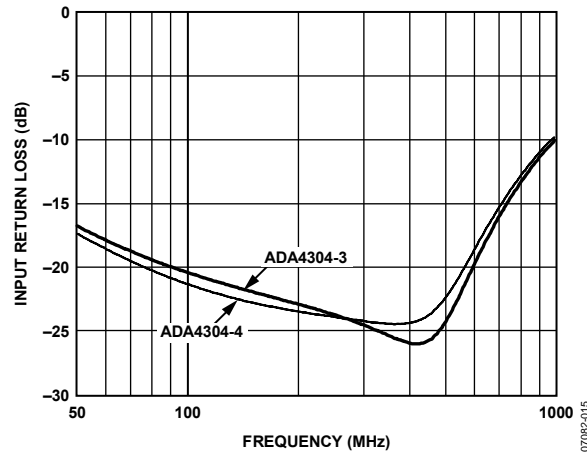

Figure 16. Input Return Loss vs. Frequency

07082-015

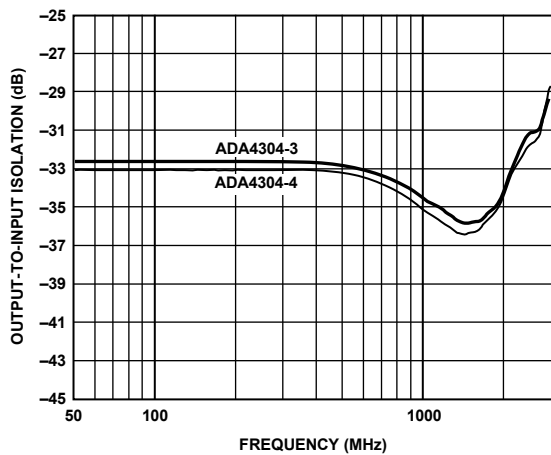

Figure 14. Output-to-Input Isolation vs. Frequency

07082-013

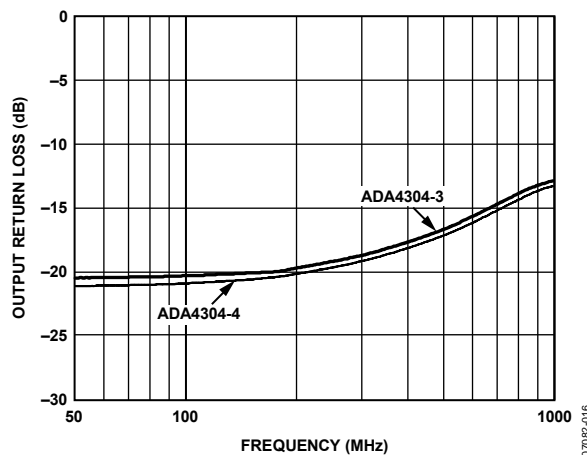

Figure 17. Output Return Loss vs. Frequency

07082-016

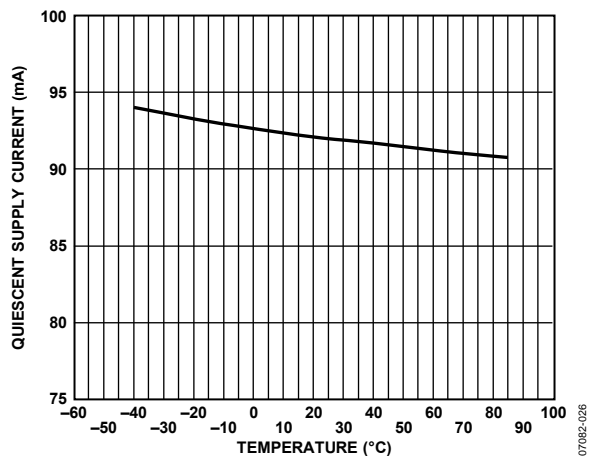

Figure 18. Quiescent Supply Current vs. Temperature

071082-026

TEST CIRCUITS

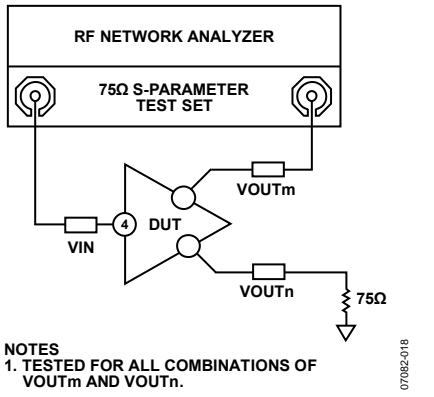

Figure 19. Test Circuit for Transmission, Isolation, and Reflection Measurements

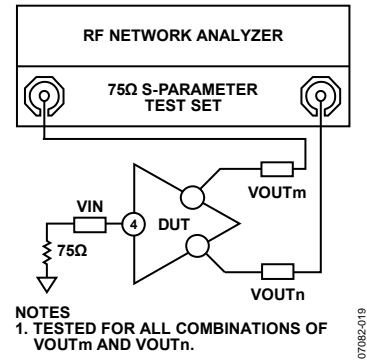

Figure 20. Test Circuit for Output-to-Output Isolation Measurements

APPLICATIONS

The [ADA4304-3/ADA4304-4](#) active splitters are primarily intended for use in the downstream path of television set-top boxes (STBs) that contain multiple tuners. They are typically located directly after the diplexer in a bidirectional CATV customer premise unit. The [ADA4304-3/ADA4304-4](#) provide a single-ended input and three or four single-ended outputs that allow the delivery of the RF signal to multiple signal paths. These paths can include, but are not limited to, a main picture tuner, the picture-in-picture (PIP) tuner, an out-of-band (OOB) tuner, a digital video recorder (DVR), and a cable modem (CM).

The [ADA4304-3/ADA4304-4](#) exhibit composite second-order (CSO) and composite triple beat (CTB) products that are -62 dBc and -72 dBc, respectively. The use of the SiGe bipolar process also allows the [ADA4304-3/ADA4304-4](#) to achieve a noise figure (NF) of 4.6 dB at 550 MHz.

CIRCUIT DESCRIPTION

The [ADA4304-3/ADA4304-4](#) consist of a low noise buffer amplifier followed by a resistive power divider. This arrangement provides 3.3 dB ([ADA4304-3](#)) or 2.9 dB ([ADA4304-4](#)) of gain relative to the RF signal present at the input of the device. The input and each output must be properly matched to a $75\ \Omega$ environment for distortion and noise performance to match the data sheet specifications. AC coupling capacitors of $0.01\ \mu\text{F}$ are recommended for the input and outputs.

A $1\ \mu\text{H}$ RF choke (Coilcraft chip inductor 0805LS-102X) is required to correctly bias the internal nodes of the [ADA4304-3/ADA4304-4](#). It should be connected between the 5 V supply and the IL pin (Pin 14). The choke should be placed as close as possible to the [ADA4304-3/ADA4304-4](#) to minimize parasitic capacitance on the IL pin, which is critical for achieving the specified bandwidth and flatness.

OUTLINE DIMENSIONS

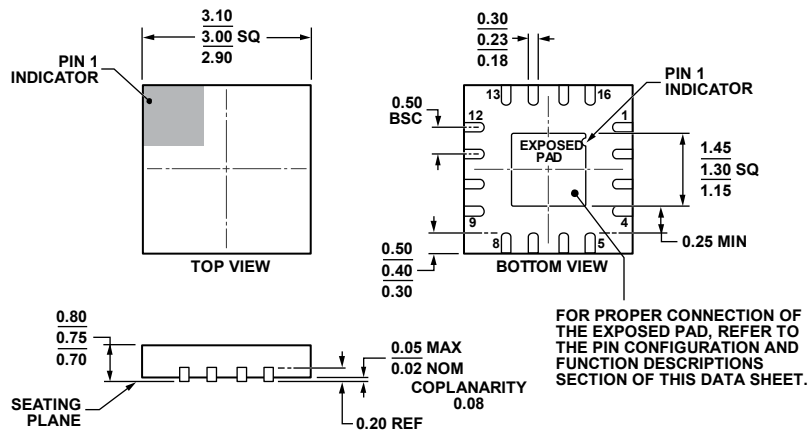

COMPLIANT TO JEDEC STANDARDS MO-220-WEED.

Figure 21. 16-Lead Lead Frame Chip Scale Package [LFCS]
 3 mm × 3 mm Body and 0.75 mm Package Height
 (CP-16-21)

Dimensions shown in millimeters

111808-A

ORDERING GUIDE

| Model ¹ | Temperature Range | Package Description | Package Option | Ordering Quantity | Branding |
|--------------------|-------------------|---------------------|----------------|-------------------|----------|
| ADA4304-3ACPZ-RL | -40°C to +85°C | 16-Lead LFCS | CP-16-21 | 5,000 | H16 |
| ADA4304-3ACPZ-R7 | -40°C to +85°C | 16-Lead LFCS | CP-16-21 | 1,500 | H16 |
| ADA4304-3ACPZ-R2 | -40°C to +85°C | 16-Lead LFCS | CP-16-21 | 250 | H16 |
| ADA4304-4ACPZ-RL | -40°C to +85°C | 16-Lead LFCS | CP-16-21 | 5,000 | H10 |
| ADA4304-4ACPZ-R7 | -40°C to +85°C | 16-Lead LFCS | CP-16-21 | 1,500 | H10 |
| ADA4304-4ACPZ-R2 | -40°C to +85°C | 16-Lead LFCS | CP-16-21 | 250 | H10 |

¹ Z=RoHS Compliant Part

Looking for pricing, stock, or lifecycle information?

Click below to explore more details on WIN SOURCE:

 [View ADA4304-4ACPZ-EB on WIN SOURCE](#)

 [Analog Devices Inc. Information](#)

Optimize Your Supply Chain with WIN SOURCE Solutions

-  Global Sourcing Solution
-  Obsolete Management
-  Cost Control Management
-  Shortage Management
-  Alternative Solution
-  Excess Inventory Management