



**THE DATASHEET OF
AD8273-EVALZ**



FEATURES

- ±4000 V HBM ESD**
- Very low distortion**
 - 0.00025% THD + N (20 kHz)
 - 0.0015% THD + N (100 kHz)
- Drives 600 Ω loads**
- Two gain settings**
 - Gain of ½ (–6 dB)
 - Gain of 2 (+6 dB)
- 0.05% maximum gain error**
- 10 ppm/°C maximum gain drift**
- Excellent ac specifications**
 - 20 V/μs minimum slew rate
 - 800 ns to 0.01% settling time
- High accuracy dc performance**
 - 77 dB minimum CMRR
 - 700 μV maximum offset voltage
- 14-lead SOIC package**
- Supply current: 2.5 mA maximum per channel**
- Supply range: ±2.5 V to ±18 V**

APPLICATIONS

- ADC drivers
- High performance audio
- Instrumentation amplifier building blocks
- Level translators
- Automatic test equipment
- Sine/cosine encoders

GENERAL DESCRIPTION

The AD8273 is a low distortion, dual-channel amplifier with internal gain setting resistors. With no external components, it can be configured as a high performance difference amplifier ($G = \frac{1}{2}$ or 2), inverting amplifier ($G = \frac{1}{2}$ or 2), or noninverting amplifier ($G = 1\frac{1}{2}$ or 3).

The AD8273 operates on both single and dual supplies and only requires 2.5 mA maximum supply current for each amplifier. It is specified over the industrial temperature range of -40°C to $+85^{\circ}\text{C}$ and is fully RoHS compliant.

FUNCTIONAL BLOCK DIAGRAM

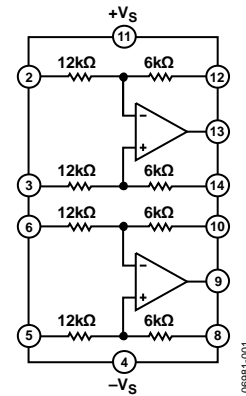

Figure 1.

Table 1. Difference Amplifiers by Category

Low Distortion	High Voltage	Single-Supply Unidirectional	Single-Supply Bidirectional
AD8270	AD628	AD8202	AD8205
AD8273	AD629	AD8203	AD8206
AD8274			AD8216
AMP03			

Rev. B

Information furnished by Analog Devices is believed to be accurate and reliable. However, no responsibility is assumed by Analog Devices for its use, nor for any infringements of patents or other rights of third parties that may result from its use. Specifications subject to change without notice. No license is granted by implication or otherwise under any patent or patent rights of Analog Devices. Trademarks and registered trademarks are the property of their respective owners.

TABLE OF CONTENTS

Features	1	Pin Configuration and Function Descriptions.....	5
Applications.....	1	Typical Performance Characteristics	6
Functional Block Diagram	1	Theory of Operation	12
General Description	1	Configurations.....	12
Revision History	2	Power Supplies.....	12
Specifications.....	3	Outline Dimensions	14
Absolute Maximum Ratings.....	4	Ordering Guide	14
Maximum Power Dissipation	4		
ESD Caution.....	4		

REVISION HISTORY

8/10—Rev. A to Rev. B

Changes to Data Sheet Title	1
Changes to THD + Noise (THD + N) Parameter, Gain Nonlinearity Parameter, and Offset vs. Power Supply Parameter, Table 2	3
Changed –12A Pin to –INA Pin, +12A Pin to +INA Pin, +12B Pin to INB Pin, –12B Pin to –INB Pin, +6B Pin to REFB Pin, –6B Pin to SENSEB Pin, –6A Pin to SENSEA Pin, and +6A Pin to REFA Pin Throughout	5
Changes to Figure 3 and Table 4.....	5

1/09—Rev. 0 to Rev. A

Changes to Product Title, Features Section, and Applications Section.....	1
Added Human Body Model (HBM) ESD Rating Parameter, Table 3	4
Changes to Figure 6 to Figure 9	6
Changes to Figure 10 to Figure 12.....	7
Changes to Figure 18.....	8
Deleted Figure 31; Renumbered Sequentially	10
Added Figure 31 to Figure 33; Renumbered Sequentially	10
Added Figure 34 to Figure 36.....	11

1/08—Revision 0: Initial Version

SPECIFICATIONS

$V_S = \pm 15\text{ V}$, $V_{REF} = 0\text{ V}$, $T_A = 25^\circ\text{C}$, $G = \frac{1}{2}$, $R_L = 2\text{ k}\Omega$, unless otherwise noted.

Table 2.

Parameter	Conditions	Min	Typ	Max	Unit
DYNAMIC PERFORMANCE					
Bandwidth			20		MHz
Slew Rate		20			V/ μs
Settling Time to 0.1%	10 V step on output, $C_L = 100\text{ pF}$		670	750	ns
Settling Time to 0.01%	10 V step on output, $C_L = 100\text{ pF}$		750	800	ns
Channel Separation	$f = 1\text{ kHz}$		130		dB
NOISE/DISTORTION¹					
THD + Noise (THD + N)	$f = 1\text{ kHz}$, $V_{OUT} = 10\text{ V p-p}$, $600\ \Omega$ load		0.00025		%
Noise Floor, RTO ²	20 kHz BW		-106		dBu
Output Voltage Noise (Referred to Output)	$f = 20\text{ Hz to } 20\text{ kHz}$		3.5		$\mu\text{V rms}$
	$f = 1\text{ kHz}$		26		$\text{nV}/\sqrt{\text{Hz}}$
GAIN					
Gain Error				0.05	%
Gain Drift	$-40^\circ\text{C to } +85^\circ\text{C}$		2	10	$\text{ppm}/^\circ\text{C}$
Gain Nonlinearity	$V_{OUT} = 10\text{ V p-p}$, $600\ \Omega$ load		2		ppm
INPUT CHARACTERISTICS					
Offset ³	Referred to output		100	700	μV
vs. Temperature	$-40^\circ\text{C to } +85^\circ\text{C}$		3		$\mu\text{V}/^\circ\text{C}$
vs. Power Supply	$V_S = \pm 2.5\text{ V to } \pm 18\text{ V}$		2	5	$\mu\text{V/V}$
Common-Mode Rejection Ratio	$V_{CM} = \pm 40\text{ V}$, $R_S = 0\ \Omega$, referred to input	77	86		dB
Input Voltage Range ⁴		$-3V_S + 4.5$		$+3V_S - 4.5$	V
Impedance ⁵					
Differential	$V_{CM} = 0\text{ V}$		36		$\text{k}\Omega$
Common Mode ⁶			9		$\text{k}\Omega$
OUTPUT CHARACTERISTICS					
Output Swing		$-V_S + 1.5$		$+V_S - 1.5$	V
Short-Circuit Current Limit	Sourcing		100		mA
	Sinking		60		mA
Capacitive Load Drive	$G = \frac{1}{2}$		200		pF
	$G = 2$		1200		pF
POWER SUPPLY					
Supply Current (per Amplifier)				2.5	mA
TEMPERATURE RANGE					
Specified Performance		-40		+85	$^\circ\text{C}$

¹ Includes amplifier voltage and current noise, as well as noise of internal resistors.

² dBu = $20 \log (V_{\text{rms}}/0.7746)$.

³ Includes input bias and offset current errors.

⁴ May also be limited by absolute maximum input voltage or by the output swing. See the Absolute Maximum Ratings section and Figure 9 through Figure 12 for details.

⁵ Internal resistors are trimmed to be ratio matched but have $\pm 20\%$ absolute accuracy.

⁶ Common mode is calculated looking into both inputs. Common-mode impedance looking into only one input is $18\text{ k}\Omega$.

ABSOLUTE MAXIMUM RATINGS

Table 3.

Parameter	Rating
Supply Voltage	± 18 V
Output Short-Circuit Current	Observe derating curve
Voltage at Any Input Pin	40 V
Differential Input Voltage	40 V
Current into Any Input Pin	3 mA
Human Body Model (HBM) ESD Rating	± 4000 V
Storage Temperature Range	-65°C to $+130^{\circ}\text{C}$
Specified Temperature Range	-40°C to $+85^{\circ}\text{C}$
Thermal Resistance	
θ_{JA}	$105^{\circ}\text{C}/\text{W}$
θ_{JC}	$36^{\circ}\text{C}/\text{W}$
Package Glass Transition Temperature (T_G)	150°C

Stresses above those listed under Absolute Maximum Ratings may cause permanent damage to the device. This is a stress rating only; functional operation of the device at these or any other conditions above those indicated in the operational section of this specification is not implied. Exposure to absolute maximum rating conditions for extended periods may affect device reliability.

MAXIMUM POWER DISSIPATION

The maximum safe power dissipation for the AD8273 is limited by the associated rise in junction temperature (T_J) on the die. At approximately 150°C , which is the glass transition temperature, the plastic changes its properties. Even temporarily exceeding this temperature limit may change the stresses that the package exerts on the die, permanently shifting the parametric performance of the amplifiers. Exceeding a temperature of 150°C for an extended period can result in a loss of functionality.

The AD8273 has built-in, short-circuit protection that limits the output current to approximately 100 mA (see Figure 2 for more information). While the short-circuit condition itself does not damage the part, the heat generated by the condition can cause the part to exceed its maximum junction temperature, with corresponding negative effects on reliability.

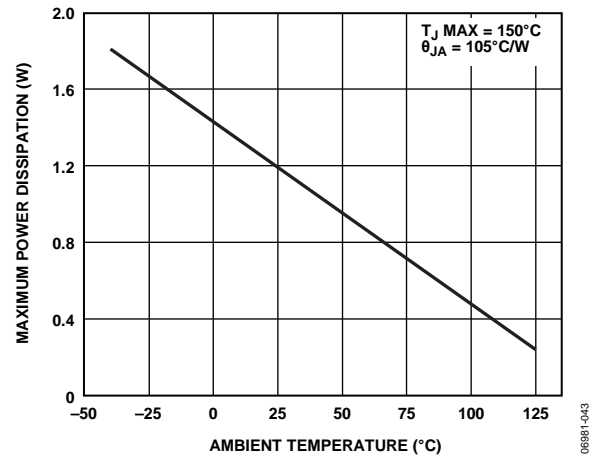

Figure 2. Maximum Power Dissipation vs. Ambient Temperature

ESD CAUTION



ESD (electrostatic discharge) sensitive device. Charged devices and circuit boards can discharge without detection. Although this product features patented or proprietary protection circuitry, damage may occur on devices subjected to high energy ESD. Therefore, proper ESD precautions should be taken to avoid performance degradation or loss of functionality.

PIN CONFIGURATION AND FUNCTION DESCRIPTIONS

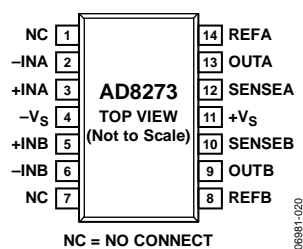

Figure 3. Pin Configuration

Table 4. Pin Function Descriptions

Pin No.	Mnemonic	Description
1, 7	NC	No Connect.
2	-INA	The 12 k Ω resistor connects to the negative terminal of Op Amp A.
3	+INA	The 12 k Ω resistor connects to the positive terminal of Op Amp A.
4	-Vs	Negative Supply.
5	+INB	The 12 k Ω resistor connects to the positive terminal of Op Amp B.
6	-INB	The 12 k Ω resistor connects to the negative terminal of Op Amp B.
8	REFB	The 6 k Ω resistor connects to the positive terminal of Op Amp B.
9	OUTB	Op Amp B Output.
10	SENSEB	The 6 k Ω resistor connects to the negative terminal of Op Amp B.
11	+Vs	Positive Supply.
12	SENSEA	The 6 k Ω resistor connects to the negative terminal of Op Amp A.
13	OUTA	Op Amp A Output.
14	REFA	The 6 k Ω resistor connects to the positive terminal of Op Amp A.

TYPICAL PERFORMANCE CHARACTERISTICS

$V_S = \pm 15\text{ V}$, $T_A = 25^\circ\text{C}$, $G = \frac{1}{2}$, difference amplifier configuration, unless otherwise noted.

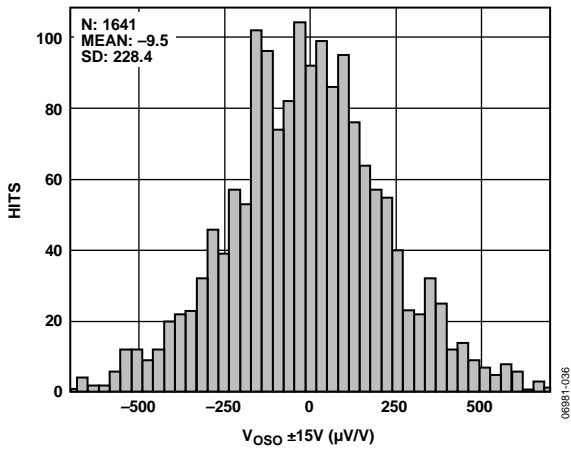

Figure 4. Typical Distribution of System Offset Voltage, $G = \frac{1}{2}$, Referred to Output

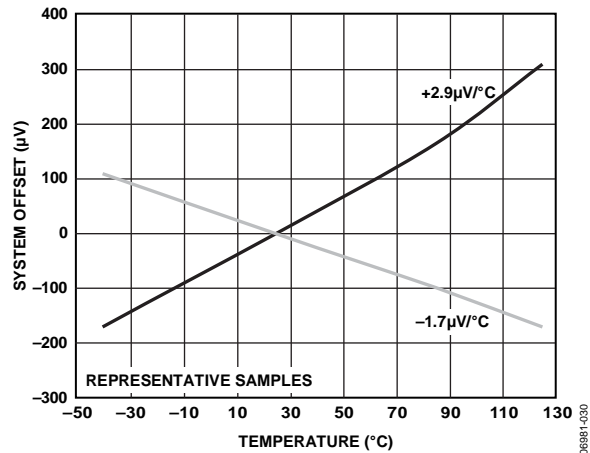

Figure 7. System Offset vs. Temperature, Normalized at 25°C , Referred to Output

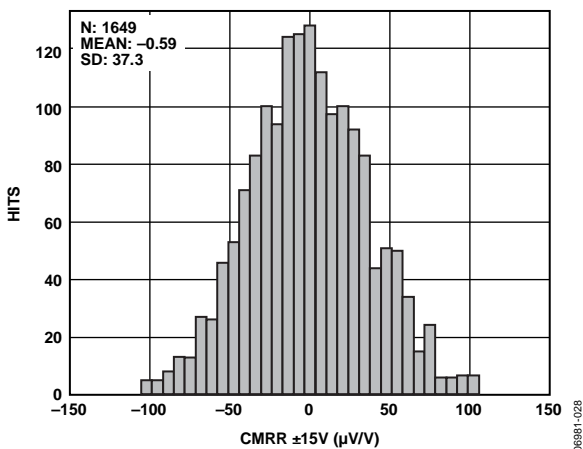

Figure 5. Typical Distribution of CMRR, $G = \frac{1}{2}$, Referred to Input

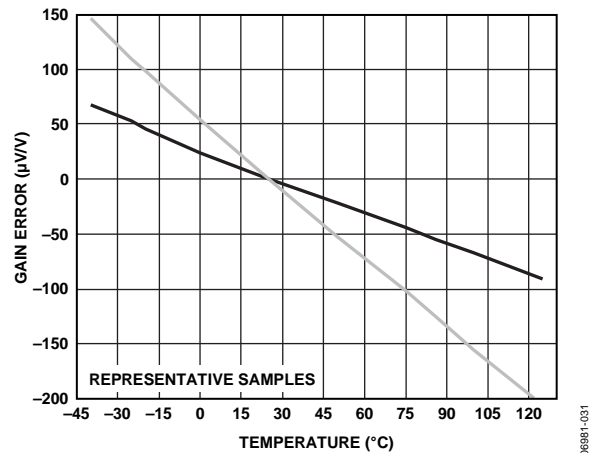

Figure 8. Gain Error vs. Temperature, Normalized at 25°C

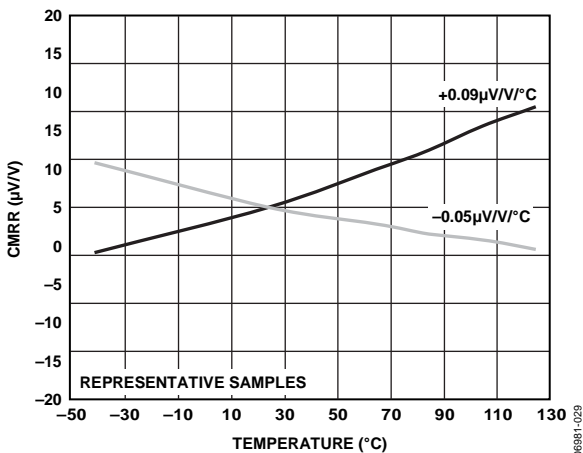

Figure 6. CMRR vs. Temperature, Normalized at 25°C

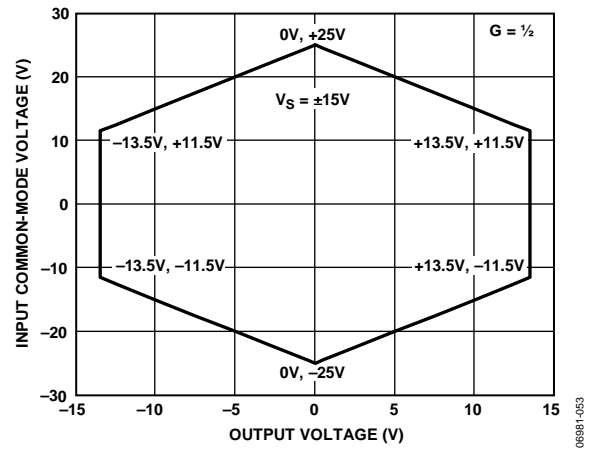

Figure 9. Input Common-Mode Voltage vs. Output Voltage, $\text{Gain} = \frac{1}{2}$, $\pm 15\text{ V}$ Supplies

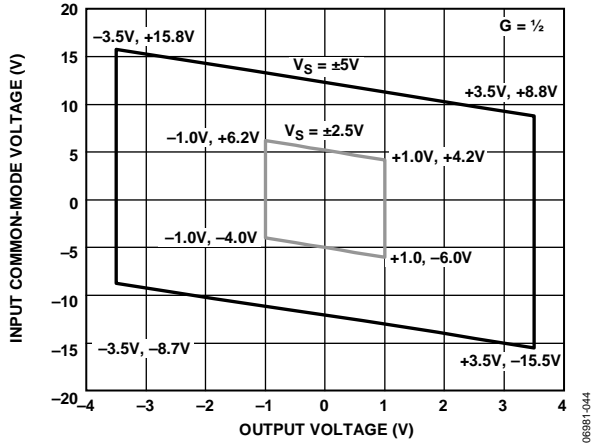

Figure 10. Input Common-Mode Voltage vs. Output Voltage, Gain = 1/2, ±5 V and ±2.5 V Supplies

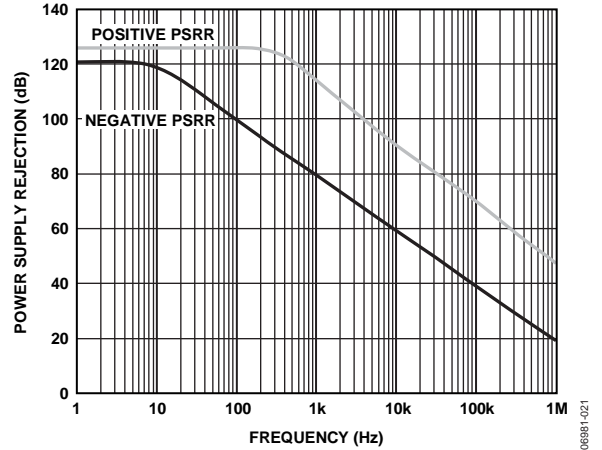

Figure 13. Power Supply Rejection vs. Frequency, $G = \frac{1}{2}$, Referred to Output

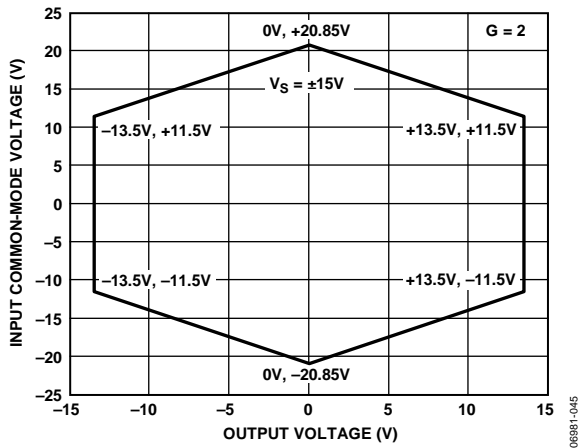

Figure 11. Input Common-Mode Voltage vs. Output Voltage, Gain = 2, ±15 V Supplies

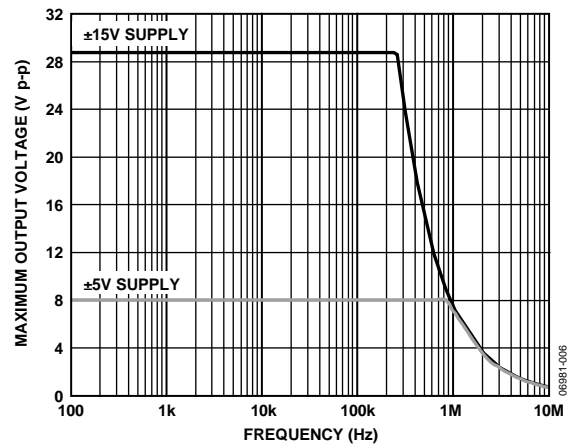

Figure 14. Maximum Output Voltage vs. Frequency

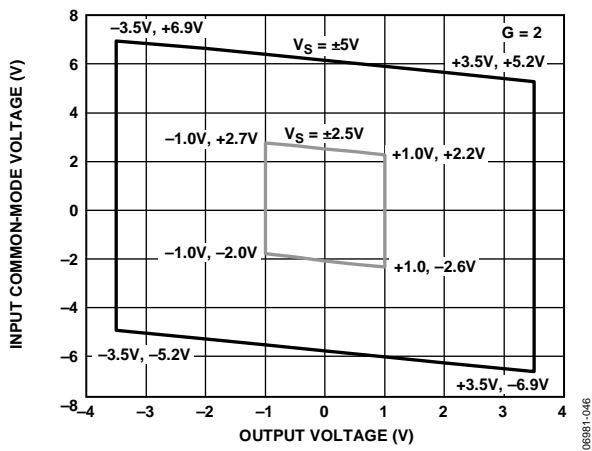

Figure 12. Input Common-Mode Voltage vs. Output Voltage, Gain = 2, ±5 V and ±2.5 V Supplies

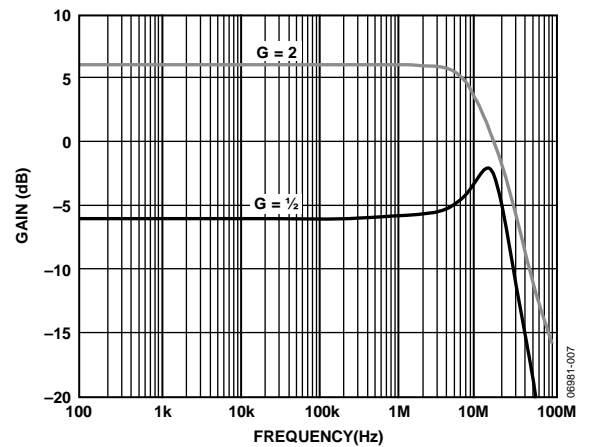

Figure 15. Gain vs. Frequency

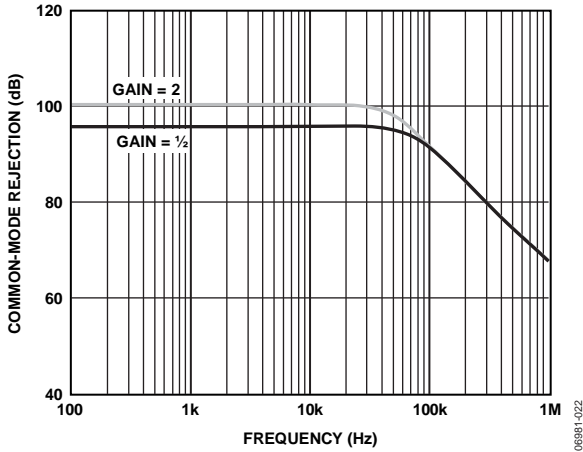

Figure 16. Common-Mode Rejection vs. Frequency, Referred to Input

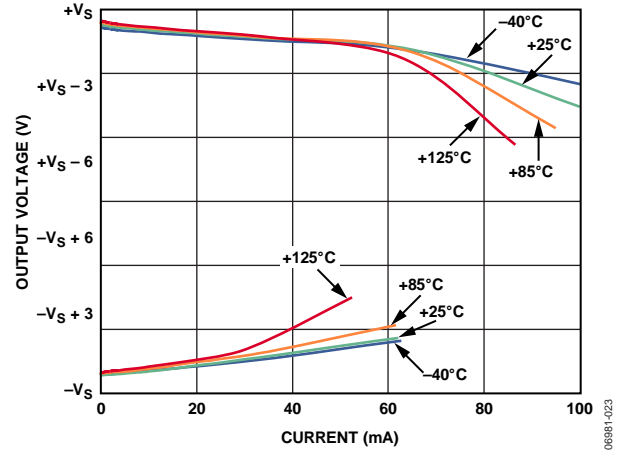

Figure 19. Output Voltage vs. I_{OUT}

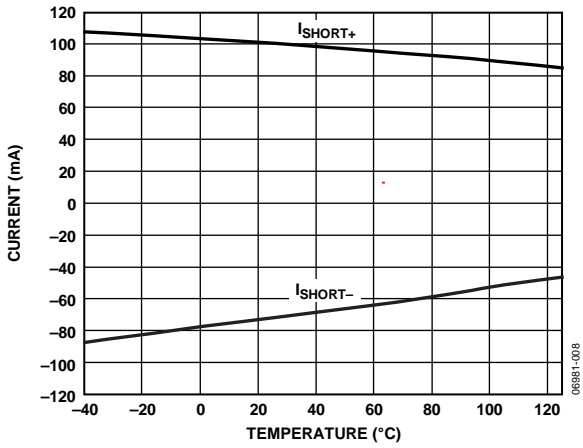

Figure 17. Short-Circuit Current vs. Temperature

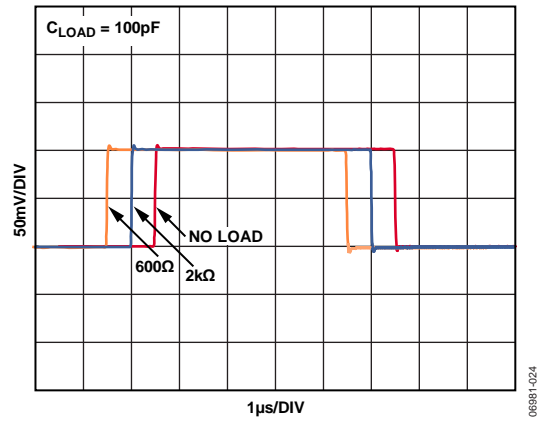

Figure 20. Small Signal Step Response, Gain = 2

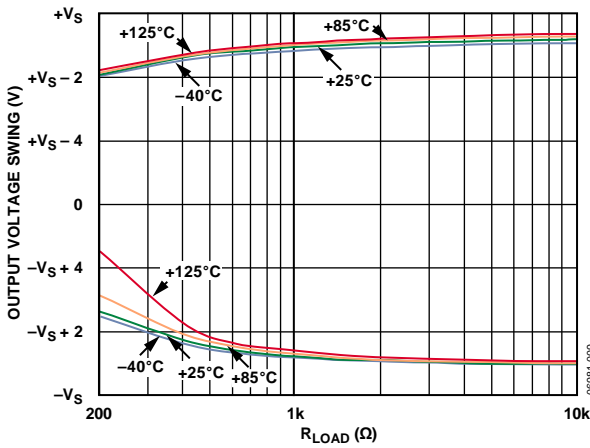

Figure 18. Output Voltage Swing vs. R_{LOAD} , $V_S = \pm 15 V$

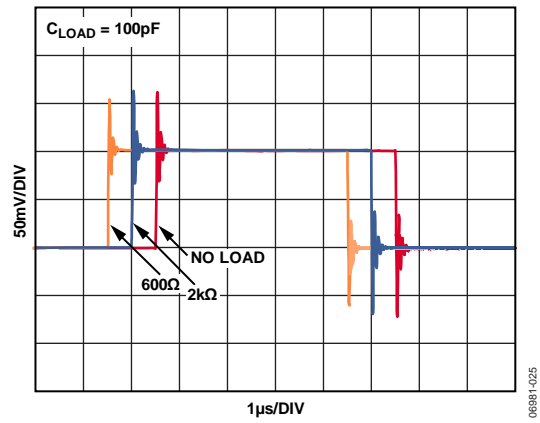

Figure 21. Small Signal Step Response, Gain = $\frac{1}{2}$

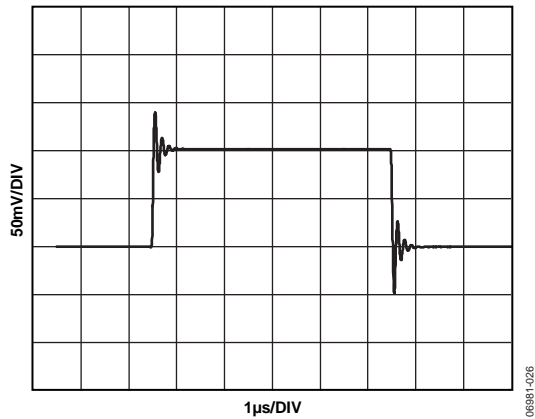

Figure 22. Small Signal Pulse Response with 500 pF Capacitor Load, Gain = 2

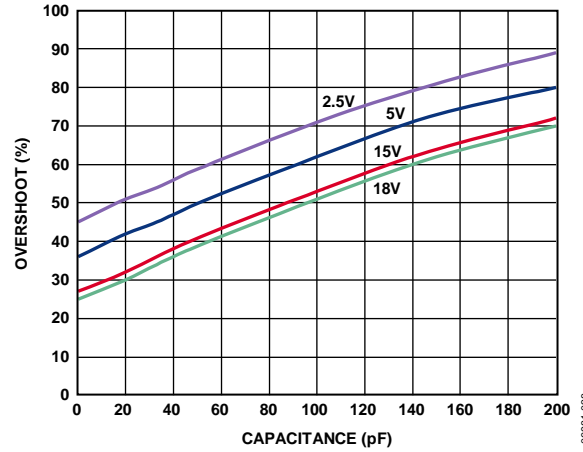

Figure 25. Small Signal Overshoot vs. Capacitive Load, $G = \frac{1}{2}$, 600Ω in Parallel with Capacitive Load

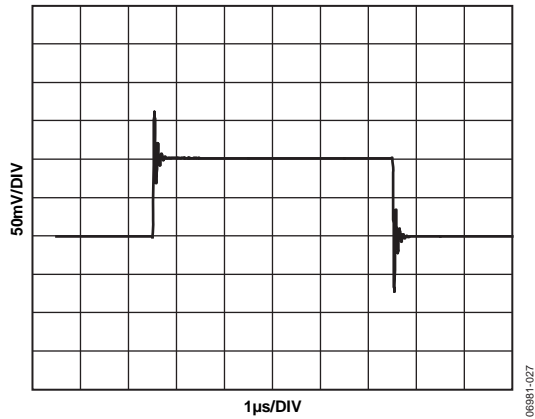

Figure 23. Small Signal Pulse Response for 100 pF Capacitive Load, Gain = $\frac{1}{2}$

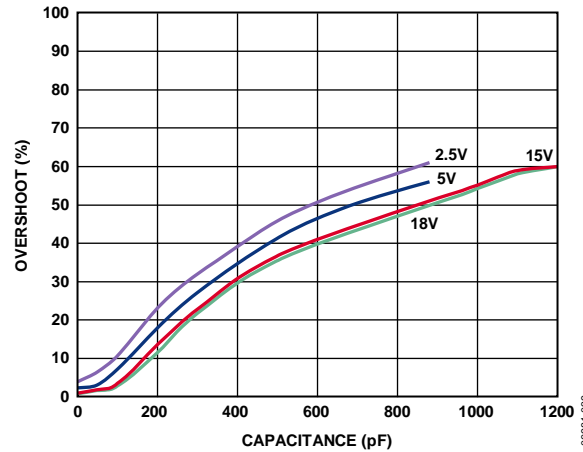

Figure 26. Small Signal Overshoot vs. Capacitive Load, $G = 2$, No Resistive Load

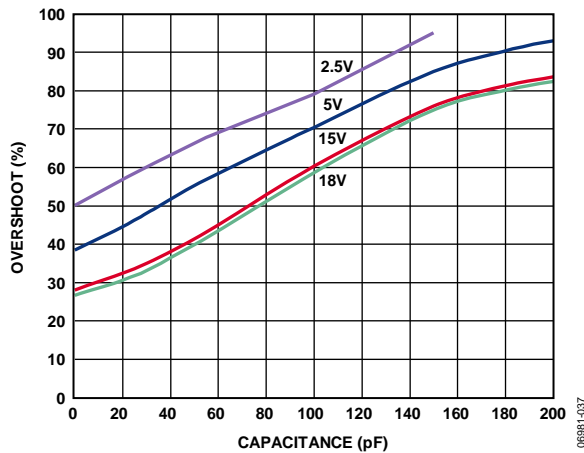

Figure 24. Small Signal Overshoot vs. Capacitive Load, $G = \frac{1}{2}$, No Resistive Load

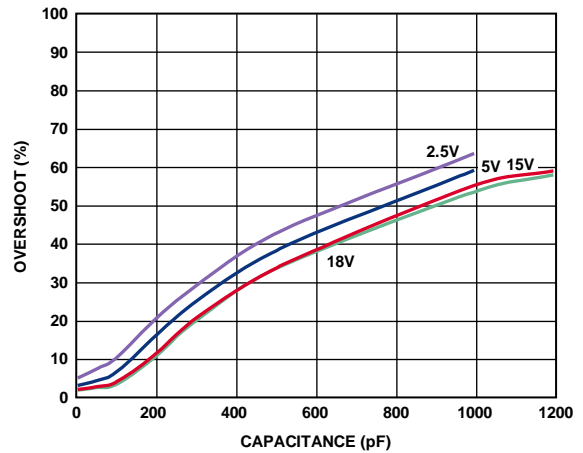

Figure 27. Small Signal Overshoot vs. Capacitive Load, $G = 2$, 600Ω in Parallel with Capacitive Load

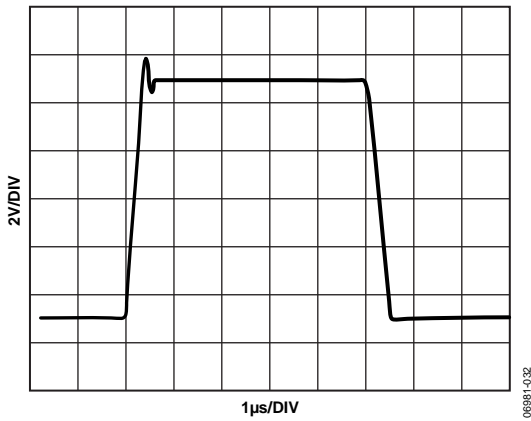

Figure 28. Large Signal Pulse Response, Gain = 1/2

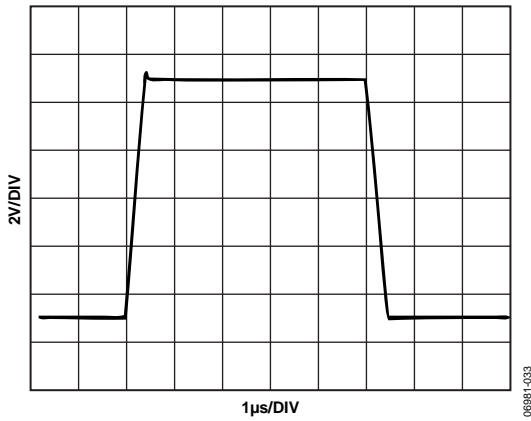

Figure 29. Large Signal Pulse Response, Gain = 2

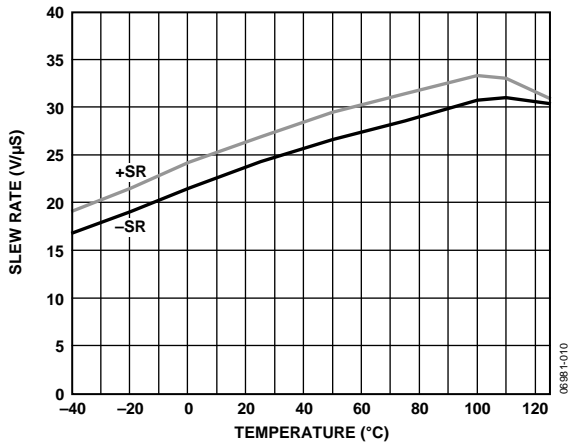

Figure 30. Slew Rate vs. Temperature

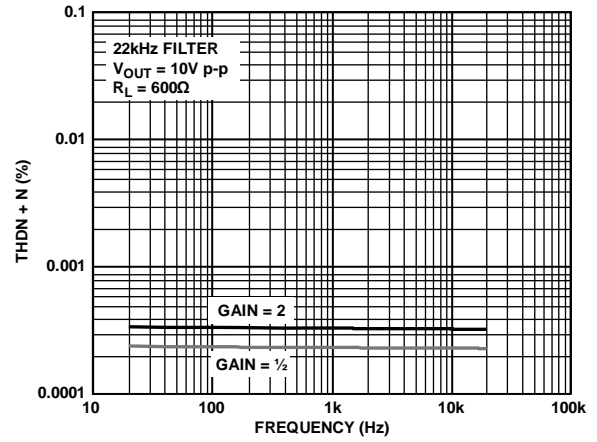

Figure 31. THD + N vs. Frequency, Filter = 22 kHz

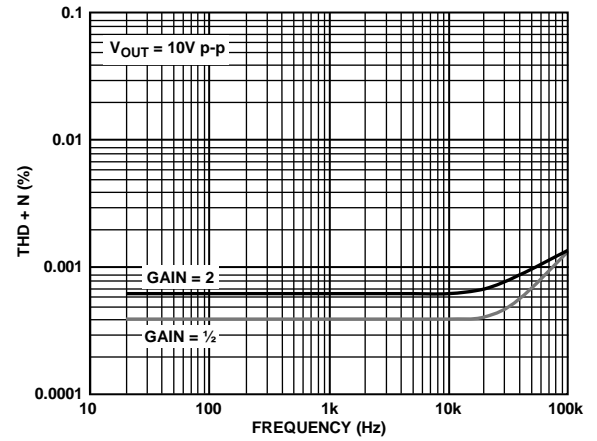

Figure 32. THD + N vs. Frequency, Filter = 120 kHz

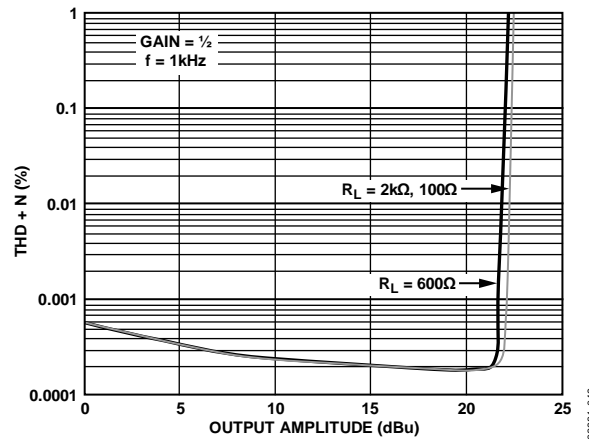

Figure 33. THD + N vs. Output Amplitude, G = 1/2

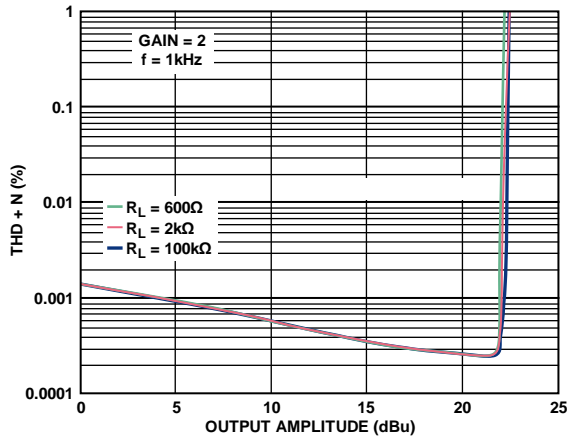

Figure 34. THD + N vs. Output Amplitude, G = 2

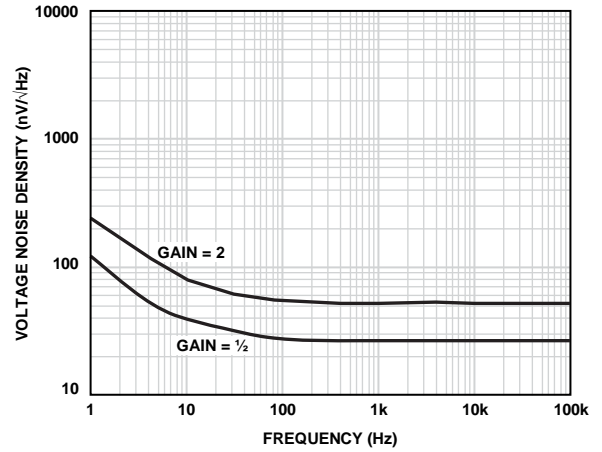

Figure 37. Voltage Noise Density vs. Frequency, Referred to Output

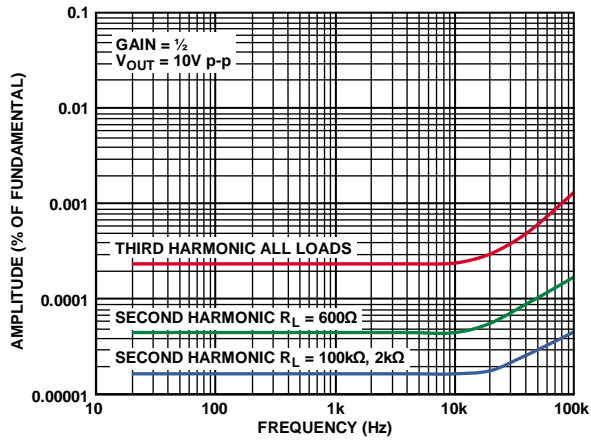

Figure 35. Harmonic Distortion Products vs. Frequency, G = 1/2

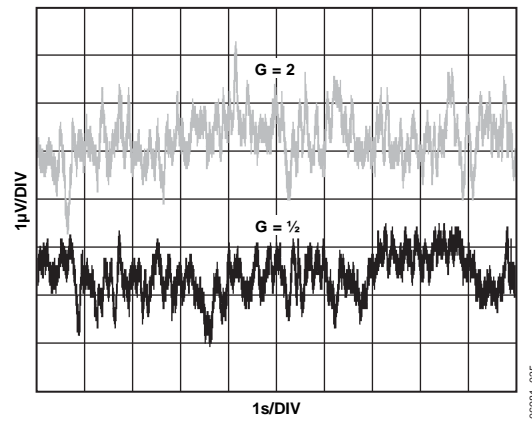

Figure 38. 0.1 Hz to 10 Hz Voltage Noise, RTO

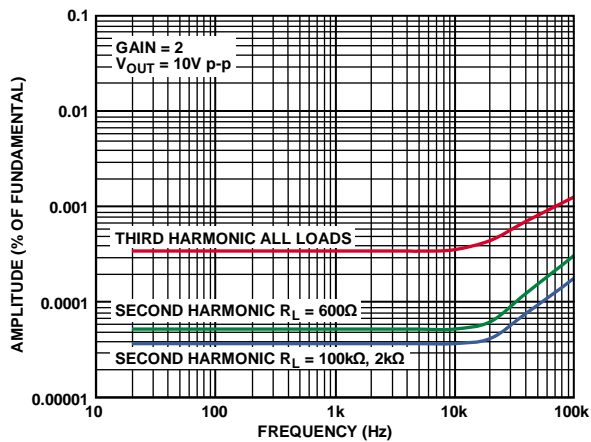

Figure 36. Harmonic Distortion Products vs. Frequency, G = 2

THEORY OF OPERATION

The AD8273 has two channels, each consisting of a high precision, low distortion op amp and four trimmed resistors. Although such a circuit can be built discretely, placing the resistors on the chip offers advantages to board designers that include better dc specifications, better ac specification, and lower production costs.

The resistors on the AD8273 are laser trimmed and tightly matched. Specifications that depend on the resistor matching, such as gain drift, common-mode rejection, and gain accuracy, are better than can be achieved with standard discrete resistors.

The positive and negative input terminals of the AD8273 op amp are not pinned out intentionally. Keeping these nodes internal means their capacitance is considerably lower than it would be in discrete designs. Lower capacitance at these nodes means better loop stability and improved common-mode rejection vs. frequency.

The internal resistors of the AD8273 lower production costs. One part rather than several is placed on the board, which improves both board build time and reliability.

CONFIGURATIONS

The AD8273 can be configured in several different ways; see Figure 39 to Figure 46. Because these configurations rely on the internal, matched resistors, these configurations have excellent gain accuracy and gain drift.

POWER SUPPLIES

Use a stable dc voltage to power the AD8273. Noise on the supply pins can adversely affect performance. Place a bypass capacitor of 0.1 μF between each supply pin and ground, as close to each pin as possible. Also, use a tantalum capacitor of 10 μF between each supply and ground. It can be farther away from the AD8273 and typically can be shared by other precision integrated circuits.

The AD8273 is specified at $\pm 15\text{ V}$, but it can be used with unbalanced supplies as well, for example, $-V_S = 0\text{ V}$, $+V_S = 20\text{ V}$. The difference between the two supplies must be kept below 36 V.

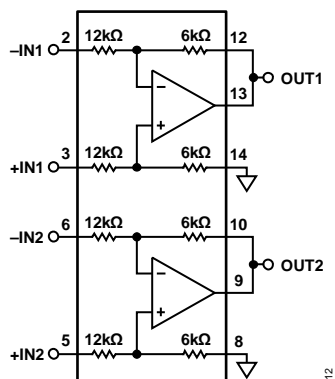

$$V_{OUT} = \frac{1}{2} (V_{IN+} - V_{IN-})$$

Figure 39. Difference Amplifier, $G = \frac{1}{2}$

06981-012

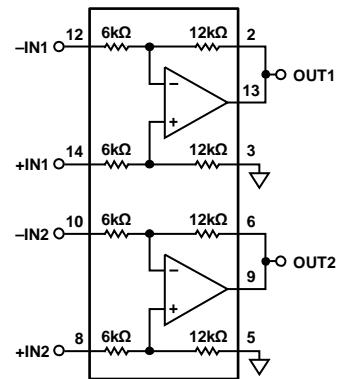

$$V_{OUT} = 2 (V_{IN+} - V_{IN-})$$

Figure 40. Difference Amplifier, $G = 2$

06981-016

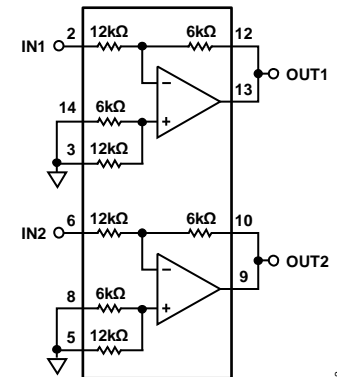

$$V_{OUT} = -\frac{1}{2} V_{IN}$$

Figure 41. Inverting Amplifier, $G = \frac{1}{2}$

06981-013

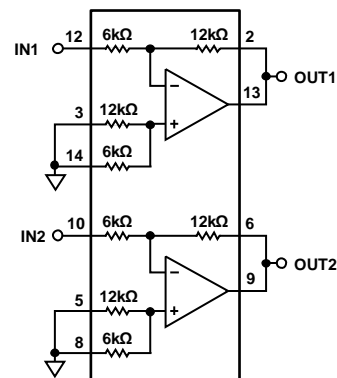

$$V_{OUT} = -2 V_{IN}$$

Figure 42. Inverting Amplifier, $G = 2$

06981-017

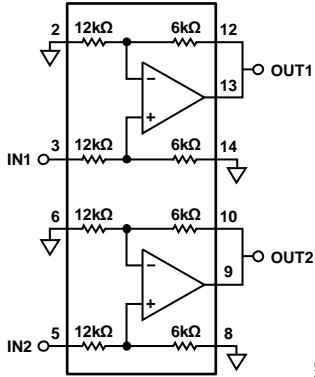

$V_{OUT} = \frac{1}{2} V_{IN}$

Figure 43. Noninverting Amplifier, $G = \frac{1}{2}$

06981-015

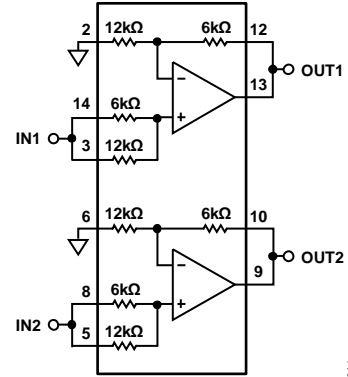

$V_{OUT} = 1\frac{1}{2} V_{IN}$

Figure 45. Noninverting Amplifier, $G = 1.5$

06981-014

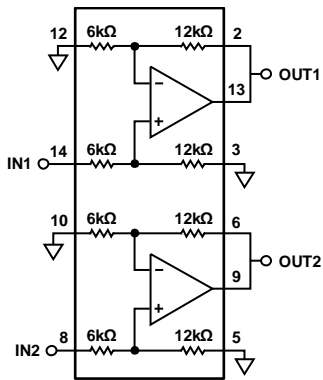

$V_{OUT} = 2 V_{IN}$

Figure 44. Noninverting Amplifier, $G = 2$

06981-019

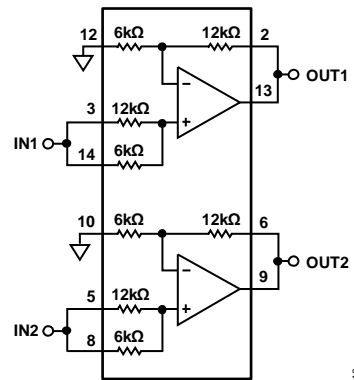

$V_{OUT} = 3 V_{IN}$

Figure 46. Noninverting Amplifier, $G = 3$

06981-018

OUTLINE DIMENSIONS

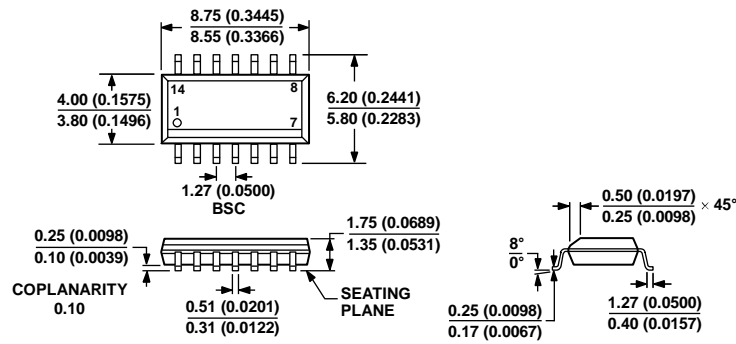

COMPLIANT TO JEDEC STANDARDS MS-012-AB
 CONTROLLING DIMENSIONS ARE IN MILLIMETERS; INCH DIMENSIONS
 (IN PARENTHESES) ARE ROUNDED-OFF MILLIMETER EQUIVALENTS FOR
 REFERENCE ONLY AND ARE NOT APPROPRIATE FOR USE IN DESIGN.

Figure 47. 14-Lead Standard Small Outline Package [SOIC_N]
 Narrow Body
 (R-14)
 Dimensions shown in millimeters and (inches)

060606-A

ORDERING GUIDE

Model ¹	Temperature Range	Package Description	Package Option
AD8273ARZ	-40°C to +85°C	14-Lead SOIC_N	R-14
AD8273ARZ-R7	-40°C to +85°C	14-Lead SOIC_N, 7" Tape and Reel	R-14
AD8273ARZ-RL	-40°C to +85°C	14-Lead SOIC_N, 13" Tape and Reel	R-14

¹ Z = RoHS Compliant Part.

NOTES

AD8273

NOTES

Looking for pricing, stock, or lifecycle information?

Click below to explore more details on WIN SOURCE:

 [View AD8273-EVALZ on WIN SOURCE](#)

 [Analog Devices Inc. Information](#)

Optimize Your Supply Chain with WIN SOURCE Solutions

-  Global Sourcing Solution
-  Obsolete Management
-  Cost Control Management
-  Shortage Management
-  Alternative Solution
-  Excess Inventory Management