



**THE DATASHEET OF  
EV-VND5T100AJ**



## Double channel high-side driver with analog current sense for 24 V automotive applications

Datasheet - production data



- Self limiting of fast thermal transients
- Protection against loss of ground and loss of  $V_{CC}$
- Thermal shutdown
- Electrostatic discharge protection

### Application

All types of resistive, inductive and capacitive loads

### Features

Max transient supply voltage	$V_{CC}$	58 V
Operating voltage range	$V_{CC}$	8 to 36 V
Typ on-state resistance (per ch.)	$R_{ON}$	100 m $\Omega$
Current limitation (typ)	$I_{LIM}$	22 A
Off-state supply current	$I_S$	2 $\mu A^{(1)}$

1. Typical value with all loads connected.

- General
  - Very low standby current
  - 3.0 V CMOS compatible input
  - Optimized electromagnetic emission
  - Very low electromagnetic susceptibility
  - Compliant with European directive 2002/95/EC
  - Fault reset standby pin (FR\_Stby)
- Diagnostic functions
  - Proportional load current sense
  - High current sense precision for wide range currents
  - Off-state open-load detection
  - Output short to  $V_{CC}$  detection
  - Overload and short to ground latch-off
  - Thermal shutdown latch-off
  - Very low current sense leakage
- Protection
  - Undervoltage shutdown
  - Overvoltage clamp
  - Load current limitation

### Description

The VND5T100AJ-E is a monolithic device made using STMicroelectronics® VIPower® technology, intended for driving resistive or inductive loads with one side connected to ground. Active  $V_{CC}$  pin voltage clamp protects the device against low energy spikes.

This device integrates an analog current sense which delivers a current proportional to the load current.

Fault conditions such as overload, overtemperature or short to  $V_{CC}$  are reported via the current sense pin.

Output current limitation protects the device in overload condition. The device latches off in case of overload or thermal shutdown.

The device is reset by a low level pass on the fault reset standby pin.

A permanent low level on the inputs and fault reset standby pin disables all outputs and sets the device in standby mode.

# Contents

<b>1</b>	<b>Block diagram and pin description</b>	<b>5</b>
<b>2</b>	<b>Electrical specifications</b>	<b>7</b>
2.1	Absolute maximum ratings	7
2.2	Thermal data	8
2.3	Electrical characteristics	9
2.4	Electrical characteristics curves	19
<b>3</b>	<b>Application information</b>	<b>21</b>
3.1	GND protection network against reverse battery	21
3.1.1	Solution 1: resistor in the ground line (RGND only)	21
3.1.2	Solution 2: diode (DGND) in the ground line	22
3.2	Load dump protection	22
3.3	MCU I/Os protection	22
3.4	Maximum demagnetization energy ( $V_{CC} = 24\text{ V}$ )	23
<b>4</b>	<b>Package and PCB thermal data</b>	<b>24</b>
4.1	PowerSSO-12 thermal data	24
<b>5</b>	<b>Package and packing information</b>	<b>27</b>
5.1	PowerSSO-12 mechanical data	27
5.2	Packing information	29
<b>6</b>	<b>Order code</b>	<b>30</b>
<b>7</b>	<b>Revision history</b>	<b>31</b>

## List of tables

Table 1.	Pin function . . . . .	5
Table 2.	Suggested connections for unused and not connected pins . . . . .	6
Table 3.	Absolute maximum ratings . . . . .	7
Table 4.	Thermal data . . . . .	8
Table 5.	Power section . . . . .	9
Table 6.	Switching ( $V_{CC} = 24\text{ V}$ ; $T_j = 25\text{ °C}$ ) . . . . .	9
Table 7.	Logic inputs . . . . .	9
Table 8.	Protections and diagnostics . . . . .	11
Table 9.	Current sense ( $8\text{ V} < V_{CC} < 36\text{ V}$ ) . . . . .	11
Table 10.	Open-load detection . . . . .	13
Table 11.	Truth table . . . . .	17
Table 12.	Electrical transient requirements (part 1) . . . . .	18
Table 13.	Electrical transient requirements (part 2) . . . . .	18
Table 14.	Electrical transient requirements (part 3) . . . . .	18
Table 15.	Thermal parameters . . . . .	26
Table 16.	PowerSSO-12 mechanical data . . . . .	28
Table 17.	Device summary . . . . .	30
Table 18.	Document revision history . . . . .	31

## List of figures

Figure 1.	Block diagram . . . . .	5
Figure 2.	Configuration diagram (top view) . . . . .	6
Figure 3.	Current and voltage conventions . . . . .	7
Figure 4.	$T_{\text{standby}}$ definition . . . . .	10
Figure 5.	$T_{\text{reset}}$ definition . . . . .	11
Figure 6.	Current sense delay characteristics . . . . .	13
Figure 7.	Open-load off-state delay timing . . . . .	13
Figure 8.	Switching characteristics . . . . .	14
Figure 9.	Output stuck to $V_{\text{CC}}$ detection delay time at FRSTBY activation . . . . .	14
Figure 10.	Delay response time between rising edge of output current and rising edge of current sense . . . . .	15
Figure 11.	Output voltage drop limitation . . . . .	15
Figure 12.	Device behavior in overload condition . . . . .	16
Figure 13.	Off-state output current . . . . .	19
Figure 14.	High level input current . . . . .	19
Figure 15.	Input clamp voltage . . . . .	19
Figure 16.	Input high level voltage . . . . .	19
Figure 17.	Input low level voltage . . . . .	19
Figure 18.	Input hysteresis voltage . . . . .	19
Figure 19.	On-state resistance vs $T_{\text{case}}$ . . . . .	20
Figure 20.	On-state resistance vs $V_{\text{CC}}$ . . . . .	20
Figure 21.	$I_{\text{LIMH}}$ vs $T_{\text{case}}$ . . . . .	20
Figure 22.	Turn-on voltage slope . . . . .	20
Figure 23.	Turn-off voltage slope . . . . .	20
Figure 24.	Application schematic . . . . .	21
Figure 25.	Maximum turn-off current versus inductance . . . . .	23
Figure 26.	PowerSSO-12 PC board . . . . .	24
Figure 27.	$R_{\text{thj-amb}}$ vs PCB copper area in open box free air condition (one channel ON) . . . . .	24
Figure 28.	PowerSSO-12 thermal impedance junction ambient single pulse (one channel ON) . . . . .	25
Figure 29.	Thermal fitting model of a double channel HSD in PowerSSO-12 . . . . .	25
Figure 30.	PowerSSO-12 package dimensions . . . . .	27
Figure 31.	PowerSSO-12 tube shipment (no suffix) . . . . .	29
Figure 32.	PowerSSO-12 tape and reel shipment (suffix "TR") . . . . .	29

# 1 Block diagram and pin description

Figure 1. Block diagram

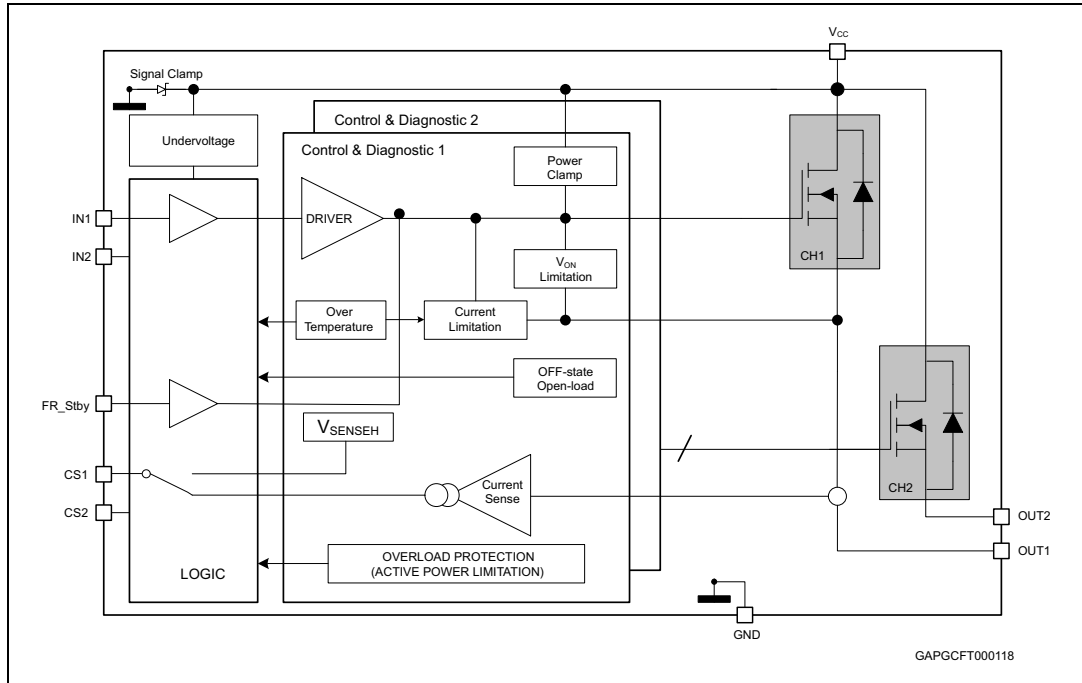


Table 1. Pin function

Name	Function
V <sub>CC</sub>	Battery connection
OUT <sub>n</sub>	Power output
GND	Ground connection
IN <sub>n</sub>	Voltage controlled input pin with hysteresis, CMOS compatible. Controls output switch state
CS <sub>n</sub>	Analog current sense pin, delivers a current proportional to the load current
FR_Stby	In case of latch-off for OT/overcurrent condition, a low pulse on the FR_Stby pin is needed to reset the channel. The device enters in standby mode if all inputs and the FR_Stby pin are low.

Figure 2. Configuration diagram (top view)

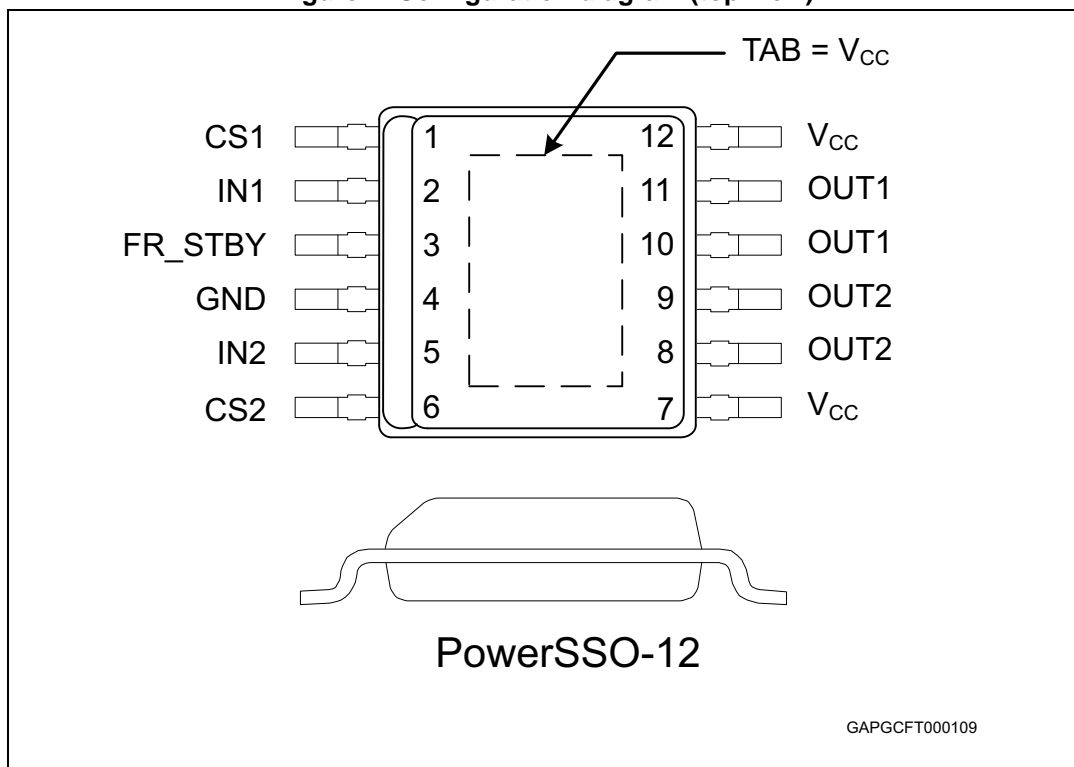
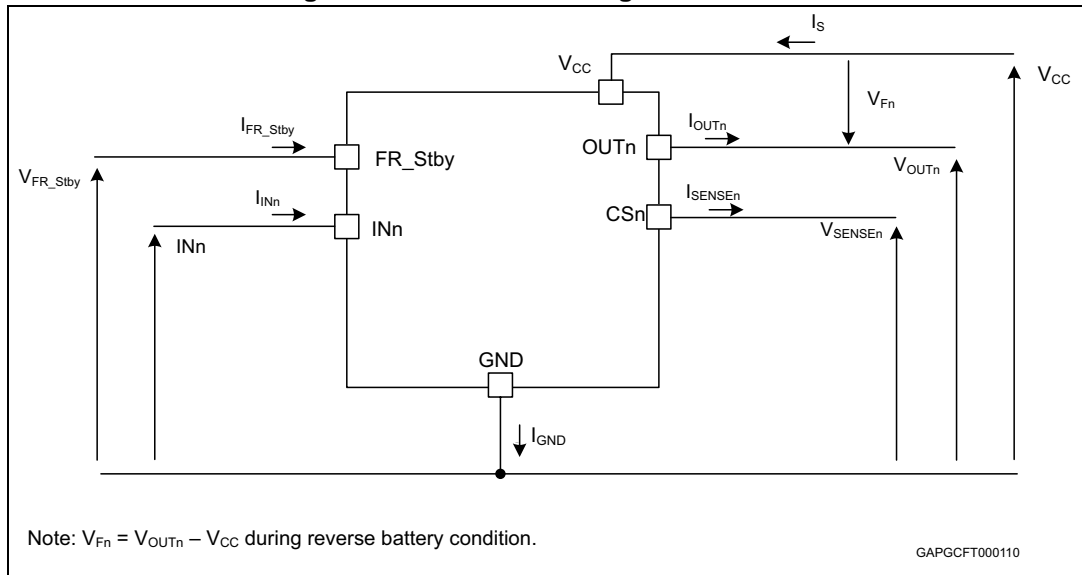


Table 2. Suggested connections for unused and not connected pins

Connection / pin	Current sense	N.C.	Output	Input	FR_Stby
Floating	Not allowed	X	X	X	X
To ground	Through 10 kΩ resistor	X	Not allowed	Through 10 kΩ resistor	Through 10 kΩ resistor

## 2 Electrical specifications

Figure 3. Current and voltage conventions



### 2.1 Absolute maximum ratings

Stressing the device above the ratings listed in [Table 3](#) may cause permanent damage to the device. These are stress ratings only and operation of the device at these or any other conditions above those indicated in the operating sections of this specification is not implied. Exposure to the conditions reported in this section for extended periods may affect device reliability.

Table 3. Absolute maximum ratings

Symbol	Parameter	Value	Unit
$V_{CC}$	DC supply voltage	58	V
$-V_{CC}$	Reverse DC supply voltage	0.3	V
$-I_{GND}$	DC reverse ground pin current	200	mA
$I_{OUT}$	DC output current	Internally limited	A
$-I_{OUT}$	Reverse DC output current	20	A
$I_{IN}$	DC input current	-1 to 10	mA
$I_{FR\_Stby}$	Fault reset standby DC input current	-1 to 1.5	mA
$-I_{CSENSE}$	DC reverse CS pin current	200	mA
$V_{CSENSE}$	Current sense maximum voltage	$V_{CC} - 58$ to $+V_{CC}$	V
$E_{MAX}$	Maximum switching energy ( $L = 1.9$ mH; $V_{bat} = 32$ V; $T_{jstart} = 150$ °C; $I_{OUT} = I_{limL}$ (Typ))	70	mJ

Table 3. Absolute maximum ratings (continued)

Symbol	Parameter	Value	Unit
V <sub>ESD</sub>	Electrostatic discharge (Human Body Model: R = 1.5 kΩ; C = 100 pF)		
	– INPUT	4000	V
	– CURRENT SENSE	2000	V
	– FR_STBY	4000	V
	– OUTPUT	5000	V
	– V <sub>CC</sub>	5000	V
V <sub>ESD</sub>	Charge device model (CDM-AEC-Q100-011)	750	V
T <sub>j</sub>	Junction operating temperature	-40 to 150	°C
T <sub>stg</sub>	Storage temperature	-55 to 150	°C
L <sub>Smax</sub>	Maximum stray inductance in short circuit R <sub>L</sub> = 300 mΩ, V <sub>bat</sub> = 32 V, T <sub>jstart</sub> = 150 °C, I <sub>OUT</sub> = I <sub>limHmax</sub>	40	μH

## 2.2 Thermal data

Table 4. Thermal data

Symbol	Parameter	Maximum value	Unit
R <sub>thj-case</sub>	Thermal resistance junction-case (with one channel ON)	6	°C/W
R <sub>thj-amb</sub>	Thermal resistance junction-ambient	See <a href="#">Figure 27</a>	°C/W

## 2.3 Electrical characteristics

$8\text{ V} < V_{CC} < 36\text{ V}$ ;  $-40\text{ °C} < T_j < 150\text{ °C}$ , unless otherwise specified.

**Table 5. Power section**

Symbol	Parameter	Test conditions	Min.	Typ.	Max.	Unit
$V_{CC}$	Operating supply voltage		8	24	36	V
$V_{USD}$	Undervoltage shutdown			3.5	5	V
$V_{USDhyst}$	Undervoltage shutdown hysteresis			0.5		V
$R_{ON}$	On-state resistance <sup>(1)</sup>	$I_{OUT} = 1.5\text{ A}$ ; $T_j = 25\text{ °C}$		100		mΩ
		$I_{OUT} = 1.5\text{ A}$ ; $T_j = 150\text{ °C}$			200	
$V_{clamp}$	Clamp voltage	$I_S = 20\text{ mA}$	58	64	70	V
$I_S$	Supply current	Off-state: $V_{CC} = 24\text{ V}$ ; $T_j = 25\text{ °C}$ ; $V_{IN} = V_{OUT} = V_{SENSE} = 0\text{ V}$		2 <sup>(2)</sup>	5 <sup>(2)</sup>	μA
		On-state: $V_{CC} = 24\text{ V}$ ; $V_{IN} = 5\text{ V}$ ; $I_{OUT} = 0\text{ A}$		4.2	6	mA
$I_{L(off)}$	Off-state output current	$V_{IN} = V_{OUT} = 0\text{ V}$ ; $V_{CC} = 24\text{ V}$ ; $T_j = 25\text{ °C}$	0	0.01	3	μA
		$V_{IN} = V_{OUT} = 0\text{ V}$ ; $V_{CC} = 24\text{ V}$ ; $T_j = 125\text{ °C}$	0		5	
$V_F$	Output - $V_{CC}$ diode voltage	$-I_{OUT} = 1.5\text{ A}$ ; $T_j = 150\text{ °C}$			0.7	V

1. For each channel.
2. PowerMos leakage included

**Table 6. Switching ( $V_{CC} = 24\text{ V}$ ;  $T_j = 25\text{ °C}$ )**

Symbol	Parameter	Test conditions	Min.	Typ.	Max.	Unit
$t_{d(on)}$	Turn-on delay time	$R_L = 16\text{ Ω}$		27		μs
$t_{d(off)}$	Turn-off delay time	$R_L = 16\text{ Ω}$		38		μs
$dV_{OUT}/dt_{(on)}$	Turn-on voltage slope	$R_L = 16\text{ Ω}$		1		V/μs
$dV_{OUT}/dt_{(off)}$	Turn-off voltage slope	$R_L = 16\text{ Ω}$		0.65		V/μs
$W_{ON}$	Switching energy losses during $t_{won}$	$R_L = 16\text{ Ω}$		0.23		mJ
$W_{OFF}$	Switching energy losses during $t_{woff}$	$R_L = 16\text{ Ω}$		0.26		mJ

**Table 7. Logic inputs**

Symbol	Parameter	Test conditions	Min.	Typ.	Max.	Unit
$V_{IL}$	Input low level voltage				0.9	V
$I_{IL}$	Low level input current	$V_{IN} = 0.9\text{ V}$	1			μA
$V_{IH}$	Input high level voltage		2.1			V

Table 7. Logic inputs (continued)

Symbol	Parameter	Test conditions	Min.	Typ.	Max.	Unit
$I_{IH}$	High level input current	$V_{IN} = 2.1\text{ V}$			10	$\mu\text{A}$
$V_{I(hyst)}$	Input hysteresis voltage		0.25			V
$V_{ICL}$	Input clamp voltage	$I_{IN} = 1\text{ mA}$	5.5		7	V
		$I_{IN} = -1\text{ mA}$		-0.7		V
$V_{FR\_Stby\_L}$	Fault_reset_standby low level voltage				0.9	V
$I_{FR\_Stby\_L}$	Low level fault_reset_standby current	$V_{FR\_Stby} = 0.9\text{ V}$	1			$\mu\text{A}$
$V_{FR\_Stby\_H}$	Fault_reset_standby high level voltage		2.1			V
$I_{FR\_Stby\_H}$	High level fault_reset_standby current	$V_{FR\_Stby} = 2.1\text{ V}$			10	$\mu\text{A}$
$V_{FR\_Stby(hyst)}$	Fault_reset_standby hysteresis voltage		0.25			V
$V_{FR\_Stby\_CL}$	Fault_reset_standby clamp voltage	$I_{FR\_Stby} = 15\text{ mA}$ ( $t < 10\text{ ms}$ )	11		15	V
		$I_{FR\_Stby} = -1\text{ mA}$		-0.7		V
$t_{reset}$	Overload latch-off reset time	See <a href="#">Figure 4</a>	2		24	$\mu\text{s}$
$t_{stby}$	Standby delay	See <a href="#">Figure 5</a>	120		1200	$\mu\text{s}$

Figure 4.  $T_{standby}$  definition

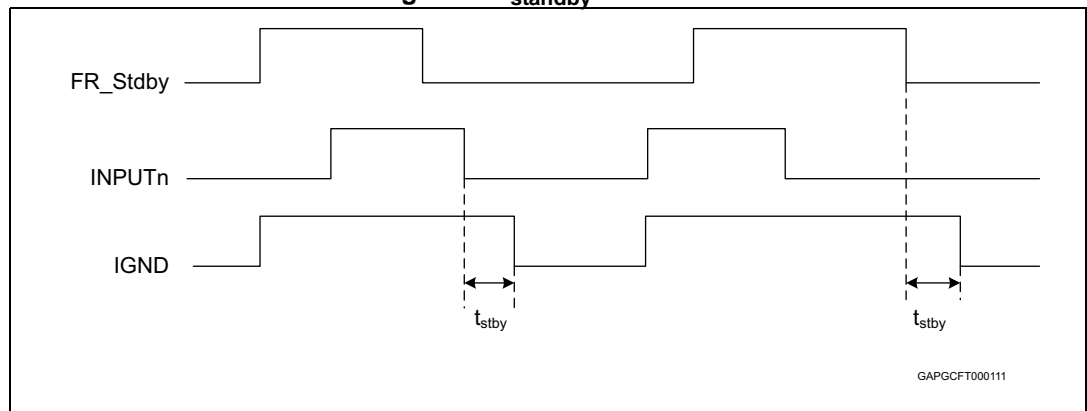


Figure 5.  $T_{reset}$  definition

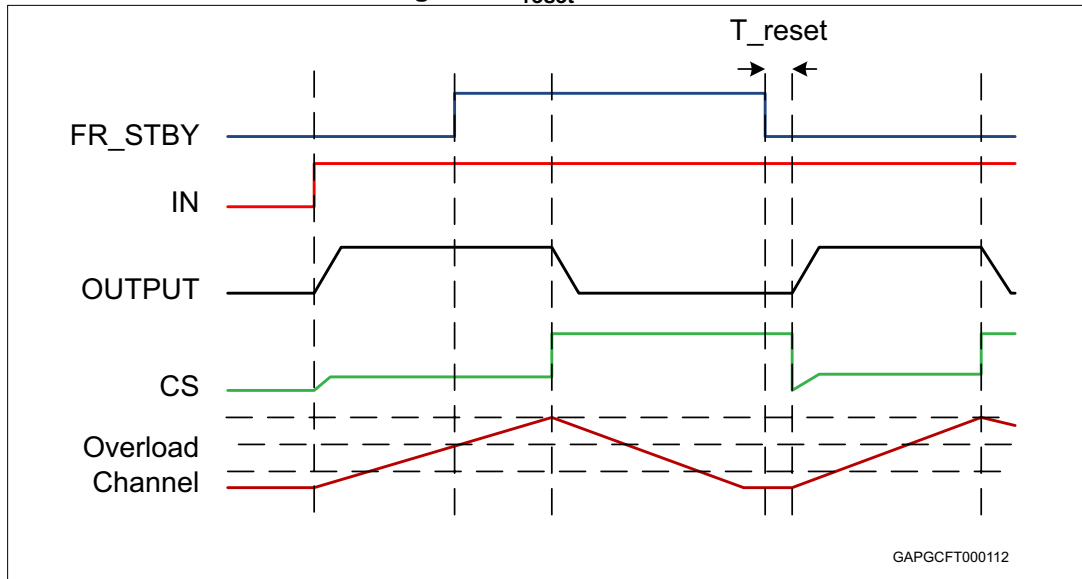


Table 8. Protections and diagnostics

Symbol	Parameter	Test conditions	Min.	Typ.	Max.	Unit
$I_{limH}$	DC short circuit current	$V_{CC} = 24\text{ V}$	16	22	30	A
		$5\text{ V} < V_{CC} < 36\text{ V}$			30	A
$I_{limL}$	Short circuit current during thermal cycling	$V_{CC} = 24\text{ V};$ $T_R < T_j < T_{TSD}$		6		A
$T_{TSD}$	Shutdown temperature		150	175	200	$^{\circ}\text{C}$
$T_R$	Reset temperature		$T_{RS} + 1$	$T_{RS} + 5$		$^{\circ}\text{C}$
$T_{RS}$	Thermal reset of status		135			$^{\circ}\text{C}$
$T_{HYST}$	Thermal hysteresis ( $T_{TSD} - T_R$ )			7		$^{\circ}\text{C}$
$V_{DEMAG}$	Turn-off output voltage clamp	$I_{OUT} = 1.5\text{ A}; V_{IN} = 0;$ $L = 6\text{ mH}$	$V_{CC} - 58$	$V_{CC} - 64$	$V_{CC} - 70$	V
$V_{ON}$	Output voltage drop limitation	$I_{OUT} = 50\text{ mA};$ $T_j = -40\text{ }^{\circ}\text{C}$ to $150\text{ }^{\circ}\text{C}$		25		mV

Table 9. Current sense ( $8\text{ V} < V_{CC} < 36\text{ V}$ )

Symbol	Parameter	Test conditions	Min.	Typ.	Max.	Unit
$K_1$	$I_{OUT}/I_{SENSE}$	$I_{OUT} = 350\text{ mA}; V_{SENSE} = 1\text{ V};$ $T_j = -40\text{ }^{\circ}\text{C}$ to $150\text{ }^{\circ}\text{C}$	930	1547	2185	
		$T_j = 25\text{ }^{\circ}\text{C}$ to $150\text{ }^{\circ}\text{C}$	1050	1547	2020	
$dK_1/K_1^{(1)}$	Current sense ratio drift	$I_{OUT} = 350\text{ mA}; V_{SENSE} = 1\text{ V};$ $T_j = -40\text{ }^{\circ}\text{C}$ to $150\text{ }^{\circ}\text{C}$	-15		15	%

Table 9. Current sense (8 V < V<sub>CC</sub> < 36 V) (continued)

Symbol	Parameter	Test conditions	Min.	Typ.	Max.	Unit
K <sub>2</sub>	I <sub>OUT</sub> /I <sub>SENSE</sub>	I <sub>OUT</sub> = 0.8 A; V <sub>SENSE</sub> = 2 V; T <sub>j</sub> = -40 °C to 150 °C T <sub>j</sub> = 25 °C to 150 °C	1225 1310	1528 1528	1835 1745	
dK <sub>2</sub> /K <sub>2</sub> <sup>(1)</sup>	Current sense ratio drift	I <sub>OUT</sub> = 0.8 A; V <sub>SENSE</sub> = 2 V; T <sub>j</sub> = -40 °C to 150 °C	-12		12	%
K <sub>3</sub>	I <sub>OUT</sub> /I <sub>SENSE</sub>	I <sub>OUT</sub> = 1.5 A; V <sub>SENSE</sub> = 2 V; T <sub>j</sub> = -40 °C to 150 °C T <sub>j</sub> = 25 °C to 150 °C	1340 1405	1525 1525	1715 1655	
dK <sub>3</sub> /K <sub>3</sub> <sup>(1)</sup>	Current sense ratio drift	I <sub>OUT</sub> = 1.5 A; V <sub>SENSE</sub> = 2 V; T <sub>j</sub> = -40 °C to 150 °C	-8		8	%
K <sub>4</sub>	I <sub>OUT</sub> /I <sub>SENSE</sub>	I <sub>OUT</sub> = 6 A; V <sub>SENSE</sub> = 4 V; T <sub>j</sub> = -40 °C to 150 °C T <sub>j</sub> = 25 °C to 150 °C	1450 1475	1522 1522	1600 1560	
dK <sub>4</sub> /K <sub>4</sub> <sup>(1)</sup>	Current sense ratio drift	I <sub>OUT</sub> = 6 A; V <sub>SENSE</sub> = 4 V; T <sub>j</sub> = -40 °C to 150 °C	-5		5	%
I <sub>SENSE0</sub>	Analog sense leakage current	I <sub>OUT</sub> = 0 A; V <sub>SENSE</sub> = 0 V; V <sub>IN</sub> = 0 V; T <sub>j</sub> = -40 °C to 150 °C	0		1	μA
		I <sub>OUT</sub> = 0 A; V <sub>SENSE</sub> = 0 V; V <sub>IN</sub> = 5 V; T <sub>j</sub> = -40 °C to 150 °C	0		2	μA
V <sub>SENSE</sub>	Max analog sense output voltage	I <sub>OUT</sub> = 6 A; R <sub>SENSE</sub> = 3.9 kΩ	5			V
V <sub>SENSEH</sub>	Analog sense output voltage in fault condition <sup>(2)</sup>	V <sub>CC</sub> = 24 V; R <sub>SENSE</sub> = 3.9 kΩ	7.5	8.5	9.5	V
I <sub>SENSEH</sub>	Analog sense output current in fault condition <sup>(2)</sup>	V <sub>CC</sub> = 24 V; V <sub>SENSE</sub> = 5 V	4.9	9	12	mA
t <sub>DSENSE2H</sub>	Delay response time from rising edge of INPUT pin	V <sub>SENSE</sub> < 4 V; 0.07 A < I <sub>OUT</sub> < 6 A; I <sub>SENSE</sub> = 90 % of I <sub>SENSE max</sub> (see <a href="#">Figure 6</a> )		100	200	μs
Δt <sub>DSENSE2H</sub>	Delay response time between rising edge of output current and rising edge of current sense	V <sub>SENSE</sub> < 4 V; I <sub>SENSE</sub> = 90 % of I <sub>SENSEMAX</sub> , I <sub>OUT</sub> = 90 % of I <sub>OUTMAX</sub> I <sub>OUTMAX</sub> = 1.5 A (see <a href="#">Figure 11</a> )			150	μs
t <sub>DSENSE2L</sub>	Delay response time from falling edge of INPUT pin	V <sub>SENSE</sub> < 4 V, 0.07 A < I <sub>OUT</sub> < 6 A; I <sub>SENSE</sub> = 10 % of I <sub>SENSE max</sub> (see <a href="#">Figure 6</a> )		5	20	μs

1. Parameter guaranteed by design; it is not tested.

2. Fault condition includes: power limitation, overtemperature and open-load in OFF-state condition.

Table 10. Open-load detection

Symbol	Parameter	Test conditions	Min.	Typ.	Max.	Unit
$V_{OL}$	Open-load off-state voltage detection threshold	$V_{IN} = 0\text{ V}; 8\text{ V} < V_{CC} < 36\text{ V}; F_{R\_STBY} = 5\text{ V}$	2		4	V
$t_{DSTKON}$	Output short circuit to $V_{CC}$ detection delay at turn off	See <a href="#">Figure 6</a> ; $F_{R\_STBY} = 5\text{ V}$	180		1800	$\mu\text{s}$
$t_{DFRSTK\_ON}$	Output short circuit to $V_{CC}$ detection delay at FRSTBY activation	See <a href="#">Figure 9</a> ; Input <sub>1,2</sub> = low			50	$\mu\text{s}$
$I_{L(off2)}$	Off-state output current at $V_{OUT} = 4\text{ V}$	$V_{IN} = 0\text{ V}; V_{SENSE} = 0\text{ V}; V_{OUT}$ rising from 0 V to 4 V; $F_{R\_STBY} = 5\text{ V}$	-120		0	$\mu\text{A}$
$t_{d\_vol}$	Delay response from output rising edge to $V_{SENSE}$ rising edge in open-load	$V_{OUT} = 4\text{ V}; V_{IN} = 0\text{ V}; V_{SENSE} = 90\% \text{ of } V_{SENSEH}; R_{SENSE} = 3.9\text{ k}\Omega; F_{R\_STBY} = 5\text{ V}$			20	$\mu\text{s}$

Figure 6. Current sense delay characteristics

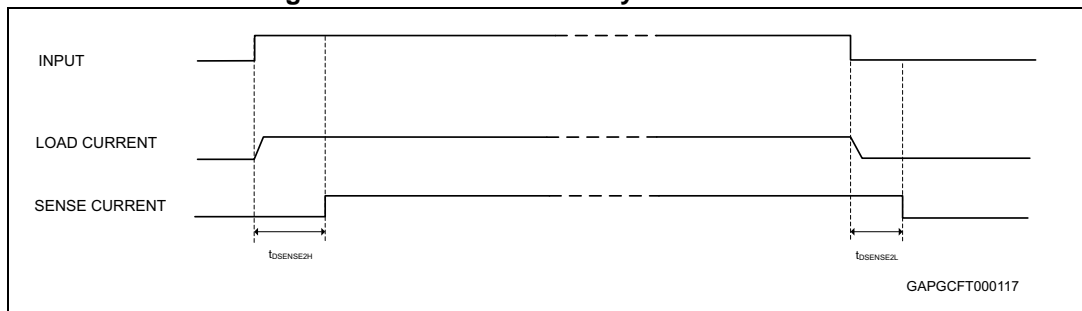


Figure 7. Open-load off-state delay timing

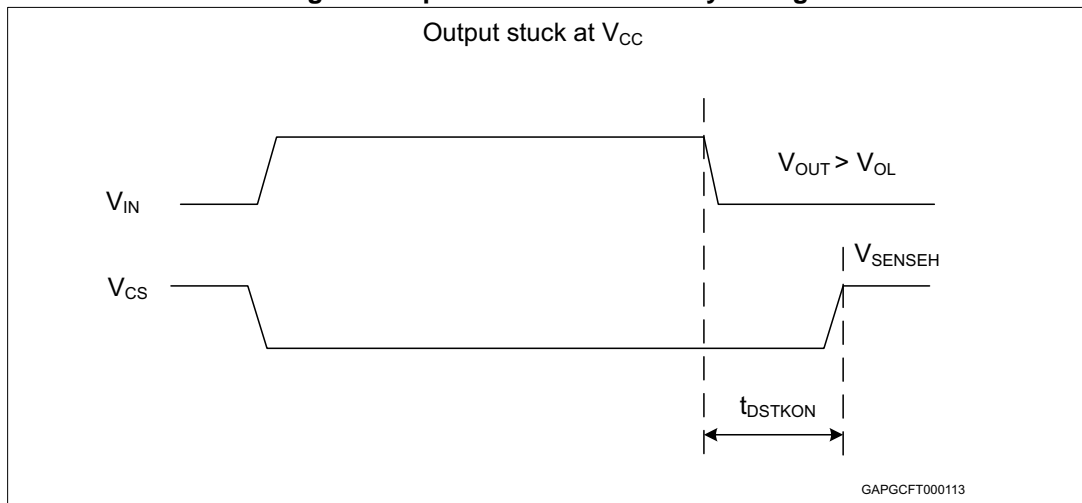


Figure 8. Switching characteristics

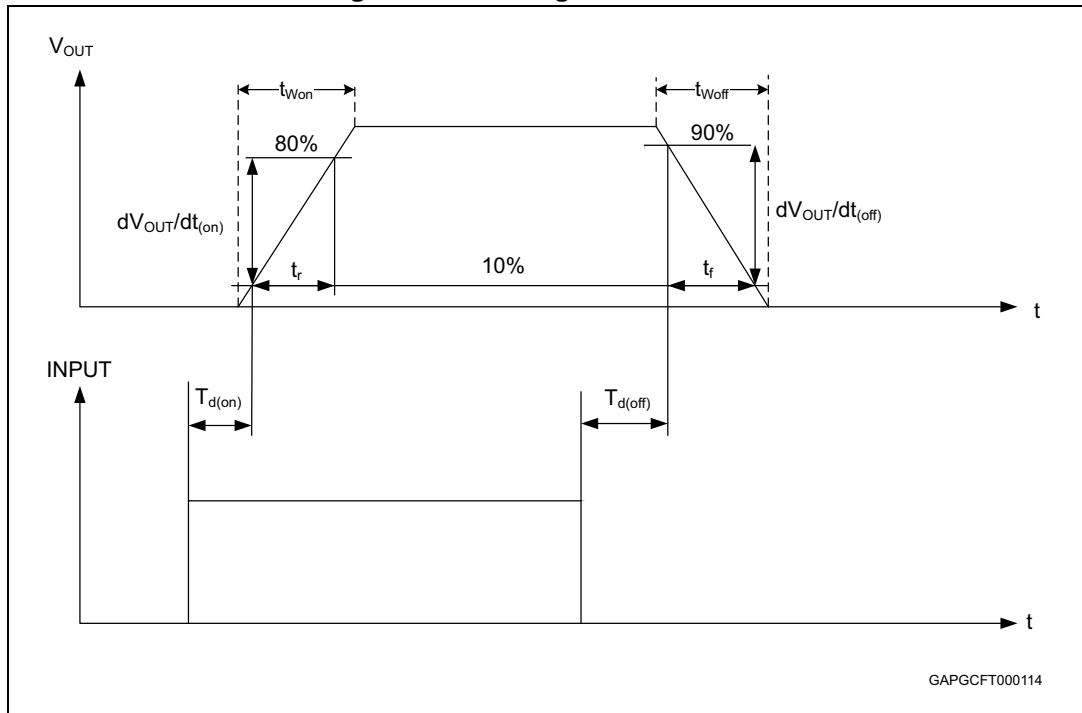


Figure 9. Output stuck to  $V_{CC}$  detection delay time at FRSTBY activation

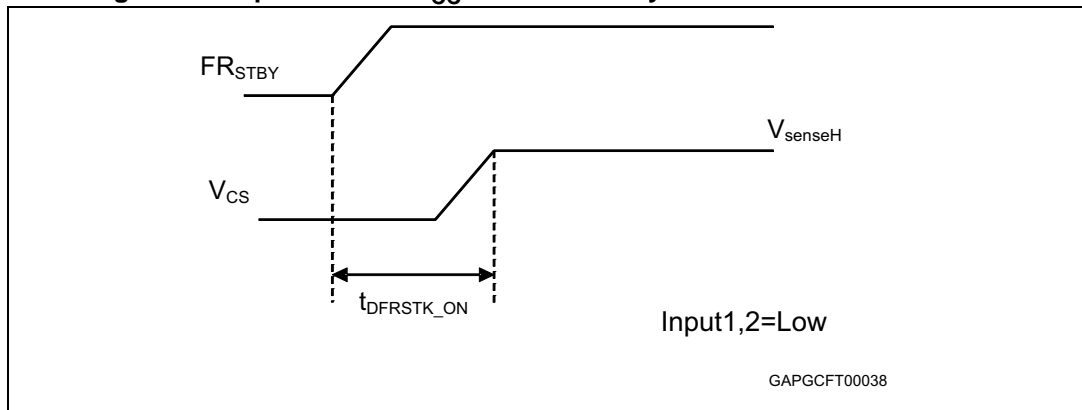


Figure 10. Delay response time between rising edge of output current and rising edge of current sense

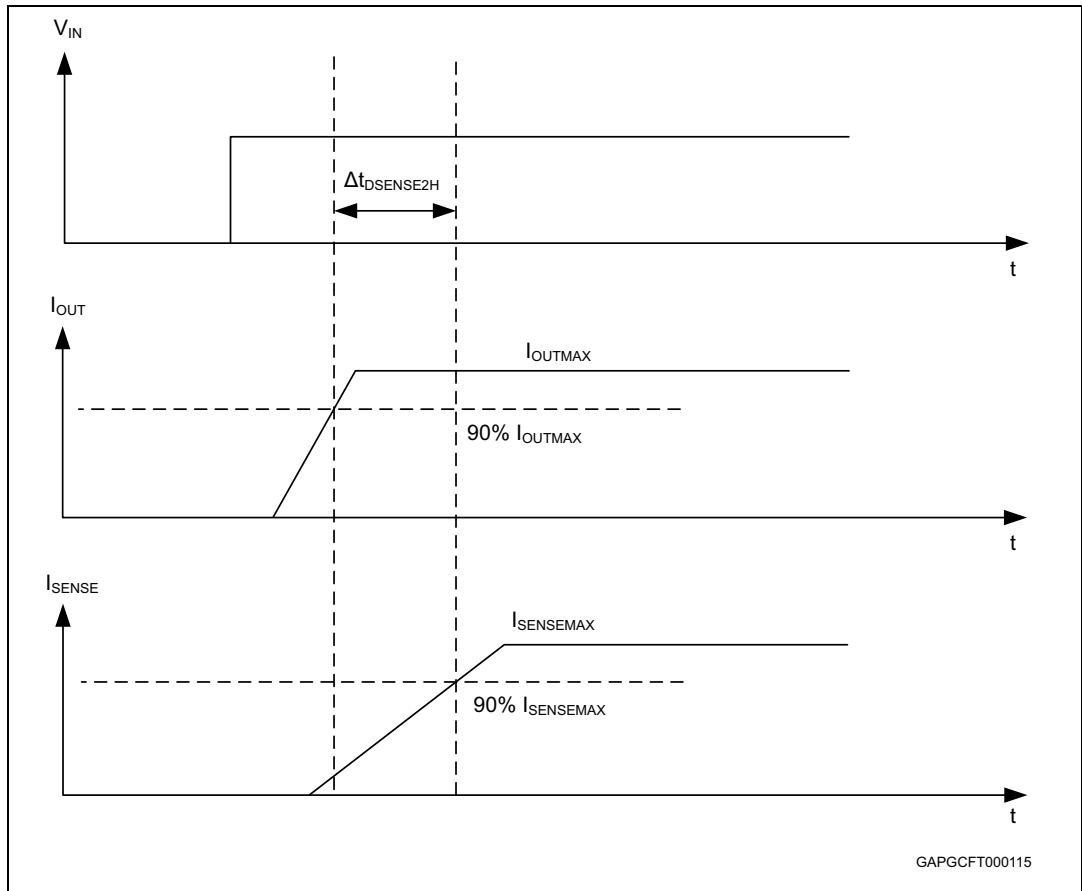


Figure 11. Output voltage drop limitation

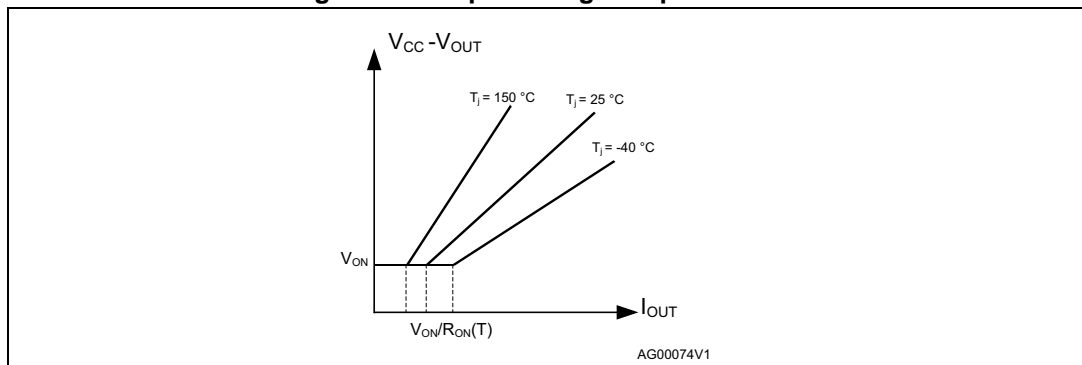


Figure 12. Device behavior in overload condition

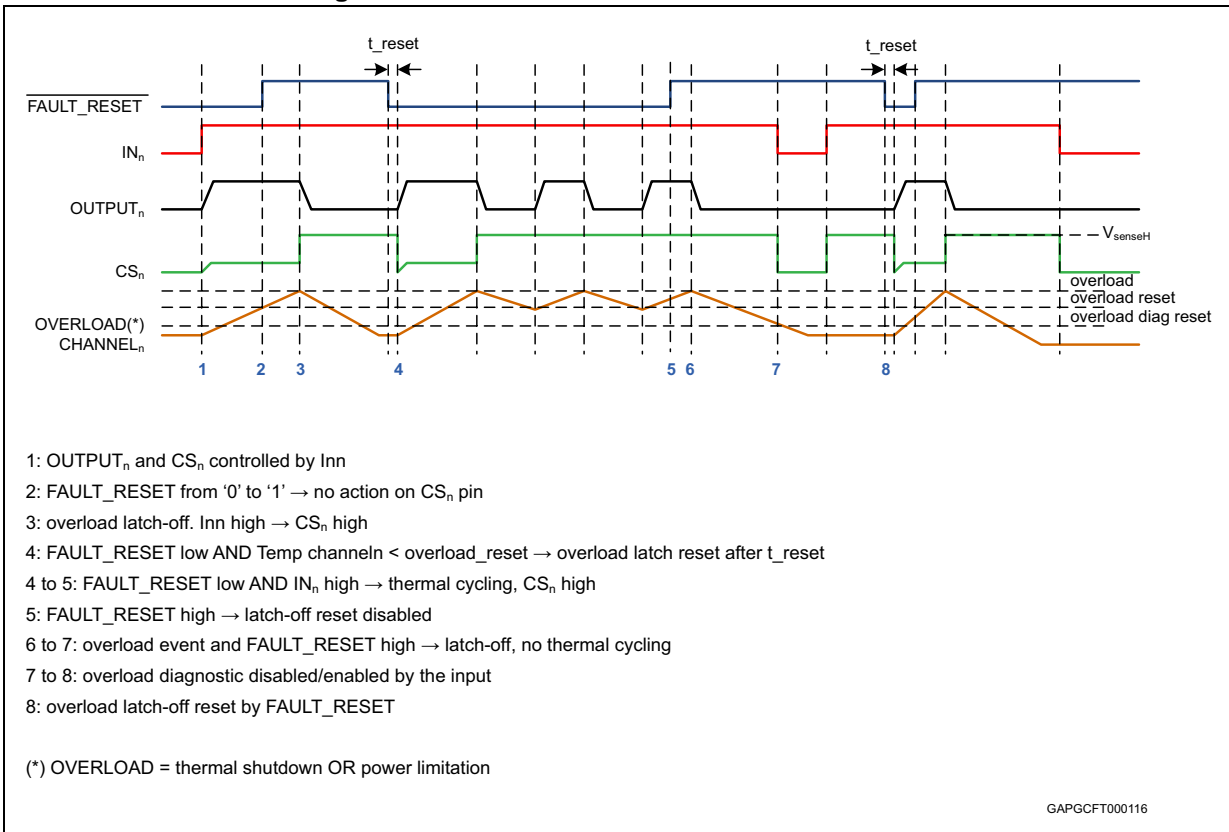


Table 11. Truth table

Conditions	Fault reset standby	Input	Output	Sense
Standby	L	L	L	0
Normal operation	X	L	L	0
	X	H	H	Nominal
Overload	X	L	L	0
	X	H	H	> Nominal
Overtemperature / short to ground	X	L	L	0
	L	H	Cycling	$V_{SENSEH}$
	H	H	Latched	$V_{SENSEH}$
Undervoltage	X	X	L	0
Short to $V_{BAT}$	L	L	H	0
	H	L	H	$V_{SENSEH}$
	X	H	H	< Nominal
Open-load off-state (with pull-up)	L	L	H	0
	H	L	H	$V_{SENSEH}$
	X	H	H	0
Negative output voltage clamp	X	L	Negative	0

**Table 12. Electrical transient requirements (part 1)**

ISO 7637-2: 2004(E) Test pulse	Test levels <sup>(1)</sup>		Number of pulses or test times	Burst cycle/pulse repetition time		Delays and impedance
	III	IV				
1	- 450 V	- 600 V	5000 pulses	0.5 s	5 s	1 ms, 50 Ω
2a	+ 37 V	+ 50 V	5000 pulses	0.2 s	5 s	50 μs, 2 Ω
3a	- 150 V	- 200 V	1h	90 ms	100 ms	0.1 μs, 50 Ω
3b	+ 150 V	+ 200 V	1h	90 ms	100 ms	0.1 μs, 50 Ω
4	- 12 V	- 16 V	1 pulse			100 ms, 0.01 Ω
5b <sup>(2)</sup>	+ 123 V	+ 174 V	1 pulse			350 ms, 1 Ω

**Table 13. Electrical transient requirements (part 2)**

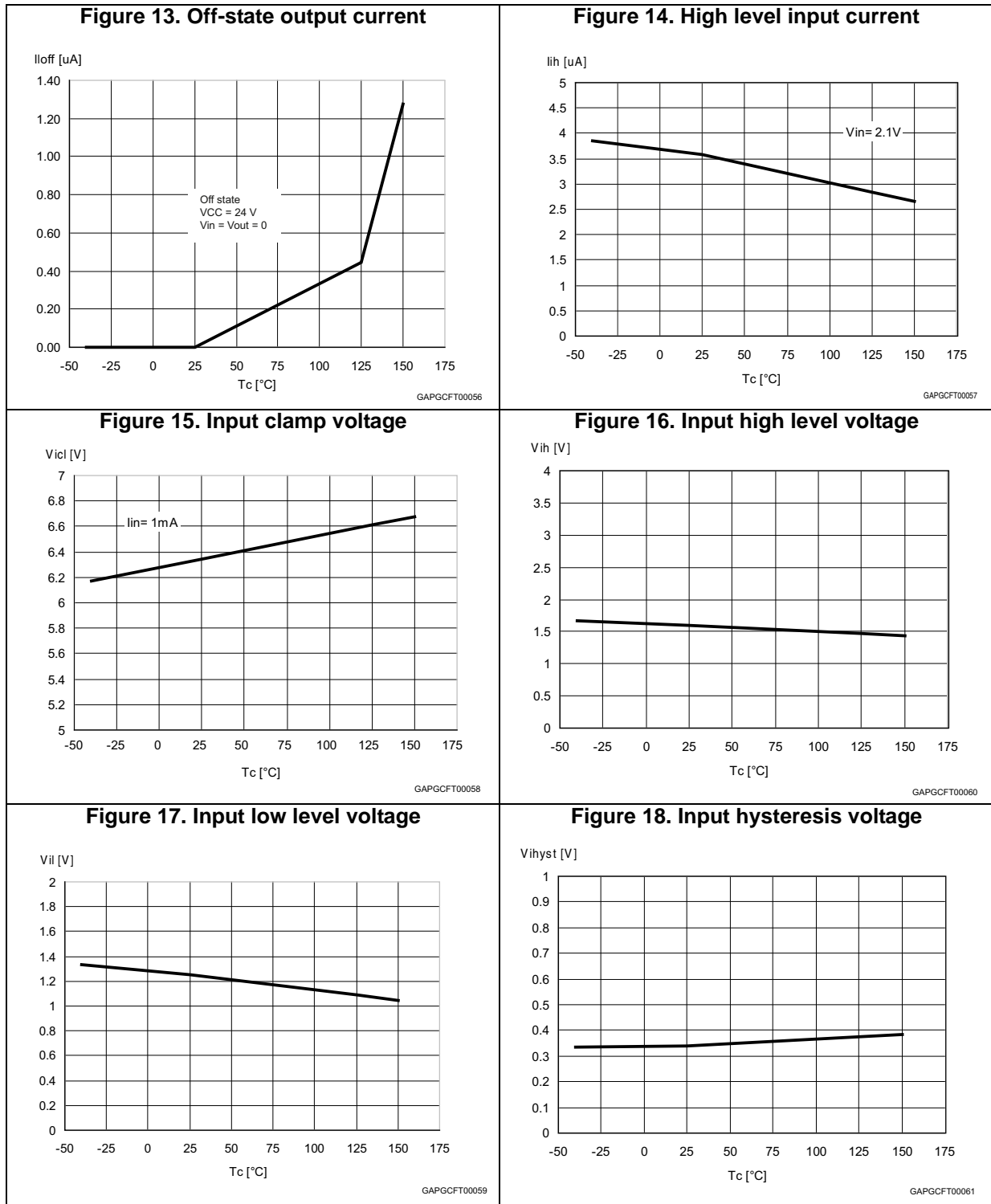
ISO 7637-2: 2004(E) Test pulse	Test level results	
	III	IV
1	C	C
2a	C	C
3a	C	C
3b <sup>(1)</sup>	E	E
3b <sup>(2)</sup>	C	C
4	C	C
5b <sup>(3)</sup>	C	C

1. Without capacitor between V<sub>CC</sub> and GND.
2. With 10 nF between V<sub>CC</sub> and GND.
3. External load dump clamp, 58 V maximum, referred to ground.

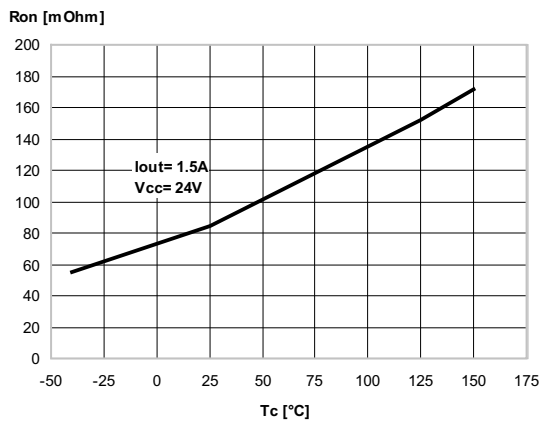
**Table 14. Electrical transient requirements (part 3)**

Class	Contents
C	All functions of the device are performed as designed after exposure to disturbance.
E	One or more functions of the device are not performed as designed after exposure to disturbance and cannot be returned to proper operation without replacing the

## 2.4 Electrical characteristics curves

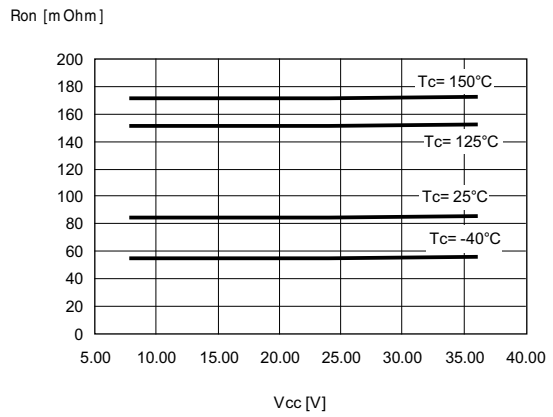


**Figure 19. On-state resistance vs  $T_{case}$**



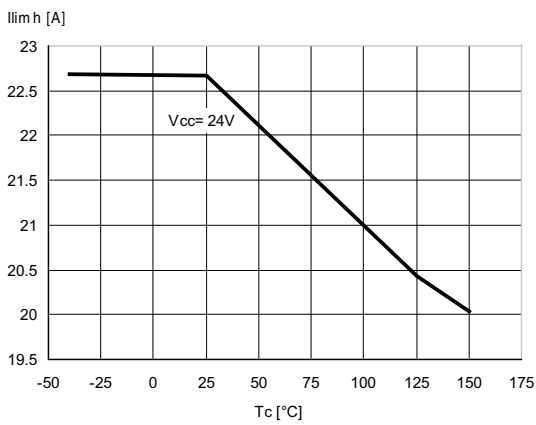
GAPGCF00062

**Figure 20. On-state resistance vs  $V_{CC}$**



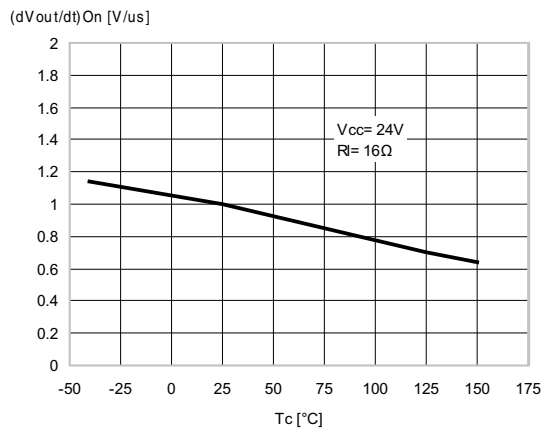
GAPGCF00063

**Figure 21.  $I_{LIMH}$  vs  $T_{case}$**



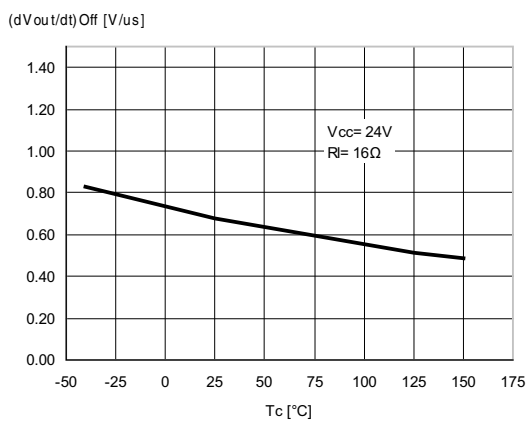
GAPGCF00064

**Figure 22. Turn-on voltage slope**



GAPGCF00065

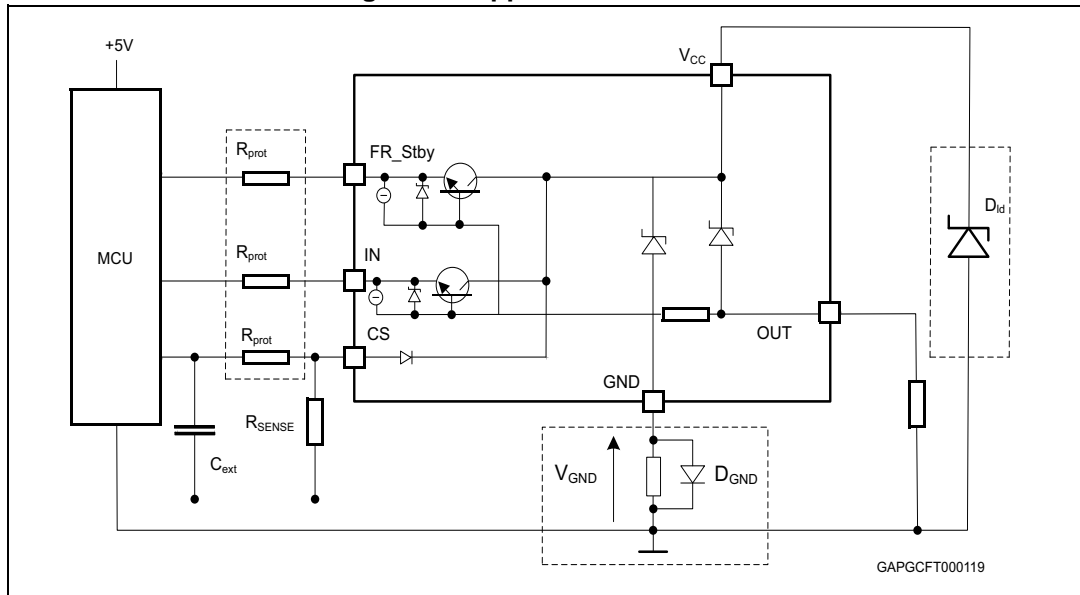
**Figure 23. Turn-off voltage slope**



GAPGCF00066

### 3 Application information

Figure 24. Application schematic



#### 3.1 GND protection network against reverse battery

##### 3.1.1 Solution 1: resistor in the ground line ( $R_{GND}$ only)

This solution can be used with any type of load.

The following is an indication on how to size the  $R_{GND}$  resistor.

1.  $R_{GND} \leq 600 \text{ mV} / (I_{S(on)max})$ .
2.  $R_{GND} \geq (-V_{CC}) / (-I_{GND})$

where  $-I_{GND}$  is the DC reverse ground pin current and can be found in the absolute maximum rating section of the device datasheet.

Power dissipation in  $R_{GND}$  (when  $V_{CC} < 0$ : during reverse battery situations) is:

$$P_D = (-V_{CC})^2 / R_{GND}$$

This resistor can be shared amongst several different HSDs. Please note that the value of this resistor should be calculated with formula (1) where  $I_{S(on)max}$  becomes the sum of the maximum on-state currents of the different devices.

Please note that if the microprocessor ground is not shared by the device ground then the  $R_{GND}$  produces a shift ( $I_{S(on)max} * R_{GND}$ ) in the input thresholds and the status output values. This shift varies depending on how many devices are ON in the case of several high side drivers sharing the same  $R_{GND}$ .

If the calculated power dissipation leads to a large resistor or several devices have to share the same resistor then ST suggests Solution 2 is used (see below).

### 3.1.2 Solution 2: diode ( $D_{GND}$ ) in the ground line

A resistor ( $R_{GND} = 4.7 \text{ k}\Omega$ ) should be inserted in parallel to  $D_{GND}$  if the device drives an inductive load.

This small signal diode can be safely shared amongst several different HSDs. Also in this case, the presence of the ground network produces a shift ( $\approx 600 \text{ mV}$ ) in the input threshold and in the status output values, if the microprocessor ground is not common to the device ground. This shift not varies if more than one HSD shares the same diode/resistor network.

## 3.2 Load dump protection

$D_{ld}$  is necessary (Voltage Transient Suppressor) if the load dump peak voltage exceeds to  $V_{CC}$  maximum DC rating. The same applies if the device is subject to transients on the  $V_{CC}$  line that are greater than the ones shown in the ISO T/R 7637/2 table.

## 3.3 MCU I/Os protection

If a ground protection network is used and negative transient are present on the  $V_{CC}$  line, the control pins are pulled negative. ST suggests that a resistor ( $R_{prot}$ ) be inserted in line to prevent the microcontroller I/O pins from latching-up.

The value of these resistors is a compromise between the leakage current of microcontroller and the current required by the HSD I/Os (Input levels compatibility) with the latch-up limit of microcontroller I/Os.

$$-V_{CCpeak}/I_{latchup} \leq R_{prot} \leq (V_{OH\mu C} - V_{IH} - V_{GND}) / I_{IHmax}$$

Calculation example:

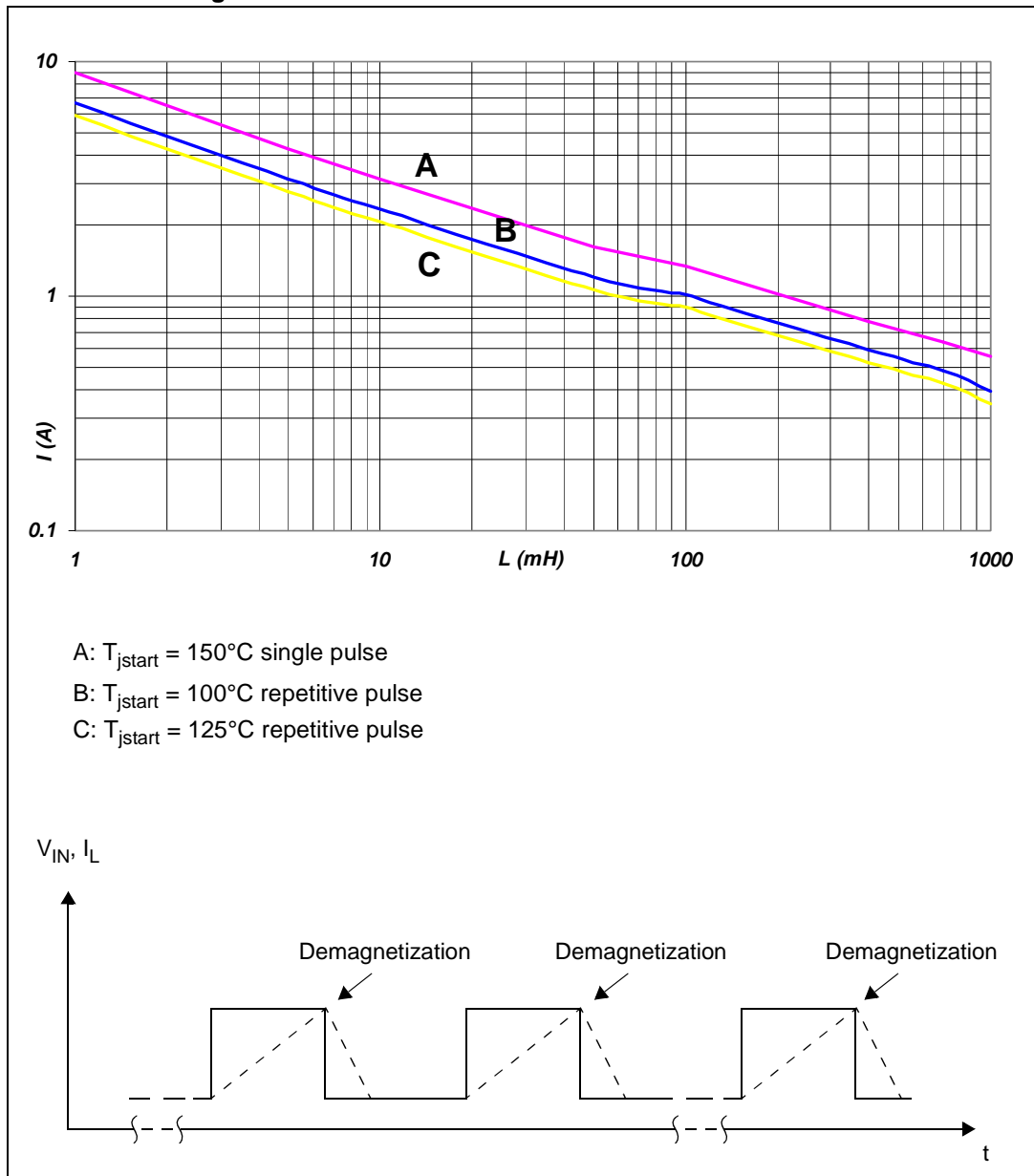
For  $V_{CCpeak} = -600 \text{ V}$  and  $I_{latchup} \geq 20 \text{ mA}$ ;  $V_{OH\mu C} \geq 4.5 \text{ V}$

$$30 \text{ k}\Omega \leq R_{prot} \leq 180 \text{ k}\Omega.$$

Recommended  $R_{prot}$  value is  $60 \text{ k}\Omega$ .

### 3.4 Maximum demagnetization energy ( $V_{CC} = 24\text{ V}$ )

Figure 25. Maximum turn-off current versus inductance

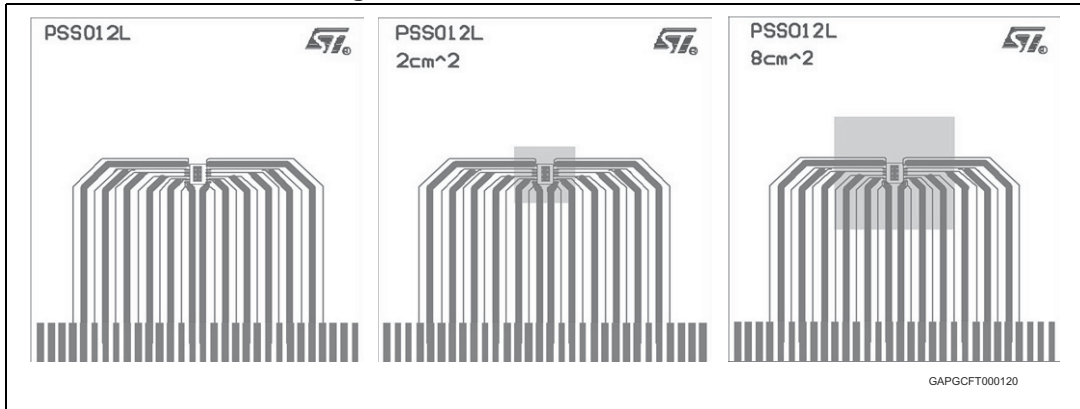


1. Values are generated with  $R_L = 0\ \Omega$ . In case of repetitive pulses,  $T_{jstart}$  (at the beginning of each demagnetization) of every pulse must not exceed the temperature specified above for curves A and B.

## 4 Package and PCB thermal data

### 4.1 PowerSSO-12 thermal data

Figure 26. PowerSSO-12 PC board



1. Layout condition of  $R_{th}$  and  $Z_{th}$  measurements (Board finish thickness 1.6 mm +/- 10 %; Board double layer; Board dimension 77 mm x 86 mm; Board Material FR4; Cu thickness 0.070 mm (front and back side); Thermal vias separation 1.2 mm; Thermal via diameter 0.3 mm +/- 0.08 mm; Cu thickness on vias 0.025 mm; Footprint dimension 4.1 mm x 6.5 mm).

Figure 27.  $R_{thj-amb}$  vs PCB copper area in open box free air condition (one channel ON)

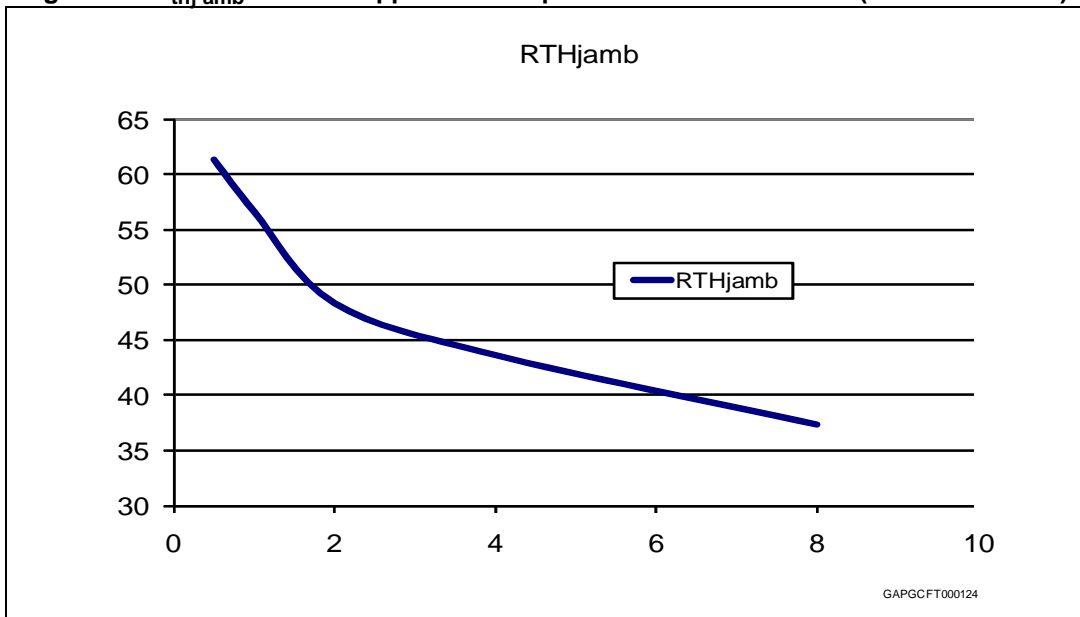


Figure 28. PowerSSO-12 thermal impedance junction ambient single pulse (one channel ON)

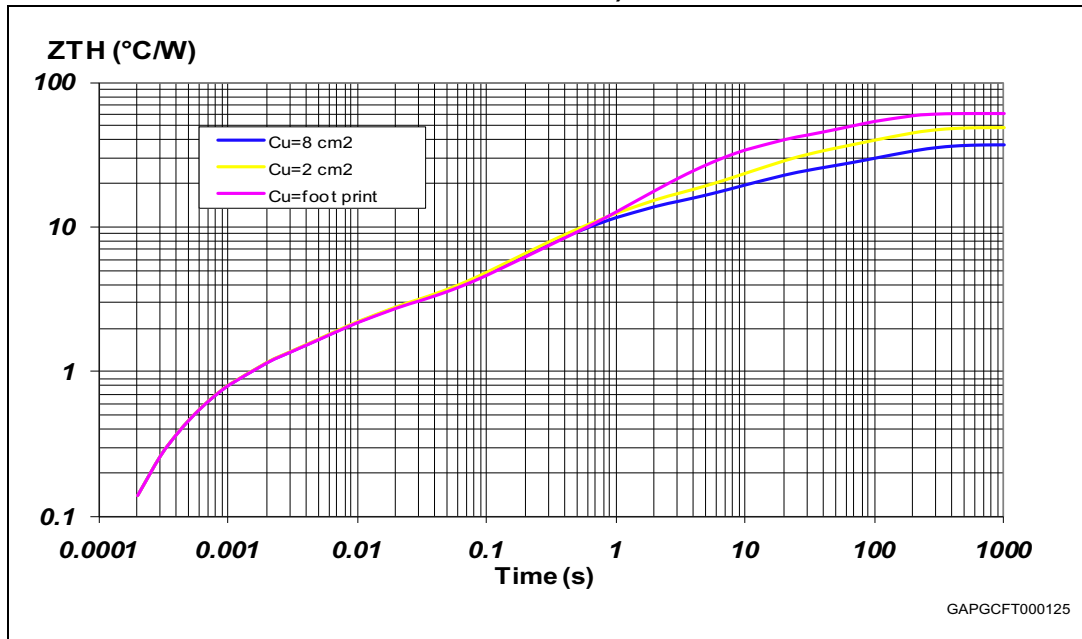
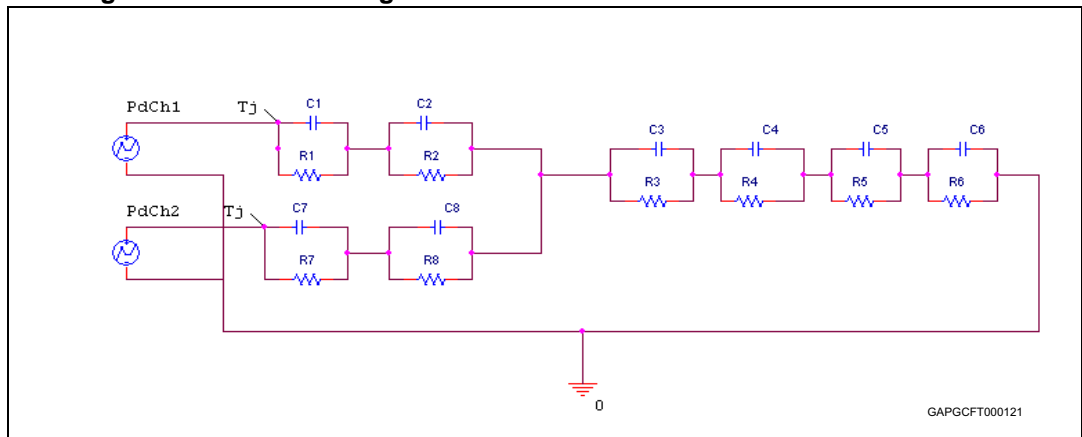


Figure 29. Thermal fitting model of a double channel HSD in PowerSSO-12



1. The fitting model is a simplified thermal tool and is valid for transient evolutions where the embedded protections (power limitation or thermal cycling during thermal shutdown) are not triggered.

**Equation 1: pulse calculation formula**

$$Z_{TH\delta} = R_{TH} \cdot \delta + Z_{THtp}(1 - \delta)$$

where  $\delta = t_p/T$

Table 15. Thermal parameters

Area/island (cm <sup>2</sup> )	Footprint	2	8
R1 = R7 (°C/W)	0.8		
R2 = R8 (°C/W)	1.5		
R3 (°C/W)	3		
R4 (°C/W)	8	8	7
R5 (°C/W)	22	15	10
R6 (°C/W)	26	20	15
C1 = C7 (W.s/°C)	0.0008		
C2 = C8 (W.s/°C)	0.005		
C3 (W.s/°C)	0.05		
C4 (W.s/°C)	0.2	0.1	0.1
C5 (W.s/°C)	0.27	0.8	1
C6 (W.s/°C)	3	6	9

## 5 Package and packing information

In order to meet environmental requirements, ST offers these devices in different grades of ECOPACK® packages, depending on their level of environmental compliance. ECOPACK® specifications, grade definitions and product status are available at: [www.st.com](http://www.st.com).

ECOPACK® is an ST trademark.

### 5.1 PowerSSO-12 mechanical data

Figure 30. PowerSSO-12 package dimensions

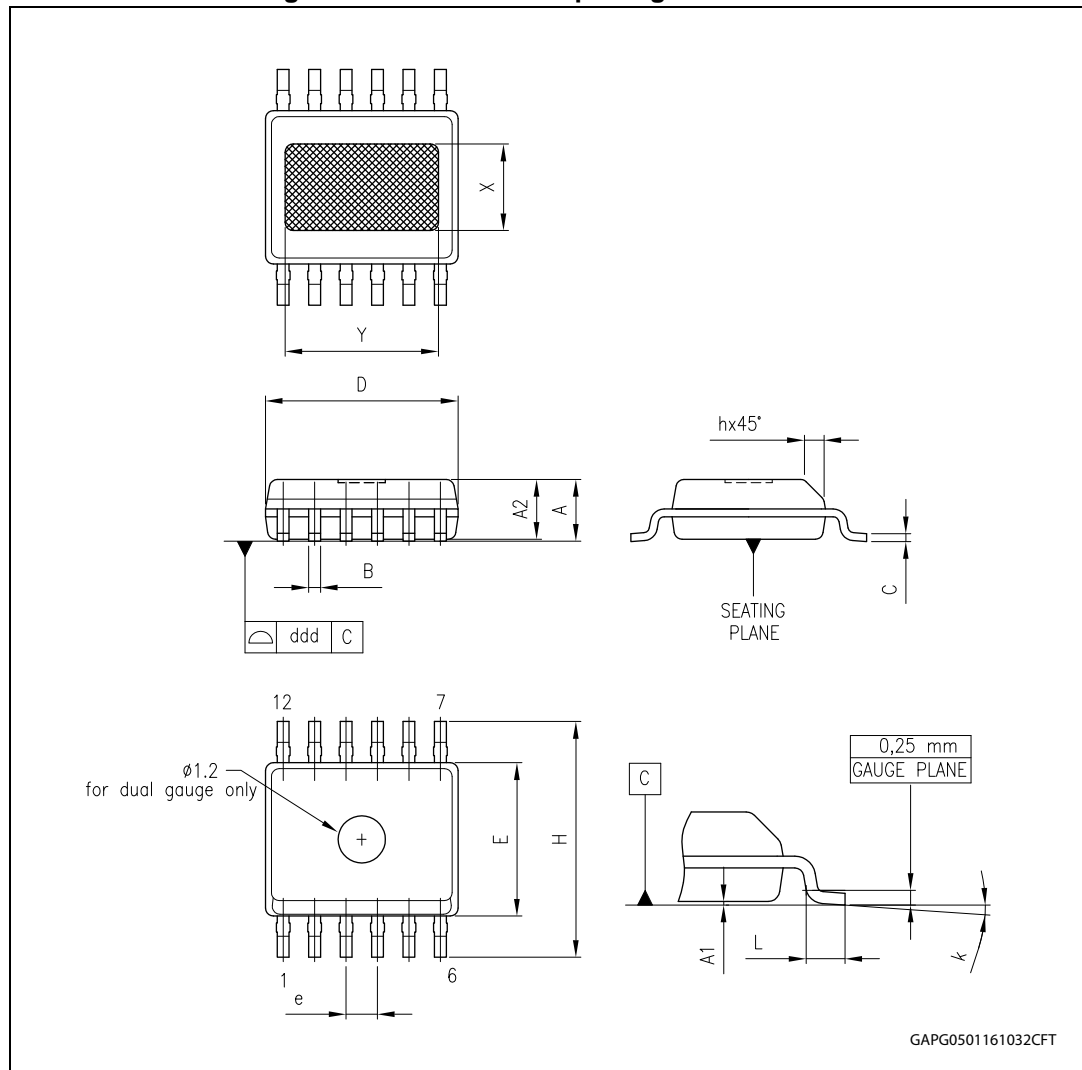


Table 16. PowerSSO-12 mechanical data

Symbol	Millimeters		
	Min.	Typ.	Max.
A	1.250		1.700
A1	0.000		0.100
A2	1.100		1.600
B	0.230		0.410
C	0.190		0.250
D	4.800		5.000
E	3.800		4.000
e		0.800	
H	5.800		6.200
h	0.250		0.550
L	0.400		1.270
k	0°		8°
X	1.900		2.500
Y	3.600		4.200
ddd			0.100

## 5.2 Packing information

Figure 31. PowerSSO-12 tube shipment (no suffix)

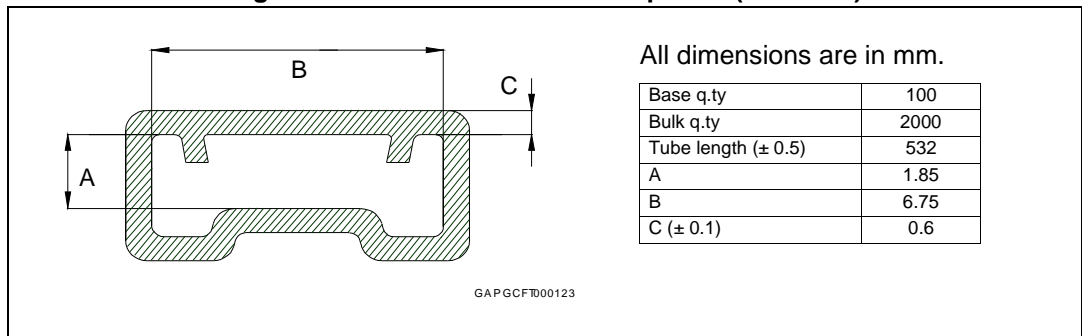
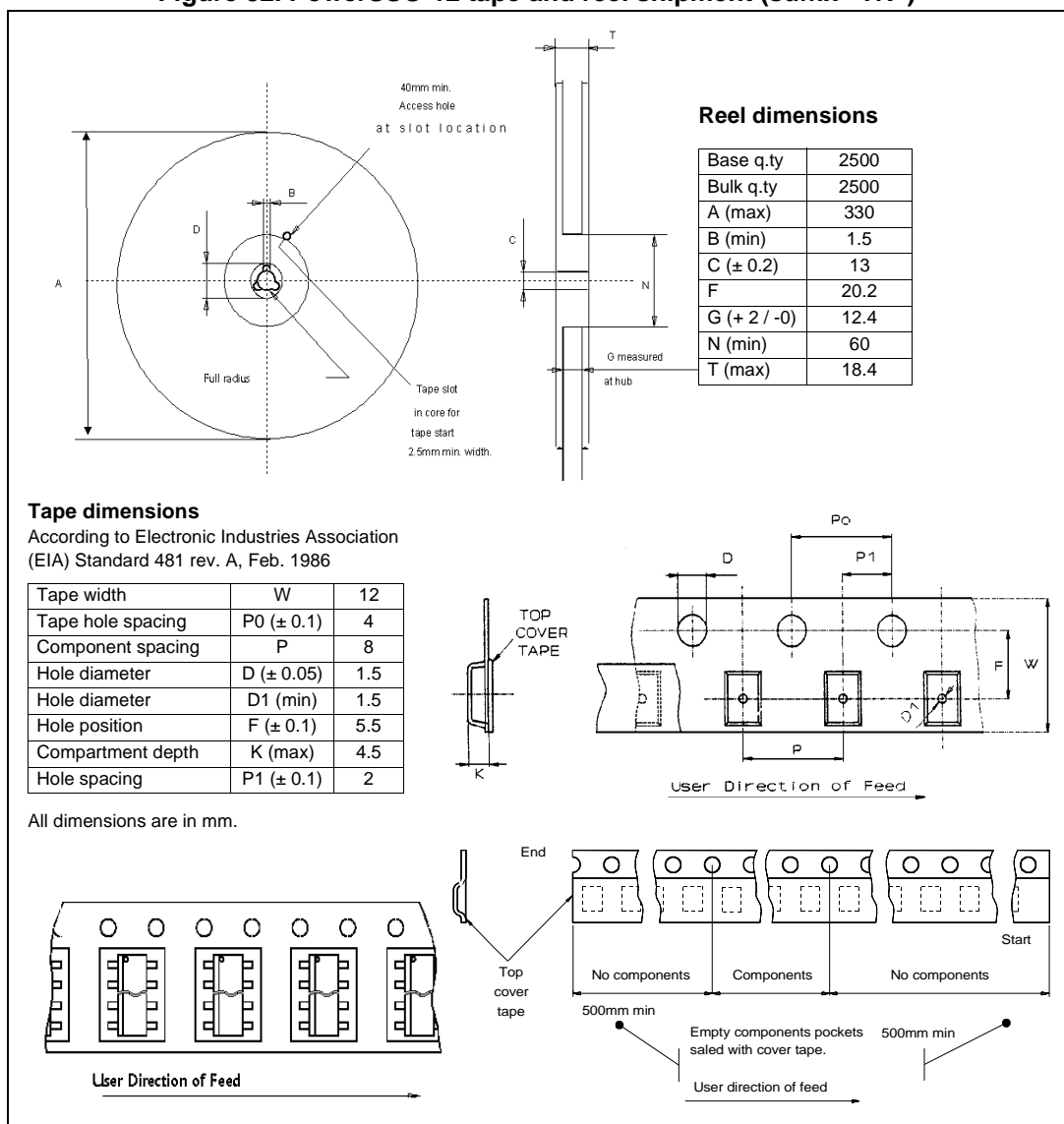


Figure 32. PowerSSO-12 tape and reel shipment (suffix "TR")



## 6 Order code

Table 17. Device summary

Package	Order codes	
	Tube	Tape and reel
PowerSSO-12	VND5T100AJ-E	VND5T100AJTR-E

## 7 Revision history

Table 18. Document revision history

Date	Revision	Changes
08-Mar-2011	1	Initial release.
25-Sep-2013	2	Disclaimer updated.
22-Mar-2016	3	<i>Table 4: Thermal data:</i> – $R_{thj-case}$ : updated value Updated <i>Section 5.1: PowerSSO-12 mechanical data</i>

**IMPORTANT NOTICE – PLEASE READ CAREFULLY**

STMicroelectronics NV and its subsidiaries ("ST") reserve the right to make changes, corrections, enhancements, modifications, and improvements to ST products and/or to this document at any time without notice. Purchasers should obtain the latest relevant information on ST products before placing orders. ST products are sold pursuant to ST's terms and conditions of sale in place at the time of order acknowledgement.

Purchasers are solely responsible for the choice, selection, and use of ST products and ST assumes no liability for application assistance or the design of Purchasers' products.

No license, express or implied, to any intellectual property right is granted by ST herein.

Resale of ST products with provisions different from the information set forth herein shall void any warranty granted by ST for such product.

ST and the ST logo are trademarks of ST. All other product or service names are the property of their respective owners.

Information in this document supersedes and replaces information previously supplied in any prior versions of this document.

© 2016 STMicroelectronics – All rights reserved

## Looking for pricing, stock, or lifecycle information?

Click below to explore more details on WIN SOURCE:

- ⊖ [View EV-VND5T100AJ](#) on WIN SOURCE
- ⊖ [STMicroelectronics](#) Information

## Optimize Your Supply Chain with WIN SOURCE Solutions

- ✓ Global Sourcing Solution
- ✓ Obsolete Management
- ✓ Cost Control Management
- ✓ Shortage Management
- ✓ Alternative Solution
- ✓ Excess Inventory Management