



**THE DATASHEET OF  
CYPD2104-20FNXIT**



## General Description

EZ-PD™ CCG2 is a USB Type-C controller that complies with the latest USB Type-C and PD standards. EZ-PD CCG2 provides a complete USB Type-C and U1SB Power Delivery port control solution for passive cables, active cables, and powered accessories. It can also be used in many upstream and downstream facing port applications. EZ-PD CCG2 uses Cypress's proprietary M0S8 technology with a 32-bit, 48-MHz Arm® Cortex®-M0 processor with 32-KB flash and integrates a complete Type-C Transceiver including the Type-C termination resistors  $R_P$ ,  $R_D$  and  $R_A$ .

## Applications

- USB Type-C EMCA cables
- USB Type-C powered accessories
- USB Type-C upstream facing ports
- USB Type-C downstream facing ports

## Features

### 32-bit MCU Subsystem

- 48-MHz ARM Cortex-M0 CPU
- 32-KB Flash
- 4-KB SRAM
- In-system reprogrammable

### Integrated Digital Blocks

- Integrated timers and counters to meet response times required by the USB-PD protocol
- Run-time reconfigurable serial communication block (SCB) with reconfigurable I<sup>2</sup>C, SPI, or UART functionality

### Clocks and Oscillators

- Integrated oscillator eliminating the need for external clock

## Type-C Support

- Integrated transceiver (baseband PHY)
- Integrated UFP ( $R_D$ ), EMCA ( $R_A$ ) termination resistors, and current sources for DFP ( $R_P$ )
- Supports one USB Type-C port

## Low-Power Operation

- 2.7-V to 5.5-V operation
- Two independent VCONN rails with integrated isolation between the two
- Independent supply voltage pin for GPIO that allows 1.71-V to 5.5-V signaling on the I/Os
- Reset: 1.0  $\mu$ A, Deep Sleep: 2.5  $\mu$ A, Sleep: 2.0 mA

## System-Level ESD on CC and VCONN Pins

- $\pm 8$ -kV Contact Discharge and  $\pm 15$ -kV Air Gap Discharge based on IEC61000-4-2 level 4C

## Packages

- 1.63 mm  $\times$  2.03 mm, 20-ball wafer-level CSP (WLCSPP) with 0.4-mm ball pitch
- 2.5 mm  $\times$  3.5 mm  $\times$  0.6 mm 14-pin DFN
- 4.0 mm  $\times$  4.0 mm, 0.55 mm 24-pin QFN
- Supports industrial ( $-40$  °C to  $+85$  °C) and extended industrial ( $-40$  °C to  $+105$  °C) temperature ranges

## Logic Block Diagram

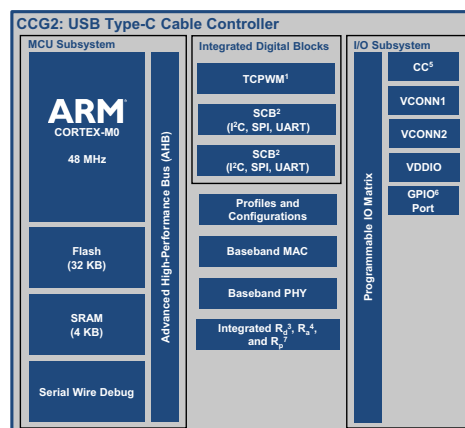

<sup>1</sup> Timer, counter, pulse-width modulation block  
<sup>2</sup> Serial communication block configurable as UART, SPI, or I<sup>2</sup>C  
<sup>3</sup> Termination resistor denoting a UFP  
<sup>4</sup> Termination resistor denoting an EMCA  
<sup>5</sup> Configuration Channel  
<sup>6</sup> General-purpose input/output  
<sup>7</sup> Current Sources to indicate a DFP

## Available Firmware and Software Tools

### EZ-PD Configuration Utility

The EZ-PD Configuration Utility is a GUI-based Microsoft Windows application developed by Cypress to guide a CCGx user through the process of configuring and programming the chip. The utility allows users to:

1. Select and configure the parameters they want to modify
2. Program the resulting configuration onto the target CCGx device.

The utility works with the Cypress supplied CCG1, CCG2, CCG3, and CCG4 kits, which host the CCGx controllers along with a USB interface. This version of the EZ-PD Configuration Utility supports configuration and firmware update operations on CCGx controllers implementing EMCA and Display Dongle applications. Support for other applications, such as Power Adapters and Notebook port controllers, will be provided in later versions of the utility.

You can download the EZ-PD Configuration Utility and its associated documentation at the following link:

<http://www.cypress.com/documentation/software-and-drivers/ez-pd-configuration-utility>

**Contents**

<b>Functional Overview</b> .....	<b>4</b>	Ordering Code Definitions .....	28
CPU and Memory Subsystem .....	4	<b>Packaging</b> .....	<b>29</b>
USB-PD Subsystem (SS) .....	5	<b>Acronyms</b> .....	<b>32</b>
System Resources .....	5	<b>Document Conventions</b> .....	<b>33</b>
Peripherals .....	6	Units of Measure .....	33
GPIO .....	6	References and Links To Applications Collaterals ....	34
<b>Pinouts</b> .....	<b>7</b>	<b>Document History Page</b> .....	<b>35</b>
<b>Power</b> .....	<b>9</b>	<b>Sales, Solutions, and Legal Information</b> .....	<b>36</b>
<b>Application Diagrams</b> .....	<b>10</b>	Worldwide Sales and Design Support .....	36
<b>Electrical Specifications</b> .....	<b>19</b>	Products .....	36
Absolute Maximum Ratings .....	19	PSoC®Solutions .....	36
Device Level Specifications .....	20	Cypress Developer Community .....	36
Digital Peripherals.....	22	Technical Support .....	36
Memory.....	24		
System Resources.....	25		
<b>Ordering Information</b> .....	<b>28</b>		

Figure 1. EZ-PD CCG2 Block Diagram

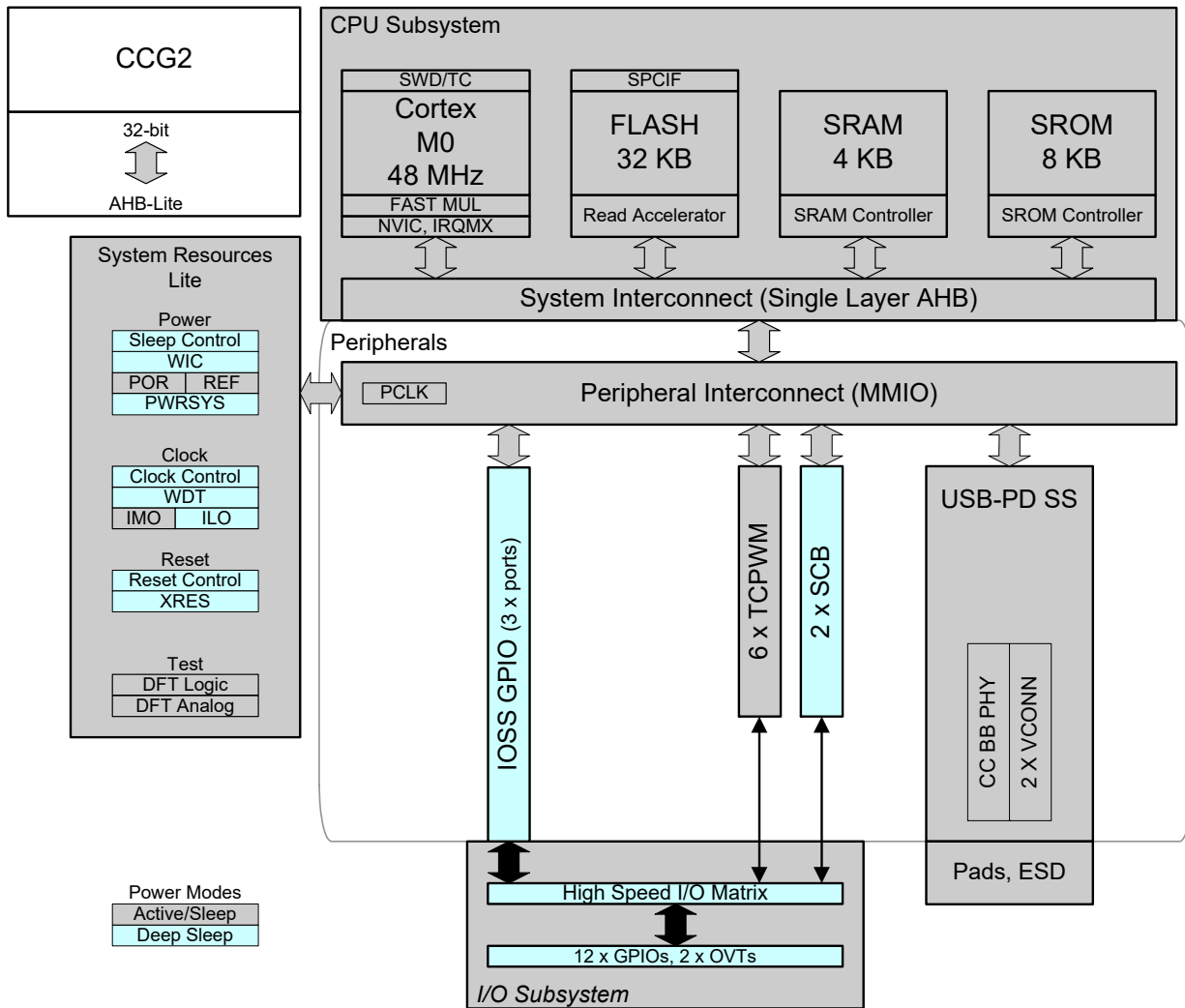

## Functional Overview

### CPU and Memory Subsystem

#### CPU

The Cortex-M0 CPU in EZ-PD CCG2 is part of the 32-bit MCU subsystem, which is optimized for low-power operation with extensive clock gating. It mostly uses 16-bit instructions and executes a subset of the Thumb-2 instruction set. This enables fully compatible binary upward migration of the code to higher performance processors such as the Cortex-M3 and M4, thus enabling upward compatibility. The Cypress implementation includes a hardware multiplier that provides a 32-bit result in one cycle. It includes a nested vectored interrupt controller (NVIC) block with 32 interrupt inputs and also includes a Wakeup Interrupt Controller (WIC). The WIC can wake the processor up from the Deep Sleep mode, allowing power to be switched off to the main processor when the chip is in the Deep Sleep mode. The Cortex-M0 CPU provides a Non-Maskable Interrupt (NMI) input, which is made available to the user when it is not in use for system functions requested by the user.

The CPU also includes a serial wire debug (SWD) interface, which is a 2-wire form of JTAG. The debug configuration used for EZ-PD CCG2 has four break-point (address) comparators and two watchpoint (data) comparators.

#### Flash

The EZ-PD CCG2 device has a flash module with a flash accelerator, tightly coupled to the CPU to improve average access times from the flash block. The flash block is designed to deliver 1 wait-state (WS) access time at 48 MHz and with 0-WS access time at 24 MHz. The flash accelerator delivers 85% of single-cycle SRAM access performance on average. Part of the flash module can be used to emulate EEPROM operation if required.

#### SROM

A supervisory ROM that contains boot and configuration routines is provided.

## USB-PD Subsystem (SS)

EZ-PD CCG2 has a USB-PD subsystem consisting of a USB Type-C baseband transceiver and physical-layer logic. This transceiver performs the BMC and the 4b/5b encoding and decoding functions as well as the 1.2-V front end. This subsystem integrates the required termination resistors to identify the role of the EZ-PD CCG2 solution.  $R_A$  is used to identify EZ-PD CCG2 as an accessory or an electronically marked cable.  $R_D$  is used to identify EZ-PD CCG2 as a UFP in a hybrid cable or a dongle. When configured as a DFP, integrated current sources perform the role of  $R_P$  or pull-up resistors. These current sources can be programmed to indicate the complete range of current capacity on VBUS defined in the Type-C spec. EZ-PD CCG2 responds to all USB-PD communication. The

EZ-PD CCG2 USB-PD sub-system can be configured to respond to SOP, SOP', or SOP'' messaging.

The USB-PD sub-system contains a 8-bit SAR (Successive Approximation Register) ADC for analog to digital conversions. The ADC includes a 8-bit DAC and a comparator. The DAC output forms the positive input of the comparator. The negative input of the comparator is from a 4-input multiplexer. The four inputs of the multiplexer are a pair of global analog multiplexers an internal bandgap voltage and an internal voltage proportional to the absolute temperature. All GPIO inputs can be connected to the global Analog Multiplex Buses through a switch at each GPIO that can enable that GPIO to be connected to the mux bus for ADC use. The CC1, CC2 and RD1 pins are not available to connect to the mux busses.

**Figure 2. USB-PD Subsystem**

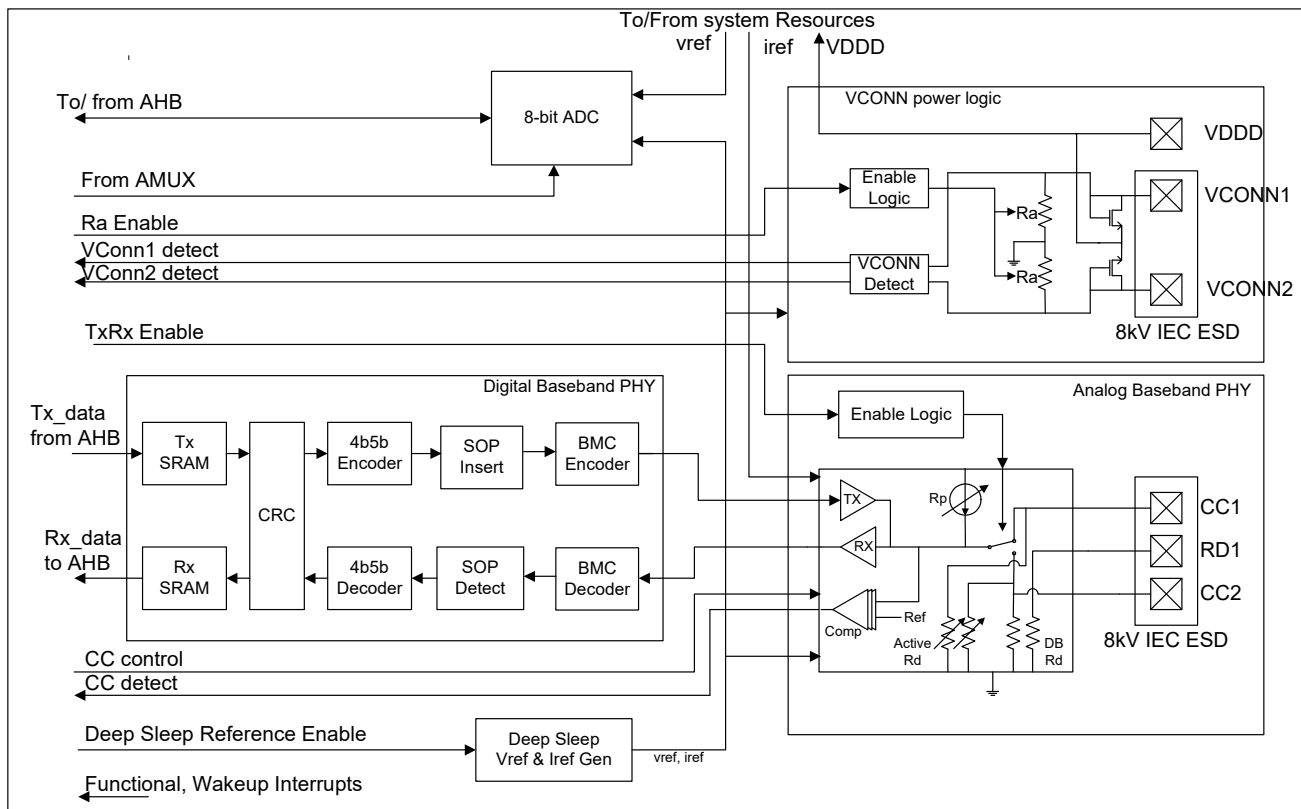

## System Resources

### Power System

The power system is described in detail in the section [Power on page 9](#). It provides assurance that voltage levels are as required for each respective mode and either delay mode entry (on power-on reset (POR), for example) until voltage levels are as required for proper function or generate resets (Brown-Out Detect (BOD)) or interrupts (Low Voltage Detect (LVD)). EZ-PD CCG2 can operate from three different power sources over the range of 2.7 to 5.5 V and has three different power modes, transitions between which are managed by the power system. EZ-PD CCG2 provides Sleep and Deep Sleep low-power modes.

### Clock System

The clock system for EZ-PD CCG2 consists of the Internal Main Oscillator (IMO) and the Internal Low-power Oscillator (ILO).

## Peripherals

### Serial Communication Blocks (SCB)

EZ-PD CCG2 has two SCBs, which can be configured to implement an I<sup>2</sup>C, SPI, or UART interface. The hardware I<sup>2</sup>C blocks implement full multi-master and slave interfaces capable of multimaster arbitration. In the SPI mode, the SCB blocks can be configured to act as master or slave.

In the I<sup>2</sup>C mode, the SCB blocks are capable of operating at speeds of up to 1 Mbps (Fast Mode Plus) and have flexible buffering options to reduce interrupt overhead and latency for the CPU. These blocks also support I<sup>2</sup>C that creates a mailbox address range in the memory of EZ-PD CCG2 and effectively reduce I<sup>2</sup>C communication to reading from and writing to an array in memory. In addition, the blocks support 8-deep FIFOs for receive and transmit which, by increasing the time given for the CPU to read data, greatly reduce the need for clock stretching caused by the CPU not having read data on time.

The I<sup>2</sup>C peripherals are compatible with the I<sup>2</sup>C Standard-mode, Fast-mode, and Fast-mode Plus devices as defined in the NXP I<sup>2</sup>C-bus specification and user manual (UM10204). The I<sup>2</sup>C bus I/Os are implemented with GPIO in open-drain modes.

The I<sup>2</sup>C port on SCB 1 block of EZ-PD CCG2 is not completely compliant with the I<sup>2</sup>C spec in the following respects:

- The GPIO cells for SCB 1's I<sup>2</sup>C port are not overvoltage-tolerant and, therefore, cannot be hot-swapped or powered up independently of the rest of the I<sup>2</sup>C system.
- Fast-mode Plus has an I<sub>OL</sub> specification of 20 mA at a V<sub>OL</sub> of 0.4 V. The GPIO cells can sink a maximum of 8-mA I<sub>OL</sub> with a V<sub>OL</sub> maximum of 0.6 V.
- Fast-mode and Fast-mode Plus specify minimum Fall times, which are not met with the GPIO cell; Slow strong mode can help meet this spec depending on the bus load.

### Timer/Counter/PWM Block (TCPWM)

EZ-PD CCG2 has six TCPWM blocks. Each implements a 16-bit timer, counter, pulse-width modulator (PWM), and quadrature decoder functionality. The block can be used to measure the period and pulse width of an input signal (timer), find the number of times a particular event occurs (counter), generate PWM signals, or decode quadrature signals.

## GPIO

EZ-PD CCG2 has up to 10 GPIOs in addition to the I<sup>2</sup>C and SWD pins, which can also be used as GPIOs. The I<sup>2</sup>C pins from SCB 0 are overvoltage-tolerant. The number of available GPIOs vary with the package. The GPIO block implements the following:

- Seven drive strength modes:
  - Input only
  - Weak pull-up with strong pull-down
  - Strong pull-up with weak pull-down
  - Open drain with strong pull-down
  - Open drain with strong pull-up
  - Strong pull-up with strong pull-down
  - Weak pull-up with weak pull-down
- Input threshold select (CMOS or LVTTTL)
- Individual control of input and output buffer enabling/disabling in addition to the drive strength modes
- Hold mode for latching previous state (used for retaining I/O state in Deep Sleep mode)
- Selectable slew rates for dV/dt related noise control to improve EMI

During power-on and reset, the I/O pins are forced to the disable state so as not to crowbar any inputs and/or cause excess turn-on current. A multiplexing network known as a high-speed I/O matrix is used to multiplex between various signals that may connect to an I/O pin.

## Pinouts

Group	Name	Pin Map 24-QFN	Ball Location 20-CSP	Pin Map 14-DFN	Description
USB Type-C Port	CC1	2	B4	3	USB PD connector detect/Configuration Channel 1
	CC2	1	A4	N/A	USB PD connector detect/Configuration Channel 2
	RD1	3	B3	N/A	Dedicated Rd resistor pin for CC1 Must be left open for cable applications and connected together with CC1 ball for UFP or DFP with dead battery applications
GPIOs and serial interfaces	GPIO	22	C3	N/A	GPIO / SPI_0_CLK / UART_0_RX
	GPIO	18	D3	13	GPIO / SPI_0_MOSI / UART_0_TX
	GPIO	13	C2	10	GPIO / I2C_1_SDA / SPI_1_MISO / UART_1_RX
	GPIO	10	D2	N/A	GPIO / I2C_1_SCL / SPI_1_CLK / UART_1_TX
	GPIO	15	B2	11	GPIO / SPI_1_SEL / UART_1_RTS
	GPIO	14	N/A	N/A	GPIO
	GPIO	17	N/A	N/A	GPIO
	GPIO	21	N/A	N/A	GPIO
	GPIO	23	N/A	N/A	GPIO
	GPIO	24	N/A	N/A	GPIO
	I2C_0_SCL	20	A3	1	GPIO / I2C_0_SCL / SPI_0_MISO / UART_0_RTS
	I2C_0_SDA	19	A2	14	GPIO / I2C_0_SDA / SPI_0_SEL / UART_0_CTS
	SWD_IO	11	E2	8	SWD IO / GPIO / UART_1_CTS / SPI_1_MOSI
SWD_CLK	12	D1	9	SWD clock / GPIO	
RESET	XRES	16	B1	12	Reset input
POWER	VCONN1	5	E4	5	VCONN 1 input (4.0 V to 5.5 V)
	VCONN2	4	C4	4	VCONN 2 input (4.0 V to 5.5 V)
	VDDIO	8	E1	N/A	1.71-V to 5.5-V supply for I/Os
	VCCD	7	A1	6	1.8-V regulator output for filter capacitor
	VDDD	9	E3	7	VDDD supply input/output (2.7 V to 5.5 V)
	VDDD	6			VDDD supply input/output (2.7 V to 5.5 V)
	VSS	EPAD	N/A	EPAD	Ground supply
	VSS		D4	2	Ground supply
	VSS		C1		Ground supply

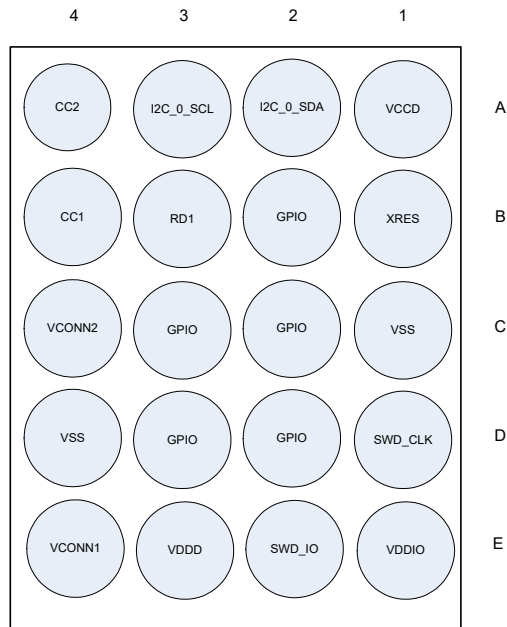
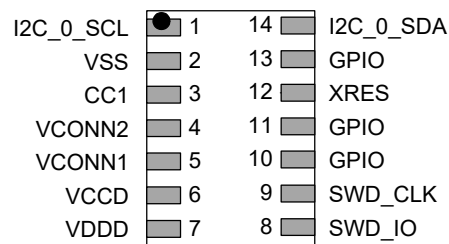
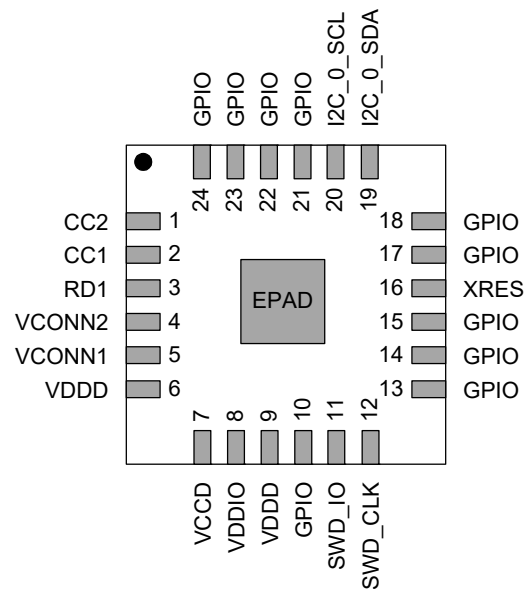
**Figure 3. 20-ball WLCSP EZ-PD CCG2 Ball Map (Bottom (Balls Up) View)**

**Figure 4. 14-pin DFN Pin Map (Top View)**

**Figure 5. 24-Pin QFN Pin Map (Top View)**

## Power

The following power system diagram shows the set of power supply pins as implemented in EZ-PD CCG2.

EZ-PD CCG2 can operate from three different power sources. VCONN1 and VCONN2 pins can be used as connections to the VCONN pins on a Type-C plug of a cable or VCONN-powered accessory. Each of these inputs support operation over 4.0 to 5.5 V. An internal isolation between VCONN1 and VCONN2 pins is provided allowing them to be at different levels simultaneously. CCG2 can be used in EMCA applications with only one or both VCONN pins as power sources. This is illustrated later in the section on Applications. Besides being power inputs, each VCONN pin is also internally connected to a  $R_A$  termination resistor required for EMCA and VCONN-powered accessories.

EZ-PD CCG2 can also be operate from 2.7 to 5.5 V when operated from the VDDD supply pin. VCONN-powered accessory applications require that CCG2 work down to 2.7 V. In such applications, both the VDDD and VCONN pins should be connected to the VCONN pin of the Type-C plug in the accessory.

In UFP, DFP, and DRP applications, CCG2 can be operated from VDDD as the only supply input. In such applications, the VCONN pins are left open. In DFP applications, the lowest VDDD level that CCG2 can operate is 3.0 V due to the need to support disconnect detection thresholds of up to 2.7 V.

A separate I/O supply pin, VDDIO, allows the GPIOs to operate at levels from 1.71 to 5.5 V. The VDDIO pin can be equal to or less than the voltages connected to the VCONN1, VCONN2, and VDDD pins. The independent VDDIO supply is not available on the 14-DFN package. On this package, the VDDIO rail is internally connected to the VDDD rails.

The VCCD output of EZ-PD CCG2 must be bypassed to ground via an external capacitor (in the range of 1 to 1.6  $\mu\text{F}$ ; X5R ceramic or better).

Bypass capacitors must be used from VDDD and VCONN pins to ground; typical practice for systems in this frequency range is to use a 0.1- $\mu\text{F}$  capacitor. Note that these are simply rules of thumb and that for critical applications, the PCB layout, lead inductance, and the bypass capacitor parasitic should be simulated to design and obtain optimal bypassing.

An example of the power supply bypass capacitors is shown in [Figure 6](#).

**Figure 6. EZ-PD CCG2 Power and Bypass Scheme Example**

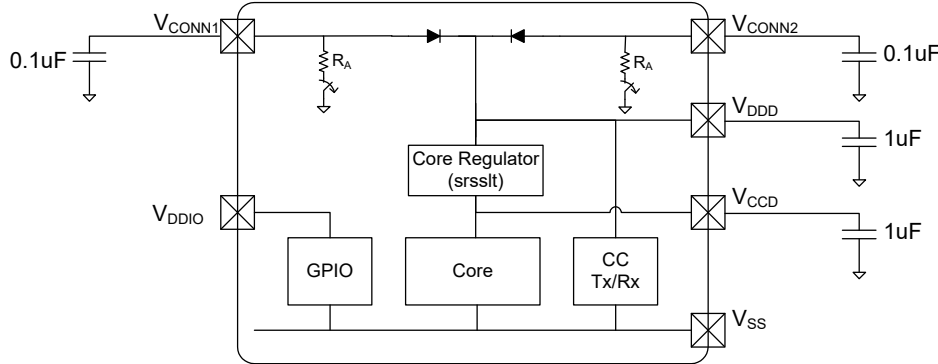

### Application Diagrams

Figure 7 to Figure 10 show the application diagrams of a Passive EMCA application using CCG2 devices. Figure 7 and Figure 8 show the application using a single CCG2 device per cable present at one of the two plugs, whereas Figure 9 and Figure 10 show the same with two CCG2 devices per cable present at each plug. The VBUS signal, the SuperSpeed lines, HighSpeed lines, and CC lines are connected directly from one end to another.

The application diagrams shown in Figure 7 and Figure 8 require a single VCONN wire to run through the cable so that the CCG2

device can be powered irrespective of which plug is connected to the host (DFP). However, in the application diagrams shown in Figure 9 and Figure 10, the VCONN signal does not run through the entire cable, but only runs to the respective VCONN pin of the CCG2 device at each end of the plug. Also, only one CCG2 device is powered at any given instance, depending on which one is nearer to the DFP that supplies VCONN.

**Note:** Application diagram in Figure 8 requires external diodes to operate in the extended VCONN voltage range of 2.7V to 5.5V.

**Figure 7. Passive EMCA Application – Single EZ-PD CCG2 Per Cable (VCONN range between 4.0V to 5.5V)**

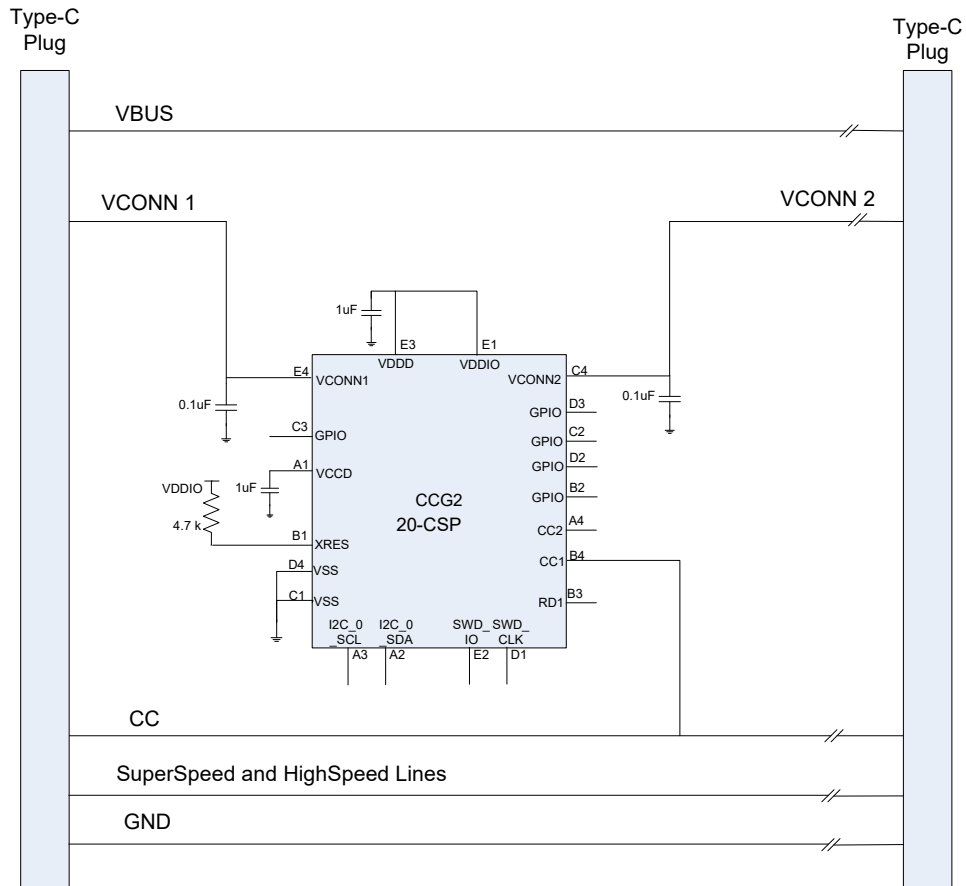

**Figure 8. Passive EMCA Application – Single EZ-PD CCG2 Per Cable (VCONN range between 2.7V to 5.5V)**

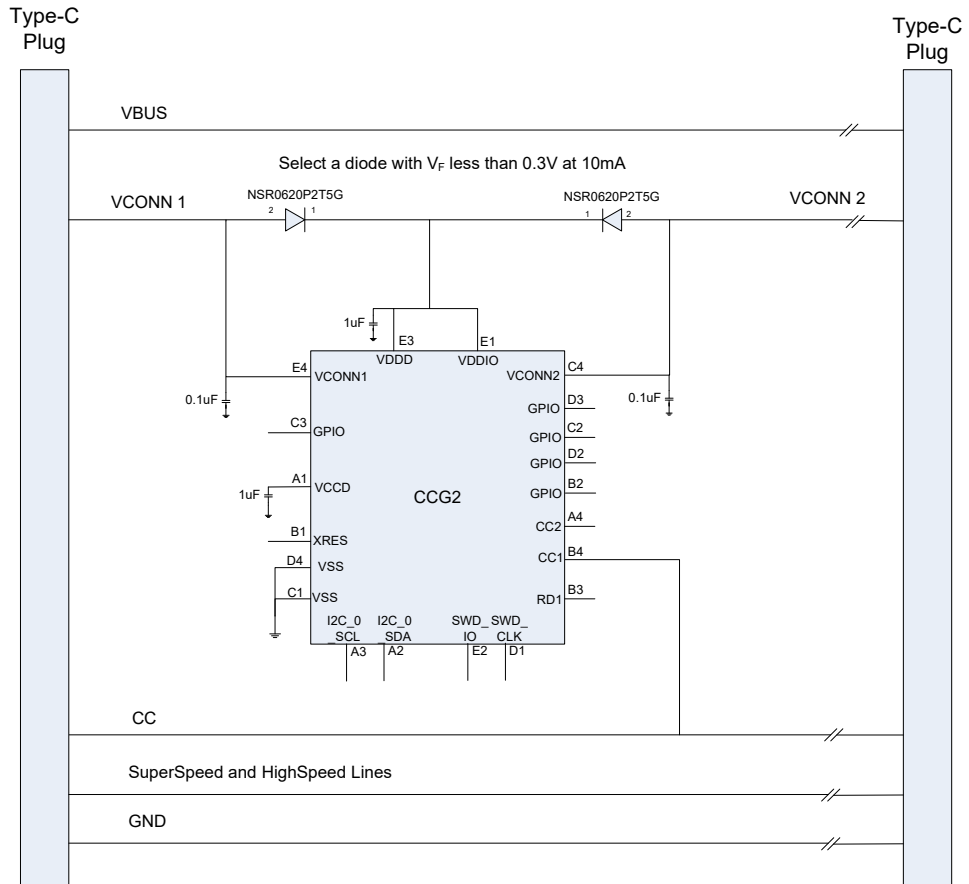

**Figure 9. Passive EMCA Application – Single EZ-PD CCG2 Per Plug (VCONN range between 4.0V to 5.5V)**

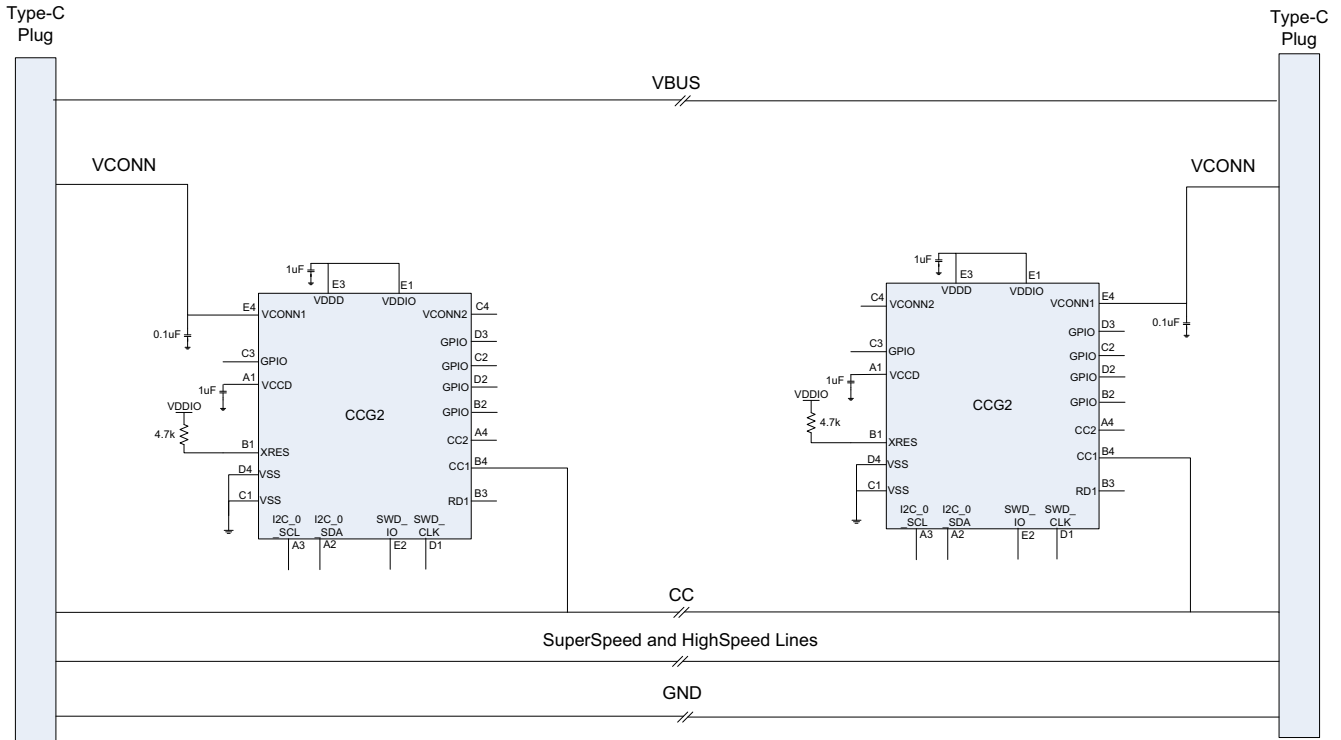

**Figure 10. Passive EMCA Application – Single EZ-PD CCG2 Per Plug (VCONN range between 2.7V to 5.5V)**

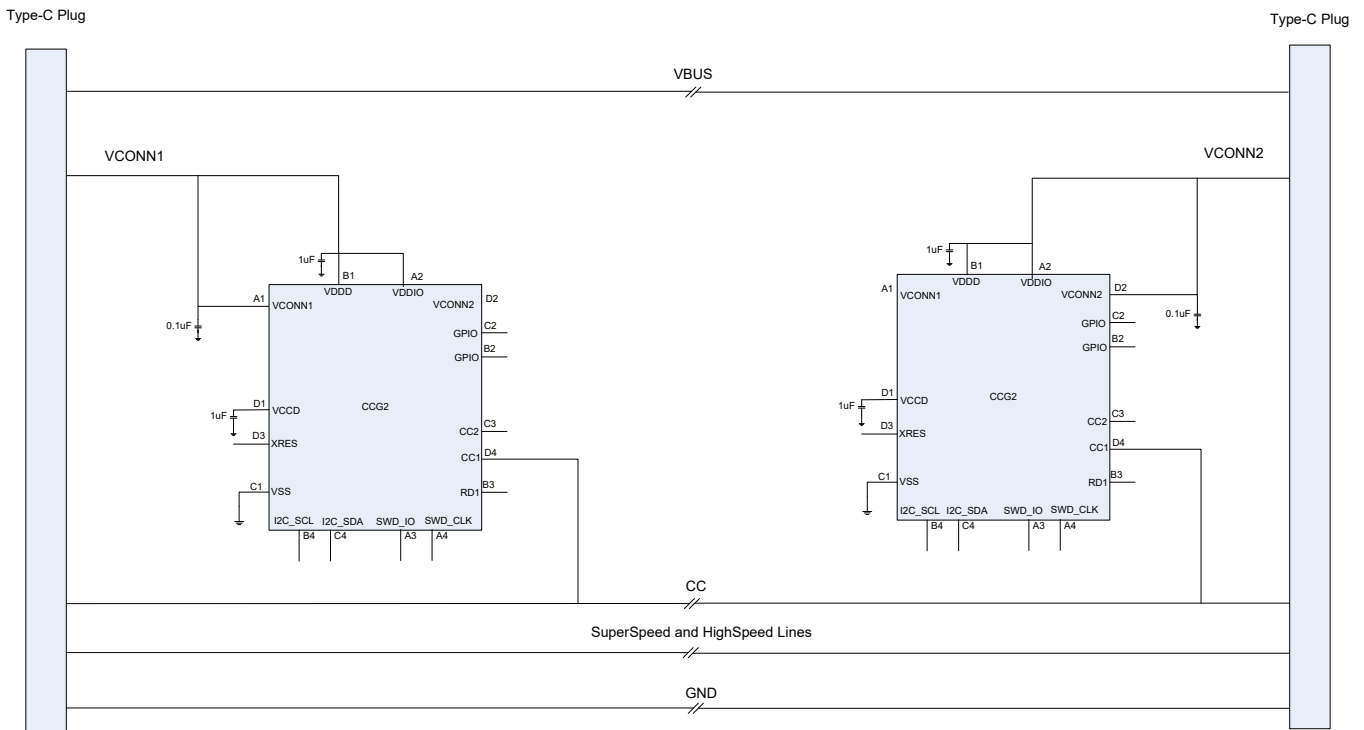

Figure 11 shows a CCG2 device being used in a UFP application (tablet with a Type-C port) only as a power consumer.

The Type-C receptacle brings in HighSpeed and SuperSpeed lines, which are connected directly to the applications processor. The VBUS line from the Type-C receptacle goes directly to the UFP (tablet) charger circuitry. The applications processor communicates over the I<sup>2</sup>C signal with the CCG2 device, and the CC1 and CC2 lines from the Type-C receptacle are connected directly to the respective CC1/2 pins of the CCG2 device.

**Figure 11. Upstream Facing Port (UFP) Application – Tablet with a Type-C Port**

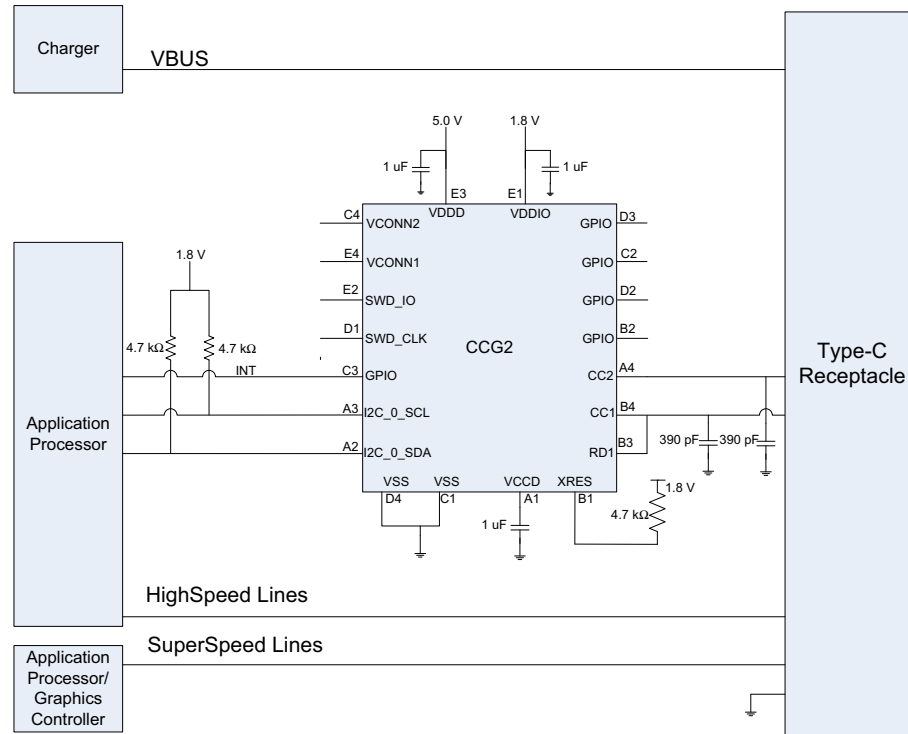

Figure 12 shows a Notebook DRP application diagram using a CCG2 device. The Type-C port can be used as a power provider or a power consumer. The CCG2 device communicates with the Embedded controller (EC) over I<sup>2</sup>C. It also controls the Data Mux to route the High Speed signals either to the USB chipset (during normal mode) or the DisplayPort Chipset (during Alternate Mode). The SBU lines, SuperSpeed and HighSpeed lines are routed directly from the Display Mux of the notebook to the Type-C receptacle.

Optional FETs are provided for applications that need to provide power for accessories and cables using the VCONN pin of the Type-C receptacle. VBUS FETs are also used for providing power over VBUS and for consuming power over VBUS. A VBUS\_DISCHARGE FET controlled by CCG2 device is used to quickly discharge VBUS after the Type-C connection is detached.

**Figure 12. Dual Role Port (DRP) Application**

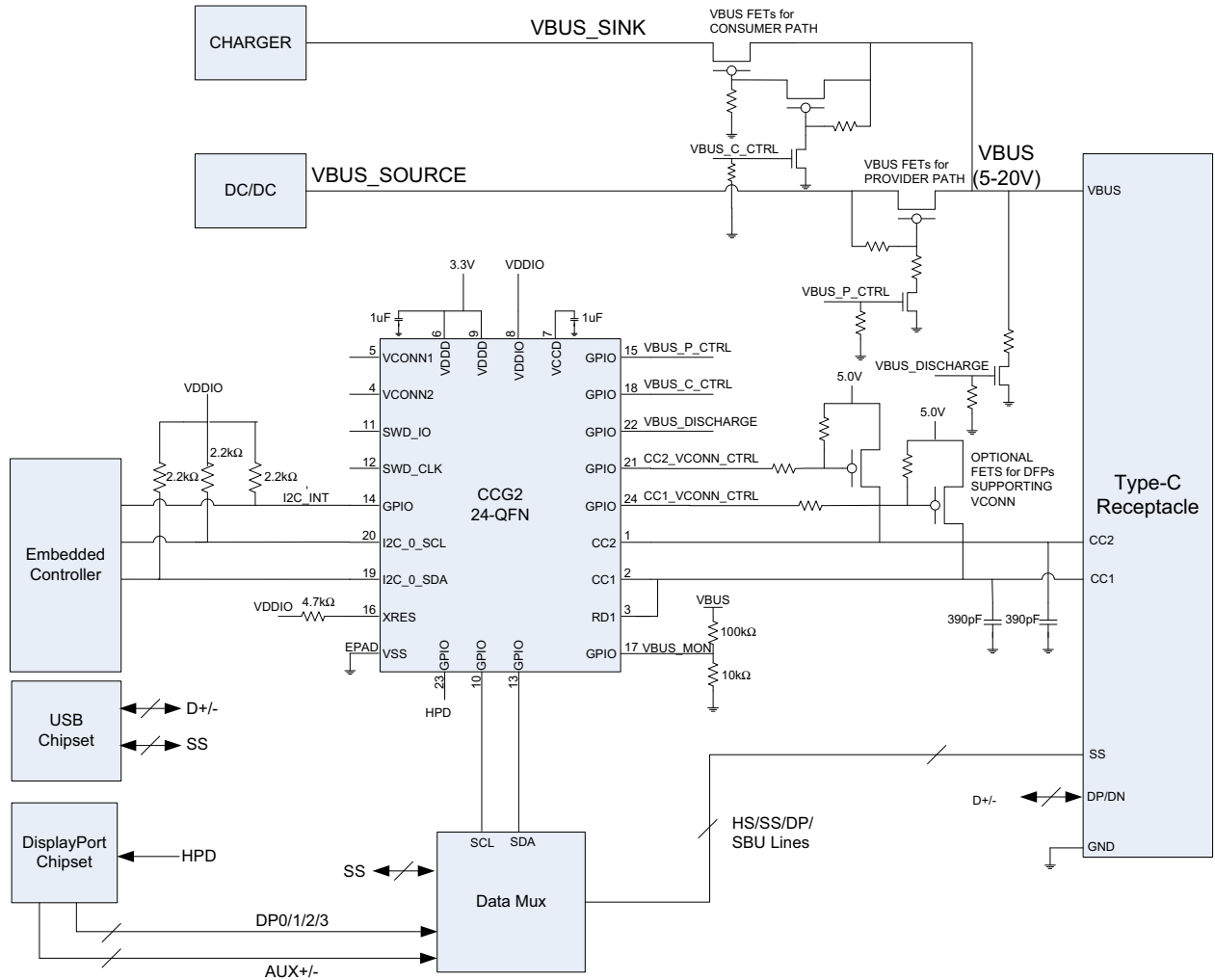

Figure 13 shows a CCG2 receptacle-based Power Adapter application in which the CCG2 device is used as a DFP. CCG2 integrates all termination resistors and uses GPIOs (VSEL\_0 and VSEL\_1) to indicate the negotiated power profile. The VBUS

voltage on the Type-C port is monitored using internal ADC to detect undervoltage and overvoltage conditions on VBUS. To ensure quick discharge of VBUS when the power adapter cable is detached, a discharge path is also provided.

**Figure 13. Downstream Facing Port (DFP) Application**

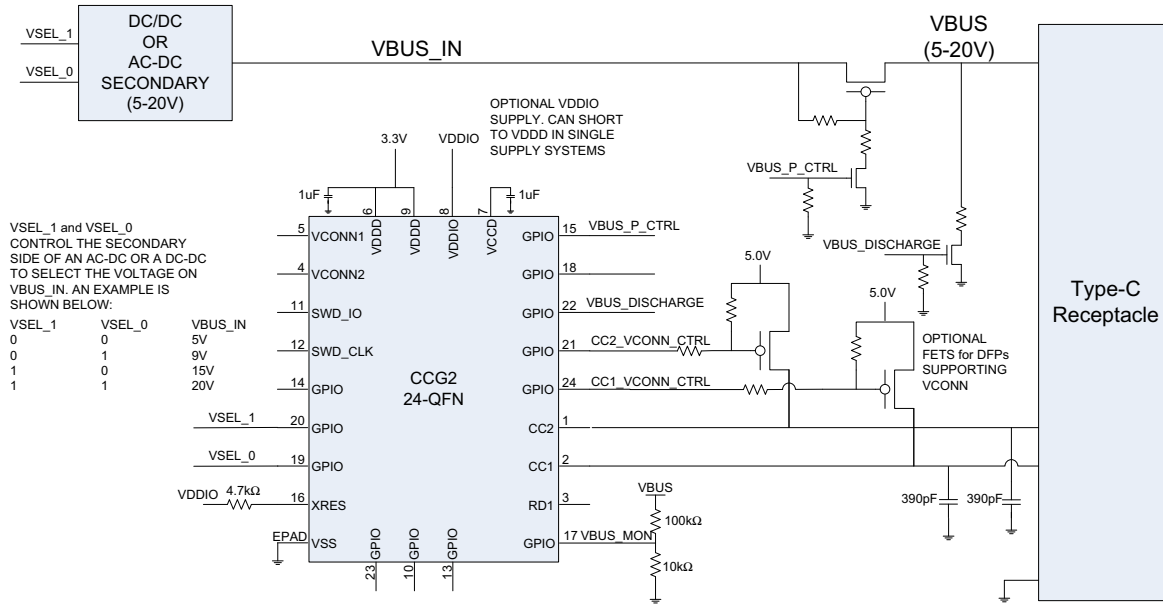

Figure 14 shows a USB Type-C to HDMI/DVI/VGA adapter application, which enables connectivity between a PC that supports a Type-C port with DisplayPort Alternate Mode support and a legacy monitor that has HDMI/DVI/VGA interface. It enables users of any Notebook that implements USB-Type C to connect to other display types.

This application has a Type-C plug on one end and the legacy video (HDMI/DVI/VGA) receptacle on the other end. This appli-

cation meets the requirements described in Section 4.3 of the VESA DisplayPort Alt Mode on USB Type-C Standard Version 1.0. This application supports display output at a resolution of up to 4K Ultra HD (3840x2160) at 60 Hz. It also supports the USB Billboard Device Class, which is required by the USB PD specification for enumeration of any accessories that support Alternate Mode when connected to a host PC.

**Figure 14. USB Type-C to HDMI/DVI/VGA Dongle Application Diagram**

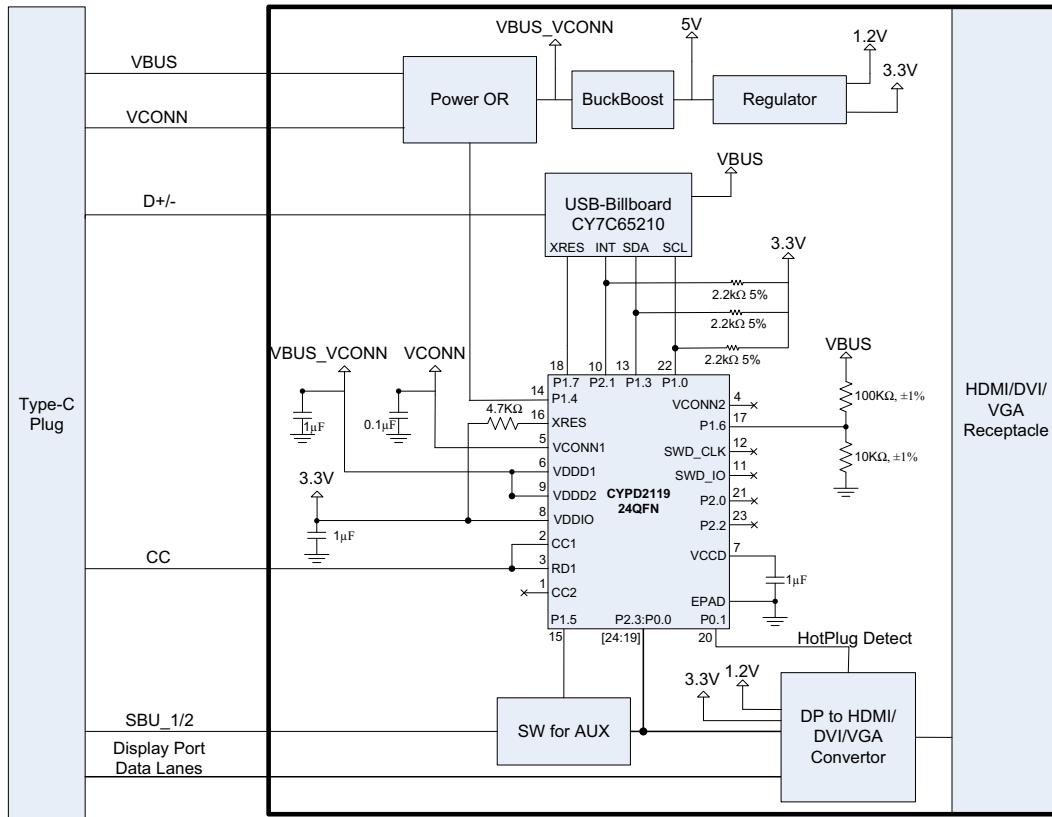

Figure 15 shows a USB Type-C to DisplayPort adapter application, which enables connectivity between a PC that supports a Type-C port with DisplayPort Alternate Mode support and a legacy monitor that has a DisplayPort interface.

It also supports the USB Billboard Device Class, which is required by the USB PD specification for enumeration of any accessories that support Alternate Mode when connected to a host PC.

Figure 15 shows a Type-C plug on one end and a DP/mDP plug on the other end. The application meets the requirements described in Section 4.2 of the VESA DisplayPort Alt Mode on USB Type-C Standard Version 1.0 (Scenarios 2a and 2b USB

**Figure 15. USB Type-C to Display Port Application Diagram**

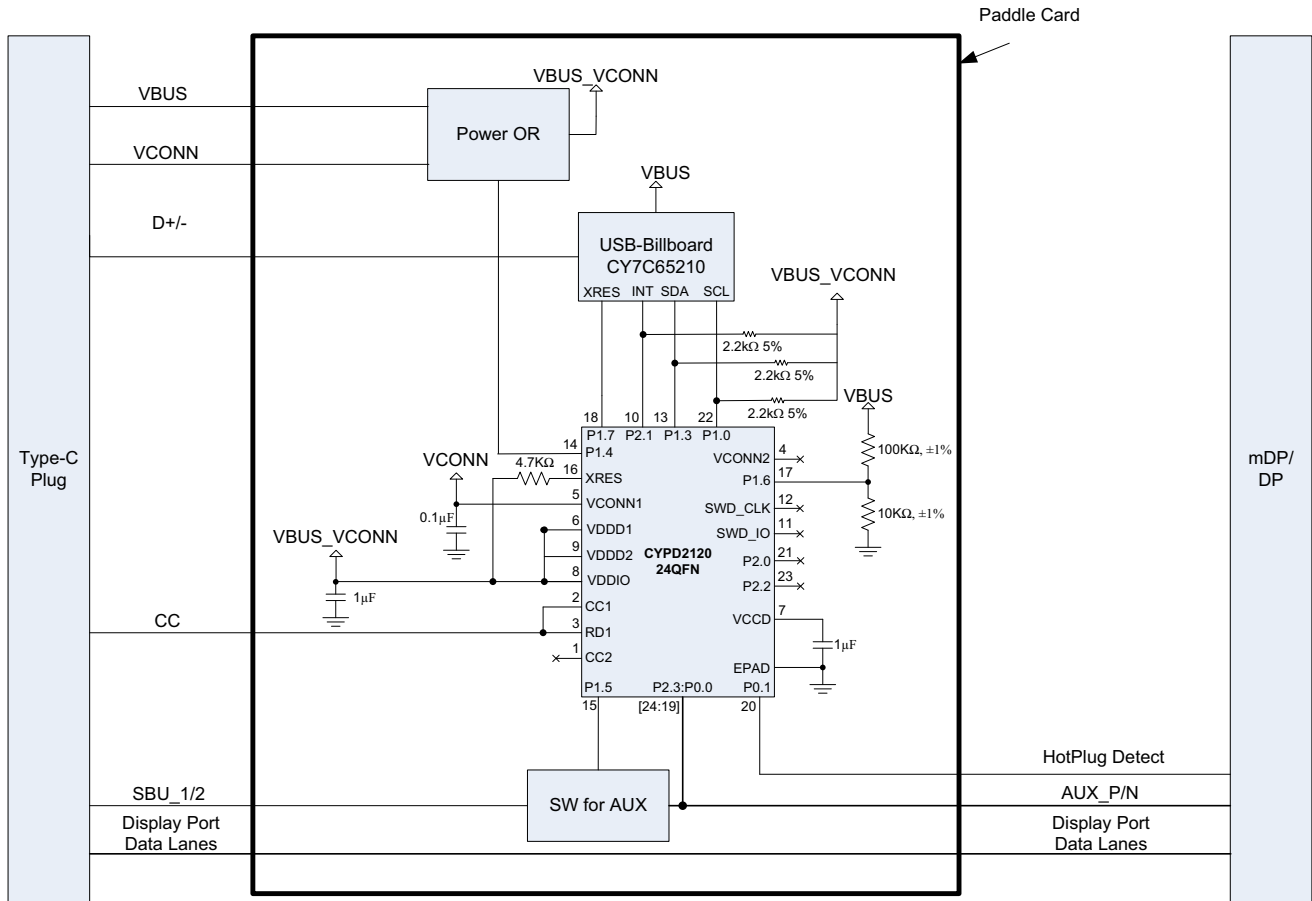
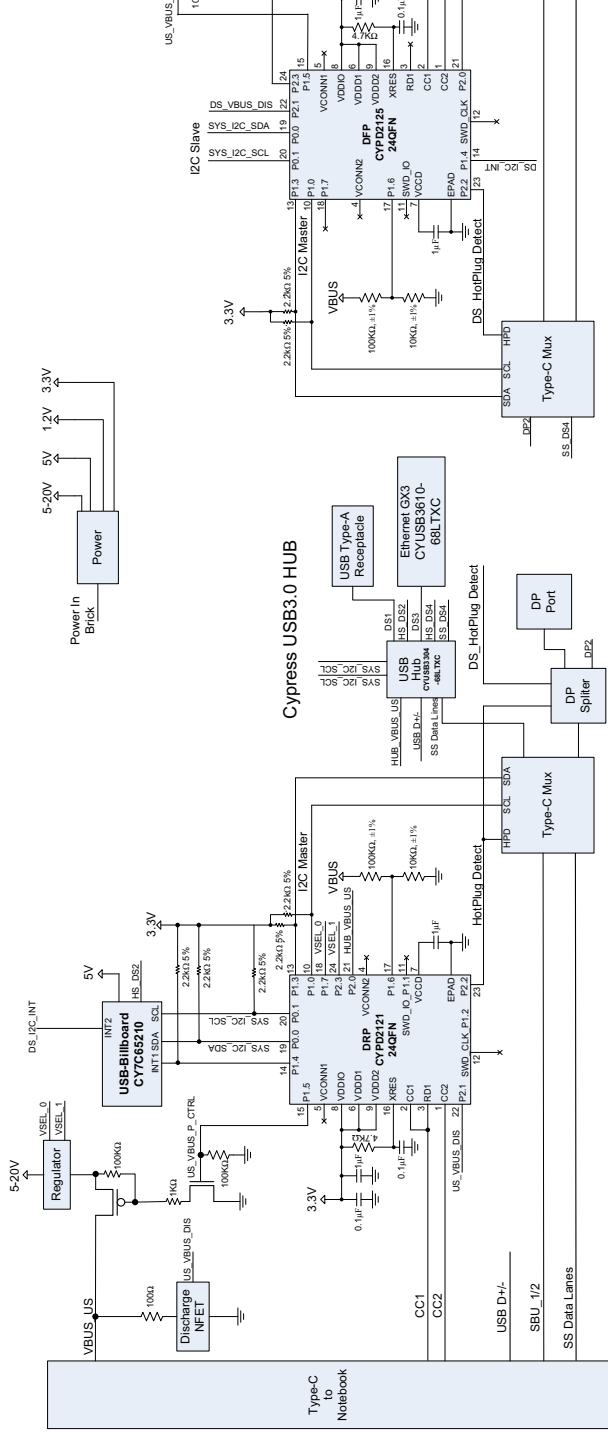

Figure 16 shows a CCG2 Monitor/Dock application diagram. It enables connectivity between a USB Type-C host system on the Upstream port and multiple Display/Data devices on the Downstream port. This application has a USB Type-C receptacle on the Upstream port, which supports data, power, and display. On the Downstream port, this application supports: USB Type-A, Gigabit Ethernet, DisplayPort, and USB Type-C receptacle.

The main features of this solution are:

- Powered from an external 24-V DC power adapter
- Provides up to 45 W (15 V at 3A) on the Upstream Type-C port and up to 15 W (5 V at 3A) on the Downstream USB Type-C port

**Figure 16. CCG2 in Dock/Monitor Application Diagram**



CCG2 connected on the Upstream Port

CCG2 connected on the Downstream

## Electrical Specifications

### Absolute Maximum Ratings

**Table 1. Absolute Maximum Ratings<sup>[1]</sup>**

Parameter	Description	Min	Typ	Max	Units	Details/Conditions
V <sub>DDD_MAX</sub>	Digital supply relative to V <sub>SS</sub>	-0.5	-	6	V	Absolute max
V <sub>CONN1_MAX</sub>	Max supply voltage relative to V <sub>SS</sub>	-	-	6	V	Absolute max
V <sub>CONN2_MAX</sub>	Max supply voltage relative to V <sub>SS</sub>	-	-	6	V	Absolute max
V <sub>DDIO_MAX</sub>	Max supply voltage relative to V <sub>SS</sub>	-	-	6	V	Absolute max
V <sub>GPIO_ABS</sub>	GPIO voltage	-0.5	-	V <sub>DDIO</sub> + 0.5	V	Absolute max
V <sub>CC_ABS</sub>	Absolute max voltage for CC1 and CC2 pins	-	-	6	V	Absolute max
I <sub>GPIO_ABS</sub>	Maximum current per GPIO	-25	-	25	mA	Absolute max
I <sub>GPIO_injection</sub>	GPIO injection current, Max for V <sub>IH</sub> > V <sub>DDD</sub> , and Min for V <sub>IL</sub> < V <sub>SS</sub>	-0.5	-	0.5	mA	Absolute max, current injected per pin
ESD_HBM	Electrostatic discharge human body model	2200	-	-	V	-
ESD_CDM	Electrostatic discharge charged device model	500	-	-	V	-
LU	Pin current for latch-up	-200	-	200	mA	-
ESD_IEC_CON	Electrostatic discharge IEC61000-4-2	8000	-	-	V	Contact discharge on CC1, CC2, VCONN1, and VCONN2 pins
ESD_IEC_AIR	Electrostatic discharge IEC61000-4-2	15000	-	-	V	Air discharge for pins CC1, CC2, VCONN1, and VCONN2

**Note**

- Usage above the absolute maximum conditions listed in Table 1 may cause permanent damage to the device. Exposure to absolute maximum conditions for extended periods of time may affect device reliability. The maximum storage temperature is 150 °C in compliance with JEDEC Standard JESD22-A103, High Temperature Storage Life. When used below absolute maximum conditions but above normal operating conditions, the device may not operate to specification.

## Device Level Specifications

All specifications are valid for  $-40\text{ }^{\circ}\text{C} \leq T_A \leq 85\text{ }^{\circ}\text{C}$  and  $T_J \leq 100\text{ }^{\circ}\text{C}$ , except where noted. Specifications are valid for 3.0 V to 5.5 V, except where noted.

**Table 2. DC Specifications**

Spec ID	Parameter	Description	Min	Typ	Max	Units	Details/Conditions
SID.PWR#1	V <sub>DDD</sub>	Power supply input voltage	2.7	–	5.5	V	UFP Applications
SID.PWR#1_A	V <sub>DDD</sub>	Power supply input voltage	3.0	–	5.5	V	DFP/DRP Applications
SID.PWR#23	V <sub>CONN1</sub>	Power supply input voltage	4.0	–	5.5	V	–
SID.PWR#23_A	V <sub>CONN2</sub>	Power supply input voltage	4.0	–	5.5	V	–
SID.PWR#13	V <sub>DDIO</sub>	GPIO power supply	1.71	–	5.5	V	–
SID.PWR#24	V <sub>CCD</sub>	Output voltage (for core logic)	–	1.8	–	V	–
SID.PWR#15	C <sub>EFC</sub>	External regulator voltage bypass on V <sub>CCD</sub>	1	1.3	1.6	μF	X5R ceramic or better
SID.PWR#16	C <sub>EXC</sub>	Power supply decoupling capacitor on V <sub>DDD</sub>	–	1	–	μF	X5R ceramic or better
SID.PWR#25		Power Supply Decoupling Capacitor on V <sub>CONN1</sub> and V <sub>CONN2</sub>	–	0.1	–	μF	X5R ceramic or better
<b>Active Mode, V<sub>DDD</sub> = 2.7 to 5.5 V. Typical values measured at V<sub>DD</sub> = 3.3 V.</b>							
SID.PWR#12	I <sub>DD12</sub>	Supply current	–	7.5	–	mA	V <sub>CONN1</sub> or V <sub>CONN2</sub> = 5 V, T <sub>A</sub> = 25 °C, CC I/O IN Transmit or Receive, R <sub>A</sub> disconnected, no I/O sourcing current, CPU at 12 MHz
<b>Sleep Mode, V<sub>DDD</sub> = 2.7 to 5.5 V</b>							
SID25A	I <sub>DD20A</sub>	I <sup>2</sup> C wakeup. WDT ON. IMO at 48 MHz	–	2.0	3.0	mA	V <sub>DDD</sub> = 3.3 V, T <sub>A</sub> = 25 °C, all blocks except CPU are ON, CC I/O ON, no I/O sourcing current
<b>Deep Sleep Mode, V<sub>DDD</sub> = 2.7 to 3.6 V (Regulator on)</b>							
SID_DS_RA	I <sub>DD_DS_RA</sub>	V <sub>CONN1</sub> = 5.0, R <sub>A</sub> termination disabled	–	100	–	μA	V <sub>CONN1</sub> , V <sub>CONN2</sub> = 5 V, T <sub>A</sub> = 25 °C. R <sub>A</sub> termination disabled on V <sub>CONN1</sub> and V <sub>CONN2</sub> , see SID.PD.7. VCONN leaker circuits turned off during deep sleep
SID34	I <sub>DD29</sub>	V <sub>DDD</sub> = 2.7 to 3.6 V. I <sup>2</sup> C wakeup and WDT ON	–	50	–	μA	R <sub>A</sub> switch disabled on V <sub>CONN1</sub> and V <sub>CONN2</sub> . V <sub>DDD</sub> = 3.3 V, T <sub>A</sub> = 25 °C
SID_DS	I <sub>DD_DS</sub>	V <sub>DDD</sub> = 2.7 to 3.6 V. CC wakeup ON	–	2.5	–	μA	Power source = V <sub>DDD</sub> , Type-C not attached, CC enabled for wakeup, R <sub>p</sub> disabled
<b>XRES Current</b>							
SID307	I <sub>DD_XR</sub>	Supply current while XRES asserted	–	1	10	μA	–

**Table 3. AC Specifications**

Spec ID	Parameter	Description	Min	Typ	Max	Units	Details/Conditions
SID.CLK#4	F <sub>CPU</sub>	CPU frequency	DC	–	48	MHz	3.0 V ≤ V <sub>DD</sub> ≤ 5.5 V
SID.PWR#20	T <sub>SLEEP</sub>	Wakeup from sleep mode	–	0	–	μs	Guaranteed by characterization
SID.PWR#21	T <sub>DEEPSLEEP</sub>	Wakeup from Deep Sleep mode	–	–	35	μs	24-MHz IMO. Guaranteed by characterization
SID.XRES#5	T <sub>XRES</sub>	External reset pulse width	5	–	–	μs	Guaranteed by characterization
SYS.FES#1	T <sub>PWR_RDY</sub>	Power-up to “Ready to accept I2C / CC command”	–	5	25	ms	Guaranteed by characterization

I/O

**Table 4. I/O DC Specifications**

Spec ID	Parameter	Description	Min	Typ	Max	Units	Details/Conditions
SID.GIO#37	V <sub>IH</sub> <sup>[2]</sup>	Input voltage HIGH threshold	0.7 × V <sub>DDIO</sub>	–	–	V	CMOS input
SID.GIO#38	V <sub>IL</sub>	Input voltage LOW threshold	–	–	0.3 × V <sub>DDIO</sub>	V	CMOS input
SID.GIO#39	V <sub>IH</sub> <sup>[2]</sup>	LVTTL input, V <sub>DDIO</sub> < 2.7 V	0.7 × V <sub>DDIO</sub>	–	–	V	–
SID.GIO#40	V <sub>IL</sub>	LVTTL input, V <sub>DDIO</sub> < 2.7 V	–	–	0.3 × V <sub>DDIO</sub>	V	–
SID.GIO#41	V <sub>IH</sub> <sup>[2]</sup>	LVTTL input, V <sub>DDIO</sub> ≥ 2.7 V	2.0	–	–	V	–
SID.GIO#42	V <sub>IL</sub>	LVTTL input, V <sub>DDIO</sub> ≥ 2.7 V	–	–	0.8	V	–
SID.GIO#33	V <sub>OH</sub>	Output voltage HIGH level	V <sub>DDIO</sub> – 0.6	–	–	V	I <sub>OH</sub> = 4 mA at 3-V V <sub>DDIO</sub>
SID.GIO#34	V <sub>OH</sub>	Output voltage HIGH level	V <sub>DDIO</sub> – 0.5	–	–	V	I <sub>OH</sub> = 1 mA at 1.8-V V <sub>DDIO</sub>
SID.GIO#35	V <sub>OL</sub>	Output voltage LOW level	–	–	0.6	V	I <sub>OL</sub> = 4 mA at 1.8-V V <sub>DDIO</sub>
SID.GIO#36	V <sub>OL</sub>	Output voltage LOW level	–	–	0.6	V	I <sub>OL</sub> = 8 mA at 3 V V <sub>DDIO</sub>
SID.GIO#5	R <sub>PULLUP</sub>	Pull-up resistor	3.5	5.6	8.5	kΩ	–
SID.GIO#6	R <sub>PULLDOWN</sub>	Pull-down resistor	3.5	5.6	8.5	kΩ	–
SID.GIO#16	I <sub>IL</sub>	Input leakage current (absolute value)	–	–	2	nA	25 °C, V <sub>DDIO</sub> = 3.0 V. Guaranteed by characterization
SID.GIO#17	C <sub>IN</sub>	Input capacitance	–	–	7	pF	Guaranteed by characterization
SID.GIO#43	V <sub>HYSTTL</sub>	Input hysteresis LVTTL	25	40	–	mV	V <sub>DDIO</sub> ≥ 2.7 V. Guaranteed by characterization.
SID.GPIO#44	V <sub>HYSCMOS</sub>	Input hysteresis CMOS	0.05 × V <sub>DDIO</sub>	–	–	mV	Guaranteed by characterization
SID69	I <sub>DIODE</sub>	Current through protection diode to V <sub>DDIO</sub> /V <sub>SS</sub>	–	–	100	μA	Guaranteed by characterization
SID.GIO#45	I <sub>TOT_GPIO</sub>	Maximum total source or sink chip current	–	–	200	mA	Guaranteed by characterization

**Note**

- V<sub>IH</sub> must not exceed V<sub>DDIO</sub> + 0.2 V.

**Table 5. I/O AC Specifications**

(Guaranteed by Characterization)

Spec ID	Parameter	Description	Min	Typ	Max	Units	Details/Conditions
SID70	T <sub>RISEF</sub>	Rise time	2	–	12	ns	3.3-V V <sub>DDIO</sub> , Load = 25 pF
SID71	T <sub>FALLF</sub>	Fall time	2	–	12	ns	3.3-V V <sub>DDIO</sub> , Load = 25 pF

XRES

**Table 6. XRES DC Specifications**

Spec ID	Parameter	Description	Min	Typ	Max	Units	Details/Conditions
SID.XRES#1	V <sub>IH</sub>	Input voltage HIGH threshold	0.7 × V <sub>DDIO</sub>	–	–	V	CMOS input
SID.XRES#2	V <sub>IL</sub>	Input voltage LOW threshold	–	–	0.3 × V <sub>DDIO</sub>	V	CMOS input
SID.XRES#3	C <sub>IN</sub>	Input capacitance	–	–	7	pF	Guaranteed by characterization
SID.XRES#4	V <sub>HYSXRES</sub>	Input voltage hysteresis	–	–	0.05 × V <sub>DDIO</sub>	mV	Guaranteed by characterization

## Digital Peripherals

The following specifications apply to the Timer/Counter/PWM peripherals in the Timer mode.

*Pulse Width Modulation (PWM) for GPIO Pins*
**Table 7. PWM AC Specifications**

(Guaranteed by Characterization)

Spec ID	Parameter	Description	Min	Typ	Max	Units	Details/Conditions
SID.TCPWM.3	T <sub>CPWMFREQ</sub>	Operating frequency	–	F <sub>c</sub>	–	MHz	F <sub>c</sub> max = CLK_SYS. Maximum = 48 MHz.
SID.TCPWM.4	T <sub>PWMENEXT</sub>	Input trigger pulse width	–	2/F <sub>c</sub>	–	ns	For all Trigger Events
SID.TCPWM.5	T <sub>PWMEXT</sub>	Output trigger pulse width	–	2/F <sub>c</sub>	–	ns	Minimum possible width of Overflow, Underflow, and CC (Counter equals Compare value) outputs
SID.TCPWM.5A	T <sub>CRRES</sub>	Resolution of counter	–	1/F <sub>c</sub>	–	ns	Minimum time between successive counts
SID.TCPWM.5B	PWM <sub>RES</sub>	PWM resolution	–	1/F <sub>c</sub>	–	ns	Minimum pulse width of PWM output
SID.TCPWM.5C	Q <sub>RES</sub>	Quadrature inputs resolution	–	1/F <sub>c</sub>	–	ns	Minimum pulse width between quadrature-phase inputs

$I^2C$ 
**Table 8. Fixed I<sup>2</sup>C DC Specifications**

(Guaranteed by Characterization)

Spec ID	Parameter	Description	Min	Typ	Max	Units	Details/Conditions
SID149	I <sub>I2C1</sub>	Block current consumption at 100 kbps	–	–	60	μA	–
SID150	I <sub>I2C2</sub>	Block current consumption at 400 kbps	–	–	185	μA	–
SID151	I <sub>I2C3</sub>	Block current consumption at 1 Mbps	–	–	390	μA	–
SID152	I <sub>I2C4</sub>	I <sup>2</sup> C enabled in Deep Sleep mode	–	–	1.4	μA	–

**Table 9. Fixed I<sup>2</sup>C AC Specifications**

(Guaranteed by Characterization)

Spec ID	Parameter	Description	Min	Typ	Max	Units	Details/Conditions
SID153	F <sub>I2C1</sub>	Bit rate	–	–	1	Mbps	–

**Table 10. Fixed UART DC Specifications**

(Guaranteed by Characterization)

Spec ID	Parameter	Description	Min	Typ	Max	Units	Details/Conditions
SID160	I <sub>UART1</sub>	Block current consumption at 100 Kbps	–	–	125	μA	Guaranteed by characterization
SID161	I <sub>UART2</sub>	Block current consumption at 1000 Kbps	–	–	312	μA	Guaranteed by characterization

**Table 11. Fixed UART AC Specifications**

(Guaranteed by Characterization)

Spec ID	Parameter	Description	Min	Typ	Max	Units	Details/Conditions
SID162	F <sub>UART</sub>	Bit rate	–	–	1	Mbps	Guaranteed by characterization

**Table 12. Fixed SPI DC Specifications**

(Guaranteed by Characterization)

Spec ID	Parameter	Description	Min	Typ	Max	Units	Details/Conditions
SID163	I <sub>SPI1</sub>	Block current consumption at 1 Mbps	–	–	360	μA	Guaranteed by characterization
SID164	I <sub>SPI2</sub>	Block current consumption at 4 Mbps	–	–	560	μA	Guaranteed by characterization
SID165	I <sub>SPI3</sub>	Block current consumption at 8 Mbps	–	–	600	μA	Guaranteed by characterization

**Table 13. Fixed SPI AC Specifications**

(Guaranteed by Characterization)

Spec ID	Parameter	Description	Min	Typ	Max	Units	Details/Conditions
SID166	F <sub>SPI</sub>	SPI Operating frequency (Master; 6X oversampling)	–	–	8	MHz	Guaranteed by characterization

**Table 14. Fixed SPI Master Mode AC Specifications**

(Guaranteed by Characterization)

Spec ID	Parameter	Description	Min	Typ	Max	Units	Details/Conditions
SID167	T <sub>DMO</sub>	MOSI Valid after SClk driving edge	–	–	15	ns	Guaranteed by characterization
SID168	T <sub>DSI</sub>	MISO Valid before SClk capturing edge	20	–	–	ns	Full clock, late MISO sampling. Guaranteed by characterization
SID169	T <sub>HMO</sub>	Previous MOSI data hold time	0	–	–	ns	Referred to Slave capturing edge. Guaranteed by characterization

**Table 15. Fixed SPI Slave Mode AC Specifications**

(Guaranteed by Characterization)

Spec ID	Parameter	Description	Min	Typ	Max	Units	Details/Conditions
SID170	T <sub>DMI</sub>	MOSI Valid before SClk Capturing edge	40	–	–	ns	Guaranteed by characterization
SID171	T <sub>DSO</sub>	MISO Valid after SClk driving edge	–	–	42 + 3 * T <sub>CPU</sub>	ns	T <sub>CPU</sub> = 1/FCPU. Guaranteed by characterization.
SID171A	T <sub>DSO_EXT</sub>	MISO Valid after SClk driving edge in Ext Clk mode	–	–	48	ns	Guaranteed by characterization
SID172	T <sub>HSO</sub>	Previous MISO data hold time	0	–	–	ns	Guaranteed by characterization
SID172A	T <sub>SSELSCK</sub>	SSEL Valid to first SCK Valid edge	100	–	–	ns	Guaranteed by characterization

## Memory

**Table 16. Flash AC Specifications**

Spec ID	Parameter	Description	Min	Typ	Max	Units	Details/Conditions
SID.MEM#4	T <sub>ROWWRITE</sub> <sup>[3]</sup>	Row (block) write time (erase and program)	–	–	20	ms	Row (block) = 128 bytes
SID.MEM#3	T <sub>ROWERASE</sub> <sup>[3]</sup>	Row erase time	–	–	13	ms	–
SID.MEM#8	T <sub>ROWPROGRAM</sub> <sup>[3]</sup>	Row program time after erase	–	–	7	ms	–
SID178	T <sub>BULKERASE</sub> <sup>[3]</sup>	Bulk erase time (32 KB)	–	–	35	ms	–
SID180	T <sub>DEVPROG</sub> <sup>[3]</sup>	Total device program time	–	–	7.5	seconds	Guaranteed by characterization
SID181	F <sub>END</sub>	Flash endurance	100 K	–	–	cycles	Guaranteed by characterization
SID182	F <sub>RET1</sub>	Flash retention. T <sub>A</sub> ≤ 55 °C, 100 K P/E cycles	20	–	–	years	Guaranteed by characterization
SID182A	F <sub>RET2</sub>	Flash retention. T <sub>A</sub> ≤ 85 °C, 10 K P/E cycles	10	–	–	years	Guaranteed by characterization

**Note**

- It can take as much as 20 milliseconds to write to Flash. During this time the device should not be Reset, or Flash operations will be interrupted and cannot be relied on to have completed. Reset sources include the XRES pin, software resets, CPU lockup states and privilege violations, improper power supply levels, and watchdogs. Make certain that these are not inadvertently activated.

**System Resources**
*Power-on-Reset (POR) with Brown Out*
**Table 17. Imprecise Power On Reset (PRES)**

Spec ID	Parameter	Description	Min	Typ	Max	Units	Details/Conditions
SID185	V <sub>RISEIPOR</sub>	Rising trip voltage	0.80	–	1.50	V	Guaranteed by characterization
SID186	V <sub>FALLIPOR</sub>	Falling trip voltage	0.75	–	1.4	V	Guaranteed by characterization

**Table 18. Precise Power On Reset (POR)**

Spec ID	Parameter	Description	Min	Typ	Max	Units	Details/Conditions
SID190	V <sub>FALLPPOR</sub>	BOD trip voltage in active and sleep modes	1.48	–	1.62	V	Guaranteed by characterization
SID192	V <sub>FALLDPSLP</sub>	BOD trip voltage in Deep Sleep	1.1	–	1.5	V	Guaranteed by characterization

*SWD Interface*
**Table 19. SWD Interface Specifications**

Spec ID	Parameter	Description	Min	Typ	Max	Units	Details/Conditions
SID.SWD#1	F_SWDCCLK1	$3.3\text{ V} \leq V_{DDIO} \leq 5.5\text{ V}$	–	–	14	MHz	SWDCCLK $\leq$ 1/3 CPU clock frequency
SID.SWD#2	F_SWDCCLK2	$1.8\text{ V} \leq V_{DDIO} \leq 3.3\text{ V}$	–	–	7	MHz	SWDCCLK $\leq$ 1/3 CPU clock frequency
SID.SWD#3	T_SWDI_SETUP	$T = 1/f\text{ SWDCCLK}$	0.25*T	–	–	ns	Guaranteed by characterization
SID.SWD#4	T_SWDI_HOLD	$T = 1/f\text{ SWDCCLK}$	0.25*T	–	–	ns	Guaranteed by characterization
SID.SWD#5	T_SWDO_VALID	$T = 1/f\text{ SWDCCLK}$	–	–	0.5 * T	ns	Guaranteed by characterization
SID.SWD#6	T_SWDO_HOLD	$T = 1/f\text{ SWDCCLK}$	1	–	–	ns	Guaranteed by characterization

*Internal Main Oscillator*
**Table 20. IMO DC Specifications**
*(Guaranteed by Design)*

Spec ID	Parameter	Description	Min	Typ	Max	Units	Details/Conditions
SID218	I <sub>IMO</sub>	IMO operating current at 48 MHz	–	–	1000	μA	–

**Table 21. IMO AC Specifications**

Spec ID	Parameter	Description	Min	Typ	Max	Units	Details/Conditions
SID.CLK#13	F <sub>IMOTOL</sub>	Frequency variation at 24, 36, and 48 MHz (trimmed)	–	–	±2	%	–
SID226	T <sub>STARTIMO</sub>	IMO startup time	–	–	7	μs	Guaranteed by characterization
SID229	T <sub>JITRMSIMO</sub>	RMS jitter at 48 MHz	–	145	–	ps	Guaranteed by characterization
F <sub>IMO</sub>	–	IMO frequency	24	–	48	MHz	–

*Internal Low-Speed Oscillator*
**Table 22. ILO DC Specifications**

(Guaranteed by Design)

Spec ID	Parameter	Description	Min	Typ	Max	Units	Details/Conditions
SID231	I <sub>ILO</sub>	ILO operating current at 32 kHz	–	0.3	1.05	μA	Guaranteed by Characterization
SID233	I <sub>ILOLEAK</sub>	ILO leakage current	–	2	15	nA	Guaranteed by Design

**Table 23. ILO AC Specifications**

Spec ID	Parameter	Description	Min	Typ	Max	Units	Details/Conditions
SID234	T <sub>STARTILO</sub>	ILO startup time	–	–	2	ms	Guaranteed by characterization
SID236	T <sub>ILODUTY</sub>	ILO duty cycle	40	50	60	%	Guaranteed by characterization
SID.CLK#5	F <sub>ILO</sub>	ILO Frequency	20	40	80	kHz	–

*Power Down*
**Table 24. PD DC Specifications**

Spec ID	Parameter	Description	Min	Typ	Max	Units	Details/Conditions
SID.PD.1	R <sub>p_std</sub>	DFP CC termination for default USB Power	64	80	96	μA	–
SID.PD.2	R <sub>p_1.5A</sub>	DFP CC termination for 1.5A power	166	180	194	μA	–
SID.PD.3	R <sub>p_3.0A</sub>	DFP CC termination for 3.0A power	304	330	356	μA	–
SID.PD.4	R <sub>d</sub>	UFP CC termination	4.59	5.1	5.61	kΩ	–
SID.PD.5	R <sub>d_DB</sub>	UFP Dead Battery CC termination on RD1 and CC2	4.08	5.1	6.12	kΩ	All supplies forced to 0 V and 0.6 V applied at RD1 or CC2
SID.PD.6	R <sub>A</sub>	Power cable termination	0.8	1.0	1.2	kΩ	All supplies forced to 0 V and 0.2 V applied at V <sub>CONN1</sub> or V <sub>CONN2</sub>
SID.PD.7	R <sub>a_OFF</sub>	Power cable termination - Disabled	0.4	0.75	–	MΩ	2.7 V applied at V <sub>CONN1</sub> or V <sub>CONN2</sub> with R <sub>A</sub> disabled
SID.PD.8	R <sub>leak_1</sub>	V <sub>CONN</sub> leaker for 0.1-μF load	–	–	216	kΩ	Managed Active Cable (MAC) discharge
SID.PD.9	R <sub>leak_2</sub>	V <sub>CONN</sub> leaker for 0.5-μF load	–	–	41.2	kΩ	
SID.PD.10	R <sub>leak_3</sub>	V <sub>CONN</sub> leaker for 1.0-μF load	–	–	19.6	kΩ	
SID.PD.11	R <sub>leak_4</sub>	V <sub>CONN</sub> leaker for 2.0-μF load	–	–	9.8	kΩ	
SID.PD.12	R <sub>leak_5</sub>	V <sub>CONN</sub> leaker for 5.0-μF load	–	–	4.1	kΩ	
SID.PD.13	R <sub>leak_6</sub>	V <sub>CONN</sub> leaker for 10-μF load	–	–	2.0	kΩ	
SID.PD.14	I <sub>leak</sub>	Leaker on V <sub>CONN1</sub> and V <sub>CONN2</sub> for discharge upon cable detach	150	–	–	μA	–

*Analog-to-Digital Converter*
**Table 25. ADC DC Specifications**

Spec ID	Parameter	Description	Min	Typ	Max	Units	Details/Conditions
SID.ADC.1	Resolution	ADC resolution	–	8	–	bits	Guaranteed by characterization
SID.ADC.2	INL	Integral non-linearity	–1.5	–	1.5	LSB	Guaranteed by characterization
SID.ADC.3	DNL	Differential non-linearity	–2.5	–	2.5	LSB	Guaranteed by characterization
SID.ADC.4	Gain Error	Gain error	–1	–	1	LSB	Guaranteed by characterization

**Table 26. ADC AC Specifications**

Spec ID	Parameter	Description	Min	Typ	Max	Units	Details/Conditions
SID.ADC.5	SLEW_Max	Rate of change of sampled voltage signal	–	–	3	V/ms	Guaranteed by characterization

## Ordering Information

The EZ-PD CCG2 part numbers and features are listed in [Table 27](#).

**Table 27. EZ-PD CCG2 Ordering Information**

Part Number	Application	Type-C Ports	Termination Resistor	Role	Package
CYPD2103-20FNXIT	Cable	1	R <sub>A</sub> <sup>[4]</sup>	Cable	20-ball CSP
CYPD2103-14LHXIT	Cable	1	R <sub>A</sub> <sup>[4]</sup>	Cable	14-pin DFN
CYPD2104-20FNXIT	Accessory	1	R <sub>D</sub> <sup>[5]</sup>	Accessory	20-ball CSP
CYPD2105-20FNXIT	Active Cable	1	R <sub>A</sub> <sup>[4]</sup>	Active Cable	20-ball CSP
CYPD2119-24LQXIT	C-DP	1	R <sub>D</sub> <sup>[5]</sup>	UFP	24-pin QFN
CYPD2120-24LQXIT	C-HDMI	1	R <sub>D</sub> <sup>[5]</sup>	UFP	24-pin QFN
CYPD2121-24LQXIT	Dock/Monitor Upstream port	1	R <sub>P</sub> <sup>[6]</sup> , R <sub>D</sub> <sup>[5]</sup>	DRP	24-pin QFN
CYPD2122-20FNXIT	Tablet	1	R <sub>P</sub> <sup>[6]</sup> , R <sub>D</sub> <sup>[5]</sup>	DRP	20-ball CSP
CYPD2122-24LQXI	Notebook	1	R <sub>P</sub> <sup>[6]</sup> , R <sub>D</sub> <sup>[5]</sup>	DRP	24-pin QFN
CYPD2122-24LQXIT	Notebook	1	R <sub>P</sub> <sup>[6]</sup> , R <sub>D</sub> <sup>[5]</sup>	DRP	24-pin QFN
CYPD2125-24LQXIT	Dock/Monitor Downstream port	1	R <sub>P</sub> <sup>[6]</sup>	DFP	24-pin QFN
CYPD2134-24LQXIT	DFP	1	R <sub>P</sub> <sup>[6]</sup>	DFP	24-pin QFN
CYPD2134-24LQXQT	DFP	1	R <sub>P</sub> <sup>[6]</sup>	DFP	24-pin QFN

## Ordering Code Definitions

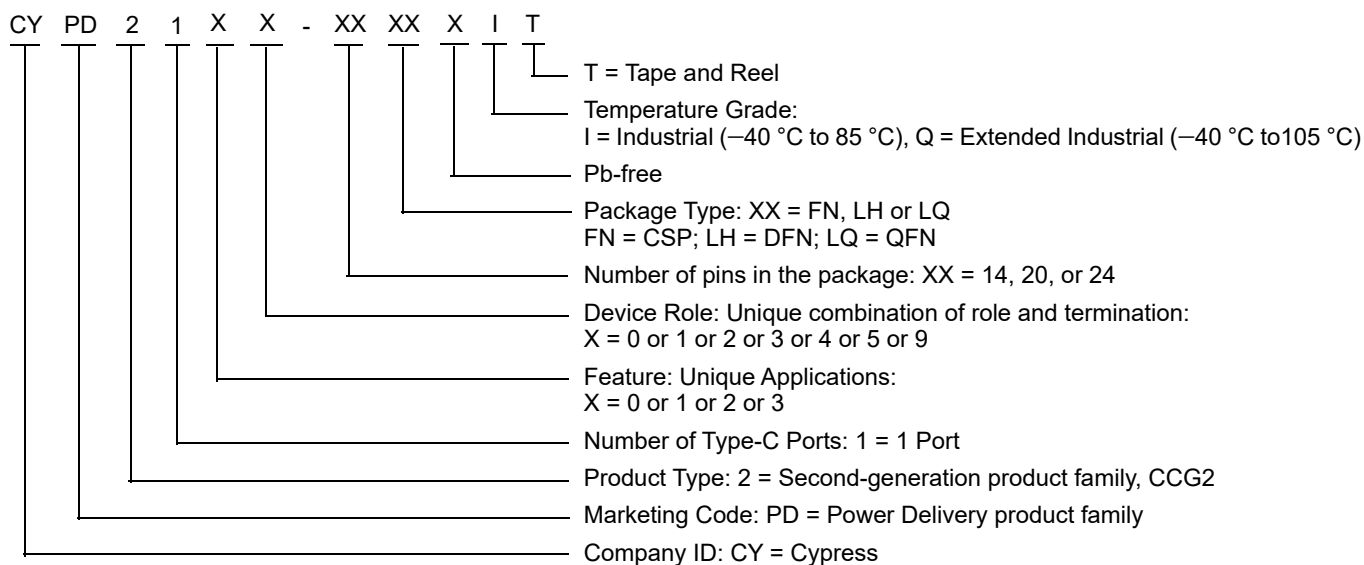

### Notes

4. Termination resistor denoting an EMCA.
5. Termination resistor denoting an accessory or upstream facing port.
6. Termination resistor denoting a downstream facing port.

## Packaging

**Table 28. Package Characteristics**

Parameter	Description	Conditions	Min	Typ	Max	Units
T <sub>A</sub>	Operating ambient temperature	Industrial	-40	25	85	°C
		Extended Industrial			105	°C
T <sub>J</sub>	Operating junction temperature	Industrial	-40	-	100	°C
		Extended Industrial			125	°C
T <sub>JA</sub>	Package $\theta_{JA}$ (20-ball WLCSP)	-	-	66	-	°C/W
T <sub>JC</sub>	Package $\theta_{JC}$ (20-ball WLCSP)	-	-	0.7	-	°C/W
T <sub>JA</sub>	Package $\theta_{JA}$ (14-pin DFN)	-	-	31	-	°C/W
T <sub>JC</sub>	Package $\theta_{JC}$ (14-pin DFN)	-	-	59	-	°C/W
T <sub>JA</sub>	Package $\theta_{JA}$ (24-pin QFN)	-	-	22	-	°C/W
T <sub>JC</sub>	Package $\theta_{JC}$ (24-pin QFN)	-	-	29	-	°C/W

**Table 29. Solder Reflow Peak Temperature**

Package	Maximum Peak Temperature	Maximum Time within 5 °C of Peak Temperature
20-ball WLCSP	260 °C	30 seconds
14-pin DFN	260 °C	30 seconds
24-pin QFN	260 °C	30 seconds

**Table 30. Package Moisture Sensitivity Level (MSL), IPC/JEDEC J-STD-2**

Package	MSL
20-ball WLCSP	MSL 1
14-pin DFN	MSL 3
24-pin QFN	MSL 3

**Figure 17. 20-ball WLCSP (1.63 × 2.03 × 0.55 mm) FN20B Package Outline, 001-95010**

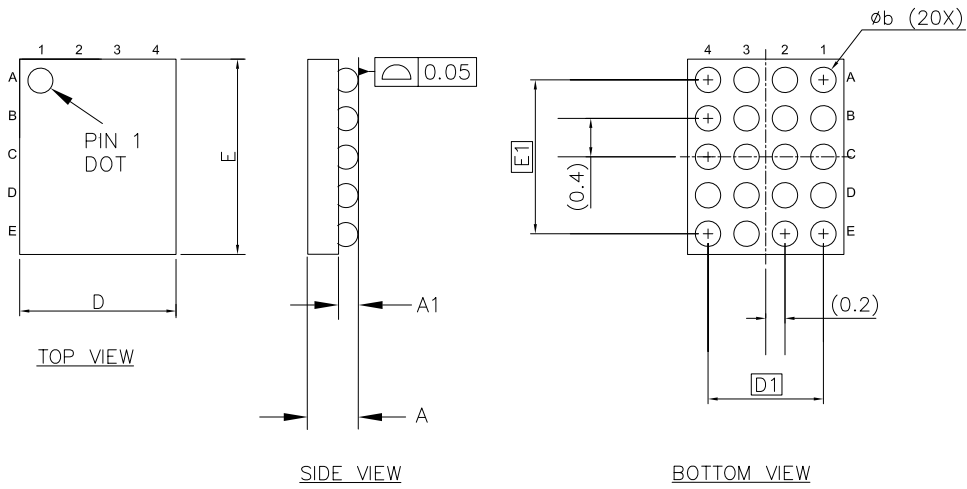

SYMBOL	DIMENSIONS		
	MIN.	NOM.	MAX.
A	—	—	0.55
A1	0.18	0.21	0.24
D	1.605	1.63	1.655
E	2.005	2.03	2.055
D1	1.2 BSC		
E1	1.6 BSC		
n	20		
Øb	0.23	0.26	0.29

**NOTES**

1. ALL DIMENSIONS ARE IN MILLIMETERS.
2. REFERENCE JEDEC PUBLICATION 95, DESIGN GUIDE 4.18

001-95010 \*B

**Figure 18. 14-pin DFN (2.5 × 3.5 × 0.6 mm), LH14A, 0.95 × 3.00 E-Pad (Sawn) Package Outline, 001-96312**

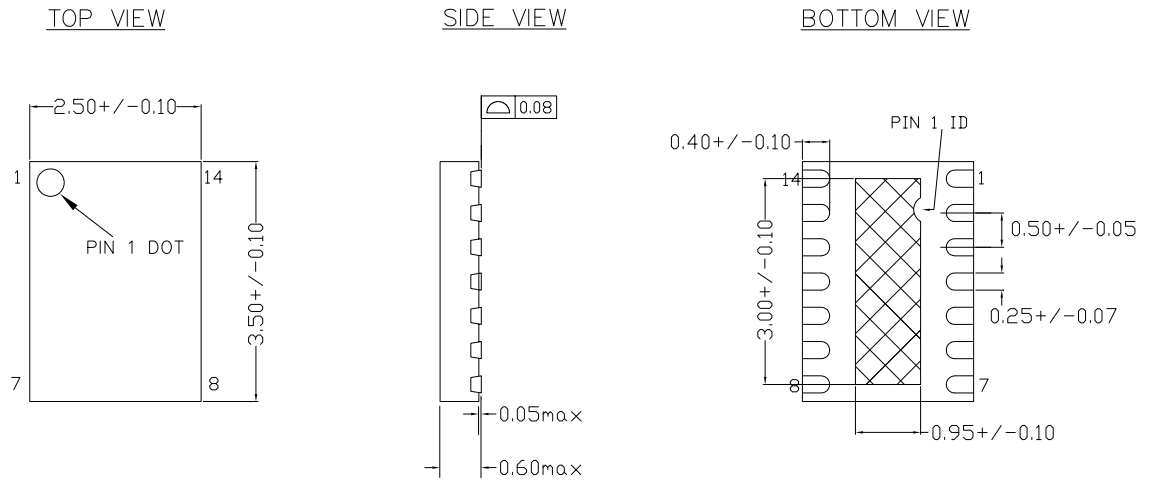

**NOTES :**

1. HATCH AREA IS SOLDERABLE EXPOSED METAL
2. ALL DIMENSIONS ARE IN MILLIMETERS

001-96312 \*\*

**Figure 19. 24-Pin QFN (4 × 4 × 0.55 mm), LQ24A, 2.65 × 2.65 E-Pad (Sawn) Package Outline, 001-13937**

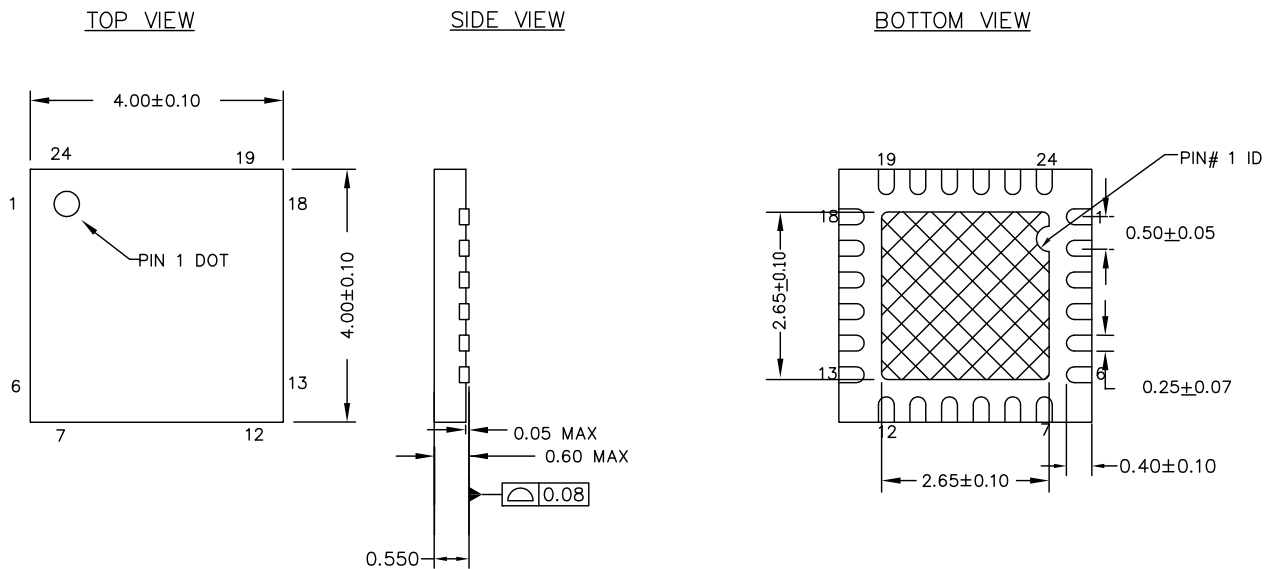

**NOTES :**

1. HATCH IS SOLDERABLE EXPOSED METAL.
2. REFERENCE JEDEC # MO-248
3. PACKAGE WEIGHT : 29 ± 3 mg
4. ALL DIMENSIONS ARE IN MILLIMETERS

001-13937 \*G

## Acronyms

**Table 31. Acronyms Used in this Document**

Acronym	Description
ADC	analog-to-digital converter
API	application programming interface
ARM®	advanced RISC machine, a CPU architecture
CC	configuration channel
CCG2	Cable Controller Generation 2
CPU	central processing unit
CRC	cyclic redundancy check, an error-checking protocol
CS	current sense
DFP	downstream facing port
DIO	digital input/output, GPIO with only digital capabilities, no analog. See GPIO.
DRP	dual role port
EEPROM	electrically erasable programmable read-only memory
EMCA	a USB cable that includes an IC that reports cable characteristics (e.g., current rating) to the Type-C ports
EMI	electromagnetic interference
ESD	electrostatic discharge
FPB	flash patch and breakpoint
FS	full-speed
GPIO	general-purpose input/output
IC	integrated circuit
IDE	integrated development environment
I <sup>2</sup> C, or IIC	Inter-Integrated Circuit, a communications protocol
ILO	internal low-speed oscillator, see also IMO
IMO	internal main oscillator, see also ILO
I/O	input/output, see also GPIO
LVD	low-voltage detect
LVTTTL	low-voltage transistor-transistor logic
MCU	microcontroller unit
NC	no connect
NMI	nonmaskable interrupt

**Table 31. Acronyms Used in this Document (continued)**

Acronym	Description
NVIC	nested vectored interrupt controller
opamp	operational amplifier
OCP	overcurrent protection
OVP	overvoltage protection
PCB	printed circuit board
PD	power delivery
PGA	programmable gain amplifier
PHY	physical layer
POR	power-on reset
PRES	precise power-on reset
PSoC®	Programmable System-on-Chip™
PWM	pulse-width modulator
RAM	random-access memory
RISC	reduced-instruction-set computing
RMS	root-mean-square
RTC	real-time clock
RX	receive
SAR	successive approximation register
SCL	I <sup>2</sup> C serial clock
SDA	I <sup>2</sup> C serial data
S/H	sample and hold
SPI	Serial Peripheral Interface, a communications protocol
SRAM	static random access memory
SWD	serial wire debug, a test protocol
TX	transmit
Type-C	a new standard with a slimmer USB connector and a reversible cable, capable of sourcing up to 100 W of power
UART	Universal Asynchronous Transmitter Receiver, a communications protocol
USB	Universal Serial Bus
USBIO	USB input/output, CCG2 pins used to connect to a USB port
XRES	external reset I/O pin

## Document Conventions

### Units of Measure

**Table 32. Units of Measure**

Symbol	Unit of Measure
°C	degrees Celsius
Hz	hertz
KB	1024 bytes
kHz	kilohertz
kΩ	kilo ohm
Mbps	megabits per second
MHz	megahertz
MΩ	mega-ohm
Msps	megasamples per second
μA	microampere
μF	microfarad
μs	microsecond

**Table 32. Units of Measure (continued)**

Symbol	Unit of Measure
μV	microvolt
μW	microwatt
mA	milliampere
ms	millisecond
mV	millivolt
nA	nanoampere
ns	nanosecond
Ω	ohm
pF	picofarad
ppm	parts per million
ps	picosecond
s	second
sps	samples per second
V	volt

## References and Links To Applications Collaterals

### Knowledge Base Articles

- Key Differences Among EZ-PD™ CCG1, CCG2, CCG3 and CCG4 - KBA210740
- Programming EZ-PD™ CCG2, EZ-PD™ CCG3 and EZ-PD™ CCG4 Using PSoC® Programmer and MiniProg3 - KBA96477
- CCGX Frequently Asked Questions (FAQs) - KBA97244
- Handling Precautions for CY4501 CCG1 DVK - KBA210560
- Cypress EZ-PD™ CCGx Hardware - KBA204102
- Difference between USB Type-C and USB-PD - KBA204033
- CCGx Programming Methods - KBA97271
- Getting started with Cypress USB Type-C Products - KBA04071
- Type-C to DisplayPort Cable Electrical Requirements
- Dead Battery Charging Implementation in USB Type-C Solutions - KBA97273
- Termination Resistors Required for the USB Type-C Connector – KBA97180
- VBUS Bypass Capacitor Recommendation for Type-C Cable and Type-C to Legacy Cable/Adapter Assemblies – KBA97270
- Need for Regulator and Auxiliary Switch in Type-C to DisplayPort (DP) Cable Solution - KBA97274
- Need for a USB Billboard Device in Type-C Solutions – KBA97146
- CCG1 Devices in Type-C to Legacy Cable/Adapter Assemblies – KBA97145
- Cypress USB Type-C Controller Supported Solutions – KBA97179
- Termination Resistors for Type-C to Legacy Ports – KBA97272
- Handling Instructions for CY4502 CCG2 Development Kit – KBA97916
- Thunderbolt™ Cable Application Using CCG3 Devices - KBA210976
- Power Adapter Application Using CCG3 Devices - KBA210975
- Methods to Upgrade Firmware on CCG3 Devices - KBA210974
- Device Flash Memory Size and Advantages - KBA210973
- Applications of EZ-PD™ CCG4 - KBA210739

### Application Notes

- AN96527 - Designing USB Type-C Products Using Cypress's CCG1 Controllers

- AN95615 - Designing USB 3.1 Type-C Cables Using EZ-PD™ CCG2
- AN95599 - Hardware Design Guidelines for EZ-PD™ CCG2
- AN210403 - Hardware Design Guidelines for Dual Role Port Applications Using EZ-PD™ USB Type-C Controllers
- AN210771 - Getting Started with EZ-PD™ CCG4

### Reference Designs

- EZ-PD™ CCG2 Electronically Marked Cable Assembly (EMCA) Paddle Card Reference Design
- EZ-PD™ CCG2 USB Type-C to DisplayPort Cable Solution
- CCG1 USB Type-C to DisplayPort Cable Solution
- CCG1 USB Type-C to HDMI/DVI/VGA Adapter Solution
- EZ-PD™ CCG2 USB Type-C to HDMI Adapter Solution
- CCG1 Electronically Marked Cable Assembly (EMCA) Paddle Card Reference Design
- CCG1 USB Type-C to Legacy USB Device Cable Paddle Card Reference Schematics
- EZ-USB GX3 USB Type-C to Gigabit Ethernet Dongle
- EZ-PD™ CCG2 USB Type-C Monitor/Dock Solution
- CCG2 20W Power Adapter Reference Design
- CCG2 18W Power Adapter Reference Design
- EZ-USB GX3 USB Type-A to Gigabit Ethernet Reference Design Kit

### Kits

- CY4501 CCG1 Development Kit
- CY4502 EZ-PD™ CCG2 Development Kit
- CY4531 EZ-PD CCG3 Evaluation Kit
- CY4541 EZ-PD™ CCG4 Evaluation Kit

### Datasheets

- CCG1 Datasheet: USB Type-C Port Controller with Power Delivery
- CYPD1120 Datasheet: USB Power Delivery Alternate Mode Controller on Type-C
- CCG3: USB Type-C Controller Datasheet
- CCG4: Two-Port USB Type-C Controller Datasheet

**Document History Page**

Description Title: EZ-PD™ CCG2 Datasheet USB Type-C Port Controller				
Document Number: 001-93912				
Revision	ECN	Orig. of Change	Submission Date	Description of Change
*E	4680071	GAYA	03/07/2015	Release to web
*F	4718374	AKN	04/09/2015	Added 24-pin QFN pin and package information. Added DRP and DFP Application diagrams
*G	4774142	AKN	06/15/2015	Changed datasheet status from Preliminary to Final. Updated Logic Block Diagram. Changed number of GPIOs to 10 and added a note about the number of GPIOs varying depending on the package. Updated Power and Digital Peripherals section. Updated Application diagrams. Added SID.PWR#1_A parameter. Added CYPD2122-20FNXIT part in Ordering Information. Removed Errata.
*H	4979175	VGT	10/23/2015	Updated Figure 1 and Figure 5. Added VCC_ABS spec and updated the SID.ADC.4 parameter. Added "Guaranteed by characterization" note for the following specs: SID.GIO#16, SID.GIO#17, SID.XRES#3, SID 160 to SID 172A, SID 2226, SID 229, SID.ADC.1 to SID.ADC.5.
*I	5028128	VGT	12/04/2015	Updated <a href="#">Application Diagrams</a> : Added <a href="#">Figure 14</a> . Added <a href="#">Figure 15</a> . Added <a href="#">Figure 16</a> . Updated <a href="#">Ordering Information</a> . Added part numbers CYPD2119-24LQXIT, CYPD2120-24LQXIT, CYPD2121-24LQXIT, CYPD2125-24LQXIT.
*J	5186972	VGT	03/28/2016	Updated temperature ranges in <a href="#">Features</a> . Updated <a href="#">Table 28</a> . Updated <a href="#">Ordering Information</a> .
*K	5303957	VGT	06/13/2016	Added <a href="#">Available Firmware and Software Tools</a> . Updated <a href="#">Figure 8</a> : Per the USB PD3.0 spec, SOP" implementation is no longer valid for passive cables. Updated <a href="#">Figure 11</a> , <a href="#">Figure 12</a> , and <a href="#">Figure 13</a> . Added descriptive notes for the application diagrams. Added <a href="#">References and Links To Applications Collaterals</a> . Updated <a href="#">Ordering Information</a> . Updated Cypress logo and copyright information.
*L	5387677	VGT	08/02/2016	Added CYPD2122-24LQXI part number in <a href="#">Ordering Information</a> .
*M	6097993	VGT	07/11/2018	Added <a href="#">Figure 8</a> and <a href="#">Figure 10</a> . Updated the title of <a href="#">Figure 7</a> and <a href="#">Figure 9</a> . Added "Note: Application diagram in Figure 8 requires external diodes to operate in the extended VCONN voltage range of 2.7V to 5.5V" in <a href="#">Application Diagrams</a> . Updated <a href="#">Figure 17</a> (Spec 001-95010 from *A to *B). Updated <a href="#">Figure 19</a> (Spec 001-13937 from *F to *G). Added compliance to USB Specification. Updated Cypress Logo and Copyright year.

## Sales, Solutions, and Legal Information

### Worldwide Sales and Design Support

Cypress maintains a worldwide network of offices, solution centers, manufacturer's representatives, and distributors. To find the office closest to you, visit us at [Cypress Locations](#).

#### Products

Arm® Cortex® Microcontrollers	<a href="http://cypress.com/arm">cypress.com/arm</a>
Automotive	<a href="http://cypress.com/automotive">cypress.com/automotive</a>
Clocks & Buffers	<a href="http://cypress.com/clocks">cypress.com/clocks</a>
Interface	<a href="http://cypress.com/interface">cypress.com/interface</a>
Internet of Things	<a href="http://cypress.com/iot">cypress.com/iot</a>
Memory	<a href="http://cypress.com/memory">cypress.com/memory</a>
Microcontrollers	<a href="http://cypress.com/mcu">cypress.com/mcu</a>
PSoC	<a href="http://cypress.com/psoc">cypress.com/psoc</a>
Power Management ICs	<a href="http://cypress.com/pmic">cypress.com/pmic</a>
Touch Sensing	<a href="http://cypress.com/touch">cypress.com/touch</a>
USB Controllers	<a href="http://cypress.com/usb">cypress.com/usb</a>
Wireless Connectivity	<a href="http://cypress.com/wireless">cypress.com/wireless</a>

#### PSoC® Solutions

[PSoC 1](#) | [PSoC 3](#) | [PSoC 4](#) | [PSoC 5LP](#) | [PSoC 6 MCU](#)

#### Cypress Developer Community

[Forums](#) | [WICED IOT Forums](#) | [Projects](#) | [Video](#) | [Blogs](#) | [Training](#) | [Components](#)

#### Technical Support

[cypress.com/support](http://cypress.com/support)

Notice regarding compliance with Universal Serial Bus specification. Cypress offers firmware and hardware solutions that are certified to comply with the Universal Serial Bus specification, USB Type-C™ Cable and Connector Specification, and other specifications of USB Implementers Forum, Inc (USB-IF). You may use Cypress or third party software tools, including sample code, to modify the firmware for Cypress USB products. Modification of such firmware could cause the firmware/hardware combination to no longer comply with the relevant USB-IF specification. You are solely responsible ensuring the compliance of any modifications you make, and you must follow the compliance requirements of USB-IF before using any USB-IF trademarks or logos in connection with any modifications you make. In addition, if Cypress modifies firmware based on your specifications, then you are responsible for ensuring compliance with any desired standard or specifications as if you had made the modification. CYPRESS IS NOT RESPONSIBLE IN THE EVENT THAT YOU MODIFY OR HAVE MODIFIED A CERTIFIED CYPRESS PRODUCT AND SUCH MODIFIED PRODUCT NO LONGER COMPLIES WITH THE RELEVANT USB-IF SPECIFICATIONS.



© Cypress Semiconductor Corporation 2014-2018 This document is the property of Cypress Semiconductor Corporation and its subsidiaries, including Spansion LLC ("Cypress"). This document, including any software or firmware included or referenced in this document ("Software"), is owned by Cypress under the intellectual property laws and treaties of the United States and other countries worldwide. Cypress reserves all rights under such laws and treaties and does not, except as specifically stated in this paragraph, grant any license under its patents, copyrights, trademarks, or other intellectual property rights. If the Software is not accompanied by a license agreement and you do not otherwise have a written agreement with Cypress governing the use of the Software, then Cypress hereby grants you a personal, non-exclusive, nontransferable license (without the right to sublicense) (1) under its copyright rights in the Software (a) for Software provided in source code form, to modify and reproduce the Software solely for use with Cypress hardware products, only internally within your organization, and (b) to distribute the Software in binary code form externally to end users (either directly or indirectly through resellers and distributors), solely for use on Cypress hardware product units, and (2) under those claims of Cypress's patents that are infringed by the Software (as provided by Cypress, unmodified) to make, use, distribute, and import the Software solely for use with Cypress hardware products. Any other use, reproduction, modification, translation, or compilation of the Software is prohibited.

TO THE EXTENT PERMITTED BY APPLICABLE LAW, CYPRESS MAKES NO WARRANTY OF ANY KIND, EXPRESS OR IMPLIED, WITH REGARD TO THIS DOCUMENT OR ANY SOFTWARE OR ACCOMPANYING HARDWARE, INCLUDING, BUT NOT LIMITED TO, THE IMPLIED WARRANTIES OF MERCHANTABILITY AND FITNESS FOR A PARTICULAR PURPOSE. No computing device can be absolutely secure. Therefore, despite security measures implemented in Cypress hardware or software products, Cypress does not assume any liability arising out of any security breach, such as unauthorized access to or use of a Cypress product. In addition, the products described in these materials may contain design defects or errors known as errata which may cause the product to deviate from published specifications. To the extent permitted by applicable law, Cypress reserves the right to make changes to this document without further notice. Cypress does not assume any liability arising out of the application or use of any product or circuit described in this document. Any information provided in this document, including any sample design information or programming code, is provided only for reference purposes. It is the responsibility of the user of this document to properly design, program, and test the functionality and safety of any application made of this information and any resulting product. Cypress products are not designed, intended, or authorized for use as critical components in systems designed or intended for the operation of weapons, weapons systems, nuclear installations, life-support devices or systems, other medical devices or systems (including resuscitation equipment and surgical implants), pollution control or hazardous substances management, or other uses where the failure of the device or system could cause personal injury, death, or property damage ("Unintended Uses"). A critical component is any component of a device or system whose failure to perform can be reasonably expected to cause the failure of the device or system, or to affect its safety or effectiveness. Cypress is not liable, in whole or in part, and you shall and hereby do release Cypress from any claim, damage, or other liability arising from or related to all Unintended Uses of Cypress products. You shall indemnify and hold Cypress harmless from and against all claims, costs, damages, and other liabilities, including claims for personal injury or death, arising from or related to any Unintended Uses of Cypress products.

Cypress, the Cypress logo, Spansion, the Spansion logo, and combinations thereof, PSoC, CapSense, EZ-USB, F-RAM, and Traveo are trademarks or registered trademarks of Cypress in the United States and other countries. For a more complete list of Cypress trademarks, visit [cypress.com](http://cypress.com). Other names and brands may be claimed as property of their respective owners.

## Looking for pricing, stock, or lifecycle information?

Click below to explore more details on WIN SOURCE:

-  [View CYPD2104-20FNXIT on WIN SOURCE](#)
-  [Cypress Semiconductor Corp Information](#)

## Optimize Your Supply Chain with WIN SOURCE Solutions

-  Global Sourcing Solution
-  Obsolete Management
-  Cost Control Management
-  Shortage Management
-  Alternative Solution
-  Excess Inventory Management