



**THE DATASHEET OF  
CY7C199C-25PC**



**256K (32K x 8) Static RAM**
**Features**

- **Fast access time: 12 ns, 15 ns, 20 ns, and 25 ns**
- **Wide voltage range: 5.0V ± 10% (4.5V to 5.5V)**
- **CMOS for optimum speed/power**
- **TTL-compatible Inputs and Outputs**
- **Available in 28 DIP, 28 SOJ, and 28 TSOP I packages**
- **Also available in Lead-Free 28 DIP**
- **2.0V Data Retention**
- **Low CMOS standby power**
- **Automated Power-down when deselected**

**General Description**

The CY7C199C is a high-performance CMOS Asynchronous SRAM organized as 32K by 8 bits that supports an asynchronous memory interface. The device features an automatic power-down feature that significantly reduces power consumption when deselected.

See the Truth Table in this data sheet for a complete description of read and write modes.

The CY7C199C is available in 28 DIP, 28 SOJ, and 28 TSOP I package(s).

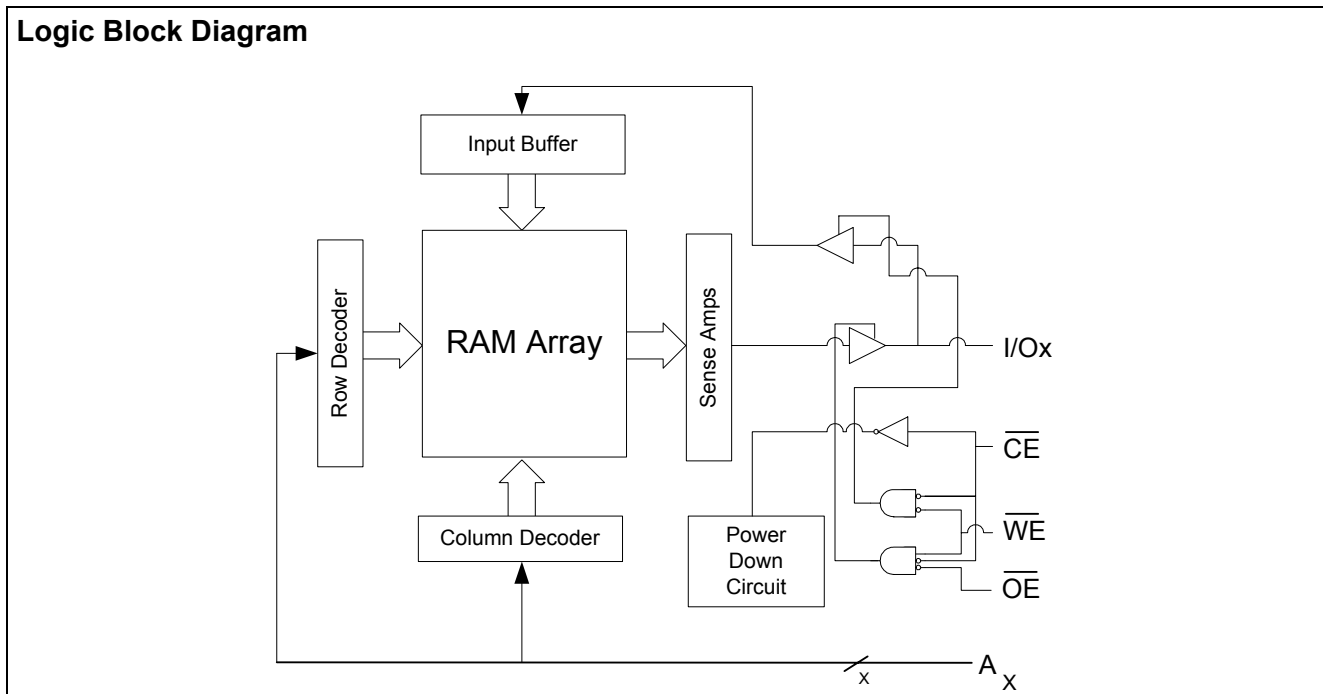
**Logic Block Diagram**

**Product Portfolio**

	<b>12 ns</b>	<b>15 ns</b>	<b>20 ns</b>	<b>25 ns</b>	<b>Unit</b>
Maximum Access Time	12	15	20	25	ns
Maximum Operating Current	85	80	75	75	mA
Maximum CMOS Standby Current (low power)	500	500	500	500	μA

**Note:**

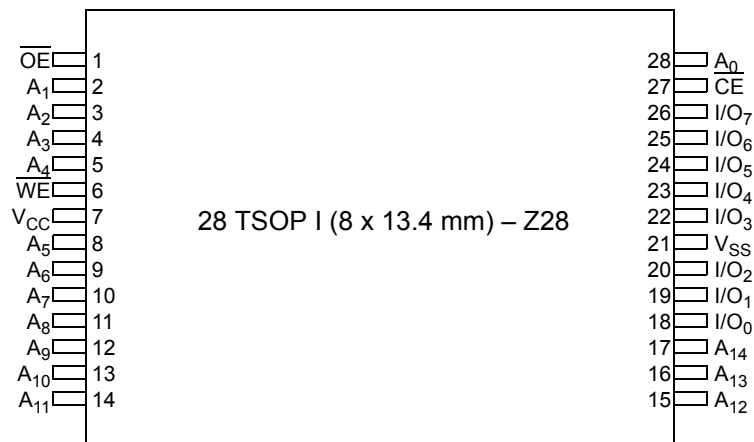
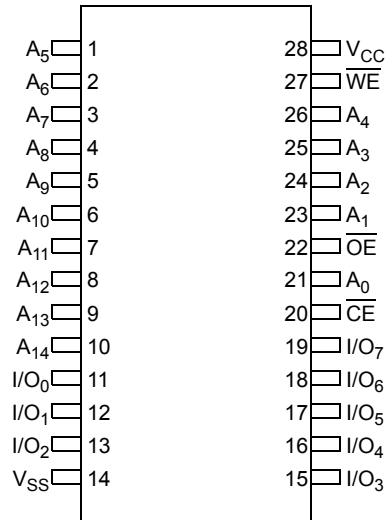
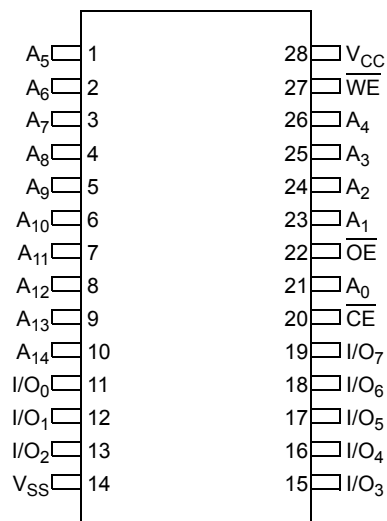
1. For best-practices recommendations, please refer to the Cypress application note *System Design Guidelines* on [www.cypress.com](http://www.cypress.com).

**Pin Layout and Specifications**
**28 DIP (6.9 x 35.6 x 3.5 mm) – P21**

**28 SOJ – V21**

**Pin Description**

Pin	Type	Description	DIP	SOJ	TSOP I
A <sub>x</sub>	Input	Address Inputs	1, 2, 3, 4, 5, 6, 7, 8, 9, 10, 21, 23, 24, 25, 26	1, 2, 3, 4, 5, 6, 7, 8, 9, 10, 21, 23, 24, 25, 26	2, 3, 4, 5, 8, 9, 10, 11, 12, 13, 14, 15, 16, 17, 28
CE	Control	Chip Enable	20	20	27
I/O <sub>x</sub>	Input or Output	Data Input/Outputs	11, 12, 13, 15, 16, 17, 18, 19	11, 12, 13, 15, 16, 17, 18, 19	18, 19, 20, 22, 23, 24, 25, 26
OE	Control	Output Enable	22	22	1
V <sub>CC</sub>	Supply	Power (5.0V)	28	28	7
V <sub>SS</sub>	Supply	Ground	14	14	21
WE	Control	Write Enable	27	27	6

**Truth Table**

$\overline{CE}$	$\overline{OE}$	$\overline{WE}$	I/O <sub>x</sub>	Mode	Power
H	X	X	High Z	Deselect / Power-Down	Standby ( $I_{BB}$ )
L	L	H	Data Out	Read	Active ( $I_{bc}$ )
L	X	L	Data In	Write	Active ( $I_{bc}$ )
L	H	H	High Z	Selected, outputs disabled	Active ( $I_{bc}$ )

**Maximum Ratings** (Above which the useful life may be impaired. For user guidelines, not tested.)

Parameter	Description	Value	Unit
T <sub>STG</sub>	Storage Temperature	-65 to +150	°C
T <sub>AMB</sub>	Ambient Temperature with Power Applied (i.e., case temperature)	-55 to +125	°C
V <sub>CC</sub>	Core Supply Voltage Relative to V <sub>SS</sub>	-0.5 to +7.0	V
V <sub>IN</sub> , V <sub>OUT</sub>	DC Voltage Applied to any Pin Relative to V <sub>SS</sub>	-0.5 to V <sub>CC</sub> + 0.5	V
I <sub>OUT</sub>	Output Short-Circuit Current	20	mA
V <sub>ESD</sub>	Static Discharge Voltage (per MIL-STD-883, Method 3015)	> 2001	V
I <sub>LU</sub>	Latch-up Current	> 200	mA

### Operating Range

Range	Ambient Temperature (T <sub>A</sub> )	Voltage Range (V <sub>CC</sub> )
Commercial	0°C to 70°C	5.0V ± 10%
Industrial	-40°C to 85°C	5.0V ± 10%

### DC Electrical Characteristics Over the Operating Range (-12, -15)<sup>[2]</sup>

Parameter	Description	Condition	Power	12 ns		15 ns		Unit
				Min.	Max.	Min.	Max.	
V <sub>IH</sub>	Input HIGH Voltage		-	2.2	V <sub>CC</sub> + 0.3	2.2	V <sub>CC</sub> + 0.3	V
V <sub>IL</sub>	Input LOW Voltage		-	-0.5	0.8	-0.5	0.8	V
V <sub>OH</sub>	Output HIGH Voltage	V <sub>CC</sub> = Min., I <sub>OH</sub> = -4.0 mA	-	2.4	-	2.4	-	V
V <sub>OL</sub>	Output LOW Voltage	V <sub>CC</sub> = Min., I <sub>OL</sub> = 8.0 mA	-	-	0.4	-	0.4	V
I <sub>CC</sub>	V <sub>CC</sub> Operating Supply Current	V <sub>CC</sub> = Max., I <sub>OUT</sub> = 0 mA, f = F <sub>MAX</sub> = 1/t <sub>RC</sub>	-	-	85	-	80	mA
I <sub>SB1</sub>	Automatic $\overline{CE}$ Power-down Current TTL Inputs	Max. V <sub>CC</sub> , $\overline{CE} \geq V_{IH}$ , V <sub>IN</sub> ≥ V <sub>IH</sub> or V <sub>IN</sub> ≤ V <sub>IL</sub> , f = F <sub>MAX</sub>	-	-	30	-	30	mA
			L	-	10	-	10	mA
I <sub>SB2</sub>	Automatic $\overline{CE}$ Power-down Current CMOS Inputs	Max. V <sub>CC</sub> , $\overline{CE} \geq V_{CC} - 0.3V$ , V <sub>IN</sub> ≥ V <sub>CC</sub> - 0.3V, or V <sub>IN</sub> ≤ 0.3V, f = 0	-	-	10	-	10	mA
			L	-	500	-	500	μA
I <sub>OZ</sub>	Output Leakage Current	GND ≤ V <sub>i</sub> ≤ V <sub>CC</sub> , Output Disabled	-	-5	+5	-5	+5	μA
I <sub>IX</sub>	Input Load Current	GND ≤ V <sub>i</sub> ≤ V <sub>CC</sub>	-	-5	+5	-5	+5	μA

### DC Electrical Characteristics Over the Operating Range (-20, -25)<sup>[2]</sup>

Parameter	Description	Condition	Power	20 ns		25 ns		Unit
				Min.	Max.	Min.	Max.	
V <sub>IH</sub>	Input HIGH Voltage		-	2.2	V <sub>CC</sub> + 0.3	2.2	V <sub>CC</sub> + 0.3	V
V <sub>IL</sub>	Input LOW Voltage		-	-0.5	0.8	-0.5	0.8	V
V <sub>OH</sub>	Output HIGH Voltage	V <sub>CC</sub> = Min., I <sub>OH</sub> = -4.0 mA	-	2.4	-	2.4	-	V
V <sub>OL</sub>	Output LOW Voltage	V <sub>CC</sub> = Min., I <sub>OL</sub> = 8.0 mA	-	-	0.4	-	0.4	V
I <sub>CC</sub>	V <sub>CC</sub> Operating Supply Current	V <sub>CC</sub> = Max., I <sub>OUT</sub> = 0 mA, f = F <sub>MAX</sub> = 1/t <sub>RC</sub>	-	-	75	-	75	mA
I <sub>SB1</sub>	Automatic $\overline{CE}$ Power-down Current TTL Inputs	Max. V <sub>CC</sub> , $\overline{CE} \geq V_{IH}$ , V <sub>IN</sub> ≥ V <sub>IH</sub> or V <sub>IN</sub> ≤ V <sub>IL</sub> , f = F <sub>MAX</sub>	-	-	30	-	30	mA
			L	-	10	-	10	mA

Note:

- V<sub>IL</sub> (min) = -2.0V for pulse durations of less than 20 ns.

**DC Electrical Characteristics** Over the Operating Range (-20, +25)<sup>[2]</sup> (continued)

Parameter	Description	Condition	Power	20 ns		25 ns		Unit
				Min.	Max.	Min.	Max.	
I <sub>SB2</sub>	Automatic CE Power-down Current CMOS Inputs	Max. V <sub>CC</sub> , CE ≥ V <sub>CC</sub> - 0.3V, V <sub>IN</sub> ≥ V <sub>CC</sub> - 0.3V, or V <sub>IN</sub> ≤ 0.3V, f = 0	-	-	10	-	10	mA
			L	-	500	-	500	μA
I <sub>OZ</sub>	Output Leakage Current	GND ≤ V <sub>i</sub> ≤ V <sub>CC</sub> , Output Disabled	-	-5	+5	-5	+5	μA
I <sub>IX</sub>	Input Load Current	GND ≤ V <sub>i</sub> ≤ V <sub>CC</sub>	-	-5	+5	-5	+5	μA

**Capacitance<sup>[3]</sup>**

Parameter	Description	Conditions	Max.	Unit
			ALL - PACKAGES	
C <sub>IN</sub>	Input Capacitance	T <sub>A</sub> = 25°C, f = 1 MHz, V <sub>CC</sub> = 5.0V	8	pF
C <sub>OUT</sub>	Output Capacitance		8	

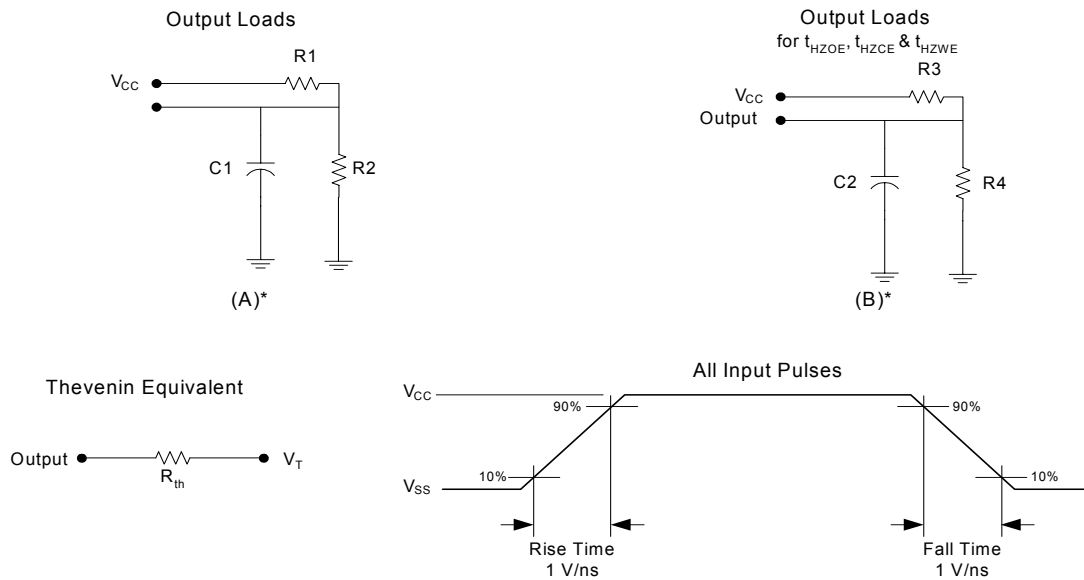
**AC Test Loads**

\* including scope and jig capacitance

**AC Test Conditions**

Parameter	Description	Nom.	Unit
C1	Capacitor 1	30	pF
C2	Capacitor 2	5	
R1	Resistor 1	480	Ω
R2	Resistor 2	255	
R3	Resistor 3	480	
R4	Resistor 4	255	
R <sub>TH</sub>	Resistor Thevenin	167	
V <sub>TH</sub>	Voltage Thevenin	1.73	V

**Note:**

3. Tested initially and after any design or process change that may affect these parameters.

**Thermal Resistance<sup>[4]</sup>**

Parameter	Description	Conditions	TSOP I	SOJ	DIP	Unit
$\Theta_{JA}$	Thermal Resistance (Junction to Ambient)	Still Air, soldered on a 3 × 4.5 square inch, two-layer printed circuit board	88.6	79	TBD	°C/W
$\Theta_{JC}$	Thermal Resistance (Junction to Case)		21.94	41.42	TBD	

**AC Electrical Characteristics<sup>[5, 6, 7]</sup>**

Parameter	Description	12 ns		15 ns		20 ns		25 ns		Unit
		Min	Max	Min	Max	Min	Max	Min	Max	
$t_{RC}$	Read Cycle Time	12	–	15	–	20	–	25	–	ns
$t_{AA}$	Address to Data Valid	–	12	–	15	–	20	–	25	ns
$t_{OHA}$	Data Hold from Address Change	3	–	3	–	3	–	3	–	ns
$t_{ACE}$	$\overline{CE}$ to Data Valid	–	12	–	15	–	20	–	25	ns
$t_{DOE}$	$\overline{OE}$ to Data Valid	–	5	–	7	–	9	–	9	ns
$t_{LZOE}$	$\overline{OE}$ to Low Z	0	–	0	–	0	–	0	–	ns
$t_{HZOE}$	$\overline{OE}$ to High Z	–	5	–	7	–	9	–	9	ns
$t_{LZCE}$	$\overline{CE}$ to Low Z	3	–	3	–	3	–	3	–	ns
$t_{HZCE}$	$\overline{CE}$ to High Z	–	5	–	7	–	9	–	9	ns
$t_{PU}$	$\overline{CE}$ to Power-up	0	–	0	–	0	–	0	–	ns
$t_{PD}$	$\overline{CE}$ to Power-down	–	12	–	15	–	20	–	20	ns
$t_{WC}$	Write Cycle Time	12	–	15	–	20	–	25	–	ns
$t_{SCE}$	$\overline{CE}$ to Write End	9	–	10	–	15	–	15	–	ns
$t_{AW}$	Address Set-up to Write End	9	–	10	–	15	–	15	–	ns
$t_{HA}$	Address Hold from Write End	0	–	0	–	0	–	0	–	ns
$t_{SA}$	Address Set-up to Write Start	0	–	0	–	0	–	0	–	ns
$t_{PWE}$	$\overline{WE}$ Pulse Width	8	–	9	–	15	–	15	–	ns
$t_{SD}$	Data Set-up to Write End	8	–	9	–	10	–	10	–	ns
$t_{HD}$	Data Hold from Write End	0	–	0	–	0	–	0	–	ns
$t_{HZWE}$	$\overline{WE}$ LOW to High Z	–	7	–	7	–	10	–	10	ns
$t_{LZWE}$	$\overline{WE}$ HIGH to Low Z	3	–	3	–	3	–	3	–	ns

**Data Retention Characteristics<sup>[8]</sup>**

Parameter	Description	Condition	ALL		Unit
			Min	Max	
$V_{DR}$	$V_{CC}$ for Data Retention		2.0	–	V
$I_{CCDR}$	Data Retention Current	$V_{CC} = V_{DR} = 2.0V, \overline{CE} \geq V_{CC} - 0.3V, V_{IN} \geq V_{CC} - 0.3V$ or $V_{IN} \leq 0.3V$	–	150	mA
$t_{CDR}$	Chip Deselect to Data Retention Time		0	–	ns
$t_R$	Operation Recovery Time		200	–	$\mu$ s

**Notes:**

- Test Conditions assume a transition time of 3 ns or less, timing reference levels of 1.5V, input pulse levels of 0 to 3.0V.
- At any given temperature and voltage condition,  $t_{HZCE}$  is less than  $t_{LZCE}$ ,  $t_{HZOE}$  is less than  $t_{LZOE}$ , and  $t_{HZWE}$  is less than  $t_{LZWE}$  for any given device.
- The internal write time of the memory is defined by the overlap of  $\overline{CE}$  LOW and  $\overline{WE}$  LOW.  $\overline{CE}$  and  $\overline{WE}$  must be LOW to initiate a write, and the transition of any of these signals can terminate the write. The input data set-up and hold timing should be referenced to the leading edge of the signal that terminates the write.
- $t_{HZOE}$ ,  $t_{HZCE}$ ,  $t_{HZWE}$  are specified as in part (b) of the A/C Test Loads. Transitions are measured  $\pm 200$  mV from steady state voltage.
- L-version only.

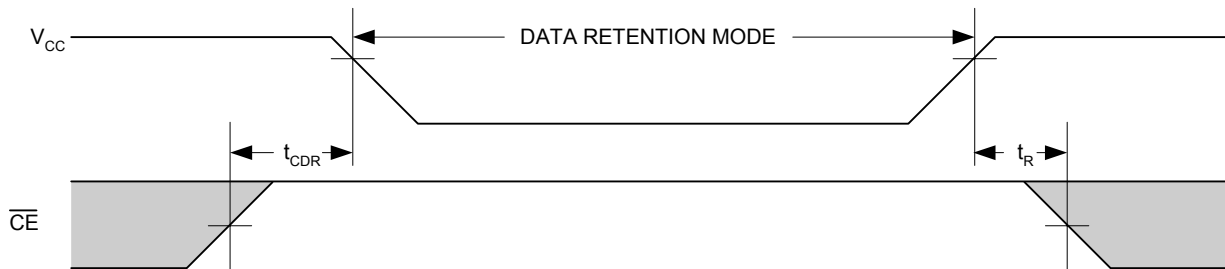
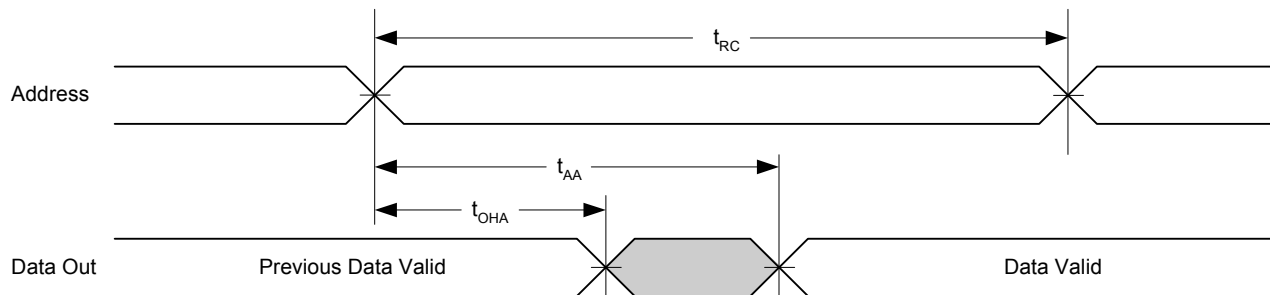
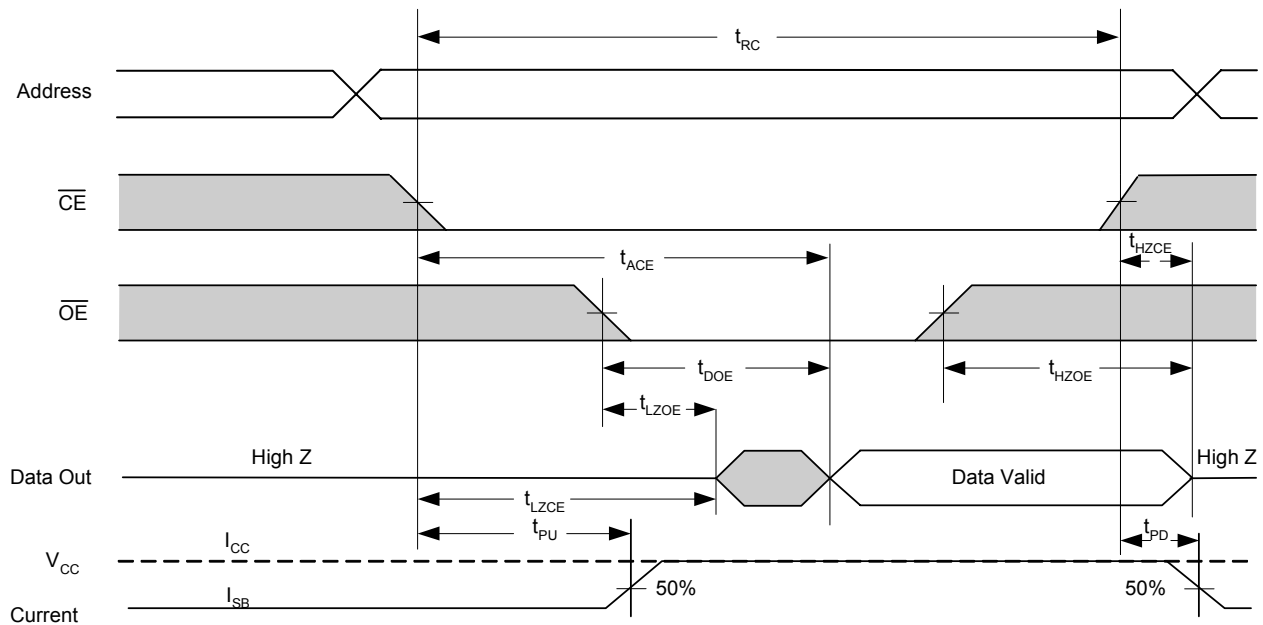
**Timing Waveforms**
**Data Retention Waveform**

**Read Cycle No. 1<sup>[9, 10]</sup>**

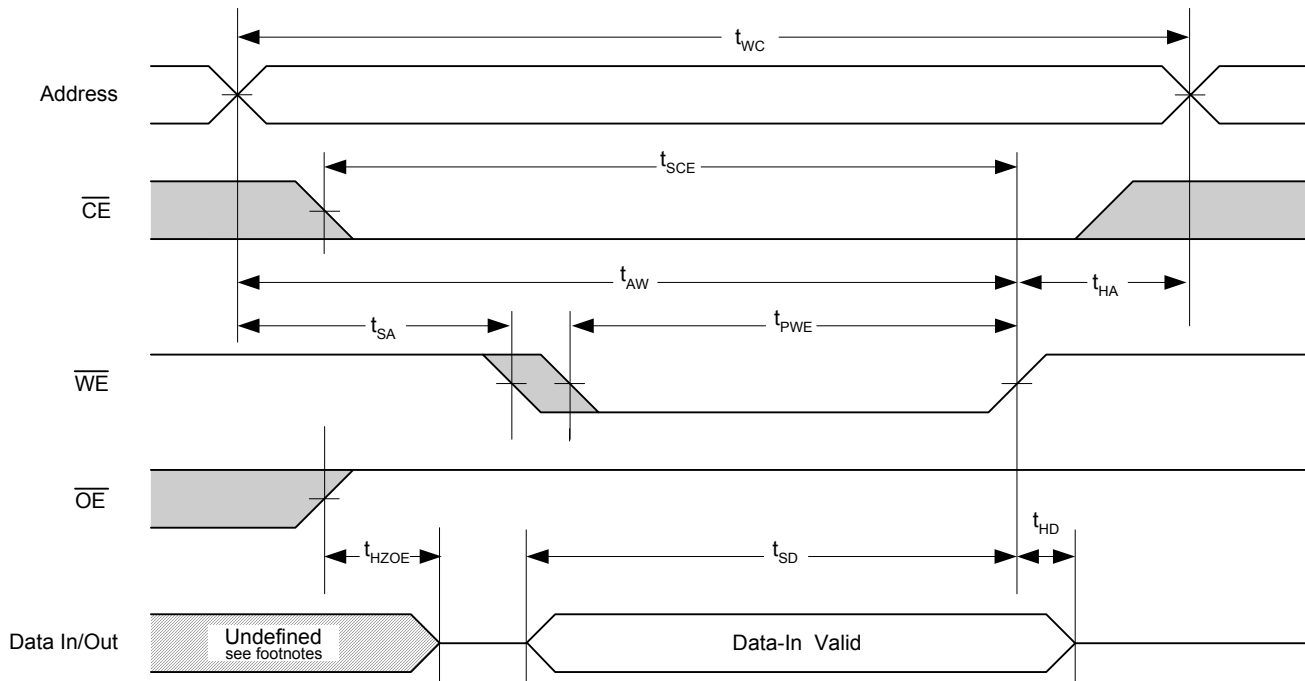
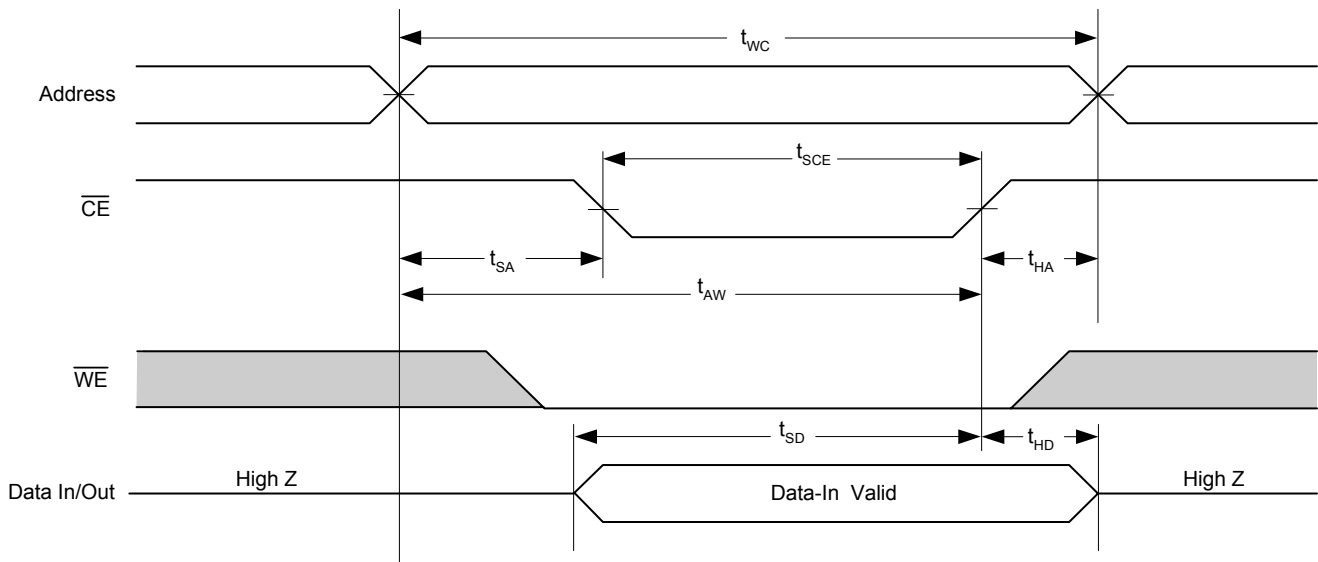
**Read Cycle No. 2<sup>[11, 12]</sup>**

**Notes:**

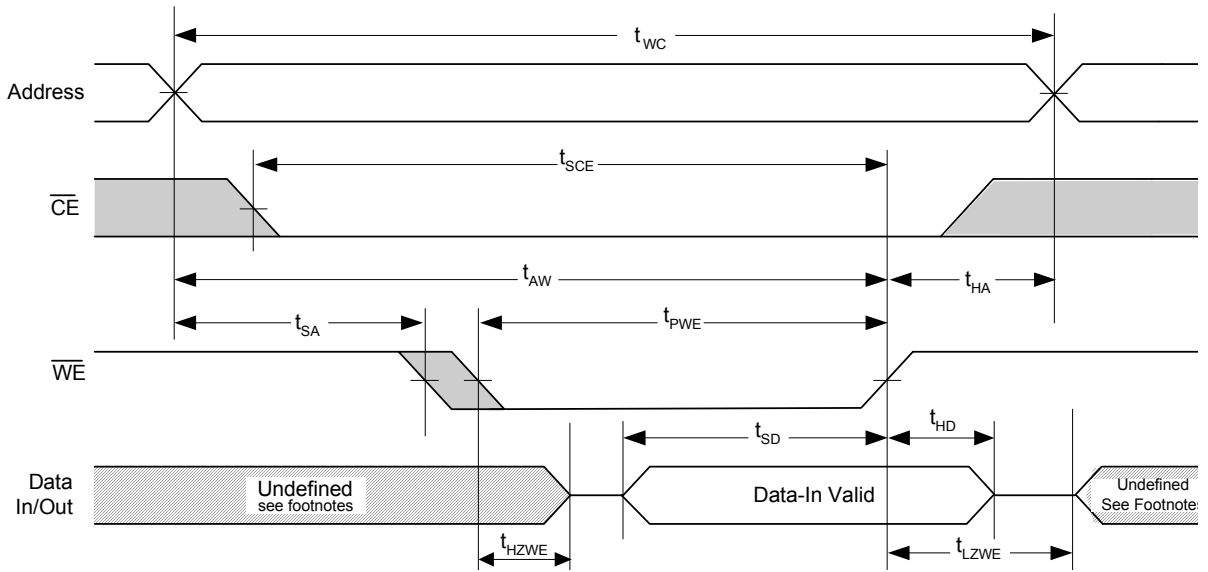
9. Device is continuously selected.  $\overline{OE} = V_{IL} = \overline{CE}$ .
10.  $\overline{WE}$  is HIGH for Read Cycle.
11. This cycle is  $\overline{OE}$  Controlled and  $\overline{WE}$  is HIGH read cycle.
12. Address valid prior to or coincident with  $\overline{CE}$  transition LOW.

**Timing Waveforms (continued)**
**Write Cycle No. 1 ( $\overline{WE}$  Controlled)<sup>[13, 14, 15]</sup>**

**Write Cycle No. 2 ( $\overline{CE}$  Controlled)<sup>[14, 16, 17]</sup>**

**Notes:**

13. This cycle is  $\overline{WE}$  controlled,  $\overline{OE}$  is HIGH during write.
14. Data In/Out is high impedance if  $\overline{OE} = V_{IH}$ .
15. During this period the I/Os are in output state and input signals should not be applied.
16. This cycle is  $\overline{CE}$  controlled.
17. If  $\overline{CE}$  goes HIGH simultaneously with  $\overline{WE}$  going HIGH, the output remains in a high-impedance state.

**Timing Waveforms (continued)**
**Write Cycle No. 3 ( $\overline{WE}$  Controlled,  $\overline{OE}$  Low)<sup>[18]</sup>**

**Note:**

18. The cycle is  $\overline{WE}$  controlled,  $\overline{OE}$  LOW. The minimum write cycle time is the sum of  $t_{HZWE}$  and  $t_{SD}$ .

**Ordering Information**

Speed	Ordering Code	Package Name	Package Type	Power Option	Operating Range
12 ns	CY7C199C-12VC	V21	28 SOJ	Standard	Commercial
12 ns	CY7C199C-12VXC	V21	28 SOJ (Pb-Free)	Standard	Commercial
12 ns	CY7C199C-12ZC	Z28	28 TSOP I (8 x 13.4 mm)	Standard	Commercial
12 ns	CY7C199C-12ZXC	Z28	28 TSOP I (8 x 13.4 mm) (Pb-Free)	Standard	Commercial
12 ns	CY7C199C-12VI	V21	28 SOJ	Standard	Industrial
12 ns	CY7C199C-12VXI	V21	28 SOJ (Pb-Free)	Standard	Industrial
15 ns	CY7C199C-15PC	P21	28 DIP (6.9 x 35.6 x 3.5 mm)	Standard	Commercial
15 ns	CY7C199C-15PXC	P21	28 DIP (6.9 x 35.6 x 3.5 mm) (Pb-Free)	Standard	Commercial
15 ns	CY7C199C-15VC	V21	28 SOJ	Standard	Commercial
15 ns	CY7C199C-15VXC	V21	28 SOJ (Pb-Free)	Standard	Commercial
15 ns	CY7C199C-15ZC	Z28	28 TSOP I (8 x 13.4 mm)	Standard	Commercial
15 ns	CY7C199C-15ZXC	Z28	28 TSOP I (8 x 13.4 mm) (Pb-Free)	Standard	Commercial
15 ns	CY7C199C-15VI	V21	28 SOJ	Standard	Industrial
15 ns	CY7C199C-15VXI	V21	28 SOJ (Pb-Free)	Standard	Industrial
15 ns	CY7C199CL-15VC	V21	28 SOJ	Low Power	Commercial
15 ns	CY7C199CL-15VXC	V21	28 SOJ (Pb-Free)	Low Power	Commercial
15 ns	CY7C199CL-15ZC	Z28	28 TSOP I (8 x 13.4 mm)	Low Power	Commercial
15 ns	CY7C199CL-15ZXC	Z28	28 TSOP I (8 x 13.4 mm) (Pb-Free)	Low Power	Commercial
15 ns	CY7C199CL-15VI	V21	28 SOJ	Low Power	Industrial
15 ns	CY7C199CL-15VXI	V21	28 SOJ (Pb-Free)	Low Power	Industrial
20 ns	CY7C199C-20VC	V21	28 SOJ	Standard	Commercial
20 ns	CY7C199C-20VXC	V21	28 SOJ (Pb-Free)	Standard	Commercial
20 ns	CY7C199C-20ZI	Z28	28 TSOP I (8 x 13.4 mm)	Standard	Industrial
20 ns	CY7C199C-20ZXI	Z28	28 TSOP I (8 x 13.4 mm) (Pb-Free)	Standard	Industrial
25 ns	CY7C199C-25PC	P21	28 DIP (6.9 x 35.6 x 3.5 mm)	Standard	Commercial
25 ns	CY7C199C-25PXC	P21	28 DIP (6.9 x 35.6 x 3.5 mm) (Pb-Free)	Standard	Commercial

**Package Diagram**
**28-Lead Thin Small Outline Package Type 1 (8 x 13.4 mm) Z28**

NOTE: ORIENTATION I.D. MAY BE LOCATED EITHER AS SHOWN IN OPTION 1 OR OPTION 2

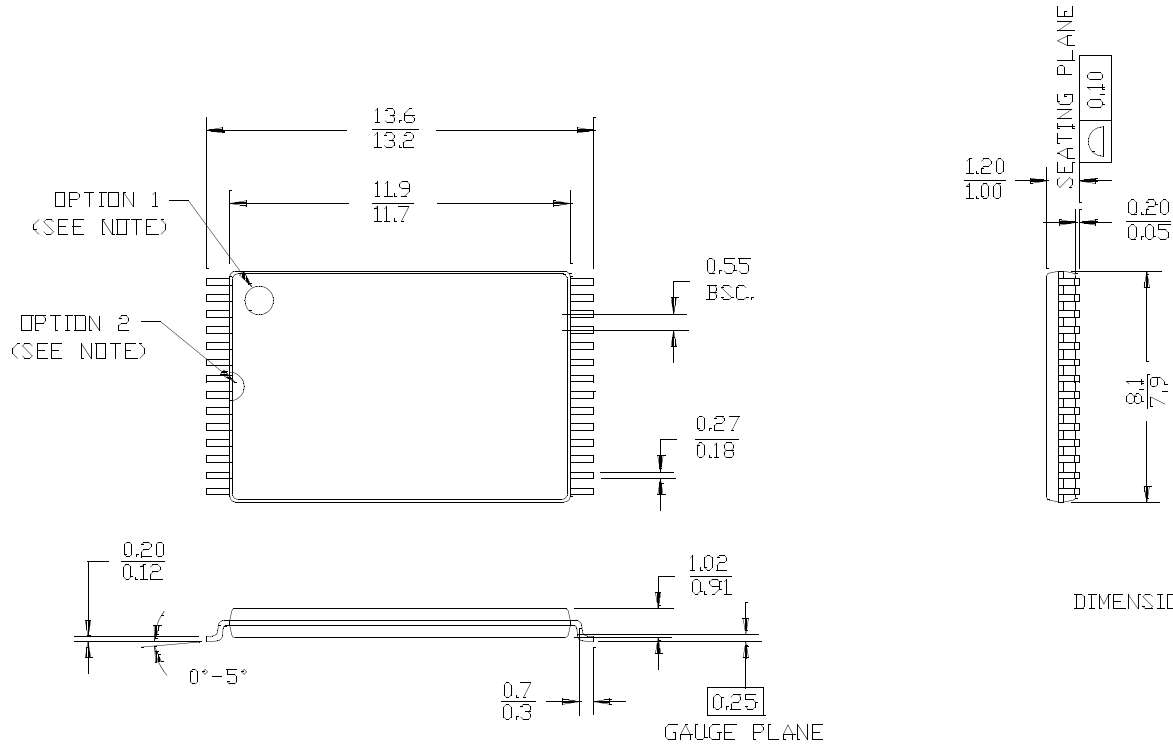

**Package Diagram (continued)**

**28-Lead (300-Mil) Molded SOJ V21**

DIMENSIONS IN INCHES

MIN.  
MAX.

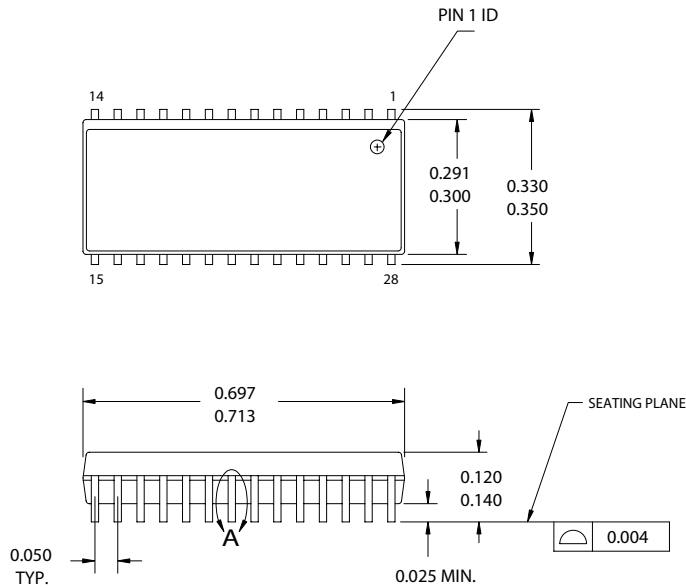

DETAIL **A**  
EXTERNAL LEAD DESIGN

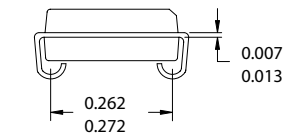
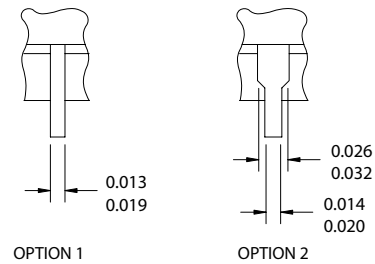

51-85031-\*B

**28-Lead (300-Mil) PDIP P21**

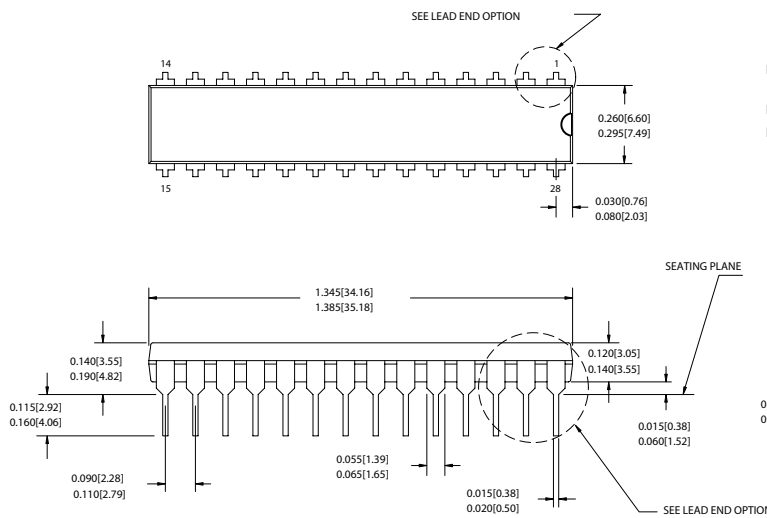

DIMENSIONS IN INCHES [MM] MIN.  
MAX.  
REFERENCE JEDEC MO-095  
PACKAGE WEIGHT: 2.15 gms

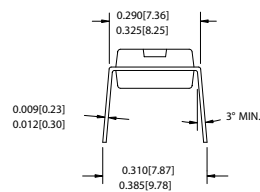

LEAD END OPTION  
(LEAD #1, 14, 15 & 28)

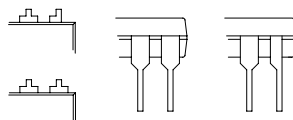

51-85014-\*D

All product and company names mentioned in this document may be the trademarks of their respective holders.

**Document History Page**

<b>Document Title: CY7C199C 256K (32K x 8) Static RAM</b> <b>Document Number: 38-05408</b>				
<b>REV.</b>	<b>ECN No.</b>	<b>Issue Date</b>	<b>Orig. of Change</b>	<b>Description of Change</b>
**	129233	09/11/03	HGK	New Data Sheet
*A	129697	09/15/03	KKV	Minor change: Move Product Portfolio from page 4 to page 1 Move Truth table from page 9 to page 3
*B	341574	See ECN	PCI	Added Lead-Free part to Ordering info on Page #10

## Looking for pricing, stock, or lifecycle information?

Click below to explore more details on WIN SOURCE:

 [View CY7C199C-25PC on WIN SOURCE](#)

 [Cypress Semiconductor Corp](#) Information

## Optimize Your Supply Chain with WIN SOURCE Solutions

-  Global Sourcing Solution
-  Obsolete Management
-  Cost Control Management
-  Shortage Management
-  Alternative Solution
-  Excess Inventory Management