



**THE DATASHEET OF
CY7C168A-20PXC**



Features

- Automatic power-down when deselected
- Complementary metal oxide semiconductor (CMOS) for optimum speed/power
- High speed
 - $t_{AA} = 20 \text{ ns}$
- Low active power
 - 495 mW
- Low standby power
 - 110 mW
- TTL-compatible inputs and outputs
- V_{IH} of 2.2 V
- Capable of withstanding greater than 2001 V electrostatic discharge

Functional Description

The CY7C168A is a high-performance CMOS static RAM organized as 4096 by 4-bits. Easy memory expansion is provided by an active LOW chip enable (\overline{CE}) and three-state drivers. The CY7C168A has an automatic power-down feature, reducing the power consumption by 77% when deselected.

Writing to the device is accomplished when the chip select (\overline{CE}) and write enable (\overline{WE}) inputs are both LOW. Data on the four data input/output pins (I/O_0 through I/O_3) is written into the memory location specified on the address pins (A_0 through A_{11}).

Reading the device is accomplished by taking the chip enable (\overline{CE}) LOW, while write enable (\overline{WE}) remains HIGH. Under these conditions, the contents of the location specified on the address pins will appear on the four data input/output pins (I/O_0 through I/O_3).

The input/output pins remain in a high-impedance state when chip enable (\overline{CE}) is HIGH or write enable (\overline{WE}) is LOW.

A die coat is used to insure alpha immunity.

Logic Block Diagram

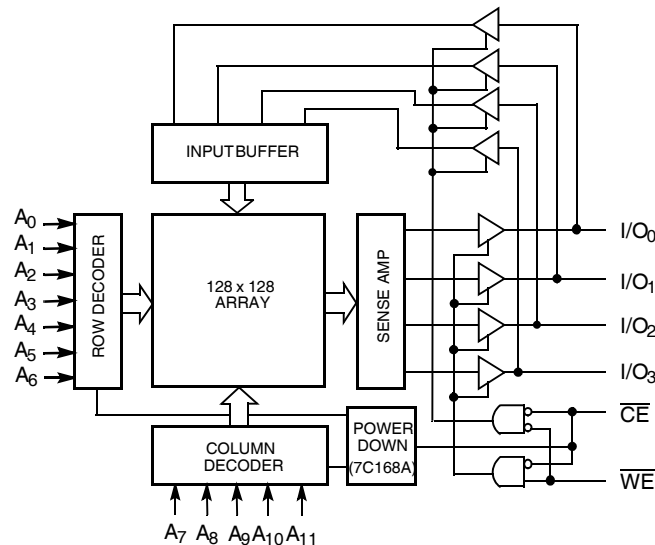

C168A-1

Contents

Pin Configuration	3	Ordering Information	9
Selection Guide	3	Ordering Code Definitions	9
Maximum Ratings	4	Package Diagram	9
Operating Range	4	Acronyms	10
Electrical Characteristics	4	Document Conventions	10
Capacitance	5	Units of Measure	10
AC Test Loads and Waveforms	5	Document History Page	11
Switching Characteristics	6	Sales, Solutions, and Legal Information	12
Switching Waveforms	6	Worldwide Sales and Design Support	12
Typical DC and AC Characteristics	8	Products	12
		PSoC Solutions	12

Pin Configuration

Figure 1. DIP Top View

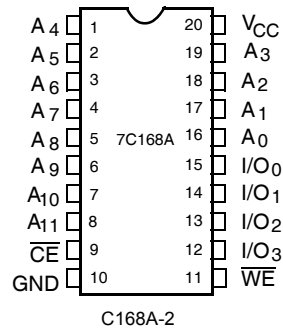

Selection Guide

		7C168A-20
Maximum access time (ns)		20
Maximum operating current (mA)	Commercial	90
	Military	100

Maximum Ratings

Exceeding maximum ratings may impair the useful life of the device. These user guidelines are not tested.

- Storage temperature -65 °C to +150 °C
- Ambient temperature with power applied..... -55 °C to +125 °C
- Supply voltage to ground potential (pin 20 to pin 10)..... -0.5 V to +7.0 V
- DC voltage applied to outputs in high Z state..... -0.5 V to +7.0 V
- DC input voltage -3.0 V to +7.0 V

- Output current into outputs (low) 20 mA
- Static discharge voltage..... > 2001 V (per MIL-STD-883, method 3015)
- Latch-up current > 200 mA

Operating Range

Range	Ambient Temperature	V _{CC}
Commercial	0 °C to +70 °C	5 V ± 10%

Electrical Characteristics

Over the Operating Range

Parameter	Description	Test Conditions	7C168A-20		Unit
			Min	Max	
V _{OH}	Output HIGH voltage	V _{CC} = Min, I _{OH} = -4.0 mA	2.4	-	V
V _{OL}	Output LOW voltage	V _{CC} = Min, I _{OL} = 8.0 mA	-	0.4	V
V _{IH}	Input HIGH voltage		2.2	V _{CC}	V
V _{IL}	Input LOW voltage ^[1]		-0.5	0.8	V
I _{IX}	Input load current	GND ≤ V _I ≤ V _{CC}	-10	+10	µA
I _{OZ}	Output leakage current	GND ≤ V _O ≤ V _{CC} , output disabled	-10	+10	µA
I _{OS}	Output short circuit current ^[2]	V _{CC} = Max, V _{OUT} = GND	-	-350	mA
I _{CC}	V _{CC} operating supply current	V _{CC} = Max, I _{OUT} = 0 mA	-	90	mA
I _{SB1}	Automatic \overline{CE} power-down current	Max V _{CC} , $\overline{CE} \geq V_{IH}$	-	40	mA
I _{SB2}	Automatic \overline{CE} power-down current	Max V _{CC} , $\overline{CE} \geq V_{CC} - 0.3 V$	-	20	mA

Notes

1. V_{IL} min = -3.0 V for pulse durations less than 30 ns.
2. Not more than 1 output should be shorted at one time. Duration of the short circuit should not exceed 30 seconds.

Capacitance^[3]

Parameter	Description	Test Conditions	Max	Unit
C _{IN}	Input capacitance	T _A = 25 °C, f = 1 MHz, V _{CC} = 5.0 V	10	pF
C _{OUT}	Output capacitance		10	pF

AC Test Loads and Waveforms

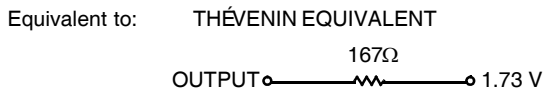
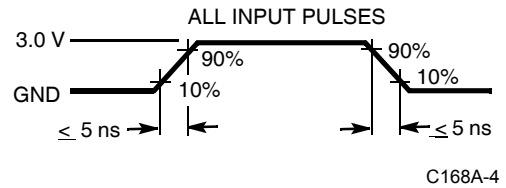
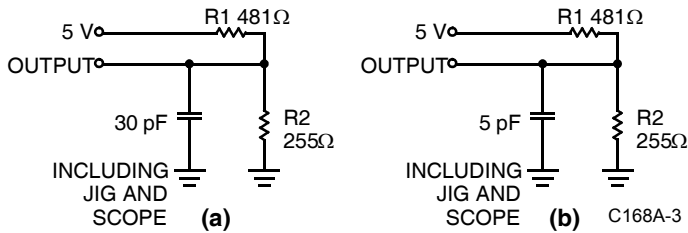

Note
3. Tested initially and after any design or process changes that may affect these parameters.

Switching Characteristics

Over the Operating Range^[4]

Parameter	Description	7C168A-20		Unit
		Min.	Max.	
READ CYCLE				
t_{RC}	Read cycle time	20	–	ns
t_{AA}	Address to data valid	–	20	ns
t_{OHA}	Output hold from address change	5	–	ns
t_{ACE}	\overline{CE} LOW to data valid	–	20	ns
t_{LZCE}	\overline{CE} LOW to low Z ^[5]	5	–	ns
t_{HZCE}	\overline{CE} HIGH to high Z ^[5, 6]	–	8	ns
t_{PU}	\overline{CE} LOW to power-up	0	–	ns
t_{PD}	\overline{CE} HIGH to power-down	–	20	ns
t_{RCS}	Read command set-up	0	–	ns
t_{RCH}	Read command hold	0	–	ns
WRITE CYCLE^[7]				
t_{WC}	Write cycle time	20	–	ns
t_{SCE}	\overline{CE} LOW to write end	15	–	ns
t_{AW}	Address set-up to write end	15	–	ns
t_{HA}	Address hold from write end	0	–	ns
t_{SA}	Address set-up to write start	0	–	ns
t_{PWE}	\overline{WE} pulse width	15	–	ns
t_{SD}	Data set-up to write end	10	–	ns
t_{HD}	Data hold from write end	0	–	ns
t_{LZWE}	\overline{WE} HIGH to low Z ^[5]	7	–	ns
t_{HZWE}	\overline{WE} LOW to high Z ^[5, 6]	5	–	ns

Switching Waveforms

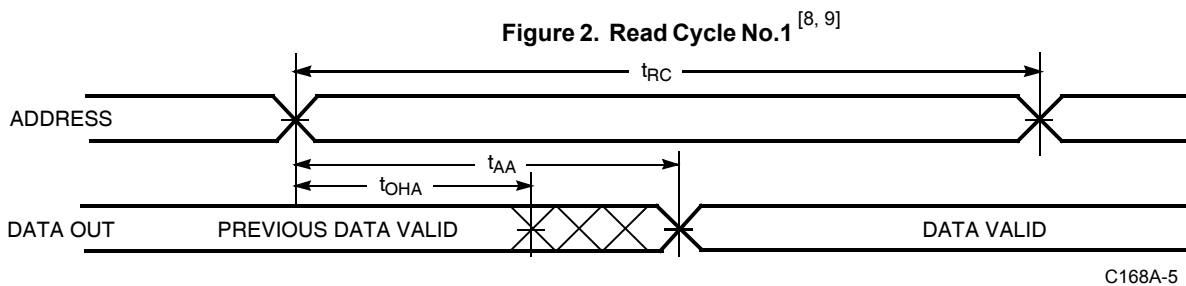

Notes

4. Test conditions assume signal transition times of 5 ns or less, timing reference levels of 1.5 V, input pulse levels of 0 to 3.0 V, and output loading of the specified I_{OL}/I_{OH} and 30 pF load capacitance.
5. At any given temperature and voltage condition, t_{HZ} is less than t_{LZ} for all devices. Transition is measured ± 500 mV from steady state voltage with specified loading in part (b) of AC Test Loads and Waveforms.
6. t_{HZCE} and t_{HZWE} are tested with $C_L = 5$ pF as in part (a) of Test Loads and Waveforms. Transition is measured ± 500 mV from steady state voltage.
7. The internal write time of the memory is defined by the overlap of \overline{CE} LOW and \overline{WE} LOW. Both signal must be LOW to initiate a write and either signal can terminate a write by going high. The data input set-up and hold timing should be referenced to the rising edge of the signal that terminates the write.
8. \overline{WE} is HIGH for read cycle.
9. Device is continuously selected, $\overline{CE} = V_{IL}$.

Switching Waveforms (continued)

Figure 3. Read Cycle^[10, 11]

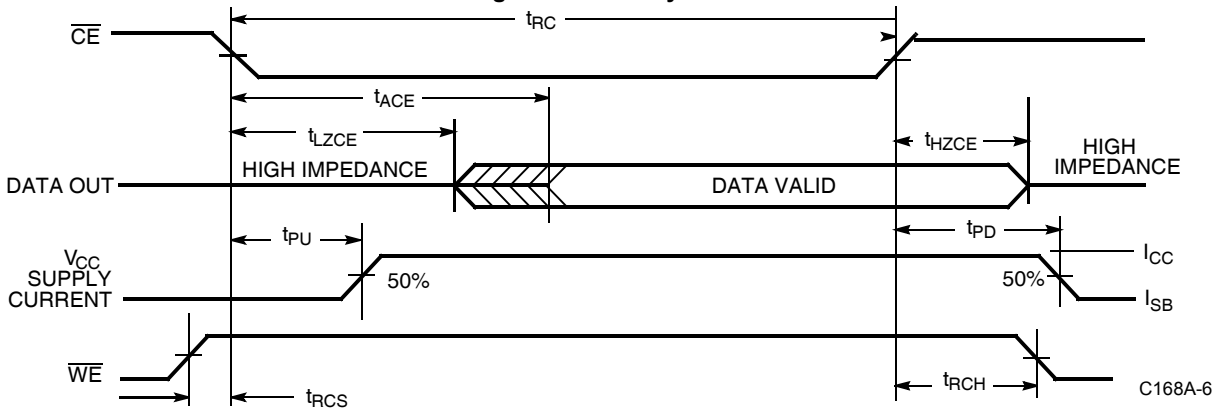

Figure 4. Write Cycle No.1 (WE Controlled)^[12]

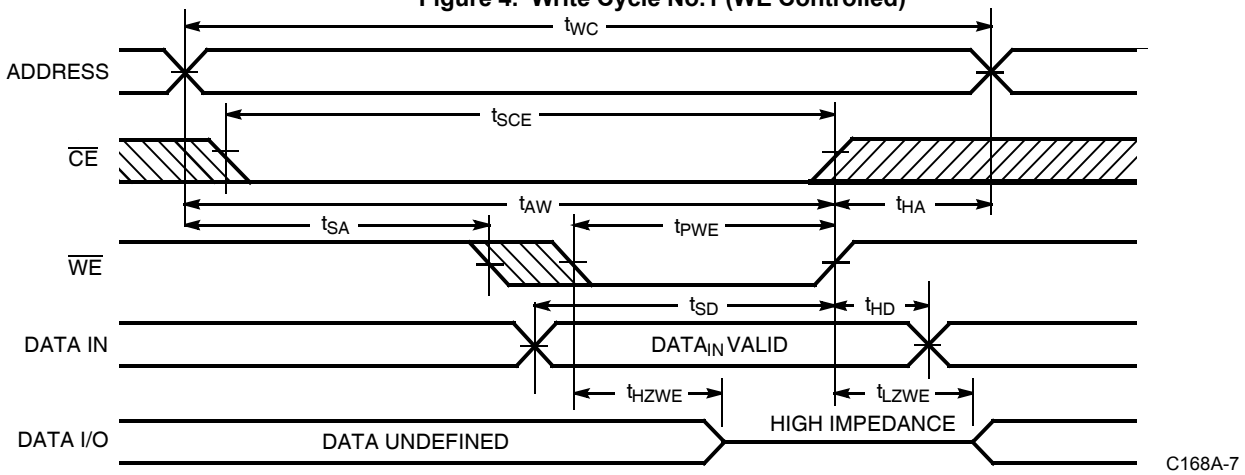
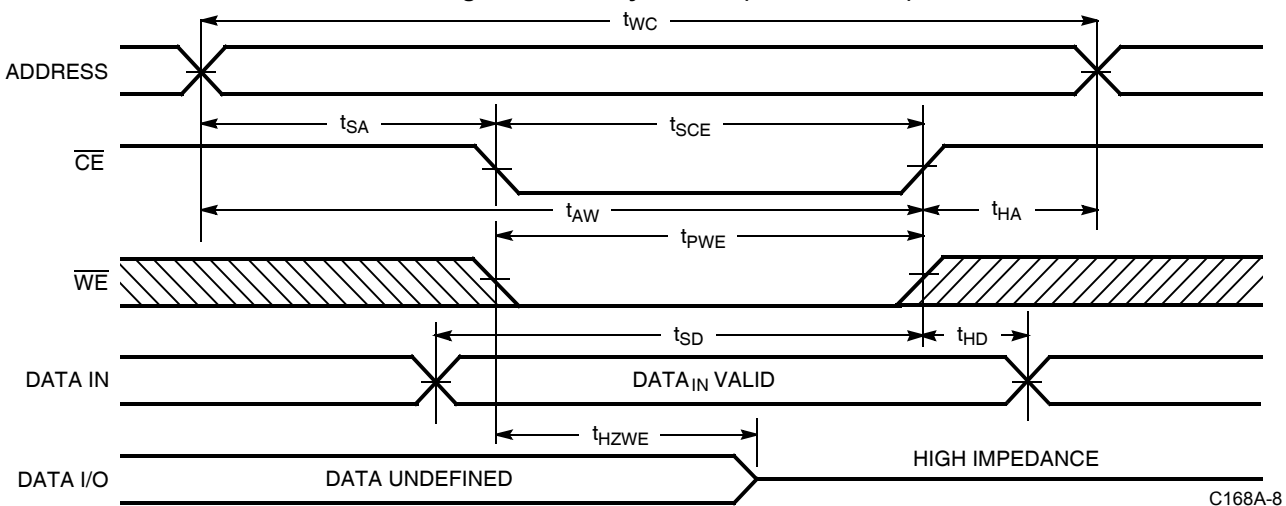

Figure 5. Write Cycle No. 2 (CS Controlled)^[12, 13]



Notes

- 10. WE is HIGH for read cycle.
- 11. Address valid prior to or coincident with CE transition LOW.
- 12. The internal write time of the memory is defined by the overlap of CE LOW and WE LOW. Both signal must be LOW to initiate a write and either signal can terminate a write by going high. The data input set-up and hold timing should be referenced to the rising edge of the signal that terminates the write.
- 13. If CE goes HIGH simultaneously with WE HIGH, the output remains in a high-impedance state.

Typical DC and AC Characteristics

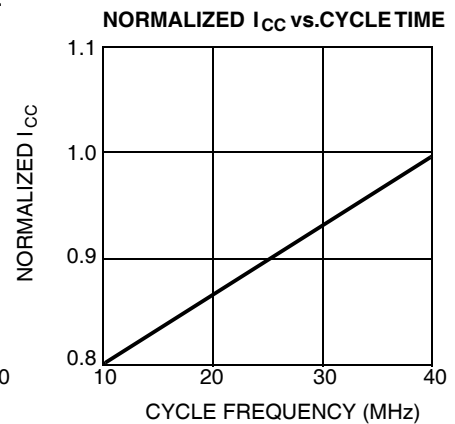
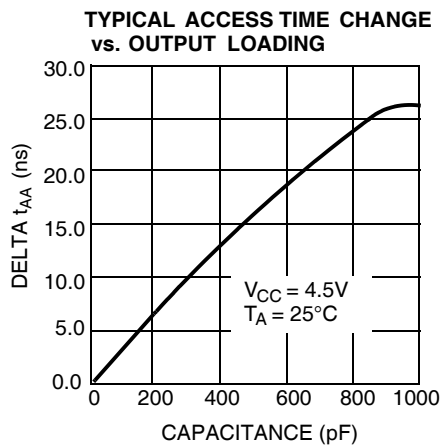
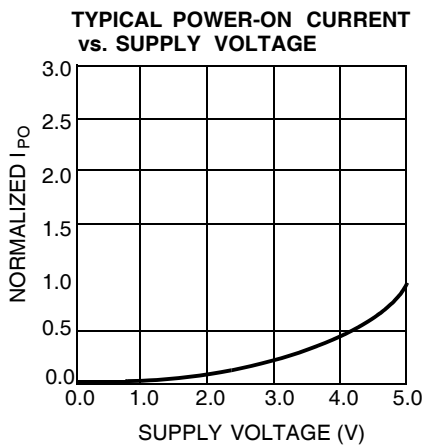
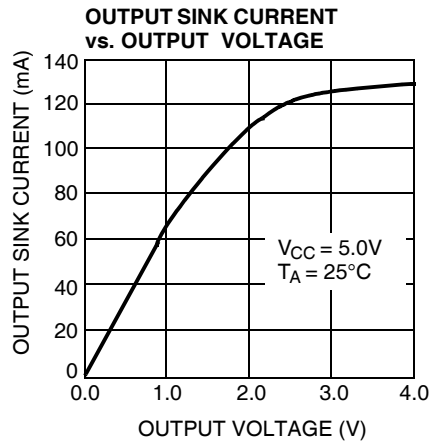
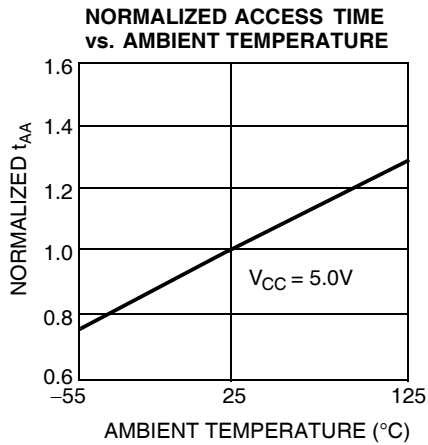
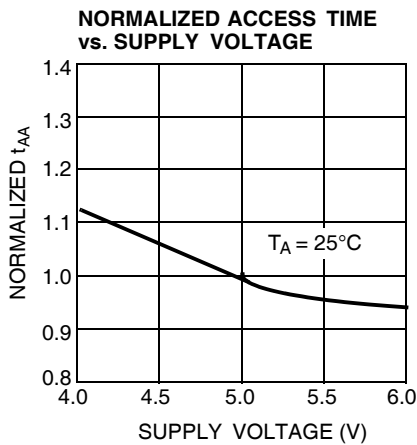
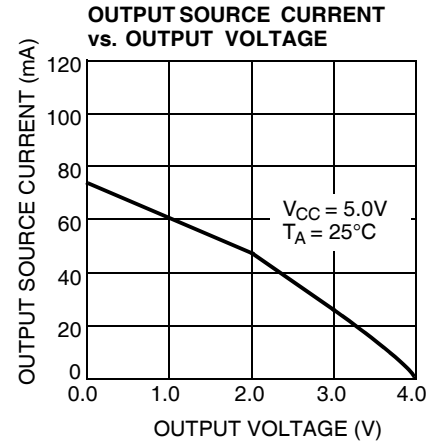
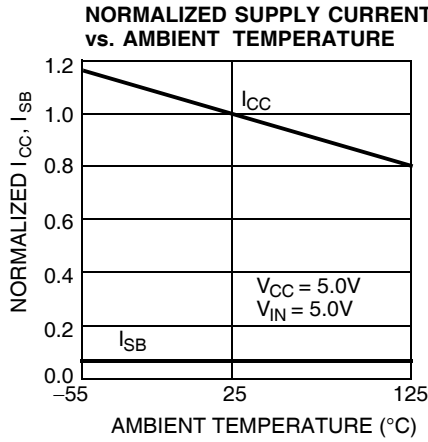
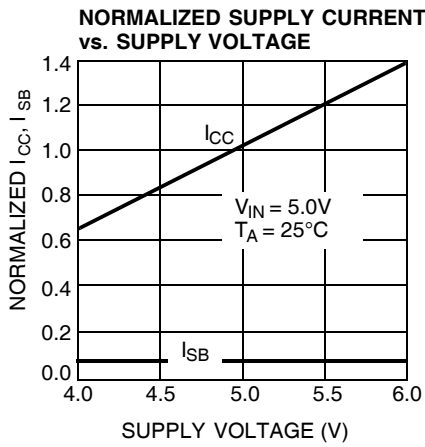

Ordering Information

Speed (ns)	Ordering Code	Package Name	Package Type	Operating Range
20	CY7C168A-20PXC	P5	20-Lead Molded DIP	Commercial

Ordering Code Definitions

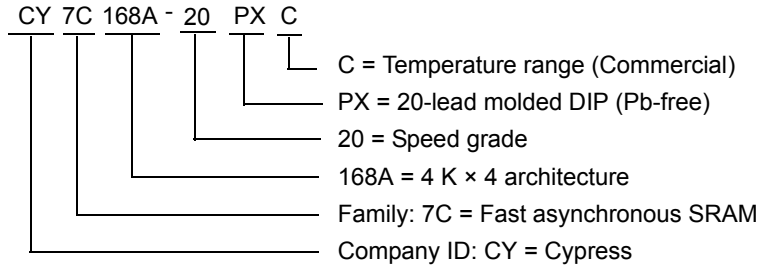

Package Diagram

Figure 6. 20-Lead (300-Mil) Molded DIP P5

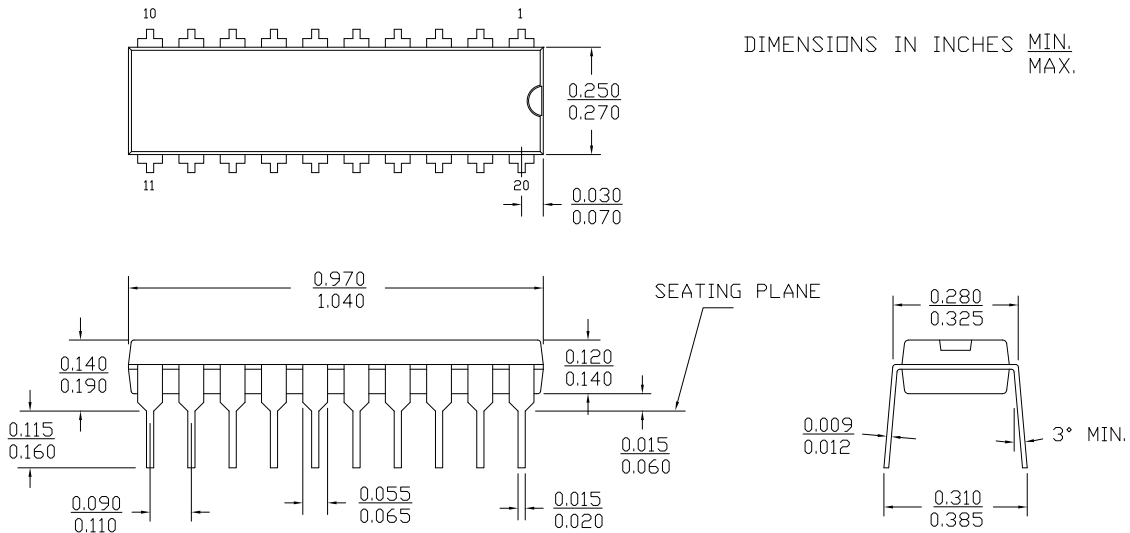

51-85011 *B

Acronyms

Acronym	Description
CMOS	complementary metal oxide semiconductor
CE	chip enable
DIP	dual inline package
I/O	input/output
SRAM	static random access memory
TTL	transistor-transistor logic
WE	write enable

Document Conventions

Units of Measure

Symbol	Unit of Measure
ns	nano seconds
V	Volts
μA	micro Amperes
mA	milli Amperes
mV	milli Volts
mW	milli Watts
pF	pico Farad
°C	degree Celcius
W	Watts
%	percent

Document History Page

Document Title: CY7C168A 4 K × 4 RAM Document Number: 38-05029				
REV.	ECN NO.	Issue Date	Orig. of Change	Description of Change
**	106815	09/10/01	SZV	Change from Spec number: 38-00095 to 38-05029
*A	3008799	08/19/2010	AJU	Updated t_{AA} to 20 ns under High Speed, 495 mW under Low active power in Features section Updated Figure caption to DIP Top View in Pin Configuration section Updated Selection Guide section with only 7C168A-20 values Updated Operating Range section with only Commercial temperature range Updated Electrical Characteristics section with only 7C168A-20 values Updated Switching Characteristics section with only 7C168A-20 values Updated Ordering Information section with only CY7C168A-20PXC Ordering Code Updated Package Diagram with only the latest revision of "20-Lead (300-Mil) Molded DIP P5" (Figure 6 in page 8) Minor edits and updated in new template
*B	3090588	11/19/2010	AJU	Post to external web.
*C	3097955	11/30/2010	PRAS	No technical updates. Sunset review.

Sales, Solutions, and Legal Information

Worldwide Sales and Design Support

Cypress maintains a worldwide network of offices, solution centers, manufacturer’s representatives, and distributors. To find the office closest to you, visit us at [Cypress Locations](#).

Products

Automotive	cypress.com/go/automotive
Clocks & Buffers	cypress.com/go/clocks
Interface	cypress.com/go/interface
Lighting & Power Control	cypress.com/go/powerpsoc cypress.com/go/plc
Memory	cypress.com/go/memory
Optical & Image Sensing	cypress.com/go/image
PSoC	cypress.com/go/psoc
Touch Sensing	cypress.com/go/touch
USB Controllers	cypress.com/go/USB
Wireless/RF	cypress.com/go/wireless

PSoC Solutions

psoc.cypress.com/solutions
PSoC 1 | PSoC 3 | PSoC 5

© Cypress Semiconductor Corporation, 2001-2010. The information contained herein is subject to change without notice. Cypress Semiconductor Corporation assumes no responsibility for the use of any circuitry other than circuitry embodied in a Cypress product. Nor does it convey or imply any license under patent or other rights. Cypress products are not warranted nor intended to be used for medical, life support, life saving, critical control or safety applications, unless pursuant to an express written agreement with Cypress. Furthermore, Cypress does not authorize its products for use as critical components in life-support systems where a malfunction or failure may reasonably be expected to result in significant injury to the user. The inclusion of Cypress products in life-support systems application implies that the manufacturer assumes all risk of such use and in doing so indemnifies Cypress against all charges.



Any Source Code (software and/or firmware) is owned by Cypress Semiconductor Corporation (Cypress) and is protected by and subject to worldwide patent protection (United States and foreign), United States copyright laws and international treaty provisions. Cypress hereby grants to licensee a personal, non-exclusive, non-transferable license to copy, use, modify, create derivative works of, and compile the Cypress Source Code and derivative works for the sole purpose of creating custom software and or firmware in support of licensee product to be used only in conjunction with a Cypress integrated circuit as specified in the applicable agreement. Any reproduction, modification, translation, compilation, or representation of this Source Code except as specified above is prohibited without the express written permission of Cypress.

Disclaimer: CYPRESS MAKES NO WARRANTY OF ANY KIND, EXPRESS OR IMPLIED, WITH REGARD TO THIS MATERIAL, INCLUDING, BUT NOT LIMITED TO, THE IMPLIED WARRANTIES OF MERCHANTABILITY AND FITNESS FOR A PARTICULAR PURPOSE. Cypress reserves the right to make changes without further notice to the materials described herein. Cypress does not assume any liability arising out of the application or use of any product or circuit described herein. Cypress does not authorize its products for use as critical components in life-support systems where a malfunction or failure may reasonably be expected to result in significant injury to the user. The inclusion of Cypress’ product in a life-support systems application implies that the manufacturer assumes all risk of such use and in doing so indemnifies Cypress against all charges.

Use may be limited by and subject to the applicable Cypress software license agreement.

Looking for pricing, stock, or lifecycle information?

Click below to explore more details on WIN SOURCE:

-  [View CY7C168A-20PXC on WIN SOURCE](#)
-  [Cypress Semiconductor Corp Information](#)

Optimize Your Supply Chain with WIN SOURCE Solutions

-  Global Sourcing Solution
-  Obsolete Management
-  Cost Control Management
-  Shortage Management
-  Alternative Solution
-  Excess Inventory Management