



# THE DATASHEET OF ATMEGA161-8PI

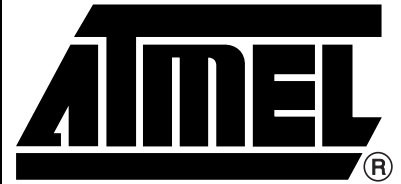


## Features

- High-performance, Low-power AVR<sup>®</sup> 8-bit Microcontroller
- Advanced RISC Architecture
  - 130 Powerful Instructions – Most Single Clock Cycle Execution
  - 32 x 8 General Purpose Working Registers
  - Fully Static Operation
  - Up to 8 MIPS Throughput at 8 MHz
  - On-chip 2-cycle Multiplier
- Program and Data Memories
  - 16K Bytes of Non-volatile In-System Programmable Flash Endurance: 1,000 Write/Erase Cycles
  - Optional Boot Code Memory with Independent Lock bits Self-programming of Program and Data Memories
  - 512 Bytes of Non-volatile In-System Programmable EEPROM Endurance: 100,000 Write/Erase Cycles
  - 1K Byte of Internal SRAM
  - Programming Lock for Software Security
- Peripheral Features
  - Two 8-bit Timer/Counters with Separate Prescaler and PWM
  - Expanded 16-bit Timer/Counter System with Separate Prescaler, Compare, Capture Modes and Dual 8-, 9-, or 10-bit PWM
  - Dual Programmable Serial UARTs
  - Master/Slave SPI Serial Interface
  - Real-time Counter with Separate Oscillator
  - Programmable Watchdog Timer with Separate On-chip Oscillator
  - On-chip Analog Comparator
- Special Microcontroller Features
  - Power-on Reset
  - External and Internal Interrupt Sources
  - Three Sleep Modes: Idle, Power-save and Power-down
- Power Consumption at 4 MHz, 3.0V, 25°C
  - Active 3.0 mA
  - Idle Mode 1.2 mA
  - Power-down Mode < 1 µA
- I/O and Packages
  - 35 Programmable I/O Lines
  - 40-lead PDIP and 44-lead TQFP
- Operating Voltages
  - 2.7V - 5.5V for the ATmega161L
  - 4.0V - 5.5V for the ATmega161
- Speed Grades
  - 0 - 4 MHz for the ATmega161L
  - 0 - 8 MHz for the ATmega161
- Commercial and Industrial Temperature Ranges

## Disclaimer

Typical values contained in this data sheet are based on simulations and characterization of other AVR microcontrollers manufactured on the same process technology. Min and Max values will be available after the device is characterized.



**8-bit AVR<sup>®</sup>  
Microcontroller  
with 16K Bytes  
of In-System  
Programmable  
Flash**

**ATmega161  
ATmega161L**

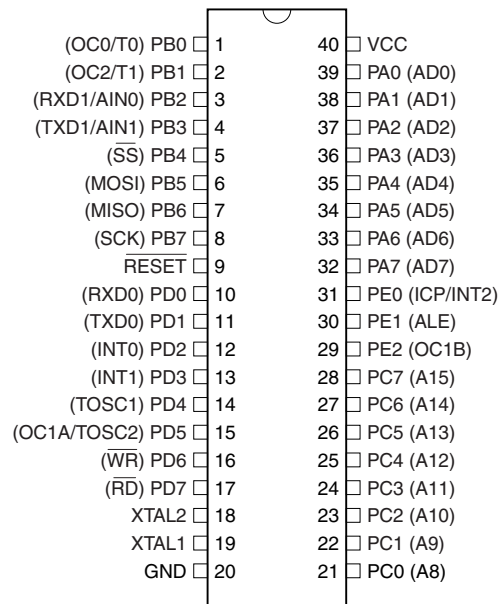
Note: Not recommended in new designs.

Rev. 1228D-AVR-02/07

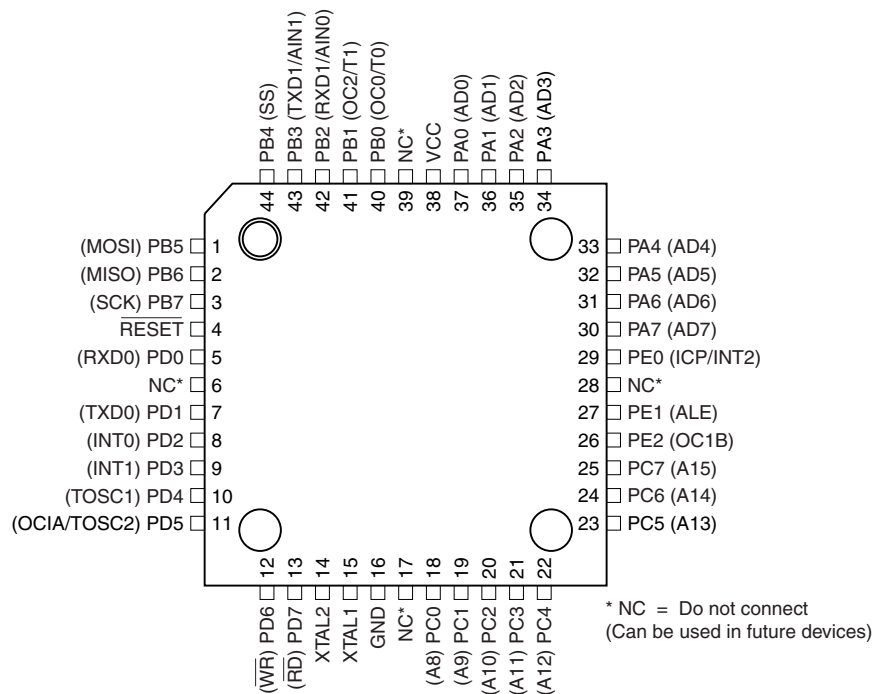


# Pin Configuration

PDIP



TQFP



## Description

The ATmega161 is a low-power CMOS 8-bit microcontroller based on the AVR RISC architecture. By executing powerful instructions in a single clock cycle, the ATmega161 achieves throughputs approaching 1 MIPS per MHz allowing the system designer to optimize power consumption versus processing speed. The AVR core combines a rich instruction set with 32 general purpose working registers. All the 32 registers are directly connected to the Arithmetic Logic Unit (ALU), allowing two independent registers to be accessed in one single instruction executed in one clock cycle. The resulting architecture is more code-efficient while achieving throughputs up to ten times faster than conventional CISC microcontrollers.

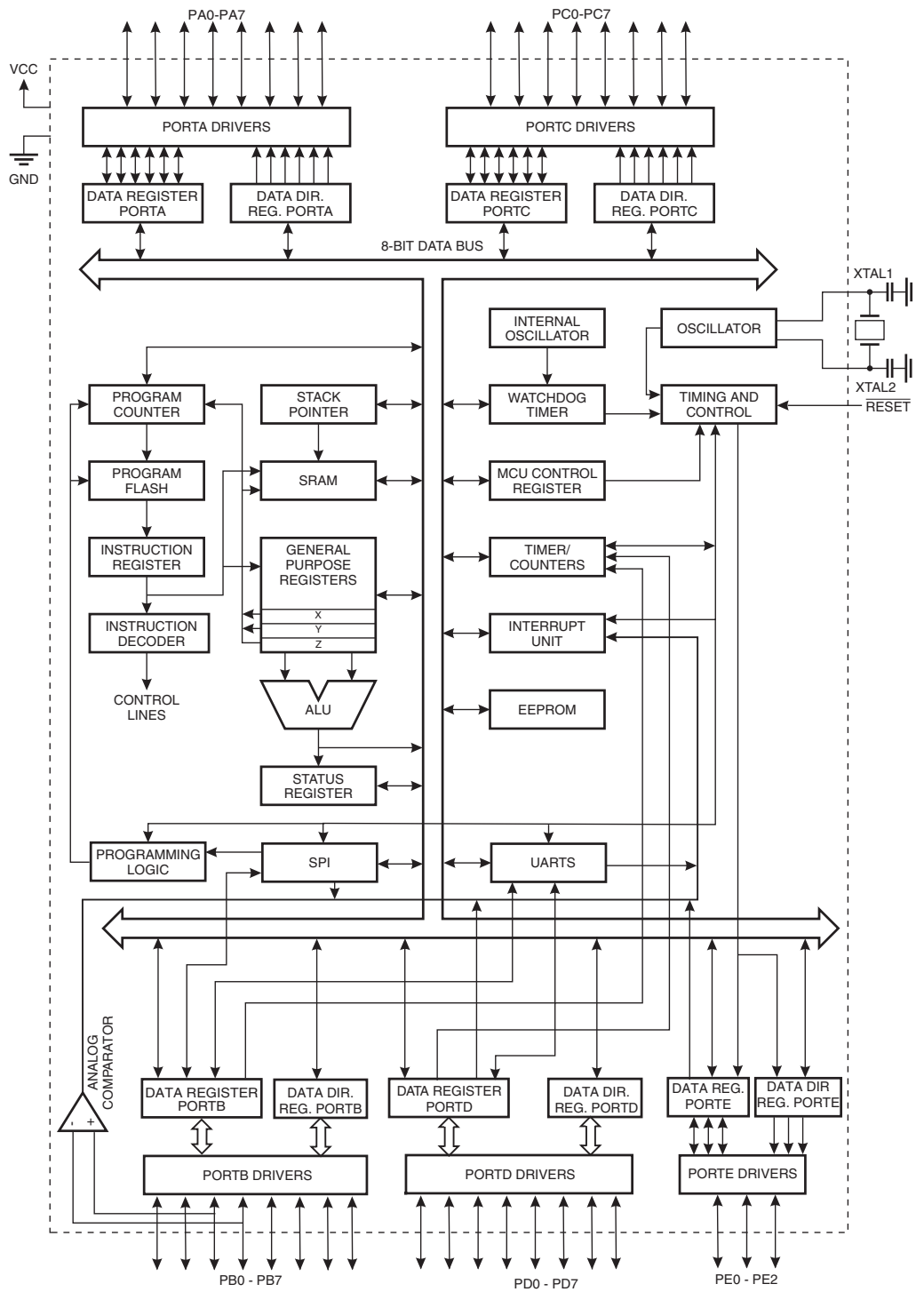
The ATmega161 provides the following features: 16K bytes of In-System or Self-programmable Flash, 512 bytes EEPROM, 1K byte of SRAM, 35 general purpose I/O lines, 32 general purpose working registers, Real-time Counter, three flexible Timer/Counters with Compare modes, internal and external interrupts, two programmable serial UARTs, programmable Watchdog Timer with internal Oscillator, an SPI serial port and three software-selectable power saving modes. The Idle mode stops the CPU while allowing the SRAM, Timer/Counters, SPI port and interrupt system to continue functioning. The Power-down mode saves the register and SRAM contents but freezes the Oscillator, disabling all other chip functions until the next External Interrupt or Hardware Reset. In Power-save mode, the timer Oscillator continues to run, allowing the user to maintain a timer base while the rest of the device is sleeping.

The device is manufactured using Atmel's high-density non-volatile memory technology. The On-chip Flash Program memory can be reprogrammed using the Self-programming capability through the Boot Block and an ISP through the SPI port, or by using a conventional non-volatile Memory programmer. By combining an enhanced RISC 8-bit CPU with In-System Programmable Flash on a monolithic chip, the Atmel ATmega161 is a powerful microcontroller that provides a highly flexible and cost-effective solution to many embedded control applications.

The ATmega161 AVR is supported with a full suite of program and system development tools including: C compilers, macro assemblers, program debugger/simulators, In-Circuit Emulators and evaluation kits.

# Block Diagram

Figure 1. The ATmega161 Block Diagram



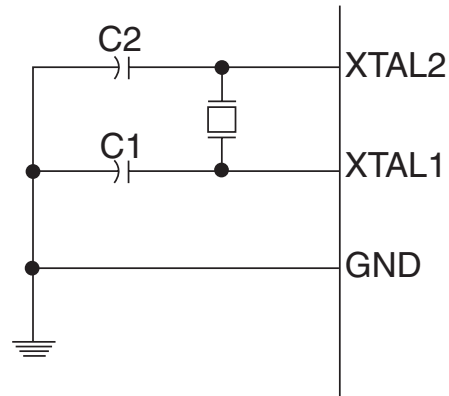
**Pin Descriptions**

<b>VCC</b>	Supply voltage.
<b>GND</b>	Ground.
<b>Port A (PA7..PA0)</b>	<p>Port A is an 8-bit bi-directional I/O port. Port pins can provide internal pull-up resistors (selected for each bit). The Port A output buffers can sink 20 mA and can drive LED displays directly. When pins PA0 to PA7 are used as inputs and are externally pulled low, they will source current if the internal pull-up resistors are activated. The Port A pins are tri-stated when a reset condition becomes active, even if the clock is not running.</p> <p>Port A serves as a Multiplexed Address/Data port when using external memory interface.</p>
<b>Port B (PB7..PB0)</b>	<p>Port B is an 8-bit bi-directional I/O port with internal pull-up resistors. The Port B output buffers can sink 20 mA. As inputs, Port B pins that are externally pulled low will source current if the pull-up resistors are activated. The Port B pins are tri-stated when a reset condition becomes active, even if the clock is not running.</p> <p>Port B also serves the functions of various special features of the ATmega161 as listed on page 92.</p>
<b>Port C (PC7..PC0)</b>	<p>Port C is an 8-bit bi-directional I/O port with internal pull-up resistors. The Port C output buffers can sink 20 mA. As inputs, Port C pins that are externally pulled low will source current if the pull-up resistors are activated. The Port C pins are tri-stated when a reset condition becomes active, even if the clock is not running.</p> <p>Port C also serves as an address high output when using external memory interface.</p>
<b>Port D (PD7..PD0)</b>	<p>Port D is an 8-bit bi-directional I/O port with internal pull-up resistors. The Port D output buffers can sink 20 mA. As inputs, Port D pins that are externally pulled low will source current if the pull-up resistors are activated. The Port D pins are tri-stated when a reset condition becomes active, even if the clock is not running.</p> <p>Port D also serves the functions of various special features of the ATmega161 as listed on page 101.</p>
<b>Port E (PE2..PE0)</b>	<p>Port E is a 3-bit bi-directional I/O port with internal pull-up resistors. The Port E output buffers can sink 20 mA. As inputs, Port E pins that are externally pulled low will source current if the pull-up resistors are activated. The Port E pins are tri-stated when a reset condition becomes active, even if the clock is not running.</p> <p>Port E also serves the functions of various special features of the ATmega161 as listed on page 107.</p>
<b>RESET</b>	Reset input. A low level on this pin for more than 500 ns will generate a Reset, even if the clock is not running. Shorter pulses are not guaranteed to generate a Reset.
<b>XTAL1</b>	Input to the inverting Oscillator amplifier and input to the internal clock operating circuit.
<b>XTAL2</b>	Output from the inverting Oscillator amplifier.

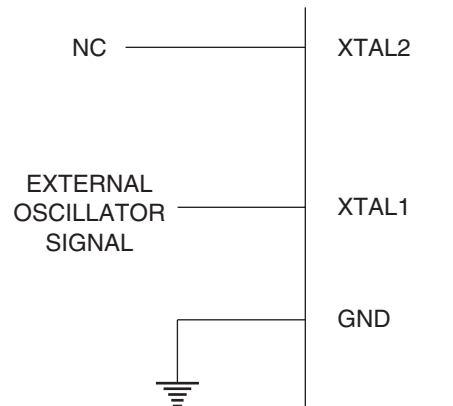
## Crystal Oscillator

XTAL1 and XTAL2 are input and output, respectively, of an inverting amplifier that can be configured for use as an on-chip Oscillator, as shown in Figure 2. Either a quartz crystal or a ceramic resonator may be used. To drive the device from an external clock source, XTAL2 should be left unconnected while XTAL1 is driven as shown in Figure 3.

**Figure 2.** Oscillator Connections



**Figure 3.** External Clock Drive Configuration



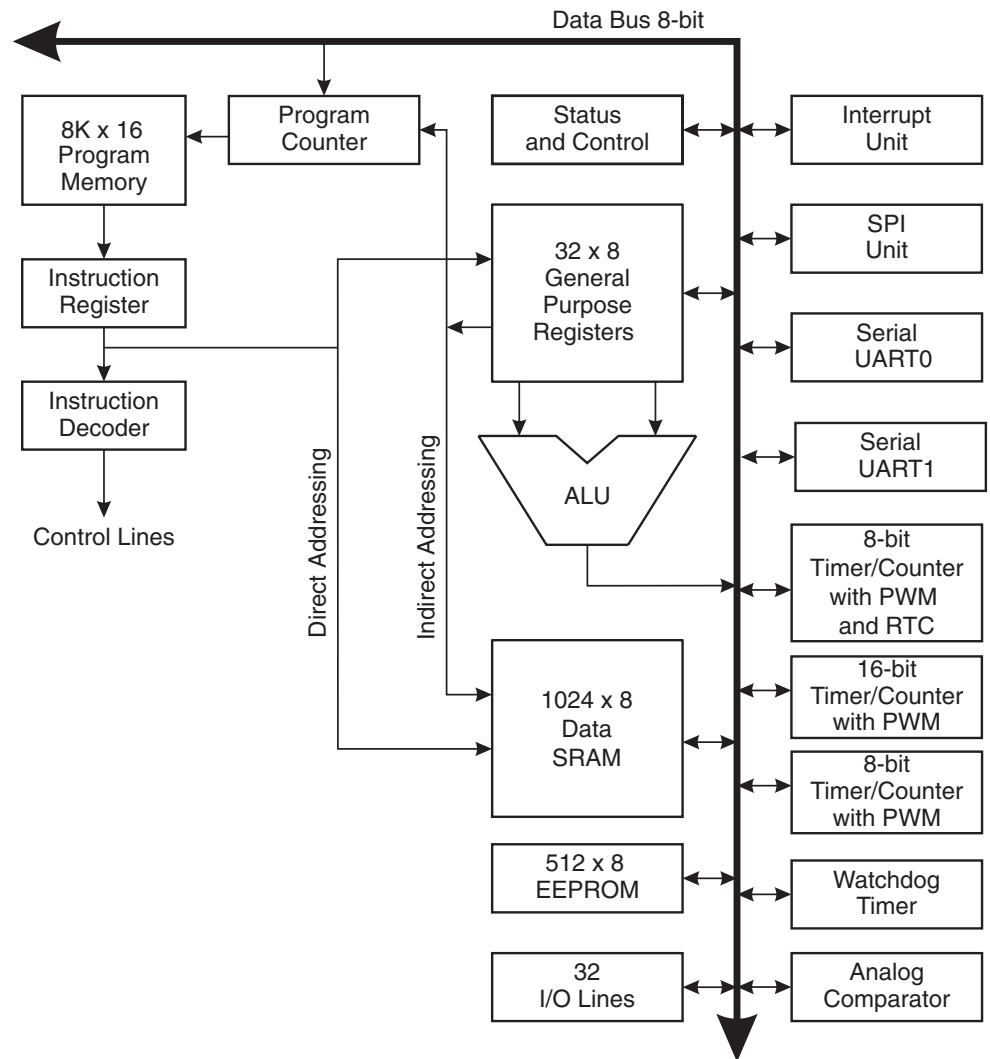
## Architectural Overview

The fast-access Register File concept contains 32 x 8-bit general purpose working registers with a single clock cycle access time. This means that during one single clock cycle, one Arithmetic Logic Unit (ALU) operation is executed. Two operands are output from the Register File, the operation is executed and the result is stored back in the Register File – in one clock cycle.

Six of the 32 registers can be used as three 16-bit indirect address register pointers for Data Space addressing – enabling efficient address calculations. One of the three address pointers is also used as the address pointer for the constant table look-up function. These added function registers are the 16-bit X-register, Y-register and Z-register.

The ALU supports arithmetic and logic functions between registers or between a constant and a register. Single register operations are also executed in the ALU. Figure 4 shows the ATmega161 AVR RISC microcontroller architecture.

**Figure 4.** The ATmega161 AVR RISC Architecture





In addition to the register operation, the conventional Memory Addressing modes can be used on the Register File. This is enabled by the fact that the Register File is assigned the 32 lowermost Data Space addresses (\$00 - \$1F), allowing them to be accessed as though they were ordinary memory locations.

The I/O memory space contains 64 addresses for CPU peripheral functions such as Control Registers, Timer/Counters, and other I/O functions. The I/O memory can be accessed directly or as the Data Space locations following those of the Register File, \$20 - \$5F.

The AVR uses a Harvard architecture concept – with separate memories and buses for program and data. The Program memory is executed with a two-stage pipeline. While one instruction is being executed, the next instruction is pre-fetched from the Program memory. This concept enables instructions to be executed in every clock cycle. The Program memory is Self-programmable Flash memory.

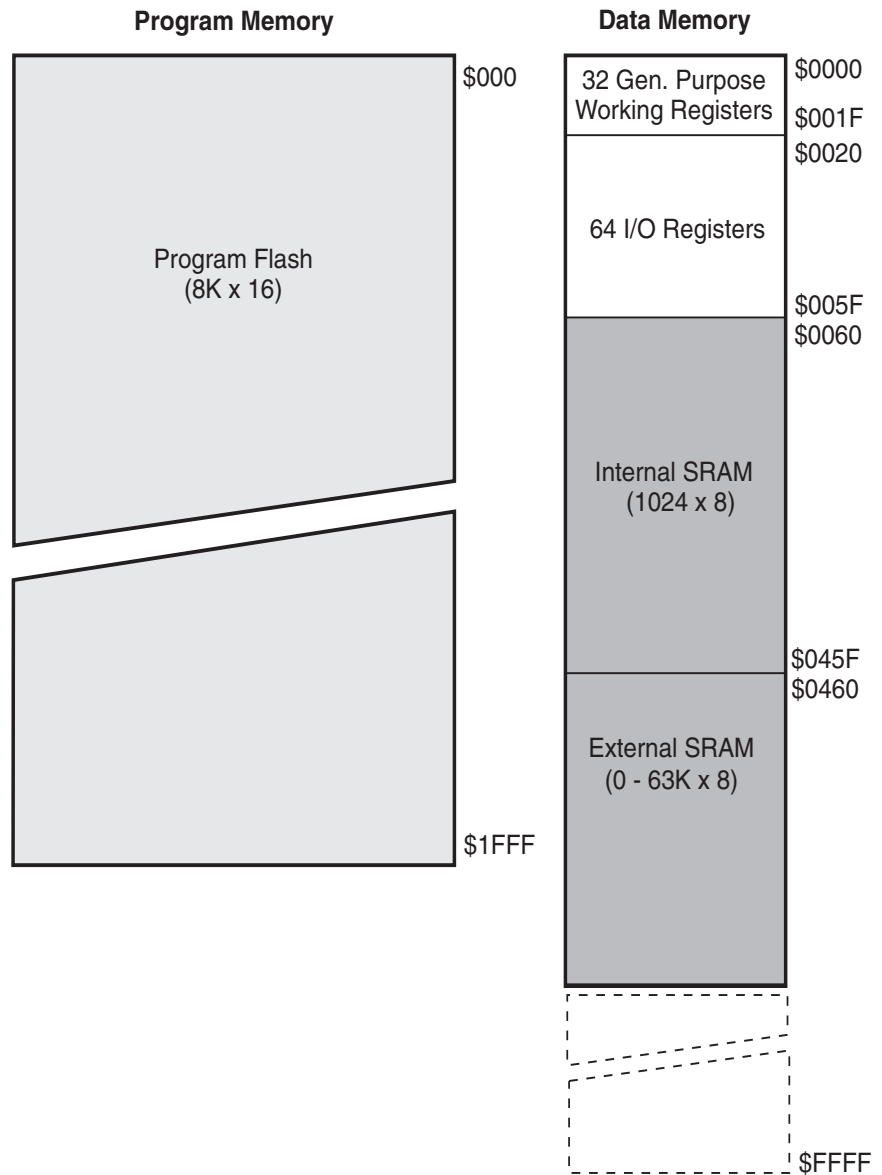
With the jump and call instructions, the whole 8K word address space is directly accessed. Most AVR instructions have a single 16-bit word format. Every Program memory address contains a 16- or 32-bit instruction.

During interrupts and subroutine calls, the return address Program Counter (PC) is stored on the Stack. The Stack is effectively allocated in the general data SRAM and, consequently, the Stack size is only limited by the total SRAM size and the usage of the SRAM. All user programs must initialize the SP (Stack Pointer) in the reset routine (before subroutines or interrupts are executed). The 16-bit Stack Pointer is read/write accessible in the I/O space.

The 1K byte data SRAM can be easily accessed through the five different Addressing modes supported in the AVR architecture.

The memory spaces in the AVR architecture are all linear and regular memory maps.

**Figure 5. Memory Maps**



A flexible interrupt module has its control registers in the I/O space with an additional global interrupt enable bit in the Status Register. All the different interrupts have a separate Interrupt Vector in the Interrupt Vector table at the beginning of the Program memory. The different interrupts have priority in accordance with their Interrupt Vector position. The lower the Interrupt Vector address, the higher the priority.

## The General Purpose Register File

Figure 6 shows the structure of the 32 general purpose working registers in the CPU.

**Figure 6.** AVR CPU General Purpose Working Registers

	7	0	Addr.	
General Purpose Working Registers	R0		\$00	
	R1		\$01	
	R2		\$02	
	...			
	R13		\$0D	
	R14		\$0E	
	R15		\$0F	
	R16		\$10	
	R17		\$11	
	...			
	R26		\$1A	X-register Low Byte
	R27		\$1B	X-register High Byte
	R28		\$1C	Y-register Low Byte
	R29		\$1D	Y-register High Byte
	R30		\$1E	Z-register Low Byte
	R31		\$1F	Z-register High Byte

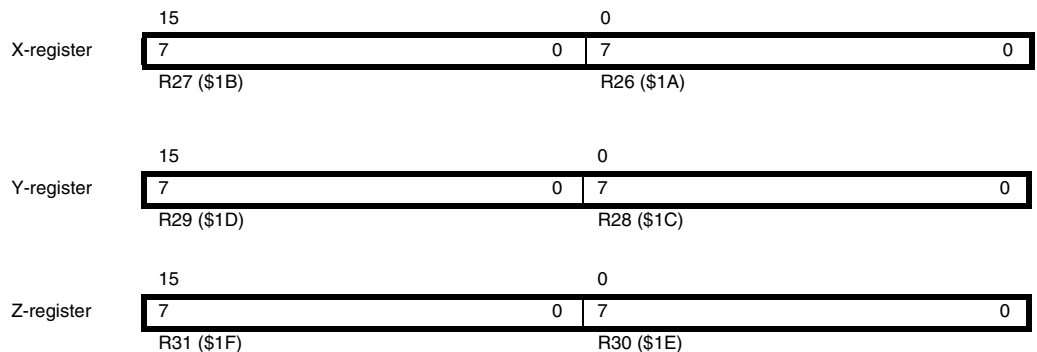
All the register operating instructions in the instruction set have direct and single cycle access to all registers. The only exceptions are the five constant arithmetic and logic instructions SBCI, SUBI, CPI, ANDI, and ORI between a constant and a register, and the LDI instruction for load immediate constant data. These instructions apply to the second half of the registers in the Register File – R16..R31. The general SBC, SUB, CP, AND, and OR, and all other operations between two registers or on a single register apply to the entire Register File.

As shown in Figure 6, each register is also assigned a Data memory address, mapping them directly into the first 32 locations of the user Data Space. Although not being physically implemented as SRAM locations, this memory organization provides great flexibility in access of the registers, as the X-, Y-, and Z-registers can be set to index any register in the file.

### The X-register, Y-register and Z-register

The registers R26..R31 have some added functions to their general purpose usage. These registers are address pointers for indirect addressing of the Data Space. The three indirect address registers X, Y, and Z are defined as:

**Figure 7.** X-, Y-, and Z-registers



In the different Addressing modes, these address registers have functions as fixed displacement, automatic increment and decrement (see the descriptions for the different instructions).

## **ALU – Arithmetic Logic Unit**

The high-performance AVR ALU operates in direct connection with all the 32 general purpose working registers. Within a single clock cycle, ALU operations between registers in the Register File are executed. The ALU operations are divided into three main categories – arithmetic, logical and bit functions. ATmega161 also provides a powerful multiplier supporting both signed/unsigned multiplication and fractional format. See the Instruction Set section for a detailed description.

## **Self-programmable Flash Program Memory**

The ATmega161 contains 16K bytes of On-chip Self-programmable and In-System Programmable Flash memory for program storage. Since all instructions are 16- or 32-bit words, the Flash is organized as 8K x 16. The Flash memory has an endurance of at least 1,000 write/erase cycles. The ATmega161 Program Counter (PC) is 13 bits wide, thus addressing the 8,192 Program memory locations.

See page 110 for a detailed description of Flash data downloading.

See page 13 for the different Program Memory Addressing modes.

## **EEPROM Data Memory**

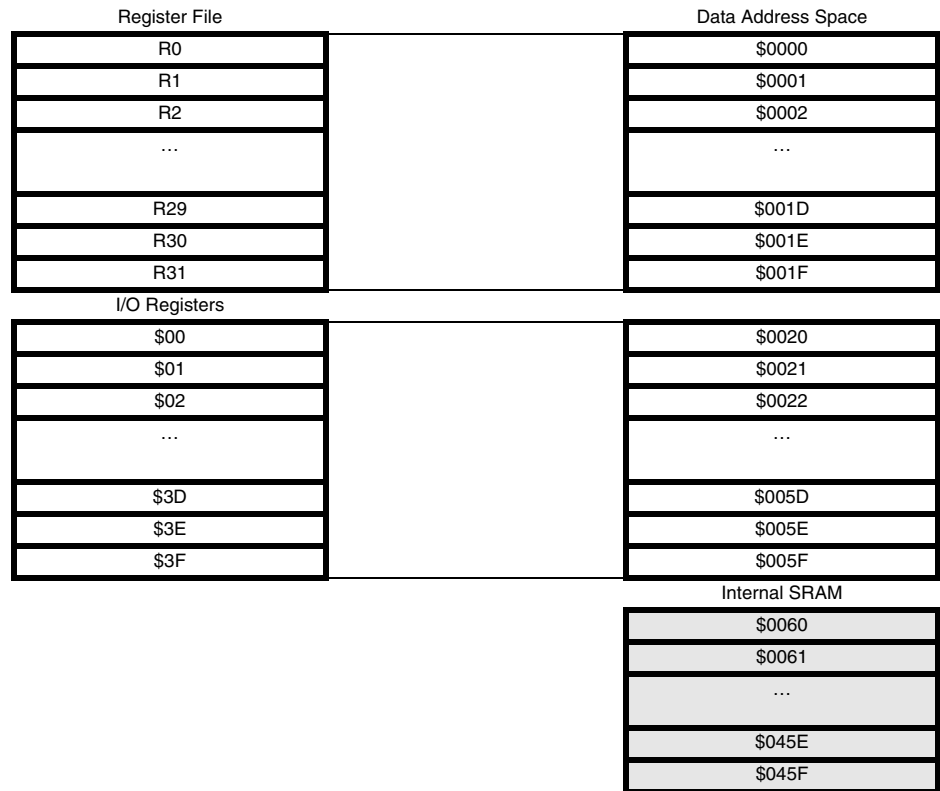
The ATmega161 contains 512 bytes of data EEPROM memory. It is organized as a separate data space in which single bytes can be read and written. The EEPROM has an endurance of at least 100,000 write/erase cycles per location. The interface between the EEPROM and the CPU is described on page 60, specifying the EEPROM Address Registers, the EEPROM Data Register and the EEPROM Control Register.

For the SPI data downloading, see page 125 for a detailed description.

## SRAM Data Memory

Figure 8 shows how the ATmega161 SRAM memory is organized.

**Figure 8.** SRAM Organization



The lower 1120 Data memory locations address the Register File, the I/O memory and the internal data SRAM. The first 96 locations address the Register File and I/O memory and the next 1K locations address the internal data SRAM. An optional external Data memory device can be placed in the same SRAM memory space. This memory device will occupy the locations following the internal SRAM and up to as much as 64K - 1, depending on external memory size.

When the addresses accessing the Data memory space exceed the internal data SRAM locations, the memory device is accessed using the same instructions as for the internal data SRAM access. When the internal data space is accessed, the read and write strobe pins ( $\overline{RD}$  and  $\overline{WR}$ ) are inactive during the whole access cycle. External memory operation is enabled by setting the SRE bit in the MCUCR Register. See "Interface to External Memory" on page 84 for details.

Accessing external memory takes one additional clock cycle per byte compared to access of the internal SRAM. This means that the commands LD, ST, LDS, STS, PUSH, and POP take one additional clock cycle. If the Stack is placed in external memory, interrupts, subroutine calls and returns take two clock cycles extra because the 2-byte Program Counter is pushed and popped. When external memory interface is used with wait state, two additional clock cycles are used per byte. This has the following effect: Data transfer instructions take two extra clock cycles, whereas interrupt, subroutine calls and returns will need four clock cycles more than specified in the Instruction Set manual.

The five different Addressing modes for the Data memory cover: Direct, Indirect with Displacement, Indirect, Indirect with Pre-decrement and Indirect with Post-increment. In the Register File, registers R26 to R31 feature the indirect Addressing Pointer Registers.

The direct addressing reaches the entire data space.

The Indirect with Displacement mode features a 63-address locations reach from the base address given by the Y- or Z-register.

When using Register Indirect Addressing modes with automatic pre-decrement and post-increment, the address registers X, Y, and Z are decremented and incremented.

The 32 general purpose working registers, 64 I/O Registers and the 1K byte of internal data SRAM in the ATmega161 are all accessible through all these Addressing modes.

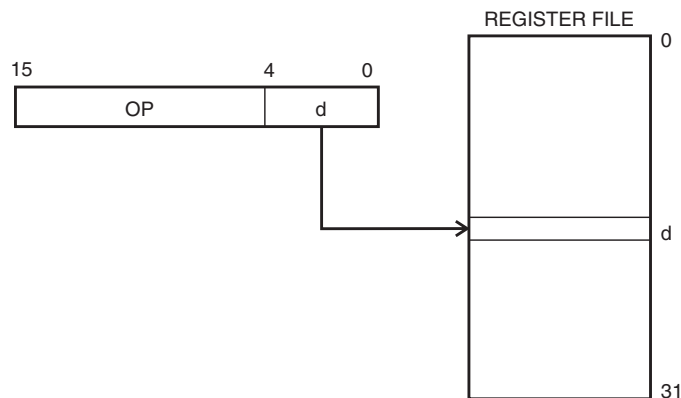
See the next section for a detailed description of the different Addressing modes.

## Program and Data Addressing Modes

The ATmega161 AVR RISC microcontroller supports powerful and efficient Addressing modes for access to the Program memory (Flash) and Data memory (SRAM, Register File and I/O memory). This section describes the different Addressing modes supported by the AVR architecture. In the figures, OP means the operation code part of the instruction word. To simplify, not all figures show the exact location of the addressing bits.

### Register Direct, Single Register Rd

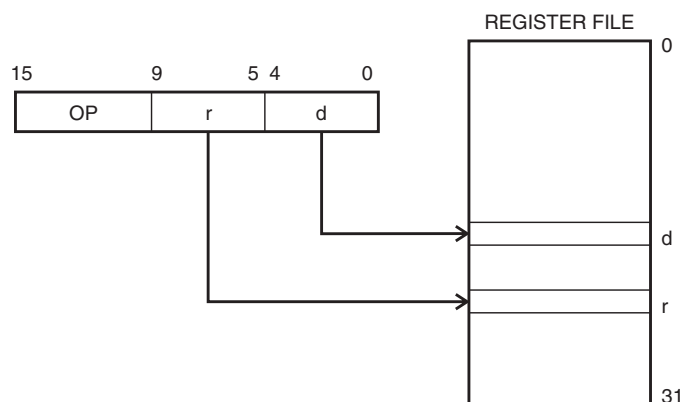
**Figure 9.** Direct Single Register Addressing



The operand is contained in register d (Rd).

### Register Direct, Two Registers Rd and Rr

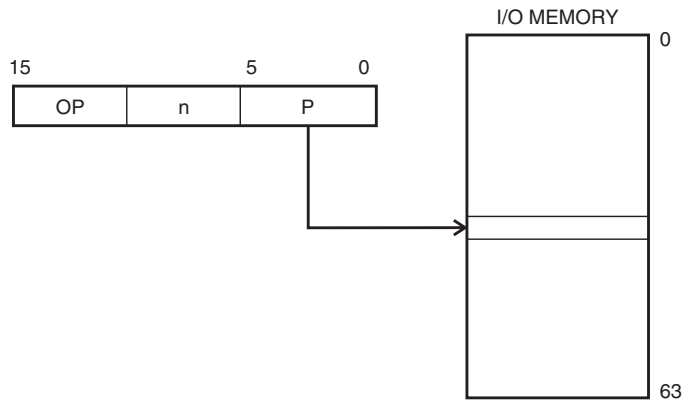
**Figure 10.** Direct Register Addressing, Two Registers



Operands are contained in registers r (Rr) and d (Rd). The result is stored in register d (Rd).

**I/O Direct**

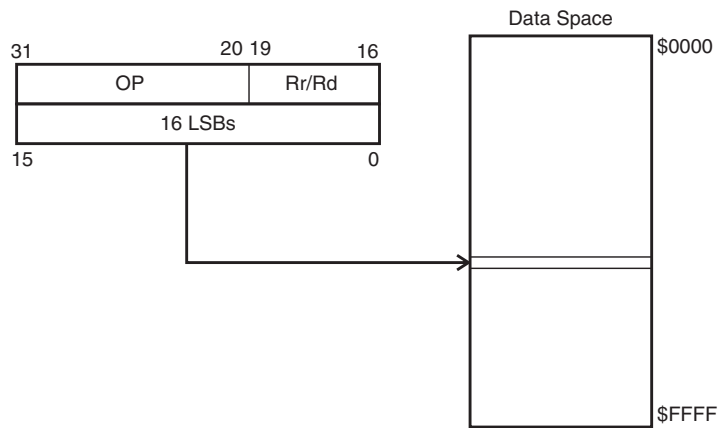
**Figure 11.** I/O Direct Addressing



Operand address is contained in six bits of the instruction word. n is the destination or Source Register Address.

**Data Direct**

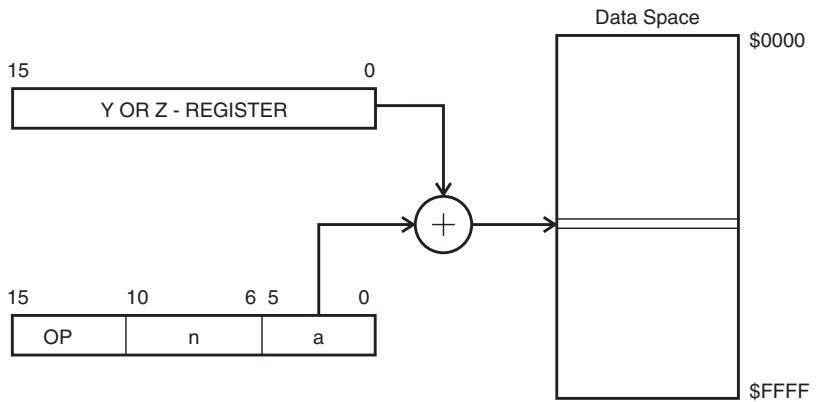
**Figure 12.** Direct Data Addressing



A 16-bit data address is contained in the 16 LSBs of a two-word instruction. Rd/Rr specify the destination or source register.

## Data Indirect with Displacement

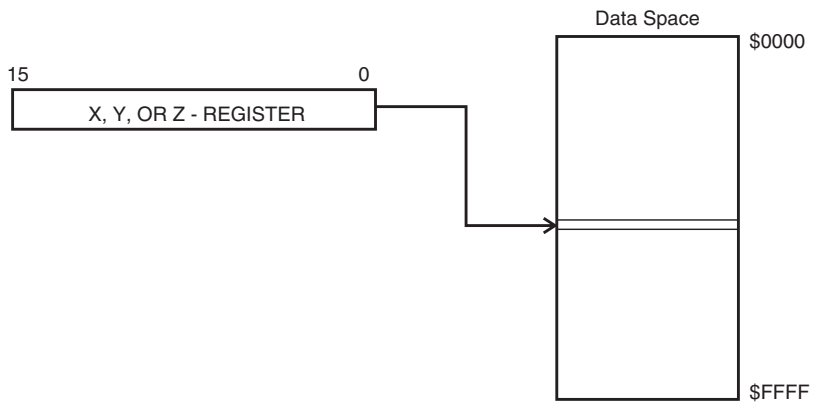
**Figure 13.** Data Indirect with Displacement



Operand address is the result of the Y- or Z-register contents added to the address contained in six bits of the instruction word.

## Data Indirect

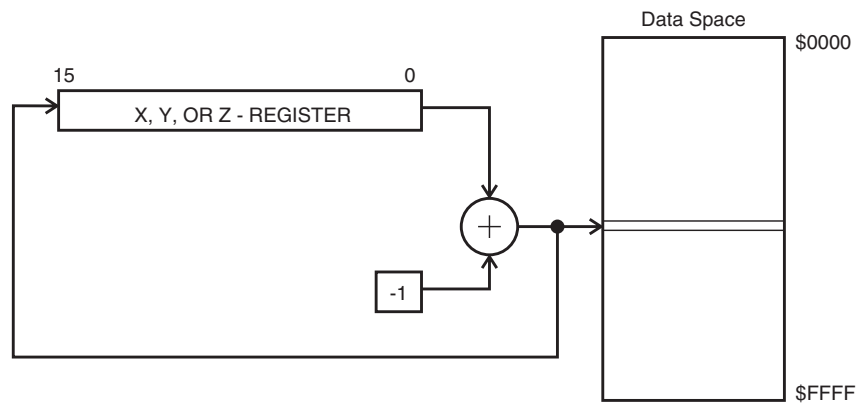
**Figure 14.** Data Indirect Addressing



Operand address is the contents of the X-, Y-, or Z-register.

## Data Indirect with Pre-decrement

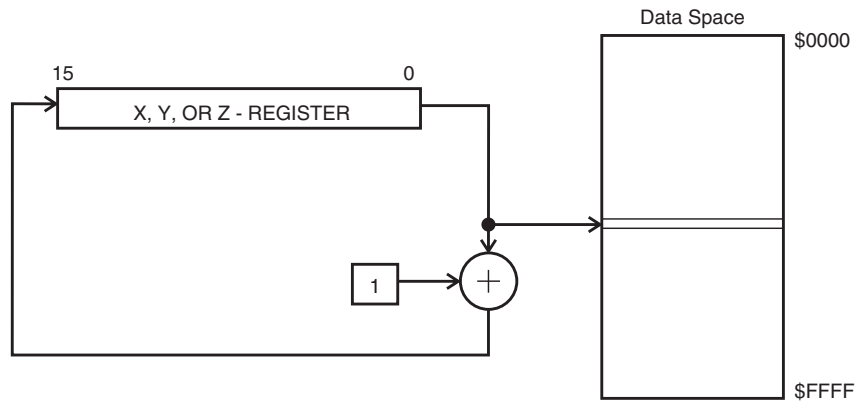
**Figure 15.** Data Indirect Addressing with Pre-decrement



The X-, Y-, or Z-register is decremented before the operation. Operand address is the decremented contents of the X-, Y-, or Z-register.

### Data Indirect with Post-increment

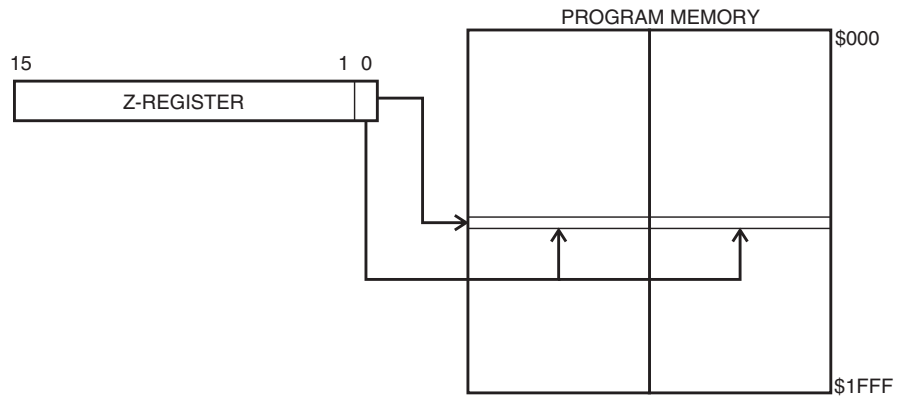
**Figure 16.** Data Indirect Addressing with Post-increment



The X-, Y-, or Z-register is incremented after the operation. Operand address is the contents of the X-, Y-, or Z-register prior to incrementing.

### Constant Addressing Using the LPM Instruction

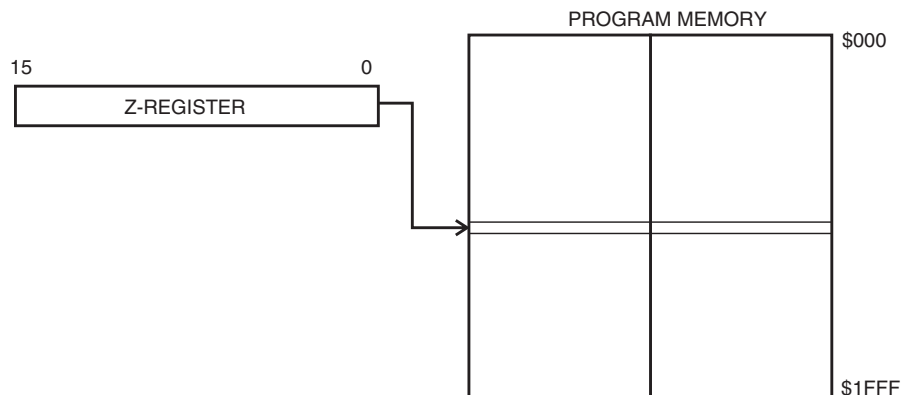
**Figure 17.** Code Memory Constant Addressing



Constant byte address is specified by the Z-register contents. The 15 MSBs select word address (0 - 8K), the LSB selects Low byte if cleared (LSB = 0) or High byte if set (LSB = 1).

### Indirect Program Addressing, IJMP and ICALL

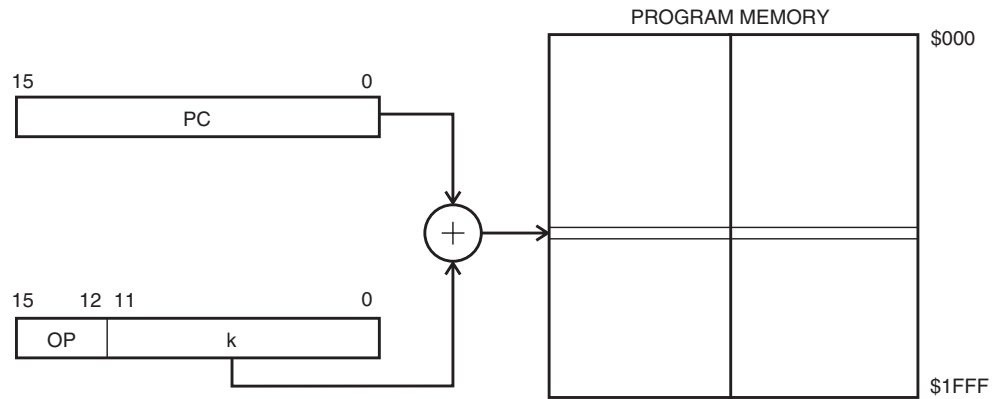
**Figure 18.** Indirect Program Memory Addressing



Program execution continues at address contained by the Z-register (i.e., the PC is loaded with the contents of the Z-register).

## Relative Program Addressing, RJMP and RCALL

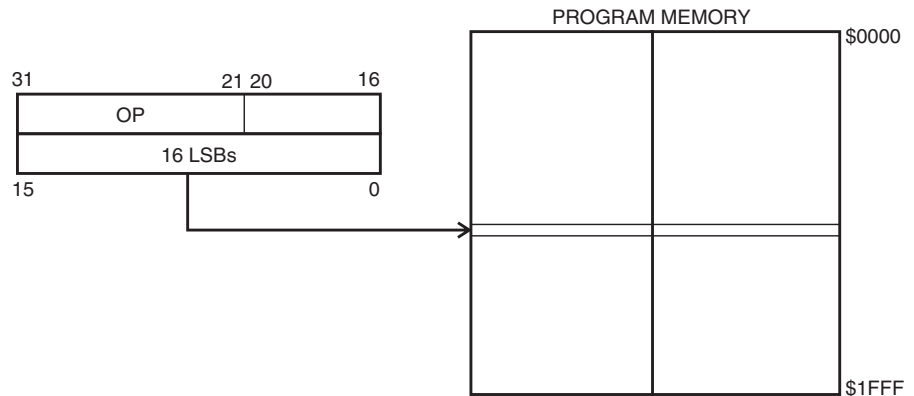
**Figure 19.** Relative Program Memory Addressing



Program execution continues at address  $PC + k + 1$ . The relative address  $k$  is -2048 to 2047.

## Direct Program Addressing, JMP and CALL

**Figure 20.** Direct Program Addressing



Program execution continues at the address immediate in the instruction words.

## Memory Access Times and Instruction Execution Timing

This section describes the general access timing concepts for instruction execution and internal memory access.

The AVR CPU is driven by the System Clock  $\emptyset$ , directly generated from the external clock crystal for the chip. No internal clock division is used.

Figure 21 shows the parallel instruction fetches and instruction executions enabled by the Harvard architecture and the fast-access Register File concept. This is the basic pipelining concept to obtain up to 1 MIPS per MHz with the corresponding unique results for functions per cost, functions per clocks and functions per power unit.

**Figure 21.** The Parallel Instruction Fetches and Instruction Executions

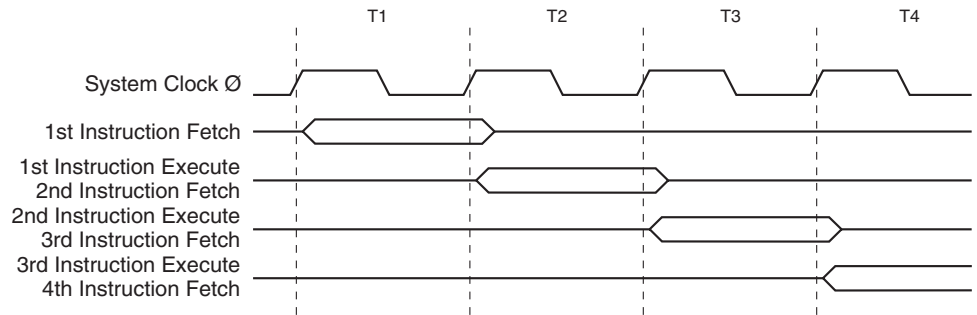
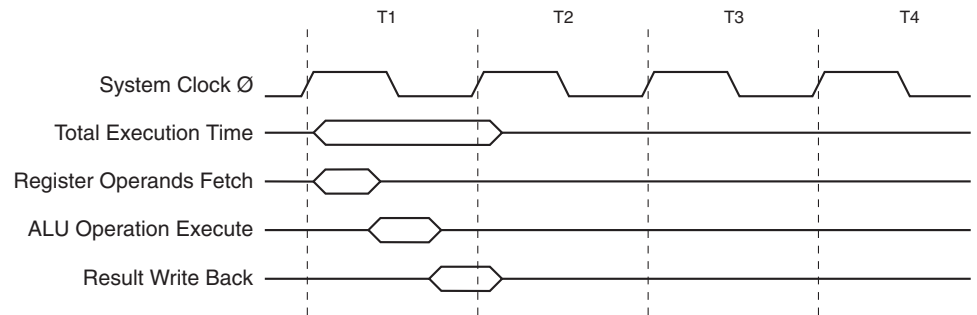


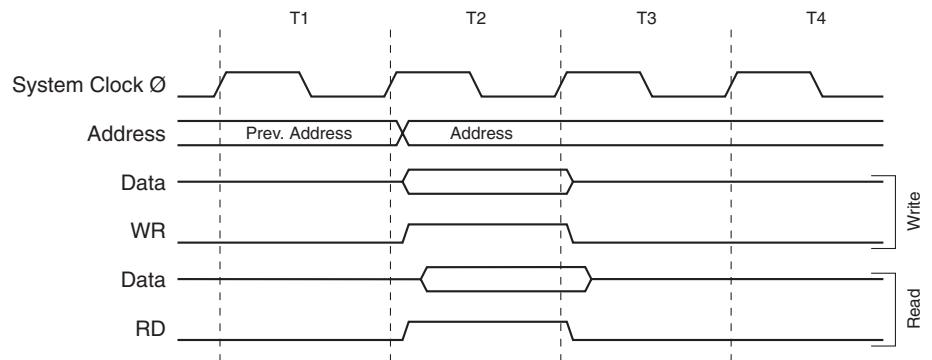
Figure 22 shows the internal timing concept for the Register File. In a single clock cycle an ALU operation using two register operands is executed and the result is stored back to the destination register.

**Figure 22.** Single Cycle ALU Operation



The internal data SRAM access is performed in two System Clock cycles as described in Figure 23.

**Figure 23.** On-chip Data SRAM Access Cycles



## I/O Memory

The I/O space definition of the ATmega161 is shown in Table 1.

**Table 1.** ATmega161 I/O Space<sup>(1)</sup>

I/O Address (SRAM Address)	Name	Function
\$3F (\$5F)	SREG	Status REGISTER
\$3E (\$5E)	SPH	Stack Pointer High
\$3D (\$5D)	SPL	Stack Pointer Low
\$3B (\$5B)	GIMSK	General Interrupt MaSK Register
\$3A (\$5A)	GIFR	General Interrupt Flag Register
\$39 (\$59)	TIMSK	Timer/Counter Interrupt MaSK Register
\$38 (\$58)	TIFR	Timer/Counter Interrupt Flag Register
\$37 (\$57)	SPMCR	Store Program Memory Control Register
\$36 (\$56)	EMCUCR	Extended MCU general Control Register
\$35 (\$55)	MCUCR	MCU general Control Register
\$34 (\$54)	MCUSR	MCU general Status Register
\$33 (\$53)	TCCR0	Timer/Counter0 Control Register
\$32 (\$52)	TCNT0	Timer/Counter0 (8-bit)
\$31 (\$51)	OCR0	Timer/Counter0 Output Compare Register
\$30 (\$50)	SFIOR	Special Function IO Register
\$2F (\$4F)	TCCR1A	Timer/Counter1 Control Register A
\$2E (\$4E)	TCCR1B	Timer/Counter1 Control Register B
\$2D (\$4D)	TCNT1H	Timer/Counter1 High Byte
\$2C (\$4C)	TCNT1L	Timer/Counter1 Low Byte
\$2B (\$4B)	OCR1AH	Timer/Counter1 Output Compare RegisterA High Byte
\$2A (\$4A)	OCR1AL	Timer/Counter1 Output Compare RegisterA Low Byte
\$29 (\$49)	OCR1BH	Timer/Counter1 Output Compare RegisterB High Byte
\$28 (\$48)	OCR1BL	Timer/Counter1 Output Compare RegisterB Low Byte
\$27 (\$47)	TCCR2	Timer/Counter2 Control Register
\$26 (\$46)	ASSR	Asynchronous mode Status Register
\$25 (\$45)	ICR1H	Timer/Counter1 Input Capture Register High Byte
\$24 (\$44)	ICR1L	Timer/Counter1 Input Capture Register Low Byte
\$23 (\$43)	TCNT2	Timer/Counter2 (8-bit)
\$22 (\$42)	OCR2	Timer/Counter2 Output Compare Register
\$21 (\$41)	WDTCR	Watchdog Timer Control Register
\$20 (\$40)	UBRRHI	UART Baud Register High
\$1F (\$3F)	EEARH	EEPROM Address Register High
\$1E (\$3E)	EEARL	EEPROM Address Register Low
\$1D (\$3D)	EEDR	EEPROM Data Register

**Table 1.** ATmega161 I/O Space<sup>(1)</sup> (Continued)

<b>I/O Address (SRAM Address)</b>	<b>Name</b>	<b>Function</b>
\$1C (\$3C)	EECR	EEPROM Control Register
\$1B(\$3B)	PORTA	Data Register, Port A
\$1A (\$3A)	DDRA	Data Direction Register, Port A
\$19 (\$39)	PINA	Input Pins, Port A
\$18 (\$38)	PORTB	Data Register, Port B
\$17 (\$37)	DDRB	Data Direction Register, Port B
\$16 (\$36)	PINB	Input Pins, Port B
\$15 (\$35)	PORTC	Data Register, Port C
\$14 (\$34)	DDRC	Data Direction Register, Port C
\$13 (\$33)	PINC	Input Pins, Port C
\$12 (\$32)	PORTD	Data Register, Port D
\$11 (\$31)	DDRD	Data Direction Register, Port D
\$10 (\$30)	PIND	Input Pins, Port D
\$0F (\$2F)	SPDR	SPI I/O Data Register
\$0E (\$2E)	SPSR	SPI Status Register
\$0D (\$2D)	SPCR	SPI Control Register
\$0C (\$2C)	UDR0	UART0 I/O Data Register
\$0B (\$2B)	UCSR0A	UART0 Control and Status Register
\$0A (\$2A)	UCSR0B	UART0 Control and Status Register
\$09 (\$29)	UBRR0	UART0 Baud Rate Register
\$08 (\$28)	ACSR	Analog Comparator Control and Status Register
\$07 (\$27)	PORTE	Data Register, Port E
\$06 (\$26)	DDRE	Data Direction Register, Port E
\$05 (\$25)	PINE	Input Pins, Port E
\$03 (\$23)	UDR1	UART1 I/O Data Register
\$02 (\$22)	UCSR1A	UART1 Control and Status Register
\$01 (\$21)	UCSR1B	UART1 Control and Status Register
\$00 (\$20)	UBRR1	UART1 Baud Rate Register

Note: 1. Reserved and unused locations are not shown in this table.

All ATmega161 I/Os and peripherals are placed in the I/O space. The I/O locations are accessed by the IN and OUT instructions transferring data between the 32 general purpose working registers and the I/O space. I/O Registers within the address range \$00 - \$1F are directly bit-accessible using the SBI and CBI instructions. In these registers, the value of single bits can be checked by using the SBIS and SBIC instructions. Refer to the instruction set section for more details. When using the I/O specific commands IN and OUT, the I/O addresses \$00 - \$3F must be used. When addressing I/O Registers as SRAM, \$20 must be added to this address. All I/O Register addresses throughout this document are shown with the SRAM address in parentheses.

For compatibility with future devices, reserved bits should be written to zero if accessed. Reserved I/O memory addresses should never be written.

Some of the Status Flags are cleared by writing a logical “1” to them. Note that the CBI and SBI instructions will operate on all bits in the I/O Register, writing a one back into any flag read as set, thus clearing the Flag. The CBI and SBI instructions work with registers \$00 to \$1F only.

The I/O and Peripherals Control Registers are explained in the following sections.

## Status Register – SREG

The AVR Status Register (SREG) at I/O space location \$3F (\$5F) is defined as:

Bit	7	6	5	4	3	2	1	0	
\$3F (\$5F)	I	T	H	S	V	N	Z	C	SREG
Read/Write	R/W	R/W	R/W	R/W	R/W	R/W	R/W	R/W	
Initial Value	0	0	0	0	0	0	0	0	

- **Bit 7 – I: Global Interrupt Enable**

The Global Interrupt Enable bit must be set (one) for the interrupts to be enabled. The individual interrupt enable control is then performed in separate control registers. If the Global Interrupt Enable bit is cleared (zero), none of the interrupts are enabled independent of the individual interrupt enable settings. The I-bit is cleared by hardware after an interrupt has occurred and is set by the RETI instruction to enable subsequent interrupts.

- **Bit 6 – T: Bit Copy Storage**

The Bit Copy instructions BLD (Bit LoaD) and BST (Bit STore) use the T-bit as source and destination for the operated bit. A bit from a register in the Register File can be copied into T by the BST instruction and a bit in T can be copied into a bit in a register in the Register File by the BLD instruction.

- **Bit 5 – H: Half Carry Flag**

The Half Carry Flag H indicates a Half Carry in some arithmetic operations. See the Instruction Set description for detailed information.

- **Bit 4 – S: Sign Bit,  $S = N \oplus V$**

The S-bit is always an exclusive or between the Negative Flag N and the Two’s Complement Overflow Flag V. See the Instruction Set description for detailed information.

- **Bit 3 – V: Two’s Complement Overflow Flag**

The Two’s Complement Overflow Flag V supports two’s complement arithmetics. See the Instruction Set Description for detailed information.

- **Bit 2 – N: Negative Flag**

The Negative Flag N indicates a negative result after the different arithmetic and logic operations. See the Instruction Set description for detailed information.

- **Bit 1 – Z: Zero Flag**

The Zero Flag Z indicates a zero result after the different arithmetic and logic operations. See the Instruction Set description for detailed information.

- **Bit 0 – C: Carry Flag**

The Carry Flag C indicates a carry in an arithmetic or logic operation. See the Instruction Set description for detailed information.

Note that the Status Register is not automatically stored when entering an interrupt routine and restored when returning from an interrupt routine. This must be handled by software.

## Stack Pointer – SP

The ATmega161 Stack Pointer is implemented as two 8-bit registers in the I/O space locations \$3E (\$5E) and \$3D (\$5D). As the ATmega161 supports up to 64-Kbyte memory, all 16 bits are used.

Bit	15	14	13	12	11	10	9	8	
\$3E (\$5E)	<b>SP15</b>	<b>SP14</b>	<b>SP13</b>	<b>SP12</b>	<b>SP11</b>	<b>SP10</b>	<b>SP9</b>	<b>SP8</b>	<b>SPH</b>
\$3D (\$5D)	<b>SP7</b>	<b>SP6</b>	<b>SP5</b>	<b>SP4</b>	<b>SP3</b>	<b>SP2</b>	<b>SP1</b>	<b>SP0</b>	<b>SPL</b>
	7	6	5	4	3	2	1	0	
Read/Write	R/W	R/W	R/W	R/W	R/W	R/W	R/W	R/W	
	R/W	R/W	R/W	R/W	R/W	R/W	R/W	R/W	
Initial Value	0	0	0	0	0	0	0	0	
	0	0	0	0	0	0	0	0	

The Stack Pointer points to the data SRAM Stack area where the Subroutine and Interrupt Stacks are located. This Stack space in the data SRAM must be defined by the program before any subroutine calls are executed or interrupts are enabled. The Stack Pointer must be set to point above \$60. The Stack Pointer is decremented by 1 when data is pushed onto the Stack with the PUSH instruction, and it is decremented by 2 when an address is pushed onto the Stack with subroutine calls and interrupts. The Stack Pointer is incremented by 1 when data is popped from the Stack with the POP instruction, and it is incremented by 2 when an address is popped from the Stack with return from subroutine RET or return from interrupt (RETI).

## Reset and Interrupt Handling

The ATmega161 provides 20 different interrupt sources. These interrupts and the separate Reset Vector each have a separate Program Vector in the Program memory space. All interrupts are assigned individual enable bits that must be set (one) together with the I-bit in the Status Register in order to enable the interrupt.

The lowest addresses in the Program memory space are automatically defined as the Reset and Interrupt vectors. The complete list of Vectors is shown in Table 2. The list also determines the priority levels of the different interrupts. The lower the address, the higher the priority level. RESET has the highest priority, and next is INTO (the External Interrupt Request 0) and so on.

**Table 2.** Reset and Interrupt Vectors<sup>(1)</sup>

Vector No.	Program Address	Source	Interrupt Definition
1	\$000	RESET	External Pin, Power-on Reset and Watchdog Reset
2	\$002	INT0	External Interrupt Request 0
3	\$004	INT1	External Interrupt Request 1
4	\$006	INT2	External Interrupt Request 2
5	\$008	TIMER2 COMP	Timer/Counter2 Compare Match
6	\$00a	TIMER2 OVF	Timer/Counter2 Overflow
7	\$00c	TIMER1 CAPT	Timer/Counter1 Capture Event
8	\$00e	TIMER1 COMPA	Timer/Counter1 Compare Match A
9	\$010	TIMER1 COMPB	Timer/Counter1 Compare Match B
10	\$012	TIMER1 OVF	Timer/Counter1 Overflow
11	\$014	TIMER0 COMP	Timer/Counter0 Compare Match
12	\$016	TIMER0 OVF	Timer/Counter0 Overflow
13	\$018	SPI, STC	Serial Transfer Complete
14	\$01a	UART0, RX	UART0, Rx Complete
15	\$01c	UART1, RX	UART1, Rx Complete
16	\$01e	UART0, UDRE	UART0 Data Register Empty
17	\$020	UART1, UDRE	UART1 Data Register Empty
18	\$022	UART0, TX	UART0, Tx Complete
19	\$024	UART1, TX	UART1, Tx Complete
20	\$026	EE_RDY	EEPROM Ready
21	\$028	ANA_COMP	Analog Comparator

Note: 1. If BOOTRST fuse is programmed, the Reset Vector is located on program address \$1e00, see Table 39 on page 112 for details.

The most typical and general program setup for the Reset and Interrupt Vector addresses are:

Address	Labels	Code	Comments
\$000		jmp RESET	; Reset Handler
\$002		jmp EXT_INT0	; IRQ0 Handler
\$004		jmp EXT_INT1	; IRQ1 Handler
\$006		jmp EXT_INT2	; IRQ2 Handler
\$008		jmp TIM2_COMP	; Timer2 Compare Handler
\$00a		jmp TIM2_OVF	; Timer2 Overflow Handler
\$00c		jmp TIM1_CAPT	; Timer1 Capture Handler
\$00e		jmp TIM1_COMPA	; Timer1 CompareA Handler
\$010		jmp TIM1_COMPB	; Timer1 CompareB Handler
\$012		jmp TIM1_OVF	; Timer1 Overflow Handler
\$014		jmp TIM0_COMP	; Timer0 Compare Handler
\$016		jmp TIM0_OVF	; Timer0 Overflow Handler
\$018		jmp SPI_STC;	; SPI Transfer Complete Handler

```

$01a      jmp     UART_RXC0    ; UART0 RX Complete Handler
$01c      jmp     UART_RXC1    ; UART1 RX Complete Handler
$01e      jmp     UART_DRE0    ; UDR0 Empty Handler
$020      jmp     UART_DRE1    ; UDR1 Empty Handler
$022      jmp     UART_TXC0    ; UART0 TX Complete Handler
$024      jmp     UART_TXC1    ; UART1 TX Complete Handler
$026      jmp     EE_RDY      ; EEPROM Ready Handler
$028      jmp     ANA_COMP     ; Analog Comparator Handler
;
$02a      MAIN:    ldi r16,high(RAMEND) ; Main program start
$02b      out     SPH,r16
$02c      ldi r16,low(RAMEND)
$02d      out     SPL,r16
$02e      <instr> xxx
...      ...      ...      ...

```

When the BOTRST fuse is programmed, the most typical and general program setup for the Reset and Interrupt Vector addresses are:

Address	Labels	Code	Comments
.org \$002			; Reset is located at \$1e000
\$002		jmp EXT_INT0	; IRQ0 Handler
\$004		jmp EXT_INT1	; IRQ1 Handler
\$006		jmp EXT_INT2	; IRQ2 Handler
\$008		jmp TIM2_COMP	; Timer2 Compare Handler
\$00a		jmp TIM2_OVF	; Timer2 Overflow Handler
\$00c		jmp TIM1_CAPT	; Timer1 Capture Handler
\$00e		jmp TIM1_COMPA	; Timer1 CompareA Handler
\$010		jmp TIM1_COMPB	; Timer1 CompareB Handler
\$012		jmp TIM1_OVF	; Timer1 Overflow Handler
\$014		jmp TIM0_COMP	; Timer0 Compare Handler
\$016		jmp TIM0_OVF	; Timer0 Overflow Handler
\$018		jmp SPI_STC;	; SPI Transfer Complete Handler
\$01a		jmp UART_RXC0	; UART0 RX Complete Handler
\$01c		jmp UART_RXC1	; UART1 RX Complete Handler
\$01e		jmp UART_DRE0	; UDR0 Empty Handler
\$020		jmp UART_DRE1	; UDR1 Empty Handler
\$022		jmp UART_TXC0	; UART0 TX Complete Handler
\$024		jmp UART_TXC1	; UART1 TX Complete Handler
\$026		jmp EE_RDY	; EEPROM Ready Handler
\$028		jmp ANA_COMP	; Analog Comparator Handler
			;
\$02a	MAIN:	ldi r16,high(RAMEND)	; Main program start
\$02b		out SPH,r16	
\$02c		ldi r16,low(RAMEND)	
\$02d		out SPL,r16	
\$02e		<instr> xxx	
			;
.org \$1e00			
\$1e00		jmp RESET	; Reset handler
...	...	...	...

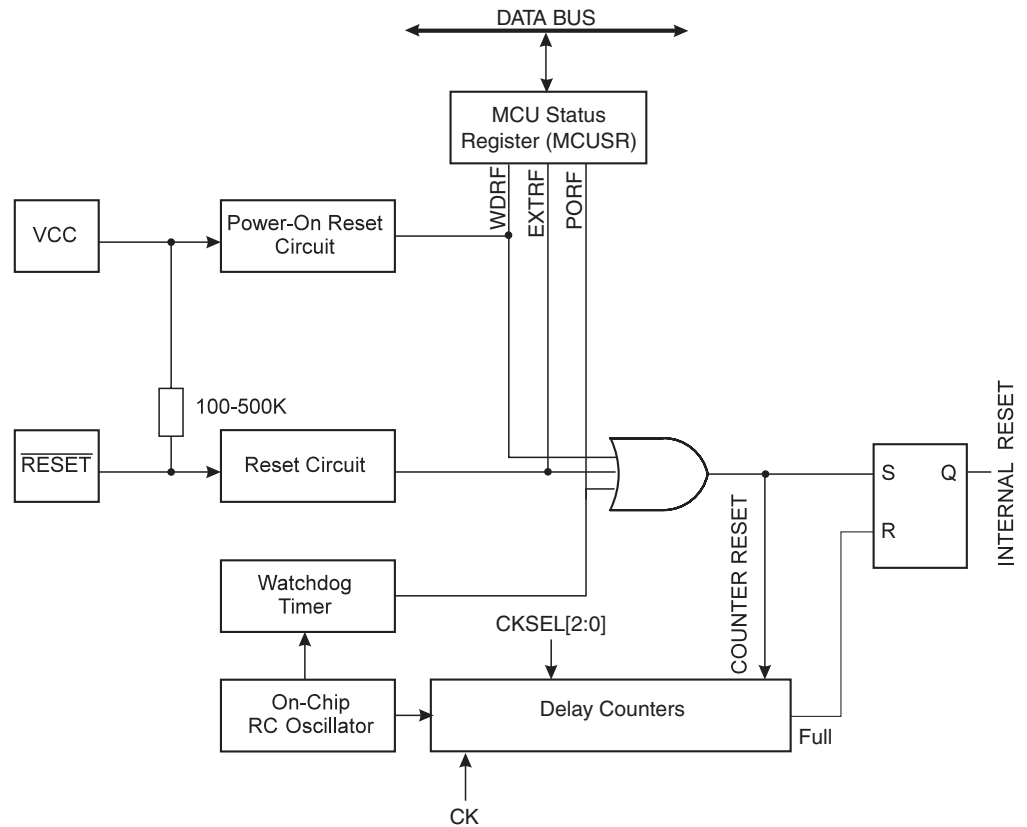
## Reset Sources

The ATmega161 has three sources of Reset:

- Power-on Reset. The MCU is reset when the supply voltage is below the Power-on Reset threshold ( $V_{POT}$ ).
- External Reset. The MCU is reset when a low level is present on the  $\overline{RESET}$  pin for more than 500 ns.
- Watchdog Reset. The MCU is reset when the Watchdog Timer period expires and the Watchdog is enabled.

During Reset, all I/O Registers are then set to their initial values and the program starts execution from address \$000. The instruction placed in address \$000 must be a JMP (relative jump) instruction to the reset handling routine. If the program never enables an interrupt source, the Interrupt Vectors are not used and regular program code can be placed at these locations. The circuit diagram in Figure 24 shows the Reset Logic. Table 3 and Table 4 define the timing and electrical parameters of the reset circuitry.

**Figure 24.** Reset Logic



**Table 3.** Reset Characteristics ( $V_{CC} = 5.0V$ )<sup>(1)</sup>

Symbol	Parameter	Min	Typ	Max	Units
$V_{POT}$	Power-on Reset Threshold Voltage (rising)	1.0	1.4	1.8	V
	Power-on Reset Threshold Voltage (falling) <sup>(1)</sup>	0.4	0.6	0.8	V
$V_{RST}$	$\overline{RESET}$ Pin Threshold Voltage			$0.85 V_{CC}$	V

Note: 1. The Power-on Reset will not work unless the supply voltage has been below  $V_{POT}$  (falling).

**Table 4.** Reset Delay Selections<sup>(3)</sup>

CKSEL [2:0]	Start-up Time, $V_{CC} = 2.7V$ , SUT Unprogrammed	Start-up Time, $V_{CC} = 4.0V$ , SUT Programmed	Recommended Usage <sup>(1)</sup>
000	4.2 ms + 6 CK	5.8 ms + 6 CK	External Clock, Fast Rising Power
001	30 $\mu$ s + 6 CK	10 $\mu$ s + 6 CK	External Clock <sup>(2)</sup>
010	67 ms + 16K CK	92 ms + 16K CK	Crystal Oscillator, Slowly Rising Power
011	4.2 ms + 16K CK	5.8 ms + 16K CK	Crystal Oscillator, Fast Rising Power
100	30 $\mu$ s + 16K CK	10 $\mu$ s + 16K CK	Crystal Oscillator <sup>(2)</sup>
101	67 ms + 1K CK	92 ms + 1K CK	Ceramic Resonator/External Clock, Slowly Rising Power
110	4.2 ms + 1K CK	5.8 ms + 1K CK	Ceramic Resonator, Fast Rising Power
111	30 $\mu$ s + 1K CK	10 $\mu$ s + 1K CK	Ceramic Resonator <sup>(2)</sup>

Notes: 1. The CKSEL fuses control only the start-up time. The Oscillator is the same for all selections. On Power-up, the real-time part of the start-up time is increased with typ. 0.6 ms.  
 2. External Power-on Reset.  
 3. Table 4 shows the Start-up Times from Reset. From sleep, only the clock counting part of the start-up time is used. The Watchdog Oscillator is used for timing the real-time part of the start-up time. The number WDT Oscillator cycles used for each time-out is shown in Table 5.

**Table 5.** Number of Watchdog Oscillator Cycles

SUT	Time-out	Number of Cycles
Unprogrammed	4.2 ms (at $V_{CC} = 2.7V$ )	1K
Unprogrammed	67 ms (at $V_{CC} = 2.7V$ )	16K
Programmed	5.8 ms (at $V_{CC} = 4.0V$ )	4K
Programmed	92 ms (at $V_{CC} = 4.0V$ )	64K

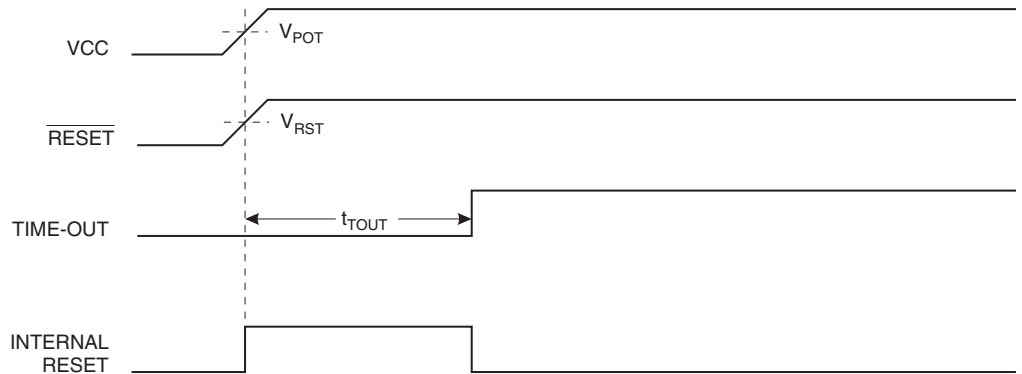
The frequency of the Watchdog Oscillator is voltage-dependent as shown in the Electrical Characteristics section. The device is shipped with CKSEL = 010.

## Power-on Reset

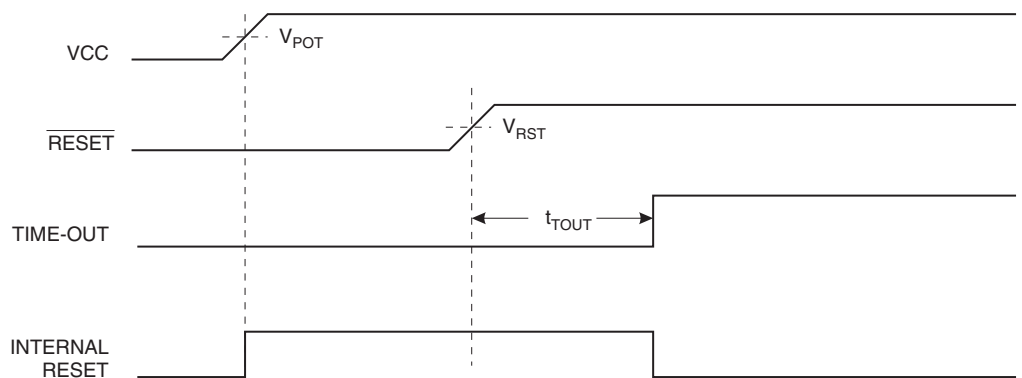
A Power-on Reset (POR) pulse is generated by an On-chip detection circuit. The detection level is nominally 1.4V (rising  $V_{CC}$ ). The POR is activated whenever  $V_{CC}$  is below the detection level. The POR circuit can be used to trigger the Start-up Reset, as well as detect a failure in supply voltage.

A Power-on Reset (POR) circuit ensures that the device is reset from Power-on. Reaching the Power-on Reset threshold voltage invokes a delay counter, which determines the delay, for which the device is kept in RESET after  $V_{CC}$  rise. The time-out period of the delay counter can be defined by the user through the CKSEL fuses. The eight different selections for the delay period are presented in Table 4. The RESET signal is activated again, without any delay, when the  $V_{CC}$  decreases below detection level.

**Figure 25.** MCU Start-up,  $\overline{\text{RESET}}$  Tied to  $V_{CC}$



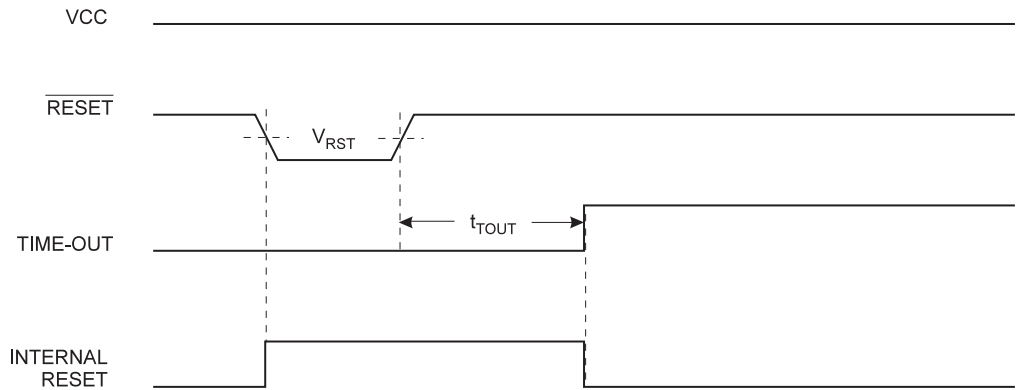
**Figure 26.** MCU Start-up,  $\overline{\text{RESET}}$  Controlled Externally



## External Reset

An External Reset is generated by a low level on the  $\overline{\text{RESET}}$  pin. Reset pulses longer than 500 ns will generate a Reset, even if the clock is not running. Shorter pulses are not guaranteed to generate a Reset. When the applied signal reaches the Reset Threshold Voltage ( $V_{\text{RST}}$ ) on its positive edge, the delay timer starts the MCU after the Time-out period ( $t_{\text{TOUT}}$ ) has expired.

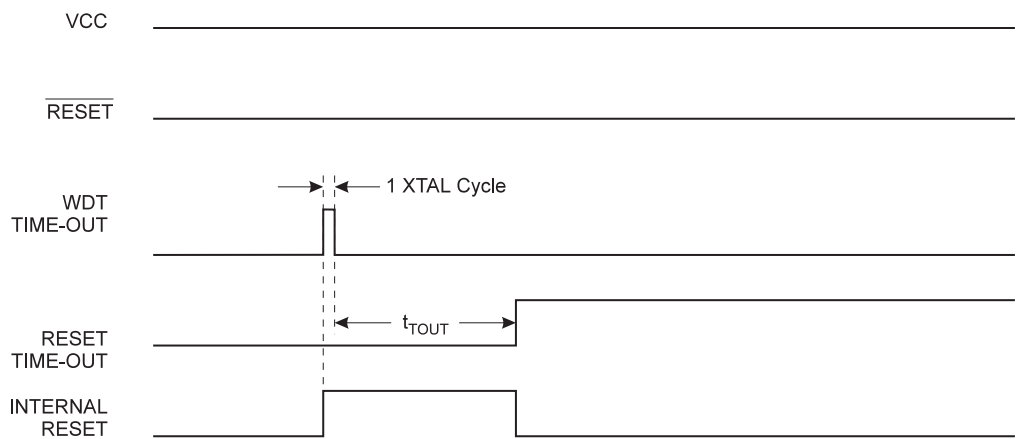
**Figure 27.** External Reset during Operation



## Watchdog Reset

When the Watchdog times out, it will generate a short reset pulse of 1 XTAL cycle duration. On the falling edge of this pulse, the delay timer starts counting the Time-out period ( $t_{\text{TOUT}}$ ). Refer to page 58 for details on operation of the Watchdog.

**Figure 28.** Watchdog Reset during Operation



## MCU Status Register – MCUSR

The MCU Status Register provides information on which reset source caused an MCU Reset.

Bit	7	6	5	4	3	2	1	0	
\$34 (\$54)	–	–	–	–	WDRF	–	EXTRF	PORF	MCUSR
Read/Write	R	R	R	R	R/W	R	R/W	R/W	
Initial Value	0	0	0	0			See Bit Description		

- **Bits 7..4 – Res: Reserved Bits**

These bits are reserved bits in the ATmega161 and always read as zero.

- **Bit 3 – WDRF: Watchdog Reset Flag**

This bit is set if a Watchdog Reset occurs. The bit is cleared by a Power-on Reset or by writing a logical “0” to the Flag.

- **Bit 2 – Res: Reserved Bit**

This bit are reserved bit in the ATmega161 and always read as zero.

- **Bit 1 – EXTRF: External Reset Flag**

This bit is set if an External Reset occurs. The bit is cleared by a Power-on Reset or by writing a logical “0” to the Flag.

- **Bit 0 – PORF: Power-on Reset Flag**

This bit is set if a Power-on Reset occurs. The bit is cleared only by writing a logical “0” to the Flag.

To make use of the Reset Flags to identify a reset condition, the user should read and then clear the MCUSR as early as possible in the program. If the register is cleared before another reset occurs, the source of the reset can be found by examining the Reset Flags.

## Interrupt Handling

The ATmega161 has two 8-bit Interrupt Mask Control Registers; GIMSK (General Interrupt Mask Register) and TIMSK (Timer/Counter Interrupt Mask Register).

When an interrupt occurs, the Global Interrupt Enable I-bit is cleared (zero) and all interrupts are disabled. The user software can set (one) the I-bit to enable nested interrupts. The I-bit is set (one) when a Return from Interrupt instruction (RETI) is executed.

When the Program Counter is vectored to the actual Interrupt Vector in order to execute the interrupt handling routine, hardware clears the corresponding flag that generated the interrupt. Some of the Interrupt Flags can also be cleared by writing a logical “1” to the Flag bit position(s) to be cleared.

If an interrupt condition occurs when the corresponding interrupt enable bit is cleared (zero), the Interrupt Flag will be set and remembered until the interrupt is enabled or the Flag is cleared by software.

If one or more interrupt conditions occur when the global interrupt enable bit is cleared (zero), the corresponding Interrupt Flag(s) will be set and remembered until the global interrupt enable bit is set (one), and will be executed by order of priority.

Note that external level interrupt does not have a flag and will only be remembered for as long as the interrupt condition is present.

Note that the Status Register is not automatically stored when entering an interrupt routine or restored when returning from an interrupt routine. This must be handled by software.

### Interrupt Response Time

The interrupt execution response for all the enabled AVR interrupts is four clock cycles minimum. After four clock cycles, the Program Vector address for the actual interrupt handling routine is executed. During this four-clock-cycle period, the Program Counter (13 bits) is pushed onto the Stack. The Vector is normally a jump to the interrupt routine, and this jump takes three clock cycles. If an interrupt occurs during execution of a multi-cycle instruction, this instruction is completed before the interrupt is served. If an interrupt occurs when the MCU is in Sleep mode, the interrupt execution response time is increased by four clock cycles.

A return from an interrupt handling routine takes four clock cycles. During these four clock cycles, the Program Counter (2 bytes) is popped back from the Stack, the Stack Pointer is incremented by 2, and the I-Flag in SREG is set. When AVR exits from an interrupt, it will always return to the main program and execute one more instruction before any pending interrupt is served.

### General Interrupt Mask Register – GIMSK

Bit	7	6	5	4	3	2	1	0	
\$3B (\$5B)	INT1	INT0	INT2	–	–	–	–	–	GIMSK
Read/Write	R/W	R/W	R	R	R	R	R	R	
Initial Value	0	0	0	0	0	0	0	0	

- **Bit 7 – INT1: External Interrupt Request 1 Enable**

When the INT1 bit is set (one) and the I-bit in the Status Register (SREG) is set (one), the external pin interrupt is enabled. The Interrupt Sense Control1 bits 1/0 (ISC11 and ISC10) in the MCU general Control Register (MCUCR) define whether the external interrupt is activated on rising and/or falling edge of the INT1 pin or is level-sensed. Activity on the pin will cause an interrupt request even if INT1 is configured as an output. The corresponding interrupt of External Interrupt Request 1 is executed from Program memory address \$004. See also “External Interrupts”.

- **Bit 6 – INT0: External Interrupt Request 0 Enable**

When the INT0 bit is set (one) and the I-bit in the Status Register (SREG) is set (one), the external pin interrupt is enabled. The Interrupt Sense Control0 bits 1/0 (ISC01 and ISC00) in the MCU general Control Register (MCUCR) define whether the external interrupt is activated on rising and/or falling edge of the INT0 pin or is level-sensed. Activity on the pin will cause an interrupt request even if INT0 is configured as an output. The corresponding interrupt of External Interrupt Request 0 is executed from Program memory address \$002. See also “External Interrupts.”

- **Bit 5 – INT2: External Interrupt Request 2 Enable**

When the INT2 bit is set (one) and the I-bit in the Status Register (SREG) is set (one), the external pin interrupt is activated. The Interrupt Sense Control2 bit (ISC02 in the Extended MCU Control Register [EMUCR]) defines whether the external interrupt is activated on rising or falling edge of the INT2 pin. Activity on the pin will cause an interrupt request even if INT2 is configured as an output. The corresponding interrupt of External Interrupt Request 2 is executed from Program memory address \$006. See also “External Interrupts.”

- **Bits 4..0 – Res: Reserved Bits**

These bits are reserved bits in the ATmega161 and always read as zero.

## General Interrupt Flag Register – GIFR

Bit	7	6	5	4	3	2	1	0	
\$3A (\$5A)	INTF1	INTF0	INTF2	–	–	–	–	–	GIFR
Read/Write	R/W	R/W	R/W	R	R	R	R	R	
Initial Value	0	0	0	0	0	0	0	0	

- **Bit 7 – INTF1: External Interrupt Flag1**

When an event on the INT1 pin triggers an interrupt request, INTF1 becomes set (one). If the I-bit in SREG and the INT1 bit in GIMSK are set (one), the MCU will jump to the Interrupt Vector at address \$004. The Flag is cleared when the interrupt routine is executed. Alternatively, the Flag can be cleared by writing a logical “1” to it.

- **Bit 6 – INTF0: External Interrupt Flag0**

When an event on the INT0 pin triggers an interrupt request, INTF0 becomes set (one). If the I-bit in SREG and the INT0 bit in GIMSK are set (one), the MCU will jump to the Interrupt Vector at address \$002. The Flag is cleared when the interrupt routine is executed. Alternatively, the Flag can be cleared by writing a logical “1” to it.

- **Bit 5 – INTF2: External Interrupt Flag2**

When an event on the INT2 pin triggers an interrupt request, INTF2 becomes set (one). If the I-bit in SREG and the INT2 bit in GIMSK are set (one), the MCU will jump to the Interrupt Vector at address \$006. The Flag is cleared when the interrupt routine is executed. Alternatively, the Flag can be cleared by writing a logical “1” to it.

- **Bits 4..0 – Res: Reserved Bits**

These bits are reserved bits in the ATmega161 and always read as zero.

## Timer/Counter Interrupt Mask Register – TIMSK

Bit	7	6	5	4	3	2	1	0	
\$39 (\$59)	TOIE1	OCIE1A	OCIE1B	TOIE2	TICIE1	OCIE2	TOIE0	OCIE0	TIMSK
Read/Write	R/W	R/W	R/W	R/W	R/W	R/W	R/W	R/W	
Initial Value	0	0	0	0	0	0	0	0	

- **Bit 7 – TOIE1: Timer/Counter1 Overflow Interrupt Enable**

When the TOIE1 bit is set (one) and the I-bit in the Status Register is set (one), the Timer/Counter1 Overflow interrupt is enabled. The corresponding interrupt (at Vector \$012) is executed if an overflow in Timer/Counter1 occurs, i.e., when the TOV1 bit is set in the Timer/Counter Interrupt Flag Register (TIFR).

- **Bit 6 – OCE1A: Timer/Counter1 Output CompareA Match Interrupt Enable**

When the OCIE1A bit is set (one) and the I-bit in the Status Register is set (one), the Timer/Counter1 CompareA Match interrupt is enabled. The corresponding interrupt (at Vector \$00e) is executed if a Compare A Match in Timer/Counter1 occurs, i.e., when the OCF1A bit is set in the Timer/Counter Interrupt Flag Register (TIFR).

- **Bit 5 – OCIE1B: Timer/Counter1 Output CompareB Match Interrupt Enable**

When the OCIE1B bit is set (one) and the I-bit in the Status Register is set (one), the Timer/Counter1 CompareB Match interrupt is enabled. The corresponding interrupt (at Vector \$010) is executed if a Compare B Match in Timer/Counter1 occurs, i.e., when the OCF1B bit is set in the Timer/Counter Interrupt Flag Register (TIFR).

- **Bit 4 – TOIE2: Timer/Counter2 Overflow Interrupt Enable**

When the TOIE2 bit is set (one) and the I-bit in the Status Register is set (one), the Timer/Counter2 Overflow interrupt is enabled. The corresponding interrupt (at Vector \$00a) is executed if an overflow in Timer/Counter2 occurs, i.e., when the TOV2 bit is set in the Timer/Counter Interrupt Flag Register (TIFR).

- **Bit 3 – TICIE1: Timer/Counter1 Input Capture Interrupt Enable**

When the TICIE1 bit is set (one) and the I-bit in the Status Register is set (one), the Timer/Counter1 Input Capture Event Interrupt is enabled. The corresponding interrupt (at Vector \$00C) is executed if a capture-triggering event occurs on pin 31, ICP, i.e., when the ICF1 bit is set in the Timer/Counter Interrupt Flag Register (TIFR).

- **Bit 2 – OCIE2: Timer/Counter2 Output Compare Match Interrupt Enable**

When the OCIE2 bit is set (one) and the I-bit in the Status Register is set (one), the Timer/Counter2 Compare Match interrupt is enabled. The corresponding interrupt (at Vector \$008) is executed if a Compare2 match in Timer/Counter2 occurs, i.e., when the OCF2 bit is set in the Timer/Counter Interrupt Flag Register (TIFR).

- **Bit 1 – TOIE0: Timer/Counter0 Overflow Interrupt Enable**

When the TOIE0 bit is set (one) and the I-bit in the Status Register is set (one), the Timer/Counter0 Overflow interrupt is enabled. The corresponding interrupt (at Vector \$016) is executed if an overflow in Timer/Counter0 occurs, i.e., when the TOV0 bit is set in the Timer/Counter Interrupt Flag Register (TIFR).

- **Bit 0 – OCIE0: Timer/Counter0 Output Compare Match Interrupt Enable**

When the OCIE0 bit is set (one) and the I-bit in the Status Register is set (one), the Timer/Counter0 Compare Match interrupt is enabled. The corresponding interrupt (at Vector \$014) is executed if a Compare 0 Match in Timer/Counter0 occurs, i.e., when the OCF0 bit is set in the Timer/Counter Interrupt Flag Register (TIFR).

## Timer/Counter Interrupt Flag Register – TIFR

Bit	7	6	5	4	3	2	1	0	
\$38 (\$58)	TOV1	OCF1A	OCIFB	TOV2	ICF1	OCF2	TOV0	OCF0	TIFR
Read/Write	R/W	R/W	R/W	R/W	R/W	R/W	R/W	R/W	
Initial Value	0	0	0	0	0	0	0	0	

- **Bit 7 – TOV1: Timer/Counter1 Overflow Flag**

The TOV1 is set (one) when an overflow occurs in Timer/Counter1. TOV1 is cleared by hardware when executing the corresponding Interrupt Handling Vector. Alternatively, TOV1 is cleared by writing a logical “1” to the Flag. When the I-bit in SREG, and TOIE1 (Timer/Counter1 Overflow Interrupt Enable), and TOV1 are set (one), the Timer/Counter1 Overflow Interrupt is executed. In PWM mode, this bit is set when Timer/Counter1 changes counting direction at \$0000.

- **Bit 6 – OCF1A: Output Compare Flag 1A**

The OCF1A bit is set (one) when a compare match occurs between the Timer/Counter1 and the data in OCR1A (Output Compare Register 1A). OCF1A is cleared by hardware when executing the corresponding Interrupt Handling Vector. Alternatively, OCF1A is cleared by writing a logical “1” to the Flag. When the I-bit in SREG and OCIE1A (Timer/Counter1 Compare Match Interrupt A Enable) and OCF1A are set (one), the Timer/Counter1 Compare A Match Interrupt is executed.

- **Bit 5 – OCF1B: Output Compare Flag 1B**

The OCF1B bit is set (one) when a compare match occurs between the Timer/Counter1 and the data in OCR1B (Output Compare Register 1B). OCF1B is cleared by hardware when executing the corresponding Interrupt Handling Vector. Alternatively, OCF1B is cleared by writing a logical “1” to the Flag. When the I-bit in SREG and OCIE1B (Timer/Counter1 Compare Match Interrupt B Enable) and OCF1B are set (one), the Timer/Counter1 Compare B Match Interrupt is executed.

- **Bit 4 – TOV2: Timer/Counter2 Overflow Flag**

The bit TOV2 is set (one) when an overflow occurs in Timer/Counter2. TOV2 is cleared by hardware when executing the corresponding Interrupt Handling Vector. Alternatively, TOV2 is cleared by writing a logical “1” to the Flag. When the SREG I-bit and TOIE2 (Timer/Counter2 Overflow Interrupt Enable) and TOV2 are set (one), the Timer/Counter2 Overflow interrupt is executed.

- **Bit 3 – ICF1: Input Capture Flag 1**

The ICF1 bit is set (one) to flag an Input Capture Event, indicating that the Timer/Counter1 value has been transferred to the Input Capture Register (ICR1). ICF1 is cleared by hardware when executing the corresponding Interrupt Handling Vector. Alternatively, ICF1 is cleared by writing a logical “1” to the Flag. When the SREG I-bit and TICIE1 (Timer/Counter1 Input Capture Interrupt Enable) and ICF1 are set (one), the Timer/Counter1 Capture Interrupt is executed.

- **Bit 2 – OCF2: Output Compare Flag 2**

The OCF2 bit is set (one) when a Compare Match occurs between the Timer/Counter2 and the data in OCR2 (Output Compare Register 2). OCF2 is cleared by hardware when executing the corresponding Interrupt Handling Vector. Alternatively, OCF2 is cleared by writing a logical “1” to the Flag. When the I-bit in SREG and OCIE2 (Timer/Counter2

Compare match InterruptA Enable) and the OCF2 are set (one), the Timer/Counter2 Compare match Interrupt is executed.

- **Bit 1 – TOV0: Timer/Counter0 Overflow Flag**

The bit TOV0 is set (one) when an overflow occurs in Timer/Counter0. TOV0 is cleared by hardware when executing the corresponding Interrupt Handling Vector. Alternatively, TOV0 is cleared by writing a logical “1” to the Flag. When the SREG I-bit and TOIE0 (Timer/Counter0 Overflow Interrupt Enable) and TOV0 are set (one), the Timer/Counter0 Overflow interrupt is executed.

- **Bit 2 – OCF0: Output Compare Flag 0**

The OCF0 bit is set (one) when compare match occurs between the Timer/Counter0 and the data in OCR0 (Output Compare Register 0). OCF0 is cleared by hardware when executing the corresponding Interrupt Handling Vector. Alternatively, OCF0 is cleared by writing a logical “1” to the Flag. When the I-bit in SREG and OCIE0 (Timer/Counter0 Compare match InterruptA Enable) and the OCF0 are set (one), the Timer/Counter0 Compare match Interrupt is executed.

## External Interrupts

The external interrupts are triggered by the INT0, INT1, and INT2 pins. Observe that, if enabled, the interrupts will trigger even if the INT0/INT1/INT2 pins are configured as outputs. This feature provides a way of generating a software interrupt. The external interrupts can be triggered by a falling or rising edge or a low level (INT2 is only an edge triggered interrupt). This is set up as indicated in the specification for the MCU Control Register – MCUCR (INT0/INT1) and EMCUCR (INT2). When the external interrupt is enabled and is configured as level triggered (only INT0/INT1), the interrupt will trigger as long as the pin is held low.

## MCU Control Register – MCUCR

The MCU Control Register contains control bits for general MCU functions.

Bit	7	6	5	4	3	2	1	0	
\$35 (\$55)	<b>SRE</b>	<b>SRW10</b>	<b>SE</b>	<b>SM1</b>	<b>ISC11</b>	<b>ISC10</b>	<b>ISC01</b>	<b>ISC00</b>	MCUCR
Read/Write	R/W	R/W	R/W	R/W	R/W	R/W	R/W	R/W	
Initial Value	0	0	0	0	0	0	0	0	

- **Bit 7 – SRE: External SRAM Enable**

When the SRE bit is set (one), the external Data memory interface is enabled and the pin functions AD0 - 7 (Port A), A8 - 5 (Port C), ALE (Port E),  $\overline{WR}$ , and  $\overline{RD}$  (Port D) are activated as the alternate pin functions. The SRE bit overrides any pin direction settings in the respective Data Direction Registers. See Figure 50 through Figure 53 for a description of the external memory pin functions. When the SRE bit is cleared (zero), the external Data memory interface is disabled and the normal pin and data direction settings are used.

- **Bit 6 – SRW10: External SRAM Wait State**

The SRW10 bit is used to set up extra wait states in the external memory interface. See “Double-speed Transmission” on page 78 for a detailed description.

- **Bit 5 – SE: Sleep Enable**

The SE bit must be set (one) to make the MCU enter the Sleep mode when the SLEEP instruction is executed. To avoid the MCU entering the Sleep mode unless it is the pro-

grammer's purpose, it is recommended to set the Sleep Enable (SE) bit just before the execution of the SLEEP instruction.

- **Bit 4 – SM1: Sleep Mode Select Bit 1**

The SM1 bit, together with the SM0 control bit in EMCUCR, selects between the three available Sleep modes as shown in Table 6.

**Table 6.** Sleep Mode Select

SM1	SM0	Sleep Mode
0	0	Idle
0	1	Reserved
1	0	Power-down
1	1	Power-save

- **Bits 3, 2 – ISC11, ISC10: Interrupt Sense Control 1 Bit 1 and Bit 0**

The External Interrupt 1 is activated by the external pin INT1 if the SREG I-Flag and the corresponding interrupt mask in the GIMSK are set. The level and edges on the external INT1 pin that activate the interrupt are defined in Table 7. The value on the INT1 pin is sampled before detecting edges. If edge or toggle interrupt is selected, pulses that last longer than one clock period will generate an interrupt. Shorter pulses are not guaranteed to generate an interrupt. If low-level interrupt is selected, the low level must be held until the completion of the currently executing instruction to generate an interrupt.

**Table 7.** Interrupt 1 Sense Control

ISC11	ISC10	Description
0	0	The low level of INT1 generates an interrupt request.
0	1	Any logical change on INT1 generates an interrupt request.
1	0	The falling edge of INT1 generates an interrupt request.
1	1	The rising edge of INT1 generates an interrupt request.

- **Bits 1, 0 – ISC01, ISC00: Interrupt Sense Control 0 Bit 1 and Bit 0**

The External Interrupt 0 is activated by the external pin INT0 if the SREG I-Flag and the corresponding interrupt mask is set. The level and edges on the external INT0 pin that activate the interrupt are defined in Table 8. The value on the INT0 pin is sampled before detecting edges. If edge or toggle interrupt is selected, pulses that last longer than one clock period will generate an interrupt. Shorter pulses are not guaranteed to generate an interrupt. If low-level interrupt is selected, the low level must be held until the completion of the currently executing instruction to generate an interrupt.

**Table 8.** Interrupt 0 Sense Control

ISC01	ISC00	Description
0	0	The low level of INT0 generates an interrupt request.
0	1	Any logical change on INT0 generates an interrupt request.
1	0	The falling edge of INT0 generates an interrupt request.
1	1	The rising edge of INT0 generates an interrupt request.

## Extended MCU Control Register – EMCUCR

The Extended MCU Control Register contains control bits for External Interrupt 2, Sleep mode bit and control bits for the external memory interface.

Bit	7	6	5	4	3	2	1	0	
\$36 (\$56)	<b>SM0</b>	<b>SRL2</b>	<b>SRL1</b>	<b>SRL0</b>	<b>SRW01</b>	<b>SRW00</b>	<b>SRW11</b>	<b>ISC2</b>	EMCUCR
Read/Write	R/W	R/W	R/W	R/W	R/W	R/W	R/W	R/W	
Initial Value	0	0	0	0	0	0	0	0	

- **Bit 7 – SM0: Sleep Mode Bit 0**

When this bit is set (one) and Sleep mode bit 1 (SM1) in MCUCR is set, Power-save mode is selected as Sleep mode. Refer to page 36 for a detailed description of the Sleep modes.

- **Bits 6..4 – SRL2, SRL1, SRL0: External SRAM Limit**

It is possible to configure different wait states for different external memory addresses in ATmega161. The SRL2 - SRL0 bits are used to define at which address the different wait states will be configured. See “Interface to External Memory” on page 84 for a detailed description.

- **Bits 3..1 – SRW01, SRW00, SRW11: External SRAM Wait State Select Bits**

The SRW01, SRW00 and SRW11 bits are used to set up extra wait states in the external memory interface. See “Interface to External Memory” on page 84 for a detailed description.

- **Bit 0 – ISC2: Interrupt Sense Control 2**

The external interrupt 2 is activated by the external pin INT2 if the SREG I-Flag and the corresponding interrupt mask in the GIMSK are set. If ISC2 is cleared (zero), a falling edge on INT2 activates the interrupt. If ISC2 is set (one), a rising edge on INT2 activates the interrupt. Edges on INT2 are registered asynchronously. Pulses on INT2 wider than 50 ns will generate an interrupt. Shorter pulses are not guaranteed to generate an interrupt.

When changing the ISC2 bit, an interrupt can occur. Therefore, it is recommended to first disable INT2 by clearing its Interrupt Enable bit in the GIMSK Register. Then, ISC2 bit can be changed. Finally, the INT2 Interrupt Flag should be cleared by writing a logical “1” to its Interrupt Flag bit in the GIFR Register before the interrupt is re-enabled.

## Sleep Modes

To enter any of the three Sleep modes, the SE bit in MCUCR must be set (one) and a SLEEP instruction must be executed. The SM1 bit in the MCUCR Register and SM0 bit in the EMCUCR Register select which Sleep mode (Idle, Power-down or Power-save) will be activated by the SLEEP instruction (see Table 6). If an enabled interrupt occurs while the MCU is in a Sleep mode, the MCU awakes. The CPU is then halted for four cycles, it executes the interrupt routine, and resumes execution from the instruction following SLEEP. The contents of the Register File, SRAM and I/O memory are unaltered. If a reset occurs during Sleep mode, the MCU wakes up and executes from the Reset Vector.

### Idle Mode

When the SM1/SM0 bits are set to 00, the SLEEP instruction makes the MCU enter the Idle mode, stopping the CPU but allowing SPI, UARTs, Analog Comparator, Timer/Counters, Watchdog, and the Interrupt System to continue operating. This enables the MCU to wake up from external triggered interrupts as well as internal ones like the Timer Overflow and UART Receive Complete interrupts. If wake-up from the

Analog Comparator interrupt is not required, the Analog Comparator can be powered down by setting the ACD bit in the Analog Comparator Control and Status Register (ACSR). This will reduce power consumption in Idle mode.

## Power-down Mode

When the SM1/SM0 bits are set to 10, the SLEEP instruction makes the MCU enter the Power-down mode. In this mode, the external Oscillator is stopped while the external interrupts and the Watchdog (if enabled) continue operating. Only an External Reset, a Watchdog Reset (if enabled), an external level interrupt on INT0 or INT1, or an external edge interrupt on INT2 can wake up the MCU.

If INT2 is used for wake-up from Power-down mode, the edge is remembered until the MCU wakes up.

If a level-triggered interrupt is used for wake-up from Power-down mode, the changed level must be held for some time to wake up the MCU. This makes the MCU less sensitive to noise. The changed level is sampled twice by the Watchdog Oscillator clock, and if the input has the required level during this time, the MCU will wake up. The period of the Watchdog Oscillator is 1  $\mu$ s (nominal) at 5.0V and 25°C. The frequency of the Watchdog Oscillator is voltage-dependent as shown in the Electrical Characteristics section.

When waking up from Power-down mode, a delay from the wake-up condition occurs until the wake-up becomes effective. This allows the clock to restart and become stable after having been stopped. The wake-up period is defined by the same CKSEL fuses that define the Reset Time-out period. The wake-up period is equal to the clock counting part of the reset period, as shown in Table 4. If the wake-up condition disappears before the MCU wakes up and starts to execute, e.g., a low level on INT0 is not held long enough, the interrupt causing the wake-up will not be executed.

## Power-save Mode

When the SM1/SM0 bits are 11, the SLEEP instruction makes the MCU enter the Power-save mode. This mode is identical to Power-down, with one exception.

If Timer/Counter2 is clocked asynchronously, i.e., the AS2 bit in ASSR is set, Timer/Counter2 will run during sleep. In addition to the Power-down wake-up sources, the device can also wake up from either Timer Overflow or Output Compare event from Timer/Counter2 if the corresponding Timer/Counter2 interrupt enable bits are set in TIMSK and the global interrupt enable bit in SREG is set.

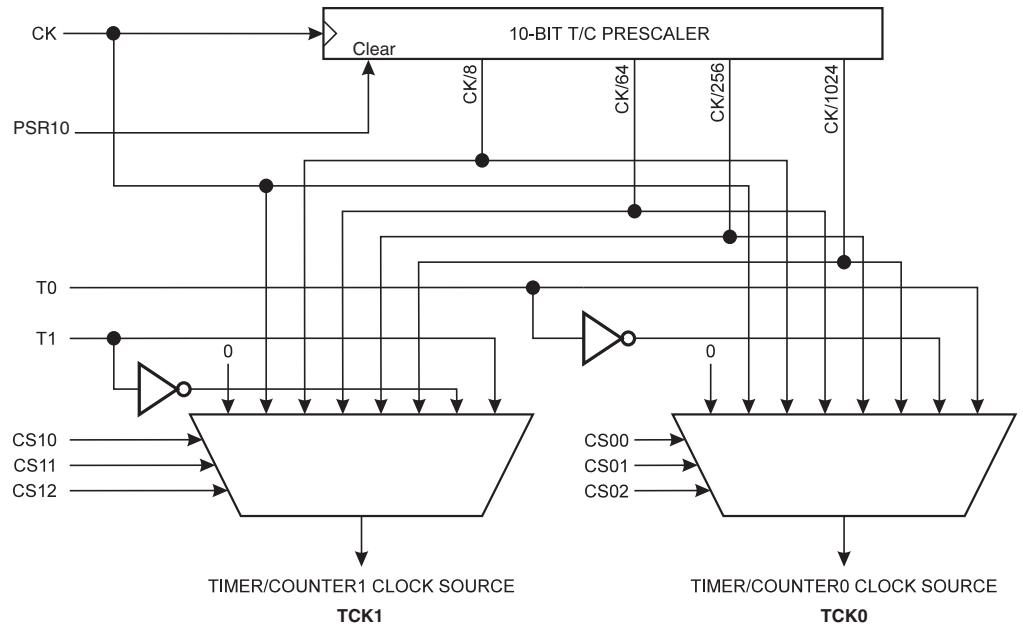
If the asynchronous timer is *not* clocked asynchronously, Power-down mode is recommended instead of Power-save mode because the contents of the register in the asynchronous timer should be considered undefined after wake-up in Power-save mode even if AS2 is 0.

## Timer/Counters

The ATmega161 provides three general purpose Timer/Counters – two 8-bit T/Cs and one 16-bit T/C. Timer/Counter2 can optionally be asynchronously clocked from an external Oscillator. This Oscillator is optimized for use with a 32.768 kHz watch crystal, enabling use of Timer/Counter2 as a Real-time Clock (RTC). Timer/Counters 0 and 1 have individual prescaling selection from the same 10-bit prescaling timer. Timer/Counter2 has its own prescaler. Both these prescalers can be Reset by setting the corresponding control bits in the Special Functions IO Register (SFIOR). Refer to page 39 for a detailed description. These Timer/Counters can either be used as a timer with an internal clock time base or as a counter with an external pin connection, which triggers the counting.

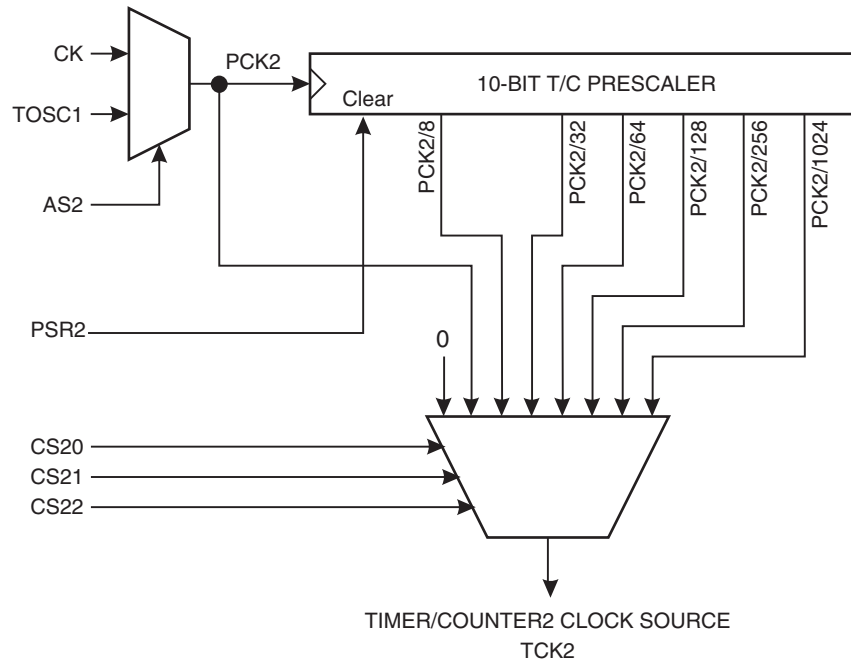
### Timer/Counter Prescalers

**Figure 29.** Prescaler for Timer/Counter0 and 1



For Timer/Counters 0 and 1, the four prescaled selections are: CK/8, CK/64, CK/256, and CK/1024, where CK is the Oscillator clock. For the two Timer/Counters 0 and 1, CK, external source and stop can also be selected as clock sources. Setting the PSR10 bit in SFIOR Resets the prescaler. This allows the user to operate with a predictable prescaler. Note that Timer/Counter1 and Timer/Counter0 share the same prescaler and a Prescaler Reset will affect both Timer/Counters.

**Figure 30. Timer/Counter2 Prescaler**



The clock source for Timer/Counter2 prescaler is named PCK2. PCK2 is by default connected to the main system clock (CK). By setting the AS2 bit in ASSR, Timer/Counter2 is asynchronously clocked from the PD4(TOSC1) pin. This enables use of Timer/Counter2 as a Real-time Clock (RTC). When AS2 is set, pins PD4(TOSC1) and PD5(TOSC2) are disconnected from Port D. A crystal can then be connected between the PD4(TOSC1) and PD5(TOSC2) pins to serve as an independent clock source for Timer/Counter2. The Oscillator is optimized for use with a 32.768 kHz crystal. Alternatively, an external clock signal can be applied to PD4(TOSC1). The frequency of this clock must be lower than one fourth of the CPU clock and not higher than 256 kHz. Setting the PSR2 bit in SFIOR Resets the prescaler. This allows the user to operate with a predictable prescaler.

### Special Function IO Register – SFIOR

Bit	7	6	5	4	3	2	1	0	
\$30 (\$50)	-	-	-	-	-	-	PSR2	PSR10	SFIOR
Read/Write	R	R	R	R	R	R	R/W	R/W	
Initial Value	0	0	0	0	0	0	0	0	

- **Bits 7..2 – Res: Reserved Bits**

These bits are reserved bits in the ATmega161 and always read as zero.

- **Bit 1 – PSR2: Prescaler Reset Timer/Counter2**

When this bit is set (one), the Timer/Counter2 prescaler will be reset. The bit will be cleared by hardware after the operation is performed. Writing a zero to this bit will have no effect. This bit will always be read as zero if Timer/Counter2 is clocked by the internal CPU clock. If this bit is written when Timer/Counter2 is operating in asynchronous mode, however, the bit will remain as one until the prescaler has been reset. See “Asynchronous Operation of Timer/Counter2” on page 48 for a detailed description of asynchronous operation.

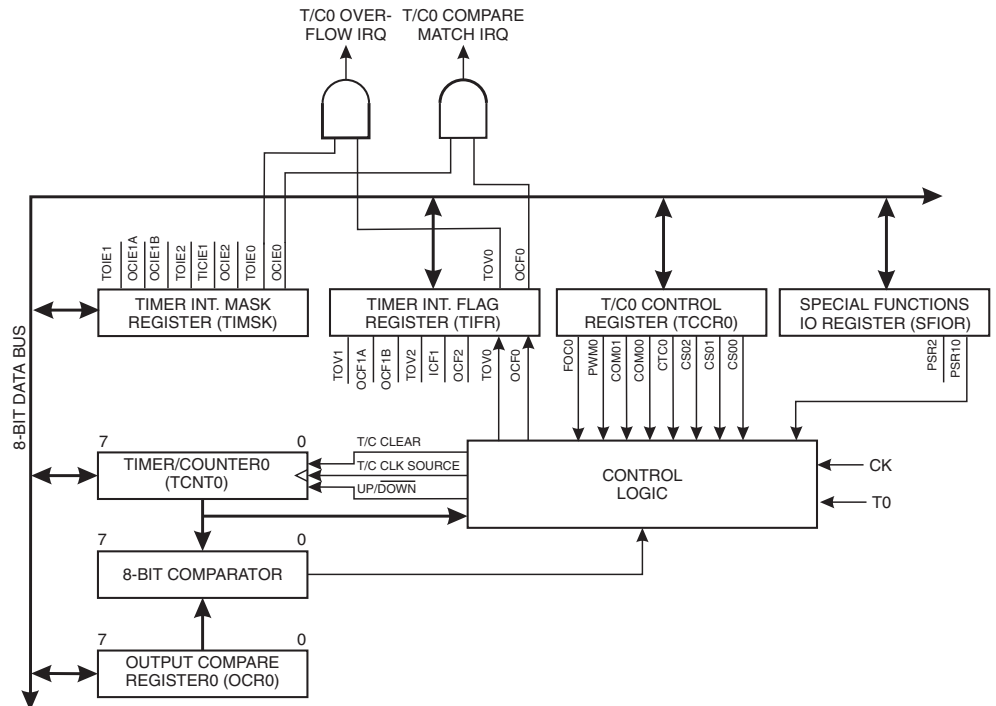
- **Bit 0 – PSR10: Prescaler Reset Timer/Counter1 and Timer/Counter0**

When this bit is set (one), the Timer/Counter1 and Timer/Counter0 prescaler will be reset. The bit will be cleared by hardware after the operation is performed. Writing a zero to this bit will have no effect. Note that Timer/Counter1 and Timer/Counter0 share the same prescaler and a reset of this prescaler will affect both timers. This bit will always be read as zero.

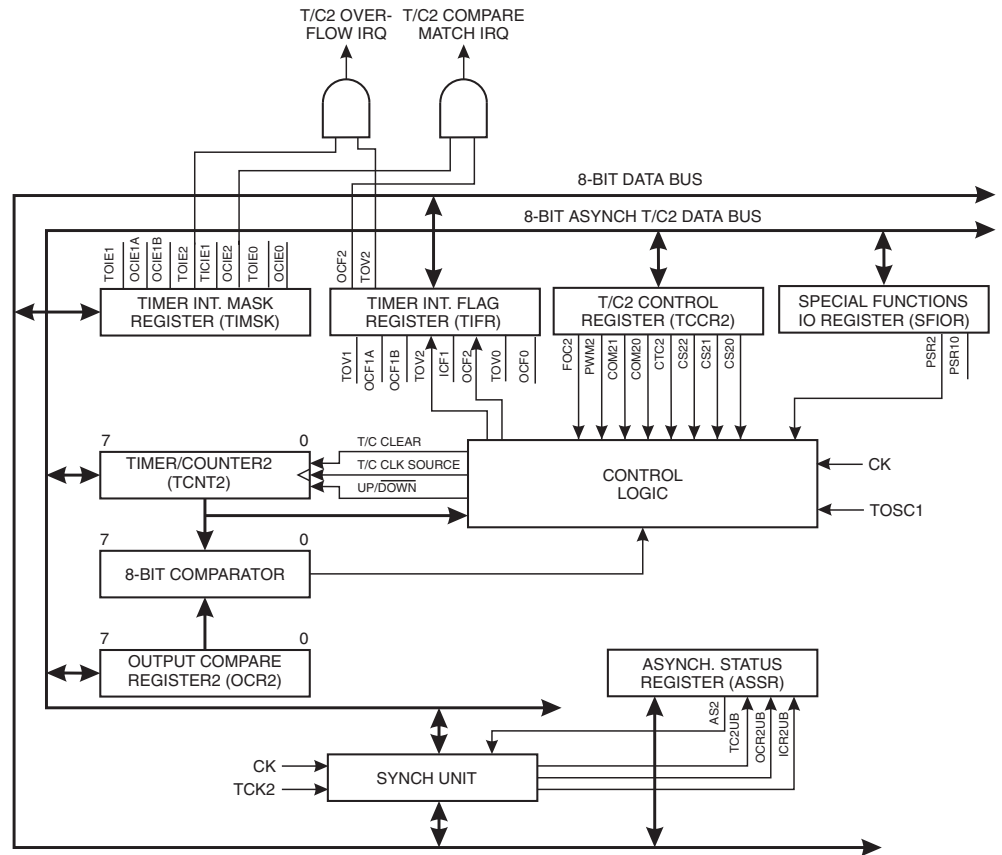
### 8-bit Timer/Counters T/C0 and T/C2

Figure 31 shows the block diagram for Timer/Counter0. Figure 32 shows the block diagram for Timer/Counter2.

**Figure 31.** Timer/Counter0 Block Diagram



**Figure 32. Timer/Counter2 Block Diagram**



The 8-bit Timer/Counter0 can select clock source from CK, prescaled CK or an external pin. The 8-bit Timer/Counter2 can select clock source from CK, prescaled CK or external TOSC1.

Both Timer/Counters can be stopped as described in sections “Timer/Counter0 Control Register - TCCR0” and “Timer/Counter2 Control Register - TCCR2”.

The various Status Flags (Overflow and Compare Match) are found in the Timer/Counter Interrupt Flag Register (TIFR). Control signals are found in the Timer/Counter Control Register (TCCR0 and TCCR2). The interrupt enable/disable settings are found in the Timer/Counter Interrupt Mask Register (TIMSK).

When Timer/Counter0 is externally clocked, the external signal is synchronized with the Oscillator frequency of the CPU. To assure proper sampling of the external clock, the minimum time between two external clock transitions must be at least one internal CPU clock period. The external clock signal is sampled on the rising edge of the internal CPU clock.

The 8-bit Timer/Counters feature both a high resolution and a high accuracy usage with the lower prescaling opportunities. Similarly, the high prescaling opportunities make the Timer/Counter0 useful for lower speed functions or exact timing functions with infrequent actions.

Timer/Counters 0 and 2 can also be used as 8-bit Pulse Width Modulators. In this mode, the Timer/Counter and the Output Compare Register serve as a glitch-free, stand-alone PWM with centered pulses. Refer to page 44 for a detailed description of this function.

### Timer/Counter0 Control Register – TCCR0

Bit	7	6	5	4	3	2	1	0	
\$33 (\$53)	<b>FOC0</b>	<b>PWM0</b>	<b>COM01</b>	<b>COM00</b>	<b>CTC0</b>	<b>CS02</b>	<b>CS01</b>	<b>CS00</b>	TCCR0
Read/Write	R/W	R/W	R/W	R/W	R/W	R/W	R/W	R/W	
Initial Value	0	0	0	0	0	0	0	0	

### Timer/Counter2 Control Register – TCCR2

Bit	7	6	5	4	3	2	1	0	
\$27 (\$47)	<b>FOC2</b>	<b>PWM2</b>	<b>COM21</b>	<b>COM20</b>	<b>CTC2</b>	<b>CS22</b>	<b>CS21</b>	<b>CS20</b>	TCCR2
Read/Write	R/W	R/W	R/W	R/W	R/W	R/W	R/W	R/W	
Initial Value	0	0	0	0	0	0	0	0	

- **Bit 7 – FOC0/FOC2: Force Output Compare**

Writing a logical “1” to this bit forces a change in the compare match output pin PB0 (Timer/Counter0) and PB1 (Timer/Counter2) according to the values already set in COMn1 and COMn0. If the COMn1 and COMn0 bits are written in the same cycle as FOC0/FOC2, the new settings will not take effect until the next compare match or Forced Output Compare Match occurs. The Force Output Compare bit can be used to change the output pin without waiting for a compare match in the timer. The automatic action programmed in COMn1 and COMn0 happens as if a Compare Match had occurred, but no interrupt is generated and the Timer/Counter will not be cleared even if CTC0/CTC2 is set. The FOC0/FOC2 bits will always be read as zero. The setting of the FOC0/FOC2 bits has no effect in PWM mode.

- **Bit 6 – PWM0/PWM2: Pulse Width Modulator Enable**

When set (one), this bit enables PWM mode for Timer/Counter0 or Timer/Counter2. This mode is described on page 44.

- **Bits 5, 4 – COM01, COM00/COM21, COM20: Compare Output Mode, Bits 1 and 0**

The COMn1 and COMn0 control bits determine any output pin action following a compare match in Timer/Counter0 or Timer/Counter2. Output pin actions affect pins PB0(OC0) or PB1(OC2). This is an alternative function to an I/O port and the corresponding direction control bit must be set (one) to control an output pin. The control configuration is shown in Table 9.

**Table 9.** Compare Mode Select<sup>(1)(2)</sup>

COMn1	COMn0	Description
0	0	Timer/Counter disconnected from output pin OCn.
0	1	Toggle the OCn output line.
1	0	Clear the OCn output line (to zero).
1	1	Set the OCn output line (to one).

Notes: 1. In PWM mode, these bits have a different function. Refer to Table 12 for a detailed description.  
2. n = 0 or 2

- **Bit 3 – CTC0/CTC2: Clear Timer/Counter on Compare Match**

When the CTC0 or CTC2 control bit is set (one), Timer/Counter0 or Timer/Counter2 is reset to \$00 in the CPU clock cycle after a compare match. If the control bit is cleared, the Timer/Counter continues counting and is unaffected by a compare match. When a

prescaling of 1 is used, and the compare register is set to C, the timer will count as follows if CTC0/CTC2 is set:

... | C-1 | C | 0 | 1 | ...

When the prescaler is set to divide by 8, the timer will count like this:

... | C-1, C-1, C-1, C-1, C-1, C-1, C-1, C-1 | C, C, C, C, C, C, C, C | 0, 0, 0, 0, 0, 0, 0, 0 | 1, 1, 1, ...

In PWM mode, this bit has a different function. If the CTC0 or CTC2 bit is cleared in PWM mode, the Timer/Counter acts as an up/down counter. If the CTC0 or CTC2 bit is set (one), the Timer/Counter wraps when it reaches \$FF. Refer to page 44 for a detailed description.

- **Bits 2, 1, 0 – CS02, CS01, CS00/CS22, CS21, CS20: Clock Select Bits 2, 1 and 0**

The Clock Select bits 2, 1, and 0 define the prescaling source of Timer/Counter0 and Timer/Counter2.

**Table 10.** Clock 0 Prescale Select

CS02	CS01	CS00	Description
0	0	0	Stop, the Timer/Counter0 is stopped.
0	0	1	CK
0	1	0	CK/8
0	1	1	CK/64
1	0	0	CK/256
1	0	1	CK/1024
1	1	0	External Pin PB0(T0), falling edge
1	1	1	External Pin PB0(T0), rising edge

**Table 11.** Clock 2 Prescale Select

CS22	CS21	CS20	Description
0	0	0	Stop, the Timer/Counter2 is stopped.
0	0	1	PCK2
0	1	0	PCK2/8
0	1	1	PCK2/32
1	0	0	PCK2/64
1	0	1	PCK2/128
1	1	0	PCK2/256
1	1	1	PCK2/1024

The Stop condition provides a Timer Enable/Disable function. The prescaled modes are scaled directly from the CK Oscillator clock for Timer/Counter0 and PCK2 for Timer/Counter2. If the external pin modes are used for Timer/Counter0, transitions on PB0/(T0) will clock the counter even if the pin is configured as an output. This feature can give the user software control of the counting.

### Timer Counter0 – TCNT0

Bit	7	6	5	4	3	2	1	0	
\$32 (\$52)	<b>MSB</b> <span style="display: inline-block; width: 100px; border-bottom: 1px solid black;"></span> <b>LSB</b>								<b>TCNT0</b>
Read/Write	R/W	R/W	R/W	R/W	R/W	R/W	R/W	R/W	
Initial Value	0	0	0	0	0	0	0	0	

### Timer/Counter2 – TCNT2

Bit	7	6	5	4	3	2	1	0	
\$23 (\$43)	<b>MSB</b> <span style="display: inline-block; width: 100px; border-bottom: 1px solid black;"></span> <b>LSB</b>								<b>TCNT2</b>
Read/Write	R/W	R/W	R/W	R/W	R/W	R/W	R/W	R/W	
Initial Value	0	0	0	0	0	0	0	0	

These 8-bit registers contain the value of the Timer/Counters.

Both Timer/Counters are realized as up or up/down (in PWM mode) counters with read and write access. If the Timer/Counter is written to and a clock source is selected, it continues counting in the timer clock cycle following the write operation.

### Timer/Counter0 Output Compare Register – OCR0

Bit	7	6	5	4	3	2	1	0	
\$31 (\$51)	<b>MSB</b> <span style="display: inline-block; width: 100px; border-bottom: 1px solid black;"></span> <b>LSB</b>								<b>OCR0</b>
Read/Write	R/W	R/W	R/W	R/W	R/W	R/W	R/W	R/W	
Initial Value	0	0	0	0	0	0	0	0	

### Timer/Counter2 Output Compare Register – OCR2

Bit	7	6	5	4	3	2	1	0	
\$22 (\$42)	<b>MSB</b> <span style="display: inline-block; width: 100px; border-bottom: 1px solid black;"></span> <b>LSB</b>								<b>OCR2</b>
Read/Write	R/W	R/W	R/W	R/W	R/W	R/W	R/W	R/W	
Initial Value	0	0	0	0	0	0	0	0	

The Output Compare Registers are 8-bit read/write registers. The Timer/Counter Output Compare Registers contain the data to be continuously compared with the Timer/Counter. Actions on compare matches are specified in TCCR0 and TCCR2. A software write to the Timer/Counter Register blocks compare matches in the next Timer/Counter clock cycle. This prevents immediate interrupts when initializing the Timer/Counter.

A compare match will set the Compare Interrupt Flag in the CPU clock cycle following the compare event.

### Timer/Counters 0 and 2 in PWM Mode

When PWM mode is selected, the Timer/Counter either wraps (overflows) when it reaches \$FF or it acts as an up/down counter.

If the up/down mode is selected, the Timer/Counter and the Output Compare Registers (OCR0 or OCR2) form an 8-bit, free-running, glitch-free and phase-correct PWM with outputs on the PB0(OC0/PWM0) or PB1(OC2/PWM2) pin.

If the Overflow mode is selected, the Timer/Counter and the Output Compare Registers (OCR0 or OCR2) form an 8-bit, free-running and glitch-free PWM, operating with twice the speed of the up/down counting mode.

## PWM Modes (Up/Down and Overflow)

The two different PWM modes are selected by the CTC0 or CTC2 bit in the Timer/Counter Control Registers – TCCR0 or TCCR2, respectively.

If CTC0/CTC2 is cleared and PWM mode is selected, the Timer/Counter acts as an up/down counter, counting up from \$00 to \$FF, where it turns and counts down again to zero before the cycle is repeated. When the counter value matches the contents of the Output Compare Register, the PB0(OC0/PWM0) or PB1(OC2/PWM2) pin is set or cleared according to the settings of the COMn1/COMn0 bits in the Timer/Counter Control Registers TCCR0 or TCCR2.

If CTC0/CTC2 is set and PWM mode is selected, the Timer/Counter will wrap and start counting from \$00 after reaching \$FF. The PB0(OC0/PWM0) or PB1(OC2/PWM2) pin will be set or cleared according to the settings of COMn1/COMn0 on a Timer/Counter overflow or when the counter value matches the contents of the Output Compare Register. Refer to Table 12 for details.

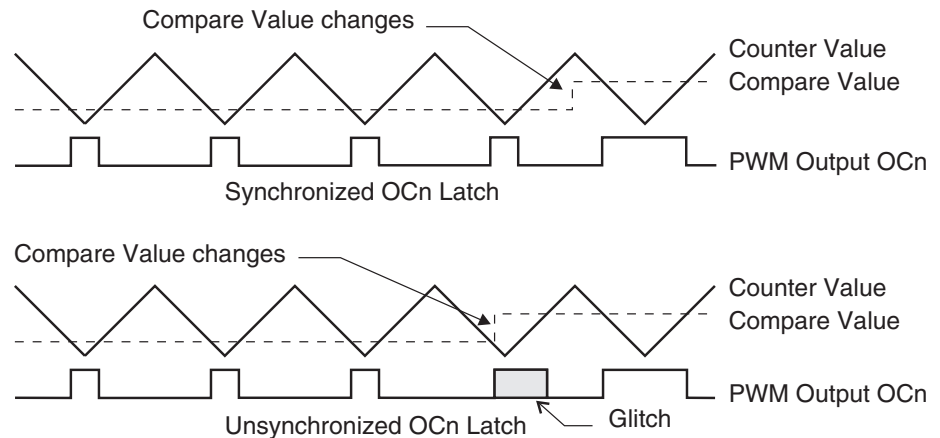
**Table 12.** Compare Mode Select in PWM Mode<sup>(1)</sup>

CTCn	COMn1	COMn0	Effect on Compare Pin	Frequency
0	0	0	Not connected	
0	0	1	Not connected	
0	1	0	Cleared on compare match, up-counting. Set on compare match, down-counting (non-inverted PWM).	$f^{TCK0/2}/510$
0	1	1	Cleared on compare match, down-counting. Set on compare match, up-counting (inverted PWM).	$f^{TCK0/2}/510$
1	0	0	Not connected	
1	0	1	Not connected	
1	1	0	Cleared on compare match, set on overflow	$f^{TCK0/2}/256$
1	1	1	Set on compare match, cleared on overflow	$f^{TCK0/2}/256$

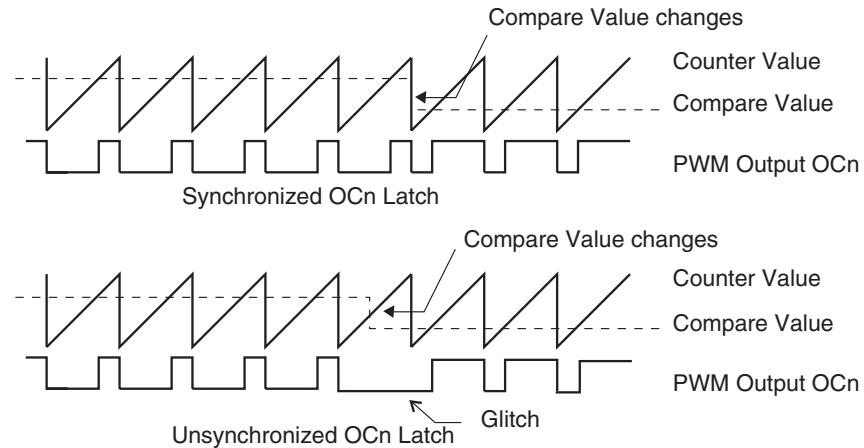
Note: 1. n = 0 or 2

Note that in PWM mode, the value to be written to the Output Compare Register is first transferred to a temporary location and then latched into the OCR when the Timer/Counter reaches \$FF. This prevents the occurrence of odd-length PWM pulses (glitches) in the event of an unsynchronized OCR0 or OCR2 write. See Figure 33 and Figure 34 for examples.

**Figure 33.** Effects of Unsynchronized OCR Latching in Up/Down Mode



**Figure 34.** Effects of Unsynchronized OCR Latching in Overflow Mode.



Note:  $n = 0$  or  $2$  (Figure 33 and Figure 34)

During the time between the write and the latch operation, a read from the Output Compare Registers will read the contents of the temporary location. This means that the most recently written value always will read out of OCR0 and OCR2.

When the Output Compare Register contains \$00 or \$FF, and the up/down PWM mode is selected, the output PB0(OC0/PWM0)/PB1(OC2/PWM2) is updated to low or high on the next compare match according to the settings of COMn1/COMn0. This is shown in Table 13. In overflow PWM mode, the output PB0(OC0/PWM0)/PB1(OC2/PWM2) is held low or high only when the Output Compare Register contains \$FF.

**Table 13.** PWM Outputs OCRn = \$00 or \$FF<sup>(1)(2)</sup>

COMn1	COMn0	OCRn	Output PWMn
1	0	\$00	L
1	0	\$FF	H
1	1	\$00	H
1	1	\$FF	L

Note: 1.  $n = 0$  or  $2$   
 2. In overflow PWM mode, the table above is only valid for OCRn = \$FF.

In up/down PWM mode, the Timer Overflow Flag (TOV0 or TOV2) is set when the counter advances from \$00. In overflow PWM mode, the Timer Overflow Flag is set as in normal Timer/Counter mode. Timer Overflow Interrupt0 and 2 operate exactly as in normal Timer/Counter mode, i.e., they are executed when TOV0 or TOV2 are set, provided that Timer Overflow Interrupt and global interrupts are enabled. This also applies to the Timer Output Compare flag and interrupt.

## Asynchronous Status Register – ASSR

Bit	7	6	5	4	3	2	1	0	
\$26 (\$46)	–	–	–	–	AS2	TCN2UB	OCR2UB	TCR2UB	ASSR
Read/Write	R	R	R	R	R/W	R	R	R	
Initial Value	0	0	0	0	0	0	0	0	

- **Bits 7..4 – Res: Reserved Bits**

These bits are reserved bits in the ATmega161 and always read as zero.

- **Bit 3 – AS2: Asynchronous Timer/Counter2 Mode**

When this bit is cleared (zero), Timer/Counter2 is clocked from the internal system clock, CK. If AS2 is set, the Timer/Counter2 is clocked from the TOSC1 pin. Pins PD4 and PD5 become connected to a crystal Oscillator and cannot be used as general I/O pins. When the value of this bit is changed, the contents of TCNT2, OCR2 and TCCR2 might get corrupted.

- **Bit 2 – TCN2UB: Timer/Counter2 Update Busy**

When Timer/Counter2 operates asynchronously and TCNT2 is written, this bit becomes set (one). When TCNT2 has been updated from the temporary storage register, this bit is cleared (zero) by hardware. A logical “0” in this bit indicates that TCNT2 is ready to be updated with a new value.

- **Bit 1 – OCR2UB: Output Compare Register2 Update Busy**

When Timer/Counter2 operates asynchronously and OCR2 is written, this bit becomes set (one). When OCR2 has been updated from the temporary storage register, this bit is cleared (zero) by hardware. A logical “0” in this bit indicates that OCR2 is ready to be updated with a new value.

- **Bit 0 – TCR2UB: Timer/Counter Control Register2 Update Busy**

When Timer/Counter2 operates asynchronously and TCCR2 is written, this bit becomes set (one). When TCCR2 has been updated from the temporary storage register, this bit is cleared (zero) by hardware. A logical “0” in this bit indicates that TCCR2 is ready to be updated with a new value.

If a write is performed to any of the three Timer/Counter2 Registers while its update Busy Flag is set (one), the updated value might get corrupted and cause an unintentional interrupt to occur.

The mechanisms for reading TCNT2, OCR2 and TCCR2 are different. When reading TCNT2, the actual timer value is read. When reading OCR2 or TCCR2, the value in the temporary storage register is read.

## Asynchronous Operation of Timer/Counter2

When Timer/Counter2 operates asynchronously, some considerations must be taken:

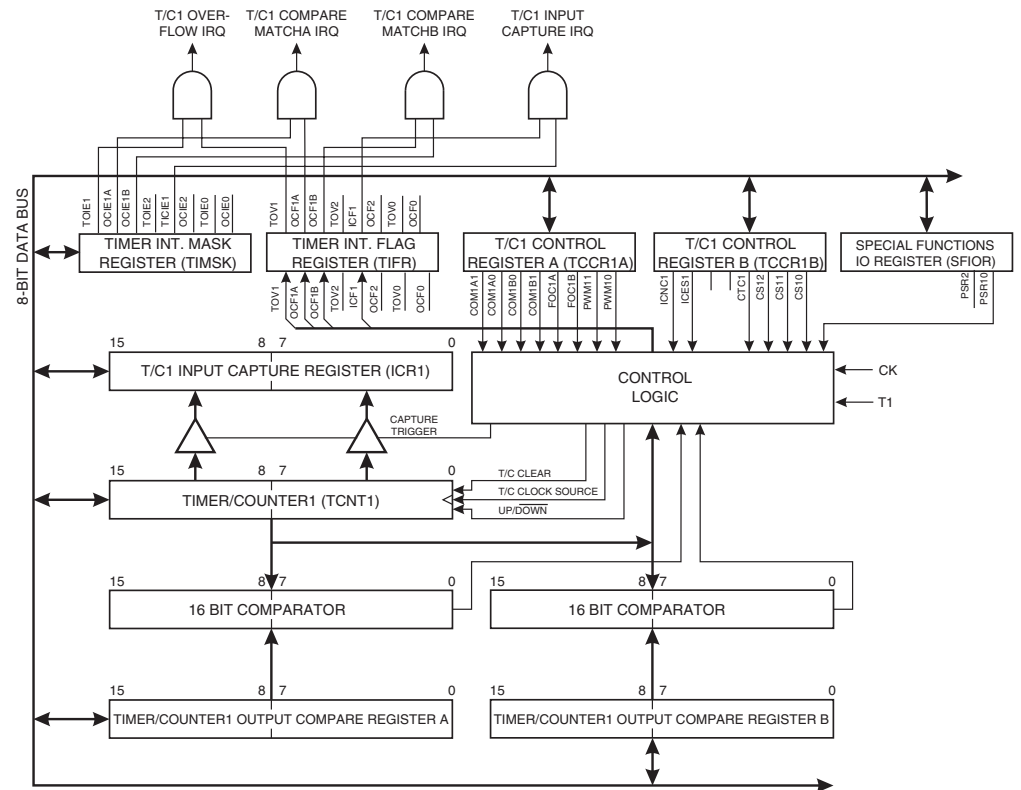
- **Warning:** When switching between asynchronous and synchronous clocking of Timer/Counter2, the Timer Registers TCNT2, OCR2, and TCCR2 might get corrupted. A safe procedure for switching clock source is:
  1. Disable the Timer/Counter2 interrupts by clearing OCIE2 and TOIE2.
  2. Select clock source by setting AS2 as appropriate.
  3. Write new values to TCNT2, OCR2, and TCCR2.
  4. To switch to asynchronous operation: Wait for TCN2UB, OCR2UB, and TCR2UB.
  5. Enable interrupts, if needed.
- The Oscillator is optimized for use with a 32,768 Hz watch crystal. An external clock signal applied to this pin goes through the same amplifier having a bandwidth of 256 kHz. The external clock signal should therefore be in the interval 0 Hz - 256 kHz. The frequency of the clock signal applied to the TOSC1 pin must be lower than one fourth of the CPU main clock frequency.
- When writing to one of the registers TCNT2, OCR2, or TCCR2, the value is transferred to a temporary register, and latched after two positive edges on TOSC1. The user should not write a new value before the contents of the temporary register have been transferred to its destination. Each of the three mentioned registers have their individual temporary register, which means that e.g., writing to TCNT2 does not disturb an OCR2 write in progress. To detect that a transfer to the destination register has taken place, a Asynchronous Status Register – ASSR has been implemented.
- When entering Power-save mode after having written to TCNT2, OCR2 or TCCR2, the user must wait until the written register has been updated if Timer/Counter2 is used to wake up the device. Otherwise, the MCU will go to sleep before the changes have had any effect. This is extremely important if the Output Compare2 interrupt is used to wake up the device; output compare is disabled during write to OCR2 or TCNT2. If the write cycle is not finished (i.e., the MCU enters sleep mode before the OCR2UB bit returns to zero), the device will never get a compare match and the MCU will not wake up.
- If Timer/Counter2 is used to wake up the device from Power-save mode, precautions must be taken if the user wants to re-enter Power-save mode: The interrupt logic needs one TOSC1 cycle to be reset. If the time between wake-up and re-entering Power-save mode is less than one TOSC1 cycle, the interrupt will not occur and the device will fail to wake up. If the user is in doubt whether the time before re-entering Power-save is sufficient, the following algorithm can be used to ensure that one TOSC1 cycle has elapsed:
  1. Write a value to TCCR2, TCNT2, or OCR2.
  2. Wait until the corresponding Update Busy Flag in ASSR returns to zero.
  3. Enter Power-save mode.
- When asynchronous operation is selected, the 32 kHz Oscillator for Timer/Counter2 is always running, except in Power-down mode. After a Power-up Reset or wake-up from power-down, the user should be aware of the fact that this Oscillator might take as long as one second to stabilize. The user is advised to wait for at least one second before using Timer/Counter2 after power-up or wake-up from power-down. The contents of all Timer/Counter2 Registers must be considered lost after a wake-up from power-down, due to unstable clock signal upon start-up, regardless of whether the Oscillator is in use or a clock signal is applied to the TOSC pin.

- Description of wake-up from Power-save mode when the timer is clocked asynchronously: When the interrupt condition is met, the wake-up process is started on the following cycle of the timer clock, that is, the timer is always advanced by at least 1 before the processor can read the counter value. The Interrupt Flags are updated three processor cycles after the processor clock has started. During these cycles, the processor executes instructions, but the interrupt condition is not readable and the interrupt routine has not started yet.
- During asynchronous operation, the synchronization of the Interrupt Flags for the asynchronous timer takes three processor cycles plus one timer cycle. The timer is therefore advanced by at least 1 before the processor can read the timer value, causing the setting of the Interrupt Flag. The output compare pin is changed on the timer clock and is not synchronized to the processor clock.

## Timer/Counter1

Figure 35 shows the block diagram for Timer/Counter1.

**Figure 35.** Timer/Counter1 Block Diagram



The 16-bit Timer/Counter1 can select clock source from CK, prescaled CK or an external pin. In addition, it can be stopped as described in “Timer/Counter1 Control Register B – TCCR1B”. The different Status Flags (Overflow, Compare Match, and Capture Event) are found in the Timer/Counter Interrupt Flag Register (TIFR). Control signals are found in the Timer/Counter1 Control Registers (TCCR1A and TCCR1B). The interrupt enable/disable settings for Timer/Counter1 are found in the Timer/Counter Interrupt Mask Register (TIMSK).

When Timer/Counter1 is externally clocked, the external signal is synchronized with the Oscillator frequency of the CPU. To assure proper sampling of the external clock, the minimum time between two external clock transitions must be at least one internal CPU

clock period. The external clock signal is sampled on the rising edge of the internal CPU clock.

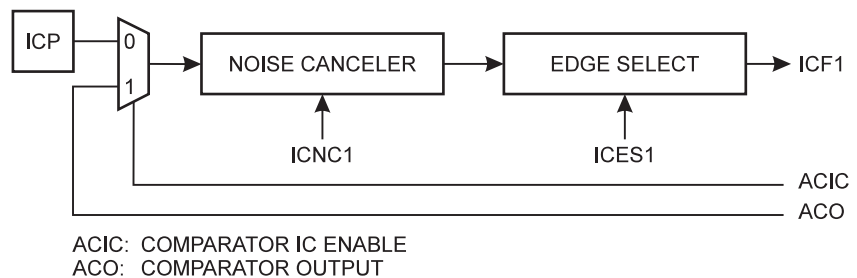
The 16-bit Timer/Counter1 features both a high-resolution and a high-accuracy usage with the lower prescaling opportunities. Similarly, the high-prescaling opportunities make the Timer/Counter1 useful for lower speed functions or exact timing functions with infrequent actions.

The Timer/Counter1 supports two Output Compare functions using the Output Compare Register 1 A and B (OCR1A and OCR1B) as the data sources to be compared to the Timer/Counter1 contents. The Output Compare functions include optional clearing of the counter on compareA match and actions on the Output Compare pins on both compare matches.

Timer/Counter1 can also be used as an 8-, 9-, or 10-bit Pulse Width Modulator. In this mode the counter and the OCR1A/OCR1B Registers serve as a dual glitch-free stand-alone PWM with centered pulses. Alternatively, the Timer/Counter1 can be configured to operate at twice the speed in PWM mode, but without centered pulses. Refer to page 55 for a detailed description of this function.

The Input Capture function of Timer/Counter1 provides a capture of the Timer/Counter1 contents to the Input Capture Register (ICR1), triggered by an external event on the Input Capture Pin (ICP). The actual capture event settings are defined by the Timer/Counter1 Control Register (TCCR1B). In addition, the Analog Comparator can be set to trigger the Input Capture. Refer to the section, “The Analog Comparator”, for details on this. The ICP pin logic is shown in Figure 36.

**Figure 36.** ICP Pin Schematic Diagram



If the noise canceler function is enabled, the actual trigger condition for the Capture Event is monitored over four samples, and all four must be equal to activate the Capture Flag.

**Timer/Counter1 Control Register A – TCCR1A**

Bit	7	6	5	4	3	2	1	0	
\$2F (\$4F)	COM1A1	COM1A0	COM1B1	COM1B0	FOC1A	FOC1B	PWM11	PWM10	TCCR1A
Read/Write	R/W	R/W	R/W	R/W	R/w	R/W	R/W	R/W	
Initial Value	0	0	0	0	0	0	0	0	

• **Bits 7, 6 – COM1A1, COM1A0: Compare Output Mode1A, Bits 1 and 0**

The COM1A1 and COM1A0 control bits determine any output pin action following a compare match in Timer/Counter1. Any output pin actions affect pin OC1A (Output CompareA pin 1). This is an alternative function to an I/O port, and the corresponding direction control bit must be set (one) to control an output pin. The control configuration is shown in Table 14.

- **Bits 5, 4 – COM1B1, COM1B0: Compare Output Mode1B, Bits 1 and 0**

The COM1B1 and COM1B0 control bits determine any output pin action following a compare match in Timer/Counter1. Any output pin actions affect pin OC1B (Output CompareB). This is an alternative function to an I/O port, and the corresponding direction control bit must be set (one) to control an output pin. The following control configuration is given:

**Table 14.** Compare 1 Mode Select<sup>(1)</sup>

COM1X1	COM1X0	Description
0	0	Timer/Counter1 disconnected from output pin OC1X
0	1	Toggle the OC1X output line.
1	0	Clear the OC1X output line (to zero).
1	1	Set the OC1X output line (to one).

Note: 1. X = A or B

In PWM mode, these bits have a different function. Refer to Table 18 for a detailed description.

- **Bit 3 – FOC1A: Force Output Compare1A**

Writing a logical “1” to this bit forces a change in the compare match output pin PD5 according to the values already set in COM1A1 and COM1A0. If the COM1A1 and COM1A0 bits are written in the same cycle as FOC1A, the new settings will not take effect until the next compare match or forced compare match occurs. The Force Output Compare bit can be used to change the output pin without waiting for a compare match in the timer. The automatic action programmed in COM1A1 and COM1A0 happens as if a Compare Match had occurred, but no interrupt is generated and it will not clear the timer even if CTC1 in TCCR1B is set. The FOC1A bit will always be read as zero. The setting of the FOC1A bit has no effect in PWM mode.

- **Bit 2 – FOC1B: Force Output Compare1B**

Writing a logical “1” to this bit forces a change in the compare match output pin PE2 according to the values already set in COM1B1 and COM1B0. If the COM1B1 and COM1B0 bits are written in the same cycle as FOC1B, the new settings will not take effect until the next compare match or forced compare match occurs. The Force Output Compare bit can be used to change the output pin without waiting for a compare match in the timer. The automatic action programmed in COM1B1 and COM1B0 happens as if a Compare Match had occurred, but no interrupt is generated. The FOC1B bit will always be read as zero. The setting of the FOC1B bit has no effect in PWM mode.

- **Bits 1..0 – PWM11, PWM10: Pulse Width Modulator Select Bits**

These bits select PWM operation of Timer/Counter1 as specified in Table 15. This mode is described on page 55.

**Table 15.** PWM Mode Select

PWM11	PWM10	Description
0	0	PWM operation of Timer/Counter1 is disabled.
0	1	Timer/Counter1 is an 8-bit PWM.
1	0	Timer/Counter1 is a 9-bit PWM.
1	1	Timer/Counter1 is a 10-bit PWM.

**Timer/Counter1 Control Register B – TCCR1B**

Bit	7	6	5	4	3	2	1	0	
\$2E (\$4E)	ICNC1	ICES1	–	–	CTC1	CS12	CS11	CS10	TCCR1B
Read/Write	R/W	R/W	R	R	R/W	R/W	R/W	R/W	
Initial Value	0	0	0	0	0	0	0	0	

- **Bit 7 – ICNC1: Input Capture1 Noise Canceler (4 CKs)**

When the ICNC1 bit is cleared (zero), the Input Capture trigger noise canceler function is disabled. The Input Capture is triggered at the first rising/falling edge sampled on the ICP (Input Capture pin) as specified. When the ICNC1 bit is set (one), four successive samples are measured on the ICP (Input Capture pin), and all samples must be high/low according to the Input Capture trigger specification in the ICES1 bit. The actual sampling frequency is XTAL clock frequency.

- **Bit 6 – ICES1: Input Capture1 Edge Select**

While the ICES1 bit is cleared (zero), the Timer/Counter1 contents are transferred to the Input Capture Register (ICR1) on the falling edge of the Input Capture pin (ICP). While the ICES1 bit is set (one), the Timer/Counter1 contents are transferred to the Input Capture Register (ICR1) on the rising edge of the Input Capture pin (ICP).

- **Bits 5, 4 – Res: Reserved Bits**

These bits are reserved bits in the ATmega161 and always read as zero.

- **Bit 3 – CTC1: Clear Timer/Counter1 on Compare Match**

When the CTC1 control bit is set (one), the Timer/Counter1 is reset to \$0000 in the clock cycle after a compareA match. If the CTC1 control bit is cleared, Timer/Counter1 continues counting and is unaffected by a compare match. When a prescaling of 1 is used and the Compare A Register is set to C, the timer will count as follows if CTC1 is set:

... | C-1 | C | 0 | 1 | ...

When the prescaler is set to divide by 8, the timer will count like this:

... | C-1, C-1, C-1, C-1, C-1, C-1, C-1, C-1 | C, C, C, C, C, C, C, C | 0, 0, 0, 0, 0, 0, 0, 0 | ...

In PWM mode, this bit has a different function. If the CTC1 bit is cleared in PWM mode, the Timer/Counter1 acts as an up/down counter. If the CTC1 bit is set (one), the Timer/Counter wraps when it reaches the TOP value. Refer to page 55 for a detailed description.

- **Bits 2, 1, 0 – CS12, CS11, CS10: Clock Select1, Bits 2, 1 and 0**

The Clock Select1 bits 2, 1 and 0 define the prescaling source of Timer/Counter1.

**Table 16.** Clock 1 Prescale Select

CS12	CS11	CS10	Description
0	0	0	Stop, the Timer/Counter1 is stopped.
0	0	1	CK
0	1	0	CK/8
0	1	1	CK/64
1	0	0	CK/256
1	0	1	CK/1024
1	1	0	External Pin T1, falling edge
1	1	1	External Pin T1, rising edge

The Stop condition provides a Timer Enable/Disable function. The CK down divided modes are scaled directly from the CK Oscillator clock. If the external pin modes are used for Timer/Counter1, transitions on PB1/(T1) will clock the counter even if the pin is configured as an output. This feature can give the user software control of the counting.

## Timer/Counter1 Register – TCNT1H AND TCNT1L

Bit	15	14	13	12	11	10	9	8		
\$2D (\$4D)	<b>MSB</b>									TCNT1H TCNT1L
\$2C (\$4C)								<b>LSB</b>		
Read/Write	R/W	R/W	R/W	R/W	R/W	R/W	R/W	R/W		
Initial Value	0	0	0	0	0	0	0	0		

This 16-bit register contains the prescaled value of the 16-bit Timer/Counter1. To ensure that both the high and low bytes are read and written simultaneously when the CPU accesses these registers, the access is performed using an 8-bit temporary register (TEMP). This temporary register is also used when accessing OCR1A, OCR1B, and ICR1. If the main program and interrupt routines perform access to registers using TEMP, interrupts must be disabled during access from the main program and interrupt routines.

- **TCNT1 Timer/Counter1 Write**

When the CPU writes to the High byte TCNT1H, the written data is placed in the TEMP Register. Next, when the CPU writes the Low byte TCNT1L, this byte of data is combined with the byte data in the TEMP Register and all 16 bits are written to the TCNT1 Timer/Counter1 Register simultaneously. Consequently, the High byte TCNT1H must be accessed first for a full 16-bit register write operation.

- **TCNT1 Timer/Counter1 Read**

When the CPU reads the Low byte TCNT1L, the data of the Low byte TCNT1L is sent to the CPU and the data of the High byte TCNT1H is placed in the TEMP Register. When the CPU reads the data in the High byte TCNT1H, the CPU receives the data in the TEMP Register. Consequently, the Low byte TCNT1L must be accessed first for a full 16-bit register read operation.

The Timer/Counter1 is realized as an up or up/down (in PWM mode) counter with read and write access. If Timer/Counter1 is written to and a clock source is selected, the Timer/Counter1 continues counting in the timer clock cycle after it is preset with the written value.

**Timer/Counter1 Output Compare Register – OCR1AH AND OCR1AL**

Bit	15	14	13	12	11	10	9	8		
\$2B (\$4B)	<b>MSB</b>									<b>OCR1AH</b>
\$2A (\$4A)								<b>LSB</b>	<b>OCR1AL</b>	
	7	6	5	4	3	2	1	0		
Read/Write	R/W	R/W	R/W	R/W	R/W	R/W	R/W	R/W	R/W	
	R/W	R/W	R/W	R/W	R/W	R/W	R/W	R/W	R/W	
Initial Value	0	0	0	0	0	0	0	0	0	
	0	0	0	0	0	0	0	0	0	

**Timer/Counter1 Output Compare Register – OCR1BH AND OCR1BL**

Bit	15	14	13	12	11	10	9	8		
\$29 (\$49)	<b>MSB</b>									<b>OCR1BH</b>
\$28 (\$48)								<b>LSB</b>	<b>OCR1BL</b>	
	7	6	5	4	3	2	1	0		
Read/Write	R/W	R/W	R/W	R/W	R/W	R/W	R/W	R/W	R/W	
	R/W	R/W	R/W	R/W	R/W	R/W	R/W	R/W	R/W	
Initial Value	0	0	0	0	0	0	0	0	0	
	0	0	0	0	0	0	0	0	0	

The Output Compare Registers are 16-bit read/write registers.

The Timer/Counter1 Output Compare Registers contain the data to be continuously compared with Timer/Counter1. Actions on compare matches are specified in the Timer/Counter1 Control and Status Registers. A software write to the Timer/Counter Register blocks compare matches in the next Timer/Counter clock cycle. This prevents immediate interrupts when initializing the Timer/Counter.

A compare match will set the Compare Interrupt Flag in the CPU clock cycle following the compare event.

Since the Output Compare Registers (OCR1A and OCR1B) are 16-bit registers, a temporary register (TEMP) is used when OCR1A/B are written to ensure that both bytes are updated simultaneously. When the CPU writes the High byte, OCR1AH or OCR1BH, the data is temporarily stored in the TEMP Register. When the CPU writes the Low byte, OCR1AL or OCR1BL, the TEMP Register is simultaneously written to OCR1AH or OCR1BH. Consequently, the High byte OCR1AH or OCR1BH must be written first for a full 16-bit register write operation.

The TEMP Register is also used when accessing TCNT1 and ICR1. If the main program and interrupt routines perform access to registers using TEMP, interrupts must be disabled during access from the main program and interrupt routines.

**Timer/Counter1 Input Capture Register – ICR1H AND ICR1L**

Bit	15	14	13	12	11	10	9	8		
\$25 (\$45)	<b>MSB</b>									<b>ICR1H</b>
\$24 (\$44)								<b>LSB</b>	<b>ICR1L</b>	
	7	6	5	4	3	2	1	0		
Read/Write	R	R	R	R	R	R	R	R	R	
	R	R	R	R	R	R	R	R	R	
Initial Value	0	0	0	0	0	0	0	0	0	
	0	0	0	0	0	0	0	0	0	

The Input Capture Register is a 16-bit read-only register.

When the rising or falling edge (according to the Input Capture edge setting, ICES1) of the signal at the Input Capture pin (ICP) is detected, the current value of the Timer/Counter1 Register (TCNT1) is transferred to the Input Capture Register (ICR1). In the same cycle, the Input Capture Flag (ICF1) is set (one).

Since the Input Capture Register (ICR1) is a 16-bit register, a temporary register (TEMP) is used when ICR1 is read to ensure that both bytes are read simultaneously. When the CPU reads the Low byte ICR1L, the data is sent to the CPU and the data of the High byte ICR1H is placed in the TEMP Register. When the CPU reads the data in the High byte ICR1H, the CPU receives the data in the TEMP Register. Consequently, the Low byte ICR1L must be accessed first for a full 16-bit register read operation.

The TEMP Register is also used when accessing TCNT1, OCR1A and OCR1B. If the main program and interrupt routines perform access to registers using TEMP, interrupts must be disabled during access from the main program and interrupt routine.

## Timer/Counter1 in PWM Mode

When the PWM mode is selected, Timer/Counter1 and the Output Compare Register1A (OCR1A) and the Output Compare Register1B (OCR1B) form a dual 8-, 9-, or 10-bit, free-running, glitch-free, and phase-correct PWM with outputs on the PD5(OC1A) and PE2(OC1B) pins. In this mode the Timer/Counter1 acts as an up/down counter, counting up from \$0000 to TOP (see Table 17), where it turns and counts down again to zero before the cycle is repeated. When the counter value matches the contents of the 8, 9, or 10 least significant bits (depends of the resolution) of OCR1A or OCR1B, the PD5(OC1A)/PE2(OC1B) pins are set or cleared according to the settings of the COM1A1/COM1A0 or COM1B1/COM1B0 bits in the Timer/Counter1 Control Register (TCCR1A). Refer to Table 18 for details.

Alternatively, the Timer/Counter1 can be configured to a PWM that operates at twice the speed as in the mode described above. Then the Timer/Counter1 and the Output Compare Register1A (OCR1A) and the Output Compare Register1B (OCR1B) form a dual 8-, 9- or 10-bit, free-running and glitch-free PWM with outputs on the PD5(OC1A) and PE2(OC1B) pins.

**Table 17.** Timer TOP Values and PWM Frequency

CTC1	PWM11	PWM10	PWM Resolution	Timer TOP Value	Frequency
0	0	1	8-bit	\$00FF (255)	$f_{TCK1}/510$
0	1	0	9-bit	\$01FF (511)	$f_{TCK1}/1022$
0	1	1	10-bit	\$03FF (1023)	$f_{TCK1}/2046$
1	0	1	8-bit	\$00FF (255)	$f_{TCK1}/256$
1	1	0	9-bit	\$01FF (511)	$f_{TCK1}/512$
1	1	1	10-bit	\$03FF (1023)	$f_{TCK1}/1024$

As shown in Table 17, the PWM operates at either 8-, 9-, or 10-bit resolution. Note the unused bits in OCR1A, OCR1B and TCNT1 will automatically be written to zero by hardware, i.e., bits 9 to 15 will be set to zero in OCR1A, OCR1B and TCNT1 if the 9-bit PWM resolution is selected. This makes it possible for the user to perform read-modify-write operations in any of the three resolution modes and the unused bits will be treated as don't care.

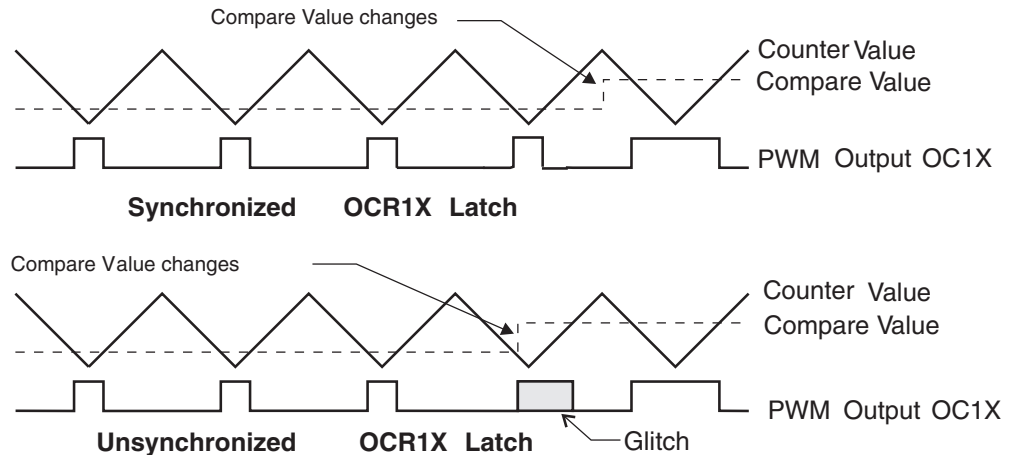
**Table 18.** Compare1 Mode Select in PWM Mode<sup>(1)</sup>

CTC1	COM1X1	COM1X0	Effect on OCX1
0	0	0	Not connected
0	0	1	Not connected
0	1	0	Cleared on compare match, up-counting. Set on compare match, down-counting (non-inverted PWM).
0	1	1	Cleared on compare match, down-counting. Set on compare match, up-counting (inverted PWM).
1	0	0	Not connected
1	0	1	Not connected
1	1	0	Cleared on compare match, set on overflow.
1	1	1	Set on compare match, cleared on overflow.

Note: 1. X = A or B

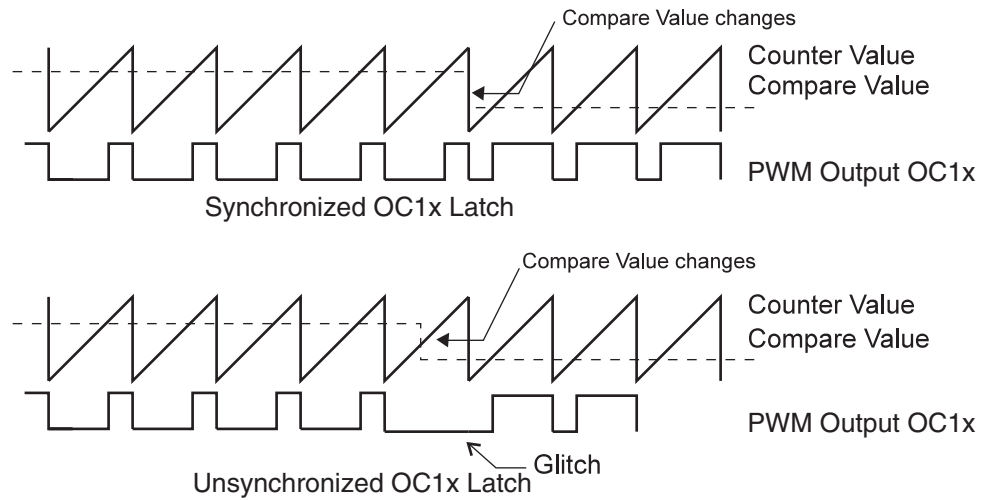
Note that in the PWM mode, the 8, 9 or 10 least significant OCR1A/OCR1B bits (depends of resolution), when written, are transferred to a temporary location. They are latched when Timer/Counter1 reaches the value TOP. This prevents the occurrence of odd-length PWM pulses (glitches) in the event of an unsynchronized OCR1A/OCR1B write. See Figure 37 and Figure 38 for an example in each mode.

**Figure 37.** Effects on Unsynchronized OCR1 Latching<sup>(1)</sup>



Note: 1. Note: X = A or B

**Figure 38.** Effects of Unsynchronized OCR1 Latching in Overflow Mode<sup>1</sup>



Note: 1. Note: X = A or B

During the time between the write and the latch operation, a read from OCR1A or OCR1B will read the contents of the temporary location. This means that the most recently written value always will read out of OCR1A/B.

When the OCR1X contains \$0000 or TOP, and the up/down PWM mode is selected, the output OC1A/OC1B is updated to low or high on the next compare match according to the settings of COM1A1/COM1A0 or COM1B1/COM1B0. This is shown in Table 19. In overflow PWM mode, the output OC1A/OC1B is held low or high only when the Output Compare Register contains TOP.

**Table 19.** PWM Outputs OCR1X = \$0000 or TOP<sup>(1)</sup>

COM1X1	COM1X0	OCR1X	Output OC1X
1	0	\$0000	L
1	0	TOP	H
1	1	\$0000	H
1	1	TOP	L

Note: 1. X = A or B

In overflow PWM mode, the table above is only valid for OCR1X = TOP.

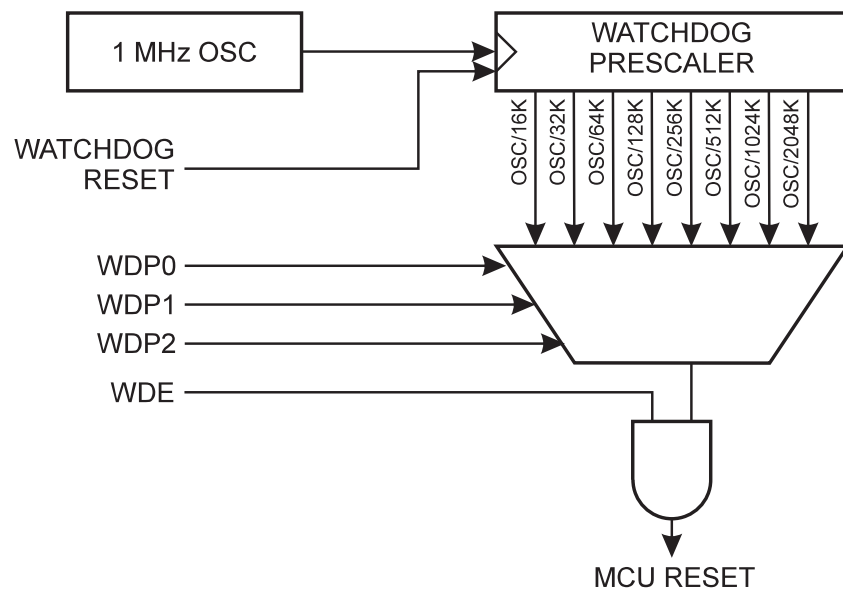
In up/down PWM mode, the Timer Overflow Flag1 (TOV1) is set when the counter advances from \$0000. In overflow PWM mode, the Timer Overflow Flag is set as in normal Timer/Counter mode. Timer Overflow Interrupt1 operates exactly as in normal Timer/Counter mode, i.e., it is executed when TOV1 is set, provided that Timer Overflow Interrupt1 and global interrupts are enabled. This also applies to the Timer Output Compare1 Flags and interrupts.

## Watchdog Timer

The Watchdog Timer is clocked from a separate On-chip Oscillator that runs at 1 MHz. This is the typical value at  $V_{CC} = 5V$ . See characterization data for typical values at other  $V_{CC}$  levels. By controlling the Watchdog Timer prescaler, the Watchdog Reset interval can be adjusted (see Table 20 for a detailed description). The WDR (Watchdog Reset) instruction resets the Watchdog Timer. Eight different clock cycle periods can be selected to determine the reset period. If the reset period expires without another Watchdog Reset, the ATmega161 resets and executes from the Reset Vector. For timing details on the Watchdog Reset, refer to page 28.

To prevent unintentional disabling of the Watchdog, a special turn-off sequence must be followed when the Watchdog is disabled. Refer to the description of the Watchdog Timer Control Register for details.

**Figure 39.** Watchdog Timer



### Watchdog Timer Control Register – WDTCR

Bit	7	6	5	4	3	2	1	0	
\$21 (\$41)	–	–	–	WDTOE	WDE	WDP2	WDP1	WDP0	WDTCR
Read/Write	R	R	R	R/W	R/W	R/W	R/W	R/W	
Initial Value	0	0	0	0	0	0	0	0	

- **Bits 7..5 – Res: Reserved Bits**

These bits are reserved bits in the ATmega161 and will always read as zero.

- **Bit 4 – WDTOE: Watchdog Turn-off Enable**

This bit must be set (one) when the WDE bit is cleared. Otherwise, the Watchdog will not be disabled. Once set, hardware will clear this bit to zero after four clock cycles. Refer to the description of the WDE bit for a Watchdog disable procedure.

- **Bit 3 – WDE: Watchdog Enable**

When the WDE is set (one), the Watchdog Timer is enabled and if the WDE is cleared (zero), the Watchdog Timer function is disabled. WDE can only be cleared if the

WDTOE bit is set (one). To disable an enabled Watchdog Timer, the following procedure must be followed:

1. In the same operation, write a logical “1” to WDTOE and WDE. A logical “1” must be written to WDE even though it is set to one before the disable operation starts.
2. Within the next four clock cycles, write a logical “0” to WDE. This disables the Watchdog.

• **Bits 2..0 – WDP2, WDP1, WDP0: Watchdog Timer Prescaler 2, 1 and 0**

The WDP2, WDP1 and WDP0 bits determine the Watchdog Timer prescaling when the Watchdog Timer is enabled. The different prescaling values and their corresponding time-out periods are shown in Table 20.

**Table 20.** Watchdog Timer Prescale Select <sup>(1)</sup>

WDP2	WDP1	WDP0	Number of WDT Oscillator Cycles	Typical Time-out at V <sub>CC</sub> = 3.0V	Typical Time-out at V <sub>CC</sub> = 5.0V
0	0	0	16K	47 ms	15 ms
0	0	1	32K	94 ms	30 ms
0	1	0	64K	0.19 s	60 ms
0	1	1	128K	0.38 s	0.12 s
1	0	0	256K	0.75 s	0.24 s
1	0	1	512K	1.5 s	0.49 s
1	1	0	1,024K	3.0 s	0.97 s
1	1	1	2,048K	6.0 s	1.9 s

- Note: 1. The frequency of the Watchdog Oscillator is voltage-dependent, as shown in the Electrical Characteristics section.
- The WDR (Watchdog Reset) instruction should always be executed before the Watchdog Timer is enabled. This ensures that the reset period will be in accordance with the Watchdog Timer prescale settings. If the Watchdog Timer is enabled without reset, the Watchdog Timer may not start counting from zero.
- To avoid unintentional MCU Reset, the Watchdog Timer should be disabled or reset before changing the Watchdog Timer Prescale Select.

## EEPROM Read/Write Access

The EEPROM Access Registers are accessible in the I/O space.

The write access time is in the range of 1.9 - 3.4 ms, depending on the frequency of the RC Oscillator used to time the EEPROM access time. See Table 22 for details. A self-timing function, however, lets the user software detect when the next byte can be written. If the user code contains code that writes the EEPROM, some precaution must be taken. In heavily filtered power supplies,  $V_{CC}$  is likely to rise or fall slowly on power-up/down. This causes the device for some period of time to run at a voltage lower than specified as minimum for the clock frequency used. CPU operation under these conditions is likely cause the Program Counter to perform unintentional jumps and eventually execute the EEPROM write code. To secure EEPROM integrity, the user is advised to use an external Under-voltage Reset circuit in this case.

In order to prevent unintentional EEPROM writes, a specific write procedure must be followed. Refer to the description of the EEPROM Control Register for details on this.

When the EEPROM is written, the CPU is halted for two clock cycles before the next instruction is executed. When the EEPROM is read, the CPU is halted for four clock cycles before the next instruction is executed.

### EEPROM Address Register – EEARH and EEARL

Bit	15	14	13	12	11	10	9	8	
\$1F (\$3F)	–	–	–	–	–	–	–	EEAR8	EEARH
\$1E (\$3E)	EEAR7	EEAR6	EEAR5	EEAR4	EEAR3	EEAR2	EEAR1	EEAR0	EEARL
	7	6	5	4	3	2	1	0	
Read/Write	R	R	R	R	R	R	R	R/W	
	R/W	R/W	R/W	R/W	R/W	R/W	R/W	R/W	
Initial Value	0	0	0	0	0	0	0	X	
	X	X	X	X	X	X	X	X	

- **Bits 15..9 – Res: Reserved Bits**

These bits are reserved bits in the ATmega161 and will always read as zero.

- **Bits 8..0 – EEAR8..0: EEPROM Address**

The EEPROM Address Registers (EEARH and EEARL) specify the EEPROM address in the 512-byte EEPROM space. The EEPROM data bytes are addressed linearly between 0 and 511. The initial value of EEAR is undefined. A proper value must be written before the EEPROM may be accessed.

### EEPROM Data Register – EEDR

Bit	7	6	5	4	3	2	1	0	
\$1D (\$3D)	MSB							LSB	EEDR
Read/Write	R/W	R/W	R/W	R/W	R/W	R/W	R/W	R/W	
Initial Value	0	0	0	0	0	0	0	0	

- **Bits 7..0 – EEDR7..0: EEPROM Data**

For the EEPROM write operation, the EEDR Register contains the data to be written to the EEPROM in the address given by the EEAR Register. For the EEPROM read operation, the EEDR contains the data read out from the EEPROM at the address given by EEAR.

## EEPROM Control Register – EECR

Bit	7	6	5	4	3	2	1	0	
\$1C (\$3C)	–	–	–	–	EERIE	EEMWE	EEWE	EERE	EECR
Read/Write	R	R	R	R	R/W	R/W	R/W	R/W	
Initial Value	0	0	0	0	0	0	X	0	

- **Bits 7..4 – Res: Reserved Bits**

These bits are reserved bits in the ATmega161 and will always read as zero.

- **Bit 3 – EERIE: EEPROM Ready Interrupt Enable**

When the I-bit in SREG and EERIE are set (one), the EEPROM Ready Interrupt is enabled. When cleared (zero), the interrupt is disabled. The EEPROM Ready interrupt generates a constant interrupt when EEWE is cleared (zero).

- **Bit 2 – EEMWE: EEPROM Master Write Enable**

The EEMWE bit determines whether setting EEWE to one causes the EEPROM to be written. When EEMWE is set (one), setting EEWE will write data to the EEPROM at the selected address. If EEMWE is zero, setting EEWE will have no effect. When EEMWE has been set (one) by software, hardware clears the bit to zero after four clock cycles. See the description of the EEWE bit for an EEPROM write procedure.

- **Bit 1 – EEWE: EEPROM Write Enable**

The EEPROM Write Enable Signal (EEWE) is the write strobe to the EEPROM. When address and data are correctly set up, the EEWE bit must be set to write the value into the EEPROM. The EEMWE bit must be set when the logical “1” is written to EEWE, otherwise no EEPROM write takes place. The following procedure should be followed when writing the EEPROM (the order of steps 2 and 3 is not essential):

1. Wait until EEWE becomes zero.
2. Write new EEPROM address to EEAR (optional).
3. Write new EEPROM data to EEDR (optional).
4. Write a logical “1” to the EEMWE bit in EECR (to be able to write a logical “1” to the EEWE bit, the EEWE bit must be written to zero in the same cycle).
5. Within four clock cycles after setting EEMWE, write a logical “1” to EEWE.

**Caution:** An interrupt between step 4 and step 5 will make the write cycle fail, since the EEPROM Master Write Enable will time-out. If an interrupt routine accessing the EEPROM is interrupting another EEPROM access, the EEAR or EEDR Register will be modified, causing the interrupted EEPROM access to fail. It is recommended to have the Global Interrupt Flag cleared during the four last steps to avoid these problems.

When the write access time has elapsed, the EEWE bit is cleared (zero) by hardware. The user software can poll this bit and wait for a zero before writing the next byte. When EEWE has been set, the CPU is halted for two cycles before the next instruction is executed.

- **Bit 0 – EERE: EEPROM Read Enable**

The EEPROM Read Enable signal (EERE) is the read strobe to the EEPROM. When the correct address is set up in the EEAR Register, the EERE bit must be set. When the EERE bit is cleared (zero) by hardware, requested data is found in the EEDR Register. The EEPROM read access takes one instruction and there is no need to poll the EERE

bit. When EERE has been set, the CPU is halted for four cycles before the next instruction is executed.

The user should poll the EEWE bit before starting the read operation. If a write operation is in progress when new data or address is written to the EEPROM I/O Registers, the write operation will be interrupted and the result is undefined.

An RC Oscillator is used to time EEPROM write access. The table below lists the typical programming time listed for EEPROM access from CPU.

**Table 21.** EEPROM Access Time from CPU“See “Typical Characteristics” on page 138 to find RC Oscillator frequency.” on page 62<sup>(1)</sup>

Symbol	No. of RC Oscillator Cycles	Min Programming Time	Max Programming Time
EEPROM write (from CPU)	2048	2.0 ms	3.4 ms

Note: 1. See “Typical Characteristics” on page 138 to find RC Oscillator frequency.

## Prevent EEPROM Corruption

During periods of low  $V_{CC}$ , the EEPROM data can be corrupted because the supply voltage is too low for the CPU and the EEPROM to operate properly. These issues are the same as for board-level systems using the EEPROM, and the same design solutions should be applied.

An EEPROM data corruption can be caused by two situations when the voltage is too low. First, a regular write sequence to the EEPROM requires a minimum voltage to operate correctly. Secondly, the CPU itself can execute instructions incorrectly if the supply voltage for executing instructions is too low.

EEPROM data corruption can easily be avoided by following these design recommendations (one is sufficient):

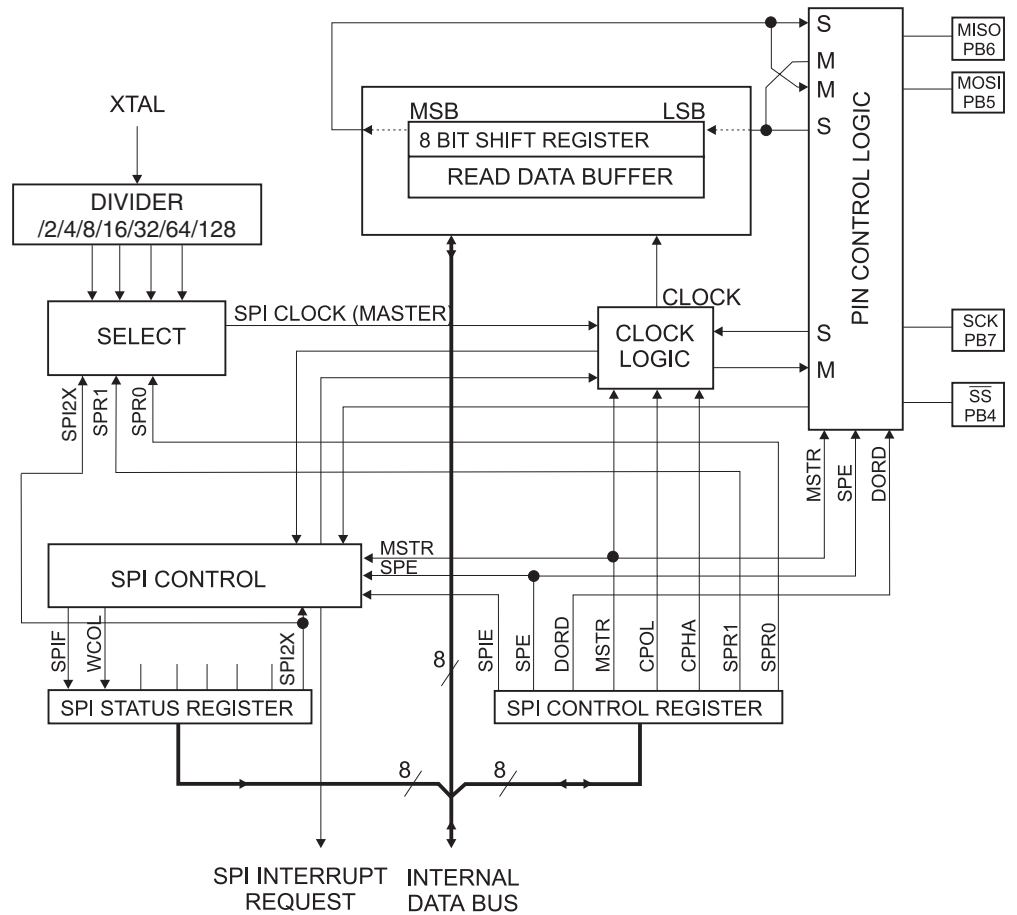
1. Keep the AVR RESET active (low) during periods of insufficient power supply voltage. An external low  $V_{CC}$  Reset Protection circuit can be applied.
2. Keep the AVR core in Power-down Sleep mode during periods of low  $V_{CC}$ . This will prevent the CPU from attempting to decode and execute instructions, effectively protecting the EEPROM Registers from unintentional writes.
3. Store constants in Flash memory if the ability to change memory contents from software is not required. Flash memory cannot be updated by the CPU unless the boot loader software supports writing to the Flash and the Boot Lock bits are configured so that writing to the Flash memory from the CPU is allowed. See “Boot Loader Support” on page 110 for details.

## Serial Peripheral Interface – SPI

The Serial Peripheral Interface (SPI) allows high-speed synchronous data transfer between the ATmega161 and peripheral devices or between several AVR devices. The ATmega161 SPI features include the following:

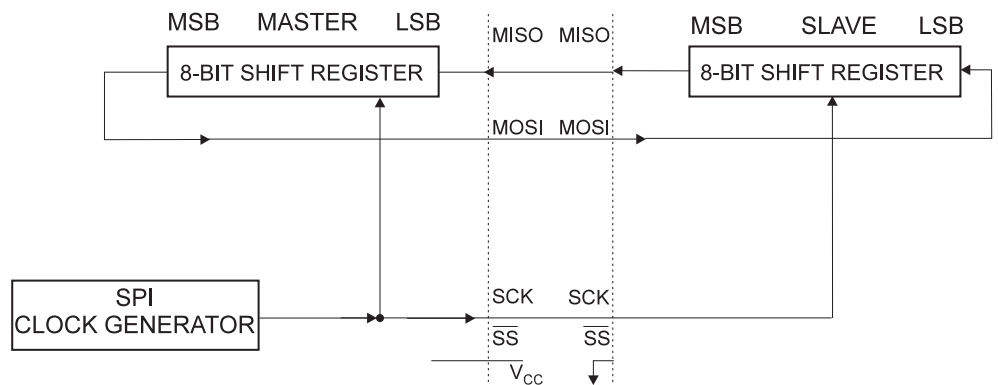
- Full-duplex, 3-wire Synchronous Data Transfer
- Master or Slave Operation
- LSB First or MSB First Data Transfer
- Seven Programmable Bit Rates
- End-of-Transmission Interrupt Flag
- Write Collision Flag Protection
- Wake-up from Idle Mode (Slave Mode Only)
- Double-speed (CK/2) Master SPI Mode

Figure 40. SPI Block Diagram



The interconnection between Master and Slave CPUs with SPI is shown in Figure 41. The PB7(SCK) pin is the Clock Output in the Master mode and is the clock input in the Slave mode. Writing to the SPI Data Register of the Master CPU starts the SPI clock generator, and the data written shifts out of the PB5(MOSI) pin and into the PB5(MOSI) pin of the Slave CPU. After shifting one byte, the SPI clock generator stops, setting the End-of-Transmission Flag (SPIF). If the SPI Interrupt Enable bit (SPIE) in the SPCR Register is set, an interrupt is requested. The Slave Select input, PB4( $\overline{SS}$ ), is set low to select an individual Slave SPI device. The two Shift Registers in the Master and the Slave can be considered as one distributed 16-bit circular Shift Register. This is shown in Figure 41. When data is shifted from the Master to the Slave, data is also shifted in the opposite direction, simultaneously. This means that during one shift cycle, data in the Master and the Slave are interchanged.

**Figure 41.** SPI Master-Slave Interconnection



The system is single-buffered in the transmit direction and double-buffered in the receive direction. This means that bytes to be transmitted cannot be written to the SPI Data Register before the entire shift cycle is completed. When receiving data, however, a received byte must be read from the SPI Data Register before the next byte has been completely shifted in. Otherwise, the first byte is lost.

When the SPI is enabled, the data direction of the MOSI, MISO, SCK and  $\overline{SS}$  pins is overridden according to Table 22.

**Table 22.** SPI Pin Overrides<sup>(1)</sup>

Pin	Direction, Master SPI	Direction, Slave SPI
MOSI	User Defined	Input
MISO	Input	User Defined
SCK	User Defined	Input
$\overline{SS}$	User Defined	Input

Note: 1. See "Alternate Functions of Port B" on page 92 for a detailed description of how to define the direction of the user defined SPI pins.

## SS Pin Functionality

When the SPI is configured as a Master (MSTR in SPCR is set), the user can determine the direction of the SS pin. If  $\overline{SS}$  is configured as an output, the pin is a general output pin, which does not affect the SPI system. If  $\overline{SS}$  is configured as an input, it must be held high to ensure Master SPI operation. If the  $\overline{SS}$  pin is driven low by peripheral circuitry when the SPI is configured as Master with the  $\overline{SS}$  pin defined as an input, the SPI system interprets this as another Master selecting the SPI as a Slave and starting to send data to it. To avoid bus contention, the SPI system takes the following actions:

1. The MSTR bit in SPCR is cleared and the SPI system becomes a Slave. As a result of the SPI becoming a Slave, the MOSI and SCK pins become inputs.
2. The SPIF Flag in SPSR is set, and if the SPI interrupt is enabled and the I-bit in SREG is set, the interrupt routine will be executed.

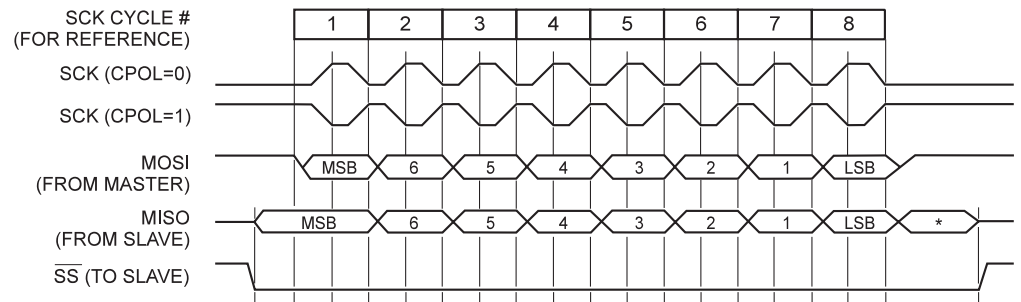
Thus, when interrupt-driven SPI transmission is used in Master mode, and there exists a possibility that  $\overline{SS}$  is driven low. The interrupt should always check that the MSTR bit is still set. Once the MSTR bit has been cleared by a Slave select, it must be set by the user to re-enable SPI Master mode.

When the SPI is configured as a Slave, the  $\overline{SS}$  pin is always input. When  $\overline{SS}$  is held low, the SPI is activated and MISO becomes an output if configured so by the user. All other pins are inputs. When  $\overline{SS}$  is driven high, all pins are inputs and the SPI is passive, which means that it will not receive incoming data. Note that the SPI logic will be reset once the  $\overline{SS}$  pin is brought high. If the  $\overline{SS}$  pin is brought high during a transmission, the SPI will stop sending and receiving immediately and both data received and data sent must be considered lost.

## Data Modes

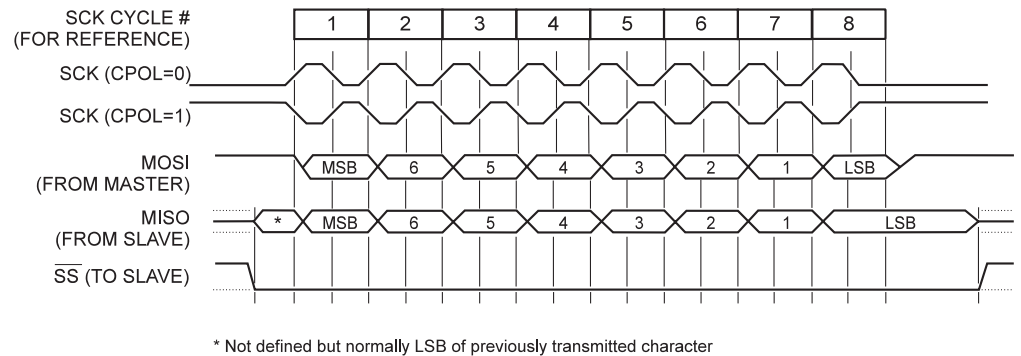
There are four combinations of SCK phase and polarity with respect to serial data, which are determined by control bits CPHA and CPOL. The SPI data transfer formats are shown in Figure 42 and Figure 43.

**Figure 42.** SPI Transfer Format with CPHA = 0 and DORD = 0



\* Not defined but normally MSB of character just received

**Figure 43. SPI Transfer Format with CPHA = 1 and DORD = 0**



### SPI Control Register – SPCR

Bit	7	6	5	4	3	2	1	0	
\$0D (\$2D)	<b>SPIE</b>	<b>SPE</b>	<b>DORD</b>	<b>MSTR</b>	<b>CPOL</b>	<b>CPHA</b>	<b>SPR1</b>	<b>SPR0</b>	<b>SPCR</b>
Read/Write	R/W	R/W	R/W	R/W	R/W	R/W	R/W	R/W	
Initial Value	0	0	0	0	0	0	0	0	

- **Bit 7 – SPIE: SPI Interrupt Enable**

This bit causes the SPI interrupt to be executed if SPIF bit in the SPSR Register is set and if the global interrupt enable bit in SREG is set.

- **Bit 6 – SPE: SPI Enable**

When the SPE bit is set (one), the SPI is enabled. This bit must be set to enable any SPI operations.

- **Bit 5 – DORD: Data Order**

When the DORD bit is set (one), the LSB of the data word is transmitted first.

When the DORD bit is cleared (zero), the MSB of the data word is transmitted first.

- **Bit 4 – MSTR: Master/Slave Select**

This bit selects Master SPI mode when set (one), and Slave SPI mode when cleared (zero). If  $\overline{SS}$  is configured as an input and is driven low while MSTR is set, MSTR will be cleared and SPIF in SPSR will become set. The user will then have to set MSTR to re-enable SPI Master mode.

- **Bit 3 – CPOL: Clock Polarity**

When this bit is set (one), SCK is high when idle. When CPOL is cleared (zero), SCK is low when idle. Refer to Figure 42 and Figure 43 for additional information.

- **Bit 2 – CPHA: Clock Phase**

Refer to Figure 42 or Figure 43 for the functionality of this bit.

- **Bits 1, 0 – SPR1, SPR0: SPI Clock Rate Select 1 and 0**

These two bits control the SCK rate of the device configured as a Master. SPR1 and SPR0 have no effect on the Slave. The relationship between SCK and the Oscillator Clock frequency ( $f_{cl}$ ) is shown in Table 23:

**Table 23.** Relationship between SCK and the Oscillator Frequency<sup>(1)</sup>

SPI2X	SPR1	SPR0	SCK Frequency
0	0	0	$f_{cl}/4$
0	0	1	$f_{cl}/16$
0	1	0	$f_{cl}/64$
0	1	1	$f_{cl}/128$
1	0	0	$f_{cl}/2$
1	0	1	$f_{cl}/8$
1	1	0	$f_{cl}/32$
1	1	1	$f_{cl}/64$

Note: 1. When the SPI is configured as Slave, the SPI is only guaranteed to work at  $f_{cl}/4$ .

## SPI Status Register – SPSR

Bit	7	6	5	4	3	2	1	0	
\$0E (\$2E)	<b>SPIF</b>	<b>WCOL</b>	–	–	–	–	–	<b>SPI2X</b>	SPSR
Read/Write	R	R	R	R	R	R	R	R/W	
Initial Value	0	0	0	0	0	0	0	0	

- **Bit 7 – SPIF: SPI Interrupt Flag**

When a serial transfer is complete, the SPIF bit is set (one) and an interrupt is generated if SPIE in SPCR is set (one) and global interrupts are enabled. If  $\overline{SS}$  is an input and is driven low when the SPI is in Master mode, this will also set the SPIF Flag. SPIF is cleared by hardware when executing the corresponding Interrupt Handling Vector. Alternatively, the SPIF bit is cleared by first reading the SPI Status Register with SPIF set (one), then by accessing the SPI Data Register (SPDR).

- **Bit 6 – WCOL: Write Collision Flag**

The WCOL bit is set if the SPI Data Register (SPDR) is written during a data transfer. The WCOL bit (and the SPIF bit) are cleared (zero) by first reading the SPI Status Register with WCOL set (one), and then by accessing the SPI Data Register.

- **Bits 5..1 – Res: Reserved Bits**

These bits are reserved bits in the ATmega161 and will always read as zero.

- **Bit 0 – SPI2X: Double SPI Speed Bit**

When this bit is set (one), the SPI speed (SCK frequency) will be doubled when the SPI is in Master mode (see Table 23). This means that the maximum SCK period will be two CPU clock periods. When the SPI is configured as Slave, the SPI is only guaranteed to work at  $f_{cl}/4$ .

The SPI interface on the ATmega161 is also used for Program memory and EEPROM downloading or uploading. See page 125 for serial programming and verification.

## SPI Data Register – SPDR

Bit	7	6	5	4	3	2	1	0	
\$0F (\$2F)	<b>MSB</b>							<b>LSB</b>	<b>SPDR</b>
Read/Write	R/W	R/W	R/W	R/W	R/W	R/W	R/W	R/W	
Initial Value	x	x	x	x	x	x	x	x	Undefined

The SPI Data Register is a read/write register used for data transfer between the Register File and the SPI Shift Register. Writing to the register initiates data transmission. Reading the register causes the Shift Register Receive buffer to be read.

## UARTs

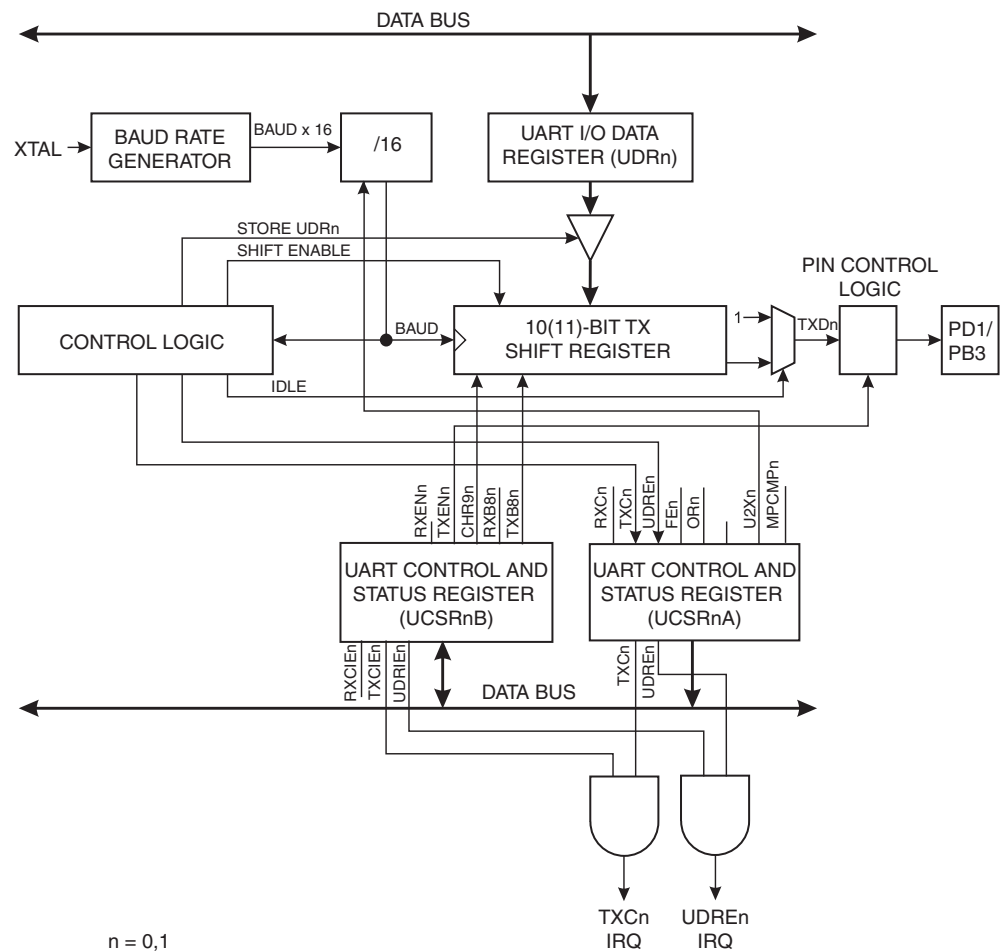
The ATmega161 features two full-duplex (separate Receive and Transmit Registers) Universal Asynchronous Receiver and Transmitters (UARTs). The main features are:

- **Baud Rate Generator Generates any Baud Rate**
- **High Baud Rates at low XTAL Frequencies**
- **8 or 9 Bits Data**
- **Noise Filtering**
- **Overrun Detection**
- **Framing Error Detection**
- **False Start Bit Detection**
- **Three Separate Interrupts on TX Complete, TX Data Register Empty, and RX Complete**
- **Multi-processor Communication Mode**
- **Double-speed UART Mode**

## Data Transmission

A block schematic of the UART Transmitter is shown in Figure 44. The two UARTs are identical and the functionality is described in general for the two UARTs.

**Figure 44.** UART Transmitter



Data transmission is initiated by writing the data to be transmitted to the UART I/O Data Register, UDRn. Data is transferred from UDRn to the Transmit Shift Register when:

- A new character has been written to UDRn after the stop bit from the previous character has been shifted out. The Shift Register is loaded immediately.

- A new character has been written to UDRn before the stop bit from the previous character has been shifted out. The Shift Register is loaded when the stop bit of the character currently being transmitted has been shifted out.

If the 10(11)-bit Transmit Shift Register is empty, data is transferred from UDRn to the Shift Register. At this time the UDREn (UART Data Register Empty) bit in the UART Control and Status Register, UCSRnA, is set. When this bit is set (one), the UART is ready to receive the next character. At the same time as the data is transferred from UDRn to the 10(11)-bit Shift Register, bit 0 of the Shift Register is cleared (start bit) and bit 9 or 10 is set (stop bit). If 9-bit data word is selected (the CHR9n bit in the UART Control and Status Register, UCSRnB, is set), the TXB8 bit in UCSRnB is transferred to bit 9 in the Transmit Shift Register.

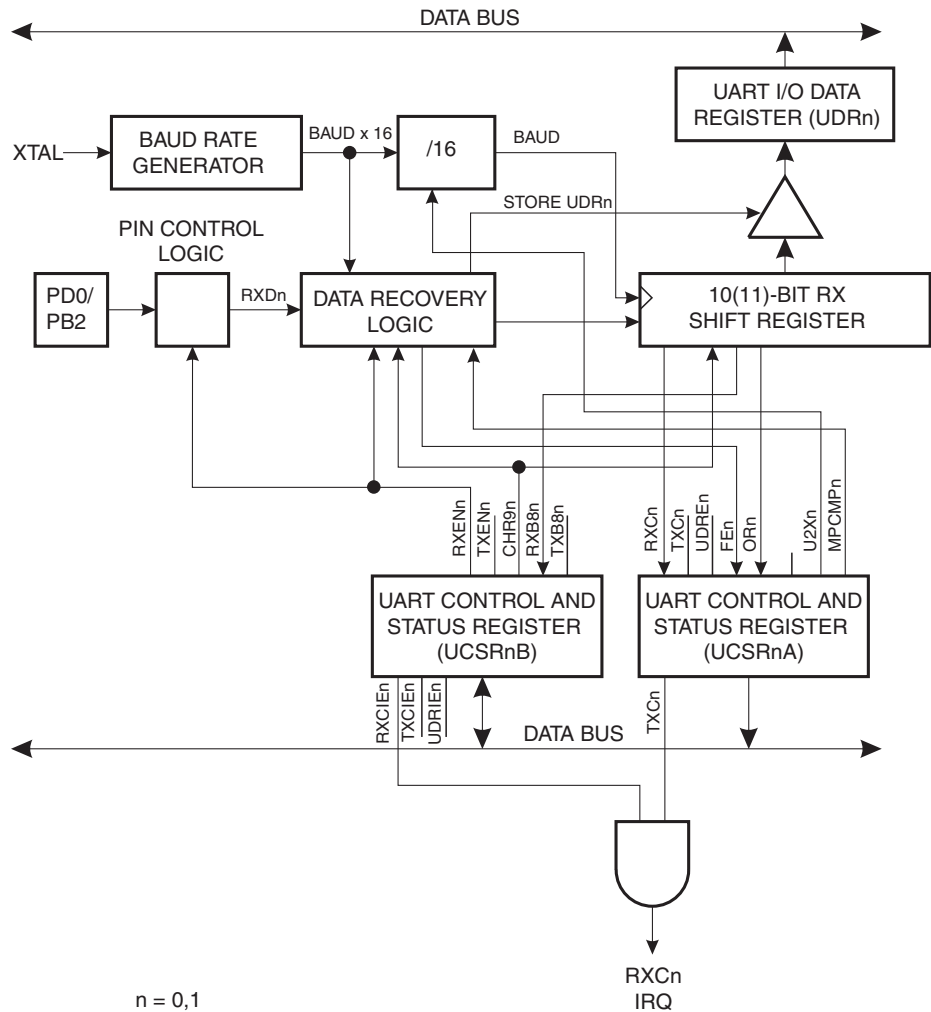
On the baud rate clock following the transfer operation to the Shift Register, the start bit is shifted out on the TXDn pin. Then follows the data, LSB first. When the stop bit has been shifted out, the Shift Register is loaded if any new data has been written to the UDRn during the transmission. During loading, UDREn is set. If there is no new data in the UDRn Register to send when the stop bit is shifted out, the UDREn Flag will remain set until UDRn is written again. When no new data has been written and the stop bit has been present on TXDn for one bit length, the TX Complete Flag (TXCn) in UCSRnA is set.

The TXENn bit in UCSRnB enables the UART Transmitter when set (one). When this bit is cleared (zero), the PD1 (UART0) or PB3 (UART1) pin can be used for general I/O. When TXENn is set, the UART Transmitter will be connected to PD1 (UART0) or PB3 (UART1), which is forced to be an output pin regardless of the setting of the DDD1 bit in DDRD (UART0) or DDB3 in DDRB (UART1). Note that PB3 (UART1) also is used as one of the input pins to the Analog Comparator. It is therefore not recommended to use UART1 if the Analog Comparator is also used in the application at the same time.

## Data Reception

Figure 45 shows a block diagram of the UART Receiver.

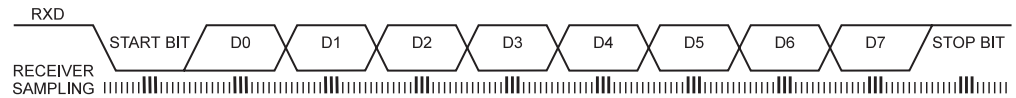
**Figure 45.** UART Receiver



The Receiver front-end logic samples the signal on the RXDn pin at a frequency 16 times the baud rate. While the line is idle, one single sample of logical “0” will be interpreted as the falling edge of a start bit, and the start bit detection sequence is initiated. Let sample 1 denote the first zero-sample. Following the 1-to-0 transition, the Receiver samples the RXDn pin at samples 8, 9 and 10. If two or more of these three samples are found to be logical “1”s, the start bit is rejected as a noise spike and the Receiver starts looking for the next 1-to-0 transition.

If, however, a valid start bit is detected, sampling of the data bits following the start bit is performed. These bits are also sampled at samples 8, 9 and 10. The logical value found in at least two of the three samples is taken as the bit value. All bits are shifted into the Transmitter Shift Register as they are sampled. Sampling of an incoming character is shown in Figure 46. Note that the description above is not valid when the UART transmission speed is doubled. See “Double-speed Transmission” on page 78 for a detailed description.

**Figure 46.** Sampling Received Data<sup>(1)</sup>



Note: 1. This figure is not valid when the UART speed is doubled. See “Double-speed Transmission” on page 78 for a detailed description.

When the stop bit enters the Receiver, the majority of the three samples must be one to accept the stop bit. If two or more samples are logical “0”s, the Framing Error (FEn) Flag in the UART Control and Status Register (UCSRnA) is set. Before reading the UDRn Register, the user should always check the FEn bit to detect framing errors.

Whether or not a valid stop bit is detected at the end of a character reception cycle, the data is transferred to UDRn and the RXCn Flag in UCSRnA is set. UDRn is in fact two physically separate registers, one for transmitted data and one for received data. When UDRn is read, the Receive Data Register is accessed, and when UDRn is written, the Transmit Data Register is accessed. If 9-bit data word is selected (the CHR9n bit in the UART Control and Status Register [UCSRnB] is set), the RXB8n bit in UCSRnB is loaded with bit 9 in the Transmit Shift Register when data is transferred to UDRn.

If, after having received a character, the UDRn Register has not been read since the last receive, the OverRun (ORn) Flag in UCSRnB is set. This means that the last data byte shifted into the Shift Register could not be transferred to UDRn and has been lost. The ORn bit is buffered and is updated when the valid data byte in UDRn is read. Thus, the user should always check the ORn bit after reading the UDRn Register in order to detect any overruns if the baud rate is high or CPU load is high.

When the RXEN bit in the UCSRnB Register is cleared (zero), the Receiver is disabled. This means that the PD0 pin can be used as a general I/O pin. When RXEN is set, the UART Receiver will be connected to PD0 (UART0) or PB2 (UART1), which is forced to be an input pin regardless of the setting of the DDD0 in DDRD (UART0) or DDB2 bit in DDRB (UART1). When PD0 (UART0) or PB2 (UART1) is forced to input by the UART, the PORTD0 (UART0) or PORTB2 (UART1) bit can still be used to control the pull-up resistor on the pin.

Note that PB2 (UART1) also is used as one of the input pins to the Analog Comparator. It is therefore not recommended to use UART1 if the Analog Comparator also is used in the application at the same time.

When the CHR9n bit in the UCSRnB Register is set, transmitted and received characters are nine bits long plus start and stop bits. The ninth data bit to be transmitted is the TXB8n bit in UCSRnB Register. This bit must be set to the wanted value before a transmission is initiated by writing to the UDRn Register. The ninth data bit received is the RXB8n bit in the UCSRnB Register.

## Multi-processor Communication Mode

The Multi-processor Communication mode enables several Slave MCUs to receive data from a master MCU. This is done by first decoding an address byte to find out which MCU has been addressed. If a particular Slave MCU has been addressed, it will receive the following data bytes as normal, while the other Slave MCUs will ignore the data bytes until another address byte is received.

For an MCU to act as a master MCU, it should enter 9-bit transmission mode (CHR9n in UCSRnB set). The ninth bit must be one to indicate that an address byte is being transmitted, and zero to indicate that a data byte is being transmitted.

For the Slave MCUs, the mechanism appears slightly different for 8-bit and 9-bit reception mode. In 8-bit reception mode (CHR9n in UCSRnB cleared), the stop bit is one for an address byte and zero for a data byte. In 9-bit reception mode (CHR9n in UCSRnB set), the ninth bit is one for an address byte and zero for a data byte, whereas the stop bit is always high.

The following procedure should be used to exchange data in Multi-processor Communication mode:

1. All Slave MCUs are in Multi-processor Communication mode (MPCMn in UCSRnA is set).
2. The master MCU sends an address byte and all Slaves receive and read this byte. In the Slave MCUs, the RXCn Flag in UCSRnA will be set as normal.
3. Each Slave MCU reads the UDRn Register and determines if it has been selected. If so, it clears the MPCMn bit in UCSRnA; otherwise, it waits for the next address byte.
4. For each received data byte, the receiving MCU will set the Receive Complete Flag (RXCn in UCSRnA). In 8-bit mode, the receiving MCU will also generate a framing error (FEn in UCSRnA set), since the stop bit is zero. The other Slave MCUs, which still have the MPCMn bit set, will ignore the data byte. In this case, the UDRn Register and the RXCn, FEn, or Flags will not be affected.
5. After the last byte has been transferred, the process repeats from step 2.

## UART Control

### UART0 I/O Data Register – UDR0

Bit	7	6	5	4	3	2	1	0	
\$0C (\$2C)	<b>MSB</b>							<b>LSB</b>	<b>UDR0</b>
Read/Write	R/W	R/W	R/W	R/W	R/W	R/W	R/W	R/W	
Initial Value	0	0	0	0	0	0	0	0	

### UART1 I/O Data Register – UDR1

Bit	7	6	5	4	3	2	1	0	
\$03 (\$23)	<b>MSB</b>							<b>LSB</b>	<b>UDR1</b>
Read/Write	R/W	R/W	R/W	R/W	R/W	R/W	R/W	R/W	
Initial Value	0	0	0	0	0	0	0	0	

The UDRn Register is actually two physically separate registers sharing the same I/O address. When writing to the register, the UART Transmit Data Register is written. When reading from UDRn, the UART Receive Data Register is read.

### UART0 Control and Status Registers – UCSR0A

Bit	7	6	5	4	3	2	1	0	
\$0B (\$2B)	<b>RXC0</b>	<b>TXC0</b>	<b>UDRE0</b>	<b>FE0</b>	<b>OR0</b>	–	<b>U2X0</b>	<b>MPCM0</b>	<b>UCSR0A</b>
Read/Write	R	R/W	R	R	R	R	R/W	R/W	
Initial Value	0	0	1	0	0	0	0	0	



## UART1 Control and Status Registers – UCSR1A

Bit	7	6	5	4	3	2	1	0	
\$02 (\$22)	<b>RXC1</b>	<b>TXC1</b>	<b>UDRE1</b>	<b>FE1</b>	<b>OR1</b>	–	<b>U2X1</b>	<b>MPCM1</b>	UCSR1A
Read/Write	R	R/W	R	R	R	R	R/W	R/W	
Initial Value	0	0	1	0	0	0	0	0	

### • Bit 7 – RXC0/RXC1: UART Receive Complete

This bit is set (one) when a received character is transferred from the Receiver Shift Register to UDRn. The bit is set regardless of any detected framing errors. When the RXCIEn bit in UCSRnB is set, the UART Receive Complete interrupt will be executed when RXCn is set (one). RXCn is cleared by reading UDRn. When interrupt-driven data reception is used, the UART Receive Complete Interrupt routine must read UDRn in order to clear RXCn; otherwise, a new interrupt will occur once the interrupt routine terminates.

### • Bit 6 – TXC0/TXC1: UART Transmit Complete

This bit is set (one) when the entire character (including the stop bit) in the Transmit Shift Register has been shifted out and no new data has been written to UDRn. This Flag is especially useful in half-duplex communications interfaces, where a transmitting application must enter Receive mode and free the communications bus immediately after completing the transmission.

When the TXCIEn bit in UCSRnB is set, setting of TXCn causes the UART Transmit Complete interrupt to be executed. TXCn is cleared by hardware when executing the corresponding Interrupt Handling Vector. Alternatively, the TXCn bit is cleared (zero) by writing a logical “1” to the bit.

### • Bit 5 – UDRE0/UDRE1: UART Data Register Empty

This bit is set (one) when a character written to UDRn is transferred to the Transmit Shift Register. Setting of this bit indicates that the Transmitter is ready to receive a new character for transmission.

When the UDRIEn bit in UCSRnB is set, the UART Transmit Complete interrupt will be executed as long as UDREn is set and the global interrupt enable bit in SREG is set. UDREn is cleared by writing UDRn. When interrupt-driven data transmittal is used, the UART Data Register Empty Interrupt routine must write UDRn in order to clear UDREn, otherwise a new interrupt will occur once the interrupt routine terminates.

UDREn is set (one) during reset to indicate that the Transmitter is ready.

### • Bit 4 – FE0/FE1: Framing Error

This bit is set if a Framing Error condition is detected, i.e., when the stop bit of an incoming character is zero.

The FEn bit is cleared when the stop bit of received data is one.

### • Bit 3 – OR0/OR1: OverRun

This bit is set if an Overrun condition is detected, i.e., when a character already present in the UDRn Register is not read before the next character has been shifted into the Receiver Shift Register. The ORn bit is buffered, which means that it will be set once the valid data still in UDRn is read.

The ORn bit is cleared (zero) when data is received and transferred to UDRn.

- **Bit 2 – Res: Reserved Bit**

This bit is reserved bit in the ATmega161 and will always read as zero.

- **Bit 1 – U2X0/U2X1: Double the UART Transmission Speed**

When this bit is set (one), the UART speed will be doubled. This means that a bit will be transmitted/received in 8 CPU clock periods instead of 16 CPU clock periods. For a detailed description, see “Double-speed Transmission” on page 78.

- **Bit 0 – MPCM0/MPCM1: Multi-processor Communication Mode**

This bit is used to enter Multi-processor Communication mode. The bit is set when the Slave MCU waits for an address byte to be received. When the MCU has been addressed, the MCU switches off the MPCMn bit and starts data reception.

For a detailed description, see “Multi-processor Communication mode”.

## UART0 Control and Status Registers – UCSR0B

Bit	7	6	5	4	3	2	1	0	
\$0A (\$2A)	<b>RXCIE0</b>	<b>TXCIE0</b>	<b>UDRIE0</b>	<b>RXEN0</b>	<b>TXEN0</b>	<b>CHR90</b>	<b>RXB80</b>	<b>TXB80</b>	<b>UCSR0B</b>
Read/Write	R/W	R/W	R/W	R/W	R/W	R/W	R	R/W	
Initial Value	0	0	0	0	0	0	1	0	

## UART1 Control and Status Registers – UCSR1B

Bit	7	6	5	4	3	2	1	0	
\$01 (\$21)	<b>RXCIE1</b>	<b>TXCIE1</b>	<b>UDRIE1</b>	<b>RXEN1</b>	<b>TXEN1</b>	<b>CHR91</b>	<b>RXB81</b>	<b>TXB81</b>	<b>UCSR1B</b>
Read/Write	R/W	R/W	R/W	R/W	R/W	R/W	R	R/W	
Initial Value	0	0	0	0	0	0	1	0	

- **Bit 7 – RXCIE0/RXCIE1: RX Complete Interrupt Enable**

When this bit is set (one), a setting of the RXCn bit in UCSRnA will cause the Receive Complete interrupt routine to be executed, provided that global interrupts are enabled.

- **Bit 6 – TXCIE0/TXCIE1: TX Complete Interrupt Enable**

When this bit is set (one), a setting of the TXCn bit in UCSRnA will cause the Transmit Complete interrupt routine to be executed, provided that global interrupts are enabled.

- **Bit 5 – UDRIE0/UDRIE1: UART Data Register Empty Interrupt Enable**

When this bit is set (one), a setting of the UDREn bit in UCSRnA will cause the UART Data Register Empty interrupt routine to be executed, provided that global interrupts are enabled.

- **Bit 4 – RXEN0/RXEN1: Receiver Enable**

This bit enables the UART Receiver when set (one). When the Receiver is disabled, the TXCn, ORn and FEn Status Flags cannot become set. If these flags are set, turning off RXEN does not cause them to be cleared.

- **Bit 3 – TXEN0/TXEN1: Transmitter Enable**

This bit enables the UART Transmitter when set (one). When disabling the Transmitter while transmitting a character, the Transmitter is not disabled before the character in the Shift Register plus any following character in UDRn has been completely transmitted.

- **Bit 2 – CHR90/CHR91: 9-bit Characters**

When this bit is set (one), transmitted and received characters are nine bits long, plus start and stop bits. The ninth bit is read and written by using the RXB8n and TXB8 bits in UCSRnB, respectively. The ninth data bit can be used as an extra stop bit or a parity bit.

- **Bit 1 – RXB80/RXB81: Receive Data Bit 8**

When CHR9n is set (one), RXB8n is the ninth data bit of the received character.

- **Bit 0 – TXB80/TXB81: Transmit Data Bit 8**

When CHR9n is set (one), TXB8n is the ninth data bit in the character to be transmitted.

## Baud Rate Generator

The baud rate generator is a frequency divider that generates baud rates according to the following equation:

$$\text{BAUD} = \frac{f_{\text{CK}}}{16(\text{UBR} + 1)}$$

- BAUD = Baud rate
- $f_{\text{CK}}$  = Crystal clock frequency
- UBR = Contents of the UBRRH and UBRR Registers (0 - 4095)
- Note that this equation is not valid when the UART transmission speed is doubled. See “Double-speed Transmission” for a detailed description.

For standard crystal frequencies, the most commonly used baud rates can be generated by using the UBR settings in Table 24. UBR values that yield an actual baud rate differing less than 2% from the target baud rate are boldface in the table. However, using baud rates that have more than 1% error is not recommended. High error ratings give less noise resistance.

**Table 24. UBR Settings at Various Crystal Frequencies**

Baud Rate	1 MHz	%Error	1.8432 MHz	%Error	2 MHz	%Error	2.4576 MHz	%Error
2400	UBR= 25	0.2	UBR= 47	0.0	UBR= 51	0.2	UBR= 63	0.0
4800	UBR= 12	0.2	UBR= 23	0.0	UBR= 25	0.2	UBR= 31	0.0
9600	UBR= 6	7.5	UBR= 11	0.0	UBR= 12	0.2	UBR= 15	0.0
14400	UBR= 3	7.8	UBR= 7	0.0	UBR= 8	3.7	UBR= 10	3.1
19200	UBR= 2	7.8	UBR= 5	0.0	UBR= 6	7.5	UBR= 7	0.0
28800	UBR= 1	7.8	UBR= 3	0.0	UBR= 3	7.8	UBR= 4	6.3
38400	UBR= 1	22.9	UBR= 2	0.0	UBR= 2	7.8	UBR= 3	0.0
57600	UBR= 0	7.8	UBR= 1	0.0	UBR= 1	7.8	UBR= 2	12.5
76800	UBR= 0	22.9	UBR= 1	33.3	UBR= 1	22.9	UBR= 1	0.0
115200	UBR= 0	84.3	UBR= 0	0.0	UBR= 0	7.8	UBR= 0	25.0

Baud Rate	3.2768 MHz	%Error	3.6864 MHz	%Error	4 MHz	%Error	4.608 MHz	%Error
2400	UBR= 84	0.4	UBR= 95	0.0	UBR= 103	0.2	UBR= 119	0.0
4800	UBR= 42	0.8	UBR= 47	0.0	UBR= 51	0.2	UBR= 59	0.0
9600	UBR= 20	1.6	UBR= 23	0.0	UBR= 25	0.2	UBR= 29	0.0
14400	UBR= 13	1.6	UBR= 15	0.0	UBR= 16	2.1	UBR= 19	0.0
19200	UBR= 10	3.1	UBR= 11	0.0	UBR= 12	0.2	UBR= 14	0.0
28800	UBR= 6	1.6	UBR= 7	0.0	UBR= 8	3.7	UBR= 9	0.0
38400	UBR= 4	6.3	UBR= 5	0.0	UBR= 6	7.5	UBR= 7	6.7
57600	UBR= 3	12.5	UBR= 3	0.0	UBR= 3	7.8	UBR= 4	0.0
76800	UBR= 2	12.5	UBR= 2	0.0	UBR= 2	7.8	UBR= 3	6.7
115200	UBR= 1	12.5	UBR= 1	0.0	UBR= 1	7.8	UBR= 2	20.0

Baud Rate	7.3728 MHz	%Error	8 MHz	%Error	9.216 MHz	%Error	11.059 MHz	%Error
2400	UBR= 191	0.0	UBR= 207	0.2	UBR= 239	0.0	UBR= 287	-
4800	UBR= 95	0.0	UBR= 103	0.2	UBR= 119	0.0	UBR= 143	0.0
9600	UBR= 47	0.0	UBR= 51	0.2	UBR= 59	0.0	UBR= 71	0.0
14400	UBR= 31	0.0	UBR= 34	0.8	UBR= 39	0.0	UBR= 47	0.0
19200	UBR= 23	0.0	UBR= 25	0.2	UBR= 29	0.0	UBR= 35	0.0
28800	UBR= 15	0.0	UBR= 16	2.1	UBR= 19	0.0	UBR= 23	0.0
38400	UBR= 11	0.0	UBR= 12	0.2	UBR= 14	0.0	UBR= 17	0.0
57600	UBR= 7	0.0	UBR= 8	3.7	UBR= 9	0.0	UBR= 11	0.0
76800	UBR= 5	0.0	UBR= 6	7.5	UBR= 7	6.7	UBR= 8	0.0
115200	UBR= 3	0.0	UBR= 3	7.8	UBR= 4	0.0	UBR= 5	0.0

### UART0 and UART1 High Byte Baud Rate Register UBRRHI

Bit	7	6	5	4	3	2	1	0	
\$20 (\$40)	MSB1			LSB1	MSB0			LSB0	UBRRHI
Read/Write	R/W	R/W	R/W	R/W	R/W	R/W	R/W	R/W	
Initial Value	0	0	0	0	0	0	0	0	

The UART Baud Register is a 12-bit register. The four most significant bits are located in a separate register, UBRRHI. Note that both UART0 and UART1 share this register. Bit 7 to bit 4 of UBRRHI contain the four most significant bits of the UART1 Baud Register. Bit 3 to bit 0 contain the four most significant bits of the UART0 Baud Register.

### UART0 Baud Rate Register Low Byte – UBRR0

Bit	7	6	5	4	3	2	1	0	
\$09 (\$29)	MSB							LSB	UBRR0
Read/Write	R/W	R/W	R/W	R/W	R/W	R/W	R/W	R/W	
Initial Value	0	0	0	0	0	0	0	0	

### UART1 Baud Rate Register Low Byte – UBRR1

Bit	7	6	5	4	3	2	1	0	
\$00 (\$20)	MSB							LSB	UBRR1
Read/Write	R/W	R/W	R/W	R/W	R/W	R/W	R/W	R/W	
Initial Value	0	0	0	0	0	0	0	0	

UBRRn stores the eight least significant bits of the UART Baud Rate Register.

### Double-speed Transmission

The ATmega161 provides a separate UART mode that allows the user to double the communication speed. By setting the U2X bit in UART Control and Status Register UCSRnA, the UART speed will be doubled. The data reception will differ slightly from Normal mode. Since the speed is doubled, the Receiver front-end logic samples the signals on RXDn pin at a frequency 8 times the baud rate. While the line is idle, one single sample of logical “0” will be interpreted as the falling edge of a start bit, and the start bit detection sequence is initiated. Let sample 1 denote the first zero-sample. Following the 1-to-0 transition, the Receiver samples the RXDn pin at samples 4, 5 and 6. If two or more of these three samples are found to be logical “1”s, the start bit is rejected as a noise spike and the Receiver starts looking for the next 1-to-0 transition.

If, however, a valid start bit is detected, sampling of the data bits following the start bit is performed. These bits are also sampled at samples 4, 5 and 6. The logical value found in at least two of the three samples is taken as the bit value. All bits are shifted into the Transmitter Shift Register as they are sampled. Sampling of an incoming character is shown in Figure 47.

**Figure 47.** Sampling Received Data when the Transmission Speed is Doubled



## The Baud Rate Generator in Double UART Speed Mode

Note that the baud rate equation is different from the equation on page 76 when the UART speed is doubled:

$$\text{BAUD} = \frac{f_{\text{CK}}}{8(\text{UBR} + 1)}$$

- BAUD = Baud rate
- $f_{\text{CK}}$  = Crystal Clock frequency
- UBR = Contents of the UBRRHI and UBRR Registers (0 - 4095)
- Note that this equation is only valid when the UART transmission speed is doubled.

For standard crystal frequencies, the most commonly used baud rates can be generated by using the UBR settings in Table 24. UBR values that yield an actual baud rate differing less than 1.5% from the target baud rate are boldface in the table. However, since the number of samples are reduced and the system clock might have some variance (this applies especially when using resonators), it is recommended that the baud rate error be less than 0.5%.

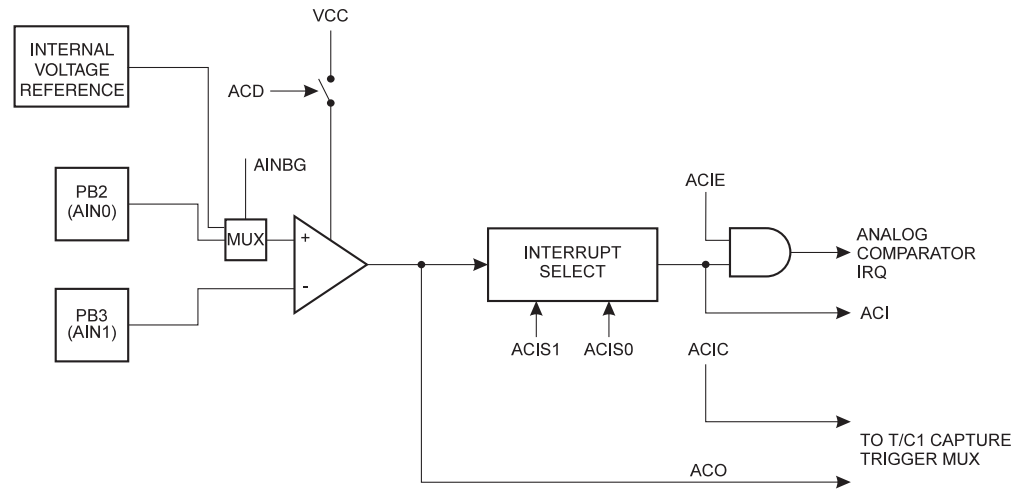
**Table 25.** UBR Settings at Various Crystal Frequencies in Double-speed Mode

Baud Rate	1.0000 MHz	% Error	1.8432 MHz	% Error	2.0000 MHz	% Error
<b>2400</b>	<b>UBR = 51</b>	0.2	<b>UBR = 95</b>	0.0	<b>UBR = 103</b>	0.2
<b>4800</b>	<b>UBR = 25</b>	0.2	<b>UBR = 47</b>	0.0	<b>UBR = 51</b>	0.2
<b>9600</b>	<b>UBR = 12</b>	0.2	<b>UBR = 23</b>	0.0	<b>UBR = 25</b>	0.2
<b>14400</b>	<b>UBR = 8</b>	3.7	<b>UBR = 15</b>	0.0	<b>UBR = 16</b>	2.1
<b>19200</b>	<b>UBR = 6</b>	7.5	<b>UBR = 11</b>	0.0	<b>UBR = 12</b>	0.2
<b>28800</b>	<b>UBR = 3</b>	7.8	<b>UBR = 7</b>	0.0	<b>UBR = 8</b>	3.7
<b>38400</b>	<b>UBR = 2</b>	7.8	<b>UBR = 5</b>	0.0	<b>UBR = 6</b>	7.5
<b>57600</b>	<b>UBR = 1</b>	7.8	<b>UBR = 3</b>	0.0	<b>UBR = 3</b>	7.8
<b>76800</b>	<b>UBR = 1</b>	22.9	<b>UBR = 2</b>	0.0	<b>UBR = 2</b>	7.8
<b>115200</b>	<b>UBR = 0</b>	84.3	<b>UBR = 1</b>	0.0	<b>UBR = 1</b>	7.8
<b>230400</b>	-	-	<b>UBR = 0</b>	0.0	<b>UBR = 0</b>	84.3
Baud Rate	3.2768 MHz	% Error	3.6864 MHz	% Error	4.0000 MHz	% Error
<b>2400</b>	<b>UBR = 170</b>	0.2	<b>UBR = 191</b>	0.0	<b>UBR = 207</b>	0.2
<b>4800</b>	<b>UBR = 84</b>	0.4	<b>UBR = 95</b>	0.0	<b>UBR = 103</b>	0.2
<b>9600</b>	<b>UBR = 42</b>	0.8	<b>UBR = 47</b>	0.0	<b>UBR = 51</b>	0.2
<b>14400</b>	<b>UBR = 27</b>	1.6	<b>UBR = 31</b>	0.0	<b>UBR = 34</b>	0.8
<b>19200</b>	<b>UBR = 20</b>	1.6	<b>UBR = 23</b>	0.0	<b>UBR = 25</b>	0.2
<b>28800</b>	<b>UBR = 13</b>	1.6	<b>UBR = 15</b>	0.0	<b>UBR = 16</b>	2.1
<b>38400</b>	<b>UBR = 10</b>	3.1	<b>UBR = 11</b>	0.0	<b>UBR = 12</b>	0.2
<b>57600</b>	<b>UBR = 6</b>	1.6	<b>UBR = 7</b>	0.0	<b>UBR = 8</b>	3.7
<b>76800</b>	<b>UBR = 4</b>	6.2	<b>UBR = 5</b>	0.0	<b>UBR = 6</b>	7.5
<b>115200</b>	<b>UBR = 3</b>	12.5	<b>UBR = 3</b>	0.0	<b>UBR = 3</b>	7.8
<b>230400</b>	<b>UBR = 1</b>	12.5	<b>UBR = 1</b>	0.0	<b>UBR = 1</b>	7.8
<b>460800</b>	<b>UBR = 0</b>	12.5	<b>UBR = 0</b>	0.0	<b>UBR = 0</b>	7.8
<b>912600</b>	-	-	-	-	<b>UBR = 0</b>	84.3
Baud Rate	7.3728 MHz	% Error	8.0000 MHz	% Error	9.2160 MHz	% Error
2400	<b>UBR = 383</b>	0.0	<b>UBR = 416</b>	0.1	<b>UBR = 479</b>	0.0
4800	<b>UBR = 191</b>	0.0	<b>UBR = 207</b>	0.2	<b>UBR = 239</b>	0.0
9600	<b>UBR = 95</b>	0.0	<b>UBR = 103</b>	0.2	<b>UBR = 119</b>	0.0
14400	<b>UBR = 63</b>	0.0	<b>UBR = 68</b>	0.6	<b>UBR = 79</b>	0.0
19200	<b>UBR = 47</b>	0.0	<b>UBR = 51</b>	0.2	<b>UBR = 59</b>	0.0
28800	<b>UBR = 31</b>	0.0	<b>UBR = 34</b>	0.8	<b>UBR = 39</b>	0.0
38400	<b>UBR = 23</b>	0.0	<b>UBR = 25</b>	0.2	<b>UBR = 29</b>	0.0
57600	<b>UBR = 15</b>	0.0	<b>UBR = 16</b>	2.1	<b>UBR = 19</b>	0.0
76800	<b>UBR = 11</b>	0.0	<b>UBR = 12</b>	0.2	<b>UBR = 14</b>	0.0
115200	<b>UBR = 7</b>	0.0	<b>UBR = 8</b>	3.7	<b>UBR = 9</b>	0.0
<b>230400</b>	<b>UBR = 3</b>	0.0	<b>UBR = 3</b>	7.8	<b>UBR = 4</b>	0.0
<b>460800</b>	<b>UBR = 1</b>	0.0	<b>UBR = 1</b>	7.8	<b>UBR = 2</b>	20.0
<b>912600</b>	<b>UBR = 0</b>	0.0	<b>UBR = 0</b>	7.8	<b>UBR = 0</b>	20.0

## Analog Comparator

The Analog Comparator compares the input values on the positive input PB2 (AIN0) and negative input PB3 (AIN1). When the voltage on the positive input PB2 (AIN0) is higher than the voltage on the negative input PB3 (AIN1), the Analog Comparator Output (ACO) is set (one). The comparator's output can be set to trigger the Timer/Counter1 Input Capture function. In addition, the comparator can trigger a separate interrupt, exclusive to the Analog Comparator. The user can select interrupt triggering on comparator output rise, fall or toggle. A block diagram of the comparator and its surrounding logic is shown in Figure 48.

**Figure 48.** Analog Comparator Block Diagram



## Analog Comparator Control and Status Register – ACSR

Bit	7	6	5	4	3	2	1	0	
\$08 (\$28)	<b>ACD</b>	<b>AINBG</b>	<b>ACO</b>	<b>ACI</b>	<b>ACIE</b>	<b>ACIC</b>	<b>ACIS1</b>	<b>ACIS0</b>	<b>ACSR</b>
Read/Write	R/W	R/W	R	R/W	R/W	R/W	R/W	R/W	
Initial Value	0	0	N/A	0	0	0	0	0	

- **Bit 7 – ACD: Analog Comparator Disable**

When this bit is set (one), the power to the Analog Comparator is switched off. This bit can be set at any time to turn off the Analog Comparator. This will reduce power consumption in active and Idle mode. When changing the ACD bit, the Analog Comparator Interrupt must be disabled by clearing the ACIE bit in ACSR. Otherwise, an interrupt can occur when the bit is changed.

- **Bit 6 – AINBG: Analog Comparator Bandgap Select**

When this bit is set, a fixed bandgap voltage of  $1.22 \pm 0.05V$  replaces the normal input to the positive input (AIN0) of the comparator. When this bit is cleared, the normal input pin PB2 is applied to the positive input of the comparator.

- **Bit 5 – ACO: Analog Comparator Output**

ACO is directly connected to the comparator output.

- **Bit 4 – ACI: Analog Comparator Interrupt Flag**

This bit is set (one) when a comparator output event triggers the interrupt mode defined by ACI1 and ACI0. The Analog Comparator Interrupt routine is executed if the ACIE bit is set (one) and the I-bit in SREG is set (one). ACI is cleared by hardware when executing the corresponding Interrupt Handling Vector. Alternatively, ACI is cleared by writing a logical “1” to the Flag.

- **Bit 3 – ACIE: Analog Comparator Interrupt Enable**

When the ACIE bit is set (one) and the I-bit in the Status Register is set (one), the Analog Comparator Interrupt is enabled. When cleared (zero), the interrupt is disabled.

- **Bit 2 – ACIC: Analog Comparator Input Capture Enable**

When set (one), this bit enables the Input Capture function in Timer/Counter1 to be triggered by the Analog Comparator. The comparator output is, in this case, directly connected to the Input Capture front-end logic, making the comparator utilize the noise canceler and edge select features of the Timer/Counter1 Input Capture Interrupt. When cleared (zero), no connection between the Analog Comparator and the Input Capture function is given. To make the comparator trigger the Timer/Counter1 Input Capture Interrupt, the TICIE1 bit in the Timer Interrupt Mask Register (TIMSK) must be set (one).

- **Bits 1, 0 – ACIS1, ACIS0: Analog Comparator Interrupt Mode Select**

These bits determine which comparator events trigger the Analog Comparator Interrupt. The different settings are shown in Table 26.

**Table 26.** ACIS1/ACIS0 Settings<sup>(1)</sup>

ACIS1	ACIS0	Interrupt Mode
0	0	Comparator Interrupt on Output Toggle
0	1	Reserved
1	0	Comparator Interrupt on Falling Output Edge
1	1	Comparator Interrupt on Rising Output Edge

Note: 1. When changing the ACIS1/ACIS0 bits, the Analog Comparator Interrupt must be disabled by clearing its Interrupt Enable bit in the ACSR Register. Otherwise, an interrupt can occur when the bits are changed.

**Caution:** Using the SBI or CBI instruction on bits other than ACI in this register will write a one back into ACI if it is read as set, thus clearing the Flag.

The Analog Comparator pins (PB2 and PB3) are also used as the TXD1 and RXD1 pins for UART1. Note that if the UART1 transceiver or Receiver is enabled, the UART1 will override the settings in the DDRB Register even if the Analog Comparator is enabled. Therefore, it is not recommended to use UART1 if the Analog Comparator is needed in the same application at the same time. See “UARTs” on page 69 for more details.

**Internal Voltage Reference**

ATmega161 features an internal voltage reference with a nominal voltage of 1.22V. This reference can be used as an input to the Analog Comparator.

**Voltage Reference Enable Signals and Start-up Time**

The voltage reference has a start-up time that may have an influence on the way it should be used. The maximum start-up time is TBD. To save power, the reference is on only when the AINBG bit in ACSR is set. Thus the user must always allow the reference to start up before the output from the Analog Comparator is used. The bandgap reference uses approximately 10  $\mu$ A, and to reduce the power consumption in Power-down mode, the user can turn off the reference when entering this mode.

## Interface to External Memory

With all the features the external memory interface provides, it is well suited to operate as an interface to memory devices such as external SRAM and Flash, and peripherals such as LCD display, A/D, D/A, etc. The control bits for the external memory interface are located in two registers, the MCU Control Register (MCUCR) and the Extended MCU Control Register (EMCUCR).

### MCU Control Register – MCUCR

Bit	7	6	5	4	3	2	1	0	
\$35 (\$55)	<b>SRE</b>	<b>SRW10</b>	<b>SE</b>	<b>SM1</b>	<b>ISC11</b>	<b>ISC10</b>	<b>ISC01</b>	<b>ISC00</b>	MCUCR
Read/Write	R/W	R/W	R/W	R/W	R/W	R/W	R/W	R/W	
Initial Value	0	0	0	0	0	0	0	0	

### Extended MCU Control Register – EMCUCR

Bit	7	6	5	4	3	2	1	0	
\$36 (\$56)	<b>SM0</b>	<b>SRL2</b>	<b>SRL1</b>	<b>SRL0</b>	<b>SRW01</b>	<b>SRW00</b>	<b>SRW11</b>	<b>ISC20</b>	EMCUCR
Read/Write	R/W	R/W	R/W	R/W	R/W	R/W	R/W	R/W	
Initial Value	0	0	0	0	0	0	0	0	

- **Bit 7 MCUCR – SRE: External SRAM Enable**

When the SRE bit is set (one), the external memory interface is enabled and the pin functions AD0 - 7 (Port A), A8 - 15 (Port C), ALE (Port E),  $\overline{WR}$  and  $\overline{RD}$  (Port D) are activated as the alternate pin functions. The SRE bit overrides any pin direction settings in the respective Data Direction Registers. See Figure 50 through Figure 53 for a description of the external memory pin functions. When the SRE bit is cleared (zero), the external Data memory interface is disabled and the normal pin and data direction settings are used.

- **Bits 6..4 EMCUCR – SRL2, SRL1, SRL0: Wait State Page Limit**

It is possible to configure different wait states for different external memory addresses. The external memory address space can be divided into two pages with different wait state bits. The SRL2, SRL1 and SRL0 bits select the split of the pages (see Table 28 and Figure 49). As defaults, the SRL2, SRL1 and SRL0 bits are set to zero and the entire external memory address space is treated as one page. When the entire SRAM address space is configured as one page, the wait states are configured by the SRW11 and SRW10 bits.

- **Bit 1 EMCUCR and Bit 6 MCUCR – SRW11, SRW10: Wait State Select Bits for Upper Page**

The SRW11 and SRW10 bits control the number of wait states for the upper page of the external memory address space (see Table 27). Note that if the SRL2, SRL1, and SRL0 bits are set to zero, the SRW11 and SRW10 bit settings will define the wait state of the entire SRAM address space.

- **Bits 3..2 EMCUCR – SRW01, SRW00: Wait State Select Bits for Lower Page**

The SRW01 and SRW00 bits control the number of wait states for the lower page of the external memory address space (see Table 27).

**Table 27.** Wait States<sup>(1)</sup>

SRWn1	SRWn0	Wait States
0	0	No wait states
0	1	Wait one cycle during read/write strobe
1	0	Wait two cycles during read/write strobe
1	1	Wait two cycles during read/write and wait one cycle before driving out new address

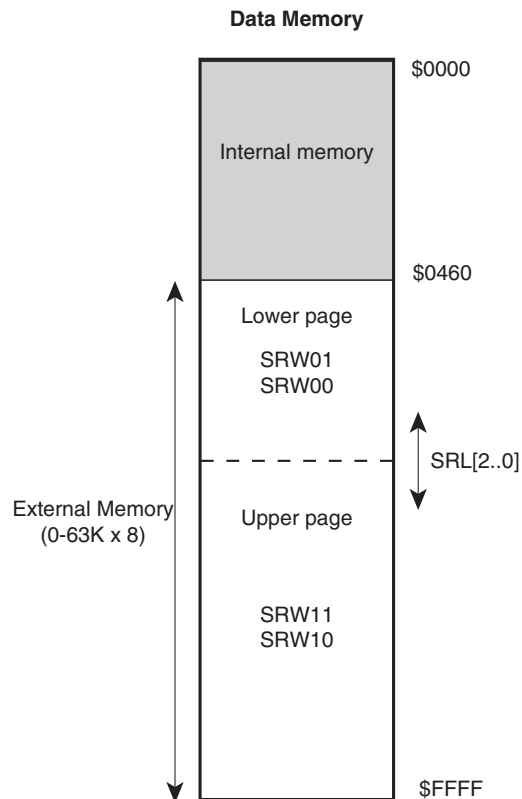
Note: 1. n = 0 or 1 (lower/upper page)

For further details of the timing and wait states of the external memory interface, see Figure 50 through Figure 53 for how the setting of the SRW bits affects the timing.

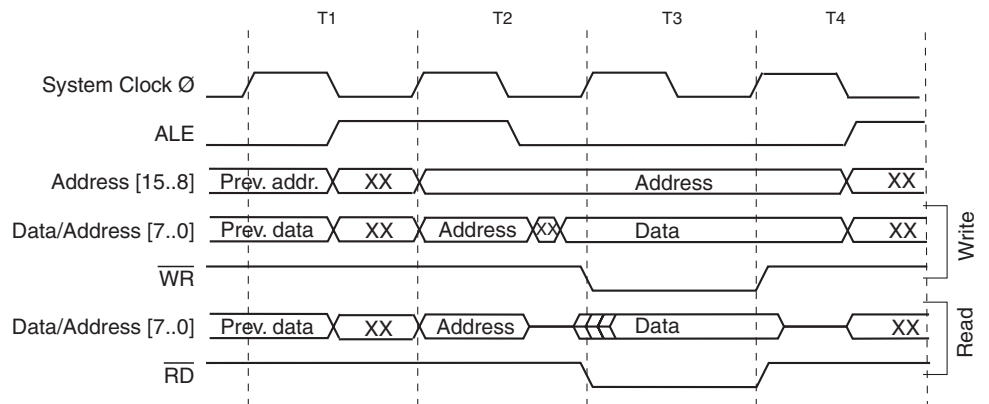
**Table 28.** Page Limits with Different Settings of SRL2..0

SRL2	SRL1	SRL0	Page Limits
0	0	0	Lower page = N/A Upper page = \$0460-\$FFFF
0	0	1	Lower page = \$0460-\$1FFF Upper page = \$2000-\$FFFF
0	1	0	Lower page = \$0460-\$4FFF Upper page = \$4000-\$FFFF
0	1	1	Lower page = \$0460-\$5FFF Upper page = \$6000-\$FFFF
1	0	0	Lower page = \$0460-\$7FFF Upper page = \$8000-\$FFFF
1	0	1	Lower page = \$0460-\$9FFF Upper page = \$A000-\$FFFF
1	1	0	Lower page = \$0460-\$BFFF Upper page = \$C000-\$FFFF
1	1	1	Lower page = \$0460-\$DFFF Upper page = \$E000-\$FFFF

**Figure 49.** External Memory with Page Select

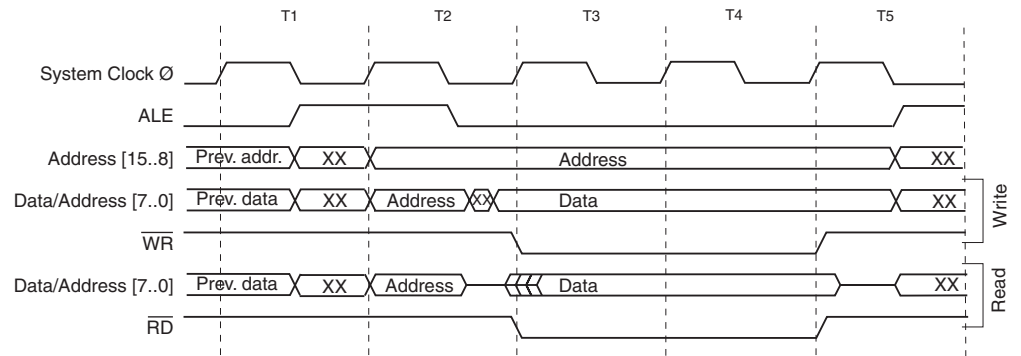


**Figure 50.** External Data Memory Cycles without Wait State (SRWn1 = 0 and SRWn0 = 0)<sup>(1)</sup>



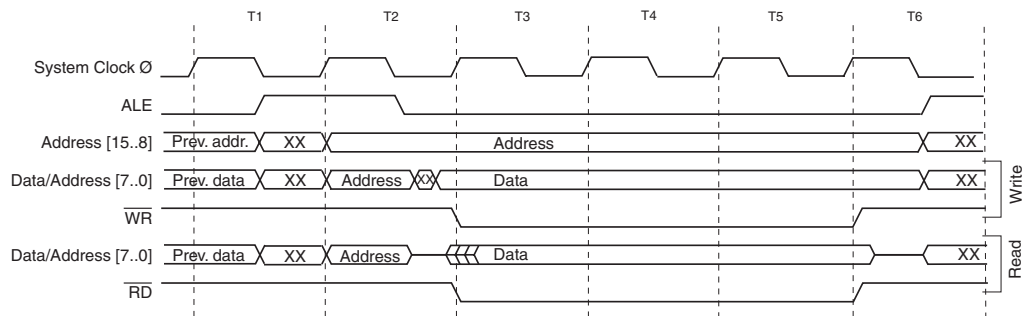
Note: 1. SRWn1 = SRW11 (upper page) or SRW01 (lower page), SRWn0 = SRW10 (upper page) or SRW00 (lower page).  
The ALE pulse in period T4 is only present if the next instruction accesses the RAM (internal or external). The Data and Address will only change in T4 if ALE is present (the next instruction accesses the RAM).

**Figure 51.** External Data Memory Cycles with  $SRWn1 = 0$  and  $SRWn0 = 1^{(1)}$



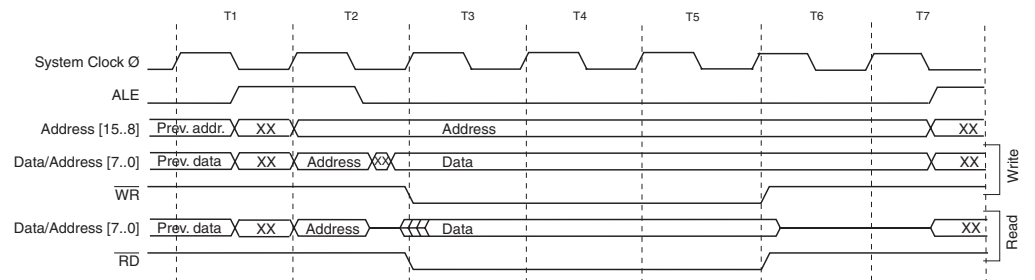
Note: 1.  $SRWn1 = SRW11$  (upper page) or  $SRW01$  (lower page),  $SRWn0 = SRW10$  (upper page) or  $SRW00$  (lower page). The ALE pulse in period T5 is only present if the next instruction accesses the RAM (internal or external). The Data and Address will only change in T5 if ALE is present (the next instruction accesses the RAM).

**Figure 52.** External Data Memory Cycles with  $SRWn1 = 1$  and  $SRWn0 = 0^{(1)}$



Note: 1.  $SRWn1 = SRW11$  (upper page) or  $SRW01$  (lower page),  $SRWn0 = SRW10$  (upper page) or  $SRW00$  (lower page). The ALE pulse in period T6 is only present if the next instruction accesses the RAM (internal or external). The Data and Address will only change in T6 if ALE is present (the next instruction accesses the RAM).

**Figure 53.** External Data Memory Cycles with  $SRWn1 = 1$  and  $SRWn0 = 1^{(1)}$



Note: 1.  $SRWn1 = SRW11$  (upper page) or  $SRW01$  (lower page),  $SRWn0 = SRW10$  (upper page) or  $SRW00$  (lower page). The ALE pulse in period T7 is only present if the next instruction accesses the RAM (internal or external). The Data and Address will only change in T7 if ALE is present (the next instruction accesses the RAM).

## Using the External Memory Interface

The interface consists of:

Port A: multiplexed low-order address bus and data bus

Port C: high-order address bus

The ALE pin: address latch enable

The  $\overline{RD}$  and  $\overline{WR}$  pin: read and write strobes

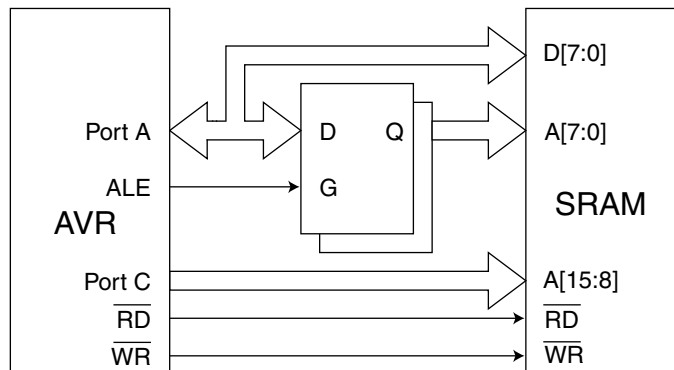
The external memory interface is enabled by setting the external SRAM enable bit (SRE) of the MCU Control Register (MCUCR) and will override the setting of the Data Direction Registers DDRA, DDRD and DDRE. When the SRE bit is cleared (zero), the external memory interface is disabled and the normal pin and data direction settings are used. When SRE is low, the address space above the internal SRAM boundary is not mapped into the internal SRAM, as in AVR parts do not have an external memory interface.

When ALE goes from high to low, there is a valid address on Port A. ALE is low during a data transfer.  $\overline{RD}$  and  $\overline{WR}$  are active when accessing the external memory only.

When the external memory interface is enabled, the ALE signal may have short pulses when accessing the internal RAM, but the ALE signal is stable when accessing the external memory.

Figure 54 sketches how to connect an external SRAM to the AVR using eight latches that are transparent when G is high.

**Figure 54.** External SRAM Connected to the AVR



For details on the timing for the SRAM interface, please see Figure 83 through Figure 86 and Table 51 through Table 58.

## I/O Ports

All AVR ports have true read-modify-write functionality when used as general digital I/O ports. This means that the direction of one port pin can be changed without unintentionally changing the direction of any other pin with the SBI and CBI instructions. The same applies for changing drive value (if configured as output) or enabling/disabling of pull-up resistors (if configured as input).

## Port A

Port A is an 8-bit bi-directional I/O port.

Three I/O memory address locations are allocated for the Port A, one each for the Data Register – PORTA, \$1B(\$3B), Data Direction Register – DDRA, \$1A(\$3A) and the Port A Input Pins – PINA, \$19(\$39). The Port A Input Pins address is read-only, while the Data Register and the Data Direction Register are read/write.

All port pins have individually selectable pull-up resistors. The Port A output buffers can sink 20 mA and thus drive LED displays directly. When pins PA0 to PA7 are used as inputs and are externally pulled low, they will source current if the internal pull-up resistors are activated.

The Port A pins have alternate functions related to the optional external memory interface. Port A can be configured to be the multiplexed low-order address/data bus during accesses to the external Data memory. In this mode, Port A has internal pull-up resistors.

When Port A is set to the alternate function by the SRE (External SRAM Enable) bit in the MCUCR (MCU Control Register), the alternate settings override the Data Direction Register.

### Port A Data Register – PORTA

Bit	7	6	5	4	3	2	1	0	
\$1B (\$3B)	<b>PORTA7</b>	<b>PORTA6</b>	<b>PORTA5</b>	<b>PORTA4</b>	<b>PORTA3</b>	<b>PORTA2</b>	<b>PORTA1</b>	<b>PORTA0</b>	PORTA
Read/Write	R/W	R/W	R/W	R/W	R/W	R/W	R/W	R/W	
Initial Value	0	0	0	0	0	0	0	0	

### Port A Data Direction Register – DDRA

Bit	7	6	5	4	3	2	1	0	
\$1A (\$3A)	<b>DDA7</b>	<b>DDA6</b>	<b>DDA5</b>	<b>DDA4</b>	<b>DDA3</b>	<b>DDA2</b>	<b>DDA1</b>	<b>DDA0</b>	DDRA
Read/Write	R/W	R/W	R/W	R/W	R/W	R/W	R/W	R/W	
Initial Value	0	0	0	0	0	0	0	0	

### Port A Input Pins Address – PINA

Bit	7	6	5	4	3	2	1	0	
\$19 (\$39)	<b>PINA7</b>	<b>PINA6</b>	<b>PINA5</b>	<b>PINA4</b>	<b>PINA3</b>	<b>PINA2</b>	<b>PINA1</b>	<b>PINA0</b>	PINA
Read/Write	R	R	R	R	R	R	R	R	
Initial Value	N/A	N/A	N/A	N/A	N/A	N/A	N/A	N/A	

The Port A Input Pins address (PINA) is not a register; this address enables access to the physical value on each Port A pin. When reading PORTA, the Port A Data Latch is read and when reading PINA, the logical values present on the pins are read.

### Port A as General Digital I/O

All eight pins in Port A have equal functionality when used as digital I/O pins.

PA<sub>n</sub>, general I/O pin: The DDAn bit in the DDRA Register selects the direction of this pin. If DDAn is set (one), PA<sub>n</sub> is configured as an output pin. If DDAn is cleared (zero), PA<sub>n</sub> is configured as an input pin. If PORTAn is set (one) when the pin is configured as an input pin, the MOS pull-up resistor is activated. To switch the pull-up resistor off, the PORTAn has to be cleared (zero) or the pin has to be configured as an output pin. The

Port A pins are tri-stated when a reset condition becomes active, even if the clock is not running.

**Table 29.** DDAn Effects on Port A Pins<sup>(1)</sup>

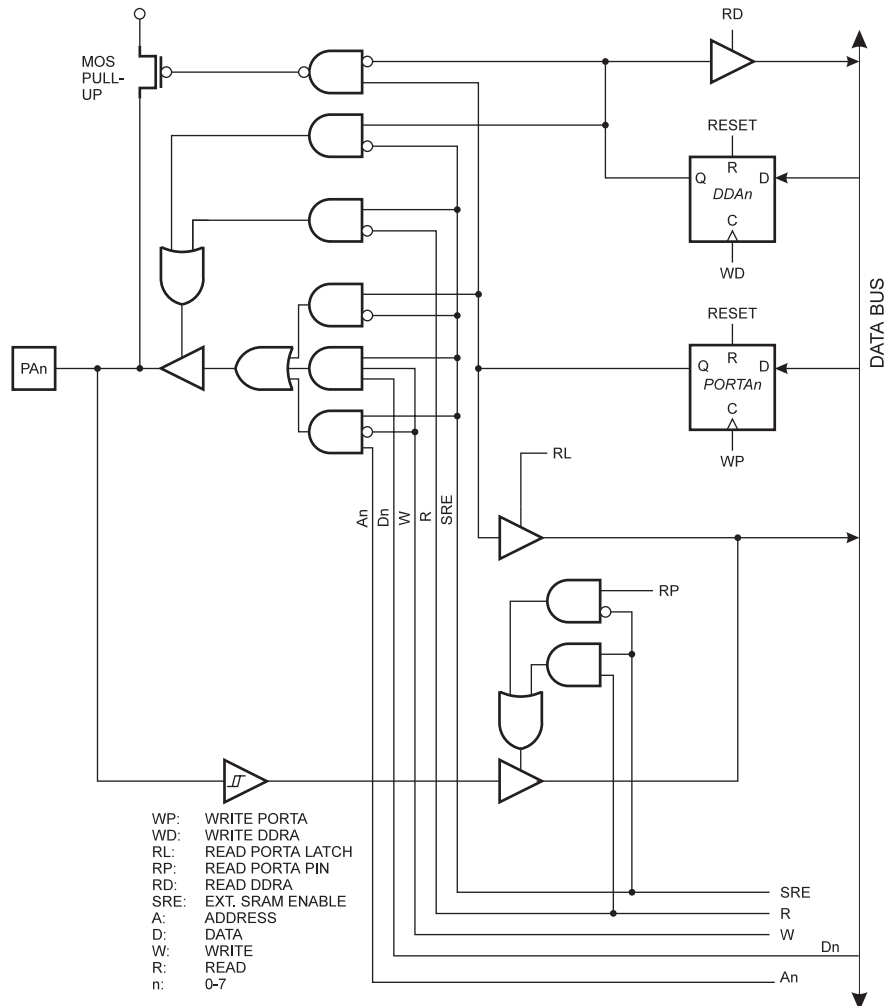
DDAn	PORTAn	I/O	Pull-up	Comment
0	0	Input	No	Tri-state (high-Z)
0	1	Input	Yes	PAn will source current if ext. pulled low.
1	0	Output	No	Push-pull Zero Output
1	1	Output	No	Push-pull One Output

Note: 1. n: 7,6...0, pin number

### Port A Schematics

Note that all port pins are synchronized. The synchronization latch is, however, not shown in the figure.

**Figure 55.** Port A Schematic Diagrams (Pins PA0 - PA7)



## Port B

Port B is an 8-bit bi-directional I/O port.

Three I/O memory address locations are allocated for the Port B, one each for the Data Register – PORTB, \$18(\$38), Data Direction Register – DDRB, \$17(\$37) and the Port B Input Pins – PINB, \$16(\$36). The Port B Input Pins address is read-only, while the Data Register and the Data Direction Register are read/write.

All port pins have individually selectable pull-up resistors. The Port B output buffers can sink 20 mA and thus drive LED displays directly. When pins PB0 to PB7 are used as inputs and are externally pulled low, they will source current if the internal pull-up resistors are activated.

The Port B pins with alternate functions are shown in Table 30.

**Table 30.** Port B Pin Alternate Functions<sup>(1)</sup>

Port Pin	Alternate Functions
PB0	OC0 (Timer/Counter0 Compare Match Output)/T0 (Timer/Counter0 External Counter Input)
PB1	OC2 (Timer/Counter2 Compare Match Output)/T1 (Timer/Counter1 External Counter Input)
PB2	RXD1 (UART1 Input Line)/AIN0 (Analog Comparator Positive Input)
PB3	TXD1 (UART1 Output Line)/AIN1 (Analog Comparator Negative Input)
PB4	$\overline{SS}$ (SPI Slave Select Input)
PB5	MOSI (SPI Bus Master Output/Slave Input)
PB6	MISO (SPI Bus Master Input/Slave Output)
PB7	SCK (SPI Bus Serial Clock)

Note: 1. When the pins are used for the alternate function, the DDRB and PORTB Registers have to be set according to the alternate function description.

### Port B Data Register – PORTB

Bit	7	6	5	4	3	2	1	0	
\$18 (\$38)	<b>PORTB7 PORTB6 PORTB5 PORTB4 PORTB3 PORTB2 PORTB1 PORTB0</b>								PORTB
Read/Write	R/W	R/W	R/W	R/W	R/W	R/W	R/W	R/W	
Initial Value	0	0	0	0	0	0	0	0	

### Port B Data Direction Register – DDRB

Bit	7	6	5	4	3	2	1	0	
\$17 (\$37)	<b>DDB7 DDB6 DDB5 DDB4 DDB3 DDB2 DDB1 DDB0</b>								DDR B
Read/Write	R/W	R/W	R/W	R/W	R/W	R/W	R/W	R/W	
Initial Value	0	0	0	0	0	0	0	0	

### Port B Input Pins Address – PINB

Bit	7	6	5	4	3	2	1	0	
\$16 (\$36)	<b>PINB7 PINB6 PINB5 PINB4 PINB3 PINB2 PINB1 PINB0</b>								PINB
Read/Write	R	R	R	R	R	R	R	R	
Initial Value	N/A	N/A	N/A	N/A	N/A	N/A	N/A	N/A	

The Port B Input Pins address (PINB) is not a register; this address enables access to the physical value on each Port B pin. When reading PORTB, the Port B Data Latch is read and when reading PINB, the logical values present on the pins are read.

## Port B as General Digital I/O

All eight pins in Port B have equal functionality when used as digital I/O pins.

PB<sub>n</sub>, general I/O pin: The DDB<sub>n</sub> bit in the DDRB Register selects the direction of this pin. If DDB<sub>n</sub> is set (one), PB<sub>n</sub> is configured as an output pin. If DDB<sub>n</sub> is cleared (zero), PB<sub>n</sub> is configured as an input pin. If PORTB<sub>n</sub> is set (one) when the pin is configured as an input pin, the MOS pull-up resistor is activated. To switch the pull-up resistor off, the PORTB<sub>n</sub> has to be cleared (zero) or the pin has to be configured as an output pin. The Port B pins are tri-stated when a reset condition becomes active, even if the clock is not running.

**Table 31.** DDB<sub>n</sub> Effects on Port B Pins<sup>(1)</sup>

DDB <sub>n</sub>	PORTB <sub>n</sub>	I/O	Pull-up	Comment
0	0	Input	No	Tri-state (high-Z)
0	1	Input	Yes	PB <sub>n</sub> will source current if ext. pulled low.
1	0	Output	No	Push-pull Zero Output
1	1	Output	No	Push-pull One Output

Note: 1. n: 7,6...0, pin number

## Alternate Functions of Port B

The alternate pin configuration is as follows:

- **SCK – Port B, Bit 7**

SCK: Master clock output, Slave clock input pin for SPI channel. When the SPI is enabled as a Slave, this pin is configured as an input regardless of the setting of DDB7. When the SPI is enabled as a master, the data direction of this pin is controlled by DDB7. When the pin is forced to be an input, the pull-up can still be controlled by the PORTB7 bit. See the description of the SPI port for further details.

- **MISO – Port B, Bit 6**

MISO: Master data input, Slave data output pin for SPI channel. When the SPI is enabled as a master, this pin is configured as an input regardless of the setting of DDB6. When the SPI is enabled as a Slave, the data direction of this pin is controlled by DDB6. When the pin is forced to be an input, the pull-up can still be controlled by the PORTB6 bit. See the description of the SPI port for further details.

- **MOSI – Port B, Bit 5**

MOSI: SPI Master data output, Slave data input for SPI channel. When the SPI is enabled as a Slave, this pin is configured as an input regardless of the setting of DDB5. When the SPI is enabled as a master, the data direction of this pin is controlled by DDB5. When the pin is forced to be an input, the pull-up can still be controlled by the PORTB5 bit. See the description of the SPI port for further details.

- **$\overline{SS}$  – Port B, Bit 4**

$\overline{SS}$ : Slave port select input. When the SPI is enabled as a Slave, this pin is configured as an input regardless of the setting of DDB5. As a Slave, the SPI is activated when this pin is driven low. When the SPI is enabled as a master, the data direction of this pin is controlled by DDB5. When the pin is forced to be an input, the pull-up can still be controlled by the PORTB5 bit. See the description of the SPI port for further details.

- **TXD1/AIN1 – Port B, Bit 3**

AIN1, Analog Comparator Negative Input. This pin also serves as the negative input of the On-chip Analog Comparator.

TXD1, Transmit Data (Data output pin for the UART1). When the UART1 Transmitter is enabled, this pin is configured as an output regardless of the value of DDRB3.

- **RXD1/AIN0 – Port B, Bit 2**

AIN0, Analog Comparator Positive Input. This pin also serves as the positive input of the On-chip Analog Comparator.

RXD1, Receive Data (Data input pin for the UART1). When the UART1 Receiver is enabled, this pin is configured as an input regardless of the value of DDRB2. When the UART1 forces this pin to be an input, a logical “1” in PORTB2 will turn on the internal pull-up.

- **OC2/T1 – Port B, Bit 1**

T1: Timer/Counter1 counter source. See “Timer/Counter1” on page 49 for further details.

OC2, Output compare match output: The PB1 pin can serve as an external output when the Timer/Counter2 compare matches. The PB1 pin has to be configured as an output (DDB1 set [one]) to serve this function. See “8-bit Timer/Counters T/C0 and T/C2” on page 40 for further details. The OC2 pin is also the output pin for the PWM mode timer function.

- **OC0/T0 – Port B, Bit 0**

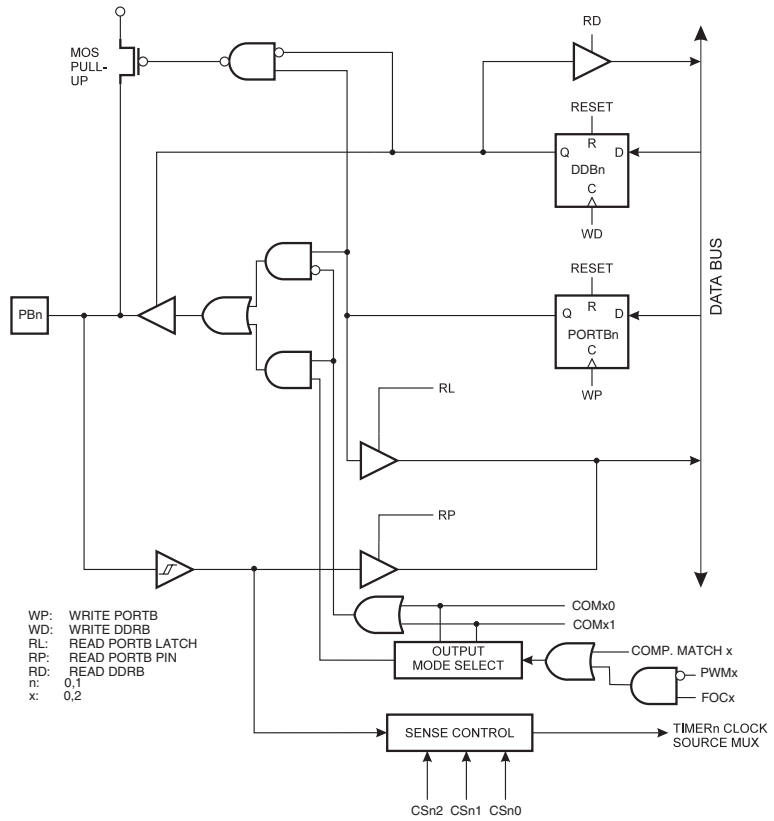
T0: Timer/Counter0 counter source. See “8-bit Timer/Counters T/C0 and T/C2” on page 40 further details.

OC0, Output compare match output: The PB0 pin can serve as an external output when the Timer/Counter0 compare matches. The PB0 pin has to be configured as an output (DDB0 set [one]) to serve this function. See “8-bit Timer/Counters T/C0 and T/C2” on page 40 for further details and how to enable the output. The OC0 pin is also the output pin for the PWM mode timer function.

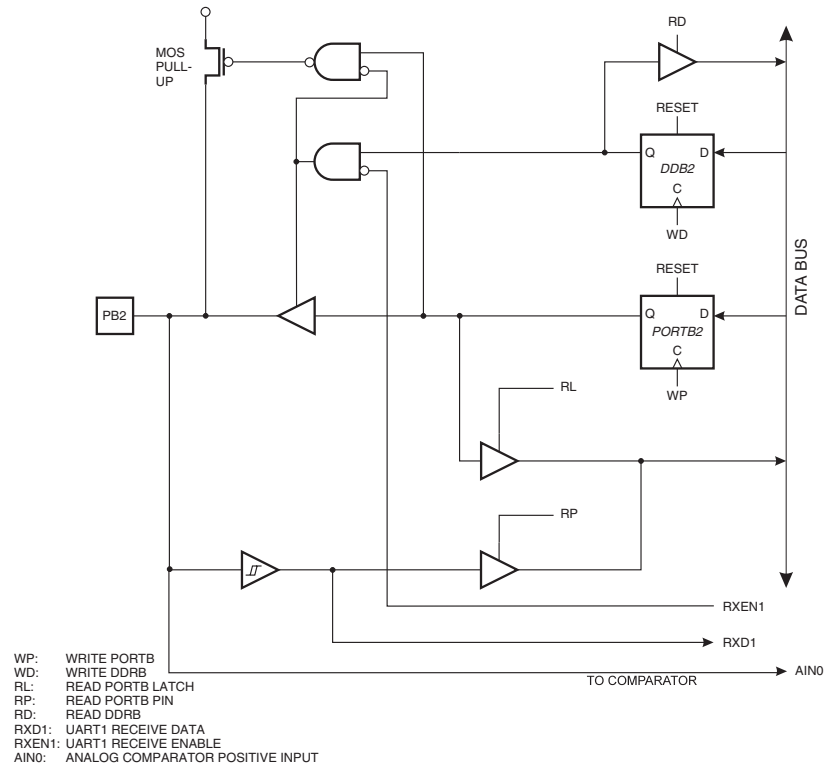
## Port B Schematics

Note that all port pins are synchronized. The synchronization latches are, however, not shown in the figures.

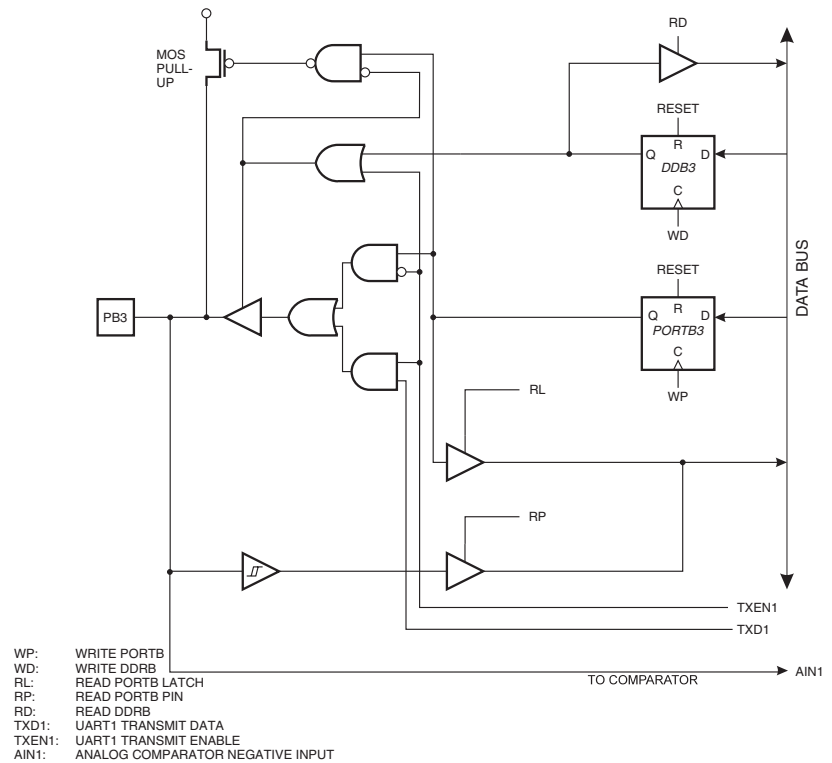
**Figure 56.** Port B Schematic Diagram (Pins PB0 and PB1)



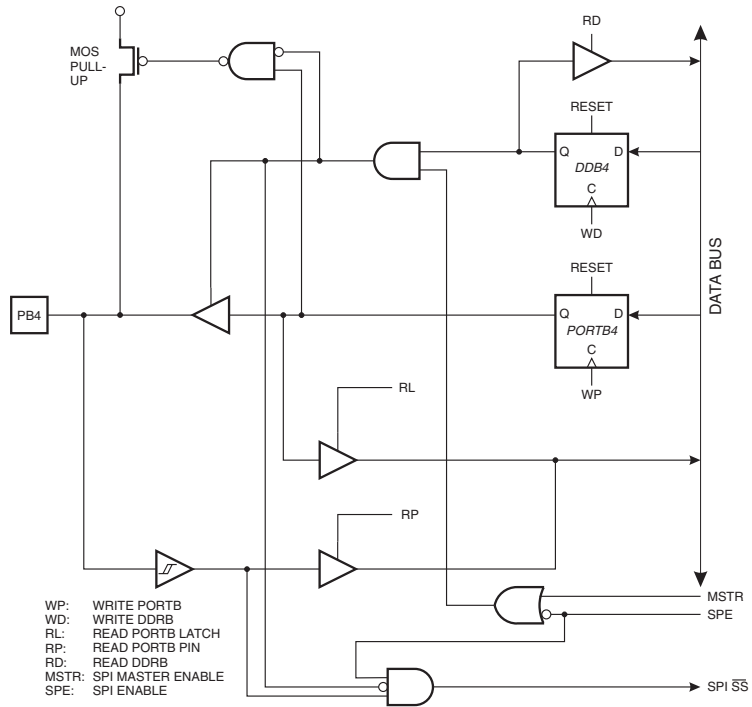
**Figure 57. Port B Schematic Diagram (Pin PB2)**



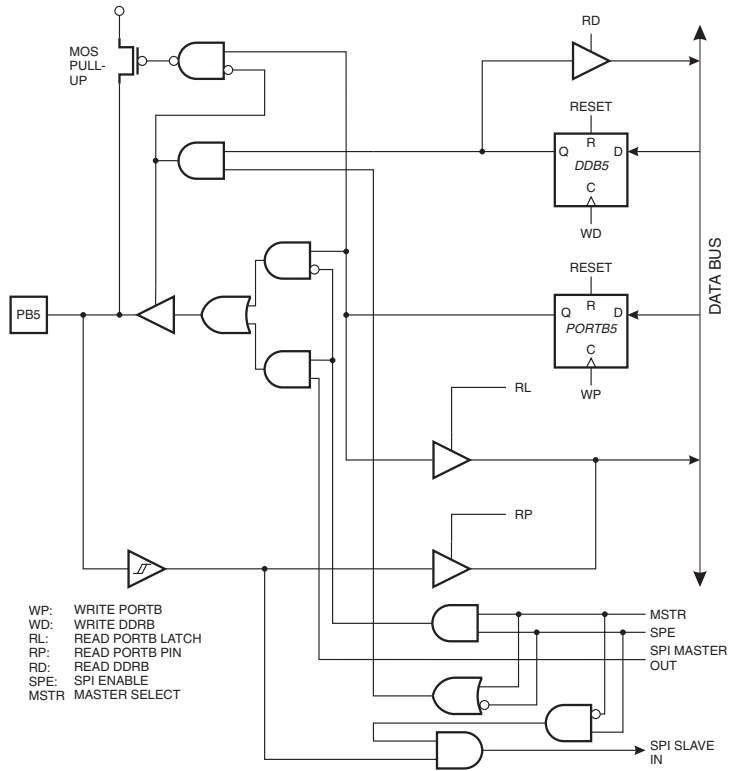
**Figure 58. Port B Schematic Diagram (Pin PB3)**



**Figure 59. Port B Schematic Diagram (Pin PB4)**



**Figure 60. Port B Schematic Diagram (Pin PB5)**





## Port C

Port C is an 8-bit bi-directional I/O port.

Three I/O memory address locations are allocated for the Port C, one each for the Data Register – PORTC, \$15(\$35), Data Direction Register – DDRC, \$14(\$34) and the Port C Input Pins – PINC, \$13(\$33). The Port C Input Pins address is read-only, while the Data Register and the Data Direction Register are read/write.

All port pins have individually selectable pull-up resistors. The Port C output buffers can sink 20 mA and thus drive LED displays directly. When pins PC0 to PC7 are used as inputs and are externally pulled low, they will source current if the internal pull-up resistors are activated.

The Port C pins have alternate functions related to the optional external memory interface. Port C can be configured to be the high-order address byte during accesses to external Data memory.

When Port C is set to the alternate function by the SRE (External SRAM Enable) bit in the MCUCR (MCU Control Register), the alternate settings override the Data Direction Register.

### Port C Data Register – PORTC

Bit	7	6	5	4	3	2	1	0	
\$15 (\$35)	<b>PORTC7</b>	<b>PORTC6</b>	<b>PORTC5</b>	<b>PORTC4</b>	<b>PORTC3</b>	<b>PORTC2</b>	<b>PORTC1</b>	<b>PORTC0</b>	PORTC
Read/Write	R/W	R/W	R/W	R/W	R/W	R/W	R/W	R/W	
Initial Value	0	0	0	0	0	0	0	0	

### Port C Data Direction Register – DDRC

Bit	7	6	5	4	3	2	1	0	
\$14 (\$34)	<b>DDC7</b>	<b>DDC6</b>	<b>DDC5</b>	<b>DDC4</b>	<b>DDC3</b>	<b>DDC2</b>	<b>DDC1</b>	<b>DDC0</b>	DDRC
Read/Write	R/W	R/W	R/W	R/W	R/W	R/W	R/W	R/W	
Initial Value	0	0	0	0	0	0	0	0	

### Port C Input Pins Address – PINC

Bit	7	6	5	4	3	2	1	0	
\$13 (\$33)	<b>PINC7</b>	<b>PINC6</b>	<b>PINC5</b>	<b>PINC4</b>	<b>PINC3</b>	<b>PINC2</b>	<b>PINC1</b>	<b>PINC0</b>	PINC
Read/Write	R	R	R	R	R	R	R	R	
Initial Value	N/A	N/A	N/A	N/A	N/A	N/A	N/A	N/A	

The Port C Input Pins address (PINC) is not a register; this address enables access to the physical value on each Port C pin. When reading PORTC, the Port C Data Latch is read and when reading PINC, the logical values present on the pins are read.

### Port C as General Digital I/O

All eight pins in Port C have equal functionality when used as digital I/O pins.

PCn, general I/O pin: The DDCn bit in the DDRC Register selects the direction of this pin. If DDCn is set (one), PCn is configured as an output pin. If DDCn is cleared (zero), PCn is configured as an input pin. If PORTCn is set (one) when the pin is configured as an input pin, the MOS pull-up resistor is activated. To switch the pull-up resistor off, PORTCn has to be cleared (zero) or the pin has to be configured as an output pin. The Port C pins are tri-stated when a reset condition becomes active, even if the clock is not running.

**Table 32.** DDCn Effects on Port C Pins<sup>(1)</sup>

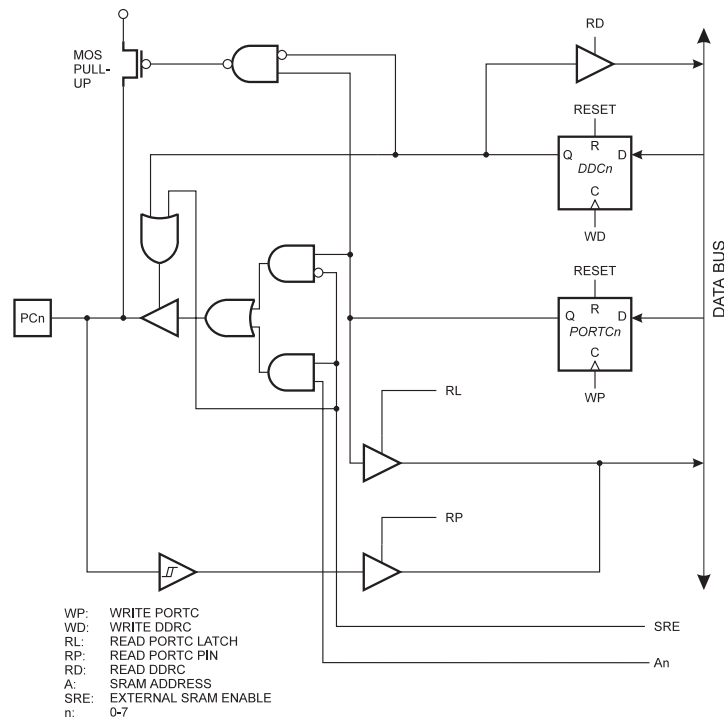
DDCn	PORTCn	I/O	Pull-up	Comment
0	0	Input	No	Tri-state (high-Z)
0	1	Input	Yes	PCn will source current if ext. pulled low
1	0	Output	No	Push-pull Zero Output
1	1	Output	No	Push-pull One Output

Note: 1. n: 7, 6,...,0, pin number

## Port C Schematics

Note that all port pins are synchronized. The synchronization latch is, however, not shown in the figure.

**Figure 63.** Port C Schematic Diagram (Pins PC0 - PC7)



## Port D

Port D is an 8-bit bi-directional I/O port with internal pull-up resistors.

Three I/O address locations are allocated for the Port D, one each for the Data Register – PORTD, \$12(\$32), Data Direction Register – DDRD, \$11(\$31) and the Port D Input Pins – PIND, \$10(\$30). The Port D Input Pins address is read-only, while the Data Register and the Data Direction Register are read/write.

The Port D output buffers can sink 20 mA. As inputs, Port D pins that are externally pulled low will source current if the pull-up resistors are activated.

Some Port D pins have alternate functions as shown in Table 33.

**Table 33.** Port D Pin Alternate Functions

Port Pin	Alternate Function
PD0	RXD0 (UART0 Input Line)
PD1	TXD0 (UART0 Output Line)
PD2	INT0 (External Interrupt0 Input)
PD3	INT1 (External Interrupt1 Input)
PD3	TOSC1 (RTC Oscillator Timer/Counter2)
PD5	TOSC2 (RTC Oscillator Timer/Counter2)/OC1A (Timer/Counter1 Output CompareA Match Output)
PD6	$\overline{WR}$ (Write Strobe to External Memory)
PD7	$\overline{RD}$ (Read Strobe to External Memory)

When the PD5 pin is used for the alternate function (OC1A), the DDRD and PORTD Registers have to be set according to the alternate function description.

### Port D Data Register – PORTD

Bit	7	6	5	4	3	2	1	0	
\$12 (\$32)	<b>PORTD7 PORTD6 PORTD5 PORTD4 PORTD3 PORTD2 PORTD1 PORTD0</b>								PORTD
Read/Write	R/W	R/W	R/W	R/W	R/W	R/W	R/W	R/W	
Initial Value	0	0	0	0	0	0	0	0	

### Port D Data Direction Register – DDRD

Bit	7	6	5	4	3	2	1	0	
\$11 (\$31)	<b>DDD7 DDD6 DDD5 DDD4 DDD3 DDD2 DDD1 DDD0</b>								DDRD
Read/Write	R/W	R/W	R/W	R/W	R/W	R/W	R/W	R/W	
Initial Value	0	0	0	0	0	0	0	0	

### Port D Input Pins Address – PIND

Bit	7	6	5	4	3	2	1	0	
\$10 (\$30)	<b>PIND7 PIND6 PIND5 PIND4 PIND3 PIND2 PIND1 PIND0</b>								PIND
Read/Write	R	R	R	R	R	R	R	R	
Initial Value	N/A	N/A	N/A	N/A	N/A	N/A	N/A	N/A	

The Port D Input Pins address (PIND) is not a register; this address enables access to the physical value on each Port D pin. When reading PORTD, the Port D Data Latch is read and when reading PIND, the logical values present on the pins are read.

### Port D as General Digital I/O

PDn, general I/O pin: The DDDn bit in the DDRD Register selects the direction of this pin. If DDDn is set (one), PDn is configured as an output pin. If DDDn is cleared (zero), PDn is configured as an input pin. If PORTDn is set (one) when configured as an input pin, the MOS pull-up resistor is activated. To switch the pull-up resistor off, the PORTDn

has to be cleared (zero) or the pin has to be configured as an output pin. The Port D pins are tri-stated when a reset condition becomes active, even if the clock is not running.

**Table 34.** DDDn Bits on Port D Pins<sup>(1)</sup>

DDDn	PORTDn	I/O	Pull-up	Comment
0	0	Input	No	Tri-state (high-Z)
0	1	Input	Yes	PDn will source current if ext. pulled low.
1	0	Output	No	Push-pull Zero Output
1	1	Output	No	Push-pull One Output

Notes: 1. n: 7,6...0, pin number

## Alternate Functions of Port D

The alternate pin configuration is as follows:

- **$\overline{RD}$  – Port D, Bit 7**

$\overline{RD}$  is the external Data memory read control strobe.

- **$\overline{WR}$  – Port D, Bit 6**

$\overline{WR}$  is the external Data memory write control strobe.

- **OC1 – Port D, Bit 5**

OC1, Output compare match output: The PD5 pin can serve as an external output when the Timer/Counter1 compare matches. The PD5 pin has to be configured as an output (DDD5 set [one]) to serve this function. See “Timer/Counter1” on page 49 for further details and how to enable the output. The OC1 pin is also the output pin for the PWM mode timer function.

- **TOSC1/TOSC2 – Port D, Bits 5 and 4**

When the AS2 bit in ASSR is set (one) to enable asynchronous clocking of Timer/Counter2, pins PD5 and PD4 are disconnected from the port. In this mode, a crystal Oscillator is connected to the pins and the pins cannot be used as I/O pins.

- **INT1 – Port D, Bit 3**

INT1, External Interrupt source 1: The PD3 pin can serve as an external interrupt source to the MCU. See “MCU Control Register – MCUCR” on page 34 for further details.

- **INT0 – Port D, Bit 2**

INT0, External Interrupt source 0: The PD2 pin can serve as an external interrupt source to the MCU. See “MCU Control Register – MCUCR” on page 34 for further details.

- **TXD0 – Port D, Bit 1**

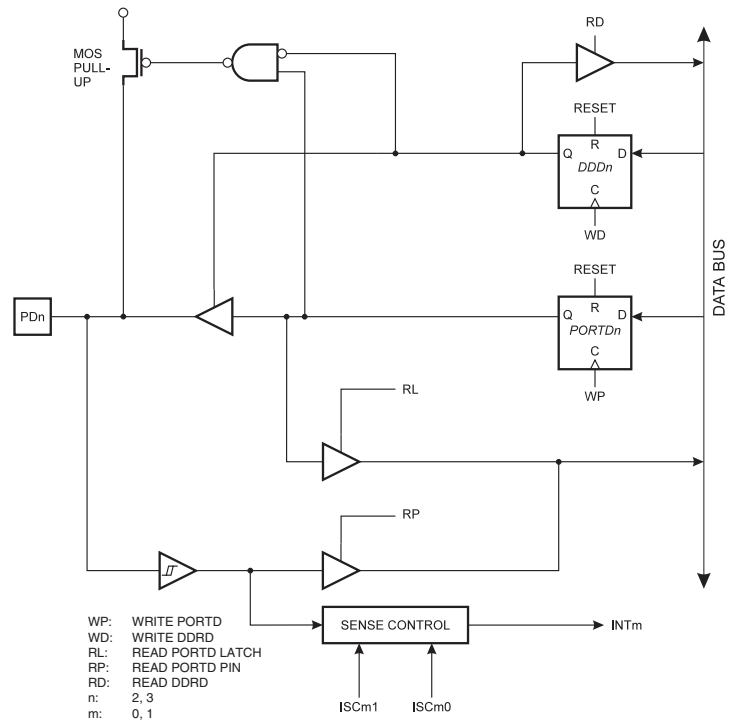
Transmit Data (Data output pin for the UART0). When the UART0 Transmitter is enabled, this pin is configured as an output regardless of the value of DDRD1.

- **RXD0 – Port D, Bit 0**

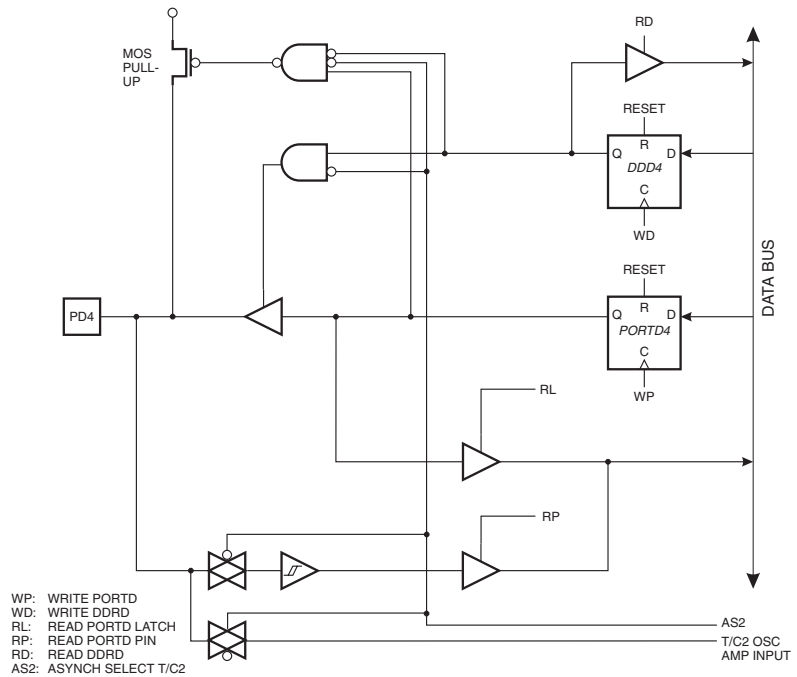
Receive Data (Data input pin for the UART0). When the UART Receiver is enabled, this pin is configured as an input regardless of the value of DDRD0. When the UART0 forces this pin to be an input, a logical “1” in PORTD0 will turn on the internal pull-up.



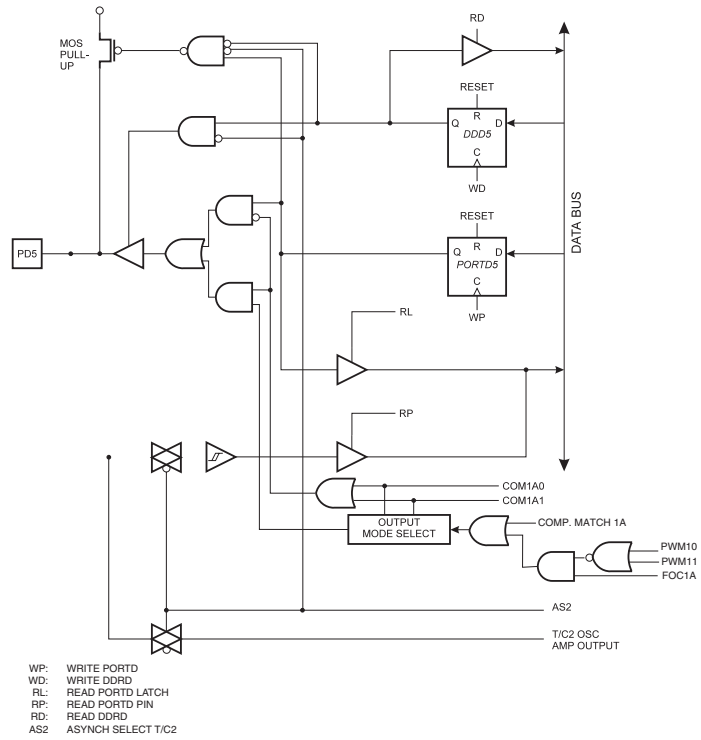
**Figure 66. Port D Schematic Diagram (Pins PD2 and PD3)**



**Figure 67. Port D Schematic Diagram (Pin PD4)**



**Figure 68. Port D Schematic Diagram (Pin PD5)**



**Figure 69. Port D Schematic Diagram (Pin PD6)**

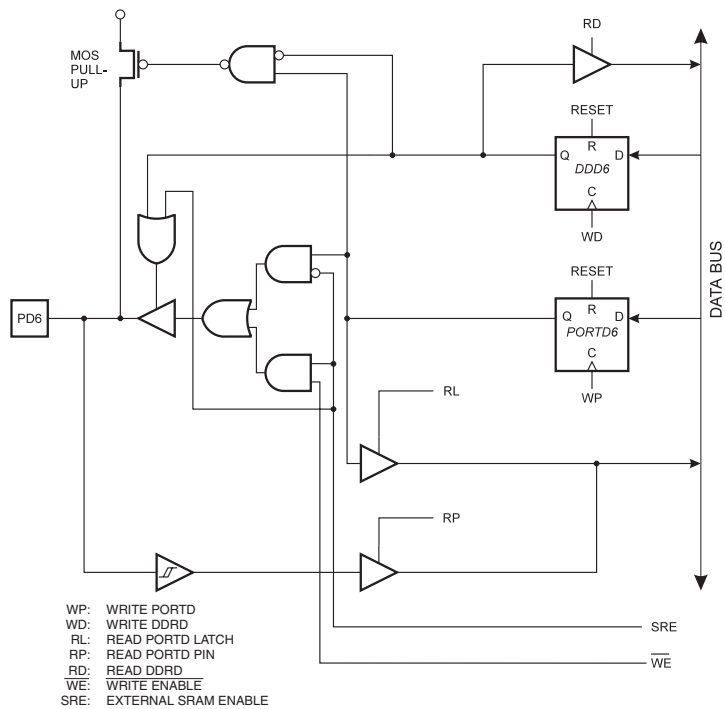
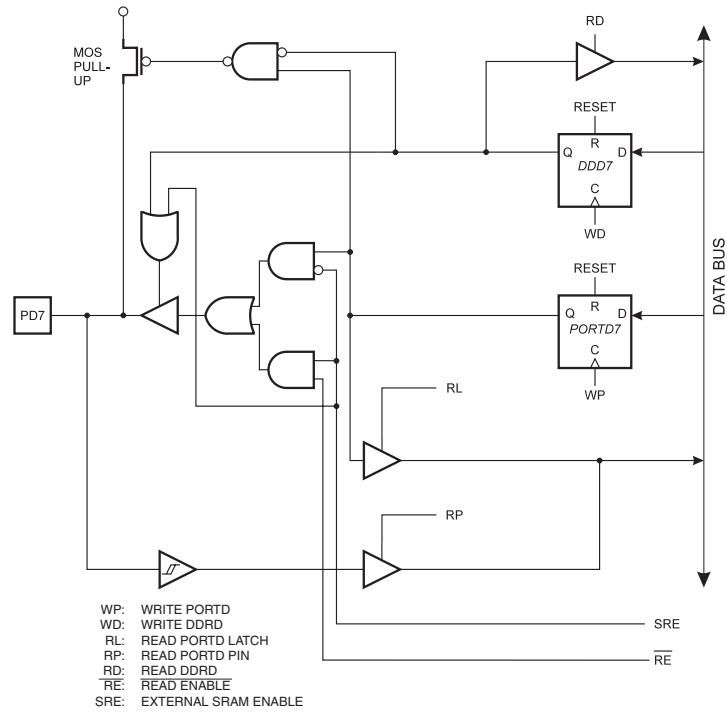


Figure 70. Port D Schematic Diagram (Pin PD7)



## Port E

Port E is a 3-bit bi-directional I/O port with internal pull-up resistors.

Three I/O address locations are allocated for the Port E, one each for the Data Register – PORTE, \$07(\$27), Data Direction Register – DDRE, \$06(\$26) and the Port E Input Pins – PINE, \$05(\$25). The Port E Input Pins address is read-only, while the Data Register and the Data Direction Register are read/write.

The Port E output buffers can sink 20 mA. As inputs, Port E pins that are externally pulled low will source current if the pull-up resistors are activated.

Port E pins have alternate functions as shown in Table 35.

**Table 35.** Port E Pin Alternate Functions<sup>(1)</sup>

Port Pin	Alternate Function
PE0	ICP (Input Capture Pin Timer/Counter1)/INT2 (External Interrupt 2 Input)
PE1	OC1B (Timer/Counter1 Output CompareB Match Output)
PE2	ALE (Address Latch Enable, External Memory)

Note: 1. When the PE1 pin is used for the alternate function, the DDRE and PORTE Registers have to be set according to the alternate function description.

### Port E Data Register – PORTE

Bit	7	6	5	4	3	2	1	0	
\$07 (\$27)	–	–	–	–	–	PORTE2	PORTE1	PORTE0	PORTE
Read/Write	R	R	R	R	R	R/W	R/W	R/W	
Initial Value	0	0	0	0	0	0	0	0	

### Port E Data Direction Register – DDRE

Bit	7	6	5	4	3	2	1	0	
\$06 (\$26)	–	–	–	–	–	DDE2	DDE1	DDE0	DDRE
Read/Write	R	R	R	R	R	R/W	R/W	R/W	
Initial Value	0	0	0	0	0	0	0	0	

### Port E Input Pins Address – PINE

Bit	7	6	5	4	3	2	1	0	
\$05 (\$25)	–	–	–	–	–	PINE2	PINE1	PINE0	PINE
Read/Write	R	R	R	R	R	R	R	R	
Initial Value	0	0	0	0	0	N/A	N/A	N/A	

The Port E Input Pins address (PINE) is not a register; this address enables access to the physical value on each Port E pin. When reading PORTE, the Port E Data Latch is read and when reading PINE, the logical values present on the pins are read.

### Port E as General Digital I/O

PE<sub>n</sub>, general I/O pin: The DDE<sub>n</sub> bit in the DDRE Register selects the direction of this pin. If DDE<sub>n</sub> is set (one), PE<sub>n</sub> is configured as an output pin. If DDE<sub>n</sub> is cleared (zero), PE<sub>n</sub> is configured as an input pin. If PORTE<sub>n</sub> is set (one) when configured as an input pin, the MOS pull-up resistor is activated. To switch the pull-up resistor off, the PORTE<sub>n</sub> has to be cleared (zero) or the pin has to be configured as an output pin. The Port E pins are tri-stated when a reset condition becomes active, even if the clock is not running.

**Table 36.** DDEn Bits on Port E Pins<sup>(1)</sup>

DDEn	PORTEn	I/O	Pull-up	Comment
0	0	Input	No	Tri-state (high-Z)
0	1	Input	Yes	PE <sub>n</sub> will source current if ext. pulled low.
1	0	Output	No	Push-pull Zero Output
1	1	Output	No	Push-pull One Output

Note: 1. n: 2,1,0, pin number.

## Alternate Functions of Port E

The alternate pin configuration is as follows:

- **OC1B – Port E, Bit 2**

OC1B, Output compare match output: The PE2 pin can serve as an external output when the Timer/Counter1 compare matches. The PE2 pin has to be configured as an output (DDE2 set [one]) to serve this function. See “Timer/Counter1” on page 49 for further details. The OC1B pin is also the output pin for the PWM mode timer function.

- **ALE – Port E, Bit 1**

ALE: When the External Memory is enabled, the PE1 pin serves as the Dress Latch Enable. Note that enabling of External Memory will override both the direction and port value. See “Interface to External Memory” on page 84 for a detailed description.

- **ICP/INT2 – Port E, Bit 0**

ICP, Input Capture pin: The PE0 pin can serve as the Input Capture source for Timer/Counter 1. See page 54 for a detailed description.

INT2, External Interrupt source 2: The PE0 pin can serve as an external interrupt source to the MCU. See “Extended MCU Control Register – EMCUCR” on page 36 for further details.

Port E Schematics

Figure 71. Port E Schematic Diagram (Pin PE0)

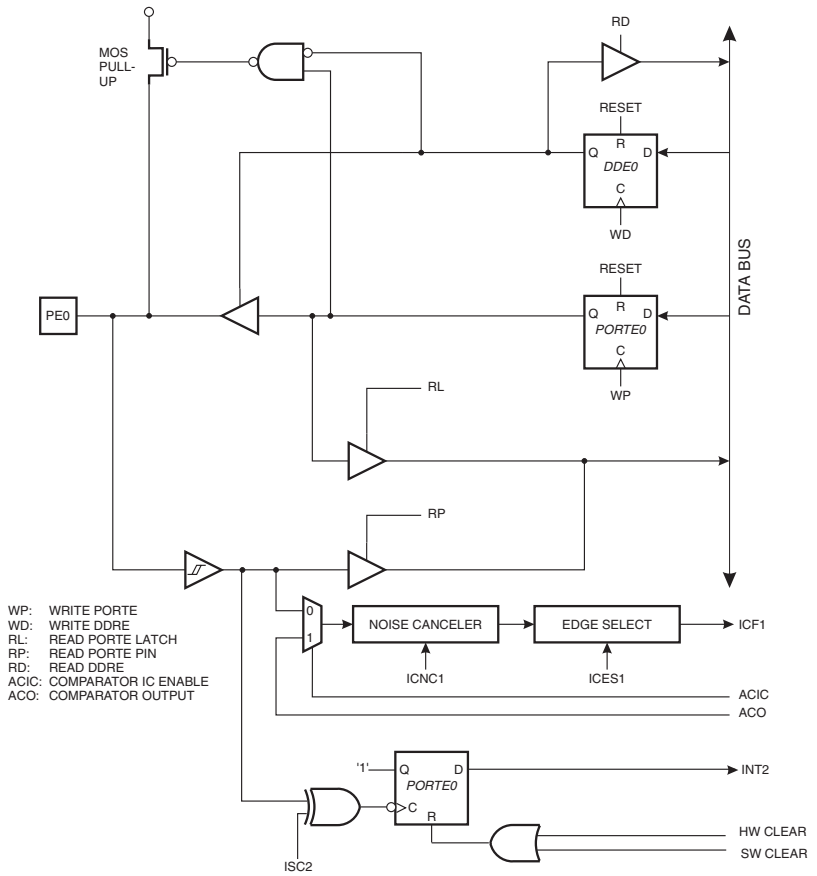


Figure 72. Port E Schematic Diagram (Pin PE1)

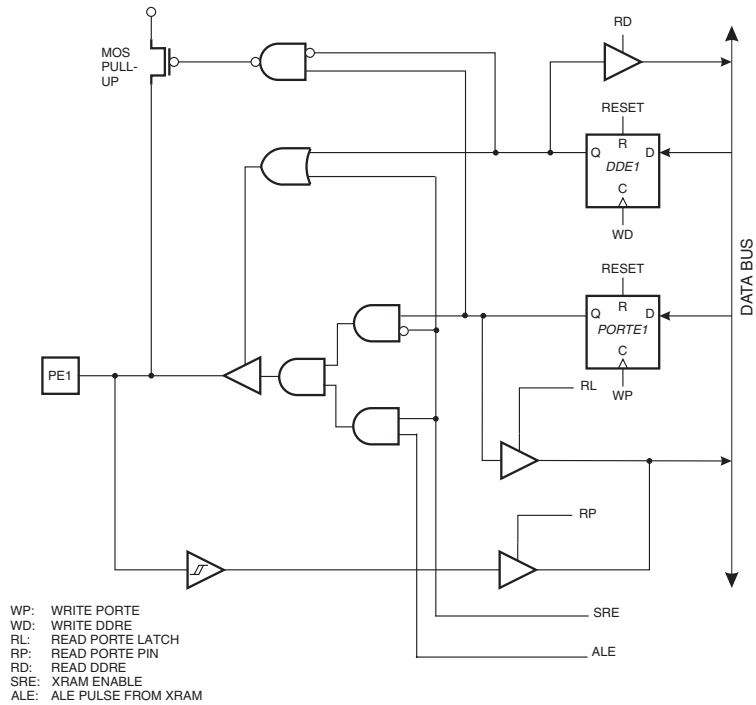
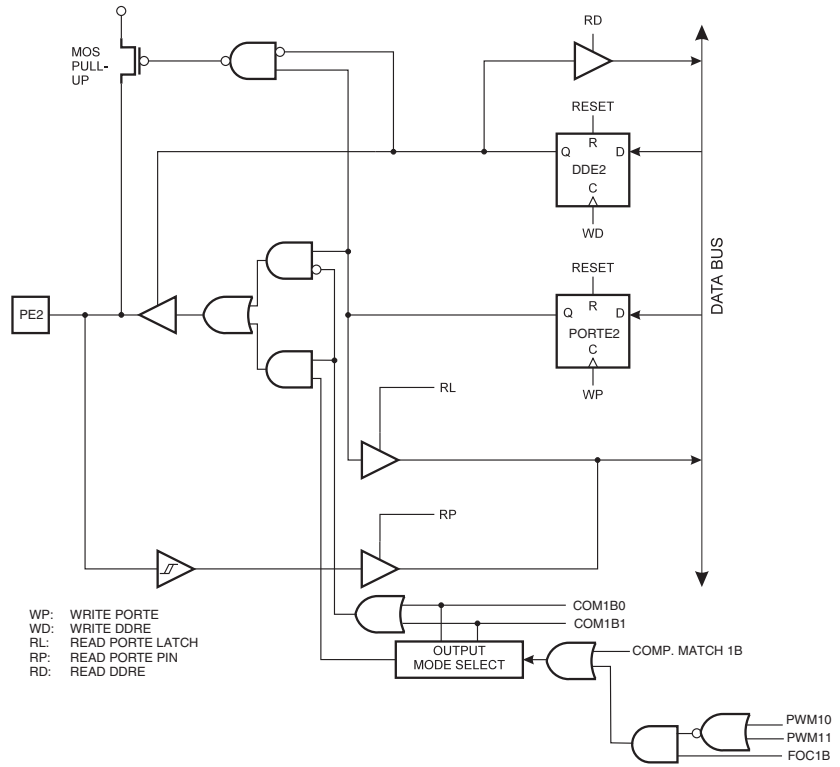


Figure 73. Port E Schematic Diagram (Pin PE2)



## Memory Programming

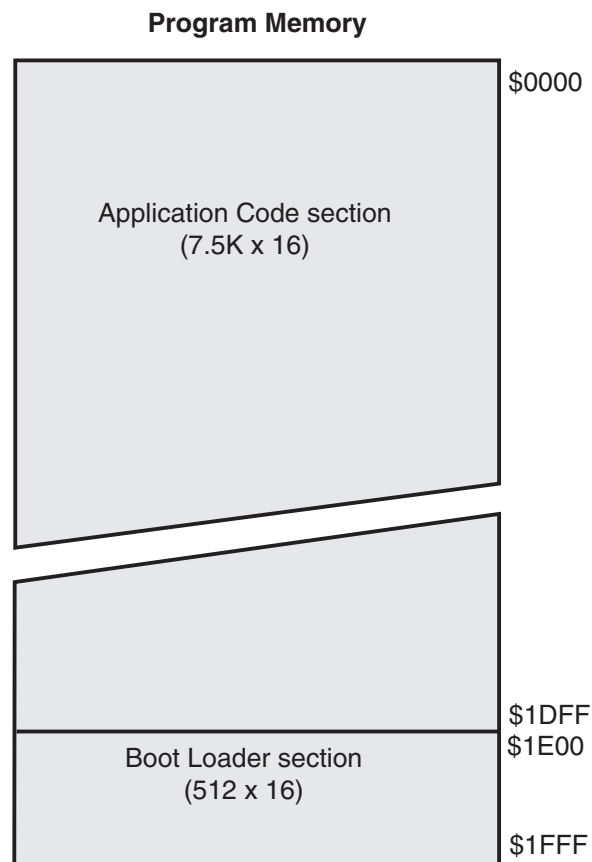
### Boot Loader Support

The ATmega161 provides a mechanism for downloading and uploading program code by the MCU itself. This feature allows flexible application software updates, controlled by the MCU using a Flash-resident Boot Loader program.

The ATmega161 Flash memory is organized in two main sections:

1. The Application Code section (address \$0000 - \$1DFF)
2. The Boot Loader section/Boot block (address \$1E00 - \$1FFF)

**Figure 74.** Memory Sections



The Boot Loader program can use any available data interface and associated protocol, such as UART serial bus interface, to input or output program code and write (program) that code into the Flash memory or read the code from the Program memory.

The program Flash memory is divided into pages that each contain 128 bytes. The Boot Loader Flash section occupies eight pages from \$1E00 to \$1FFF by 16-bit words.

The Store Program Memory (SPM) instruction can access the entire Flash, but it can only be executed from the Boot Loader Flash section. If no Boot Loader capability is needed, the entire Flash is available for application code. The ATmega161 has two separate sets of Boot Lock bits that can be set independently. This gives the user a unique flexibility to select different levels of protection. The user can elect to:

- Protect the entire Flash from a software update by the Boot Loader program
- Only protect the Boot Loader section from a software update by the Boot Loader program
- Only protect the Application Code section from a software update by the Boot Loader program
- Allow software update in the entire Flash

See Table 37 and Table 38 for further details. The Boot Lock bits can be set in software and in Serial or Parallel Programming mode, but they can only be cleared by a Chip Erase command.

**Table 37.** Boot Lock Bit0 Protection Modes (Application Code Section)<sup>(1)</sup>

BLB0 Mode	BLB02	BLB01	Protection
1	1	1	No restrictions for SPM, LPM accessing Application Code section
2	1	0	SPM is not allowed to write to the Application Code section.
3	0	0	SPM is not allowed to write to the Application Code section, and LPM executing from the Boot Loader section is not allowed to read from the Application Code section.
4	0	1	LPM executing from the Boot Loader section is not allowed to read from the Application Code section.

Note: 1. “1” = unprogrammed, “0” = programmed

**Table 38.** Boot Lock Bit1 Protection Modes (Boot Loader Section)<sup>(1)</sup>

BLB1 Mode	BLB12	BLB1 1	Protection
1	1	1	No restrictions for SPM, LPM accessing Boot Loader section
2	1	0	SPM is not allowed to write to the Boot Loader section.
3	0	0	SPM is not allowed to write to the Boot Loader section, and LPM executing from the Application Code section is not allowed to read from the Boot Loader section.
4	0	1	LPM executing from the Application Code section is not allowed to read from the Boot Loader section.

Note: 1. “1” means unprogrammed, “0” means programmed

## Entering the Boot Loader Program

Entering the Boot Loader takes place by a jump or call from the application program. This may be initiated by some trigger such as a command received via UART or SPI interface. Alternatively, the Boot Reset Fuse (BOOTRST) can be programmed so that the Reset Vector is pointing to address \$1E00 after a reset. In this case, the Boot Loader is started after the reset. After the application code is loaded, the program can start executing the application code. Note that the fuses cannot be changed by the MCU itself. This means that once the Boot Reset Fuse is programmed, the Reset Vector will always point to the Boot Loader Reset and the fuse can only be changed through the serial or parallel programming interface. The BOOTRST fuse can also be locked by programming LB1. When LB1 is programmed it is not possible to change the BOOTRST fuse unless a Chip Erase command is performed first.

**Table 39.** Boot Reset Fuse, BOOTRST<sup>(1)</sup>

BOOTRST	Reset Address
1	Reset Vector = Application Reset (address \$0000)
0	Reset Vector = Boot Loader Reset (address \$1E00)

Note: 1. “1” means unprogrammed, “0” means programmed

## Capabilities of the Boot Loader

The program code within the Boot Loader section has the ability to read from and write into the entire Flash, including the Boot Loader Memory. This allows the user to update both the Application code and the Boot Loader code that handles the software update. The Boot Loader can thus even modify itself, and it can also erase itself from the code if the feature is not needed anymore. Special care must be taken if the user allows the Boot Loader section to be updated by leaving Boot Lock bit11 unprogrammed. An accidental write to the Boot Loader itself can corrupt the entire Boot Loader, and further software updates might be impossible. If it is not needed to change the Boot Loader software itself, it is recommended that the Boot Lock bit 11 be programmed to protect the Boot Loader software from software changes.

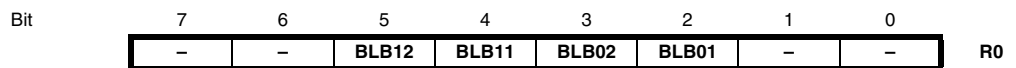
## Self-programming the Flash

Programming of the Flash is executed one page at a time. The Flash page must be erased first for correct programming. The general Write Lock (Lock Bit 2) does not control the programming of the Flash memory by SPM instruction. Similarly, the Read/Write Lock (Lock Bit 1) does not control reading or writing by LPM/SPM, if it is attempted.

The Program memory can only be updated page-by-page, not word by word. One page is 128 bytes (64 words). The Program memory will be modified by first performing page erase, then by filling the temporary page buffer one word at a time using SPM, and then by executing page write. If only part of the page needs to be changed, the other parts must be stored (for example, in the temporary page buffer) before the erase, and then be rewritten. The temporary page buffer can be accessed in a random sequence. The CPU is halted both during page erase and during page write and the SPMEN bit in the SPMCR Register will be auto-cleared. For future compatibility, however, it is recommended that the user software verify that the SPMEN bit is cleared before starting a new page erase, page write, or before writing the Lock bits command (see code examples below). It is essential that the page address used in both the page erase and page write operation is addressing the same page.

## Setting the Boot Loader Lock bits by SPM

To set the Boot Loader Lock bits, write the desired data to R0, write “1001” to SPMCR, and execute SPM within four clock cycles after writing SPMCR. The only accessible Lock bits are the Boot Lock bits that may prevent the Application Code and Boot Loader sections from any software update by the MCU. See Table 37 and Table 38 for how the different settings of the Boot Loader bits affect the Flash access.



If bit5 - bit2 in R0 is cleared (zero), the corresponding Boot Lock bit will be programmed if an SPM instruction is executed within four cycles after BLBSET and SPMEN are set in SPMCR.

## Performing Page Erase by SPM

To execute a page erase, set up the address in the Z-pointer, write “0011” to SPMCR, and execute SPM within four clock cycles after writing SPMCR. The data in R1 and R0 are ignored. The page address must be written to Z13:Z7. Other bits in the Z-pointer will be ignored during this operation.

## Fill the Temporary Buffer

To write an instruction word, set up the address in the Z-pointer and data in R1:R0, write “0001” to SPMCR, and execute SPM within four clock cycles after writing SPMCR. The content of Z6:Z1 is used to address the data in the temporary buffer. Z13:Z7 must point to the page that is supposed to be written.

## Perform a Page Write

To execute a page write, set up the address in the Z-pointer, write “0101” to SPMCR, and execute SPM within four clock cycles after writing SPMCR. The data in R1 and R0 are ignored. The page address must be written to Z13:Z7. During this operation, Z6:Z0 must be zero to ensure that the page is written correctly. When a page write operation is completed, the Z-pointer will point to the first word in the successive page.

### Code Example

```

Wait:  in   r16,SPMCR ; read SPMCR Register
      sbrc r16,SPMEN ; Wait for SP MEN to be cleared (indicates that previous
                    ; write operation is completed)
      rjmp Wait      ; if not cleared, keep waiting
      ldi  r16,(1<<PGWRT) + (1<<SPMEN) ; The previous writing is completed,
                    ; set up for next erase
      out  SPMCR,r16 ; output to register
      spm                    ; start the erase operation
    
```

## Addressing the FLASH during Self-programming

The Z-pointer is used to address the SPM commands.

Bit	15	14	13	12	11	10	9	8	
\$1F (\$1F)	Z15	Z14	Z13	Z12	Z11	Z10	Z9	Z8	ZH
\$1E (\$1E)	Z7	Z6	Z5	Z4	Z3	Z2	Z1	Z0	ZL
	7	6	5	4	3	2	1	0	

Z15:Z14 always ignored

Z13:Z7 page select, for page erase, page write

Z6:Z1 word select, for filling temp buffer (must be zero during page write operation)

Z0 should be zero for all SPM commands, byte select for the LPM instruction

The only operation that does not use the Z-pointer is setting the Boot Loader Lock bits. The content of the Z-pointer is ignored and will have no effect on the operation.

Note that the page erase and page write operation are addressed independently. Therefore, it is of major importance that the Boot Loader software addresses the same page in both the page erase and page write operations.

The LPM instruction also uses the Z-pointer to store the address. Since this instruction addresses the Flash byte-by-byte, the LSB (bit Z0) of the Z-pointer is also used. See page 16 for a detailed description.

Accidental writing into Flash program by the SPM instruction is prevented by setting up an “SPM enable time window”. All accesses are executed by first setting I/O bits, and then by executing SPM within four clock cycles. The I/O Register that controls the SPM accesses is defined below.

## Store Program Memory Control Register – SPMCR

The Store Program Memory Control Register contains the control bits needed to control the programming of the Flash from internal code execution.

Bit	7	6	5	4	3	2	1	0	
\$37 (\$57)	–	–			BLBSET	PGWRT	PGERS	SPMEN	SPMCR
Read/Write	R	R	R	R	R/W	R/W	R/W	R/W	
Initial Value	0	0	0	0	0	0	0	0	

- **Bits 7..4 – Res: Reserved Bits**

These bits are reserved bits in the ATmega161 and always read as zero.

- **Bit 3 – BLBSET: Boot Lock Bit Set**

If this bit is set at the same time as SPMEN, the next SPM instruction within four clock cycles sets Boot Lock bits according to the data in R0. The data in R1 and the address in the Z-pointer are ignored. The BLBSET bit will auto-clear upon completion of Lock bit set, or if no SPM instruction is executed within four clock cycles. The CPU is halted during Lock bit setting. Only a chip erase can clear the Lock bits.

An LPM instruction within four cycles after BLBSET and SPMEN are set in the SPMCR Register will put either the Lock bits or the Fuse bits (depending on the Z0 in the Z-pointer) into the destination register. See “Reading the Fuse and Lock bits from Software” for details.

- **Bit 2 – PGWRT: Page Write**

If this bit is set at the same time as SPMEN, the next SPM instruction within four clock cycles executes page write, with the data stored in the temporary buffer. The page address is taken from the high part of the Z-pointer. The data in R1 and R0 are ignored. The PGWRT bit will auto-clear upon completion of a page write or if no SPM instruction is executed within four clock cycles. The CPU is halted during the entire page write operation.

- **Bit 1 – PGERS: Page Erase**

If this bit is set at the same time as SPMEN, the next SPM instruction within four clock cycles executes a page erase. The page address is taken from the high part of the Z-pointer. The data in R1 and R0 are ignored. The PGERS bit will auto-clear upon completion of a page erase or if no SPM instruction is executed within four clock cycles. The CPU is halted during the entire page erase operation.

- **Bit 0 – SPMEN: Store Program Memory Enable**

This bit enables the SPM instruction for the next four clock cycles. If set together with either BLBSET, PGWRT or PGERS, the following SPM instruction will have a special meaning (see description above). If only SPMEN is set, the following SPM instruction will store the value in R1:R0 in the temporary page buffer addressed by the Z-pointer. The LSB of the Z-pointer is ignored. The SPMEN bit will auto-clear upon completion of an SPM instruction or if no SPM instruction is executed within four clock cycles.

Writing any combination other than “1001”, “0101”, “0011” or “0001” in the lower four bits, or writing to the I/O Register when any bits are set, will have no effect.

## EEPROM Write Prevents Writing to SPMCR

Note that an EEPROM write operation will block all software programming to Flash. Reading the Fuse and Lock bits from software will also be prevented during the EEPROM write operation. It is recommended that the user check the status bit (EWE) in the EECR Register and verify that the bit is cleared before writing to the SPMCR Register.

## Reading the Fuse and Lock bits from Software

It is possible to read both the Fuse and Lock bits from software. To read the Lock bits, load the Z-pointer with \$0001 and set the BLBSET and SPEN bits in SPMCR. If an LPM instruction is executed within three CPU cycles after the BLBSET and SPEN bits are set in SPMCR, the Lock bits will be written to the destination register. The BLBSET and SPEN bits will auto-clear upon completion of reading the Lock bits or if no LPM/SPM instruction is executed within three/four CPU cycles. When BLBSET and SPEN are cleared, LPM will work as described in "Constant Addressing Using the LPM Instruction" on page 16 and in the Instruction Set manual.

Bit	7	6	5	4	3	2	1	0	
	-	-	BLB12	BLB11	BLB02	BLB01	LB2	LB1	R0/Rd

The algorithm for reading the Fuse bits is similar to the one described above for reading the Lock bits. But when reading the Fuse bits, load \$0000 in the Z-pointer. When an LPM instruction is executed within three cycles after the BLBSET and SPEN bits are set in the SPMCR, the Fuse bits can be read in the destination register as shown below.

Bit	7	6	5	4	3	2	1	0	
	-	BOOTRST	SPIEN	SUT	-	CKSEL[2]	CKSEL[1]	CKSEL[0]	R0/Rd

Fuse and Lock bits that are programmed will be read as zero.

## Program Memory Lock bits

The ATmega161 MCU provides six Lock bits that can be left unprogrammed (“1”) or can be programmed (“0”) to obtain the additional features listed in Table 40. The Lock bits can only be erased to “1” with the Chip Erase command.

**Table 40.** Lock Bit Protection Modes <sup>(1)</sup>

Memory Lock bits			Protection Type
LB Mode	LB1	LB2	
1	1	1	No memory lock features enabled
2	0	1	Further programming of the Flash and EEPROM is disabled in parallel and Serial Programming modes. The Fuse bits are locked in both Serial and Parallel Programming modes. <sup>(1)</sup>
3	0	0	Further programming and verification of the Flash and EEPROM is disabled in parallel and Serial Programming modes. The Fuse bits are locked in both Serial and Parallel Programming modes. <sup>(1)</sup>
BLB0 Mode	BLB02	BLB01	
1	1	1	No restrictions for SPM, LPM accessing the Application Code section
2	1	0	SPM is not allowed to write to the Application Code section.
3	0	0	SPM is not allowed to write to the Application Code section and LPM executing from Boot Loader section is not allowed to read from the Application Code section.
4	0	1	LPM executing from the Boot Loader section is not allowed to read from the Application Code section.
BLB1 Mode	BLB12	BLB11	
1	1	1	No restrictions for SPM, LPM accessing the Boot Loader section
2	1	0	SPM is not allowed to write the Boot Loader section.
3	0	0	SPM is not allowed to write to the Boot Loader section and LPM executing from the Application Code section is not allowed to read from the Boot Loader section.
4	0	1	LPM executing from the Application Code section is not allowed to read from the Boot Loader section.

Note: 1. Program the Fuse bits before programming the Lock bits.

## Fuse bits

The ATmega161 has six Fuse bits: BOOTRST, SPIEN, SUT, and CKSEL [2:0].

- When BOOTRST is programmed (“0”), the Reset Vector is set to address \$1E00, which is the first address location in the Boot Loader section of the Flash. If the BOOTRST is unprogrammed (“1”), the Reset Vector is set to address \$0000. Default value is unprogrammed (“1”).
- When the SPIEN Fuse is programmed (“0”), Serial Program and Data Downloading is enabled. Default value is programmed (“0”). The SPIEN Fuse is not accessible in Serial Programming mode.
- The SUT Fuse changes the start-up times. Default value is unprogrammed (“1”).

- CKSEL2..0: See Table 4, “Reset Delay Selections<sup>(3)</sup>,” on page 26, for which combination of CKSEL2..0 to use. Default value is “010”.

The status of the Fuse bits is not affected by Chip Erase. Note that the Fuse bits are locked if Lock bit1 (LB1) or Lock bit2 (LB2) is programmed. Program the Fuse bits before programming the Lock bits.

## Signature Bytes

All Atmel microcontrollers have a 3-byte signature code that identifies the device. This code can be read in both Serial and Parallel modes. The three bytes reside in a separate address space, and for the ATmega161 they are:

1. \$000: \$1E (indicates manufactured by Atmel)
2. \$001: \$94 (indicates 16 KB Flash memory)
3. \$002: \$01 (indicates ATmega161 device when \$001 is \$94)

## Programming the Flash and EEPROM

Atmel’s ATmega161 offers 16K bytes of In-System Reprogrammable Flash Program memory and 512 bytes of EEPROM Data memory.

The ATmega161 is normally shipped with the On-chip Flash program and EEPROM Data memory arrays in the erased state (i.e., contents = \$FF) and ready to be programmed. This device supports a High-voltage (12V) Parallel Programming mode and a Low-voltage Serial Programming mode. The +12V is used for programming enable only, and no current of significance is drawn by this pin. The Serial Programming mode provides a convenient way to download the program and data into the ATmega161 inside the user’s system.

The Program memory array on the ATmega161 is organized as 128 pages of 128 bytes each. When programming the Flash, the program data is latched into a page buffer. This allows one page of program data to be programmed simultaneously in either Programming mode.

The EEPROM Data Memory array on the ATmega161 is programmed byte-by-byte in either Programming mode. An auto-erase cycle is provided with the self-timed EEPROM programming operation in the Serial Programming mode.

During programming, the supply voltage must be in accordance with Table 41.

**Table 41.** Supply Voltage during Programming

Part	Serial Programming	Parallel Programming
ATmega161L	2.7 - 5.5V	4.5 - 5.5V
ATmega161	4.0 - 5.5V	4.5 - 5.5V

## Parallel Programming

This section describes how to parallel program and verify Flash Program memory, EEPROM Data memory, Lock bits and Fuse bits in the ATmega161. Pulses are assumed to be at least 500 ns unless otherwise noted.

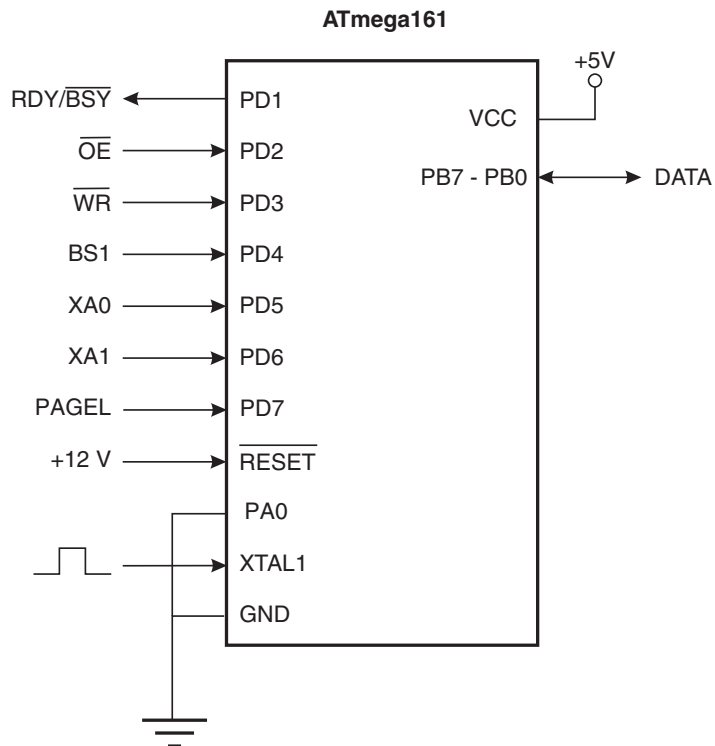
### Signal Names

In this section, some pins of the ATmega161 are referenced by signal names describing their functionality during parallel programming (see Figure 75 and Table 42). Pins not described in the following table are referenced by pin name.

The XA1/XA0 pins determine the action executed when the XTAL1 pin is given a positive pulse. The bit codings are shown in Table 43.

When pulsing  $\overline{WR}$  or  $\overline{OE}$ , the command loaded determines the action executed. The command is a byte where the different bits are assigned functions as shown in Table 44.

**Figure 75.** Parallel Programming



**Table 42.** Pin Name Mapping

Signal Name in Programming Mode	Pin Name	I/O	Function
RDY/BSY	PD1	O	0: Device is busy programming; 1: Device is ready for new command
$\overline{OE}$	PD2	I	Output Enable (Active low)
$\overline{WR}$	PD3	I	Write Pulse (Active low)
BS1	PD4	I	Byte Select 1 ("0" selects Low byte, "1" selects High byte)
XA0	PD5	I	XTAL Action Bit 0
XA1	PD6	I	XTAL Action Bit 1

**Table 42.** Pin Name Mapping

Signal Name in Programming Mode	Pin Name	I/O	Function
PAGEL	PD7	I	Program Memory Page Load
BS2	PA0	I	Byte Select 2 (Always low)
DATA	PB7 - 0	I/O	Bi-directional Data Bus (Output when $\overline{OE}$ is low)

**Table 43.** XA1 and XA0 Coding

XA1	XA0	Action when XTAL1 is Pulsed
0	0	Load Flash or EEPROM Address (High or low address byte determined by BS1)
0	1	Load Data (High or low data byte for Flash determined by BS1)
1	0	Load Command
1	1	No Action, Idle

**Table 44.** Command Byte Bit Coding

Command Byte	Command Executed
1000 0000	Chip Erase
0100 0000	Write Fuse bits
0010 0000	Write Lock bits
0001 0000	Write Flash
0001 0001	Write EEPROM
0000 1000	Read Signature Bytes
0000 0100	Read Fuse and Lock bits
0000 0010	Read Flash
0000 0011	Read EEPROM

## Enter Programming Mode

The following algorithm puts the device in Parallel Programming mode:

1. Apply 4.5 - 5.5V between  $V_{CC}$  and GND.
2. Set  $\overline{RESET}$  and BS pins to "0" and wait at least 500 ns.
3. Apply 11.5 - 12.5V to  $\overline{RESET}$ , and wait for at least 500 ns.

## Chip Erase

The Chip Erase will erase the Flash and EEPROM memories plus Lock bits. The Lock bits are not reset until the Program memory has been completely erased. The Fuse bits are not changed. A Chip Erase must be performed before the Flash is reprogrammed.

Load Command "Chip Erase"

1. Set XA1, XA0 to "10". This enables command loading.
2. Set BS1 to "0".
3. Set DATA to "1000 0000". This is the command for Chip Erase.
4. Give  $\overline{WR}$  a negative pulse. This starts the Chip Erase.  $RDY/\overline{BSY}$  goes low.
5. Wait until  $RDY/\overline{BSY}$  goes high before loading a new command.



## Programming the Flash

The Flash is organized as 128 pages of 128 bytes each. When programming the Flash, the program data is latched into a page buffer. This allows one page of program data to be programmed simultaneously. The following procedure describes how to program the entire Flash memory:

### A. Load Command "Write Flash"

1. Set XA1, XA0 to "10". This enables command loading.
2. Set BS1 to "0".
3. Set DATA to "0001 0000". This is the command for Write Flash.
4. Give XTAL1 a positive pulse. This loads the command.

### B. Load Address Low Byte

1. Set XA1, XA0 to "00". This enables address loading.
2. Set BS1 to "0". This selects low address.
3. Set DATA = Address Low byte (\$00 - \$FF).
4. Give XTAL1 a positive pulse. This loads the address Low byte.

### C. Load Data Low Byte

1. Set BS1 to "0". This selects low data byte.
2. Set XA1, XA0 to "01". This enables data loading.
3. Set DATA = Data Low byte (\$00 - \$FF).
4. Give XTAL1 a positive pulse. This loads the data byte.

### D. Latch Data Low Byte

Give PAGEL a positive pulse. This latches the data Low byte.  
(See Figure 76 for signal waveforms.)

### E. Load Data High Byte

1. Set BS1 to "1". This selects high data byte.
2. Set XA1, XA0 to "01". This enables data loading.
3. Set DATA = Data High byte (\$00 - \$FF).
4. Give XTAL1 a positive pulse. This loads the data byte.

### F. Latch Data High Byte

Give PAGEL a positive pulse. This latches the data High byte.

### G. Repeat "B" through "F" 64 times to fill the page buffer.

To address a page in the Flash, seven bits are needed (128 pages). The five most significant bits are read from address High byte as described in section "H" below. The two least significant page address bits, however, are the two most significant bits (bit7 and bit6) of the latest loaded address Low byte as described in section "B".

### H. Load Address High byte

1. Set XA1, XA0 to "00". This enables address loading.
2. Set BS1 to "1". This selects high address.
3. Set DATA = Address High byte (\$00 - \$1F).
4. Give XTAL1 a positive pulse. This loads the address High byte.

### I. Program Page

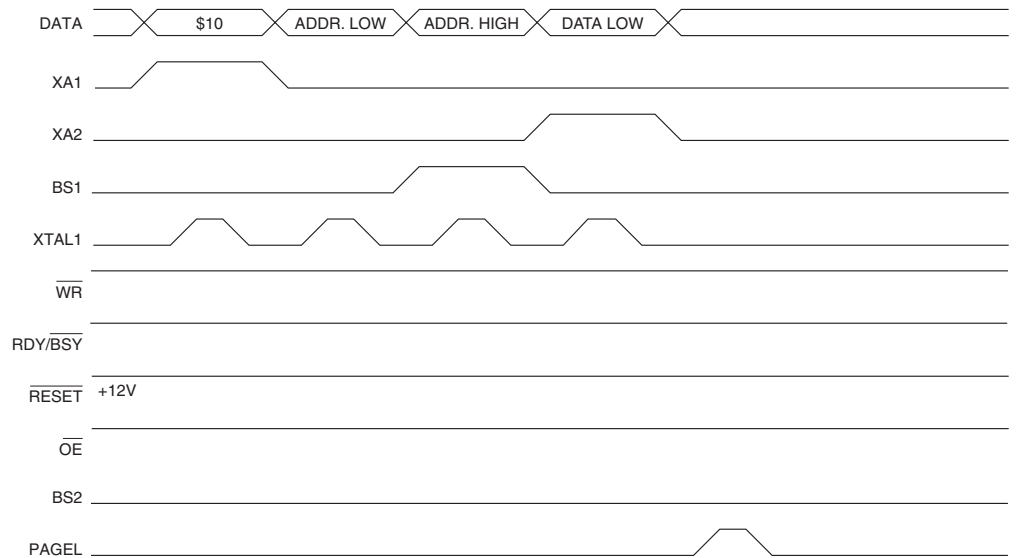
1. Give  $\overline{WR}$  a negative pulse. This starts programming of the entire page of data.  $RDY/\overline{BSY}$  goes low.
2. Wait until  $RDY/\overline{BSY}$  goes high.  
(See Figure 77 for signal waveforms.)

### J. End Page Programming

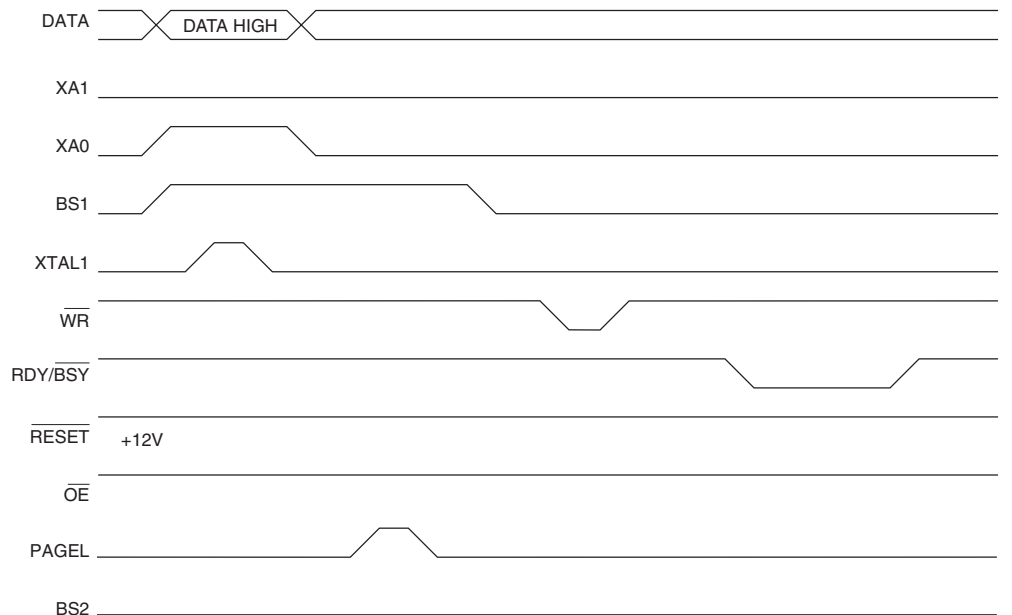
1. Set XA1, XA0 to "10". This enables command loading.
2. Set DATA to "0000 0000". This is the command for No Operation.
3. Give XTAL1 a positive pulse. This loads the command, and the internal write signals are reset.

K. Repeat "A" through "J" 128 times or until all data have been programmed.

**Figure 76.** Programming the Flash Waveforms



**Figure 77.** Programming the Flash Waveforms (Continued)



## Programming the EEPROM

The programming algorithm for the EEPROM Data memory is as follows (refer to “Programming the Flash” for details on command, address and data loading):

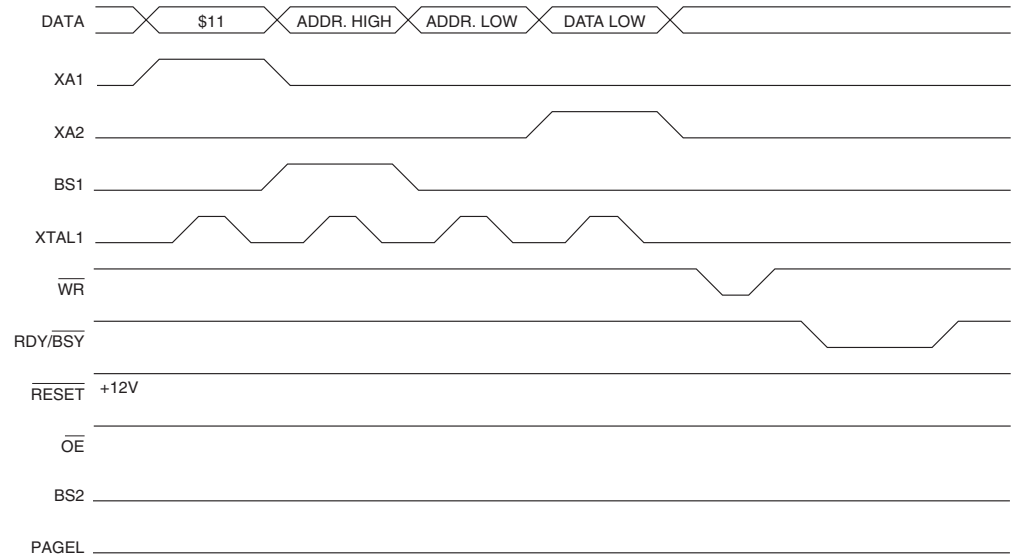
1. A: Load Command “0001 0001”.
  2. H: Load Address High Byte (\$00 - \$01)
  3. B: Load Address Low Byte (\$00 - \$FF)
  4. E: Load Data Low Byte (\$00 - \$FF)
- L: Write Data Low Byte
1. Set BS to “0”. This selects low data.
  2. Give  $\overline{WR}$  a negative pulse. This starts programming of the data byte.  $RDY/\overline{BSY}$  goes low.
  3. Wait until  $RDY/\overline{BSY}$  goes high before programming the next byte. (See Figure 78 for signal waveforms.)

The loaded command and address are retained in the device during programming. For efficient programming, the following should be considered:

- The command needs to be loaded only once when writing or reading multiple memory locations.
- Address High byte only needs to be loaded before programming a new 256-word page in the EEPROM.
- Skip writing the data value \$FF, that is, the contents of the entire EEPROM after a Chip Erase.

These considerations also apply to Flash, EEPROM and Signature bytes reading.

**Figure 78.** Programming the EEPROM Waveforms



## Reading the Flash

The algorithm for reading the Flash memory is as follows (refer to “Programming the Flash” on page 120 for details on command and address loading):

1. A: Load Command “0000 0010”.
2. H: Load Address High Byte (\$00 - \$1F)
3. B: Load Address Low Byte (\$00 - \$FF)
4. Set  $\overline{OE}$  to “0”, and BS1 to “0”. The Flash word Low byte can now be read at DATA.
5. Set BS to “1”. The Flash word High byte can now be read at DATA.
6. Set  $\overline{OE}$  to “1”.

## Reading the EEPROM

The algorithm for reading the EEPROM memory is as follows (refer to “Programming the Flash” on page 120 for details on command and address loading):

1. A: Load Command “0000 0011”.
2. H: Load Address High Byte (\$00 - \$01)
3. B: Load Address (\$00 - \$FF)
4. Set  $\overline{OE}$  to “0”, and BS1 to “0”. The EEPROM Data byte can now be read at DATA.
5. Set  $\overline{OE}$  to “1”.

## Programming the Fuse Bits

The algorithm for programming the Fuse bits is as follows (refer to “Programming the Flash” on page 120 for details on command and data loading):

1. A: Load Command “0100 0000”.
2. C: Load Data Low Byte. Bit n = “0” programs and bit n = “1” erases the Fuse bit.  
 Bit 6 = BOOTRST Fuse bit  
 Bit 5 = SPIEN Fuse bit  
 Bit 4 = SUT Fuse bit  
 Bit 3 = “1”. This bit is reserved and must be left unprogrammed (“1”).  
 Bits 2 - 0 = CKSEL2..0 Fuse bits  
 Bit 7 = “1”. This bit is reserved and should be left unprogrammed (“1”).
3. Give  $\overline{WR}$  a negative pulse and wait for RDY/ $\overline{BSY}$  to go high.

## Programming the Lock Bits

The algorithm for programming the Lock bits is as follows (refer to “Programming the Flash” on page 120 for details on command and data loading):

1. A: Load Command “0010 0000”.
2. D: Load Data Low Byte. Bit n = “0” programs the Lock bit.  
 Bit 5 = Boot Lock Bit12  
 Bit 4 = Boot Lock Bit11  
 Bit 3 = Boot Lock Bit02  
 Bit 2 = Boot Lock Bit01  
 Bit 1 = Lock Bit2  
 Bit 0 = Lock Bit1  
 Bits 7 - 6 = “1”. These bits are reserved and should be left unprogrammed (“1”).
3. L: Write Data Low Byte.

The Lock bits can only be cleared by executing Chip Erase.



**Table 45.** Parallel Programming Characteristics,  $T_A = 25^\circ\text{C} \pm 10\%$ ,  $V_{CC} = 5\text{V} \pm 10\%$ <sup>(1)(2)(3)</sup>

Symbol	Parameter	Min	Typ	Max	Units
$V_{PP}$	Programming Enable Voltage	11.5		12.5	V
$I_{PP}$	Programming Enable Current			250	$\mu\text{A}$
$t_{DVXH}$	Data and Control Valid before XTAL1 High	67			ns
$t_{XHXL}$	XTAL1 Pulse Width High	67			ns
$t_{XLDX}$	Data and Control Hold after XTAL1 Low	67			ns
$t_{XLWL}$	XTAL1 Low to $\overline{WR}$ Low	67			ns
$t_{BVXH}$	BS1 Valid before XTAL1 High	67			ns
$t_{PHPL}$	PAGEL Pulse Width High	67			ns
$t_{PLBX}$	BS1 Hold after PAGEL Low	67			ns
$t_{PLWL}$	PAGEL Low to $\overline{WR}$ Low	67			ns
$t_{BVWL}$	BS1 Valid to $\overline{WR}$ Low	67			ns
$t_{RHBX}$	BS1 Hold after $\text{RDY}/\overline{\text{BSY}}$ High	67			ns
$t_{WLWH}$	$\overline{WR}$ Pulse Width Low	67			ns
$t_{WLRL}$	$\overline{WR}$ Low to $\text{RDY}/\overline{\text{BSY}}$ Low	0		2.5	$\mu\text{s}$
$t_{WLRH}$	$\overline{WR}$ Low to $\text{RDY}/\overline{\text{BSY}}$ High <sup>(1)</sup>	1		1.7	ms
$t_{WLRH\_CE}$	$\overline{WR}$ Low to $\text{RDY}/\overline{\text{BSY}}$ High for Chip Erase <sup>(2)</sup>	16		28	ms
$t_{WLRH\_FLASH}$	$\overline{WR}$ Low to $\text{RDY}/\overline{\text{BSY}}$ High for Write Flash <sup>(3)</sup>	8		14	ms
$t_{XLOL}$	XTAL1 Low to $\overline{\text{OE}}$ Low	67			ns
$t_{OLDV}$	$\overline{\text{OE}}$ Low to DATA Valid		20		ns
$t_{OHDZ}$	$\overline{\text{OE}}$ High to DATA Tri-stated			20	ns

- Notes:
- $t_{WLRH}$  is valid for the Write EEPROM, Write Fuse bits and Write Lock bits commands.
  - $t_{WLRH\_CE}$  is valid for the Chip Erase command.
  - $t_{WLRH\_FLASH}$  is valid for the Write Flash command.

## Serial Downloading

Both the Flash and EEPROM memory arrays can be programmed using the serial SPI bus while  $\overline{\text{RESET}}$  is pulled to GND. The serial interface consists of pins SCK, MOSI (input) and MISO (output). After  $\overline{\text{RESET}}$  is set low, the Programming Enable instruction needs to be executed first, before program/erase operations can be executed.

When programming the EEPROM, an auto-erase cycle is built into the self-timed programming operation (in the Serial mode ONLY) and there is no need to first execute the Chip Erase instruction. The chip erase operation turns the contents of every memory location in both the program and EEPROM arrays into \$FF.

The program and EEPROM memory arrays have separate address spaces:

\$0000 to \$1FFF for Program memory and \$0000 to \$01FF for EEPROM memory.

Either an external system clock is supplied at pin XTAL1 or a crystal needs to be connected across pins XTAL1 and XTAL2. The minimum low and high periods for the serial clock (SCK) input are defined as follows:

Low: > 2 XTAL1 clock cycles

High: > 2 XTAL1 clock cycles

## Serial Programming Algorithm

When writing serial data to the ATmega161, data is clocked on the rising edge of SCK.

When reading data from the ATmega161, data is clocked on the falling edge of SCK. See Figure 80, Figure 81 and Table 49 for timing details.

To program and verify the ATmega161 in the Serial Programming mode, the following sequence is recommended (see 4-byte instruction formats in Table 48):

1. Power-up sequence:

Apply power between  $V_{CC}$  and GND while  $\overline{RESET}$  and SCK are set to "0". If a crystal is not connected across pins XTAL1 and XTAL2, apply a clock signal to the XTAL1 pin. In some systems, the programmer cannot guarantee that SCK is held low during power-up. In this case,  $\overline{RESET}$  must be given a positive pulse of at least two XTAL1 cycles' duration after SCK has been set to "0".

2. Wait for at least 20 ms and enable serial programming by sending the Programming Enable serial instruction to pin MOSI/PB5.
3. The serial programming instructions will not work if the communication is out of synchronization. When in sync, the second byte (\$53) will echo back when issuing the third byte of the Programming Enable instruction. Whether or not the echo is correct, all four bytes of the instruction must be transmitted. If the \$53 did not echo back, give  $\overline{RESET}$  a positive pulse and issue a new Programming Enable command.
4. If a chip erase is performed (must be done to erase the Flash), give  $\overline{RESET}$  a positive pulse and start over from step 2.
5. The Flash is programmed one page at a time. The memory page is loaded one byte at a time by supplying the 6 LSB of the address and data together with the Load Program Memory Page instruction. The Program Memory Page is stored by loading the Write Program Memory Page instruction with the 7 MSB of the address. If polling is not used, the user must wait at least  $t_{WD\_FLASH}$  before issuing the next page (please refer to Table 46). Accessing the serial programming interface before the Flash write operation completes can result in incorrect programming.
6. The EEPROM array is programmed one byte at a time by supplying the address and data together with the appropriate Write instruction. An EEPROM memory location is first automatically erased before new data is written. If polling is not used, the user must wait at least  $t_{WD\_EEPROM}$  before issuing the next byte (please refer to Table 46). In a chip-erased device, no \$FFs in the data file(s) need to be programmed.
7. Any memory location can be verified by using the Read instruction, which returns the content at the selected address at serial output MISO/PB6.
8. At the end of the programming session,  $\overline{RESET}$  can be set high to commence normal operation.
9. Power-off sequence (if needed):
  - Set XTAL1 to "0" (if a crystal is not used).
  - Set  $\overline{RESET}$  to "1".
  - Turn  $V_{CC}$  power off.

## Data Polling Flash

When a page is being programmed into the Flash, reading an address location within the page being programmed will give the value \$FF. At the time the device is ready for a new page, the programmed value will read correctly. This is used to determine when the next page can be written. Note that the entire page is written simultaneously and any address within the page can be used for polling. Data polling of the FLASH will not work for the value \$FF, so when programming this value, the user will have to wait for at least

$t_{WD\_FLASH}$  before programming the next page. As a chip-erased device contains \$FF in all locations, programming of addresses that are meant to contain \$FF can be skipped. See Table 46 for  $t_{WD\_FLASH}$  value.

## Data Polling EEPROM

When a new byte has been written and is being programmed into EEPROM, reading the address location being programmed will give the value \$FF. At the time the device is ready for a new byte, the programmed value will read correctly. This is used to determine when the next byte can be written. This will not work for the value \$FF, but the user should keep the following in mind: As a chip-erased device contains \$FF in all locations, programming of addresses that are meant to contain \$FF can be skipped. This does not apply if the EEPROM is reprogrammed without chip-erasing the device. In this case, data polling cannot be used for the value \$FF, and the user will have to wait at least  $t_{WD\_EEPROM}$  before programming the next byte. See Table 46 for  $t_{WD\_EEPROM}$  value.

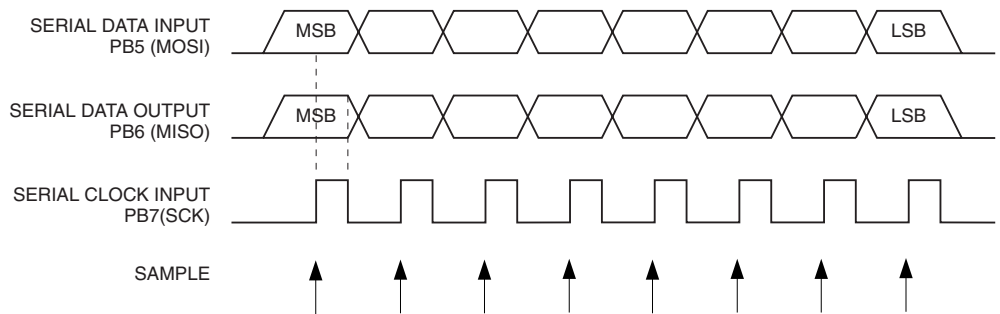
**Table 46.** Minimum Wait Delay before Writing the Next Flash or EEPROM Location

Symbol	Minimum Wait Delay
$t_{WD\_FLASH}$	14 ms
$t_{WD\_EEPROM}$	3.4 ms

**Table 47.** Minimum Wait Delay after a Chip Erase Command

Symbol	Minimum Wait Delay
$t_{WD\_ERASE}$	28 ms

**Figure 80.** Serial Programming Waveforms



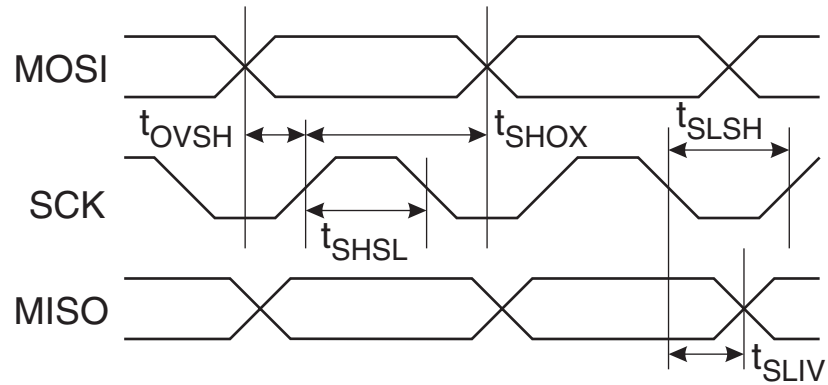
**Table 48. Serial Programming Instruction Set<sup>(1)</sup>**

Instruction	Instruction Format				Operation
	Byte 1	Byte 2	Byte 3	Byte 4	
Programming Enable	1010 1100	0101 0011	xxxx xxxx	xxxx xxxx	Enable Serial Programming after RESET goes low.
Chip Erase	1010 1100	100x xxxx	xxxx xxxx	xxxx xxxx	Chip Erase EEPROM and Flash.
Read Program Memory	0010 H000	xxxxa aaaa	bbbb bbbb	oooo oooo	Read H (high or low) data o from Program memory at word address a:b.
Load Program Memory Page	0100 H000	xxxx xxxx	xxbb bbbb	iiii iiii	Write H (high or low) data i to Program memory page at word address b.
Write Program Memory Page	0100 1100	xxxxa aaaa	bbxx xxxx	iiii iiii	Write Program memory page at address a:b.
Read EEPROM Memory	1010 0000	xxxx xxxx	bbbb bbbb	oooo oooo	Read data o from EEPROM memory at address a:b.
Write EEPROM Memory	1100 0000	xxxx xxxx	bbbb bbbb	iiii iiii	Write data i to EEPROM memory at address a:b.
Read Lock bits	0101 1000	xxxx xxxx	xxxx xxxx	xx65 4321	Read Lock bits. "0" = programmed, "1" = unprogrammed.
Write Lock bits	1010 1100	111x xxxx	xxxx xxxx	1165 4321	Write Lock bits. Set bits 6 - 1 = "0" to program Lock bits.
Read Signature Byte	0011 0000	xxxx xxxx	xxxx xxbb	oooo oooo	Read Signature byte o at address b.
Write Fuse bits	1010 1100	101x xxxx	xxxx xxxx	1D1B 1987	Set bits D - B, 9 - 7 = "0" to program, "1" to unprogram
Read Fuse bits	0101 0000	xxxx xxxx	xxxx xxxx	xDCB 1987	Read Fuse bits. "0" = programmed, "1" = unprogrammed

Note: 1. a = address high bits  
b = address low bits  
H = 0 – Low byte, 1 – High Byte  
o = data out  
i = data in  
x = don't care  
1 = lock bit 1  
2 = lock bit 2  
3 = Boot Lock Bit1  
4 = Boot Lock Bit2  
5 = Boot Lock Bit11  
6 = Boot Lock Bit12  
7 = CKSEL0 Fuse  
8 = CKSEL1 Fuse  
9 = CKSEL2 Fuse  
B = SUT Fuse  
C = SPIEN Fuse  
D = BOOTRST Fuse

## Serial Programming Characteristics

**Figure 81.** Serial Programming Timing



**Table 49.** Serial Programming Characteristics,  $T_A = -40^{\circ}\text{C}$  to  $85^{\circ}\text{C}$ ,  $V_{CC} = 2.7 - 5.5\text{V}$  (unless otherwise noted)

Symbol	Parameter		Min	Typ	Max	Units
$1/t_{CLCL}$	Oscillator Frequency	$(V_{CC} = 2.7 - 5.5\text{V})$	0		4	MHz
		$(V_{CC} = 4.0 - 5.5\text{V})$	0		8	MHz
$t_{CLCL}$	Oscillator Period	$(V_{CC} = 2.7 - 5.5\text{V})$	250			ns
		$(V_{CC} = 4.0 - 5.5\text{V})$	125			ns
$t_{SHSL}$	SCK Pulse Width High		$2 t_{CLCL}$			ns
$t_{SLSH}$	SCK Pulse Width Low		$2 t_{CLCL}$			ns
$t_{OVSH}$	MOSI Setup to SCK High		$t_{CLCL}$			ns
$t_{SHOX}$	MOSI Hold after SCK High		$2 t_{CLCL}$			ns
$t_{SLIV}$	SCK Low to MISO Valid		10	16	32	ns

## Electrical Characteristics

### Absolute Maximum Ratings\*

Operating Temperature .....	-55°C to +125°C
Storage Temperature .....	-65°C to +150°C
Voltage on Any Pin except $\overline{\text{RESET}}$ with Respect to Ground .....	-1.0V to $V_{CC} + 0.5V$
Voltage on $\overline{\text{RESET}}$ with Respect to Ground .....	-1.0V to +13.0V
Maximum Operating Voltage .....	6.6V
DC Current per I/O Pin .....	40.0 mA
DC Current VCC and GND Pins .....	200.0 mA

\*NOTICE: Stresses beyond those listed under “Absolute Maximum Ratings” may cause permanent damage to the device. This is a stress rating only and functional operation of the device at these or other conditions beyond those indicated in the operational sections of this specification is not implied. Exposure to absolute maximum rating conditions for extended periods may affect device reliability.

## DC Characteristics

$T_A = -40^{\circ}\text{C}$  to  $85^{\circ}\text{C}$ ,  $V_{CC} = 2.7\text{V}$  to  $5.5\text{V}$  (unless otherwise noted)<sup>(1)(2)(3)(4)(5)</sup>

Symbol	Parameter	Condition	Min	Typ	Max	Units	
$V_{IL}$	Input Low Voltage	(Except XTAL1)	-0.5		$0.3 V_{CC}^{(1)}$	V	
$V_{IL1}$	Input Low Voltage	(XTAL1)	-0.5		$0.2 V_{CC}^{(1)}$	V	
$V_{IH}$	Input High Voltage	(Except XTAL1, $\overline{\text{RESET}}$ )	$0.6 V_{CC}^{(2)}$		$V_{CC} + 0.5$	V	
$V_{IH1}$	Input High Voltage	(XTAL1)	$0.8 V_{CC}^{(2)}$		$V_{CC} + 0.5$	V	
$V_{IH2}$	Input High Voltage	( $\overline{\text{RESET}}$ )	$0.9 V_{CC}^{(2)}$		$V_{CC} + 0.5$	V	
$V_{OL}$	Output Low Voltage <sup>(3)</sup> (Ports A,B,C,D)	$I_{OL} = 20\text{ mA}$ , $V_{CC} = 5\text{V}$			0.6	V	
		$I_{OL} = 10\text{ mA}$ , $V_{CC} = 3\text{V}$			0.5	V	
$V_{OH}$	Output High Voltage <sup>(4)</sup> (Ports A,B,C,D)	$I_{OH} = -3\text{ mA}$ , $V_{CC} = 5\text{V}$	4.2			V	
		$I_{OH} = -1.5\text{ mA}$ , $V_{CC} = 3\text{V}$	2.3			V	
$I_{IL}$	Input Leakage Current I/O pin	$V_{CC} = 5.5\text{V}$ , pin low (absolute value)			8.0	$\mu\text{A}$	
$I_{IH}$	Input Leakage Current I/O pin	$V_{CC} = 5.5\text{V}$ , pin high (absolute value)			980	nA	
RRST	Reset Pull-up Resistor		100		500	$\text{k}\Omega$	
$R_{I/O}$	I/O Pin Pull-up Resistor		35		120	$\text{k}\Omega$	
$I_{CC}$	Power Supply Current	Active mode, $V_{CC} = 3\text{V}$ , 4 MHz			3.0	mA	
		Idle mode $V_{CC} = 3\text{V}$ , 4 MHz			1.2	mA	
	Power-down mode <sup>(5)</sup>	WDT enabled, $V_{CC} = 3\text{V}$		9		15.0	$\mu\text{A}$
		WDT disabled, $V_{CC} = 3\text{V}$		<1		2.0	$\mu\text{A}$
$V_{ACIO}$	Analog Comparator Input Offset Voltage	$V_{CC} = 5\text{V}$ $V_{in} = V_{CC}/2$			40	mV	
$I_{ACLK}$	Analog Comparator Input Leakage Current	$V_{CC} = 5\text{V}$ $V_{in} = V_{CC}/2$	-50		50	nA	
$t_{ACPD}$	Analog Comparator Propagation Delay	$V_{CC} = 2.7\text{V}$		750		ns	
		$V_{CC} = 4.0\text{V}$		500			

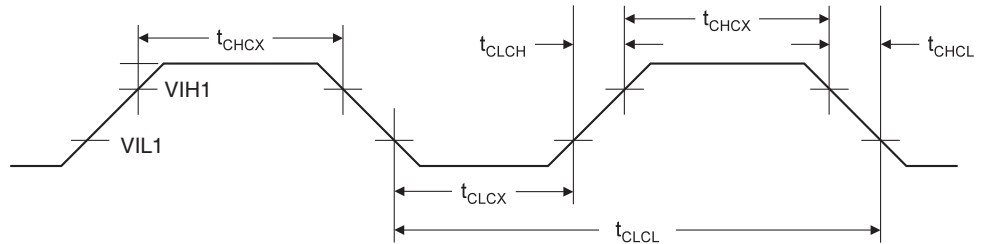
- Notes:
1. "Max" means the highest value where the pin is guaranteed to be read as low.
  2. "Min" means the lowest value where the pin is guaranteed to be read as high.
  3. Although each I/O port can sink more than the test conditions (20 mA at  $V_{CC} = 5\text{V}$ , 10 mA at  $V_{CC} = 3\text{V}$ ) under steady-state conditions (non-transient), the following must be observed:
    - 1] The sum of all  $I_{OL}$ , for all ports, should not exceed 200 mA.
    - 2] The sum of all  $I_{OL}$ , for ports B0 - B7, D0 - D7 and XTAL2, should not exceed 100 mA.
    - 3] The sum of all  $I_{OL}$ , for ports A0 - A7, ALE, OC1B and C0 - C7 should not exceed 100 mA.
 If  $I_{OL}$  exceeds the test condition,  $V_{OL}$  may exceed the related specification. Pins are not guaranteed to sink current greater than the listed test condition.
  4. Although each I/O port can source more than the test conditions (3 mA at  $V_{CC} = 5\text{V}$ , 1.5 mA at  $V_{CC} = 3\text{V}$ ) under steady-state conditions (non-transient), the following must be observed:
    - 1] The sum of all  $I_{OH}$ , for all ports, should not exceed 200 mA.
    - 2] The sum of all  $I_{OH}$ , for ports B0 - B7, D0 - D7 and XTAL2, should not exceed 100 mA.
    - 3] The sum of all  $I_{OH}$ , for ports A0 - A7, ALE, OC1B and C0 - C7 should not exceed 100 mA.

If  $I_{OH}$  exceeds the test condition,  $V_{OH}$  may exceed the related specification. Pins are not guaranteed to source current greater than the listed test condition.

5. Minimum  $V_{CC}$  for power-down is 2V.

## External Clock Drive Waveforms

**Figure 82.** External Clock



**Table 50.** External Clock Drive<sup>(1)</sup>

Symbol	Parameter	$V_{CC} = 2.7V \text{ to } 5.5V$		$V_{CC} = 4.0V \text{ to } 5.5V$		Units
		Min	Max	Min	Max	
$1/t_{CLCL}$	Oscillator Frequency	0	4	0	8	MHz
$t_{CLCL}$	Clock Period	250		125		ns
$t_{CHCX}$	High Time	100		50		ns
$t_{CLCX}$	Low Time	100		50		ns
$t_{CLCH}$	Rise Time		1.6		0.5	$\mu s$
$t_{CHCL}$	Fall Time		1.6		0.5	$\mu s$

Notes: 1. See “External Data Memory Timing” for a description of how the duty cycle influences the timing for the external Data memory.

## External Data Memory Timing

**Table 51.** External Data Memory Characteristics, 4.0 - 5.5 Volts, No Wait State

	Symbol	Parameter	8 MHz Oscillator		Variable Oscillator		Unit
			Min	Max	Min	Max	
0	$1/t_{CLCL}$	Oscillator Frequency			0.0	8.0	MHz
1	$t_{LHLL}$	ALE Pulse Width	95		$1.0t_{CLCL}-30$		ns
2	$t_{AVLL}$	Address Valid A to ALE Low	22.5		$0.5t_{CLCL}-40^{(1)}$		ns
3a	$t_{LLAX\_ST}$	Address Hold After ALE Low, write access	10		10		ns
3b	$t_{LLAX\_LD}$	Address Hold after ALE Low, read access	15		15		ns
4	$t_{AVLLC}$	Address Valid C to ALE Low	22.5		$0.5t_{CLCL}-40^{(1)}$		ns
5	$t_{AVRL}$	Address Valid to RD Low	95		$1.0t_{CLCL}-30$		ns
6	$t_{AVWL}$	Address Valid to WR Low	95		$1.0t_{CLCL}-30$		ns
7	$t_{LLWL}$	ALE Low to WR Low	42.5	145	$0.5t_{CLCL}-20^{(2)}$	$0.5t_{CLCL}+20^{(2)}$	ns
8	$t_{LLRL}$	ALE Low to RD Low	42.5	145	$0.5t_{CLCL}-20^{(2)}$	$0.5t_{CLCL}+20^{(2)}$	ns
9	$t_{DVRH}$	Data Setup to RD High	60		60		ns
10	$t_{RLDV}$	Read Low to Data Valid		65		65	ns
11	$t_{RHDX}$	Data Hold After RD High	0		0		ns
12	$t_{RLRH}$	RD Pulse Width	105		$1.0t_{CLCL}-20$		ns
13	$t_{DVWL}$	Data Setup to WR Low	27.5		$0.5t_{CLCL}-35^{(1)}$		ns
14	$t_{WHDX}$	Data Hold After WR High	27.5		$0.5t_{CLCL}-35^{(1)}$		ns
15	$t_{DVWH}$	Data Valid to WR High	95		$1.0t_{CLCL}-30$		ns
16	$t_{WLWH}$	WR Pulse Width	105		$1.0t_{CLCL}-20$		ns

- Notes: 1. This assumes 50% clock duty cycle. The half period is actually the high time of the external clock, XTAL1.  
 2. This assumes 50% clock duty cycle. The half period is actually the low time of the external clock, XTAL1.

**Table 52.** External Data Memory Characteristics, 4.0 - 5.5 Volts, 1 Cycle Wait State

	Symbol	Parameter	8 MHz Oscillator		Variable Oscillator		Unit
			Min	Max	Min	Max	
0	$1/t_{CLCL}$	Oscillator Frequency			0.0	8.0	MHz
10	$t_{RLDV}$	Read Low to Data Valid		185		$2.0t_{CLCL}-65$	ns
12	$t_{RLRH}$	RD Pulse Width	230		$2.0t_{CLCL}-20$		ns
15	$t_{DVWH}$	Data Valid to WR High	220		$2.0t_{CLCL}-30$		ns
16	$t_{WLWH}$	WR Pulse Width	230		$2.0t_{CLCL}-20$		ns

**Table 53.** External Data Memory Characteristics, 4.0 - 5.5 Volts, SRWn1 = 1, SRWn0 = 0

	Symbol	Parameter	8 MHz Oscillator		Variable Oscillator		Unit
			Min	Max	Min	Max	
0	$1/t_{CLCL}$	Oscillator Frequency			0.0	8.0	MHz
10	$t_{RLDV}$	Read Low to Data Valid		310		$3.0t_{CLCL}-65$	ns
12	$t_{RLRH}$	RD Pulse Width	355		$3.0t_{CLCL}-20$		ns
15	$t_{DVWH}$	Data Valid to WR High	345		$3.0t_{CLCL}-30$		ns
16	$t_{WLWH}$	WR Pulse Width	35		$3.0t_{CLCL}-20$		ns

**Table 54.** External Data Memory Characteristics, 4.0 - 5.5 Volts, SRWn1 = 1, SRWn0 = 1

	Symbol	Parameter	8 MHz Oscillator		Variable Oscillator		Unit
			Min	Max	Min	Max	
0	$1/t_{CLCL}$	Oscillator Frequency			0.0	8.0	MHz
10	$t_{RLDV}$	Read Low to Data Valid		310		$3.0t_{CLCL}-65$	ns
12	$t_{RLRH}$	RD Pulse Width	355		$3.0t_{CLCL}-20$		ns
14	$t_{WHDX}$	Data Hold After WR High	152.5		$1.5t_{CLCL}-35$		ns
15	$t_{DVWH}$	Data Valid to WR High	345		$3.0t_{CLCL}-30$		ns
16	$t_{WLWH}$	WR Pulse Width	355		$3.0t_{CLCL}-20$		ns

**Table 55.** External Data Memory Characteristics, 2.7 - 5.5 Volts, No Wait State

	Symbol	Parameter	4 MHz Oscillator		Variable Oscillator		Unit
			Min	Max	Min	Max	
0	$1/t_{CLCL}$	Oscillator Frequency			0.0	4.0	MHz
1	$t_{LHLL}$	ALE Pulse Width	195		$t_{CLCL}-55$		ns
2	$t_{AVLL}$	Address Valid A to ALE Low	60		$0.5t_{CLCL}-65$		ns
3a	$t_{LLAX\_ST}$	Address Hold After ALE Low, write access	10		10		ns
3b	$t_{LLAX\_LD}$	Address Hold after ALE Low, read access	15		15		ns
4	$t_{AVLLC}$	Address Valid C to ALE Low	60		$0.5t_{CLCL}-65$		ns
5	$t_{AVRL}$	Address Valid to RD Low	200		$1.0t_{CLCL}-50$		ns
6	$t_{AVWL}$	Address Valid to WR Low	200		$1.0t_{CLCL}-50$		ns
7	$t_{LLWL}$	ALE Low to WR Low	105	145	$0.5t_{CLCL}-20$	$0.5t_{CLCL}+20$	ns
8	$t_{LLRL}$	ALE Low to RD Low	105	145	$0.5t_{CLCL}-20$	$0.5t_{CLCL}+20$	ns
9	$t_{DVRH}$	Data Setup to RD High	95		95		ns
10	$t_{RLDV}$	Read Low to Data Valid		165		165	ns
11	$t_{RHDX}$	Data Hold After RD High	0		0		ns

**Table 55.** External Data Memory Characteristics, 2.7 - 5.5 Volts, No Wait State (Continued)

	Symbol	Parameter	4 MHz Oscillator		Variable Oscillator		Unit
			Min	Max	Min	Max	
12	$t_{RLRH}$	RD Pulse Width	230		$1.0t_{CLCL}-20$		ns
13	$t_{DVWL}$	Data Setup to WR Low	70		$0.5t_{CLCL}-55$		ns
14	$t_{WHDX}$	Data Hold After WR High	125		$0.5t_{CLCL}-0$		ns
15	$t_{DVWH}$	Data Valid to WR High	210		$1.0t_{CLCL}-40$		ns
16	$t_{WLWH}$	WR Pulse Width	230		$1.0t_{CLCL}-20$		ns

Notes: 1. This assumes 50% clock duty cycle. The half period is actually the high time of the external clock, XTAL1.  
 2. This assumes 50% clock duty cycle. The half period is actually the low time of the external clock, XTAL1.

**Table 56.** External Data Memory Characteristics, 2.7 - 5.5 Volts, SRWn1 = 0, SRWn0 = 1

	Symbol	Parameter	4 MHz Oscillator		Variable Oscillator		Unit
			Min	Max	Min	Max	
0	$1/t_{CLCL}$	Oscillator Frequency			0.0	4.0	MHz
10	$t_{RLDV}$	Read Low to Data Valid		335		$2.0t_{CLCL}-165$	ns
12	$t_{RLRH}$	RD Pulse Width	480		$2.0t_{CLCL}-20$		ns
15	$t_{DVWH}$	Data Valid to WR High	460		$2.0t_{CLCL}-40$		ns
16	$t_{WLWH}$	WR Pulse Width	480		$2.0t_{CLCL}-20$		ns

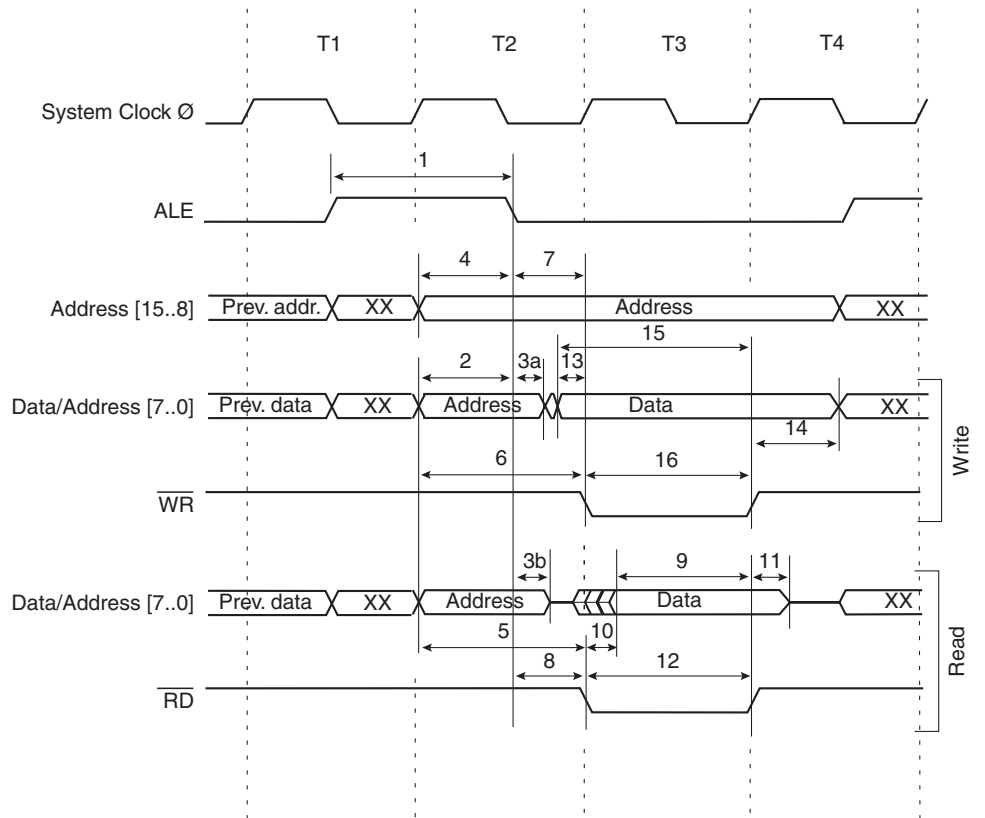
**Table 57.** External Data Memory Characteristics, 2.7 - 5.5 Volts, SRWn1 = 1, SRWn0 = 0

	Symbol	Parameter	4 MHz Oscillator		Variable Oscillator		Unit
			Min	Max	Min	Max	
0	$1/t_{CLCL}$	Oscillator Frequency			0.0	4.0	MHz
10	$t_{RLDV}$	Read Low to Data Valid		585		$3.0t_{CLCL}-165$	ns
12	$t_{RLRH}$	RD Pulse Width	730		$3.0t_{CLCL}-20$		ns
15	$t_{DVWH}$	Data Valid to WR High	710		$3.0t_{CLCL}-40$		ns
16	$t_{WLWH}$	WR Pulse Width	730		$3.0t_{CLCL}-20$		ns

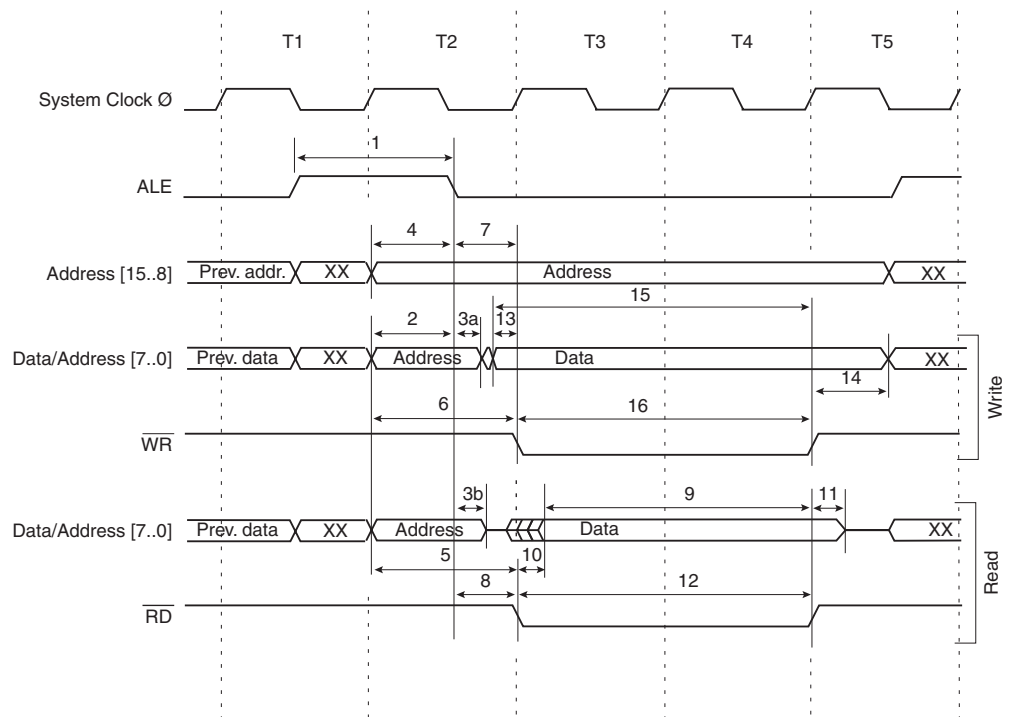
**Table 58.** External Data Memory Characteristics, 2.7 - 5.5 Volts, SRWn1 = 1, SRWn0 = 1

	Symbol	Parameter	4 MHz Oscillator		Variable Oscillator		Unit
			Min	Max	Min	Max	
0	$1/t_{CLCL}$	Oscillator Frequency			0.0	4.0	MHz
10	$t_{RLDV}$	Read Low to Data Valid		585		$3.0t_{CLCL}-165$	ns
12	$t_{RLRH}$	RD Pulse Width	730		$3.0t_{CLCL}-20$		ns
14	$t_{WHDX}$	Data Hold After WR High	375		$1.5t_{CLCL}-0$		ns
15	$t_{DVWH}$	Data Valid to WR High	710		$3.0t_{CLCL}-40$		ns
16	$t_{WLWH}$	WR Pulse Width	730		$3.0t_{CLCL}-20$		ns

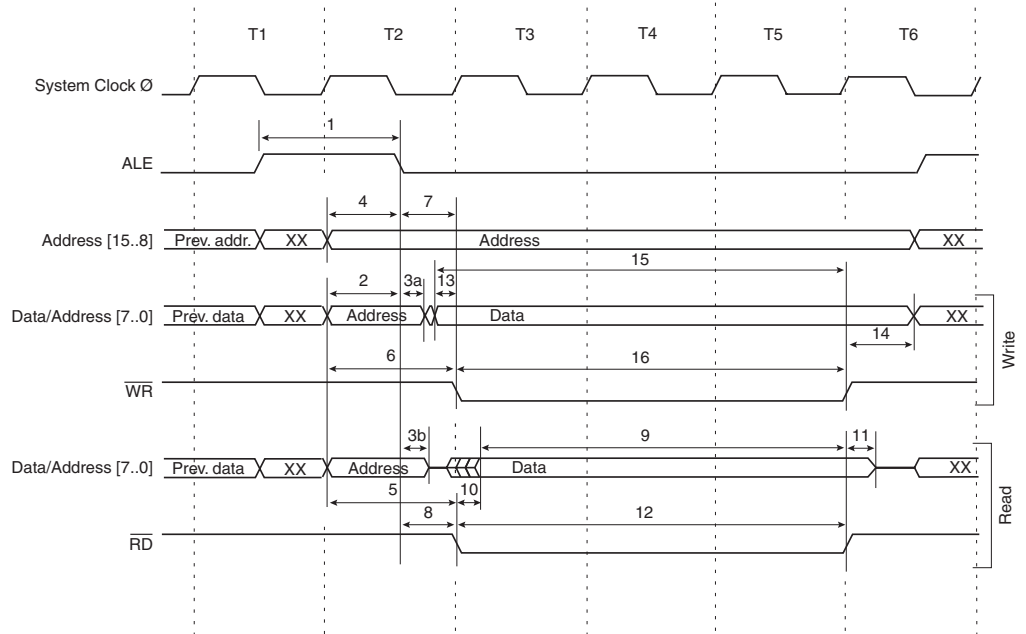
**Figure 83.** External Memory Timing (SRWn1 = 0, SRWn0 = 0)



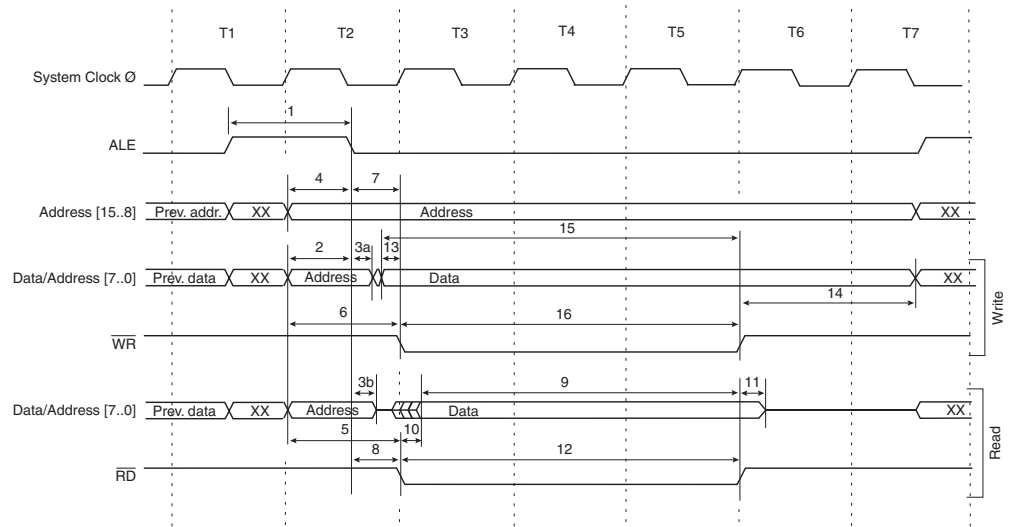
**Figure 84.** External Memory Timing (SRWn1 = 0, SRWn0 = 1)



**Figure 85. External Memory Timing (SRWn1 = 1, SRWn0 = 0)**



**Figure 86. External Memory Timing (SRWn1 = 1, SRWn0 = 1)<sup>(1)</sup>**

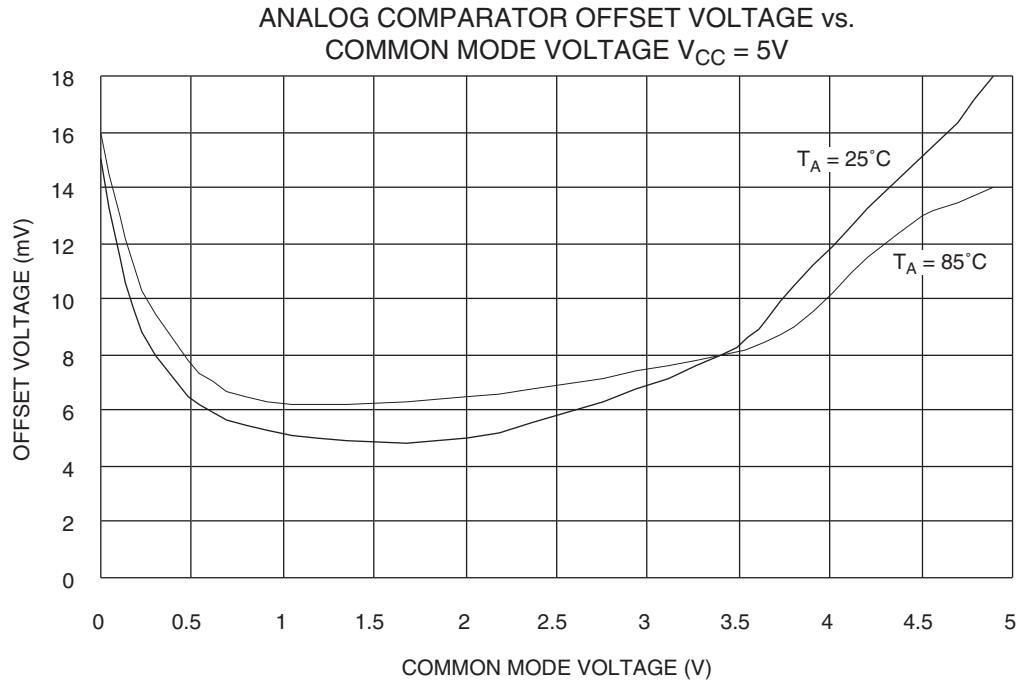


Note: 1. The ALE pulse in the last period (T4 - T7) is only present if the next instruction accesses the RAM (internal or external). The data and address will only change in T4 - T7 if ALE is present (the next instruction accesses the RAM).

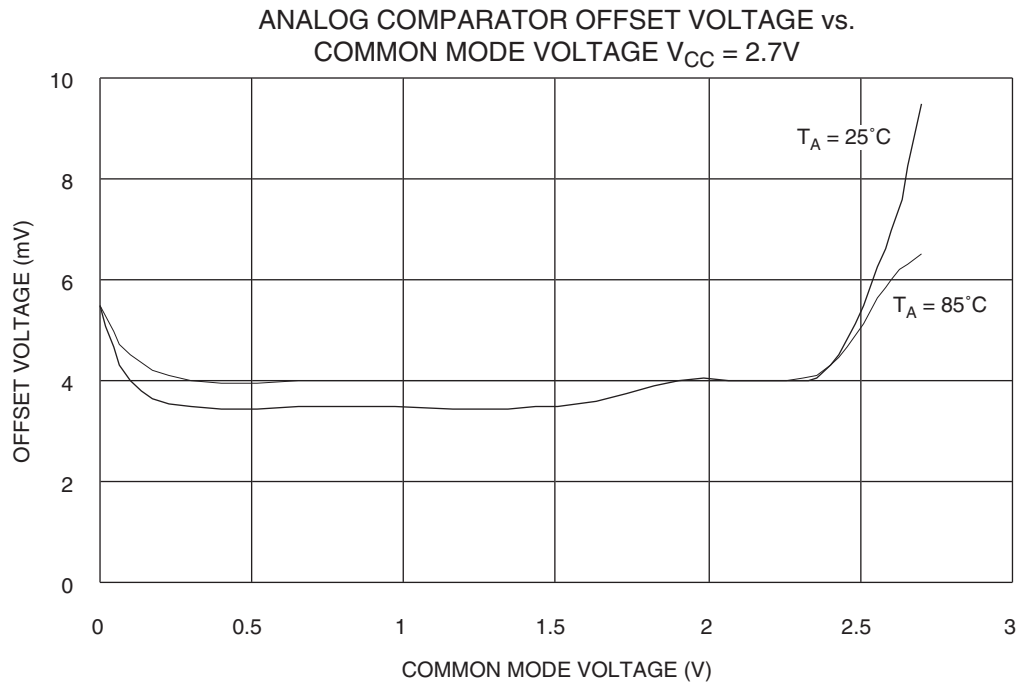
## Typical Characteristics

Analog Comparator offset voltage is measured as absolute offset.

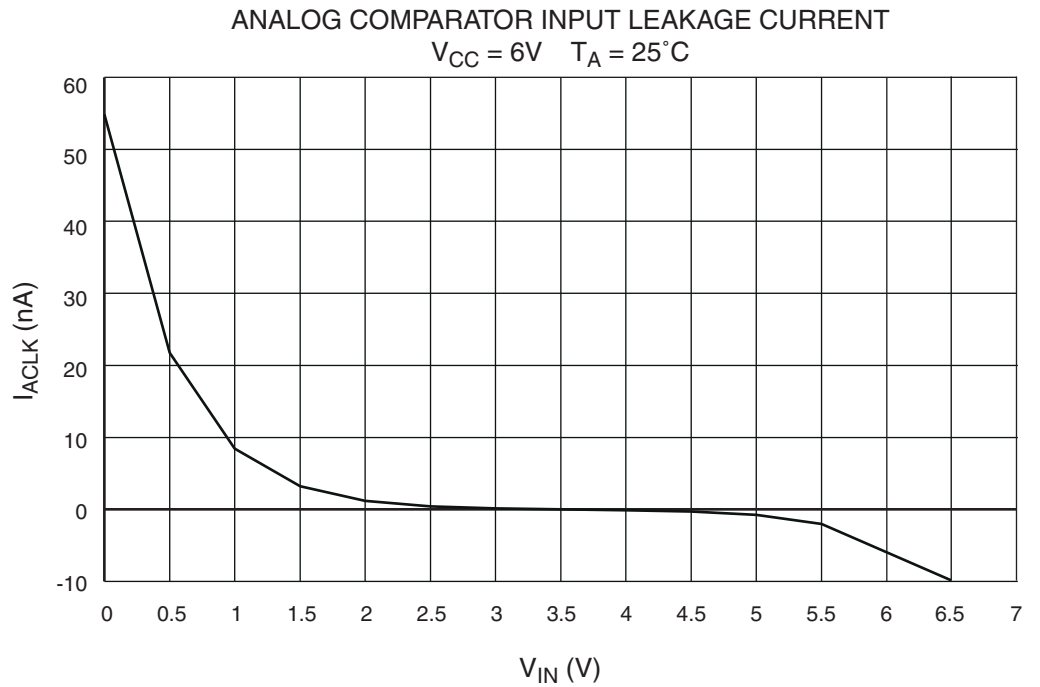
**Figure 87.** Analog Comparator Offset Voltage vs. Common Mode Voltage



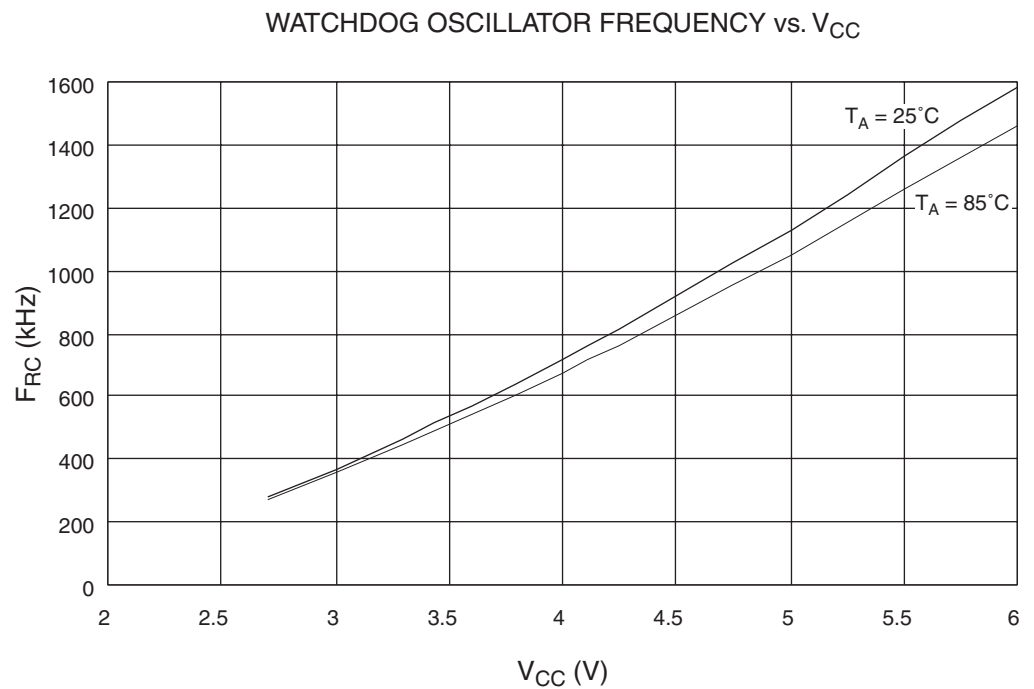
**Figure 88.** Analog Comparator Offset Voltage vs. Common Mode Voltage



**Figure 89.** Analog Comparator Input Leakage Current

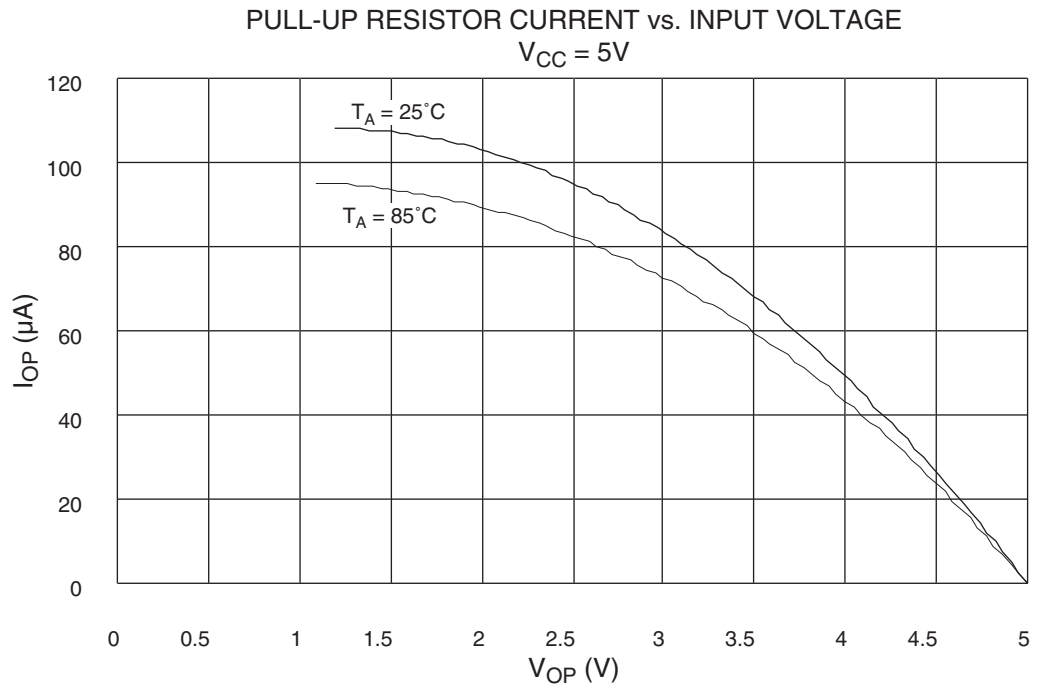


**Figure 90.** Watchdog Oscillator Frequency vs.  $V_{CC}$

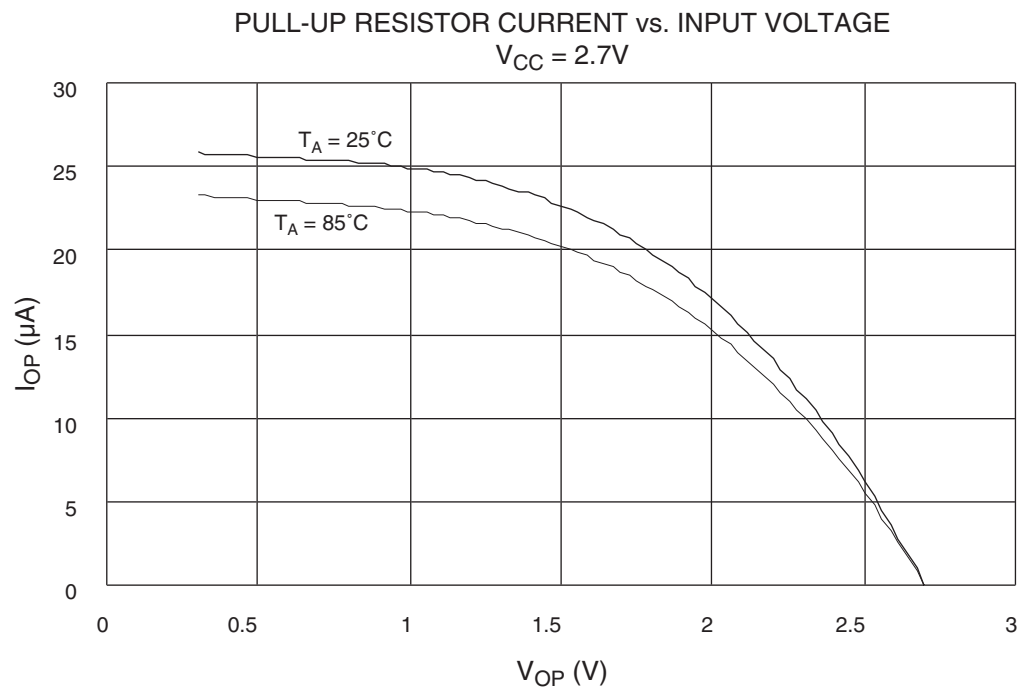


Sink and source capabilities of I/O ports are measured on one pin at a time.

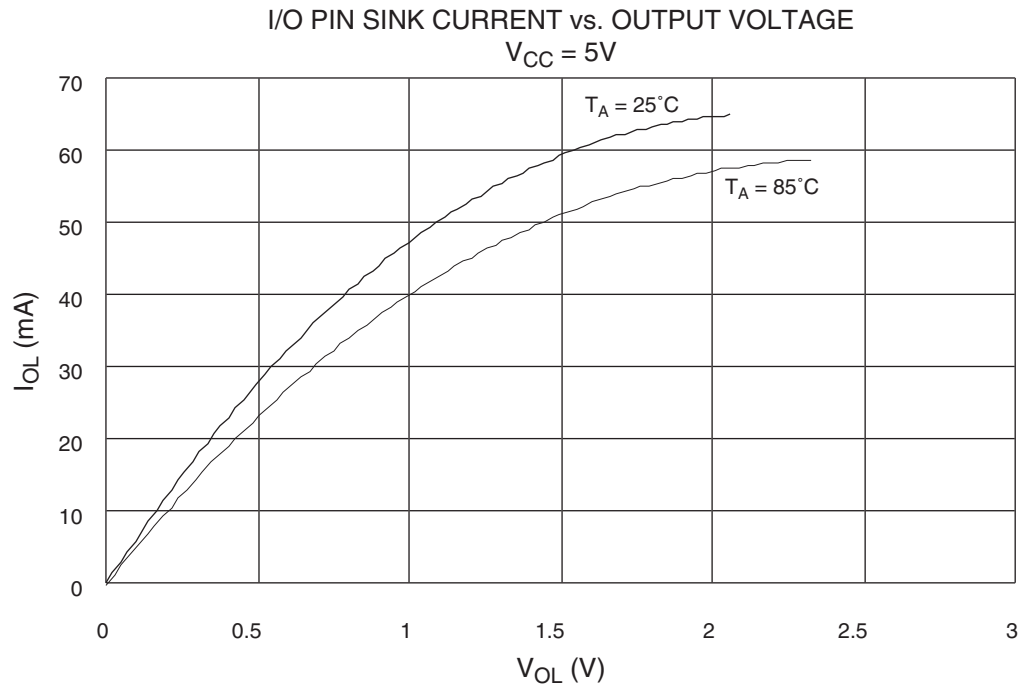
**Figure 91.** Pull-up Resistor Current vs. Input Voltage



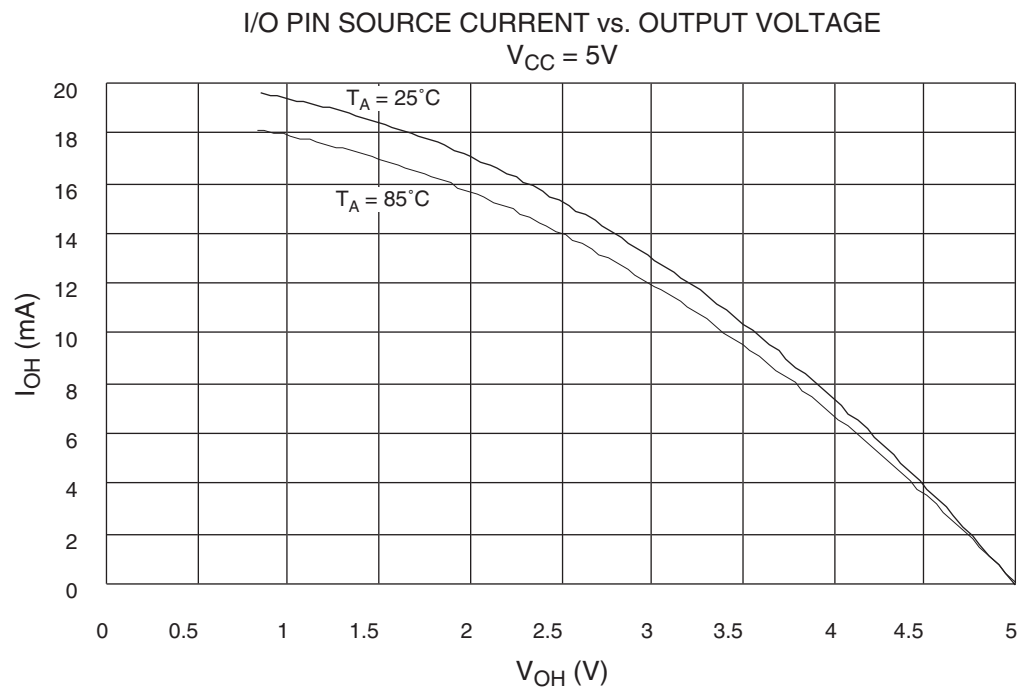
**Figure 92.** Pull-up Resistor Current vs. Input Voltage



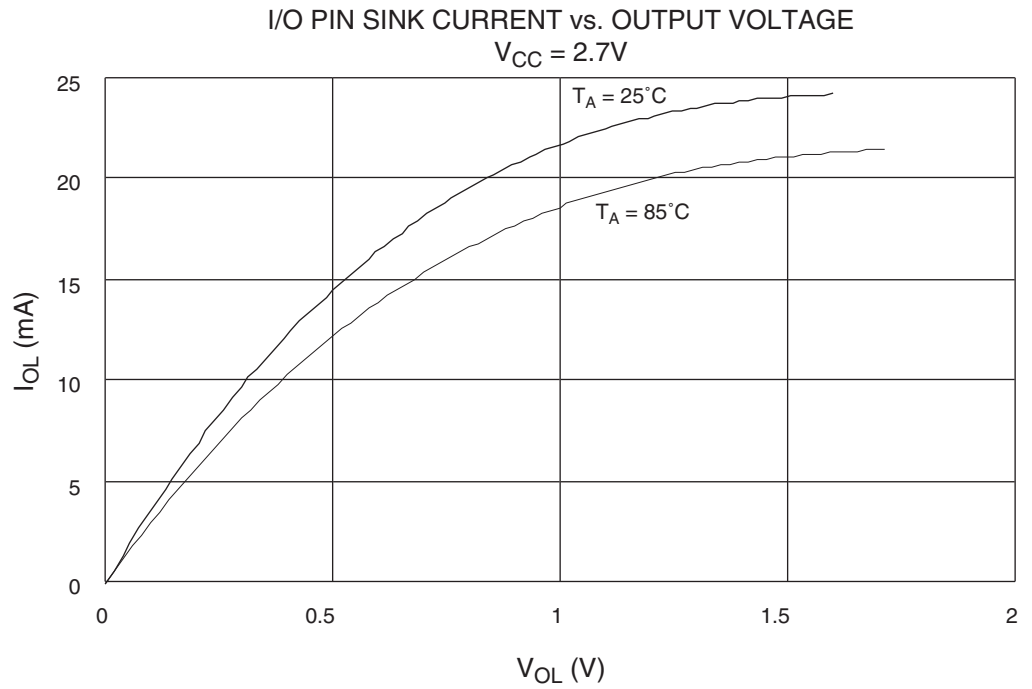
**Figure 93.** I/O Pin Sink Current vs. Output Voltage



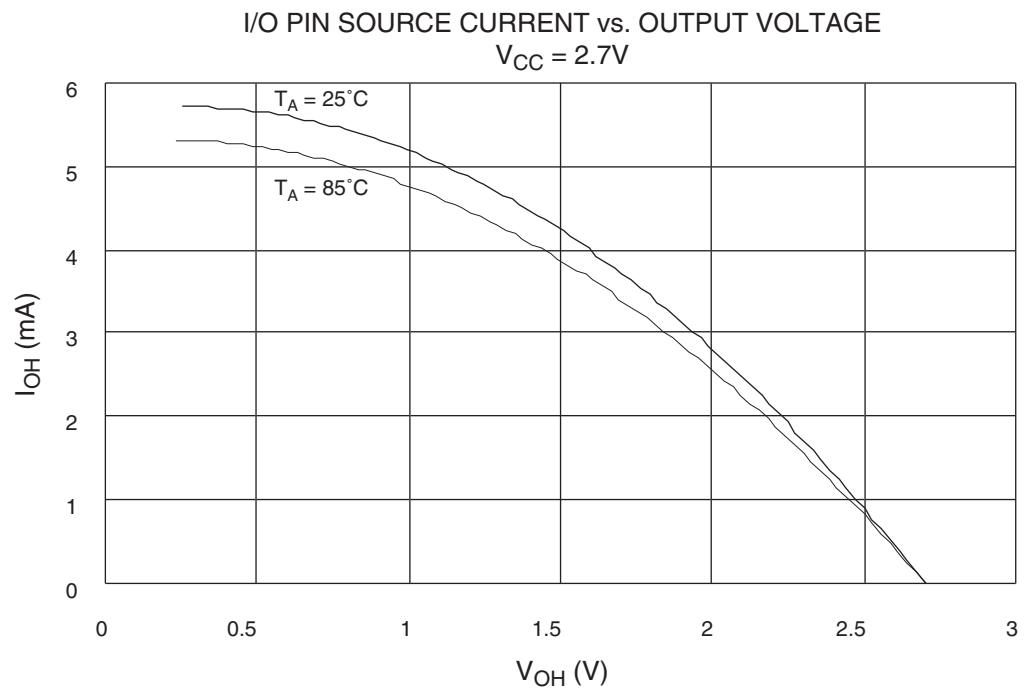
**Figure 94.** I/O Pin Source Current vs. Output Voltage



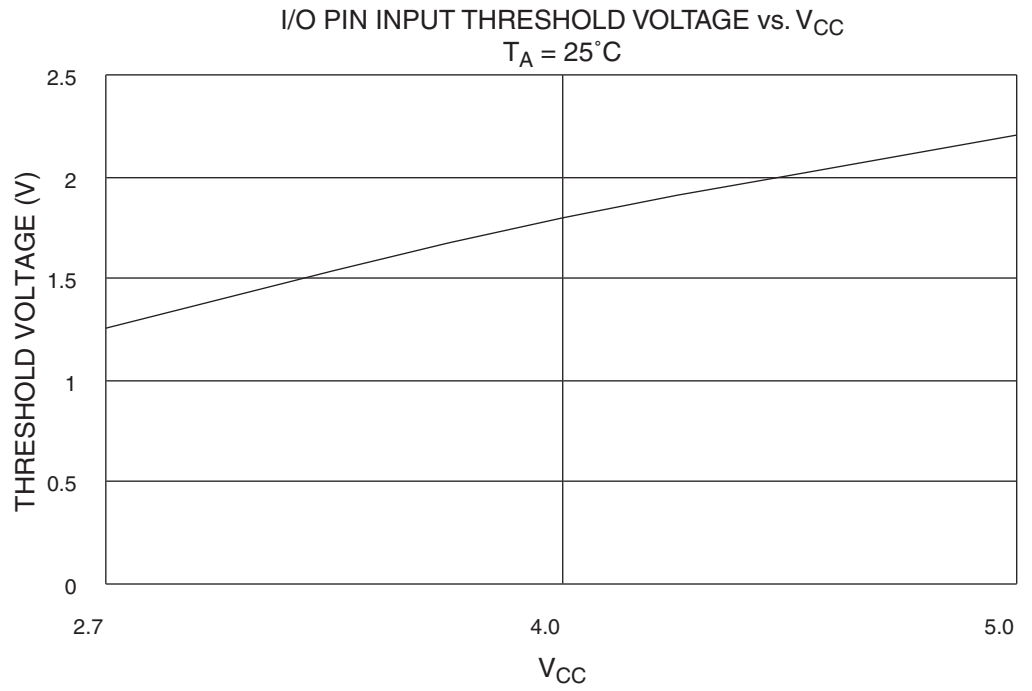
**Figure 95.** I/O Pin Sink Current vs. Output Voltage



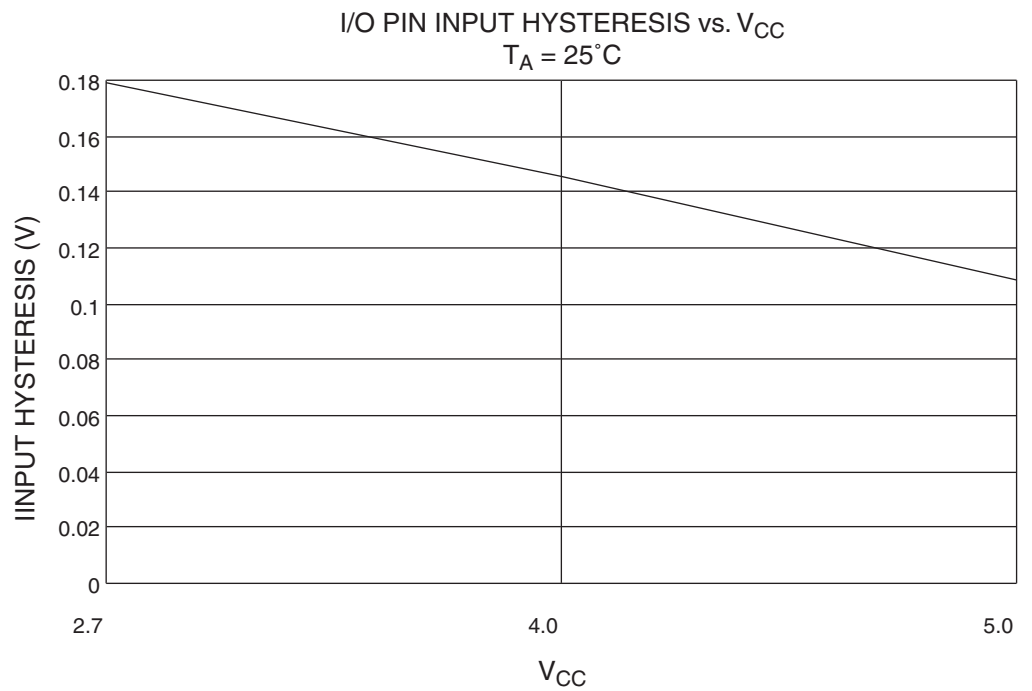
**Figure 96.** I/O Pin Source Current vs. Output Voltage



**Figure 97.** I/O Pin Input Threshold vs.  $V_{CC}$



**Figure 98.** I/O Pin Input Hysteresis vs.  $V_{CC}$





# Register Summary

Address	Name	Bit 7	Bit 6	Bit 5	Bit 4	Bit 3	Bit 2	Bit 1	Bit 0	Page
\$3F (\$5F)	SREG	I	T	H	S	V	N	Z	C	page 21
\$3E (\$5E)	SPH	SP15	SP14	SP13	SP12	SP11	SP10	SP9	SP8	page 22
\$3D (\$5D)	SPL	SP7	SP6	SP5	SP4	SP3	SP2	SP1	SP0	page 22
\$3C (\$5C)	Reserved									
\$3B (\$5B)	GIMSK	INT1	INT0	INT2	-	-	-	-	-	page 30
\$3A (\$5A)	GIFR	INTF1	INTF0	INTF2						page 31
\$39 (\$59)	TIMSK	TOIE1	OCIE1A	OCIE1B	TOIE2	TICIE1	OCIE2	TOIE0	OCIE0	page 31
\$38 (\$58)	TIFR	TOV1	OCF1A	OCF1B	TOV2	ICF1	OCF2	TOV0	OCIF0	page 33
\$37 (\$57)	SPMCR	-	-	-	-	LBSET	PGWRT	PGERS	SPMEN	page 114
\$36 (\$56)	EMUCR	SM0	SRL2	SRL1	SRL0	SRW01	SRW00	SRW11	ISC2	page 36
\$35 (\$55)	MCUCR	SRE	SRW10	SE	SM1	ISC11	ISC10	ISC01	ISC00	page 34
\$34 (\$54)	MCUSR	-	-	-	-	WDRF	BORF	EXTRF	PORF	page 29
\$33 (\$53)	TCCR0	FOC0	PWM0	COM01	COM00	CTC0	CS02	CS01	CS00	page 42
\$32 (\$52)	TCNT0	Timer/Counter0 Counter Register								page 44
\$31 (\$51)	OCR0	Timer/Counter0 Output Compare Register								page 44
\$30 (\$50)	SFIOR	-	-	-	-	-	-	PSR2	PSR10	page 39
\$2F (\$4F)	TCCR1A	COM1A1	COM1A0	COM1B1	COM1B0	FOC1A	FOC1B	PWM11	PWM10	page 50
\$2E (\$4E)	TCCR1B	ICNC1	ICES1	-	-	CTC1	CS12	CS11	CS10	page 52
\$2D (\$4D)	TCNT1H	Timer/Counter1 - Counter Register High Byte								page 53
\$2C (\$4C)	TCNT1L	Timer/Counter1 - Counter Register Low Byte								page 53
\$2B (\$4B)	OCR1AH	Timer/Counter1 - Output Compare Register A High Byte								page 54
\$2A (\$4A)	OCR1AL	Timer/Counter1 - Output Compare Register A Low Byte								page 54
\$29 (\$49)	OCR1BH	Timer/Counter1 - Output Compare Register B High Byte								page 54
\$28 (\$48)	OCR1BL	Timer/Counter1 - Output Compare Register B Low Byte								page 54
\$27 (\$47)	TCCR2	FOC2	PWM2	COM21	COM20	CTC2	CS22	CS21	CS20	page 42
\$26 (\$46)	ASSR	-	-	-	-	AS20	TCON2UB	OCR2UB	TCR2UB	page 47
\$25 (\$45)	ICR1H	Timer/Counter1 - Input Capture Register High Byte								page 54
\$24 (\$44)	ICR1L	Timer/Counter1 - Input Capture Register Low Byte								page 54
\$23 (\$43)	TCNT2	Timer/Counter2 Counter Register								page 44
\$22 (\$42)	OCR2	Timer/Counter2 Output Compare Register								page 44
\$21 (\$41)	WDTCR	-	-	-	WDTOE	WDE	WDP2	WDP1	WDP0	page 58
\$20 (\$40)	UBRRH	UBRR1[11:8]				UBRR0[11:8]				page 78
\$1F (\$3F)	EEARH	-	-	-	-	-	-	-	EEAR8	page 60
\$1E (\$3E)	EEARL	EEPROM Address Register Low Byte								page 60
\$1D (\$3D)	EEDR	EEPROM Data Register								page 60
\$1C (\$3C)	EECR	-	-	-	-	EERIE	EEMWE	EEWE	EERE	page 61
\$1B (\$3B)	PORTA	PORTA7	PORTA6	PORTA5	PORTA4	PORTA3	PORTA2	PORTA1	PORTA0	page 89
\$1A (\$3A)	DDRA	DDA7	DDA6	DDA5	DDA4	DDA3	DDA2	DDA1	DDA0	page 89
\$19 (\$39)	PINA	PINA7	PINA6	PINA5	PINA4	PINA3	PINA2	PINA1	PINA0	page 89
\$18 (\$38)	PORTB	PORTB7	PORTB6	PORTB5	PORTB4	PORTB3	PORTB2	PORTB1	PORTB0	page 91
\$17 (\$37)	DDRB	DDB7	DDB6	DDB5	DDB4	DDB3	DDB2	DDB1	DDB0	page 91
\$16 (\$36)	PINB	PINB7	PINB6	PINB5	PINB4	PINB3	PINB2	PINB1	PINB0	page 91
\$15 (\$35)	PORTC	PORTC7	PORTC6	PORTC5	PORTC4	PORTC3	PORTC2	PORTC1	PORTC0	page 98
\$14 (\$34)	DDRC	DDC7	DDC6	DDC5	DDC4	DDC3	DDC2	DDC1	DDC0	page 98
\$13 (\$33)	PINC	PINC7	PINC6	PINC5	PINC4	PINC3	PINC2	PINC1	PINC0	page 98
\$12 (\$32)	PORTD	PORTD7	PORTD6	PORTD5	PORTD4	PORTD3	PORTD2	PORTD1	PORTD0	page 100
\$11 (\$31)	DDRD	DDD7	DDD6	DDD5	DDD4	DDD3	DDD2	DDD1	DDD0	page 100
\$10 (\$30)	PIND	PIND7	PIND6	PIND5	PIND4	PIND3	PIND2	PIND1	PIND0	page 100
\$0F (\$2F)	SPDR	SPI Data Register								page 68
\$0E (\$2E)	SPSR	SPIF	WCOL	-	-	-	-	-	SPI2X	page 67
\$0D (\$2D)	SPCR	SPIE	SPE	DORD	MSTR	CPOL	CPHA	SPR1	SPR0	page 66
\$0C (\$2C)	UDR0	UART0 I/O Data Register								page 73
\$0B (\$2B)	UCSR0A	RXC0	TXC0	UDRE0	FE0	OR0	-	U2X0	MPCM0	page 73
\$0A (\$2A)	UCSR0B	RXCIE0	TXCIE0	UDRIE0	RXEN0	TXEN0	CHR90	RXB80	TXB80	page 75
\$09 (\$29)	UBRR0	UART0 Baud Rate Register								page 78
\$08 (\$28)	ACSR	ACD	AINBG	ACO	ACI	ACIE	ACIC	ACIS1	ACIS0	page 81
\$07 (\$27)	PORTE	-	-	-	-	-	PORTE2	PORTE1	PORTE0	page 106
\$06 (\$26)	DDRE	-	-	-	-	-	DDE2	DDE1	DDE0	page 106
\$05 (\$25)	PINE	-	-	-	-	-	PINE2	PINE1	PINE0	page 106
\$04 (\$24)	Reserved									
\$03 (\$23)	UDR1	UART1 I/O Data Register								page 73
\$02 (\$22)	UCSR1A	RXC1	TXC1	UDRE1	FE1	OR1	-	U2X1	MPCM1	page 75
\$01 (\$21)	UCSR1B	RXCIE1	TXCIE1	UDRIE1	RXEN1	TXEN1	CHR91	RXB81	TXB81	page 73
\$00 (\$20)	UBRR1	UART1 Baud Rate Register								page 78

- Notes:
1. For compatibility with future devices, reserved bits should be written to zero if accessed. Reserved I/O memory addresses should never be written.
  2. Some of the Status Flags are cleared by writing a logical “1” to them. Note that the CBI and SBI instructions will operate on all bits in the I/O Register, writing a one back into any flag read as set, thus clearing the flag. The CBI and SBI instructions work with registers \$00 to \$1F only.

## Instruction Set Summary

Mnemonic	Operands	Description	Operation	Flags	# Clocks
<b>ARITHMETIC AND LOGIC INSTRUCTIONS</b>					
ADD	Rd, Rr	Add Two Registers	$Rd \leftarrow Rd + Rr$	Z,C,N,V,H	1
ADC	Rd, Rr	Add with Carry Two Registers	$Rd \leftarrow Rd + Rr + C$	Z,C,N,V,H	1
ADIW	Rdl, K	Add Immediate to Word	$Rdh:Rdl \leftarrow Rdh:Rdl + K$	Z,C,N,V,S	2
SUB	Rd, Rr	Subtract Two Registers	$Rd \leftarrow Rd - Rr$	Z,C,N,V,H	1
SUBI	Rd, K	Subtract Constant from Register	$Rd \leftarrow Rd - K$	Z,C,N,V,H	1
SBC	Rd, Rr	Subtract with Carry Two Registers	$Rd \leftarrow Rd - Rr - C$	Z,C,N,V,H	1
SBCI	Rd, K	Subtract with Carry Constant from Reg.	$Rd \leftarrow Rd - K - C$	Z,C,N,V,H	1
SBIW	Rdl, K	Subtract Immediate from Word	$Rdh:Rdl \leftarrow Rdh:Rdl - K$	Z,C,N,V,S	2
AND	Rd, Rr	Logical AND Registers	$Rd \leftarrow Rd \cdot Rr$	Z,N,V	1
ANDI	Rd, K	Logical AND Register and Constant	$Rd \leftarrow Rd \cdot K$	Z,N,V	1
OR	Rd, Rr	Logical OR Registers	$Rd \leftarrow Rd \vee Rr$	Z,N,V	1
ORI	Rd, K	Logical OR Register and Constant	$Rd \leftarrow Rd \vee K$	Z,N,V	1
EOR	Rd, Rr	Exclusive OR Registers	$Rd \leftarrow Rd \oplus Rr$	Z,N,V	1
COM	Rd	One's Complement	$Rd \leftarrow \$FF - Rd$	Z,C,N,V	1
NEG	Rd	Two's Complement	$Rd \leftarrow \$00 - Rd$	Z,C,N,V,H	1
SBR	Rd, K	Set Bit(s) in Register	$Rd \leftarrow Rd \vee K$	Z,N,V	1
CBR	Rd, K	Clear Bit(s) in Register	$Rd \leftarrow Rd \cdot (\$FF - K)$	Z,N,V	1
INC	Rd	Increment	$Rd \leftarrow Rd + 1$	Z,N,V	1
DEC	Rd	Decrement	$Rd \leftarrow Rd - 1$	Z,N,V	1
TST	Rd	Test for Zero or Minus	$Rd \leftarrow Rd \cdot Rd$	Z,N,V	1
CLR	Rd	Clear Register	$Rd \leftarrow Rd \oplus Rd$	Z,N,V	1
SER	Rd	Set Register	$Rd \leftarrow \$FF$	None	1
MUL	Rd, Rr	Multiply Unsigned	$R1:R0 \leftarrow Rd \times Rr$	Z,C	2
MULS	Rd, Rr	Multiply Signed	$R1:R0 \leftarrow Rd \times Rr$	Z,C	2
MULSU	Rd, Rr	Multiply Signed with Unsigned	$R1:R0 \leftarrow Rd \times Rr$	Z,C	2
FMUL	Rd, Rr	Fractional Multiply Unsigned	$R1:R0 \leftarrow (Rd \times Rr) \lll 1$	Z,C	2
FMULS	Rd, Rr	Fractional Multiply Signed	$R1:R0 \leftarrow (Rd \times Rr) \lll 1$	Z,C	2
FMULSU	Rd, Rr	Fractional Multiply Signed with Unsigned	$R1:R0 \leftarrow (Rd \times Rr) \lll 1$	Z,C	2
<b>BRANCH INSTRUCTIONS</b>					
RJMP	k	Relative Jump	$PC \leftarrow PC + k + 1$	None	2
IJMP		Indirect Jump to (Z)	$PC \leftarrow Z$	None	2
JMP	k	Direct Jump	$PC \leftarrow k$	None	3
RCALL	k	Relative Subroutine Call	$PC \leftarrow PC + k + 1$	None	3
ICALL		Indirect Call to (Z)	$PC \leftarrow Z$	None	3
CALL	k	Direct Subroutine Call	$PC \leftarrow k$	None	4
RET		Subroutine Return	$PC \leftarrow STACK$	None	4
RETI		Interrupt Return	$PC \leftarrow STACK$	I	4
CPSE	Rd, Rr	Compare, Skip if Equal	if $(Rd = Rr)$ $PC \leftarrow PC + 2$ or 3	None	1/2/3
CP	Rd, Rr	Compare	$Rd - Rr$	Z,N,V,C,H	1
CPC	Rd, Rr	Compare with Carry	$Rd - Rr - C$	Z,N,V,C,H	1
CPI	Rd, K	Compare Register with Immediate	$Rd - K$	Z,N,V,C,H	1
SBRC	Rr, b	Skip if Bit in Register Cleared	if $(Rr(b) = 0)$ $PC \leftarrow PC + 2$ or 3	None	1/2/3
SBRS	Rr, b	Skip if Bit in Register is Set	if $(Rr(b) = 1)$ $PC \leftarrow PC + 2$ or 3	None	1/2/3
SBIC	P, b	Skip if Bit in I/O Register Cleared	if $(P(b) = 0)$ $PC \leftarrow PC + 2$ or 3	None	1/2/3
SBIS	P, b	Skip if Bit in I/O Register is Set	if $(P(b) = 1)$ $PC \leftarrow PC + 2$ or 3	None	1/2/3
BRBS	s, k	Branch if Status Flag Set	if $(SREG(s) = 1)$ then $PC \leftarrow PC + k + 1$	None	1/2
BRBC	s, k	Branch if Status Flag Cleared	if $(SREG(s) = 0)$ then $PC \leftarrow PC + k + 1$	None	1/2
BREQ	k	Branch if Equal	if $(Z = 1)$ then $PC \leftarrow PC + k + 1$	None	1/2
BRNE	k	Branch if Not Equal	if $(Z = 0)$ then $PC \leftarrow PC + k + 1$	None	1/2
BRCS	k	Branch if Carry Set	if $(C = 1)$ then $PC \leftarrow PC + k + 1$	None	1/2
BRCC	k	Branch if Carry Cleared	if $(C = 0)$ then $PC \leftarrow PC + k + 1$	None	1/2
BRSH	k	Branch if Same or Higher	if $(C = 0)$ then $PC \leftarrow PC + k + 1$	None	1/2
BRLO	k	Branch if Lower	if $(C = 1)$ then $PC \leftarrow PC + k + 1$	None	1/2
BRMI	k	Branch if Minus	if $(N = 1)$ then $PC \leftarrow PC + k + 1$	None	1/2
BRPL	k	Branch if Plus	if $(N = 0)$ then $PC \leftarrow PC + k + 1$	None	1/2
BRGE	k	Branch if Greater or Equal, Signed	if $(N \oplus V = 0)$ then $PC \leftarrow PC + k + 1$	None	1/2
BRLT	k	Branch if Less than Zero, Signed	if $(N \oplus V = 1)$ then $PC \leftarrow PC + k + 1$	None	1/2
BRHS	k	Branch if Half-carry Flag Set	if $(H = 1)$ then $PC \leftarrow PC + k + 1$	None	1/2
BRHC	k	Branch if Half-carry Flag Cleared	if $(H = 0)$ then $PC \leftarrow PC + k + 1$	None	1/2

## Instruction Set Summary (Continued)

Mnemonic	Operands	Description	Operation	Flags	# Clocks
BRTS	k	Branch if T-flag Set	if (T = 1) then PC ← PC + k + 1	None	1/2
BRTC	k	Branch if T-flag Cleared	if (T = 0) then PC ← PC + k + 1	None	1/2
BRVS	k	Branch if Overflow Flag is Set	if (V = 1) then PC ← PC + k + 1	None	1/2
BRVC	k	Branch if Overflow Flag is Cleared	if (V = 0) then PC ← PC + k + 1	None	1/2
BRIE	k	Branch if Interrupt Enabled	if (I = 1) then PC ← PC + k + 1	None	1/2
BRID	k	Branch if Interrupt Disabled	if (I = 0) then PC ← PC + k + 1	None	1/2
<b>DATA TRANSFER INSTRUCTIONS</b>					
MOV	Rd, Rr	Move between Registers	Rd ← Rr	None	1
MOVW	Rd, Rr	Copy Register Word	Rd+1:Rd ← Rr+1:Rr	None	1
LDI	Rd, K	Load Immediate	Rd ← K	None	1
LD	Rd, X	Load Indirect	Rd ← (X)	None	2
LD	Rd, X+	Load Indirect and Post-inc.	Rd ← (X), X ← X + 1	None	2
LD	Rd, -X	Load Indirect and Pre-dec.	X ← X - 1, Rd ← (X)	None	2
LD	Rd, Y	Load Indirect	Rd ← (Y)	None	2
LD	Rd, Y+	Load Indirect and Post-inc.	Rd ← (Y), Y ← Y + 1	None	2
LD	Rd, -Y	Load Indirect and Pre-dec.	Y ← Y - 1, Rd ← (Y)	None	2
LDD	Rd, Y+q	Load Indirect with Displacement	Rd ← (Y + q)	None	2
LD	Rd, Z	Load Indirect	Rd ← (Z)	None	2
LD	Rd, Z+	Load Indirect and Post-inc.	Rd ← (Z), Z ← Z + 1	None	2
LD	Rd, -Z	Load Indirect and Pre-dec.	Z ← Z - 1, Rd ← (Z)	None	2
LDD	Rd, Z+q	Load Indirect with Displacement	Rd ← (Z + q)	None	2
LDS	Rd, k	Load Direct from SRAM	Rd ← (k)	None	2
ST	X, Rr	Store Indirect	(X) ← Rr	None	2
ST	X+, Rr	Store Indirect and Post-inc.	(X) ← Rr, X ← X + 1	None	2
ST	-X, Rr	Store Indirect and Pre-dec.	X ← X - 1, (X) ← Rr	None	2
ST	Y, Rr	Store Indirect	(Y) ← Rr	None	2
ST	Y+, Rr	Store Indirect and Post-inc.	(Y) ← Rr, Y ← Y + 1	None	2
ST	-Y, Rr	Store Indirect and Pre-dec.	Y ← Y - 1, (Y) ← Rr	None	2
STD	Y+q, Rr	Store Indirect with Displacement	(Y + q) ← Rr	None	2
ST	Z, Rr	Store Indirect	(Z) ← Rr	None	2
ST	Z+, Rr	Store Indirect and Post-inc.	(Z) ← Rr, Z ← Z + 1	None	2
ST	-Z, Rr	Store Indirect and Pre-dec.	Z ← Z - 1, (Z) ← Rr	None	2
STD	Z+q, Rr	Store Indirect with Displacement	(Z + q) ← Rr	None	2
STS	k, Rr	Store Direct to SRAM	(k) ← Rr	None	2
LPM		Load Program Memory	R0 ← (Z)	None	3
LPM	Rd, Z	Load Program Memory	Rd ← (Z)	None	3
LPM	Rd, Z+	Load Program Memory and Post-inc.	Rd ← (Z), Z ← Z + 1	None	3
SPM		Store Program Memory	(Z) ← R1:R0	None	-
IN	Rd, P	In Port	Rd ← P	None	1
OUT	P, Rr	Out Port	P ← Rr	None	1
PUSH	Rr	Push Register on Stack	STACK ← Rr	None	2
POP	Rd	Pop Register from Stack	Rd ← STACK	None	2
<b>BIT AND BIT-TEST INSTRUCTIONS</b>					
SBI	P, b	Set Bit in I/O Register	I/O(P,b) ← 1	None	2
CBI	P, b	Clear Bit in I/O Register	I/O(P,b) ← 0	None	2
LSL	Rd	Logical Shift Left	Rd(n+1) ← Rd(n), Rd(0) ← 0	Z,C,N,V	1
LSR	Rd	Logical Shift Right	Rd(n) ← Rd(n+1), Rd(7) ← 0	Z,C,N,V	1
ROL	Rd	Rotate Left through Carry	Rd(0) ← C, Rd(n+1) ← Rd(n), C ← Rd(7)	Z,C,N,V	1
ROR	Rd	Rotate Right through Carry	Rd(7) ← C, Rd(n) ← Rd(n+1), C ← Rd(0)	Z,C,N,V	1
ASR	Rd	Arithmetic Shift Right	Rd(n) ← Rd(n+1), n = 0..6	Z,C,N,V	1
SWAP	Rd	Swap Nibbles	Rd(3..0) ← Rd(7..4), Rd(7..4) ← Rd(3..0)	None	1
BSET	s	Flag Set	SREG(s) ← 1	SREG(s)	1
BCLR	s	Flag Clear	SREG(s) ← 0	SREG(s)	1
BST	Rr, b	Bit Store from Register to T	T ← Rr(b)	T	1
BLD	Rd, b	Bit Load from T to Register	Rd(b) ← T	None	1
SEC		Set Carry	C ← 1	C	1
CLC		Clear Carry	C ← 0	C	1
SEN		Set Negative Flag	N ← 1	N	1
CLN		Clear Negative Flag	N ← 0	N	1

## Instruction Set Summary (Continued)

Mnemonic	Operands	Description	Operation	Flags	# Clocks
SEZ		Set Zero Flag	$Z \leftarrow 1$	Z	1
CLZ		Clear Zero Flag	$Z \leftarrow 0$	Z	1
SEI		Global Interrupt Enable	$I \leftarrow 1$	I	1
CLI		Global Interrupt Disable	$I \leftarrow 0$	I	1
SES		Set Signed Test Flag	$S \leftarrow 1$	S	1
CLS		Clear Signed Test Flag	$S \leftarrow 0$	S	1
SEV		Set Two's Complement Overflow	$V \leftarrow 1$	V	1
CLV		Clear Two's Complement Overflow	$V \leftarrow 0$	V	1
SET		Set T in SREG	$T \leftarrow 1$	T	1
CLT		Clear T in SREG	$T \leftarrow 0$	T	1
SEH		Set Half-carry Flag in SREG	$H \leftarrow 1$	H	1
CLH		Clear Half-carry Flag in SREG	$H \leftarrow 0$	H	1
NOP		No Operation		None	1
SLEEP		Sleep	(see specific descr. for Sleep function)	None	3
WDR		Watchdog Reset	(see specific descr. for WDR/timer)	None	1

## Ordering Information

Speed (MHz)	Power Supply	Ordering Code	Package	Operation Range
4	2.7 - 5.5V	ATmega161-4AC	44A	Commercial (0°C to 70°C)
		ATmega161-4PC	40P6	
8	4.0 - 5.5V	ATmega161-4AI	44A	Industrial (-40°C to 85°C)
		ATmega161-4PI	40P6	
8	4.0 - 5.5V	ATmega161-8AC	44A	Commercial (0°C to 70°C)
		ATmega161-8PC	40P6	
8	4.0 - 5.5V	ATmega161-8AI	44A	Industrial (-40°C to 85°C)
		ATmega161-8PI	40P6	

Note: This device can also be supplied in wafer form. Please contact your local Atmel sales office for detailed ordering information and minimum quantities.

Package Type	
<b>44A</b>	44-lead, Thin (1.0 mm) Plastic Quad Flat Package (TQFP)
<b>40P6</b>	40-lead, 0.600" Wide, Plastic Dual Inline Package (PDIP)

# Packaging Information

44A

**COMMON DIMENSIONS**  
(Unit of Measure = mm)

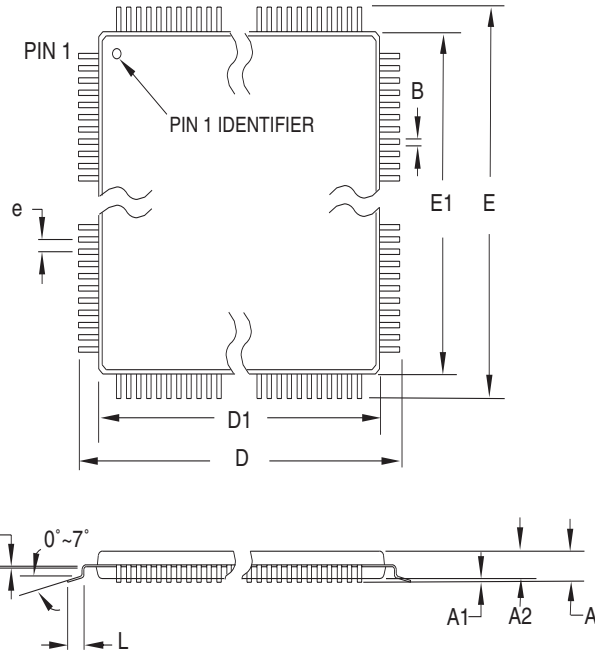
SYMBOL	MIN	NOM	MAX	NOTE
A	-	-	1.20	
A1	0.05	-	0.15	
A2	0.95	1.00	1.05	
D	11.75	12.00	12.25	
D1	9.90	10.00	10.10	Note 2
E	11.75	12.00	12.25	
E1	9.90	10.00	10.10	Note 2
B	0.30	-	0.45	
C	0.09	-	0.20	
L	0.45	-	0.75	
e	0.80 TYP			

Notes: 1. This package conforms to JEDEC reference MS-026, Variation ACB.  
2. Dimensions D1 and E1 do not include mold protrusion. Allowable protrusion is 0.25 mm per side. Dimensions D1 and E1 are maximum plastic body size dimensions including mold mismatch.  
3. Lead coplanarity is 0.10 mm maximum.

10/5/2001

2325 Orchard Parkway San Jose, CA 95131	<b>TITLE</b>	<b>DRAWING NO.</b>	<b>REV.</b>
	44A, 44-lead, 10 x 10 mm Body Size, 1.0 mm Body Thickness, 0.8 mm Lead Pitch, Thin Profile Plastic Quad Flat Package (TQFP)	44A	B

40P6



**COMMON DIMENSIONS**  
(Unit of Measure = mm)

SYMBOL	MIN	NOM	MAX	NOTE
A	-	-	1.20	
A1	0.05	-	0.15	
A2	0.95	1.00	1.05	
D	11.75	12.00	12.25	
D1	9.90	10.00	10.10	Note 2
E	11.75	12.00	12.25	
E1	9.90	10.00	10.10	Note 2
B	0.30	-	0.45	
C	0.09	-	0.20	
L	0.45	-	0.75	
e	0.80 TYP			

- Notes:
1. This package conforms to JEDEC reference MS-026, Variation ACB.
  2. Dimensions D1 and E1 do not include mold protrusion. Allowable protrusion is 0.25 mm per side. Dimensions D1 and E1 are maximum plastic body size dimensions including mold mismatch.
  3. Lead coplanarity is 0.10 mm maximum.

10/5/2001

 2325 Orchard Parkway San Jose, CA 95131	<b>TITLE</b> 44A, 44-lead, 10 x 10 mm Body Size, 1.0 mm Body Thickness, 0.8 mm Lead Pitch, Thin Profile Plastic Quad Flat Package (TQFP)	<b>DRAWING NO.</b>	<b>REV.</b>
		44A	B

## Errata

### ATmega161 Rev. E

- PWM not Phase Correct
- Increased Interrupt Latency
- Interrupt Return Fails when Stack Pointer Addresses the External Memory
- Writing UBBRH Affects both UART0 and UART1
- Store Program Memory Instruction May Fail

#### 5. PWM not Phase Correct

In phase correct PWM mode, a change from OCRx = TOP to anything less than TOP does not change the OCx output. This gives a phase error in the following period.

##### Problem Fix/Workaround

Make sure this issue is not harmful to the application.

#### 4. Increased Interrupt Latency

In this device, some instructions are not interruptable, and will cause the interrupt latency to increase. The only practical problem concerns a loop followed by a two-word instruction while waiting for an interrupt. The loop may consist of a branch instruction or an absolute or relative jump back to itself like this:

```
loop: rjmp loop
<Two-word instruction>
```

In this case, a dead-lock situation arises.

##### Problem Fix/Workaround

In assembly, insert a nop instruction immediately after a loop to itself. The problem will normally be detected during development. In C, the only construct that will give this problem is an empty “for” loop; “for(;;)”. Use “while(1)” or “do{} while (1)” to avoid the problem.

#### 3. Interrupt Return Fails when Stack Pointer Addresses the External Memory

When Stack Pointer addresses external memory (SPH:SPL > \$45F), returning from interrupt will fail. The program counter will be updated with a wrong value and thus the program flow will be corrupted.

##### Problem Fix/Workaround

Address the stack pointer to internal SRAM or disable interrupts while Stack Pointer addresses external memory.

#### 2. Writing UBBRH Affects Both UART0 and UART1

Writing UBRRHI updates baud rate generator for both UART0 and UART1. The baud rate generator's counter is updated each time either UBRR or UBRRHI are written. Since the UBRRHI register is shared by UART0 and UART1, changing the baud rate for one UART will affect the operation of the other UART.

##### Problem Fix/Workaround

Do not update UBRRHI for one UART when transmitting/receiving data on the other.

## 1. Store Program Memory Instruction May Fail

At certain frequencies and voltages, the store program memory (SPM) instruction may fail.

### **Problem Fix/Workaround**

Avoid using the SPM instruction.



## Data Sheet Change Log for ATmega161

This document contains a log on the changes made to the data sheet for ATmega161.

**Changes from Rev. 1228C-08/02 to Rev. 1228D-02/07**

- 1 Package Drawing updated from rev. A to rev. B.
- 2 Written "Not recommend in new designs" on features page.

**Changes from Rev. 1228B-09/01 to Rev. 1228C-08/02**

All page numbers refers to this document.

- 1 Description of Brown-out Detector (BOD) removed from data sheet.

## Table of Contents

<b>Features.....</b>	<b>1</b>
<b>Disclaimer.....</b>	<b>1</b>
<b>Pin Configuration.....</b>	<b>2</b>
<b>Description .....</b>	<b>3</b>
Block Diagram .....	4
Pin Descriptions.....	5
Crystal Oscillator.....	6
<b>Architectural Overview.....</b>	<b>7</b>
The General Purpose Register File .....	10
ALU – Arithmetic Logic Unit.....	11
Self-programmable Flash Program Memory.....	11
EEPROM Data Memory.....	11
SRAM Data Memory.....	12
Program and Data Addressing Modes.....	13
Memory Access Times and Instruction Execution Timing .....	17
I/O Memory .....	19
Reset and Interrupt Handling.....	22
MCU Control Register – MCUCR .....	34
Sleep Modes.....	36
<b>Timer/Counters .....</b>	<b>38</b>
Timer/Counter Prescalers.....	38
8-bit Timer/Counters T/C0 and T/C2 .....	40
Timer/Counter1.....	49
<b>Watchdog Timer.....</b>	<b>58</b>
<b>EEPROM Read/Write Access.....</b>	<b>60</b>
Prevent EEPROM Corruption .....	62
<b>Serial Peripheral Interface – SPI.....</b>	<b>63</b>
$\overline{SS}$ Pin Functionality.....	65
Data Modes .....	65
<b>UARTs.....</b>	<b>69</b>
Data Transmission.....	69
Data Reception .....	71
UART Control .....	73
Baud Rate Generator.....	76
Double-speed Transmission .....	78
<b>Analog Comparator .....</b>	<b>81</b>



<b>Internal Voltage Reference .....</b>	<b>83</b>
Voltage Reference Enable Signals and Start-up Time .....	83
<b>Interface to External Memory .....</b>	<b>84</b>
Using the External Memory Interface .....	88
<b>I/O Ports.....</b>	<b>89</b>
Port A.....	89
Port B.....	91
Port B Schematics .....	94
Port C.....	98
Port D.....	100
Port E.....	106
<b>Memory Programming.....</b>	<b>110</b>
Boot Loader Support.....	110
Entering the Boot Loader Program .....	111
Capabilities of the Boot Loader.....	112
Self-programming the Flash .....	112
<b>Program Memory Lock bits .....</b>	<b>116</b>
Fuse bits .....	116
Signature Bytes .....	117
Programming the Flash and EEPROM.....	117
Parallel Programming .....	118
Parallel Programming Characteristics .....	124
Serial Downloading.....	125
Serial Programming Characteristics .....	129
<b>Electrical Characteristics.....</b>	<b>130</b>
Absolute Maximum Ratings* .....	130
<b>DC Characteristics.....</b>	<b>131</b>
External Clock Drive Waveforms .....	132
External Data Memory Timing .....	133
<b>Typical Characteristics .....</b>	<b>138</b>
<b>Register Summary .....</b>	<b>144</b>
<b>Instruction Set Summary .....</b>	<b>146</b>
<b>Ordering Information.....</b>	<b>149</b>
<b>Packaging Information .....</b>	<b>150</b>
44A .....	150

40P6 .....	151
<b>Errata .....</b>	<b>152</b>
ATmega161 Rev. E .....	152
<b>Data Sheet Change Log for ATmega161 .....</b>	<b>154</b>
Changes from Rev. 1228B-09/01 to Rev. 1228C-08/02 .....	154
<b>Table of Contents .....</b>	<b>i</b>





## Atmel Corporation

2325 Orchard Parkway  
San Jose, CA 95131, USA  
Tel: 1(408) 441-0311  
Fax: 1(408) 487-2600

## Regional Headquarters

### Europe

Atmel Sarl  
Route des Arsenalux 41  
Case Postale 80  
CH-1705 Fribourg  
Switzerland  
Tel: (41) 26-426-5555  
Fax: (41) 26-426-5500

### Asia

Room 1219  
Chinachem Golden Plaza  
77 Mody Road Tsimshatsui  
East Kowloon  
Hong Kong  
Tel: (852) 2721-9778  
Fax: (852) 2722-1369

### Japan

9F, Tonetsu Shinkawa Bldg.  
1-24-8 Shinkawa  
Chuo-ku, Tokyo 104-0033  
Japan  
Tel: (81) 3-3523-3551  
Fax: (81) 3-3523-7581

## Atmel Operations

### Memory

2325 Orchard Parkway  
San Jose, CA 95131, USA  
Tel: 1(408) 441-0311  
Fax: 1(408) 436-4314

### Microcontrollers

2325 Orchard Parkway  
San Jose, CA 95131, USA  
Tel: 1(408) 441-0311  
Fax: 1(408) 436-4314

La Chantrerie  
BP 70602  
44306 Nantes Cedex 3, France  
Tel: (33) 2-40-18-18-18  
Fax: (33) 2-40-18-19-60

### ASIC/ASSP/Smart Cards

Zone Industrielle  
13106 Rousset Cedex, France  
Tel: (33) 4-42-53-60-00  
Fax: (33) 4-42-53-60-01

1150 East Cheyenne Mtn. Blvd.  
Colorado Springs, CO 80906, USA  
Tel: 1(719) 576-3300  
Fax: 1(719) 540-1759

Scottish Enterprise Technology Park  
Maxwell Building  
East Kilbride G75 0QR, Scotland  
Tel: (44) 1355-803-000  
Fax: (44) 1355-242-743

### RF/Automotive

Theresienstrasse 2  
Postfach 3535  
74025 Heilbronn, Germany  
Tel: (49) 71-31-67-0  
Fax: (49) 71-31-67-2340

1150 East Cheyenne Mtn. Blvd.  
Colorado Springs, CO 80906, USA  
Tel: 1(719) 576-3300  
Fax: 1(719) 540-1759

### Biometrics/Imaging/Hi-Rel MPU/ High Speed Converters/RF Datacom

Avenue de Rochepleine  
BP 123  
38521 Saint-Egreve Cedex, France  
Tel: (33) 4-76-58-30-00  
Fax: (33) 4-76-58-34-80

---

## Literature Requests

[www.atmel.com/literature](http://www.atmel.com/literature)

**Disclaimer:** The information in this document is provided in connection with Atmel products. No license, express or implied, by estoppel or otherwise, to any intellectual property right is granted by this document or in connection with the sale of Atmel products. **EXCEPT AS SET FORTH IN ATMEL'S TERMS AND CONDITIONS OF SALE LOCATED ON ATMEL'S WEB SITE, ATMEL ASSUMES NO LIABILITY WHATSOEVER AND DISCLAIMS ANY EXPRESS, IMPLIED OR STATUTORY WARRANTY RELATING TO ITS PRODUCTS INCLUDING, BUT NOT LIMITED TO, THE IMPLIED WARRANTY OF MERCHANTABILITY, FITNESS FOR A PARTICULAR PURPOSE, OR NON-INFRINGEMENT. IN NO EVENT SHALL ATMEL BE LIABLE FOR ANY DIRECT, INDIRECT, CONSEQUENTIAL, PUNITIVE, SPECIAL OR INCIDENTAL DAMAGES (INCLUDING, WITHOUT LIMITATION, DAMAGES FOR LOSS OF PROFITS, BUSINESS INTERRUPTION, OR LOSS OF INFORMATION) ARISING OUT OF THE USE OR INABILITY TO USE THIS DOCUMENT, EVEN IF ATMEL HAS BEEN ADVISED OF THE POSSIBILITY OF SUCH DAMAGES.** Atmel makes no representations or warranties with respect to the accuracy or completeness of the contents of this document and reserves the right to make changes to specifications and product descriptions at any time without notice. Atmel does not make any commitment to update the information contained herein. Unless specifically provided otherwise, Atmel products are not suitable for, and shall not be used in, automotive applications. Atmel's products are not intended, authorized, or warranted for use as components in applications intended to support or sustain life.

© 2007 Atmel Corporation. All rights reserved. ATMEL®, logo and combinations thereof, Everywhere You Are®, AVR®, AVR Studio®, and others, are registered trademarks or trademarks of Atmel Corporation or its subsidiaries. Other terms and product names may be trademarks of others. ATMEL® and AVR® are the registered trademarks of Atmel.

Other terms and product names may be the trademarks of others.

## Looking for pricing, stock, or lifecycle information?

Click below to explore more details on WIN SOURCE:

 [View ATMEGA161-8PI on WIN SOURCE](#)

 [Atmel Information](#)

## Optimize Your Supply Chain with WIN SOURCE Solutions

-  Global Sourcing Solution
-  Obsolete Management
-  Cost Control Management
-  Shortage Management
-  Alternative Solution
-  Excess Inventory Management