



**THE DATASHEET OF
CY7C1051DV33-12BAXI**



8-Mbit (512 K × 16) Static RAM

Features

- Temperature ranges
 - -40 °C to 85 °C
- High speed
 - $t_{AA} = 10 \text{ ns}$
- Low active power
 - $I_{CC} = 110 \text{ mA}$ at $f = 100 \text{ MHz}$
- Low CMOS standby power
 - $I_{SB2} = 20 \text{ mA}$
- 2.0-V data retention
- Automatic power-down when deselected
- Transistor-transistor logic (TTL)-compatible inputs and outputs
- Easy memory expansion with \overline{CE} and \overline{OE} features
- Available in Pb-free 48-ball fine ball grid array (FBGA) and 44-pin thin small outline package (TSOP) II packages

Functional Description

The CY7C1051DV33 is a high performance CMOS Static RAM organized as 512 K words by 16-bits.

To write to the device, take Chip Enable (\overline{CE}) and Write Enable (\overline{WE}) inputs LOW. If Byte LOW Enable (\overline{BLE}) is LOW, then data from I/O pins (I/O_0 – I/O_7), is written into the location specified on the address pins (A_0 – A_{18}). If Byte HIGH Enable (\overline{BHE}) is LOW, then data from I/O pins (I/O_8 – I/O_{15}) is written into the location specified on the address pins (A_0 – A_{18}).

To read from the device, take Chip Enable (\overline{CE}) and Output Enable (\overline{OE}) LOW while forcing the Write Enable (\overline{WE}) HIGH. If Byte LOW Enable (\overline{BLE}) is LOW, then data from the memory location specified by the address pins appears on I/O_0 – I/O_7 . If Byte HIGH Enable (\overline{BHE}) is LOW, then data from memory appears on I/O_8 to I/O_{15} . See the [Truth Table](#) on page 10 for a complete description of read and write modes.

The input/output pins (I/O_0 – I/O_{15}) are placed in a high-impedance state when the device is deselected (\overline{CE} HIGH), the outputs are disabled (\overline{OE} HIGH), the \overline{BHE} and \overline{BLE} are disabled (\overline{BHE} , \overline{BLE} HIGH), or a write operation (\overline{CE} LOW, and \overline{WE} LOW) is in progress.

The CY7C1051DV33 is available in a 44-pin TSOP II package with center power and ground (revolutionary) pinout and a 48-ball FBGA package.

For a complete list of related documentation, click [here](#).

Logic Block Diagram

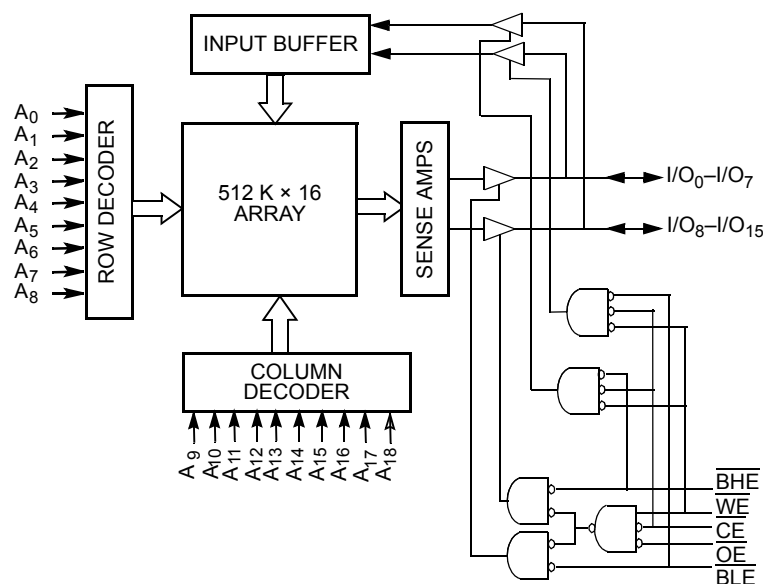

Contents

Pin Configurations	3	Ordering Information	11
Selection Guide	3	Ordering Code Definitions	11
Maximum Ratings	4	Package Diagrams	12
Operating Range	4	Acronyms	13
DC Electrical Characteristics	4	Document Conventions	13
Capacitance	4	Units of Measure	13
Thermal Resistance	4	Document History Page	14
AC Test Loads and Waveforms	5	Sales, Solutions, and Legal Information	15
Data Retention Characteristics	5	Worldwide Sales and Design Support	15
Data Retention Waveform	5	Products	15
AC Switching Characteristics	6	PSoC® Solutions	15
Switching Waveforms	7	Cypress Developer Community	15
Truth Table	10	Technical Support	15

Pin Configurations

Figure 1. Pin Diagram - 48-ball FBGA (Top View)^[1]

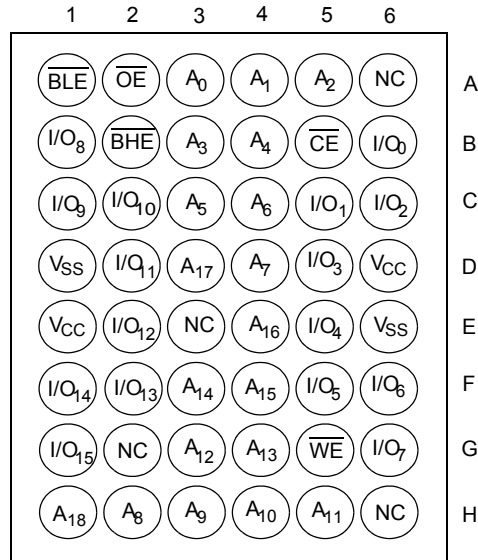
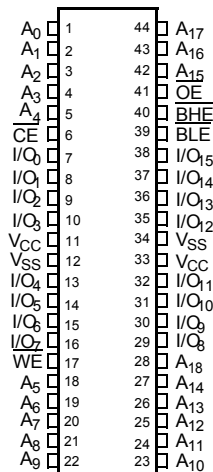

Figure 2. Pin Diagram - 44-Pin TSOP II (Top View)^[1]



Selection Guide

Description	-10	-12	Unit
Maximum access time	10	12	ns
Maximum operating current	110	100	mA
Maximum CMOS standby current	20	20	mA

Note

1. NC pins are not connected on the die.

Maximum Ratings

Exceeding the maximum ratings may shorten the useful life of the device. These user guidelines are not tested.

Storage temperature -65 °C to +150 °C
 Ambient temperature with power applied..... -55 °C to +125 °C
 Supply voltage on V_{CC} to relative GND^[2] -0.5 V to +4.6 V
 DC voltage applied to outputs in high-Z state^[2] -0.3 V to V_{CC} + 0.3 V
 DC input voltage^[2] -0.3 V to V_{CC} + 0.3 V
 Current into outputs (LOW)..... 20 mA

Static discharge voltage..... >2001 V
 (per MIL-STD-883, Method 3015)
 Latch-up current >200 mA

Operating Range

Range	Ambient Temperature	V _{CC}	Speed
Industrial	-40 °C to +85 °C	3.3 V ± 0.3 V	10 ns
Industrial	-40 °C to +85 °C	3.3 V ± 0.3 V	12 ns

DC Electrical Characteristics

Over the Operating Range

Parameter	Description	Test Conditions	-10		-12		Unit
			Min	Max	Min	Max	
V _{OH}	Output HIGH voltage	Min V _{CC} , I _{OH} = -4.0 mA	2.4	-	2.4	-	V
V _{OL}	Output LOW voltage	Min V _{CC} , I _{OL} = 8.0 mA	-	0.4	-	0.4	V
V _{IH} ^[2]	Input HIGH voltage		2.0	V _{CC} + 0.3	2.0	V _{CC} + 0.3	V
V _{IL} ^[2]	Input LOW voltage		-0.3	0.8	-0.3	0.8	V
I _{IX}	Input leakage current	GND ≤ V _{IN} ≤ V _{CC}	-1	+1	-1	+1	μA
I _{OZ}	Output leakage current	GND ≤ V _{OUT} ≤ V _{CC} , Output Disabled	-1	+1	-1	+1	μA
I _{CC}	V _{CC} operating supply current	f = f _{MAX} = 1/t _{RC}	-	110	-	100	mA
I _{SB1}	Automatic CE power down current —TTL inputs	Max V _{CC} , $\overline{CE} \geq V_{IH}$, V _{IN} ≥ V _{IH} or V _{IN} ≤ V _{IL} , f = f _{MAX}	-	40	-	35	mA
I _{SB2}	Automatic CE Power Down Current —CMOS Inputs	Max V _{CC} , $\overline{CE} \geq V_{CC} - 0.3 V$, V _{IN} ≥ V _{CC} - 0.3 V or V _{IN} ≤ 0.3 V, f = 0	-	20	-	20	mA

Capacitance

Tested initially and after any design or process changes that may affect these parameters.

Parameter	Description	Test Conditions	Max	Unit
C _{IN}	Input capacitance	T _A = 25 °C, f = 1 MHz, V _{CC} = 3.3 V	12	pF
C _{OUT}	I/O capacitance		12	pF

Thermal Resistance

Tested initially and after any design or process changes that may affect these parameters.

Parameter	Description	Test Conditions	FBGA Package	TSOP II Package	Unit
θ _{JA}	Thermal resistance (Junction to ambient)	Still air, soldered on a 3 × 4.5 inch, four-layer printed circuit board	28.31	51.43	°C/W
θ _{JC}	Thermal resistance (Junction to case)		11.4	15.8	°C/W

Note

2. V_{IL(min)} = -2.0 V and V_{IH(max)} = V_{CC} + 2.0 V for pulse durations of less than 20 ns.

AC Test Loads and Waveforms

AC characteristics (except High-Z) are tested using the load conditions shown in Figure 3 (a). High-Z characteristics are tested for all speeds using the test load shown in Figure 3 (c).

Figure 3. AC Test Loads and Waveforms

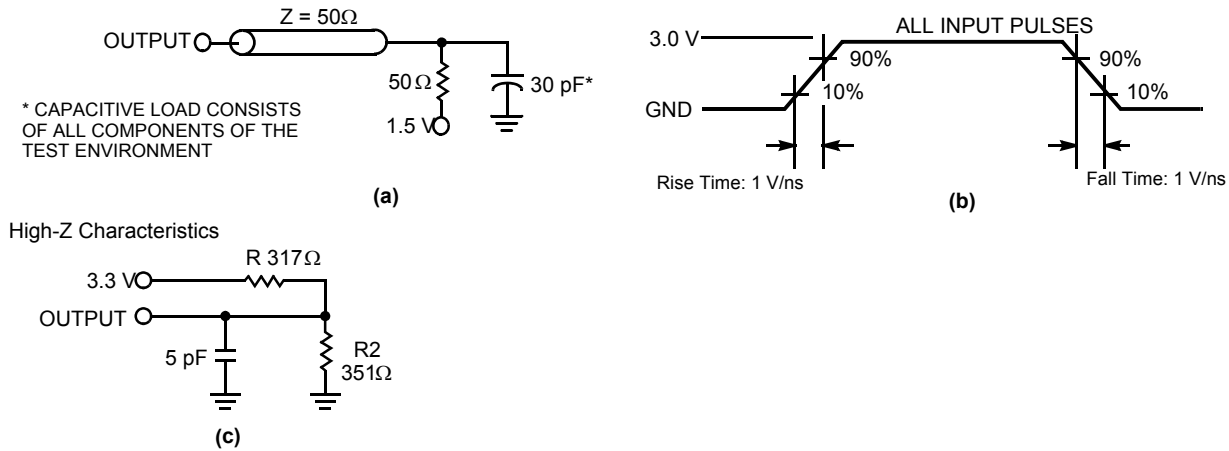

Data Retention Characteristics

Over the Operating Range

Parameter	Description	Conditions ^[3]	Min	Max	Unit
V_{DR}	V_{CC} for Data Retention		2.0	–	V
I_{CCDR}	Data Retention Current	$V_{CC} = V_{DR} = 2.0\text{ V}$, $\overline{CE} \geq V_{CC} - 0.3\text{ V}$, $V_{IN} \geq V_{CC} - 0.3\text{ V}$ or $V_{IN} \leq 0.3\text{ V}$	–	20	mA
$t_{CDR}^{[4]}$	Chip Deselect to Data Retention Time		0	–	ns
$t_R^{[4]}$	Operation Recovery Time		t_{RC}	–	ns

Data Retention Waveform

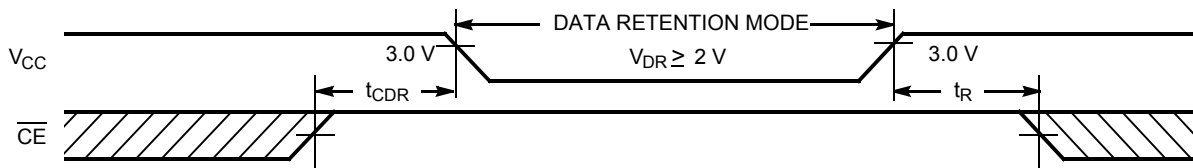

Notes

- 3. No inputs may exceed $V_{CC} + 0.3\text{ V}$
- 4. Full device operation requires linear V_{CC} ramp from V_{DR} to $V_{CC}(\text{min}) \geq 50\ \mu\text{s}$ or stable at $V_{CC}(\text{min}) \geq 50\ \mu\text{s}$.

AC Switching Characteristics

Over the Operating Range^[5]

Parameter	Description	-10		-12		Unit
		Min	Max	Min	Max	
Read Cycle						
$t_{power}^{[6]}$	V_{CC} (typical) to the First Access	100	–	100	–	μ s
t_{RC}	Read Cycle Time	10	–	12	–	ns
t_{AA}	Address to Data Valid	–	10	–	12	ns
t_{OHA}	Data Hold from Address Change	2.5	–	2.5	–	ns
t_{ACE}	\overline{CE} LOW to Data Valid	–	10	–	12	ns
t_{DOE}	\overline{OE} LOW to Data Valid	–	5	–	6	ns
t_{LZOE}	\overline{OE} LOW to Low-Z	0	–	0	–	ns
t_{HZOE}	\overline{OE} HIGH to High-Z ^[7, 8]	–	5	–	6	ns
t_{LZCE}	\overline{CE} LOW to Low-Z ^[8]	3	–	3	–	ns
t_{HZCE}	\overline{CE} HIGH to High-Z ^[7, 8]	–	5	–	6	ns
t_{PU}	\overline{CE} LOW to Power Up	0	–	0	–	ns
t_{PD}	\overline{CE} HIGH to Power Down	–	10	–	12	ns
t_{DBE}	Byte Enable to Data Valid	–	5	–	6	ns
t_{LZBE}	Byte Enable to Low-Z	0	–	0	–	ns
t_{HZBE}	Byte Disable to High-Z	–	5	–	6	ns
Write Cycle^[9, 10]						
t_{WC}	Write Cycle Time	10	–	12	–	ns
t_{SCE}	\overline{CE} LOW to Write End	7	–	8	–	ns
t_{AW}	Address Setup to Write End	7	–	8	–	ns
t_{HA}	Address Hold from Write End	0	–	0	–	ns
t_{SA}	Address Setup to Write Start	0	–	0	–	ns
t_{PWE}	\overline{WE} Pulse Width	7	–	8	–	ns
t_{SD}	Data Setup to Write End	5	–	6	–	ns
t_{HD}	Data Hold from Write End	0	–	0	–	ns
t_{LZWE}	\overline{WE} HIGH to Low-Z ^[8]	3	–	3	–	ns
t_{HZWE}	\overline{WE} LOW to High-Z ^[7, 8]	–	5	–	6	ns
t_{BW}	Byte Enable to End of Write	7	–	8	–	ns

Notes

- Test conditions assume signal transition time of 3 ns or less, timing reference levels of 1.5 V, input pulse levels of 0 to 3.0 V.
- t_{POWER} gives the minimum amount of time that the power supply must be at typical V_{CC} values until the first memory access can be performed.
- t_{HZOE} , t_{HZCE} , t_{HZBE} and t_{HZWE} are specified with a load capacitance of 5 pF as in part (d) of "AC Test Loads and Waveforms" on page 5. Transition is measured when the outputs enter a high impedance state.
- At any temperature and voltage condition, t_{HZCE} is less than t_{LZCE} , t_{HZOE} is less than t_{LZOE} , t_{HZBE} is less than t_{LZBE} , and t_{HZWE} is less than t_{LZWE} for any device.
- The internal write time of the memory is defined by the overlap of \overline{CE} LOW, and \overline{WE} LOW. \overline{CE} and \overline{WE} must be LOW to initiate a write, and the transition of either of these signals can terminate the write. The input data setup and hold timing must refer to the leading edge of the signal that terminates the write.
- The minimum write cycle time for Write Cycle No. 3 (\overline{WE} controlled, \overline{OE} LOW) is the sum of t_{HZWE} and t_{SD} .

Switching Waveforms

Figure 4. Read Cycle No. 1^[11, 12]

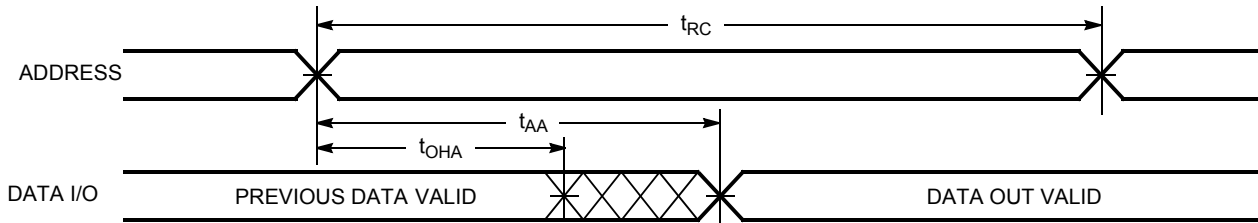
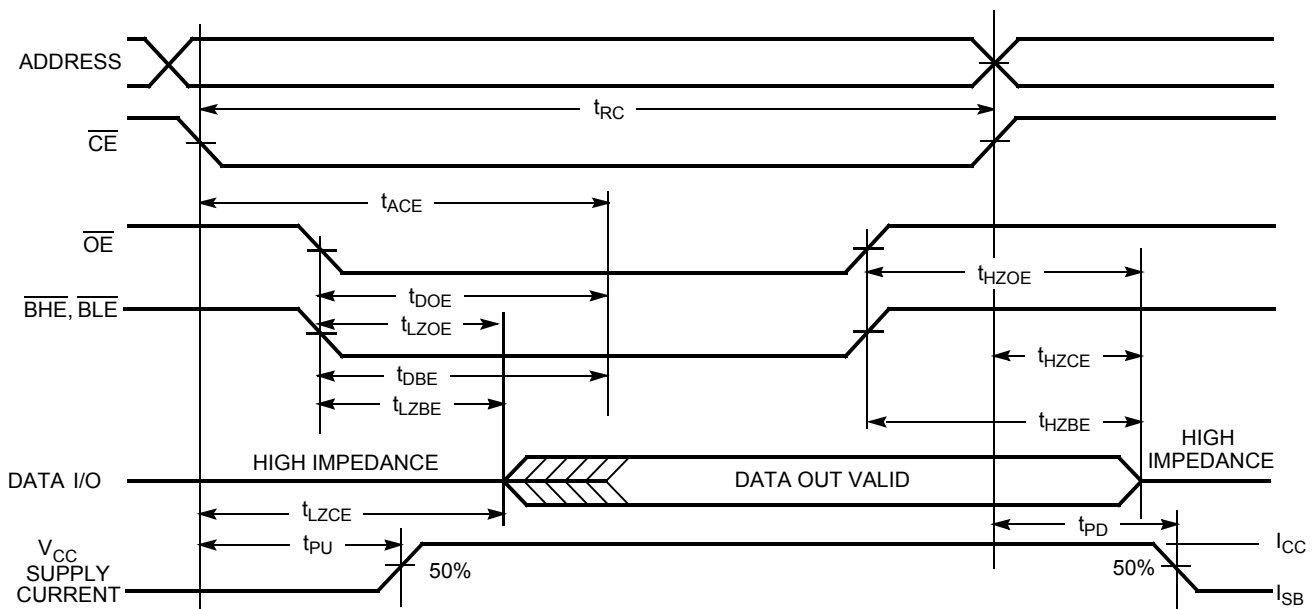

Figure 5. Read Cycle No. 2 (\overline{OE} Controlled)^[12, 13]



Notes

- 11. Device is continuously selected. \overline{OE} , $\overline{CE} = V_{IL}$, \overline{BHE} , \overline{BLE} , or both = V_{IL} .
- 12. \overline{WE} is HIGH for Read cycle.
- 13. Address valid before or coincident with \overline{CE} transition LOW.

Switching Waveforms (continued)

Figure 6. Write Cycle No. 1 ($\overline{\text{CE}}$ Controlled) [14, 15]

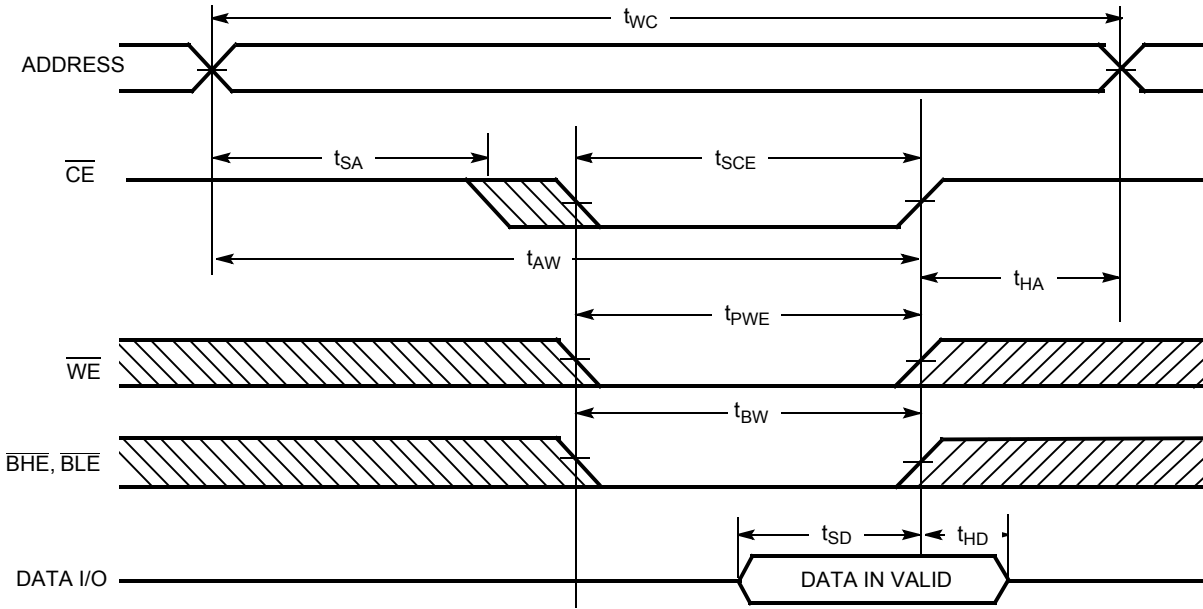
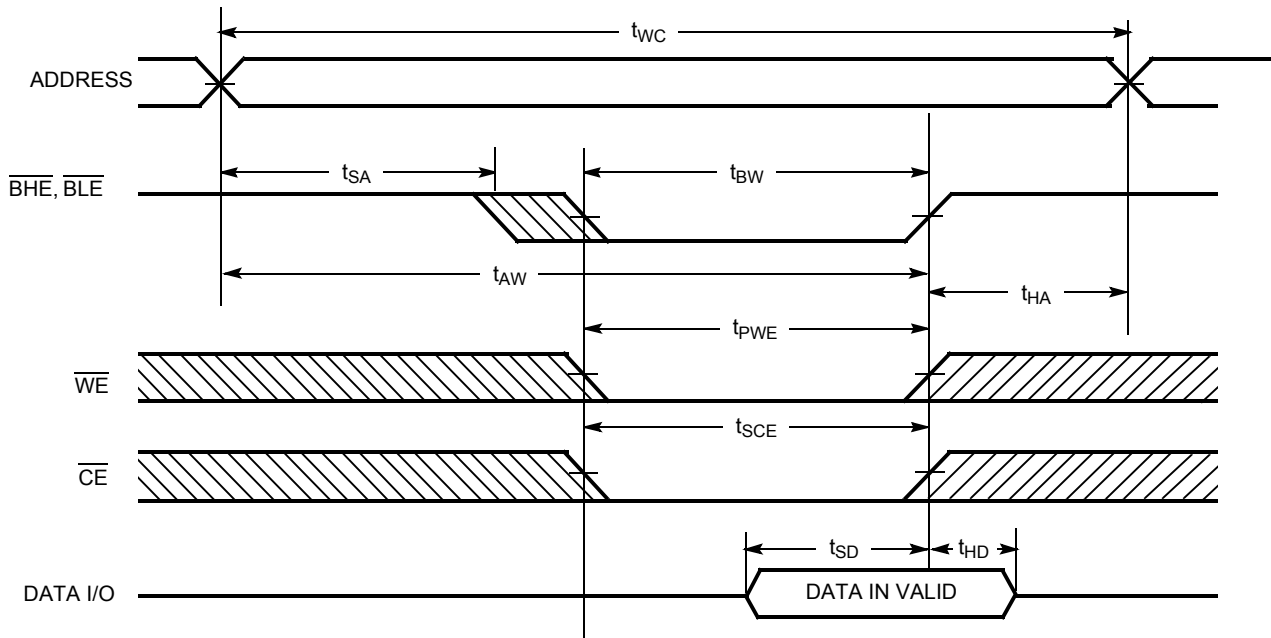

Figure 7. Write Cycle No. 2 ($\overline{\text{BLE}}$ or $\overline{\text{BHE}}$ Controlled)



Notes

- 14. Data I/O is high-impedance if $\overline{\text{OE}}$, or $\overline{\text{BHE}}$, $\overline{\text{BLE}}$, or both = V_{IH} .
- 15. If $\overline{\text{CE}}$ goes HIGH simultaneously with $\overline{\text{WE}}$ going HIGH, the output remains in a high-impedance state.

Switching Waveforms (continued)

Figure 8. Write Cycle No. 3 (\overline{WE} Controlled, \overline{OE} LOW) [16]

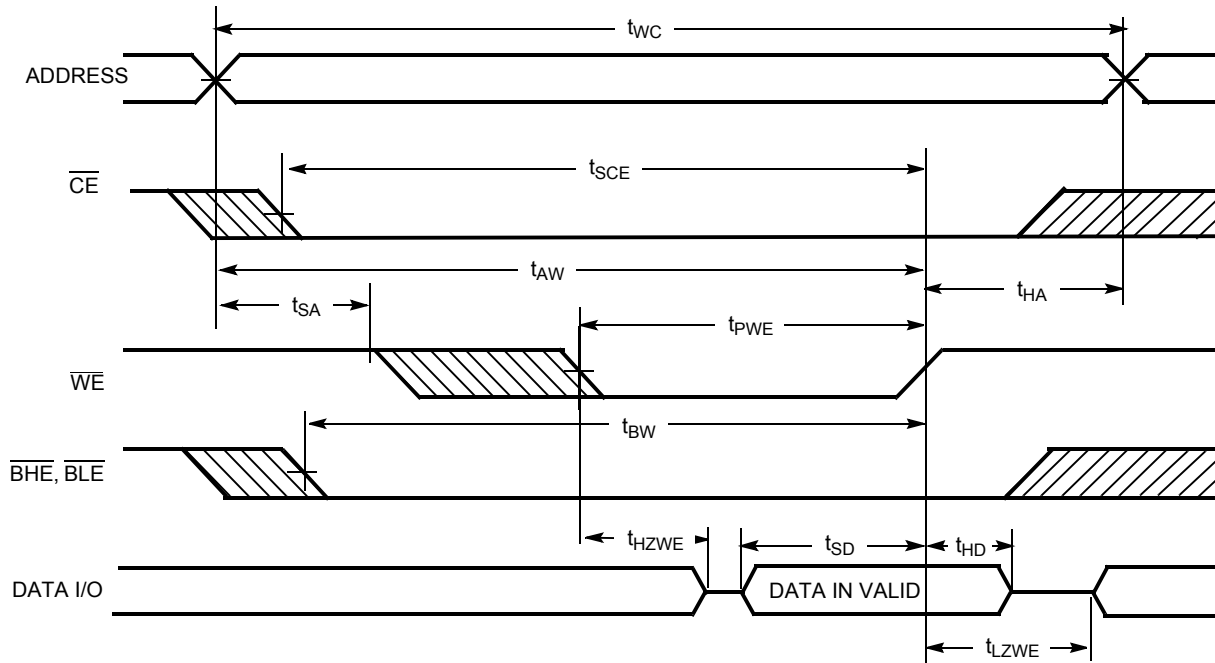

Note

16. The minimum write cycle time for Write Cycle No. 3 (\overline{WE} controlled, \overline{OE} LOW) is the sum of t_{HZWE} and t_{SD} .

Truth Table

$\overline{\text{CE}}$	$\overline{\text{OE}}$	$\overline{\text{WE}}$	$\overline{\text{BLE}}$	$\overline{\text{BHE}}$	I/O ₀ -I/O ₇	I/O ₈ -I/O ₁₅	Mode	Power
H	X	X	X	X	High-Z	High-Z	Power Down	Standby (I _{SB})
L	L	H	L	L	Data Out	Data Out	Read All Bits	Active (I _{CC})
L	L	H	L	H	Data Out	High-Z	Read Lower Bits Only	Active (I _{CC})
L	L	H	H	L	High-Z	Data Out	Read Upper Bits Only	Active (I _{CC})
L	X	L	L	L	Data In	Data In	Write All Bits	Active (I _{CC})
L	X	L	L	H	Data In	High-Z	Write Lower Bits Only	Active (I _{CC})
L	X	L	H	L	High-Z	Data In	Write Upper Bits Only	Active (I _{CC})
L	H	H	X	X	High-Z	High-Z	Selected, Outputs Disabled	Active (I _{CC})

Ordering Information

Cypress offers other versions of this type of product in many different configurations and features. The following table contains only the list of parts that are currently available. For a complete listing of all options, visit the Cypress website at www.cypress.com and refer to the product summary page at <http://www.cypress.com/products> or contact your local sales representative. Cypress maintains a worldwide network of offices, solution centers, manufacturer's representatives and distributors. To find the office closest to you, visit us at <http://www.cypress.com/go/datasheet/offices>.

Speed (ns)	Ordering Code	Package Diagram	Package Type	Operating Range
10	CY7C1051DV33-10BAXI	51-85193	48-ball FBGA (Pb-free)	Industrial
	CY7C1051DV33-10ZSXI	51-85087	44-pin TSOP II (Pb-free)	
12	CY7C1051DV33-12ZSXI	51-85087	44-pin TSOP II (Pb-free)	Industrial

Contact your local Cypress sales representative for availability of these parts.

Ordering Code Definitions

CY 7 C 1 05 1 D V33 - XX XXX X

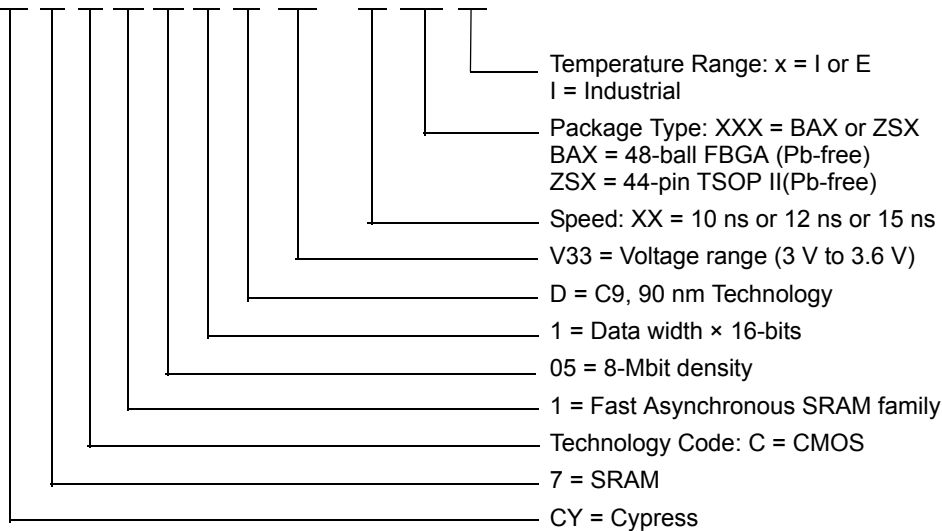

Package Diagrams

Figure 9. 48-Ball FBGA (6 x 8 x 1.2 mm), 51-85193

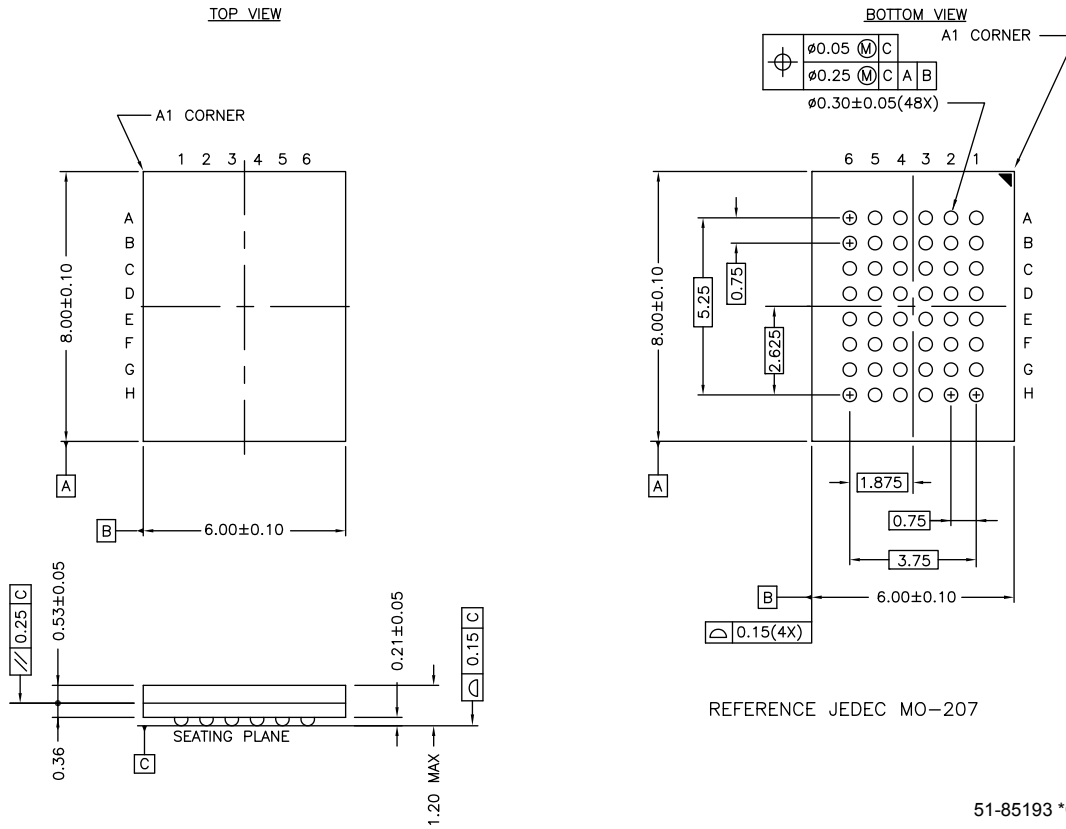

Package Diagrams (continued)

Figure 10. 44-Pin Thin Small Outline Package Type II, 51-85087

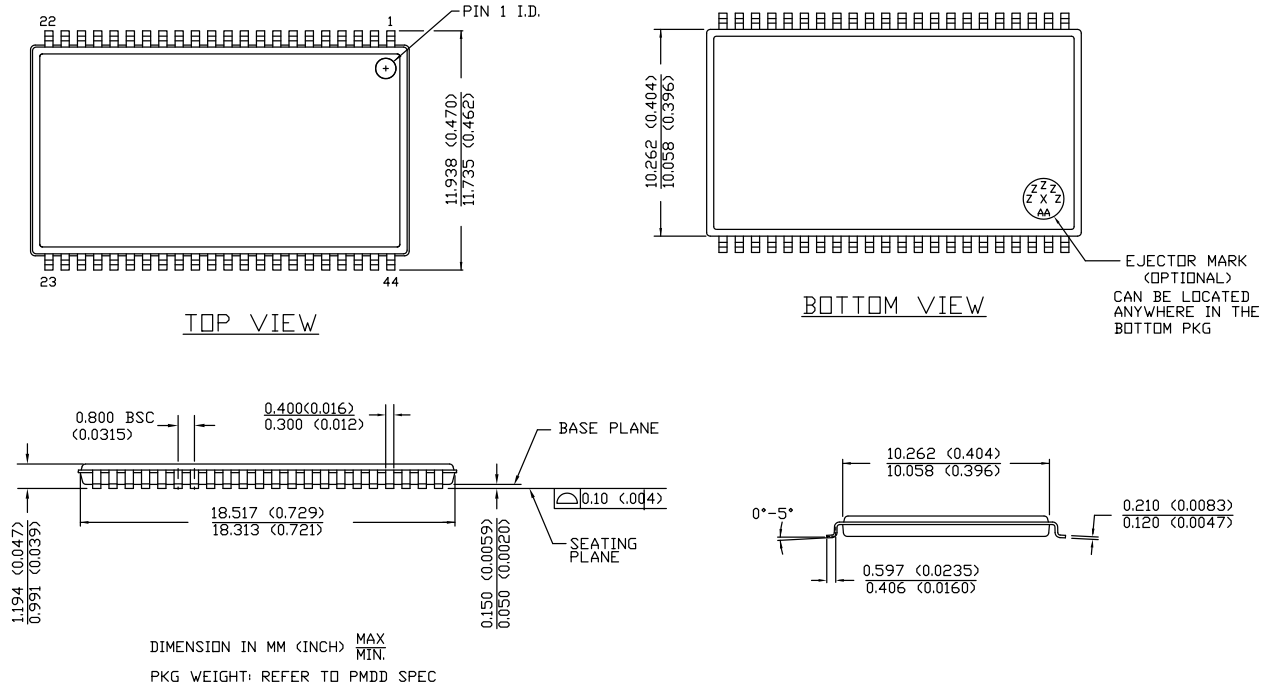

51-85087 *E

Acronyms

Acronym	Description
CE	chip enable
CMOS	complementary metal oxide semiconductor
I/O	input/output
OE	output enable
SRAM	static random access memory
SOJ	small outline J-lead
TSOP	thin small outline package
VFBGA	very fine-pitch ball grid array

Document Conventions

Units of Measure

Symbol	Unit of Measure
ns	nanosecond
V	volt
µA	microampere
mA	milliampere
mV	millivolt
mW	milliwatt
MHz	megahertz
pF	picofarad
°C	degree Celsius
W	watt

Document History Page

Document Title: CY7C1051DV33, 8-Mbit (512 K × 16) Static RAM Document Number: 001-00063				
Revision	ECN	Orig. of Change	Submission Date	Description of Change
**	342195	PCI	See ECN	New Datasheet
*A	380574	SYT	See ECN	Redefined I _{CC} values for Com'l and Ind'l temperature ranges I _{CC} (Com'l): Changed from 110, 90 and 80 mA to 110, 100 and 95 mA for 8, 10 and 12 ns speed bins respectively I _{CC} (Ind'l): Changed from 110, 90 and 80 mA to 120, 110 and 105 mA for 8, 10 and 12 ns speed bins respectively Changed the Capacitance values from 8 pF to 10 pF on Page # 3
*B	485796	NXR	See ECN	Changed address of Cypress Semiconductor Corporation on Page# 1 from "3901 North First Street" to "198 Champion Court" Removed -8 and -12 Speed bins from product offering, Removed Commercial Operating Range option, Modified Maximum Ratings for DC input voltage from -0.5 V to -0.3 V and V _{CC} + 0.5 V to V _{CC} + 0.3 V Changed the Description of I _{IX} from Input Load Current to Input Leakage Current. Changed t _{HZBE} from 5 ns to 6 ns Updated footnote #7 on High-Z parameter measurement Added footnote #11 Updated the Ordering Information table and Replaced Package Name column with Package Diagram.
*C	866000	NXR	See ECN	Changed ball E3 from V _{SS} to NC in FBGA pin configuration
*D	1513285	VKN/AESA	See ECN	Converted from preliminary to final Changed t _{HZBE} from 6 ns to 5 ns for 10 ns speed bin Added 12 ns speed bin Changed t _{OHA} spec from 3 ns to 2.5 ns Updated Ordering information table
*E	2911009	VKN	04/12/10	Replaced 48-Ball (7 x 8.5 x 1.2 mm) FBGA with 48-Ball (6 x 8 x 1.2mm) FBGA, Updated Package diagrams, Updated ordering information.
*F	3086522	PRAS	11/15/2010	Included Auto-E information (preliminary) in Ordering Information .
*G	3112625	AJU	12/16/2010	Added Ordering Code Definitions .
*H	3369149	TAVA	09/12/2011	Removed all references to Automotive information.
*I	4530449	MEMJ	10/10/2014	Updated Switching Waveforms : Added Note 16 and referred the same note in Figure 8 . Updated Package Diagrams : spec 51-85087 – Changed revision from *D to *E. Updated in new template. Completing Sunset Review.
*J	4578447	MEMJ	01/16/2015	Added related documentation hyperlink in page 1. Removed the prune part number CY7C1051DV33-12BAXI in Ordering Information .

Sales, Solutions, and Legal Information

Worldwide Sales and Design Support

Cypress maintains a worldwide network of offices, solution centers, manufacturer's representatives, and distributors. To find the office closest to you, visit us at [Cypress Locations](#).

Products

Automotive	cypress.com/go/automotive
Clocks & Buffers	cypress.com/go/clocks
Interface	cypress.com/go/interface
Lighting & Power Control	cypress.com/go/powerpsoc
Memory	cypress.com/go/memory
PSoC	cypress.com/go/psoc
Touch Sensing	cypress.com/go/touch
USB Controllers	cypress.com/go/USB
Wireless/RF	cypress.com/go/wireless

PSoC[®] Solutions

psoc.cypress.com/solutions
PSoC 1 | PSoC 3 | PSoC 4 | PSoC 5LP

Cypress Developer Community

[Community](#) | [Forums](#) | [Blogs](#) | [Video](#) | [Training](#)

Technical Support

cypress.com/go/support

© Cypress Semiconductor Corporation, 2005-2015. The information contained herein is subject to change without notice. Cypress Semiconductor Corporation assumes no responsibility for the use of any circuitry other than circuitry embodied in a Cypress product. Nor does it convey or imply any license under patent or other rights. Cypress products are not warranted nor intended to be used for medical, life support, life saving, critical control or safety applications, unless pursuant to an express written agreement with Cypress. Furthermore, Cypress does not authorize its products for use as critical components in life-support systems where a malfunction or failure may reasonably be expected to result in significant injury to the user. The inclusion of Cypress products in life-support systems application implies that the manufacturer assumes all risk of such use and in doing so indemnifies Cypress against all charges.

Any Source Code (software and/or firmware) is owned by Cypress Semiconductor Corporation (Cypress) and is protected by and subject to worldwide patent protection (United States and foreign), United States copyright laws and international treaty provisions. Cypress hereby grants to licensee a personal, non-exclusive, non-transferable license to copy, use, modify, create derivative works of, and compile the Cypress Source Code and derivative works for the sole purpose of creating custom software and or firmware in support of licensee product to be used only in conjunction with a Cypress integrated circuit as specified in the applicable agreement. Any reproduction, modification, translation, compilation, or representation of this Source Code except as specified above is prohibited without the express written permission of Cypress.

Disclaimer: CYPRESS MAKES NO WARRANTY OF ANY KIND, EXPRESS OR IMPLIED, WITH REGARD TO THIS MATERIAL, INCLUDING, BUT NOT LIMITED TO, THE IMPLIED WARRANTIES OF MERCHANTABILITY AND FITNESS FOR A PARTICULAR PURPOSE. Cypress reserves the right to make changes without further notice to the materials described herein. Cypress does not assume any liability arising out of the application or use of any product or circuit described herein. Cypress does not authorize its products for use as critical components in life-support systems where a malfunction or failure may reasonably be expected to result in significant injury to the user. The inclusion of Cypress' product in a life-support systems application implies that the manufacturer assumes all risk of such use and in doing so indemnifies Cypress against all charges.

Use may be limited by and subject to the applicable Cypress software license agreement.

Looking for pricing, stock, or lifecycle information?

Click below to explore more details on WIN SOURCE:

- [View CY7C1051DV33-12BAXI on WIN SOURCE](#)
- [Cypress Semiconductor Corp Information](#)

Optimize Your Supply Chain with WIN SOURCE Solutions

- ✓ Global Sourcing Solution
- ✓ Obsolete Management
- ✓ Cost Control Management
- ✓ Shortage Management
- ✓ Alternative Solution
- ✓ Excess Inventory Management