



**THE DATASHEET OF
CY7C0833V-100BBI**





CY7C0831AV
 CY7C0832AV
 CY7C0833V

FLE_x18™ 3.3 V, 128K/256K/512K × 18 Synchronous Dual-Port RAM

Features

- True dual-ported memory cells that allow simultaneous access of the same memory location
- Synchronous pipelined operation
- Family of 2-Mbit, 4-Mbit, and 9-Mbit devices
- Pipelined output mode allows fast operation
- 0.18 micron CMOS for optimum speed and power
- High speed clock to data access
- 3.3 V low power
 - Active as low as 225 mA (typ)
 - Standby as low as 55 mA (typ)
- Mailbox function for message passing
- Global master reset
- Separate byte enables on both ports
- Commercial and Industrial temperature ranges
- IEEE 1149.1 compatible JTAG boundary scan
- 144-ball FBGA (13 mm × 13 mm (1.0 mm pitch))
- 120-pin TQFP (14 mm × 14 mm × 1.4 mm)
- Pb-free packages available
- Counter wrap around control
 - Internal mask register controls counter wrap around
 - Counter-interrupt flags to indicate wrap around
 - Memory block retransmit operation
- Counter readback on address lines
- Mask register readback on address lines
- Dual chip enables on both ports for easy depth expansion

Functional Description

The FLE_x18™ family includes 2-Mbit, 4-Mbit, and 9-Mbit pipelined, synchronous, true dual port static RAMs that are high speed, low power 3.3 V CMOS. Two ports are provided, permitting independent, simultaneous access to any location in memory. The result of writing to the same location by more than one port at the same time is undefined. Registers on control, address, and data lines allow for minimal setup and hold time.

During a Read operation, data is registered for decreased cycle time. Each port contains a burst counter on the input address register. After externally loading the counter with the initial address, the counter increments the address internally (more details to follow). The internal Write pulse width is independent of the duration of the R/W input signal. The internal Write pulse is self-timed to allow the shortest possible cycle times.

A HIGH on \overline{CE}_0 or LOW on CE_1 for one clock cycle powers down the internal circuitry to reduce the static power consumption. One cycle with chip enables asserted is required to reactivate the outputs.

Additional features include: readback of burst-counter internal address value on address lines, counter-mask registers to control the counter wrap around, counter interrupt (CNTINT) flags, readback of mask register value on address lines, retransmit functionality, interrupt flags for message passing, JTAG for boundary scan, and asynchronous Master Reset (MRST).

The CY7C0833V device in this family has limited features. See [Address Counter and Mask Register Operations on page 8](#) for details.

For a complete list of related documentation, [click here](#).

Product Selection Guide

Density	2-Mbit (128K × 18)	4-Mbit (256K × 18)	9-Mbit (512K × 18)
Part Number	CY7C0831AV	CY7C0832AV	CY7C0833V
Maximum Speed (MHz)	133	167	100
Maximum Access Time - Clock to Data (ns)	4.0	4.0	4.7
Typical Operating Current (mA)	225	225	270
Package	120-pin TQFP	120-pin TQFP	144-ball FBGA

Logic Block Diagram [1]

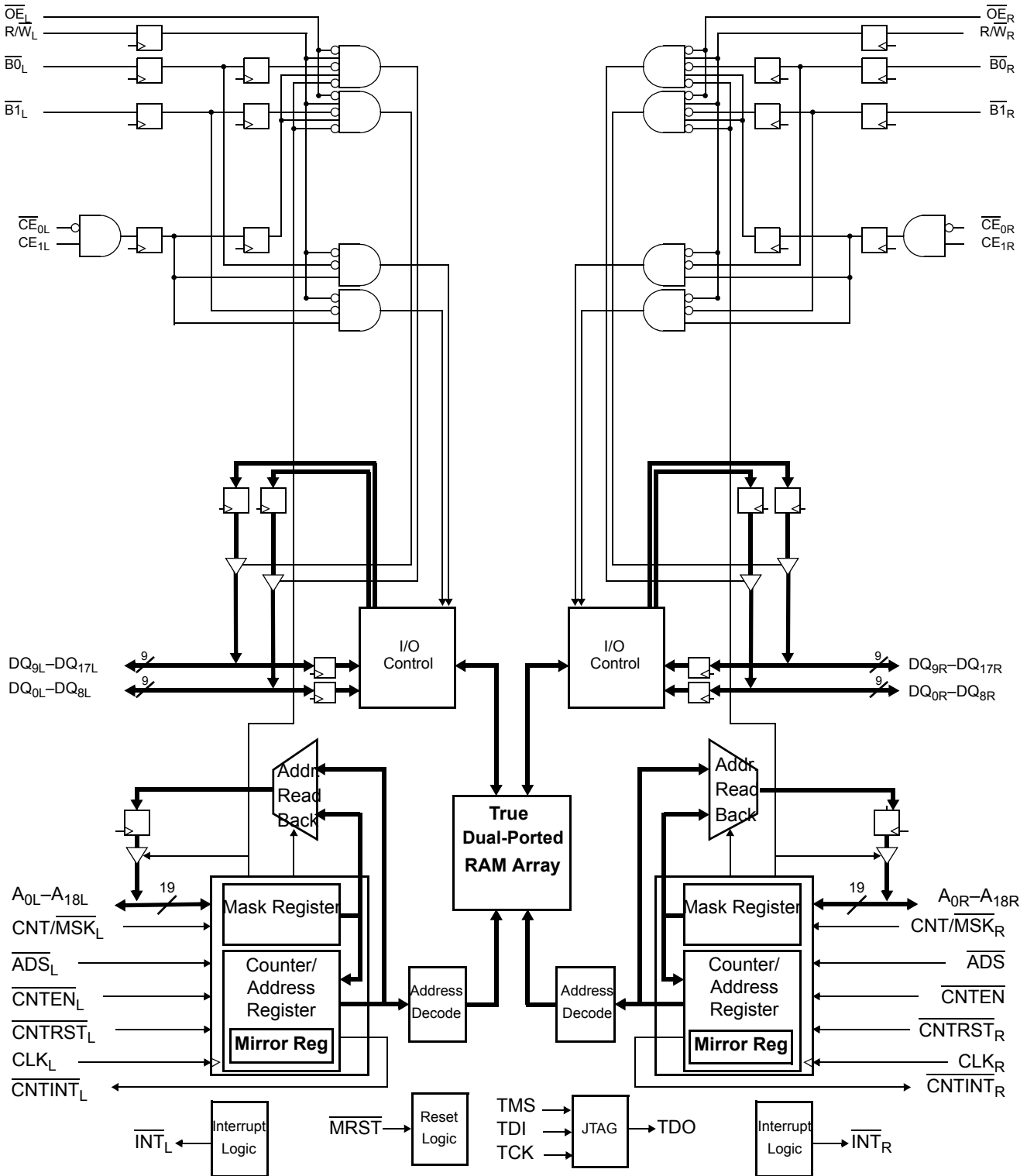

Note

1. CY7C0831AV has 17 address bits, CY7C0832AV has 18 address bits and CY7C0833V has 19 address bits.

Contents

Pin Configurations	4	Capacitance	15
Pin Definitions	6	AC Test Load and Waveforms	15
Byte Select Operation	7	Switching Characteristics	16
Master Reset	7	Switching Waveforms	18
Mailbox Interrupts	7	JTAG Timing and Switching Characteristics	26
Address Counter and Mask Register Operations	8	JTAG Switching Waveforms	26
Counter Reset Operation	9	Read/Write and Enable Operation	27
Counter Load Operation	9	Ordering Information	28
Counter Increment Operation	9	512K × 18 (9M) 3.3 V	28
Counter Hold Operation	10	Synchronous CY7C0833V Dual-Port SRAM	28
Counter Interrupt	10	256K × 18 (4M) 3.3 V	28
Counter Readback Operation	10	Synchronous CY7C0832AV Dual-Port SRAM	28
Retransmit	10	128K × 18 (2M) 3.3 V	28
Mask Reset Operation	10	Synchronous CY7C0831AV Dual-Port SRAM	28
Mask Load Operation	10	Ordering Code Definitions	28
Mask Readback Operation	10	Package Diagrams	29
Counting by Two	10	Acronyms	30
IEEE 1149.1 Serial Boundary Scan (JTAG) ^[24]	12	Document Conventions	30
Performing a TAP Reset	12	Units of Measure	30
Performing a Pause/Restart	12	Document History Page	31
Boundary Scan Hierarchy for 9-Mbit Device	12	Sales, Solutions, and Legal Information	33
Identification Register Definitions	13	Worldwide Sales and Design Support	33
Scan Registers Sizes	13	Products	33
Instruction Identification Codes	13	PSoC® Solutions	33
Maximum Ratings	14	Cypress Developer Community	33
Operating Range	14	Technical Support	33
Electrical Characteristics	14		

Pin Configurations

Figure 1. 144-ball BGA pinout (Top View)

CY7C0833V

	1	2	3	4	5	6	7	8	9	10	11	12
A	DQ17 _L	DQ16 _L	DQ14 _L	DQ12 _L	DQ10 _L	DQ9 _L	DQ9 _R	DQ10 _R	DQ12 _R	DQ14 _R	DQ16 _R	DQ17 _R
B	A0 _L	A1 _L	DQ15 _L	DQ13 _L	DQ11 _L	$\overline{\text{MRST}}$	NC	DQ11 _R	DQ13 _R	DQ15 _R	A1 _R	A0 _R
C	A2 _L	A3 _L	CE1 _L ^[2]	$\overline{\text{INT}}_{\text{L}}$	$\overline{\text{CNTINT}}_{\text{L}}$ ^[3]	$\overline{\text{ADS}}_{\text{L}}$ ^[4]	$\overline{\text{ADS}}_{\text{R}}$ ^[4]	$\overline{\text{CNTINT}}_{\text{R}}$ ^[3]	$\overline{\text{INT}}_{\text{R}}$	CE1 _R ^[2]	A3 _R	A2 _R
D	A4 _L	A5 _L	$\overline{\text{CE}}0_{\text{L}}$ ^[4]	NC	VDD	VDD	VDD	VDD	NC	$\overline{\text{CE}}0_{\text{R}}$ ^[4]	A5 _R	A4 _R
E	A6 _L	A7 _L	$\overline{\text{B}}1_{\text{L}}$	NC	VDD	VSS	VSS	VDD	NC	$\overline{\text{B}}1_{\text{R}}$	A7 _R	A6 _R
F	A8 _L	A9 _L	C _L	NC	VSS	VSS	VSS	VSS	NC	C _R	A9 _R	A8 _R
G	A10 _L	A11 _L	$\overline{\text{B}}0_{\text{L}}$	NC	VSS	VSS	VSS	VSS	NC	$\overline{\text{B}}0_{\text{R}}$	A11 _R	A10 _R
H	A12 _L	A13 _L	$\overline{\text{OE}}_{\text{L}}$	NC	VDD	VSS	VSS	VDD	NC	$\overline{\text{OE}}_{\text{R}}$	A13 _R	A12 _R
J	A14 _L	A15	$\overline{\text{RW}}_{\text{L}}$	NC	VDD	VDD	VDD	VDD	NC	$\overline{\text{RW}}_{\text{R}}$	A15 _R	A14 _R
K	A16 _L	A17 _L	CNT/ $\overline{\text{MSK}}_{\text{L}}$ ^[2]	TDO	$\overline{\text{CNRST}}_{\text{L}}$ ^[2]	TCK	TMS	$\overline{\text{CNRST}}_{\text{R}}$ ^[2]	TDI	CNT/ $\overline{\text{MSK}}_{\text{R}}$ ^[2]	A17 _R	A16 _R
L	A18 _L	NC	DQ6 _L	DQ4 _L	DQ2 _L	$\overline{\text{CNTEN}}_{\text{L}}$ ^[4]	$\overline{\text{CNTEN}}_{\text{R}}$ ^[4]	DQ2 _R	DQ4 _R	DQ6 _R	NC	A18 _R
M	DQ8 _L	DQ7 _L	DQ5 _L	DQ3 _L	DQ1 _L	DQ0 _L	DQ0 _R	DQ1 _R	DQ3 _R	DQ5 _R	DQ7 _R	DQ8 _R

Notes

2. These balls are not applicable for CY7C0833V device. They must be tied to VDD.
3. These balls are not applicable for CY7C0833V device. They must not be connected.
4. These balls are not applicable for CY7C0833V device. They must be tied to VSS.

Pin Configurations (continued)

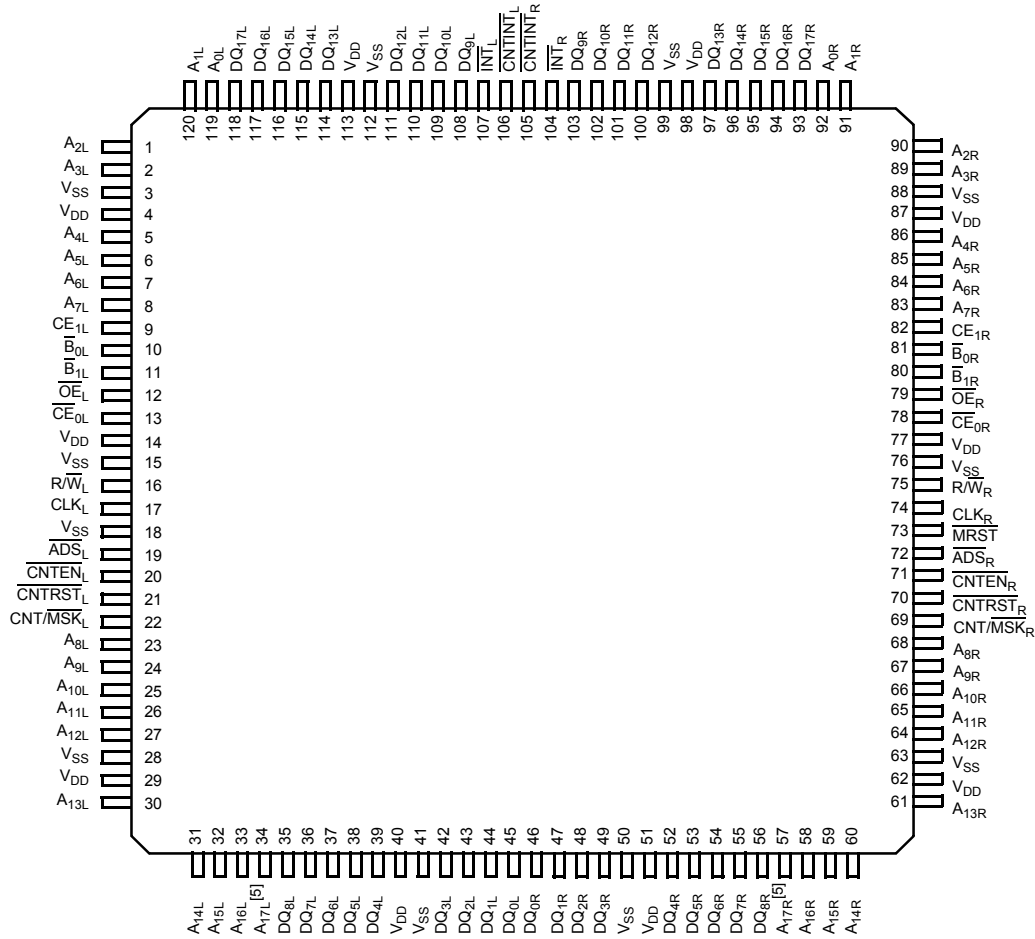
Figure 2. 120-pin TQFP pinout (Top View)
CY7C0831AV / CY7C0832AV

Note

5. Leave this pin unconnected for CY7C0831AV.

Pin Definitions

Left Port	Right Port	Description
A _{0L} –A _{18L} ^[6]	A _{0R} –A _{18R} ^[6]	Address Inputs.
ADS _L ^[7]	ADS _R ^[7]	Address Strobe Input. Used as an address qualifier. This signal should be asserted LOW for the part using the externally supplied address on the address pins and for loading this address into the burst address counter.
\overline{CE}_{0L} ^[7]	\overline{CE}_{0R} ^[7]	Active LOW Chip Enable Input.
CE _{1L} ^[8]	CE _{1R} ^[8]	Active HIGH Chip Enable Input.
CLK _L	CLK _R	Clock Signal. Maximum clock input rate is f _{MAX} .
CNTEN _L ^[7]	CNTEN _R ^[7]	Counter Enable Input. Asserting this signal LOW increments the burst address counter of its respective port on each rising edge of CLK. The increment is disabled if ADS or CNTRST are asserted LOW.
CNTRST _L ^[8]	CNTRST _R ^[8]	Counter Reset Input. Asserting this signal LOW resets to zero the unmasked portion of the burst address counter of its respective port. CNTRST is not disabled by asserting ADS or CNTEN.
CNT/MSK _L ^[8]	CNT/MSK _R ^[8]	Address Counter Mask Register Enable Input. Asserting this signal LOW enables access to the mask register. When tied HIGH, the mask register is not accessible and the address counter operations are enabled based on the status of the counter control signals.
DQ _{0L} –DQ _{17L}	DQ _{0R} –DQ _{17R}	Data Bus Input/Output.
OE _L	OE _R	Output Enable Input. This asynchronous signal must be asserted LOW to enable the DQ data pins during Read operations.
INT _L	INT _R	Mailbox Interrupt Flag Output. The mailbox permits communications between ports. The upper two memory locations are used for message passing. INT _L is asserted LOW when the right port writes to the mailbox location of the left port, and vice versa. An interrupt to a port is deasserted HIGH when it reads the contents of its mailbox.
CNTINT _L ^[9]	CNTINT _R ^[9]	Counter Interrupt Output. This pin is asserted LOW when the unmasked portion of the counter is incremented to all '1s'.
R/W _L	R/W _R	Read/Write Enable Input. Assert this pin LOW to write to, or HIGH to Read from the dual port memory array.
\overline{B}_{0L} – \overline{B}_{1L}	\overline{B}_{0R} – \overline{B}_{1R}	Byte Select Inputs. Asserting these signals enables Read and Write operations to the corresponding bytes of the memory array.
MRST		Master Reset Input. MRST is an asynchronous input signal and affects both ports. Asserting MRST LOW performs all of the reset functions as described in the text. A MRST operation is required at power up.
TMS		JTAG Test Mode Select Input. It controls the advance of JTAG TAP state machine. State machine transitions occur on the rising edge of TCK.
TDI		JTAG Test Data Input. Data on the TDI input is shifted serially into selected registers.
TCK		JTAG Test Clock Input.
TDO		JTAG Test Data Output. TDO transitions occur on the falling edge of TCK. TDO is normally three-stated except when captured data is shifted out of the JTAG TAP.
V _{SS}		Ground Inputs.
V _{DD}		Power Inputs.

Notes

6. CY7C0831AV has 17 address bits, CY7C0832AV has 18 address bits and CY7C0833V has 19 address bits.
7. These balls are not applicable for CY7C0833V device. They must be tied to VSS.
8. These balls are not applicable for CY7C0833V device. They must be tied to VDD.
9. These balls are not applicable for CY7C0833V device. They must not be connected.



Byte Select Operation

Control Pin	Effect
\overline{B}_0	DQ ₀₋₈ Byte Control
\overline{B}_1	DQ ₉₋₁₇ Byte Control

Master Reset

The FLE_x18 family devices undergo a complete reset by taking its \overline{MRST} input LOW. The \overline{MRST} input can switch asynchronously to the clocks. An \overline{MRST} initializes the internal burst counters to zero, and the counter mask registers to all ones (completely unmasked). \overline{MRST} also forces the Mailbox Interrupt (\overline{INT}) flags and the Counter Interrupt (\overline{CNTINT}) flags HIGH. \overline{MRST} must be performed on the FLE_x18 family devices after power up.

Mailbox Interrupts

The upper two memory locations may be used for message passing and permit communications between ports. Table 1 shows the interrupt operation for both ports of CY7C0833V. The highest memory location, 7FFFF is the mailbox for the right port and 7FFFE is the mailbox for the left port. Table 1 shows that to

set the \overline{INT}_R flag, a Write operation by the left port to address 7FFFF asserts \overline{INT}_R LOW. At least one byte has to be active for a Write to generate an interrupt. A valid Read of the 7FFFF location by the right port resets \overline{INT}_R HIGH. At least one byte must be active for a Read to reset the interrupt. When one port Writes to the other port's mailbox, the \overline{INT} of the port that the mailbox belongs to is asserted LOW. The \overline{INT} is reset when the owner (port) of the mailbox Reads the contents of the mailbox. The interrupt flag is set in a flow-through mode (that is, it follows the clock edge of the writing port). Also, the flag is reset in a flow-through mode (that is, it follows the clock edge of the reading port).

Each port can read the other port's mailbox without resetting the interrupt. And each port can write to its own mailbox without setting the interrupt. If an application does not require message passing, \overline{INT} pins should be left open.

Table 1. Interrupt Operation Example [10, 11, 12, 13, 14, 15]

Function	Left Port				Right Port			
	R/W _L	CE _L	A _{0L} -A _{18L}	\overline{INT}_L	R/W _R	CE _R	A _{0R} -A _{18R}	\overline{INT}_R
Set Right \overline{INT}_R Flag	L	L	3FFFF	X	X	X	X	L
Reset Right \overline{INT}_R Flag	X	X	X	X	H	L	3FFFF	H
Set Left \overline{INT}_L Flag	X	X	X	L	L	L	3FFFE	X
Reset Left \overline{INT}_L Flag	H	L	3FFFE	H	X	X	X	X
Set Right \overline{INT}_R Flag	L	L	3FFFF	X	X	X	X	L

Notes

- CY7C0831AV has 17 address bits, CY7C0832AV has 18 address bits and CY7C0833V has 19 address bits.
- CE is internal signal. CE = LOW if CE₀ = LOW and CE₁ = HIGH. For a single Read operation, CE only needs to be asserted once at the rising edge of the CLK and can be deasserted after that. Data is out after the following CLK edge and is three-stated after the next CLK edge.
- OE is "Don't Care" for mailbox operation.
- At least one of BE₀, BE₁ must be LOW.
- A_{18x} is a NC for CY7C0832AV, therefore the Interrupt Addresses are 3FFFF and 3FFFE. A_{18x} and A_{17x} are NC for CY7C0831AV, therefore the Interrupt addresses are 1FFFF and 1FFFE.
- "X" = "Don't Care," "H" = HIGH, "L" = LOW.
- CNTINT and CNTRST specs are guaranteed by design to operate properly at speed grade operating frequency when tied together.



Address Counter and Mask Register Operations

This section ^[17] describes the features only apply to 2-Mbit and 4-Mbit devices. It does not apply to 9 Mbit device. Each port of these devices has a programmable burst address counter. The burst counter contains three registers: a counter register, a mask register, and a mirror register.

The **counter register** contains the address used to access the RAM array. It is changed only by the Counter Load, Increment, Counter Reset, and by master reset (MRST) operations.

The **mask register** value affects the Increment and Counter Reset operations by preventing the corresponding bits of the counter register from changing. It also affects the counter interrupt output (CNTINT). The mask register is changed only by the Mask Load and Mask Reset operations and by the MRST. The mask register defines the counting range of the counter register. It divides the counter register into two regions: zero or more '0s' in the most significant bits define the masked region, one or more '1s' in the least significant bits define the unmasked region. Bit 0 may also be '0,' masking the least significant counter bit and causing the counter to increment by two instead of one.

The **mirror register** is used to reload the counter register on increment operations (see [Retransmit on page 10](#)). It always contains the value last loaded into the counter register, and is changed only by the Counter Load, and by the MRST instructions. [Table 2](#) summarizes the operation of these registers and the required input control signals. The MRST control signal is asynchronous. All the other control signals in [Table 2](#) (CNT/MSK, CNTRST, ADS, CNTEN) are synchronized to the port's CLK. All these counter and mask operations are independent of the port's chip enable inputs (CE0 and CE1).

Counter enable (CNTEN) inputs are provided to stall the operation of the address input and use the internal address generated by the internal counter for fast, interleaved memory applications. A port's burst counter is loaded when the port's address strobe (ADS) and CNTEN signals are LOW. When the port's CNTEN is asserted and the ADS is deasserted, the address counter increments on each LOW to HIGH transition of that port's clock signal. This reads and writes one word from and to each successive address location until CNTEN is deasserted. The counter can address the entire memory array, and loops back to the start. Counter reset (CNTRST) is used to reset the unmasked portion of the burst counter to I/0s. A counter-mask register is used to control the counter wrap.

Table 2. Address Counter and Counter-Mask Register Control Operation (Any Port) ^[18, 19]

CLK	MRST	CNT/MSK	CNTRST	ADS	CNTEN	Operation	Description
X	L	X	X	X	X	Master Reset	Reset address counter to all 0s and mask register to all 1s.
	H	H	L	X	X	Counter Reset	Reset counter unmasked portion to all 0s.
	H	H	H	L	L	Counter Load	Load counter with external address value presented on address lines.
	H	H	H	L	H	Counter Readback	Read out counter internal value on address lines.
	H	H	H	H	L	Counter Increment	Internally increment address counter value.
	H	H	H	H	H	Counter Hold	Constantly hold the address value for multiple clock cycles.
	H	L	L	X	X	Mask Reset	Reset mask register to all 1s.
	H	L	H	L	L	Mask Load	Load mask register with value presented on the address lines.
	H	L	H	L	H	Mask Readback	Read out mask register value on address lines.
	H	L	H	H	X	Reserved	Operation undefined

Notes

- 17. This section describes the CY7C0832AV and CY7C0831AV having 18 and 17 address bits.
- 18. "X" = "Don't Care," "H" = HIGH, "L" = LOW.
- 19. Counter operation and mask register operation is independent of chip enables.



Counter Reset Operation

All unmasked bits of the counter are reset to '0.' All masked bits remain unchanged. The mirror register is loaded with the value of the burst counter. A Mask Reset followed by a Counter Reset resets the counter and mirror registers to 00000, as does master reset (MRST).

Counter Load Operation

The address counter and mirror registers are both loaded with the address value presented at the address lines.

Counter Increment Operation

When the address counter register is initially loaded with an external address, the counter can internally increment the address value, potentially addressing the entire memory array. Only the unmasked bits of the counter register are incremented. The corresponding bit in the mask register must be a '1' for a counter bit to change. The counter register is incremented by 1 if the least significant bit is unmasked, and by 2 if it is masked. If all unmasked bits are '1,' the next increment wraps the counter back to the initially loaded value. If an Increment results in all the

unmasked bits of the counter being '1s,' a counter interrupt flag (CNTINT) is asserted. The next Increment returns the counter register to its initial value, which was stored in the mirror register. The counter address can instead be forced to loop to 00000 by externally connecting CNTINT to CNTRST.^[20] An increment that results in one or more of the unmasked bits of the counter being '0' deasserts the counter interrupt flag. The example in Figure 3 shows the counter mask register loaded with a mask value of 0003Fh unmasking the first 6 bits with bit '0' as the LSB and bit '16' as the MSB. The maximum value the mask register can be loaded with is 3FFFFh. Setting the mask register to this value allows the counter to access the entire memory space. The address counter is then loaded with an initial value of 8h. The base address bits (in this case, the 6th address through the 16th address) are loaded with an address value but do not increment after the counter is configured for increment operation. The counter address starts at address 8h. The counter increments its internal address value until it reaches the mask register value of 3Fh. The counter wraps around the memory block to location 8h at the next count. CNTINT is issued when the counter reaches its maximum value.

Figure 3. Programmable Counter-Mask Register Operation^[21, 22]

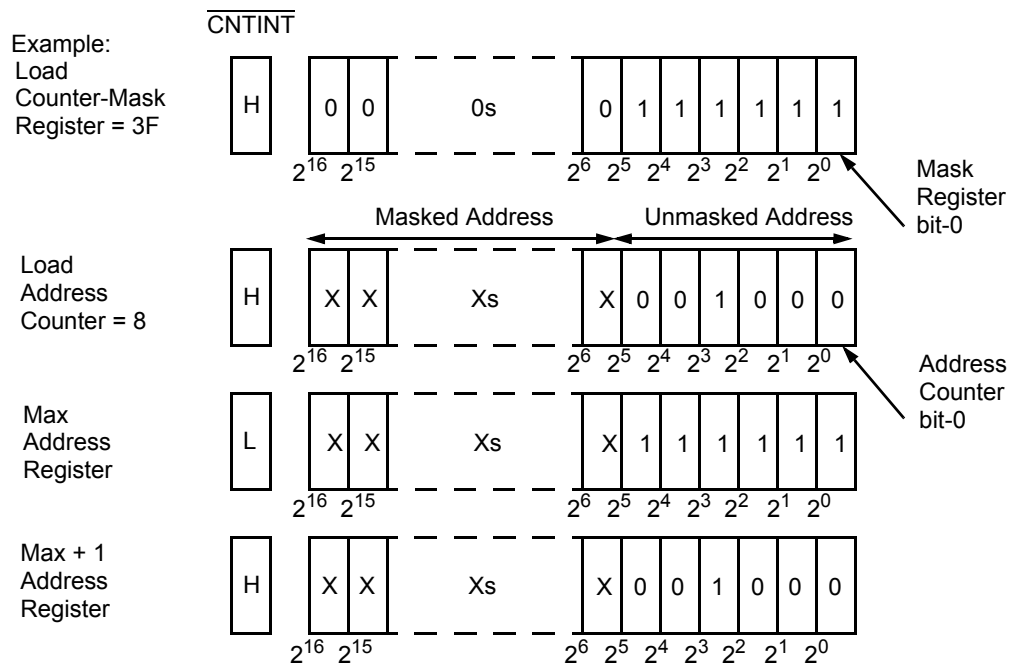

Notes

20. CNTINT and CNTRST specs are guaranteed by design to operate properly at speed grade operating frequency when tied together.
21. CY7C0831AV has 17 address bits, CY7C0832AV has 18 address bits and CY7C0833V has 19 address bits.
22. The "X" in this diagram represents the counter upper bits.

Counter Hold Operation

The value of all three registers can be constantly maintained unchanged for an unlimited number of clock cycles. Such operation is useful in applications where wait states are needed, or when address is available a few cycles ahead of data in a shared bus interface.

Counter Interrupt

The counter interrupt ($\overline{\text{CNTINT}}$) is asserted LOW when an increment operation results in the unmasked portion of the counter register being all '1s.' It is deasserted HIGH when an Increment operation results in any other value. It is also de-asserted by Counter Reset, Counter Load, Mask Reset and Mask Load operations, and by $\overline{\text{MRST}}$.

Counter Readback Operation

The internal value of the counter register can be read out on the address lines. Readback is pipelined; the address is valid $t_{\text{CA}2}$ after the next rising edge of the port's clock. If address readback occurs while the port is enabled ($\overline{\text{CE0}}$ LOW and CE1 HIGH), the data lines (DQs) are three-stated. [Figure 4 on page 11](#) shows a block diagram of the operation.

Retransmit

Retransmit is a feature that allows the Read of a block of memory more than once without the need to reload the initial address. This eliminates the need for external logic to store and route data. It also reduces the complexity of the system design and saves board space. An internal mirror register is used to store the initially loaded address counter value. When the counter unmasked portion reaches its maximum value set by the mask register, it wraps back to the initial value stored in this mirror register. If the counter is continuously configured in increment mode, it increments again to its maximum value and wraps back

to the value initially stored into the mirror register. Thus, the repeated access of the same data is allowed without the need for any external logic.

Mask Reset Operation

The mask register is reset to all '1s,' which unmask every bit of the counter. Master reset ($\overline{\text{MRST}}$) also resets the mask register to all '1s'.

Mask Load Operation

The mask register is loaded with the address value presented at the address lines. Not all values permit correct increment operations. Permitted values are of the form $2^n - 1$ or $2^n - 2$. From the most significant bit to the least significant bit, permitted values have zero or more '0s,' one or more '1s,' or one '0.' Thus 3FFFF, 003FE, and 00001 are permitted values, but 3F0FF, 003FC, and 00000 are not.

Mask Readback Operation

The internal value of the mask register can be read out on the address lines. Readback is pipelined; the address is valid $t_{\text{CM}2}$ after the next rising edge of the port's clock. If mask readback occurs while the port is enabled ($\overline{\text{CE0}}$ LOW and CE1 HIGH), the data lines (DQs) is three-stated. [Figure 4 on page 11](#) shows a block diagram of the operation.

Counting by Two

When the least significant bit of the mask register is '0,' the counter increments by two. This may be used to connect the $\times 18$ devices as a 36-bit single port SRAM in which the counter of one port counts even addresses and the counter of the other port counts odd addresses. This even-odd address scheme stores one half of the 36-bit data in even memory locations, and the other half in odd memory locations.

Figure 4. Counter, Mask, and Mirror Logic Block Diagram [23]

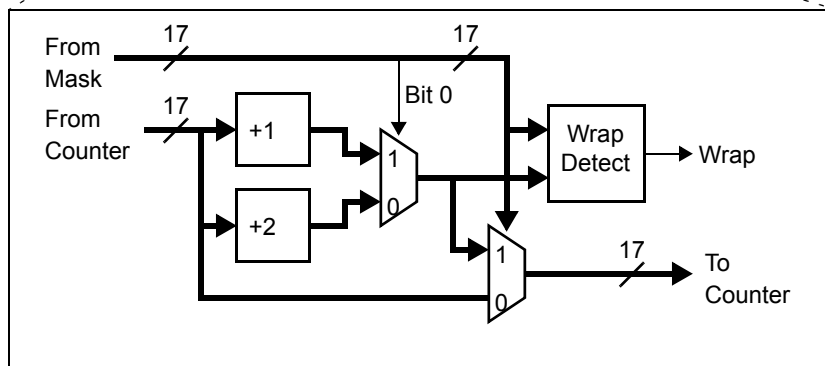
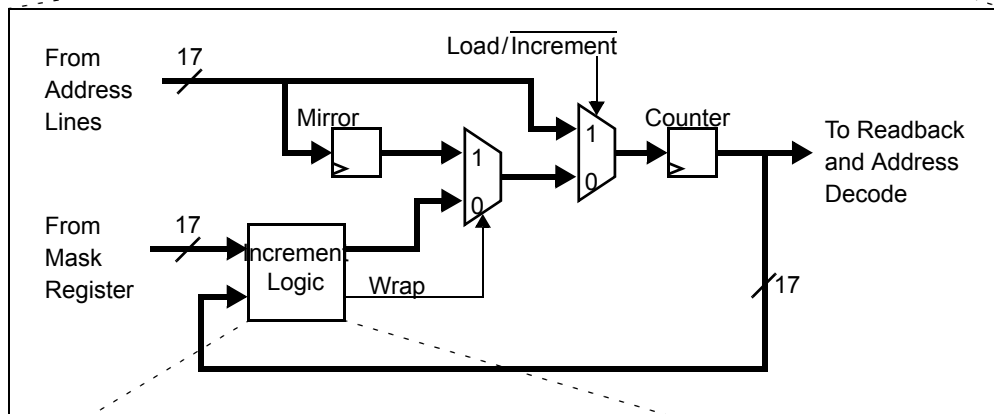
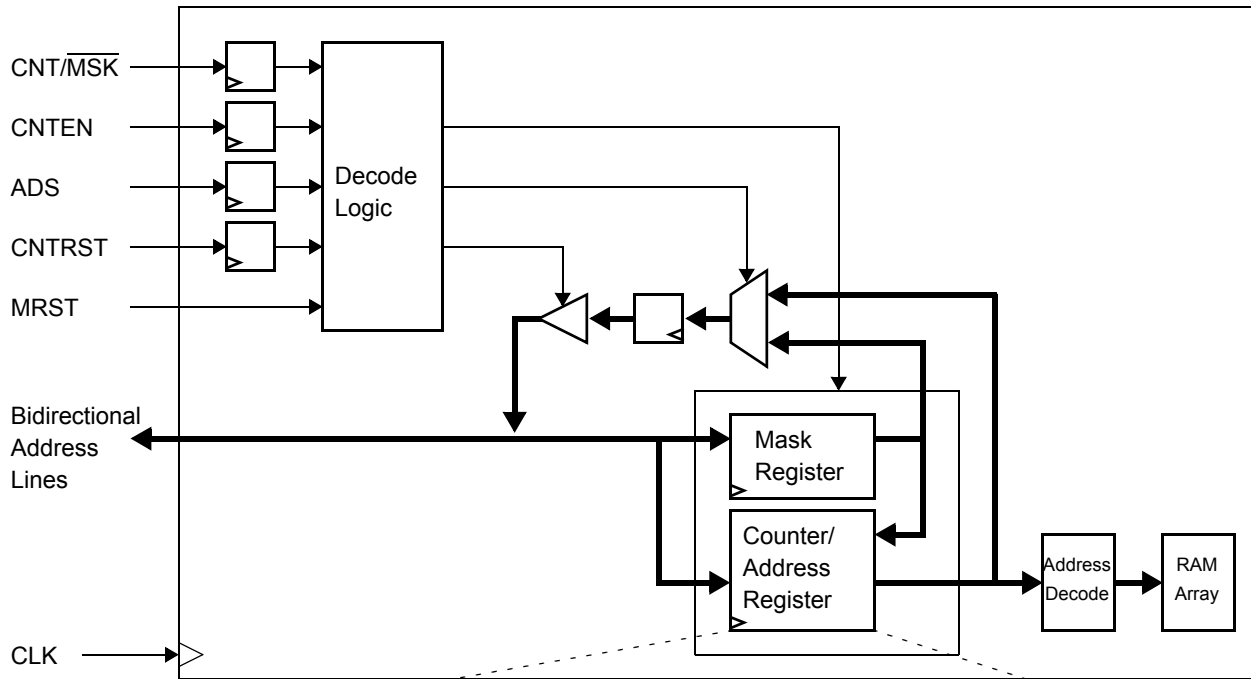

Note
23. CY7C0831AV has 17 address bits, CY7C0832AV has 18 address bits and CY7C0833V has 19 address bits.

IEEE 1149.1 Serial Boundary Scan (JTAG) [24]

The FLEx18 family devices incorporate an IEEE 1149.1 serial boundary scan test access port (TAP). The TAP controller functions in a manner that does not conflict with the operation of other devices using 1149.1 compliant TAPs. The TAP operates using JEDEC-standard 3.3 V I/O logic levels. It is composed of three input connections and one output connection required by the test logic defined by the standard.

Performing a TAP Reset

A reset is performed by forcing TMS HIGH (V_{DD}) for five rising edges of TCK. This reset does not affect the operation of the devices, and may be performed while the device is operating. An MRST must be performed on the devices after power up.

Performing a Pause/Restart

When a SHIFT-DR PAUSE-DR SHIFT-DR is performed the scan chain outputs the next bit in the chain twice. For example, if the value expected from the chain is 1010101, the device outputs a 11010101. This extra bit causes some testers to report an erroneous failure for the devices in a scan test. Therefore the tester should be configured to never enter the PAUSE-DR state.

Boundary Scan Hierarchy for 9-Mbit Device

Internally, the CY7C0833V have two DIEs. Each DIE contain all the circuitry required to support boundary scan testing. The circuitry includes the TAP, TAP controller, instruction register, and data registers. The circuitry and operation of the DIE boundary scan are described in detail below. The scan chain of each DIE are connected serially to form the scan chain of the CY7C0833V as shown in [Figure 5 on page 12](#). TMS and TCK are connected in parallel to each DIE to drive all TAP controllers in unison. In many cases, each DIE is supplied with the same instruction. In other cases, it might be useful to supply different instructions to each DIE. One example would be testing the device ID of one DIE while bypassing the others.

Each pin of FLEx18 family is typically connected to multiple DIEs. For connectivity testing with the EXTEST instruction, it is desirable to check the internal connections between DIEs and the external connections to the package. This is accomplished by merging the netlist of the devices with the netlist of the user's circuit board. To facilitate boundary scan testing of the devices, Cypress provides the BSDL file for each DIE, the internal netlist of the device, and a description of the device scan chain. The user can use these materials to easily integrate the devices into the board's boundary scan environment.

Figure 5. Scan Chain for 9 Mb Device

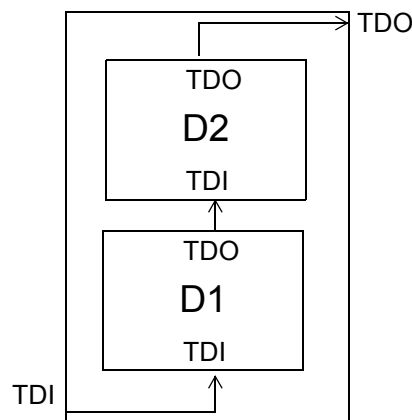

Note

24. Boundary scan is IEEE 1149.1-compatible. See [Performing a Pause/Restart on page 12](#) for deviation from strict 1149.1 compliance.

Identification Register Definitions

Instruction Field	Value	Description
Revision Number (31:28)	0h	Reserved for version number.
Cypress Device ID (27:12)	C090h	Defines Cypress part number for CY7C0832AV
	C091h	Defines Cypress part number for CY7C0831AV
Cypress JEDEC ID (11:1)	034h	Allows unique identification of the DP family device vendor.
ID Register Presence (0)	1	Indicates the presence of an ID register.

Scan Registers Sizes

Register Name	Bit Size
Instruction	4
Bypass	1
Identification	32
Boundary Scan	n ^[25]

Instruction Identification Codes

Instruction	Code	Description
EXTEST	0000	Captures the Input/Output ring contents. Places the BSR between the TDI and TDO.
BYPASS	1111	Places the BYR between TDI and TDO.
IDCODE	1011	Loads the IDR with the vendor ID code and places the register between TDI and TDO.
HIGHZ	0111	Places BYR between TDI and TDO. Forces all device output drivers to a High Z state.
CLAMP	0100	Controls boundary to 1/0. Places BYR between TDI and TDO.
SAMPLE/PRELOAD	1000	Captures the input/output ring contents. Places BSR between TDI and TDO.
NBSRST	1100	Resets the non-boundary scan logic. Places BYR between TDI and TDO.
RESERVED	All other codes	Other combinations are reserved. Do not use other than the above.

Note

25. See details in the device BSDL file.

Maximum Ratings

Exceeding maximum ratings ^[26] may impair the useful life of the device. These user guidelines are not tested.

Storage Temperature	-65 °C to +150 °C
Ambient Temperature with Power Applied	-55 °C to +125 °C
Supply Voltage to Ground Potential	-0.5 V to +4.6 V
DC Voltage Applied to Outputs in High Z State	-0.5 V to $V_{DD} + 0.5 V$
DC Input Voltage	-0.5 V to $V_{DD} + 0.5 V$ ^[27]

Output Current into Outputs (LOW)	20 mA
Static Discharge Voltage (JEDEC JESD22-A114-2000B)	> 2000V
Latch Up Current	> 200 mA

Operating Range

Range	Ambient Temperature	V_{DD}
Commercial	0 °C to +70 °C	3.3 V ± 165 mV
Industrial	-40 °C to +85 °C	3.3 V ± 165 mV

Electrical Characteristics

Over the Operating Range

Parameter	Description	-167			-133			-100			Unit	
		Min	Typ	Max	Min	Typ	Max	Min	Typ	Max		
V_{OH}	Output HIGH Voltage ($V_{DD} = \text{Min}$, $I_{OH} = -4.0 \text{ mA}$)	2.4	-	-	2.4	-	-	2.4	-	-	V	
V_{OL}	Output LOW Voltage ($V_{DD} = \text{Min}$, $I_{OL} = +4.0 \text{ mA}$)	-	-	0.4	-	-	0.4	-	-	0.4	V	
V_{IH}	Input HIGH Voltage	2.0	-	-	2.0	-	-	2.0	-	-	V	
V_{IL}	Input LOW Voltage	-	-	0.8	-	-	0.8	-	-	0.8	V	
I_{OZ}	Output Leakage Current	-10	-	10	-10	-	10	-10	-	10	μA	
I_{IX1}	Input Leakage Current Except TDI, TMS, $\overline{\text{MRST}}$	-10	-	10	-10	-	10	-10	-	10	μA	
I_{IX2}	Input Leakage Current TDI, TMS, $\overline{\text{MRST}}$	-0.1	-	1.0	-0.1	-	1.0	-0.1	-	1.0	mA	
I_{CC}	Operating Current for ($V_{DD} = \text{Max}$, $I_{OUT} = 0 \text{ mA}$), Outputs Disabled	CY7C0831AV/ CY7C0832AV	-	225	300	-	225	300	-	-	-	mA
		CY7C0833V	-	-	-	-	270	400	-	200	310	mA
I_{SB1} ^[28]	Standby Current (Both Ports TTL Level) CE_L and $CE_R \geq V_{IH}$, $f = f_{MAX}$	-	90	115	-	90	115	-	90	115	mA	
I_{SB2} ^[28]	Standby Current (One Port TTL Level) $CE_L CE_R \geq V_{IH}$, $f = f_{MAX}$	-	160	210	-	160	210	-	160	210	mA	
I_{SB3} ^[28]	Standby Current (Both Ports CMOS Level) CE_L and $CE_R \geq V_{DD} - 0.2 \text{ V}$, $f = 0$	-	55	75	-	55	75	-	55	75	mA	
I_{SB4} ^[28]	Standby Current (One Port CMOS Level) $CE_L CE_R \geq V_{IH}$, $f = f_{MAX}$	-	160	210	-	160	210	-	160	210	mA	
I_{SB5}	Operating Current ($V_{DD} = \text{Max}$, $I_{OUT} = 0 \text{ mA}$, $f = 0$) Outputs Disabled	-	-	-	-	70	100	-	70	100	mA	

Notes

26. The voltage on any input or I/O pin can not exceed the power pin during power up.

27. Pulse width < 20 ns.

28. I_{SB1} , I_{SB2} , I_{SB3} and I_{SB4} are not applicable for CY7C0833V because it can not be powered down by using chip enable pins.

Capacitance

Part Number	Parameter ^[29]	Description	Test Conditions	Max	Unit
CY7C0831AV CY7C0832AV	C_{IN}	Input Capacitance	$T_A = 25^\circ\text{C}$, $f = 1\text{ MHz}$, $V_{DD} = 3.3\text{ V}$	13	pF
	C_{OUT}	Output Capacitance		10	pF
CY7C0833V	C_{IN}	Input Capacitance		22	pF
	C_{OUT}	Output Capacitance		20	pF

AC Test Load and Waveforms

Figure 6. AC Test Load and Waveforms

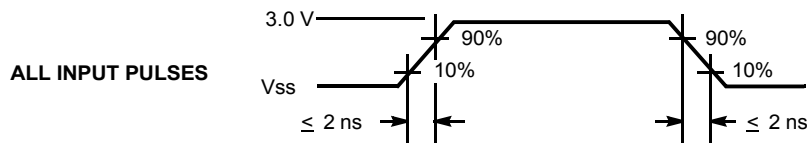
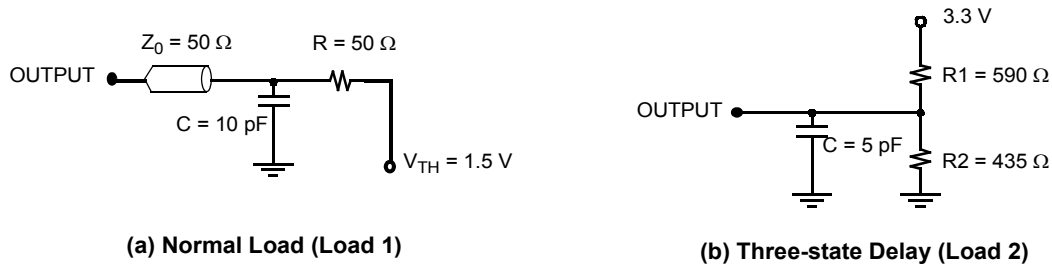

Note

29. C_{OUT} also references $C_{I/O}$.



Switching Characteristics

Over the Operating Range

Parameter	Description	-167		-133		-100		Unit
		CY7C0832AV		CY7C0831AV/ CY7C0832AV		CY7C0833V		
		Min	Max	Min	Max	Min	Max	
f_{MAX2}	Maximum Operating Frequency	–	167	–	133	–	100	MHz
t_{CYC2}	Clock Cycle Time	6.0	–	7.5	–	10	–	ns
t_{CH2}	Clock HIGH Time	2.7	–	3.0	–	4.0	–	ns
t_{CL2}	Clock LOW Time	2.7	–	3.0	–	4.0	–	ns
$t_R^{[30]}$	Clock Rise Time	–	2.0	–	2.0	–	3.0	ns
$t_F^{[30]}$	Clock Fall Time	–	2.0	–	2.0	–	3.0	ns
t_{SA}	Address Setup Time	2.3	–	2.5	–	3.0	–	ns
t_{HA}	Address Hold Time	0.6	–	0.6	–	0.6	–	ns
t_{SB}	Byte Select Setup Time	2.3	–	2.5	–	3.0	–	ns
t_{HB}	Byte Select Hold Time	0.6	–	0.6	–	0.6	–	ns
t_{SC}	Chip Enable Setup Time	2.3	–	2.5	–	NA	–	ns
t_{HC}	Chip Enable Hold Time	0.6	–	0.6	–	NA	–	ns
t_{SW}	R/\overline{W} Setup Time	2.3	–	2.5	–	3.0	–	ns
t_{HW}	R/\overline{W} Hold Time	0.6	–	0.6	–	0.6	–	ns
t_{SD}	Input Data Setup Time	2.3	–	2.5	–	3.0	–	ns
t_{HD}	Input Data Hold Time	0.6	–	0.6	–	0.6	–	ns
t_{SAD}	\overline{ADS} Setup Time	2.3	–	2.5	–	NA	–	ns
t_{HAD}	\overline{ADS} Hold Time	0.6	–	0.6	–	NA	–	ns
t_{SCN}	\overline{CNTEN} Setup Time	2.3	–	2.5	–	NA	–	ns
t_{HCN}	\overline{CNTEN} Hold Time	0.6	–	0.6	–	NA	–	ns
t_{SRST}	\overline{CNTNST} Setup Time	2.3	–	2.5	–	NA	–	ns

Note

30. Except JTAG signals (t_r and $t_f < 10$ ns [max.]).

Switching Characteristics *(continued)*

Over the Operating Range

Parameter	Description	-167		-133		-100		Unit
		CY7C0832AV		CY7C0831AV/ CY7C0832AV		CY7C0833V		
		Min	Max	Min	Max	Min	Max	
t _{HRST}	CNTRST Hold Time	0.6	–	0.6	–	NA	–	ns
t _{SCM}	CNT/MSK Setup Time	2.3	–	2.5	–	NA	–	ns
t _{HCM}	CNT/MSK Hold Time	0.6	–	0.6	–	NA	–	ns
t _{OE}	Output Enable to Data Valid	–	4.0	–	4.4	–	5.0	ns
t _{OLZ} ^[31, 32]	OE to Low Z	0	–	0	–	–	–	ns
t _{OHZ} ^[31, 32]	OE to High Z	0	4.0	0	4.4	–	5.0	ns
t _{CD2}	Clock to Data Valid	–	4.0	–	4.4	–	5.0	ns
t _{CA2}	Clock to Counter Address Valid	–	4.0	–	4.4	–	NA	ns
t _{CM2}	Clock to Mask Register Readback Valid	–	4.0	–	4.4	–	NA	ns
t _{DC}	Data Output Hold After Clock HIGH	1.0	–	1.0	–	1.0	–	ns
t _{CKHZ} ^[31, 32]	Clock HIGH to Output High Z	0	4.0	0	4.4	–	5.0	ns
t _{CKLZ} ^[31, 32]	Clock HIGH to Output Low Z	1.0	4.0	1.0	4.4	1.0	5.0	ns
t _{SINT}	Clock to INT Set Time	0.5	6.7	0.5	7.5	0.5	10	ns
t _{RINT}	Clock to INT Reset Time	0.5	6.7	0.5	7.5	0.5	10	ns
t _{SCINT}	Clock to CNTINT Set Time	0.5	5.0	0.5	5.7	NA	NA	ns
t _{RCINT}	Clock to CNTINT Reset time	0.5	5.0	0.5	5.7	NA	NA	ns
Port to Port Delays								
t _{CCS}	Clock to Clock Skew	5.2	–	6.0	–	8.0	–	ns
Master Reset Timing								
t _{RS}	Master Reset Pulse Width	7.0	–	7.5	–	10	–	ns
t _{RS}	Master Reset Setup Time	6.0	–	6.0	–	8.5	–	ns
t _{RSR}	Master Reset Recovery Time	6.0	–	7.5	–	10	–	ns
t _{RSF}	Master Reset to Outputs Inactive	–	10.0	–	10.0	–	10.0	ns
t _{RSCNTINT}	Master Reset to Counter Interrupt Flag Reset Time	–	10.0	–	10.0	–	NA	ns

Notes

31. This parameter is guaranteed by design, but is not production tested.
32. Test conditions used are Load 2.

Switching Waveforms

Figure 7. Master Reset

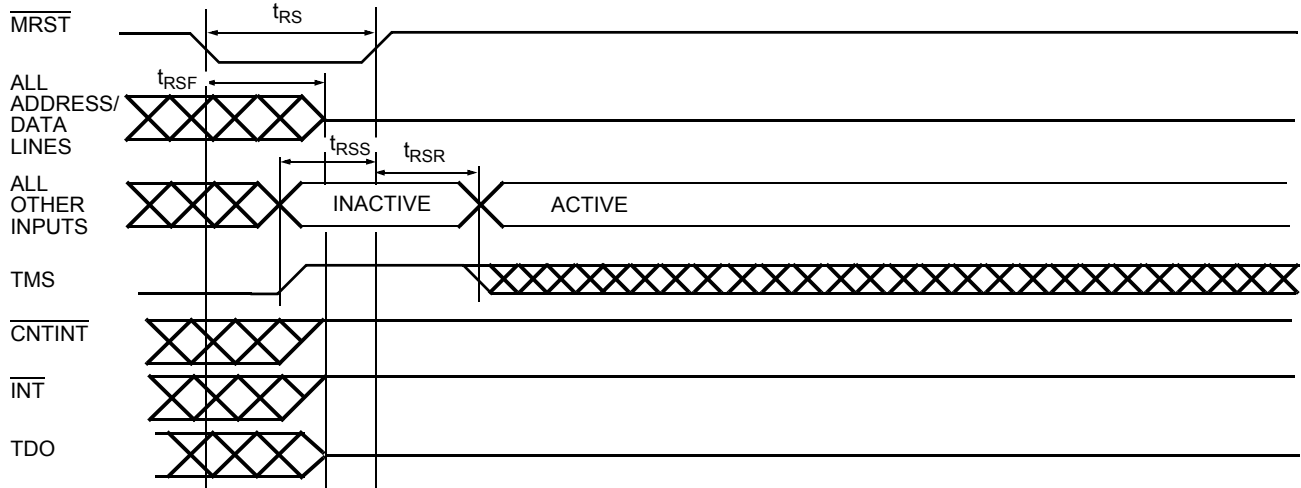
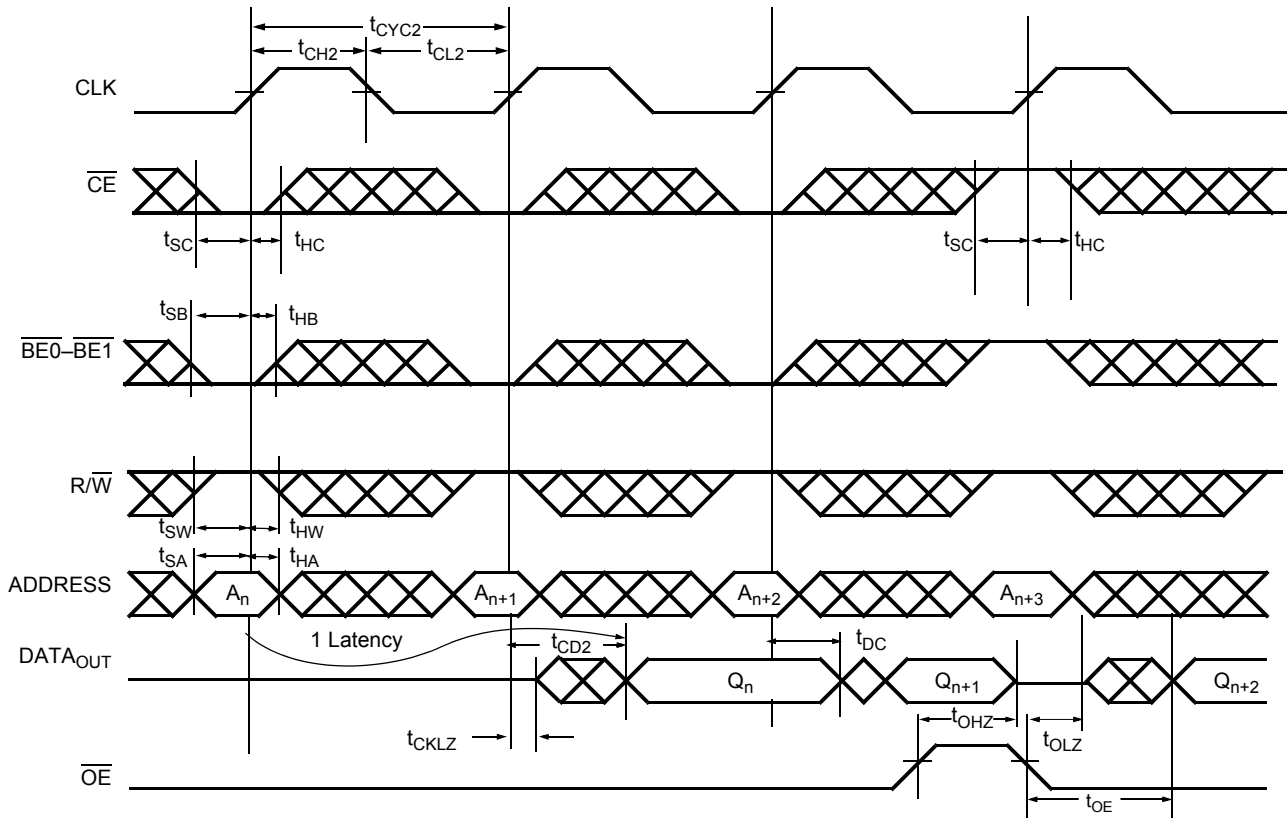

Figure 8. Read Cycle [33, 34, 35, 36, 37]



Notes

33. \overline{CE} is internal signal. $\overline{CE} = \text{LOW}$ if $\overline{CE}_0 = \text{LOW}$ and $CE_1 = \text{HIGH}$. For a single Read operation, \overline{CE} only needs to be asserted once at the rising edge of the CLK and can be deasserted after that. Data is out after the following CLK edge and is three-stated after the next CLK edge.
34. \overline{OE} is asynchronously controlled; all other inputs (excluding MRST and JTAG) are synchronous to the rising clock edge.
35. $ADS = CNTEN = \text{LOW}$, and $MRST = CNTRST = CNT/MSK = \text{HIGH}$.
36. The output is disabled (high-impedance state) by $CE = V_{IH}$ following the next rising edge of the clock.
37. Addresses need not be accessed sequentially because $ADS = CNTEN = V_{IL}$ with $CNT/MSK = V_{IH}$ constantly loads the address on the rising edge of the CLK. Numbers are for reference only.

Switching Waveforms (continued)

Figure 9. Bank Select Read [38, 39]

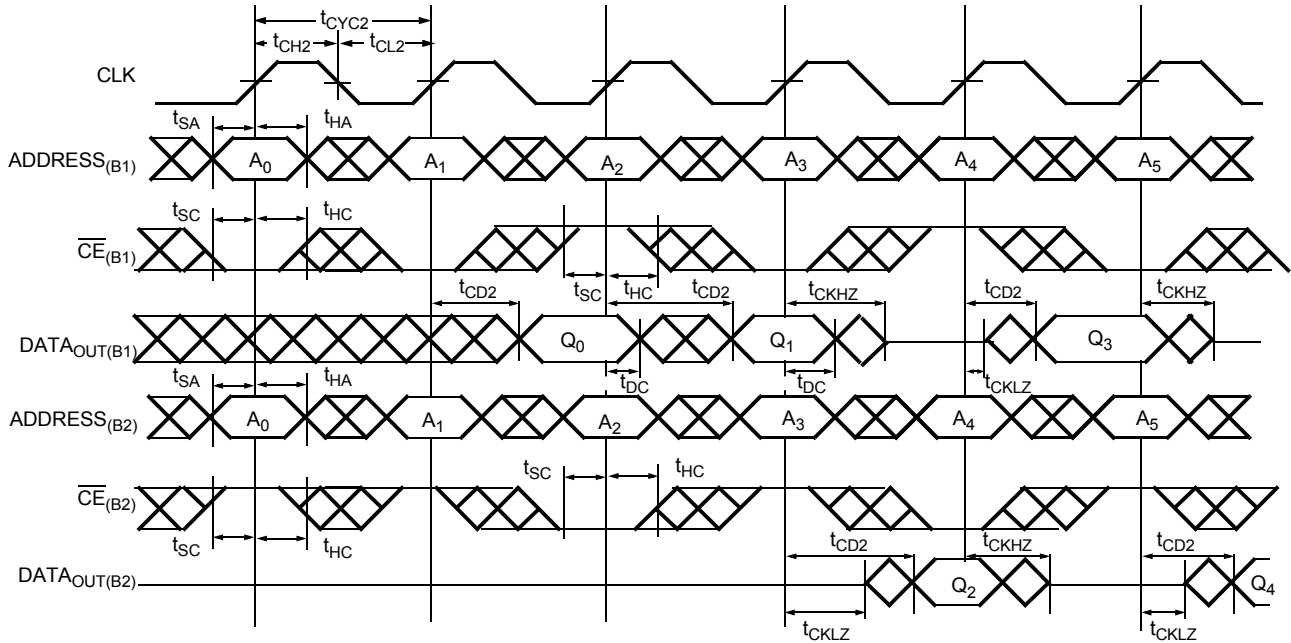
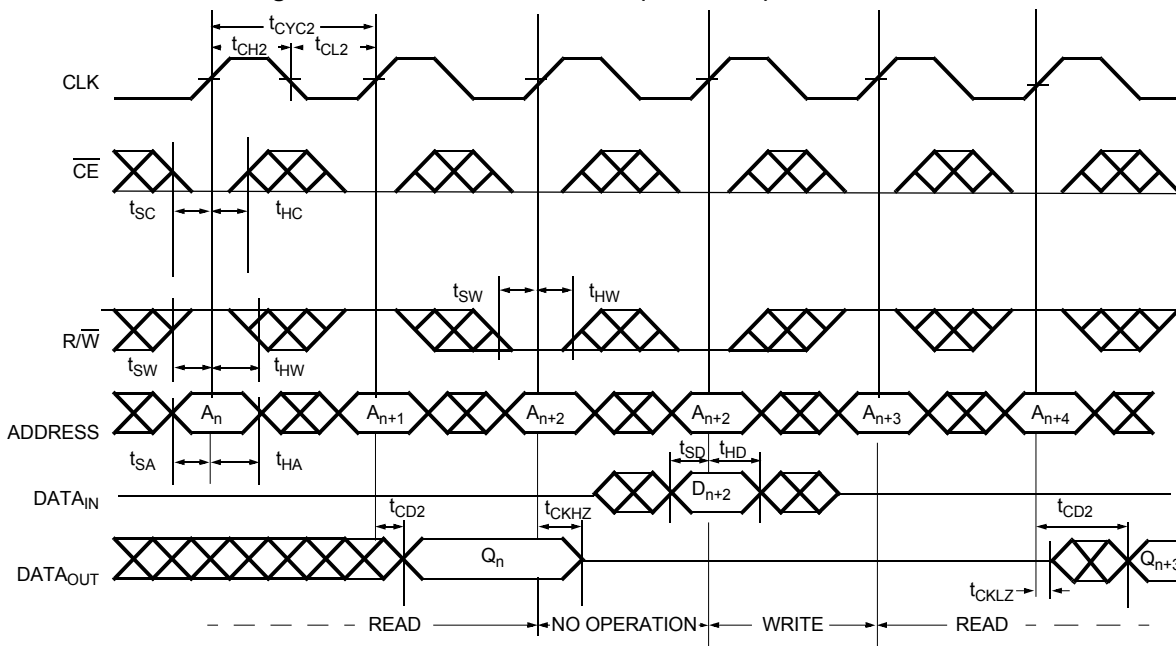

Figure 10. Read-to-Write-to-Read ($\overline{OE} = \text{LOW}$) [40, 41, 42, 43, 44]



Notes

- 38. In this depth-expansion example, B1 represents Bank #1 and B2 is Bank #2; each bank consists of one Cypress FLEx18 device from this data sheet. ADDRESS_(B1) = ADDRESS_(B2).
- 39. ADS = CNTEN = BE₀ - BE₁ = OE = LOW; MRST = CNTRST = CNT/MSK = HIGH.
- 40. Addresses need not be accessed sequentially because ADS = CNTEN = V_{IL} with CNT/MSK = V_{IH} constantly loads the address on the rising edge of the CLK. Numbers are for reference only.
- 41. Output state (HIGH, LOW, or high-impedance) is determined by the previous cycle control signals.
- 42. During "No Operation," data in memory at the selected address may be corrupted and should be rewritten to ensure data integrity.
- 43. CE₀ = OE = BE₀ - BE₁ = LOW; CE₁ = R/W = CNTRST = MRST = HIGH.
- 44. CE₀ = BE₀ - BE₁ = R/W = LOW; CE₁ = CNTRST = MRST = CNT/MSK = HIGH. When R/W first switches low, because OE = LOW, the Write operation cannot be completed (labelled as no operation). One clock cycle is required to three-state the I/O for the Write operation on the next rising edge of CLK.

Switching Waveforms (continued)

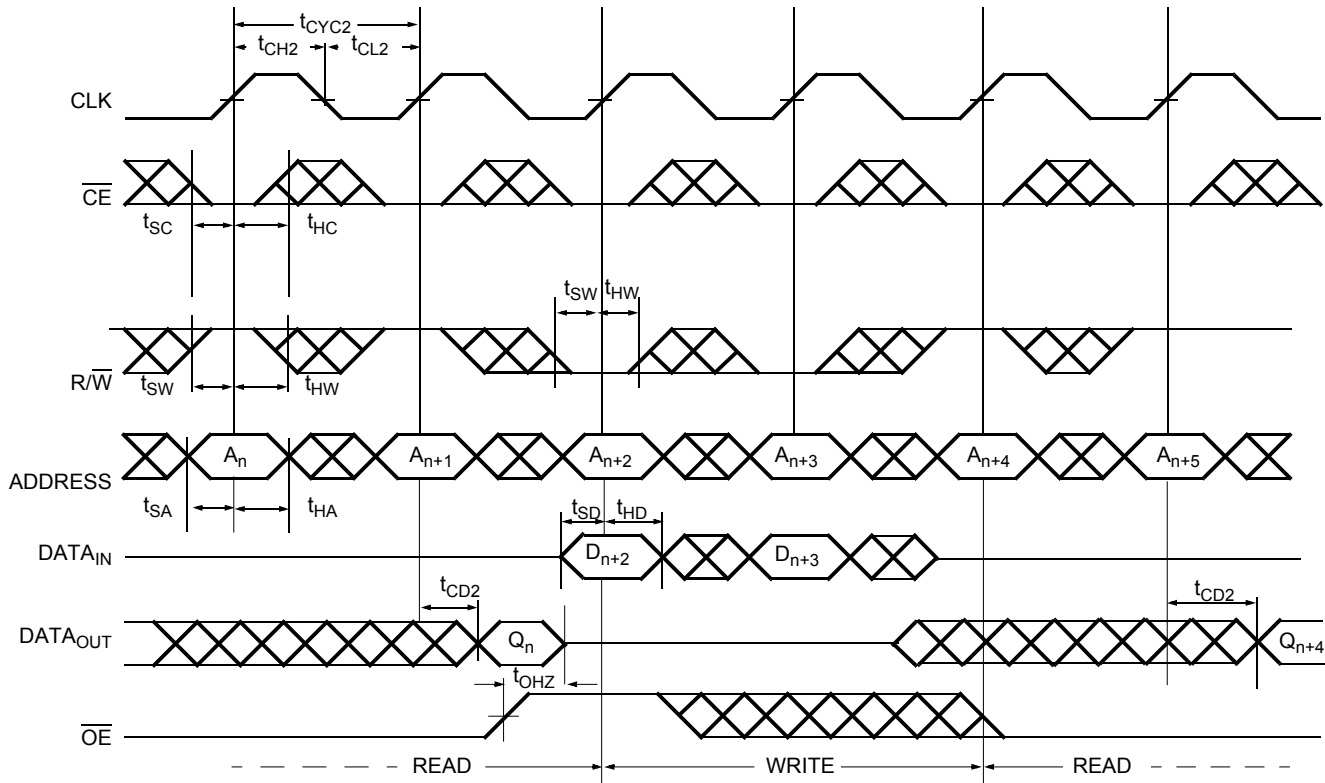
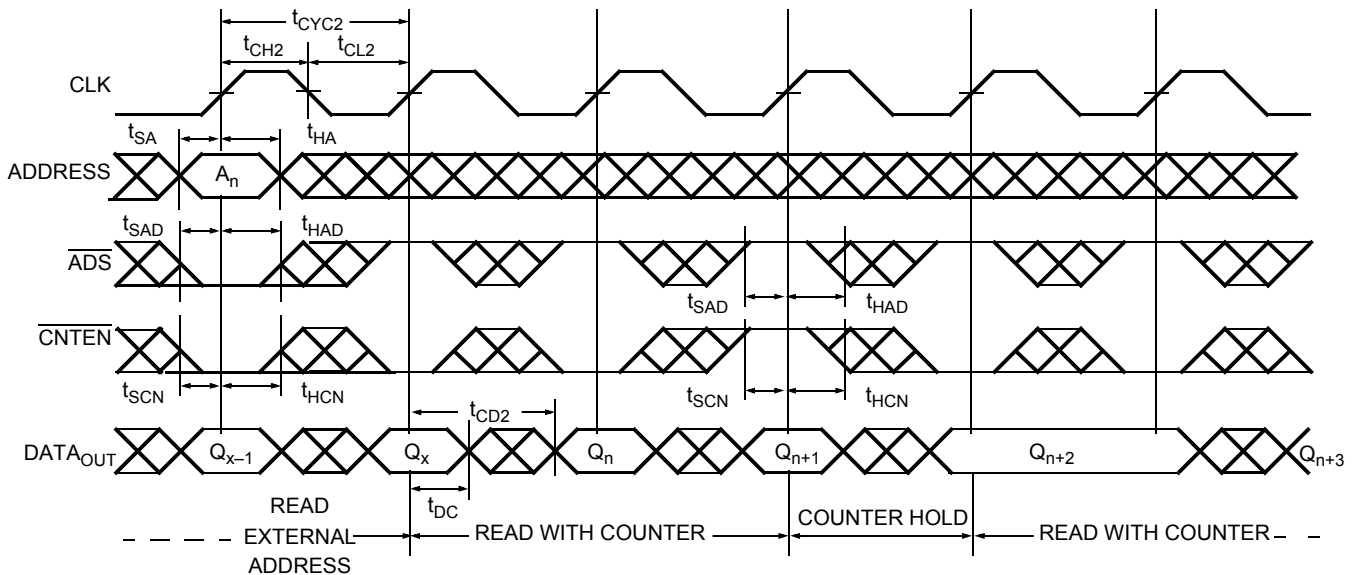
Figure 11. Read-to-Write-to-Read ($\overline{\text{OE}}$ Controlled) [45, 46, 47, 48]

Figure 12. Read with Address Counter Advance [47]

Notes

45. Addresses need not be accessed sequentially because $\overline{\text{ADS}} = \overline{\text{CNTEN}} = V_{\text{IL}}$ with $\text{CNT}/\overline{\text{MSK}} = V_{\text{IH}}$ constantly loads the address on the rising edge of the CLK. Numbers are for reference only.

46. Output state (HIGH, LOW, or high-impedance) is determined by the previous cycle control signals.

47. $\overline{\text{CE}}_0 = \overline{\text{OE}} = \overline{\text{BE}}_0 - \overline{\text{BE}}_1 = \text{LOW}$; $\text{CE}_1 = \text{R}/\overline{\text{W}} = \text{CNT}/\overline{\text{RST}} = \text{MRST} = \text{HIGH}$.

48. $\overline{\text{CE}}_0 = \overline{\text{BE}}_0 - \overline{\text{BE}}_1 = \text{R}/\overline{\text{W}} = \text{LOW}$; $\text{CE}_1 = \text{CNT}/\overline{\text{RST}} = \text{MRST} = \text{CNT}/\overline{\text{MSK}} = \text{HIGH}$. When $\text{R}/\overline{\text{W}}$ first switches low, because $\text{OE} = \text{LOW}$, the Write operation cannot be completed (labelled as no operation). One clock cycle is required to three-state the I/O for the Write operation on the next rising edge of CLK.

Switching Waveforms (continued)

Figure 13. Write with Address Counter Advance [49]

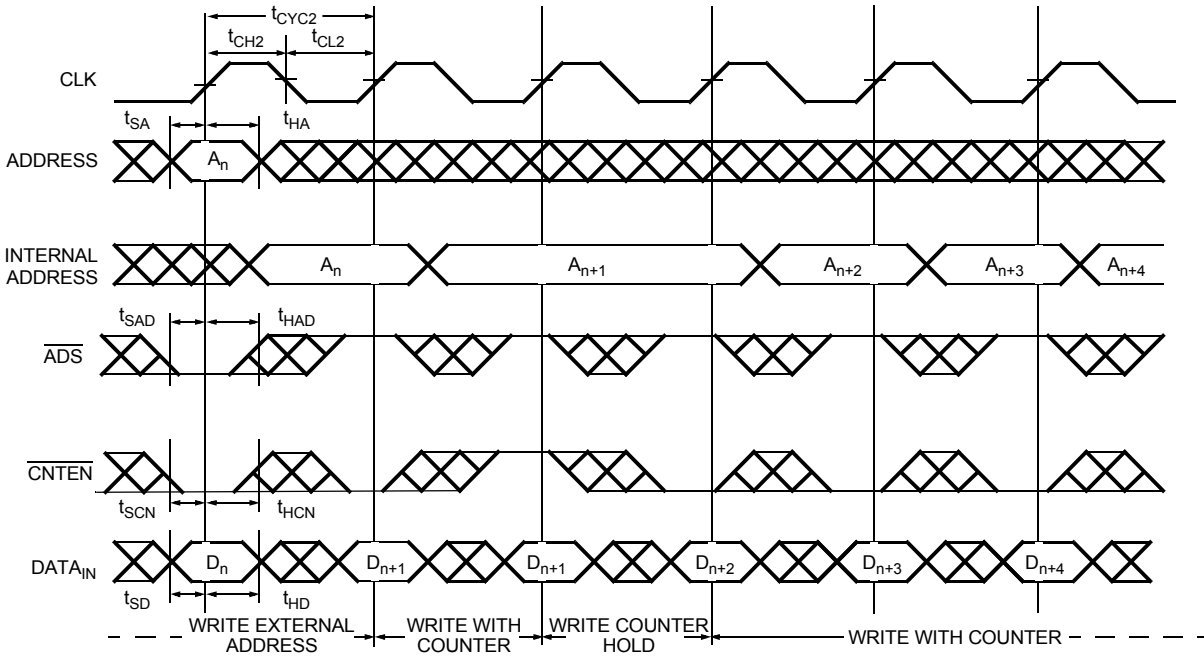
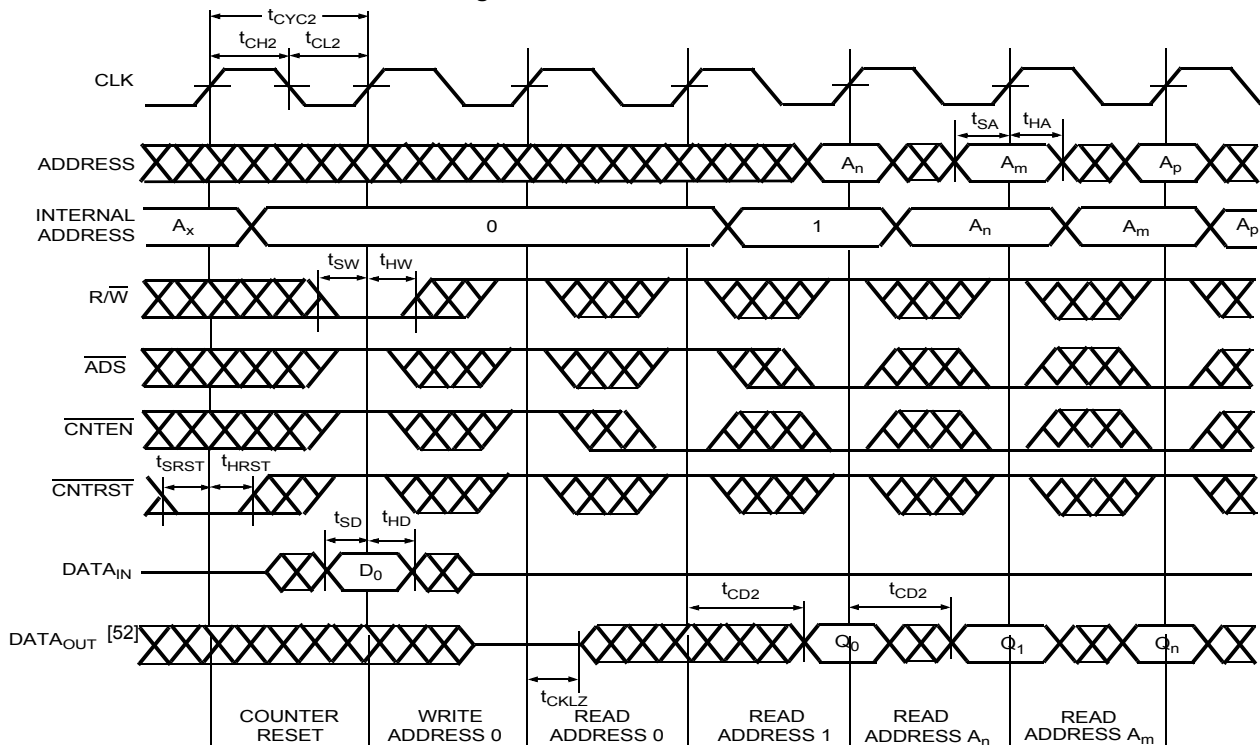

Figure 14. Counter Reset [50, 51]



Notes

- 49. $\overline{CE_0} = \overline{BE0} - \overline{BE1} = \overline{R/W} = \text{LOW}$; $CE_1 = \overline{CNTRST} = \overline{MRST} = \overline{CNT/MSK} = \text{HIGH}$. When $\overline{R/W}$ first switches low, because $OE = \text{LOW}$, the Write operation cannot be completed (labelled as no operation). One clock cycle is required to three-state the I/O for the Write operation on the next rising edge of CLK.
- 50. $\overline{CE_0} = \overline{BE0} - \overline{BE1} = \text{LOW}$; $CE_1 = \overline{MRST} = \overline{CNT/MSK} = \text{HIGH}$.
- 51. No dead cycle exists during counter reset. A Read or Write cycle may be coincidental with the counter reset.
- 52. Retransmit happens if the counter remains in increment mode after it wraps to initially loaded value.

Switching Waveforms (continued)

Figure 15. Readback State of Address Counter or Mask Register [53, 54, 55, 56]

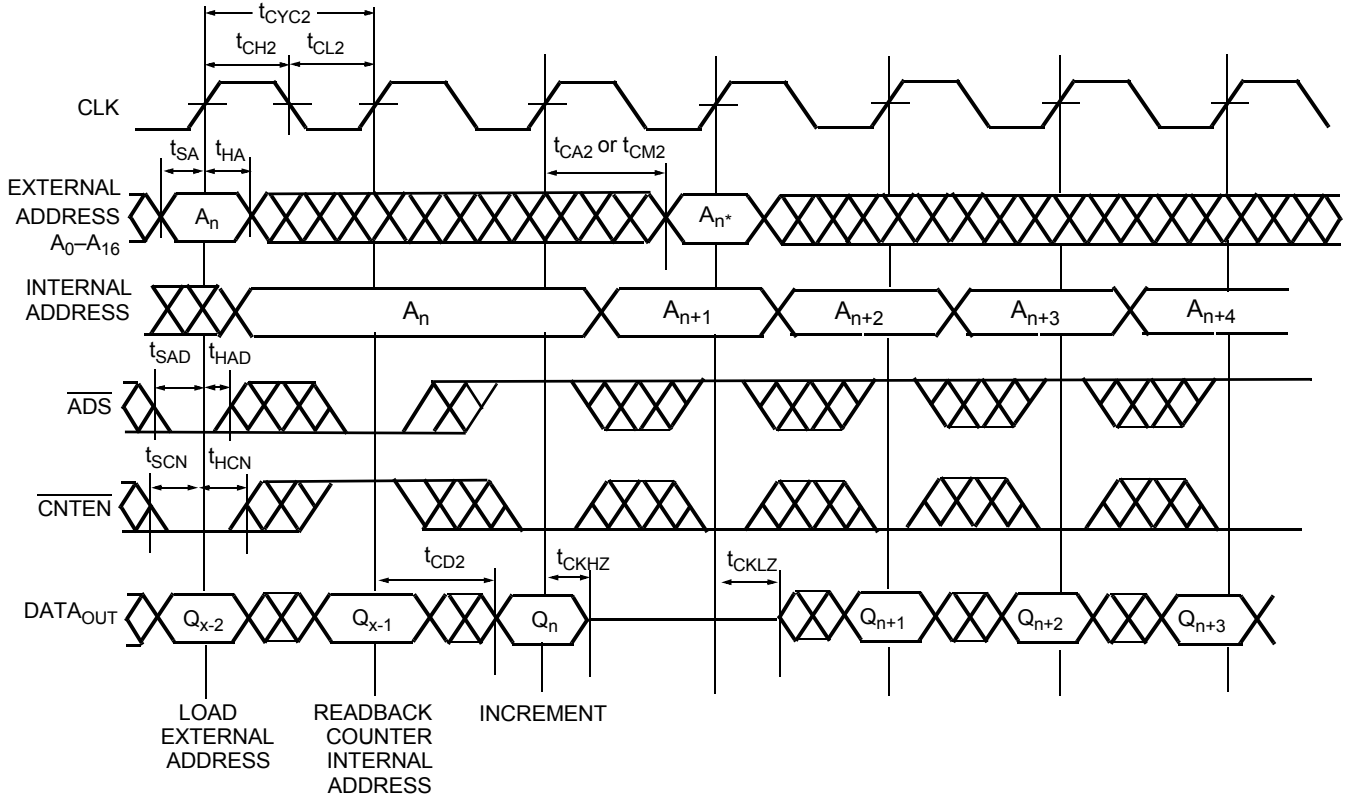

Notes

- 53. $\overline{CE}_0 = \overline{OE} = \overline{BE}_0 - \overline{BE}_1 = \text{LOW}$; $CE_1 = R/\overline{W} = \overline{CNT/MSK} = \overline{MRST} = \text{HIGH}$.
- 54. Address in output mode. Host must not be driving address bus after t_{CKLZ} in next clock cycle.
- 55. Address in input mode. Host can drive address bus after t_{CKHZ}.
- 56. A_n * is the internal value of the address counter (or the mask register depending on the CNT/MSK level) being Read out on the address lines.

Switching Waveforms (continued)

Figure 16. Left_Port (L_Port) Write to Right_Port (R_Port) Read [57, 58, 59]

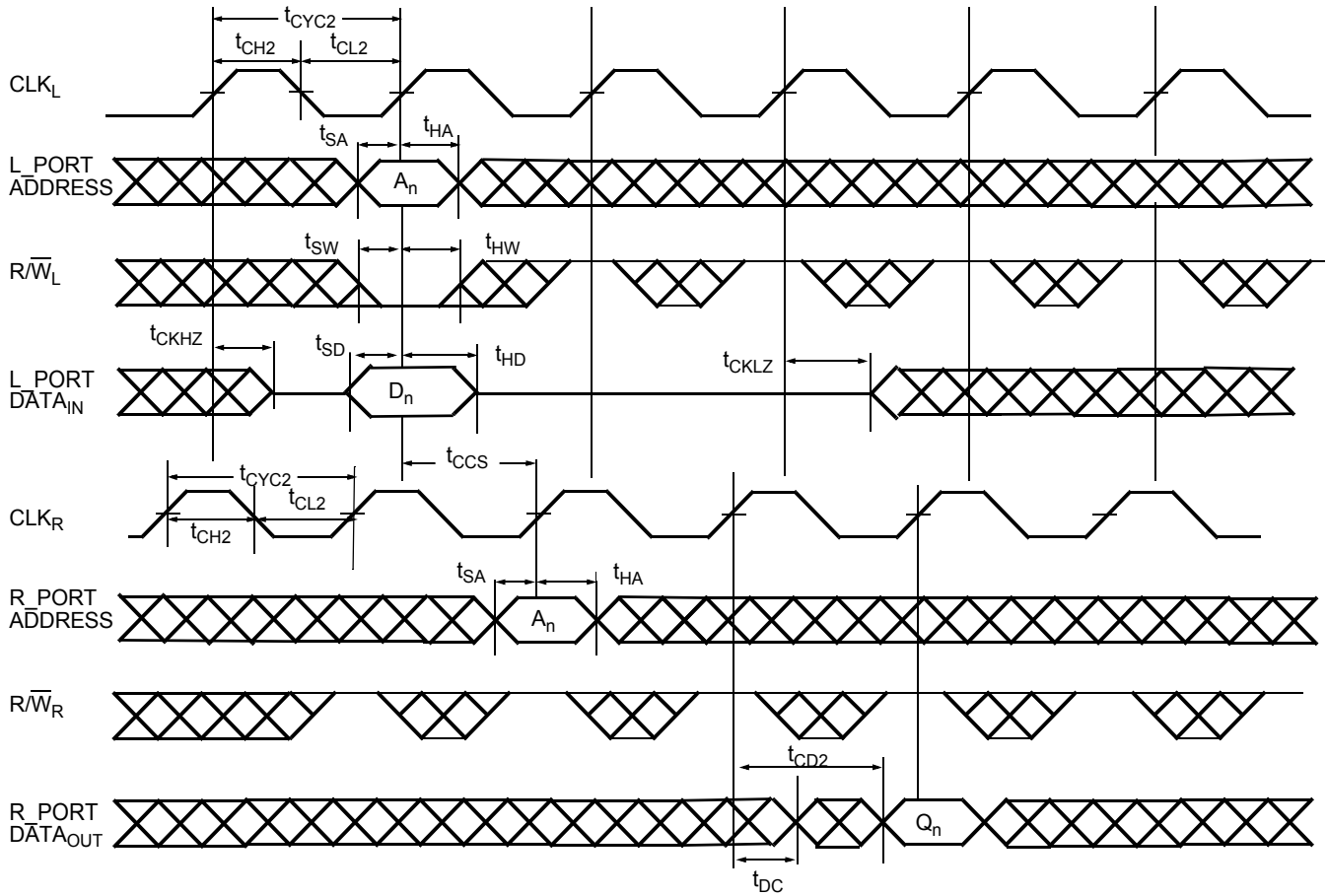

Notes

57. $\overline{CE}_0 = \overline{OE} = \overline{ADS} = \overline{CNTEN} = \overline{BE}_0 - \overline{BE}_1 = \text{LOW}$; $CE_1 = \overline{CNTRST} = \overline{MRST} = \overline{CNT/MSK} = \text{HIGH}$.

58. This timing is valid when one port is writing, and other port is reading the same location at the same time. If t_{CCS} is violated, indeterminate data is Read out.

59. If $t_{CCS} < \text{minimum specified value}$, then R_Port is Read the most recent data (written by L_Port) only ($2 * t_{CYC2} + t_{CD2}$) after the rising edge of R_Port's clock. If $t_{CCS} \geq \text{minimum specified value}$, then R_Port is Read the most recent data (written by L_Port) ($t_{CYC2} + t_{CD2}$) after the rising edge of R_Port's clock.

Switching Waveforms (continued)

Figure 17. Counter Interrupt and Retransmit [60, 61, 62, 63, 64, 65]

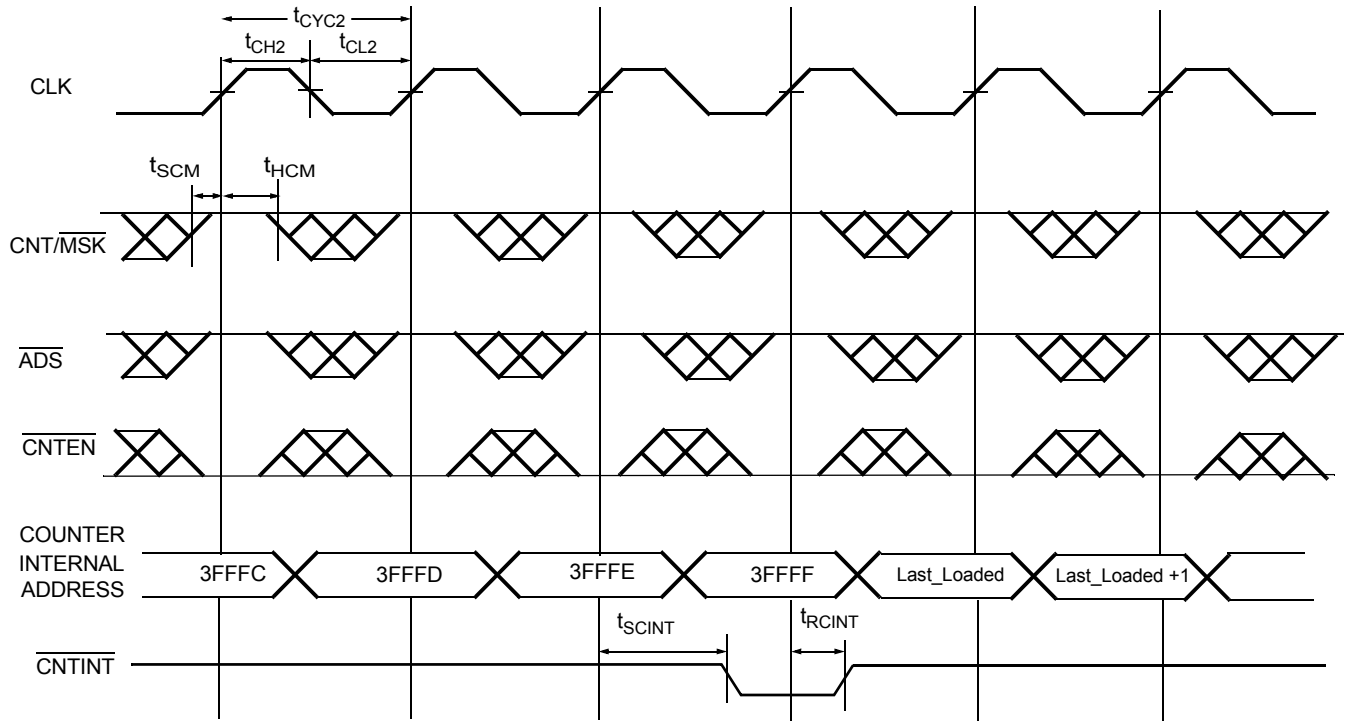

Notes

- 60. A18x is a NC for CY7C0832AV, therefore the Interrupt Addresses are 3FFFF and 3FFFE. A18x and A17x are NC for CY7C0831AV, therefore the Interrupt addresses are 1FFFF and 1FFFE.
- 61. Retransmit happens if the counter remains in increment mode after it wraps to initially loaded value.
- 62. $CE_0 = OE = BE_0 - BE_1 = LOW$; $CE_1 = R/W = CNTRST = MRST = HIGH$.
- 63. CNTINT is always driven.
- 64. CNTINT goes LOW when the unmasked portion of the address counter is incremented to the maximum value.
- 65. The mask register assumed to have the value of 3FFFFh.

Switching Waveforms (continued)

Figure 18. MailBox Interrupt Timing [66, 67, 68, 69, 70]

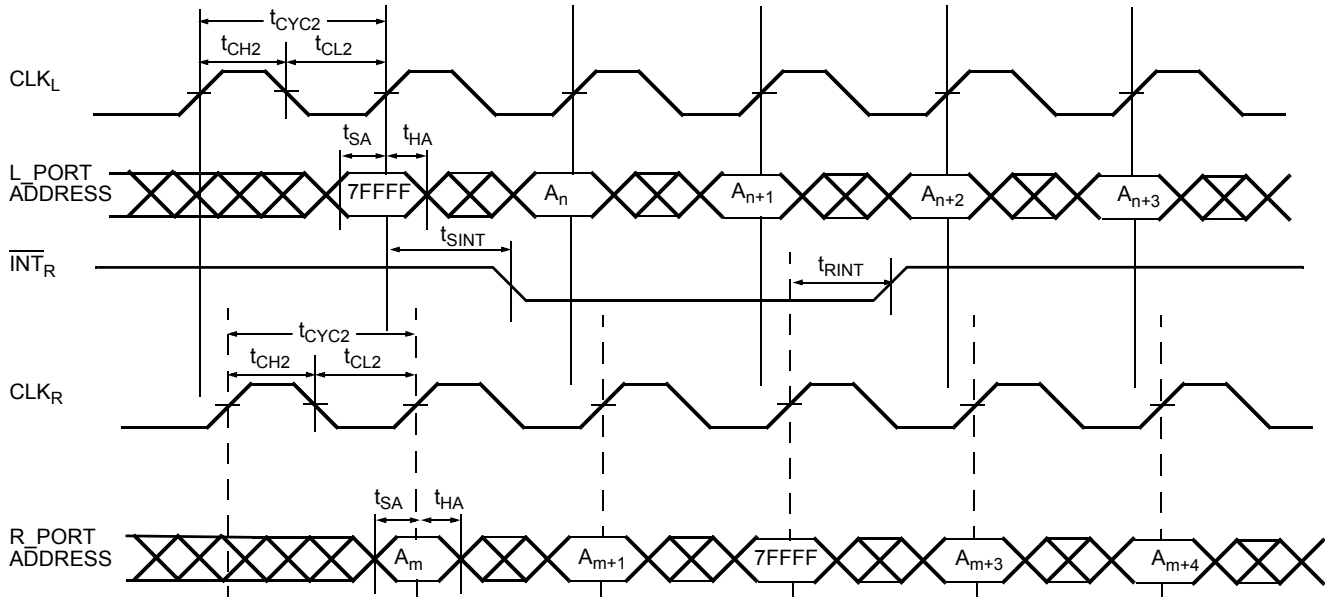

Notes

- 66. $\overline{CE}_0 = \overline{OE} = \overline{ADS} = \overline{CNTEN} = \text{LOW}$; $\overline{CE}_1 = \overline{CNTRST} = \overline{MRST} = \overline{CNT/MSK} = \text{HIGH}$.
- 67. Address "7FFFF" is the mailbox location for R_Port of the 9Mb device.
- 68. L_Port is configured for Write operation, and R_Port is configured for Read operation.
- 69. At least one byte enable ($\overline{BE}_0 - \overline{BE}_1$) is required to be active during interrupt operations.
- 70. Interrupt flag is set with respect to the rising edge of the Write clock, and is reset with respect to the rising edge of the Read clock.



JTAG Timing and Switching Characteristics

Parameter	Description	CY7C0831AV/CY7C0832AV /CY7C0833V		Unit
		Min	Max	
f_{JTAG}	Maximum JTAG TAP Controller Frequency	–	10	MHz
t_{TCYC}	TCK Clock Cycle Time	100	–	ns
t_{TH}	TCK Clock HIGH Time	40	–	ns
t_{TL}	TCK Clock LOW Time	40	–	ns
t_{TMSS}	TMS Setup to TCK Clock Rise	10	–	ns
t_{TMSH}	TMS Hold After TCK Clock Rise	10	–	ns
t_{TDIS}	TDI Setup to TCK Clock Rise	10	–	ns
t_{TDIH}	TDI Hold After TCK Clock Rise	10	–	ns
t_{TDOV}	TCK Clock LOW to TDO Valid	–	30	ns
t_{TDOX}	TCK Clock LOW to TDO Invalid	0	–	ns

JTAG Switching Waveforms

Figure 19. JTAG Switching Waveform

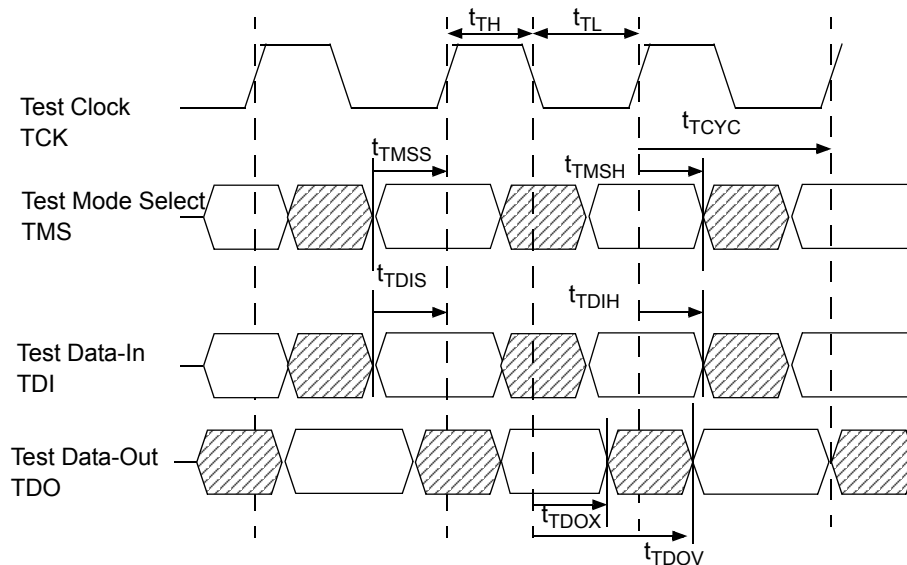



Read/Write and Enable Operation

Table 3. Read/Write and Enable Operation (Any Port) [71, 72, 73, 74, 75]

Inputs					Outputs	Operation
OE	CLK	CE ₀	CE ₁	R/W	DQ ₀ –DQ ₁₇	
X		H	X	X	High Z	Deselected
X		X	L	X	High Z	Deselected
X		L	H	L	D _{IN}	Write
L		L	H	H	D _{OUT}	Read
H	X	L	H	X	High Z	Outputs Disabled

Notes

71. CY7C0831AV has 17 address bits, CY7C0832AV has 18 address bits and CY7C0833V has 19 address bits.

72. "X" = "Don't Care," "H" = HIGH, "L" = LOW.

73. OE is an asynchronous input signal.

74. When CE changes state, deselection and Read happen after one cycle of latency.

75. CE₀ = OE = LOW; CE₁ = R/W = HIGH.

Ordering Information

Cypress offers other versions of this type of product in many different configurations and features. The following table contains only the list of parts that are currently available. For a complete listing of all options, visit the Cypress website at <http://www.cypress.com> and refer to the product summary page at <http://www.cypress.com/products> or contact your local sales representative.

Cypress maintains a worldwide network of offices, solution centers, manufacturer's representatives and distributors. To find the office closest to you, visit us at <http://www.cypress.com/go/datasheet/offices>.

512K × 18 (9M) 3.3 V Synchronous CY7C0833V Dual-Port SRAM

Speed (MHz)	Ordering Code	Package Diagram	Package Type	Operating Range
100	CY7C0833V-100BBI	51-85141	144-ball Ball Grid Array (13 × 13 × 1.6 mm) with 1 mm pitch	Industrial

256K × 18 (4M) 3.3 V Synchronous CY7C0832AV Dual-Port SRAM

Speed (MHz)	Ordering Code	Package Diagram	Package Type	Operating Range
167	CY7C0832AV-167AXC	51-85100	120-pin Thin Quad Flat Pack (14 × 14 × 1.4 mm) (Pb-free)	Commercial
133	CY7C0832AV-133AXI	51-85100	120-pin Thin Quad Flat Pack (14 × 14 × 1.4 mm) (Pb-free)	Industrial

128K × 18 (2M) 3.3 V Synchronous CY7C0831AV Dual-Port SRAM

Speed (MHz)	Ordering Code	Package Diagram	Package Type	Operating Range
133	CY7C0831AV-133AXI	51-85100	120-pin Thin Quad Flat Pack (14 × 14 × 1.4 mm) (Pb-free)	Industrial

Ordering Code Definitions

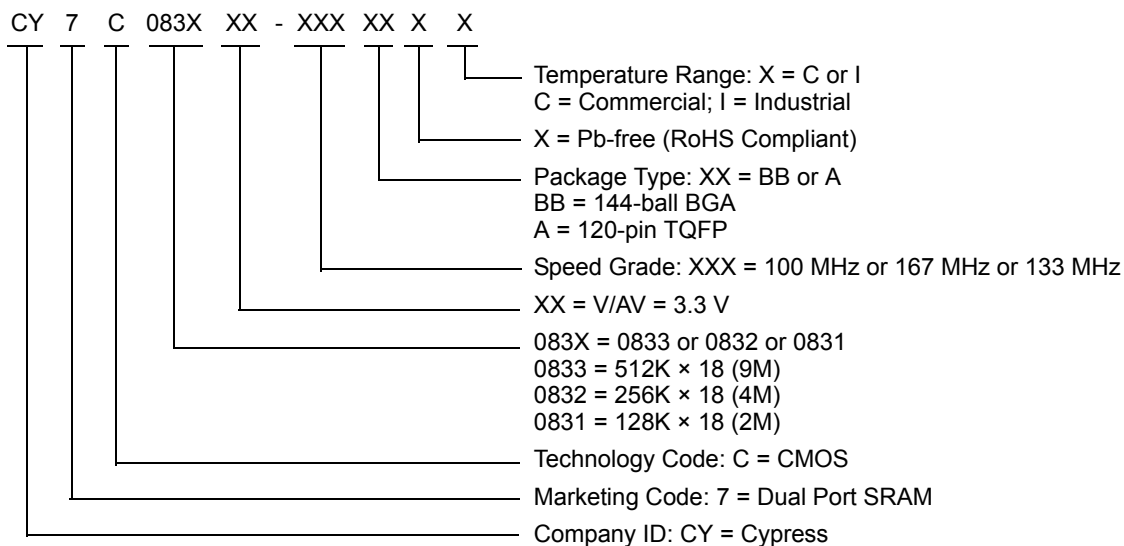

Package Diagrams

Figure 20. 144-ball FBGA (13 × 13 × 1.6 mm) BB144 Package Outline, 51-85141

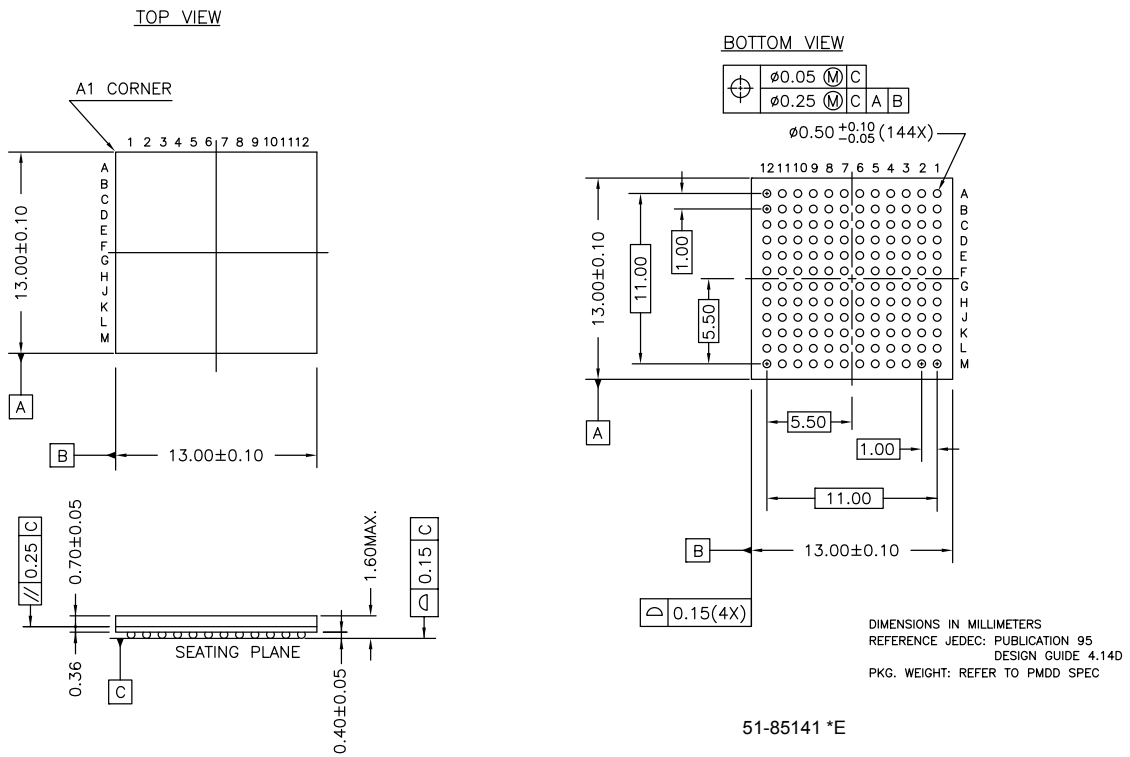
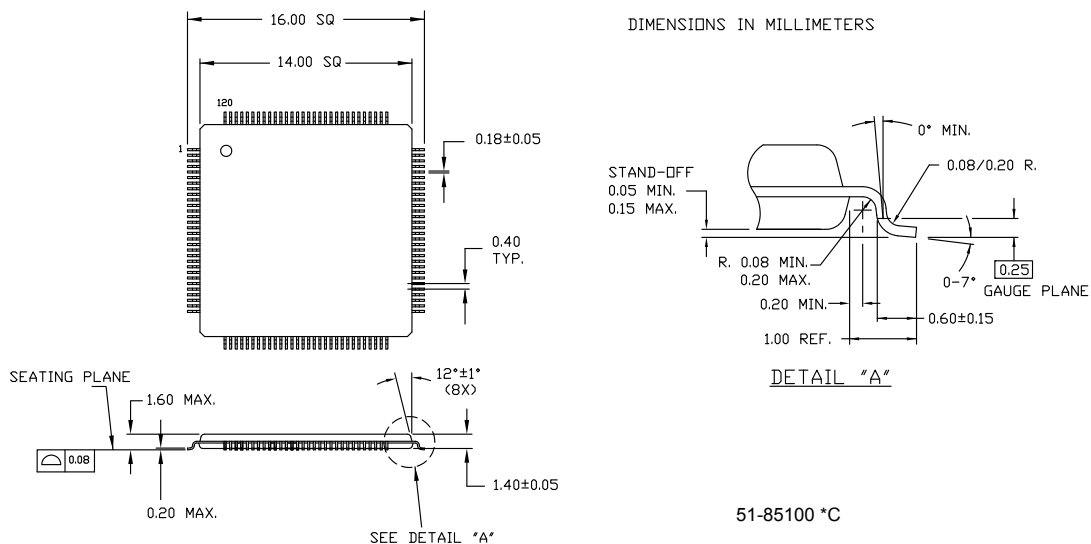

Figure 21. 120-pin TQFP (14 × 14 × 1.4 mm) A120S Package Outline, 51-85100





Acronyms

Acronym	Description
BGA	Ball Grid Array
\overline{CE}	Chip Enable
CMOS	Complementary Metal Oxide Semiconductor
FBGA	Fine-Pitch Ball Grid Array
I/O	Input/Output
JEDEC	Joint Electron Devices Engineering Council
JTAG	Joint Test Action Group
\overline{OE}	Output Enable
SRAM	Static Random Access Memory
TAP	Test Access Port
TCK	Test Clock
TDI	Test Data-In
TDO	Test Data-Out
TMS	Test Mode Select
TQFP	Thin Quad Flat Pack
TTL	Transistor-Transistor Logic

Document Conventions

Units of Measure

Symbol	Unit of Measure
°C	degree Celsius
MHz	megahertz
μA	microamperes
mA	milliamperes
mm	millimeter
mV	millivolts
ns	nanoseconds
Ω	ohms
%	percent
pF	picofarad
V	volts

Document History Page

Document Title: CY7C0831AV/CY7C0832AV/CY7C0833V, FLEx18™ 3.3 V, 128K/256K/512K × 18 Synchronous Dual-Port RAM				
Document Number: 38-06059				
Rev.	ECN No.	Orig. of Change	Submission Date	Description of Change
**	111473	DSG	11/27/01	Change from Spec number: 38-01056 to 38-06059
*A	111942	JFU	12/21/01	Updated capacitance values Updated switching parameters and I _{SB3} Updated "Read-to-Write-to-Read (OE Controlled)" waveform Revised static discharge voltage Revised footnote regarding I _{SB3}
*B	113741	KRE	04/02/02	Updated I _{SH} values Updated ESD voltage Corrected 0853 pins L3 and L12
*C	114704	KRE	04/24/02	Added discussion of Pause/Restart for JTAG boundary scan
*D	115336	KRE	07/01/02	Revised speed offerings for all densities
*E	122307	RBI	12/27/02	Power up requirements added to Maximum Ratings Information
*F	123636	KRE	1/27/03	Revise t _{CD2} , t _{OE} , t _{OHZ} , t _{CKHZ} , t _{CKLZ} for the CY7C0853V to 4.7 ns
*G	126053	SPN	08/11/03	Separated out 4M and 9M data sheets Updated I _{SB} and I _{CC} values
*H	129443	RAZ	11/03/03	Updated I _{SB} and I _{CC} values
*I	231993	YDT	See ECN	Removed "A particular port can write to a certain location while another port is reading that location." from Functional Description.
*J	231813	WWZ	See ECN	Removed × 36 devices (CY7C0852/CY7C0851) from this datasheet. Added 0.5 M, 1 M and 9 M × 18 devices to it. Changed title to FLEx18 3.3 V 32 K/64 K/128 K/256 K/512 K × 18 Synchronous Dual-Port RAM. Changed datasheet to accommodate the removals and additions. Removed general JTAG description. Updated JTAG ID codes for all devices. Added 144-ball FBGA package for all devices. Updated selection guide table and moved to the front page. Updated block diagram to reflect × 18 configuration. Added preliminary status back due to the addition of the new devices.
*K	311054	RYQ	See ECN	Minor Change: Correct the revision indicated on the footer.
*L	329111	SPN	See ECN	Updated Marketing part numbers Updated t _{RSF}
*M	330561	RUY	See ECN	Added Byte Select Operation Table
*N	375198	YDT	See ECN	Removed Preliminary status Added I _{SB5} Changed t _{RSCNTINT} to 10ns
*O	391525	SPN	See ECN	Updated Counter reset section to reflect what is loaded into the mirror register
*P	414109	LIJ	See ECN	Corrected Ordering Codes for 0831 devices in the 133 MHz speed bin. Added CY7C0833AV-133BBI.
*Q	461113	YDT	SEE ECN	Changed VDDIO to VDD (typo) Added lead(Pb)-free parts Corrected typo in DC table
*R	2544945	VKN/AESA	07/29/08	Updated ordering information Updated Template.
*S	2668478	VKN/PYRS	02/04/09	Added CY7C0832BV part Added footnote #1 Updated Ordering information table

Document History Page *(continued)*

Document Title: CY7C0831AV/CY7C0832AV/CY7C0833V, FLEx18™ 3.3 V, 128K/256K/512K × 18 Synchronous Dual-Port RAM				
Document Number: 38-06059				
Rev.	ECN No.	Orig. of Change	Submission Date	Description of Change
*T	2897087	RAME	03/22/10	Updated Ordering Information (Removed obsolete parts). Updated Package Diagrams .
*U	3051710	ADMU	10/07/2010	Added TOC. Updated Ordering Information : Removed inactive part CY7C0831AV-133BBXI. Removed mention of previously removed parts. Added Ordering Code Definitions .
*V	3351984	ADMU	08/23/2011	Updated Features . Updated Product Selection Guide . Updated Pin Configurations . Updated Boundary Scan Hierarchy for 9-Mbit Device . Updated Switching Characteristics . Added Acronyms and Units of Measure . Updated to new template.
*W	3403638	ADMU	10/13/2011	Updated Ordering Information (Removed pruned part CY7C0832AV-133AXC). Updated Package Diagrams .
*X	4496013	ADMU	09/08/2014	Removed CY7C0832BV related information in all instances across the document. Updated Ordering Information (Updated part numbers). Updated Package Diagrams : spec 51-85141 – Changed revision from *D to *E. Updated to new template.
*Y	4581625	ADMU	11/27/2014	Updated Functional Description : Added “For a complete list of related documentation, click here .” at the end. Updated Package Diagrams : spec 51-85100 – Changed revision from *B to *C.
*Z	5437922	NILE	09/15/2016	Updated to new template. Completing Sunset Review.
AA	5840744	NILE	08/01/2017	Updated to new template. Completing Sunset Review.



Sales, Solutions, and Legal Information

Worldwide Sales and Design Support

Cypress maintains a worldwide network of offices, solution centers, manufacturer's representatives, and distributors. To find the office closest to you, visit us at [Cypress Locations](#).

Products

ARM® Cortex® Microcontrollers	cypress.com/arm
Automotive	cypress.com/automotive
Clocks & Buffers	cypress.com/clocks
Interface	cypress.com/interface
Internet of Things	cypress.com/iot
Memory	cypress.com/memory
Microcontrollers	cypress.com/mcu
PSoC	cypress.com/psoc
Power Management ICs	cypress.com/pmic
Touch Sensing	cypress.com/touch
USB Controllers	cypress.com/usb
Wireless Connectivity	cypress.com/wireless

PSoC® Solutions

[PSoC 1](#) | [PSoC 3](#) | [PSoC 4](#) | [PSoC 5LP](#)

Cypress Developer Community

[Forums](#) | [WICED IOT Forums](#) | [Projects](#) | [Video](#) | [Blogs](#) | [Training](#) | [Components](#)

Technical Support

cypress.com/support



© Cypress Semiconductor Corporation, 2001–2017. This document is the property of Cypress Semiconductor Corporation and its subsidiaries, including Spansion LLC ("Cypress"). This document, including any software or firmware included or referenced in this document ("Software"), is owned by Cypress under the intellectual property laws and treaties of the United States and other countries worldwide. Cypress reserves all rights under such laws and treaties and does not, except as specifically stated in this paragraph, grant any license under its patents, copyrights, trademarks, or other intellectual property rights. If the Software is not accompanied by a license agreement and you do not otherwise have a written agreement with Cypress governing the use of the Software, then Cypress hereby grants you a personal, non-exclusive, nontransferable license (without the right to sublicense) (1) under its copyright rights in the Software (a) for Software provided in source code form, to modify and reproduce the Software solely for use with Cypress hardware products, only internally within your organization, and (b) to distribute the Software in binary code form externally to end users (either directly or indirectly through resellers and distributors), solely for use on Cypress hardware product units, and (2) under those claims of Cypress's patents that are infringed by the Software (as provided by Cypress, unmodified) to make, use, distribute, and import the Software solely for use with Cypress hardware products. Any other use, reproduction, modification, translation, or compilation of the Software is prohibited.

TO THE EXTENT PERMITTED BY APPLICABLE LAW, CYPRESS MAKES NO WARRANTY OF ANY KIND, EXPRESS OR IMPLIED, WITH REGARD TO THIS DOCUMENT OR ANY SOFTWARE OR ACCOMPANYING HARDWARE, INCLUDING, BUT NOT LIMITED TO, THE IMPLIED WARRANTIES OF MERCHANTABILITY AND FITNESS FOR A PARTICULAR PURPOSE. To the extent permitted by applicable law, Cypress reserves the right to make changes to this document without further notice. Cypress does not assume any liability arising out of the application or use of any product or circuit described in this document. Any information provided in this document, including any sample design information or programming code, is provided only for reference purposes. It is the responsibility of the user of this document to properly design, program, and test the functionality and safety of any application made of this information and any resulting product. Cypress products are not designed, intended, or authorized for use as critical components in systems designed or intended for the operation of weapons, weapons systems, nuclear installations, life-support devices or systems, other medical devices or systems (including resuscitation equipment and surgical implants), pollution control or hazardous substances management, or other uses where the failure of the device or system could cause personal injury, death, or property damage ("Unintended Uses"). A critical component is any component of a device or system whose failure to perform can be reasonably expected to cause the failure of the device or system, or to affect its safety or effectiveness. Cypress is not liable, in whole or in part, and you shall and hereby do release Cypress from any claim, damage, or other liability arising from or related to all Unintended Uses of Cypress products. You shall indemnify and hold Cypress harmless from and against all claims, costs, damages, and other liabilities, including claims for personal injury or death, arising from or related to any Unintended Uses of Cypress products.

Cypress, the Cypress logo, Spansion, the Spansion logo, and combinations thereof, WICED, PSoC, CapSense, EZ-USB, F-RAM, and Traveo are trademarks or registered trademarks of Cypress in the United States and other countries. For a more complete list of Cypress trademarks, visit cypress.com. Other names and brands may be claimed as property of their respective owners.

Looking for pricing, stock, or lifecycle information?

Click below to explore more details on WIN SOURCE:

-  [View CY7C0833V-100BBI on WIN SOURCE](#)
-  [Cypress Semiconductor Corp Information](#)

Optimize Your Supply Chain with WIN SOURCE Solutions

-  Global Sourcing Solution
-  Obsolete Management
-  Cost Control Management
-  Shortage Management
-  Alternative Solution
-  Excess Inventory Management