





# COMPLETE FREEDOM FROM SOFT ERRORS

ASYNCHRONOUS SRAMS WITH  
ERROR-CORRECTING CODE (ECC)



# SOFT ERROR: HOW BAD IS IT?

With every new process technology node there is significant improvement in performance and power consumption along with reduction in the size of the chip. Each new process technology reduces voltage and shrinks the capacitance of the node. This reduced node capacitance make these devices more susceptible to bit failures caused by energetic particles. These bit failures are called soft errors.

Electronic devices are frequently exposed to extraterrestrial energetic particles like Alpha particles, Cosmic rays & Thermal neutrons. With today's advanced process nodes, memories are highly likely to fail due to soft errors caused by this extraterrestrial radiation.

Soft errors not only corrupt data, but can also lead to loss of function and system critical failures. Industrial controllers, military equipment, networking systems, medical devices, automotive electronics, and consumer electronics are especially vulnerable to the adverse effects of soft errors. An uncorrected soft error can lead to system failures in mission critical industrial automation, automotive engine control, and high-end security systems.





## WHAT'S THE SOLUTION?

Soft errors are usually dealt with through redundancy & software. Redundancy involves storing the same data on multiple chips to insure against data loss. It's quite expensive and takes up a lot of board space. While software doesn't take up extra board space, it is tedious, expensive and time consuming. Both these solutions are impractical in latest generation devices due to board space and product cycle time restrictions.

# COMPLETE FREEDOM FROM SOFT ERRORS

Cypress' Asynchronous SRAM with On-Chip Error Correcting Code (ECC) provides a faster, simpler and more cost effective solution than software or redundancy based ECC schemes. It is the industry's highest reliability chip, built to service a wide variety of applications.

## ERROR CORRECTING CODE (ECC)

Cypress's latest generation Asynchronous SRAM devices use (38,32) Hamming Code for single-bit error detection and correction using ECC. The hardware ECC block in Cypress' ultra-reliable Asynchronous SRAMs performs all ECC related functions in line, without user intervention.

Together, these features provide significant improvement in Soft Error Rate (SER) performance, resulting in industry leading FIT rates less than 0.1 FIT/Mbit.

## BIT-INTERLEAVING

Higher energy extraterrestrial radiation can flip multiple adjacent bits, leading to multi-bit errors. The single-bit error detection and correction capability of Error Correcting Code is supplemented by a bitinterleaving scheme to prevent the occurrence of multi-bit errors.



Embedded ECC to detect and correct all single-bit errors



Bit-interleaving to avoid multi-bit upsets



Optional ERR pin to indicate the occurrence of single-bit error



Industry leading access time: 10 ns (FAST)

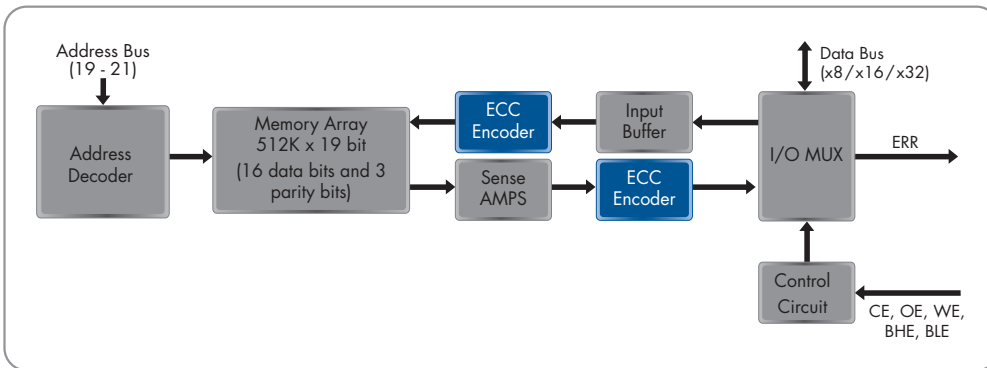
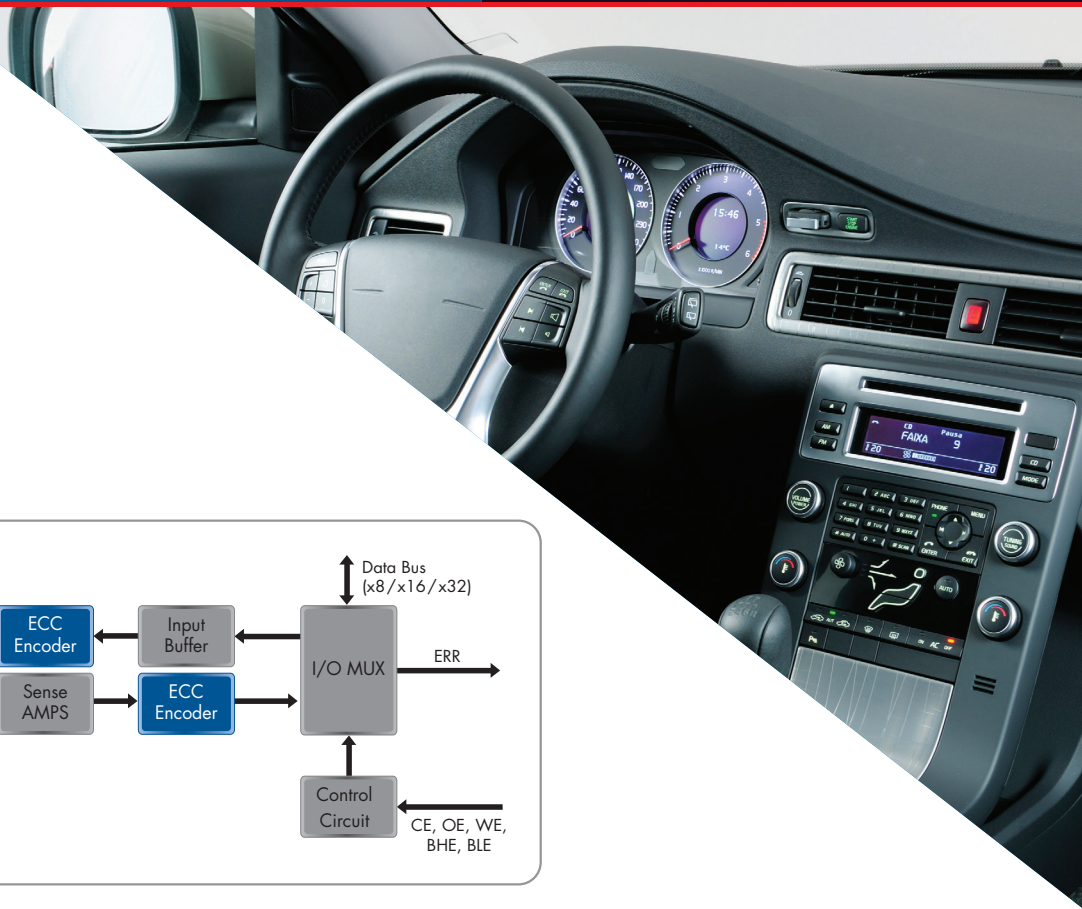

### ASYNCHRONOUS SRAM WITH ON-CHIP ECC FAMILY

PARAMETERS	4-MBIT FAST SRAM	4-MBIT LOW POWER SRAM	4-MBIT FAST SRAM WITH POWERSNOOZE™	16-MBIT FAST SRAM	16-MBIT LOW POWER SRAM	16-MBIT FAST SRAM WITH POWERSNOOZE™
ACCESS TIME	10 ns	45 ns	10 ns	10 ns	45 ns	10 ns
OPERATING CURRENT (MAX.)	45 mA	20 mA	45 mA	110 mA	36 mA	110 mA
STANDBY CURRENT (MAX.)	8 mA	8.7 µA	15 µA	30 mA	16 µA	22 µA



Ultra-low standby current: 8.7 µA (4-Mbit MoBL)



Multiple configurations (x8, x16, and x32) and operating voltages (1.8V, 3V, 5V)



Available in industrial and automotive temperature grades

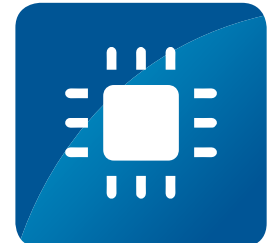

Form-fit-function compatible with current generation ASYNC SRAM devices

# HIGH PERFORMANCE AND LOW POWER. NOW A REALITY

Fast SRAM with PowerSnooze™ is a revolutionary product that eliminates the tradeoff between performance and power consumption in Asynchronous SRAM applications. In this new family of devices, the best features of Fast SRAMs (High speed) & Low-Power SRAMs (Low power consumption) are available through a novel on-chip power saving mode called PowerSnooze™.

## PERFORMANCE AND POWER TRADEOFF IN ASYNCHRONOUS SRAMS

PARAMETERS	16-MBIT FAST SRAM	16-MBIT LOW POWER SRAM	16-MBIT FAST SRAM WITH POWERSNOOZE™
ACCESS TIME	10 ns	45 ns	10 ns
ACTIVE CURRENT	110 mA	36 mA	110 mA
STANDBY CURRENT	30 mA	16 µA	22 µA

PowerSnooze is an additional power saving mode to standard Asynchronous SRAM operating modes (Active, Standby, and Data-Retention). The Deep Sleep pin (DS#) enables switching between the high performance active mode and the ultra low-power PowerSnooze mode. With deep sleep current as low as 15 µA (in 4-Mbit devices), Fast SRAM with PowerSnooze combines the best features of fast and low-power SRAM in a single device.

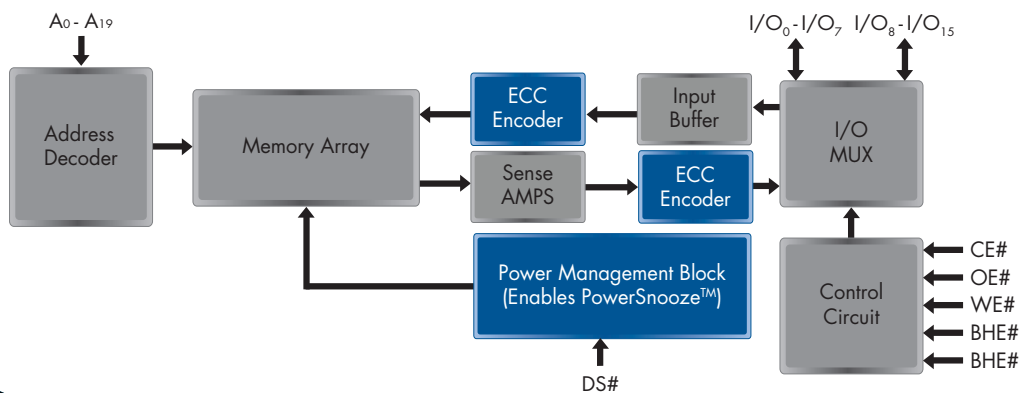

# ORDERING CODE

## FAST ASYNCHRONOUS SRAM WITH ECC

PART NUMBER	ORGANIZATION	VOLTAGE	SPEED	TEMPERATURE GRADE
CY7C1049G(E)	512 K X 8	1.8 V, 3 V, 5 V	10 ns, 15 ns	Industrial
CY7C1041G(E)	256 K x 16	1.8 V, 3 V, 5 V	10 ns, 12 ns, 15 ns, 17 ns	Industrial, Automotive
CY7C1069G(E)	2 M x 8	1.8 V, 3 V, 5 V	10 ns, 15 ns	Industrial
CY7C1061G(E)	1 M X 16	1.8 V, 3 V, 5 V	10 ns, 12 ns, 15 ns, 17 ns	Industrial, Automotive
CY7C1062G(E)	512 K X 32	1.8 V, 3 V	10 ns, 15 ns	Industrial

54-pin TSOP-II, 44-pin TSOP-II, 44-pin SOJ, 48-pin BGA, 48-pin TSOP-I, 119-pin BGA

## LOW-POWER ASYNCHRONOUS SRAM WITH ECC

PART NUMBER	ORGANIZATION	VOLTAGE	SPEED	TEMPERATURE GRADE
CY62148G	512 K X 8	1.8 V, 3 V, 5 V	45 ns, 55 ns	Industrial
CY62146G(E)	256 K x 16	1.8 V, 3 V, 5 V	45 ns, 55 ns	Industrial, Automotive
CY62147G(E)	256 K x 16	1.8 V, 3 V, 5 V	45 ns, 55 ns	Industrial, Automotive
CY62168G(E)	2 M X 8	1.8 V, 3 V, 5 V	45 ns, 55 ns	Industrial
CY62167G(E)	1 M X 16	1.8 V, 3 V, 5 V	45 ns, 55 ns	Industrial, Automotive
CY62162G(E)	512 K X 32	1.8 V, 3 V	45 ns, 55 ns	Industrial

44-pin TSOP-II, 48-pin TSOP-I, 48-pin BGA, 119-pin BGA

## FAST SRAM WITH POWERSNOOZE™

PART NUMBER	ORGANIZATION	VOLTAGE	SPEED	TEMPERATURE GRADE
CY7S1049G(E)	512 K X 8	1.8 V, 3 V, 5 V	10 ns, 15 ns	Industrial
CY7S1041G(E)	256 K X 16	1.8 V, 3 V, 5 V	10 ns, 15 ns	Industrial
CY7S1061G(E)	1 M x 16	1.8 V, 3 V, 5 V	10 ns, 15 ns	Industrial
CY7S1062G	512 K X 32	1.8 V, 3 V	10 ns, 15 ns	Industrial

48-pin BGA, 48-pin TSOP-I, 119-pin BGA

## PACKAGE DIMENSIONS

Package dimensions are shown as nominal measurements and are intended for quick reference only. Please refer to detailed product datasheets for precise package dimensions and complete specifications.

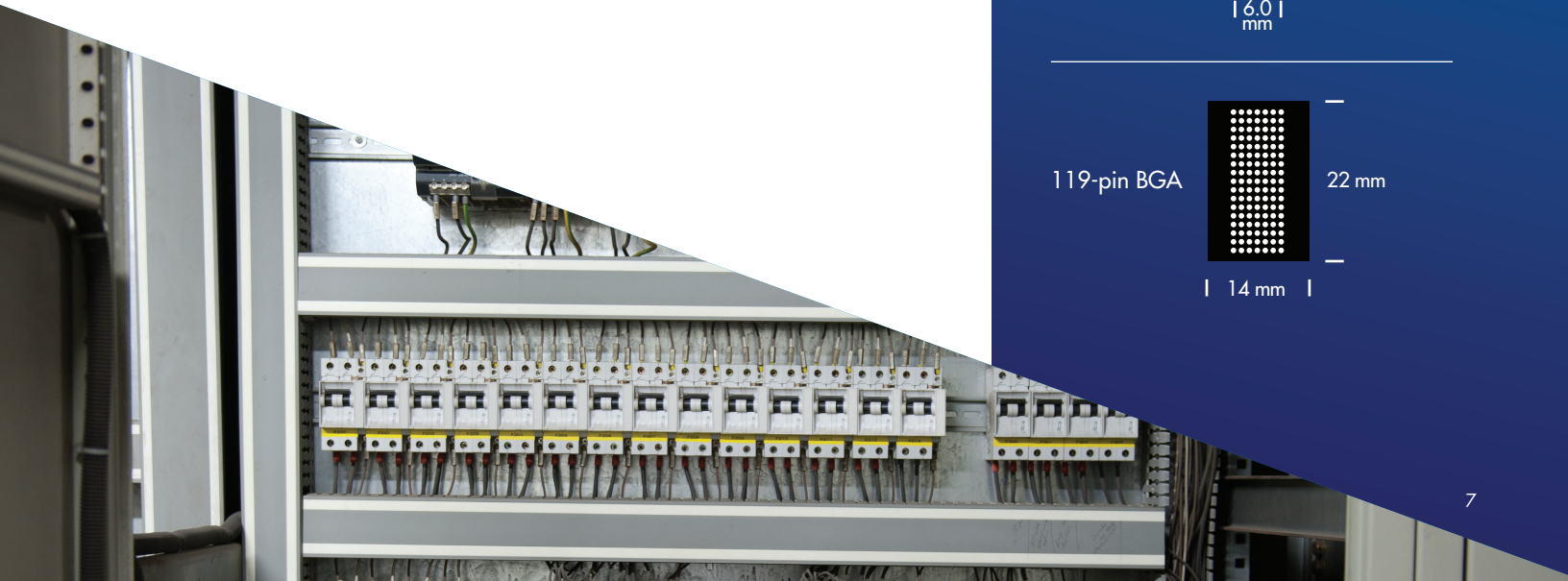
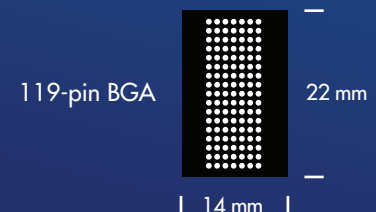
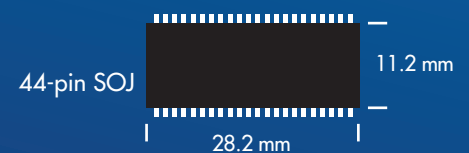
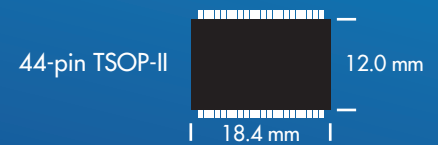
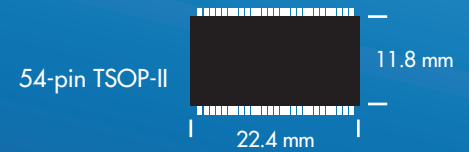

# CONTACT US

## CYPRESS HEADQUARTERS

### **Cypress Semiconductor Corporation**

198 Champion Court  
San Jose, CA 95134 USA  
Tel: +1 (408) 943-2600  
Fax: +1 (408) 943-6848  
Toll-free: +1 (800) 858-1810 (U.S. only)



[www.cypress.com](http://www.cypress.com)

## **FOR MORE INFORMATION ON ASYNC:**

[www.async.cypress.com](http://www.async.cypress.com)

## Looking for pricing, stock, or lifecycle information?

Click below to explore more details on WIN SOURCE:

-  [View CY62147G-45ZSXI on WIN SOURCE](#)
-  [Cypress Semiconductor Corp Information](#)

## Optimize Your Supply Chain with WIN SOURCE Solutions

-  Global Sourcing Solution
-  Obsolete Management
-  Cost Control Management
-  Shortage Management
-  Alternative Solution
-  Excess Inventory Management