



**THE DATASHEET OF
CY62138FV30LL-45BVXIT**



Features

- Very high-speed: 45 ns
- Temperature ranges
 - Industrial: -40 °C to 85 °C
 - Automotive-A: -40 °C to 85 °C
- Wide voltage range: 2.20 V to 3.60 V
- Pin compatible with CY62138CV25/30/33
- Ultra low standby power
 - Typical standby current: 1 μA
 - Maximum standby current: 5 μA
- Ultra low active power
 - Typical active current: 1.6 mA at f = 1 MHz
- Easy memory expansion with \overline{CE}_1 , CE_2 , and \overline{OE} Features
- Automatic power down when deselected
- Complementary metal oxide semiconductor (CMOS) for Optimum speed and power
- Offered in Pb-free 36-ball VFBGA, 32-pin TSOP II, 32-pin SOIC, 32-pin TSOP I and 32-pin STSOP packages

Functional Description

The CY62138FV30 is a high performance CMOS static RAM organized as 256K words by 8 bits. This device features advanced circuit design to provide ultra low active current. This is ideal for providing More Battery Life™ (MoBL[®]) in portable applications such as cellular telephones. The device also has an automatic power down feature that significantly reduces power consumption. Place the device into standby mode reducing power consumption when deselected (\overline{CE}_1 HIGH or CE_2 LOW).

To write to the device, take Chip Enable (\overline{CE}_1 LOW and CE_2 HIGH) and Write Enable (\overline{WE}) inputs LOW. Data on the eight I/O pins (I/O₀ through I/O₇) is then written into the location specified on the address pins (A₀ through A₁₇).

To read from the device, take Chip Enable (\overline{CE}_1 LOW and CE_2 HIGH) and Output Enable (\overline{OE}) LOW while forcing Write Enable (\overline{WE}) HIGH. Under these conditions, the contents of the memory location specified by the address pins appear on the I/O pins.

The eight input and output pins (I/O₀ through I/O₇) are placed in a high impedance state when the device is deselected (\overline{CE}_1 HIGH or CE_2 LOW), the outputs are disabled (\overline{OE} HIGH), or during a write operation (\overline{CE}_1 LOW and CE_2 HIGH and \overline{WE} LOW).

Logic Block Diagram

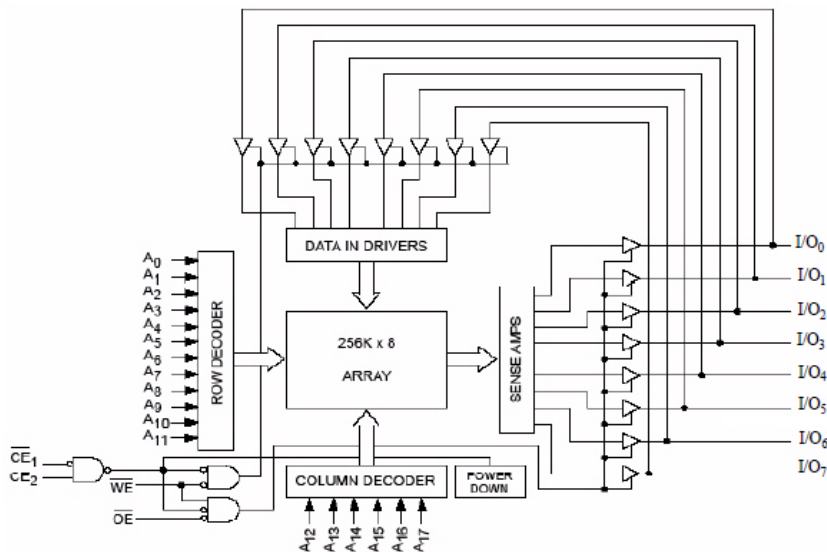

Contents

Pin Configurations	3	Ordering Information	11
Product Portfolio	3	Ordering Code Definitions	11
Maximum Ratings	4	Package Diagrams	12
Operating Range	4	Acronyms	17
Electrical Characteristics	4	Document Conventions	17
Capacitance	5	Units of Measure	17
Thermal Resistance	5	Document History Page	18
AC Test Loads and Waveforms	5	Sales, Solutions, and Legal Information	20
Data Retention Characteristics	6	Worldwide Sales and Design Support	20
Data Retention Waveform	6	Products	20
Switching Characteristics	7	PSoC [®] Solutions	20
Switching Waveforms	8	Cypress Developer Community	20
Truth Table	10	Technical Support	20

Pin Configurations

Figure 1. 36-ball VFBGA (Top View) [1]

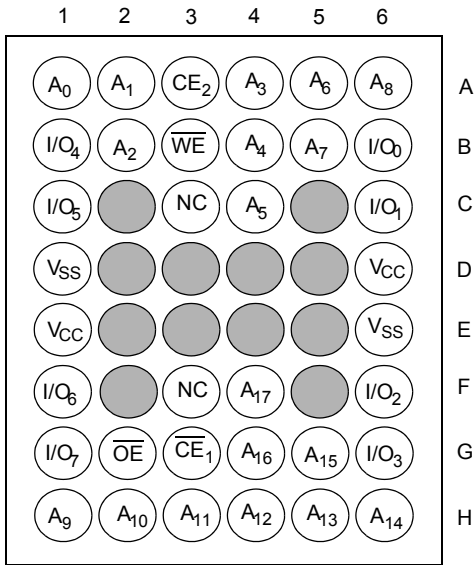

Figure 3. 32-pin TSOP I (Top View)

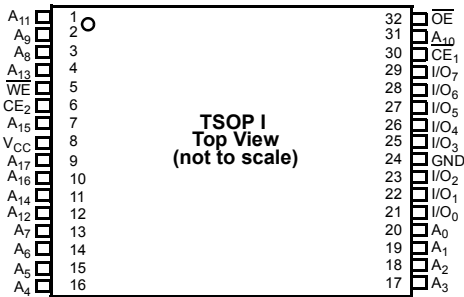

Figure 2. 32-pin SOIC/TSOP II (Top View)

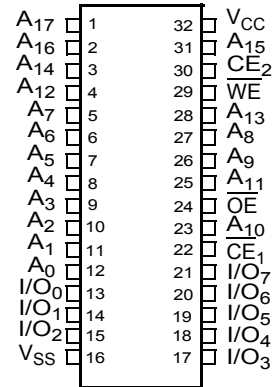
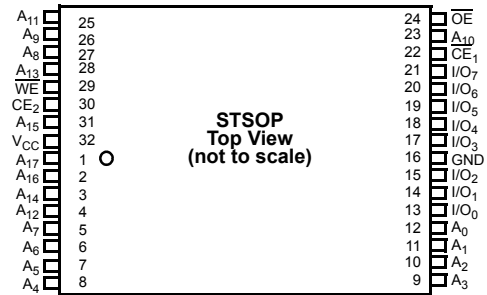

Figure 4. 32-pin STSOP (Top View)



Product Portfolio

Product	Range	V _{CC} Range (V)			Speed (ns)	Power Dissipation					
						Operating I _{CC} (mA)				Standby I _{SB2} (μA)	
		f = 1 MHz		f = f _{max}							
		Min	Typ [2]	Max		Typ [2]	Max	Typ [2]	Max		
CY62138FV30LL	Industrial / Automotive-A	2.2	3.0	3.6	45	1.6	2.5	13	18	1	5

Notes

1. NC pins are not connected on the die.
2. Typical values are included for reference only and are not guaranteed or tested. Typical values are measured at V_{CC} = V_{CC(typ)}, T_A = 25 °C.

Maximum Ratings

Exceeding maximum ratings may impair the useful life of the device. These user guidelines are not tested.

Storage temperature	-65 °C to +150 °C
Ambient temperature with power applied	-55 °C to +125 °C
Supply voltage to ground potential	-0.3 V to 3.9 V
DC voltage applied to outputs in High Z State ^[3, 4]	-0.3 V to 3.9 V

DC input voltage ^[3, 4]	-0.3 V to 3.9 V
Output current into outputs (LOW)	20 mA
Static Discharge Voltage (MIL-STD-883, Method 3015)	> 2001 V
Latch-up current	> 200 mA

Operating Range

Product	Range	Ambient Temperature	V _{CC} ^[5]
CY62138FV30LL	Industrial / Automotive-A	-40 °C to +85 °C	2.2 V to 3.6 V

Electrical Characteristics

Over the Operating Range

Parameter	Description	Test Conditions	45 ns (Industrial / Automotive-A)			Unit
			Min	Typ ^[6]	Max	
V _{OH}	Output HIGH voltage	I _{OH} = -0.1 mA	2.0	-	-	V
		I _{OH} = -1.0 mA, V _{CC} ≥ 2.70 V	2.4	-	-	V
V _{OL}	Output LOW voltage	I _{OL} = 0.1 mA	-	-	0.4	V
		I _{OL} = 2.1 mA, V _{CC} ≥ 2.70 V	-	-	0.4	V
V _{IH}	Input HIGH voltage	V _{CC} = 2.2 V to 2.7 V	1.8	-	V _{CC} + 0.3 V	V
		V _{CC} = 2.7 V to 3.6 V	2.2	-	V _{CC} + 0.3 V	V
V _{IL}	Input LOW voltage	V _{CC} = 2.2 V to 2.7 V	-0.3	-	0.6	V
		For BGA package				
		V _{CC} = 2.7 V to 3.6 V	-0.3	-	0.8	V
		V _{CC} = 2.2 V to 3.6 V	-0.3	-	0.6	V
		For other packages	-0.3	-	0.6	V
I _{IX}	Input leakage current	GND ≤ V _I ≤ V _{CC}	-1	-	+1	μA
I _{OZ}	Output leakage current	GND ≤ V _O ≤ V _{CC} , output disabled	-1	-	+1	μA
I _{CC}	V _{CC} Operating supply current	f = f _{max} = 1/t _{RC}	-	13	18	mA
		f = 1 MHz	-	1.6	2.5	
		V _{CC} = V _{CCmax} , I _{OUT} = 0 mA, CMOS levels				
I _{SB1} ^[7]	Automatic CE Power-down current—CMOS inputs	$\overline{CE}_1 \geq V_{CC} - 0.2 \text{ V}$ or $CE_2 \leq 0.2 \text{ V}$, V _{IN} ≥ V _{CC} - 0.2 V, V _{IN} ≤ 0.2 V, f = f _{max} (address and data only), f = 0 (OE, and WE), V _{CC} = 3.60 V	-	1	5	μA
I _{SB2} ^[7]	Automatic CE Power-down current—CMOS inputs	$\overline{CE}_1 \geq V_{CC} - 0.2 \text{ V}$ or $CE_2 \leq 0.2 \text{ V}$, V _{IN} ≥ V _{CC} - 0.2 V or V _{IN} ≤ 0.2 V, f = 0, V _{CC} = 3.60 V	-	1	5	μA

Notes

- V_{IL(min)} = -2.0 V for pulse durations less than 20 ns.
- V_{IH(max)} = V_{CC} + 0.75 V for pulse durations less than 20 ns.
- Full device AC operation assumes a 100 μs ramp time from 0 to V_{CC(min)} and 200 μs wait time after V_{CC} stabilization.
- Typical values are included for reference only and are not guaranteed or tested. Typical values are measured at V_{CC} = V_{CC(typ.)}, T_A = 25 °C.
- Chip enables (CE₁ and CE₂) must be at CMOS level to meet the I_{SB1} / I_{SB2} / I_{CCDR} spec. Other inputs can be left floating.

Capacitance

Parameter ^[8]	Description	Test Conditions	Max	Unit
C _{IN}	Input Capacitance	T _A = 25 °C, f = 1 MHz, V _{CC} = V _{CC(typ.)}	10	pF
C _{OUT}	Output Capacitance		10	pF

Thermal Resistance

Parameter ^[8]	Description	Test Conditions	32-pin SOIC	36-ball VFBGA	32-pin TSOP II	32-pin STSOP	32-pin TSOP I	Unit
Θ _{JA}	Thermal resistance (Junction to Ambient)	Still air, soldered on a 3 × 4.5 inch, two layer printed circuit board	44.53	38.49	44.16	59.72	50.19	°C/W
Θ _{JC}	Thermal resistance (Junction to Case)		24.05	17.66	11.97	15.38	14.59	°C/W

AC Test Loads and Waveforms

Figure 5. AC Test Loads and Waveforms

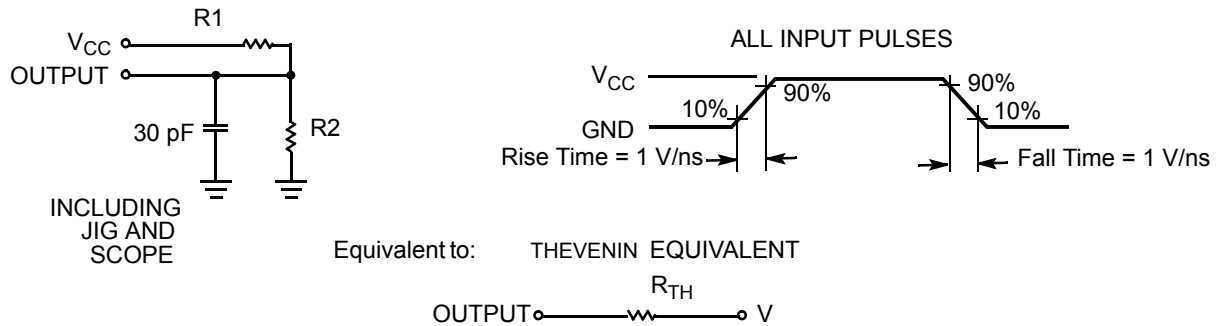

Parameter	2.5 V (2.2 V to 2.7 V)	3.0 V (2.7 V to 3.6 V)	Unit
R1	16667	1103	Ω
R2	15385	1554	Ω
R _{TH}	8000	645	Ω
V _{TH}	1.20	1.75	V

Note

8. Tested initially and after any design or process changes that may affect these parameters.

Data Retention Characteristics

Over the Operating Range

Parameter	Description	Conditions	Min	Typ ^[9]	Max	Unit
V_{DR}	V_{CC} for data retention		1.5	–	–	V
I_{CCDR} ^[10]	Data retention current	$V_{CC} = 1.5\text{ V}$, $\overline{CE}_1 \geq V_{CC} - 0.2\text{ V}$ or $CE_2 \leq 0.2\text{ V}$, $V_{IN} \geq V_{CC} - 0.2\text{ V}$ or $V_{IN} \leq 0.2\text{ V}$	–	1	4	μA
t_{CDR} ^[11]	Chip deselect to data retention time		0	–	–	ns
t_R ^[12]	Operation recovery time		45	–	–	ns

Data Retention Waveform

Figure 6. Data Retention Waveform^[13]

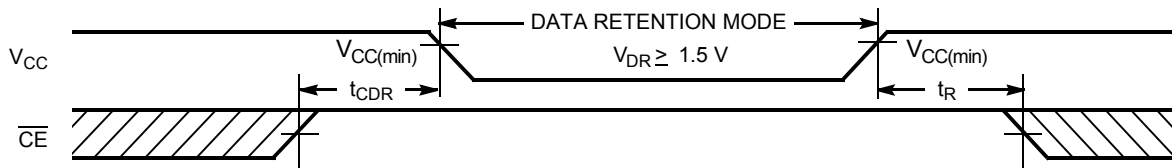

Notes

9. Typical values are included for reference only and are not guaranteed or tested. Typical values are measured at $V_{CC} = V_{CC(typ)}$, $T_A = 25\text{ }^\circ\text{C}$.
10. Chip enables (\overline{CE}_1 and CE_2) must be at CMOS level to meet the I_{SB1} / I_{SB2} / I_{CCDR} spec. Other inputs can be left floating.
11. Tested initially and after any design or process changes that may affect these parameters.
12. Full device AC operation requires linear V_{CC} ramp from V_{DR} to $V_{CC(min)} \geq 100\text{ }\mu\text{s}$ or stable at $V_{CC(min)} \geq 100\text{ }\mu\text{s}$.
13. \overline{CE} is the logical combination of \overline{CE}_1 and CE_2 . When \overline{CE}_1 is LOW and CE_2 is HIGH, \overline{CE} is LOW; when \overline{CE}_1 is HIGH or CE_2 is LOW, \overline{CE} is HIGH.

Switching Characteristics

Over the Operating Range

Parameter [14, 15]	Description	45 ns (Industrial/ Automotive-A)		Unit
		Min	Max	
Read Cycle				
t_{RC}	Read cycle time	45	–	ns
t_{AA}	Address to data valid	–	45	ns
t_{OHA}	Data hold from address change	10	–	ns
t_{ACE}	\overline{CE}_1 LOW and CE_2 HIGH to data valid	–	45	ns
t_{DOE}	\overline{OE} LOW to data valid	–	22	ns
t_{LZOE}	\overline{OE} LOW to Low Z [16]	5	–	ns
t_{HZOE}	\overline{OE} HIGH to High Z [16, 17]	–	18	ns
t_{LZCE}	\overline{CE}_1 LOW and CE_2 HIGH to Low Z [16]	10	–	ns
t_{HZCE}	\overline{CE}_1 HIGH or CE_2 LOW to High Z [16, 17]	–	18	ns
t_{PU}	\overline{CE}_1 LOW and CE_2 HIGH to Power-up	0	–	ns
t_{PD}	\overline{CE}_1 HIGH or CE_2 LOW to Power-down	–	45	ns
Write Cycle [18, 19]				
t_{WC}	Write cycle time	45	–	ns
t_{SCE}	\overline{CE}_1 LOW and CE_2 HIGH to write end	35	–	ns
t_{AW}	Address setup to write end	35	–	ns
t_{HA}	Address hold from write end	0	–	ns
t_{SA}	Address setup to Write Start	0	–	ns
t_{PWE}	\overline{WE} pulse Width	35	–	ns
t_{SD}	Data setup to write end	25	–	ns
t_{HD}	Data hold from write end	0	–	ns
t_{HZWE}	\overline{WE} LOW to High Z [16, 17]	–	18	ns
t_{LZWE}	\overline{WE} HIGH to Low Z [16]	10	–	ns

Notes

14. In an earlier revision of this device, under a specific application condition, READ and WRITE operations were limited to switching of the chip enable signal as described in the Application Note AN66311. However, the issue has been fixed and in production now, and hence, this Application Notes is no longer applicable. It is available for download on our website as it contains information on the date code of the parts, beyond which the fix has been in production.
15. Test conditions for all parameters other than tristate parameters assume signal transition time of 3 ns or less (1 V/ns), timing reference levels of $V_{CC(typ)}/2$, input pulse levels of 0 to $V_{CC(typ)}$, and output loading of the specified I_{OL}/I_{OH} as shown in the [AC Test Loads and Waveforms on page 5](#).
16. At any given temperature and voltage condition, t_{HZCE} is less than t_{LZCE} , t_{HZOE} is less than t_{LZOE} , and t_{HZWE} is less than t_{LZWE} for any given device.
17. t_{HZOE} , t_{HZCE} , and t_{HZWE} transitions are measured when the output enters a high impedance state.
18. The internal write time of the memory is defined by the overlap of \overline{WE} , $CE_1 = V_{IL}$, and $CE_2 = V_{IH}$. All signals must be ACTIVE to initiate a write and any of these signals can terminate a write by going INACTIVE. Reference the data input setup and hold timing to the edge of the signal that terminates the write.
19. The minimum write pulse width for Write Cycle No. 3 (\overline{WE} controlled, \overline{OE} LOW) should be the sum of t_{HZWE} and t_{SD} .

Switching Waveforms

Figure 7. Read Cycle 1 (Address Transition Controlled) [20, 21]

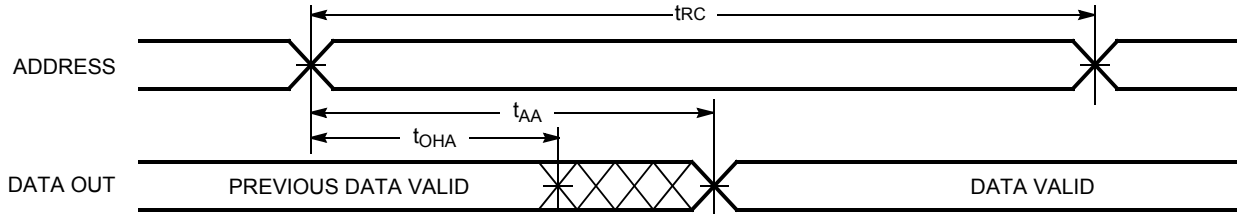

Figure 8. Read Cycle No. 2 ($\overline{\text{OE}}$ Controlled) [21, 22, 23]

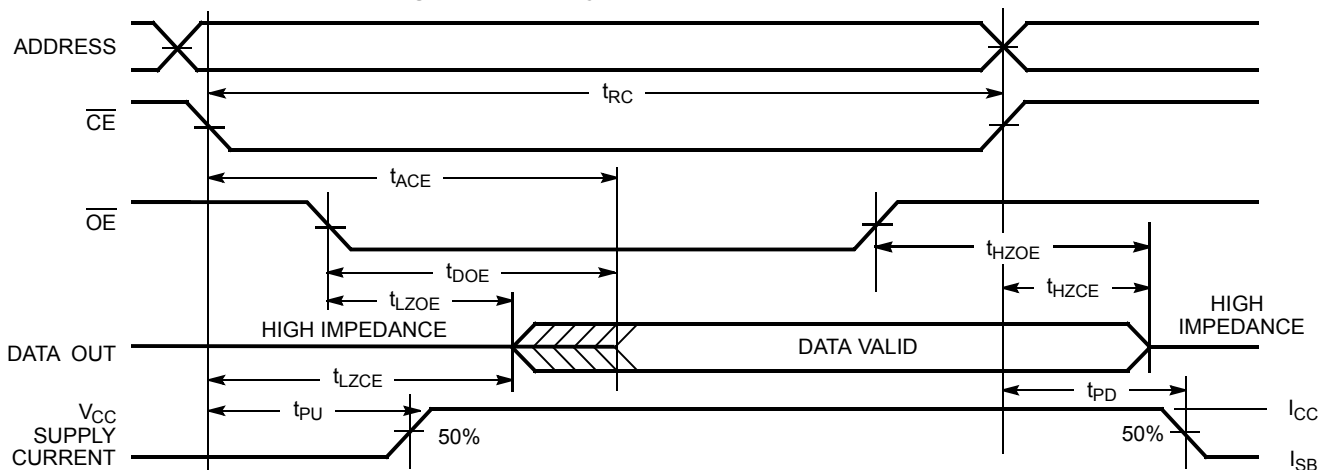
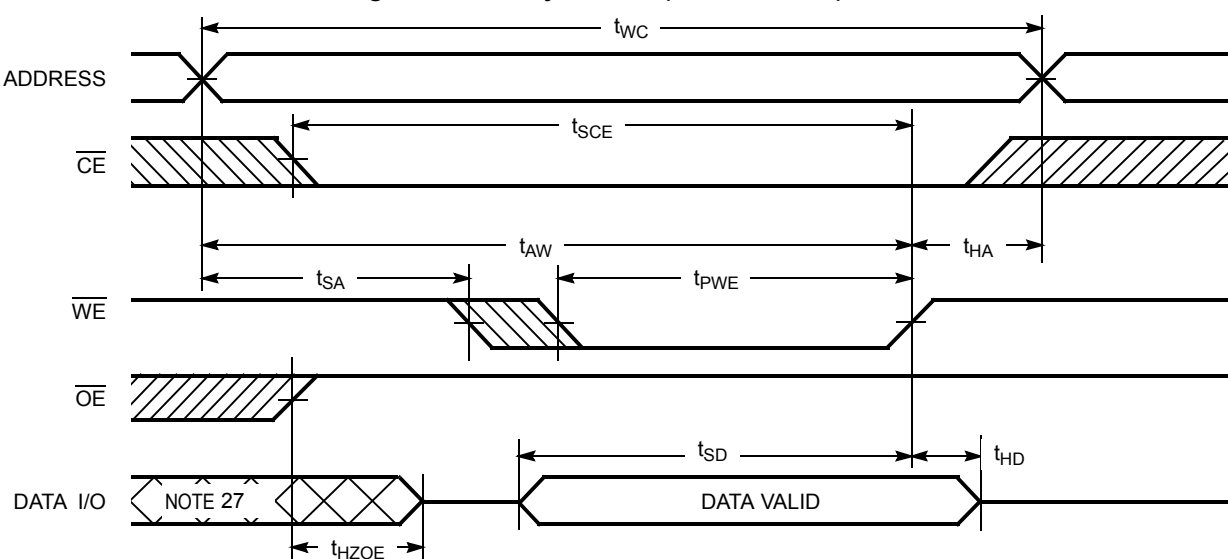

Figure 9. Write Cycle No. 1 ($\overline{\text{WE}}$ Controlled) [23, 24, 25, 26]



Notes

20. The device is continuously selected. $\overline{\text{OE}}$, $\overline{\text{CE}}_1 = V_{\text{IL}}$, $\text{CE}_2 = V_{\text{IH}}$.
21. WE is HIGH for read cycle.
22. Address valid before or similar to $\overline{\text{CE}}_1$ transition LOW and CE_2 transition HIGH.
23. CE is the logical combination of $\overline{\text{CE}}_1$ and CE_2 . When $\overline{\text{CE}}_1$ is LOW and CE_2 is HIGH, $\overline{\text{CE}}$ is LOW; when $\overline{\text{CE}}_1$ is HIGH or CE_2 is LOW, $\overline{\text{CE}}$ is HIGH.
24. The internal write time of the memory is defined by the overlap of WE, $\overline{\text{CE}}_1 = V_{\text{IL}}$, and $\text{CE}_2 = V_{\text{IH}}$. All signals must be ACTIVE to initiate a write and any of these signals can terminate a write by going INACTIVE. Reference the data input setup and hold timing to the edge of the signal that terminates the write.
25. Data I/O is high impedance if $\overline{\text{OE}} = V_{\text{IH}}$.
26. If $\overline{\text{CE}}_1$ goes HIGH or CE_2 goes LOW simultaneously with $\overline{\text{WE}}$ HIGH, the output remains in high impedance state.
27. During this period, the I/Os are in output state. Do not apply input signals.

Switching Waveforms (continued)

Figure 10. Write Cycle No. 2 (\overline{CE}_1 or CE_2 Controlled) [28, 29, 30, 31]

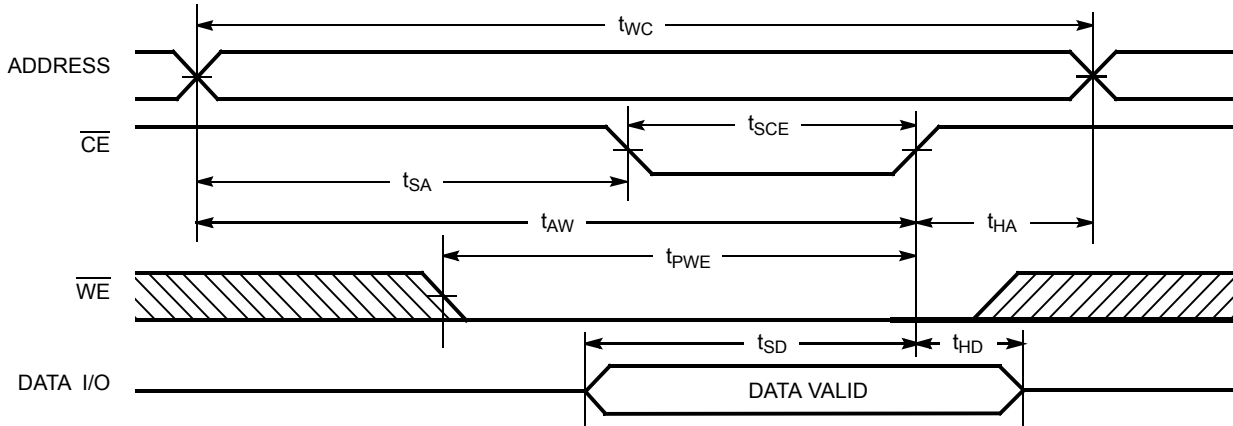
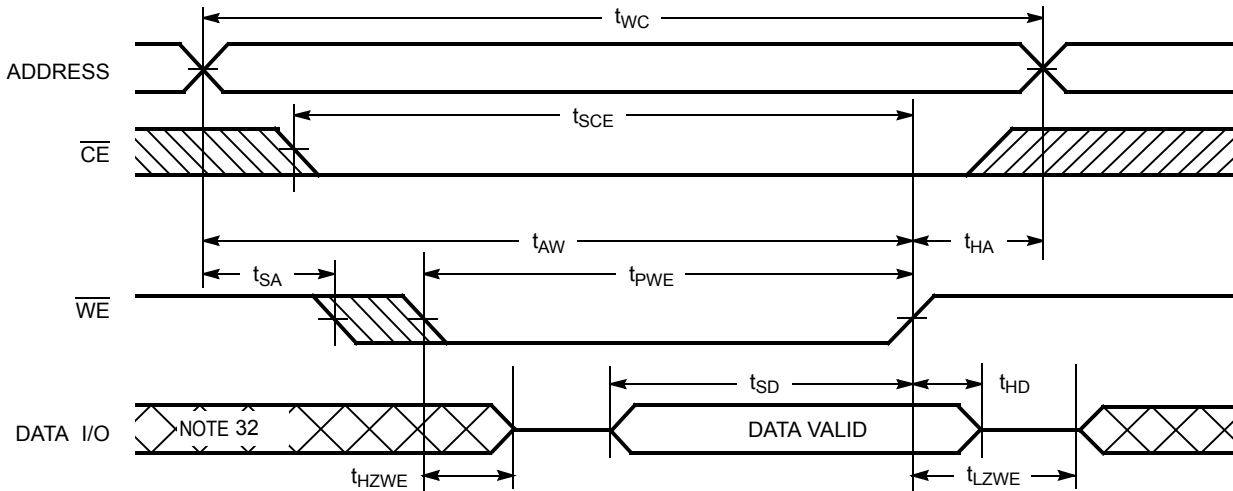

Figure 11. Write Cycle No. 3 (\overline{WE} Controlled, \overline{OE} LOW) [28, 31, 33]



Notes

- 28. \overline{CE} is the logical combination of \overline{CE}_1 and CE_2 . When \overline{CE}_1 is LOW and CE_2 is HIGH, \overline{CE} is LOW; when \overline{CE}_1 is HIGH or CE_2 is LOW, \overline{CE} is HIGH.
- 29. The internal write time of the memory is defined by the overlap of \overline{WE} , $\overline{CE}_1 = V_{IL}$, and $CE_2 = V_{IH}$. All signals must be ACTIVE to initiate a write and any of these signals can terminate a write by going INACTIVE. Reference the data input setup and hold timing to the edge of the signal that terminates the write.
- 30. Data I/O is high impedance if $\overline{OE} = V_{IH}$.
- 31. If \overline{CE}_1 goes HIGH or CE_2 goes LOW simultaneously with \overline{WE} HIGH, the output remains in high impedance state.
- 32. During this period, the I/Os are in output state. Do not apply input signals.
- 33. The minimum write pulse width for Write Cycle No. 2 (\overline{WE} controlled, \overline{OE} LOW) should be the sum of t_{HZWE} and t_{SD} .

Truth Table

\overline{CE}_1	CE_2	\overline{WE}	\overline{OE}	Inputs/Outputs	Mode	Power
H	X ^[34]	X	X	High Z	Deselect/Power-down	Standby (I_{SB})
X ^[34]	L	X	X	High Z	Deselect/Power-down	Standby (I_{SB})
L	H	H	L	Data out	Read	Active (I_{CC})
L	H	H	H	High Z	Output disabled	Active (I_{CC})
L	H	L	X	Data in	Write	Active (I_{CC})

Note

34. The 'X' (Don't care) state for the Chip enables (\overline{CE}_1 and CE_2) in the truth table refer to the logic state (either HIGH or LOW). Intermediate voltage levels on these pins is not permitted.

Ordering Information

Speed (ns)	Ordering Code	Package Diagram	Package Type	Operating Range
45	CY62138FV30LL-45BVXI	51-85149	36-ball VFBGA (Pb-free)	Industrial
	CY62138FV30LL-45ZAXI	51-85094	32-pin STSOP (Pb-free)	
	CY62138FV30LL-45ZXI	51-85056	32-pin TSOP I (Pb-free)	
	CY62138FV30LL-45SXI	51-85081	32-pin SOIC (Pb-free)	
	CY62138FV30LL-45ZAXA	51-85094	32-pin STSOP (Pb-free)	Automotive-A

Ordering Code Definitions

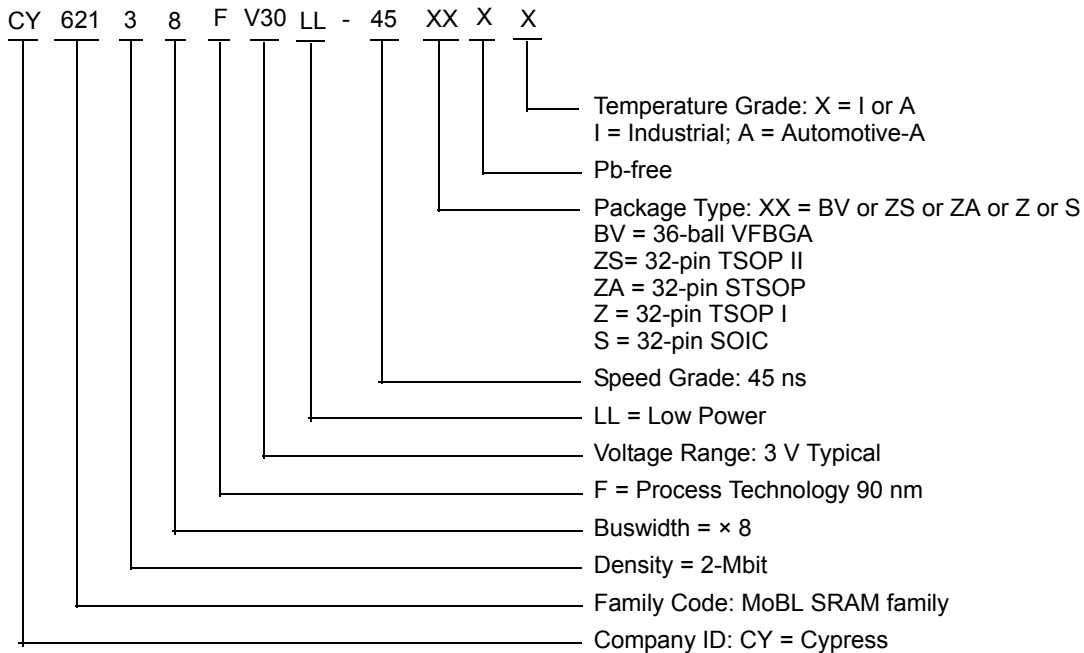

Package Diagrams

Figure 12. 36-ball VFBGA (6 × 8 × 1.0 mm) BV36A Package Outline, 51-85149

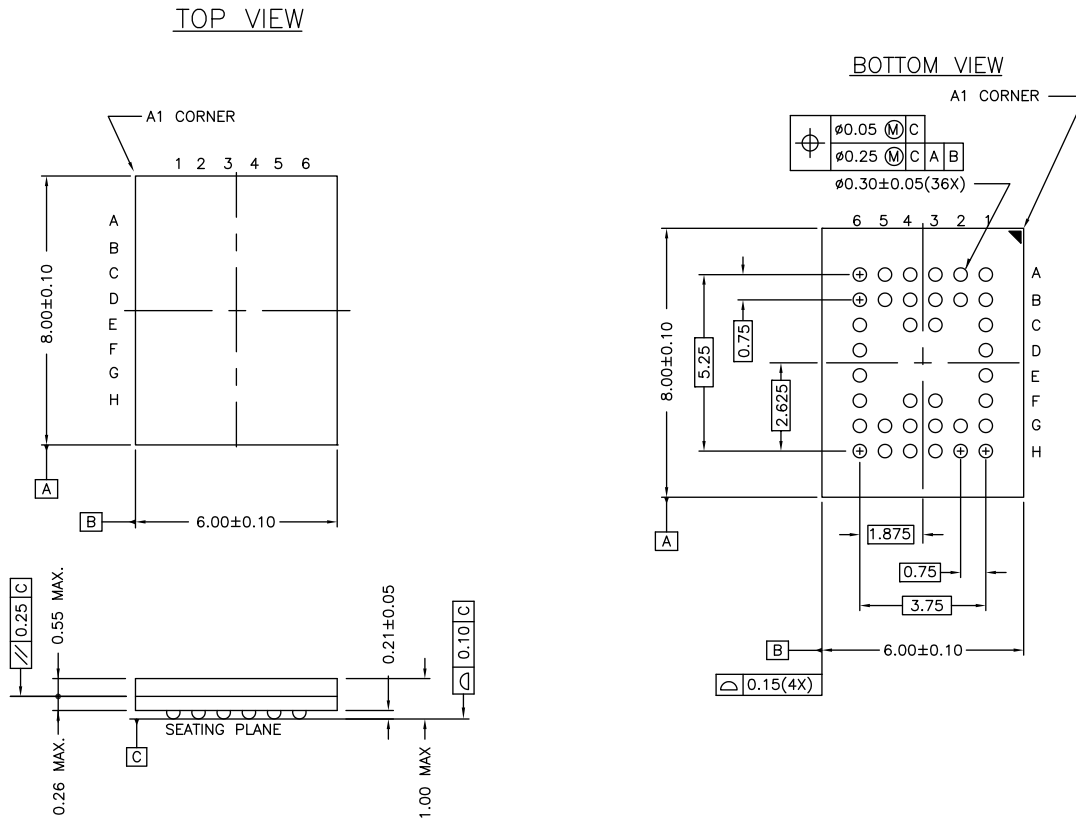

51-85149 *E

Package Diagrams (continued)

Figure 13. 32-pin TSOP II (20.95 × 11.76 × 1.0 mm) ZS32 Package Outline, 51-85095

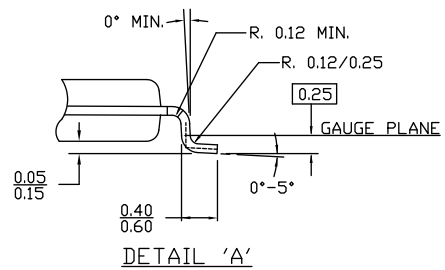
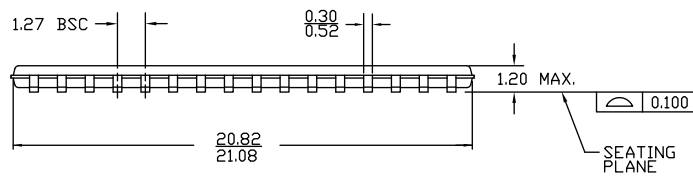
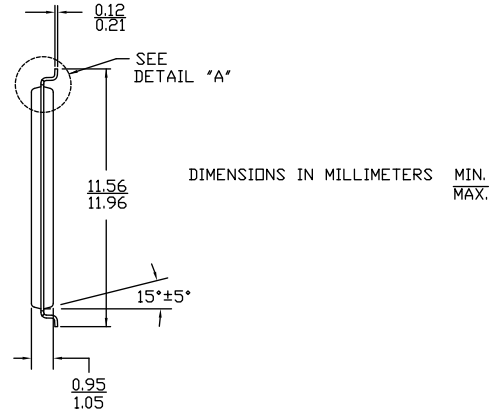
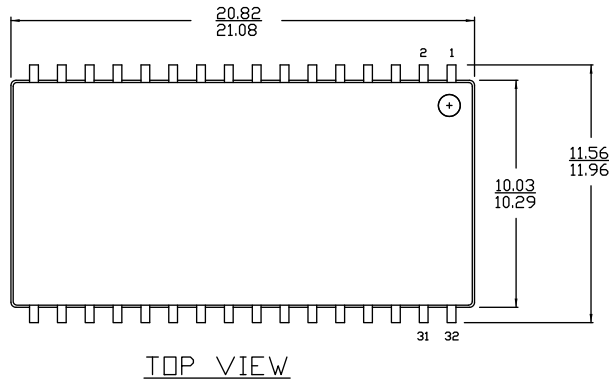

51-85095 *B

Package Diagrams (continued)

Figure 14. 32-pin Molded SOIC (450 Mil) S32.45/SZ32.45 Package Outline, 51-85081

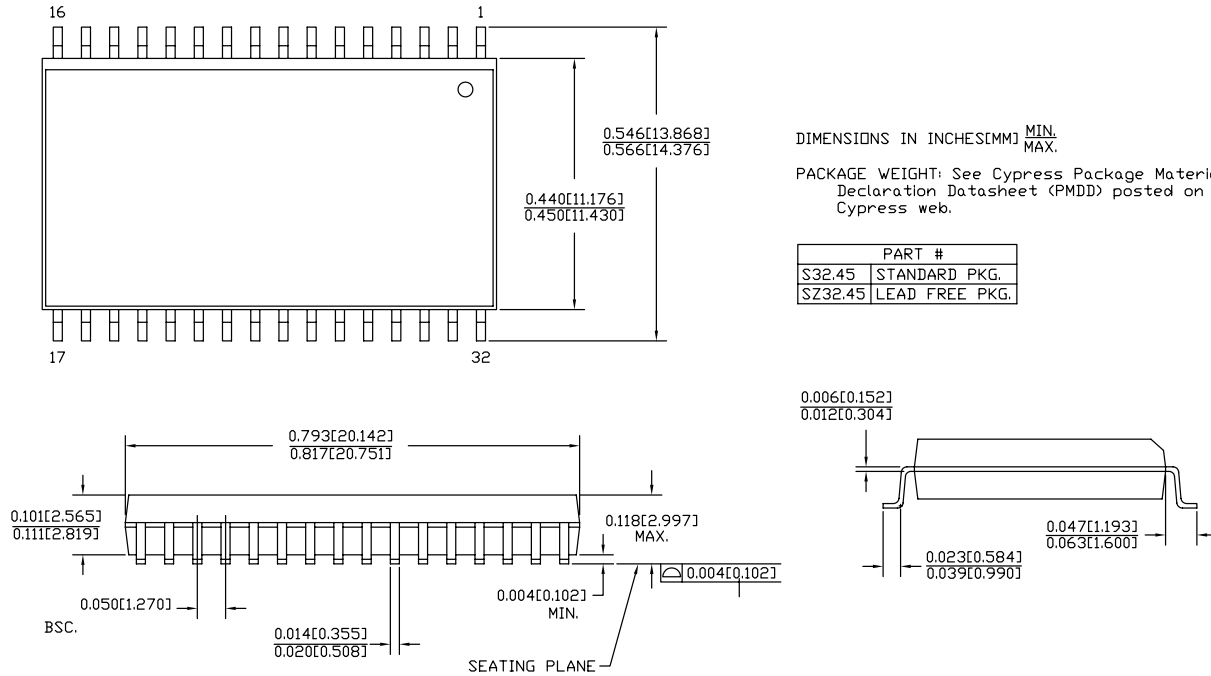

51-85081 *E

Package Diagrams (continued)

Figure 15. 32-pin TSOP I (8 × 20 × 1.0 mm) Z32R Package Outline, 51-85056

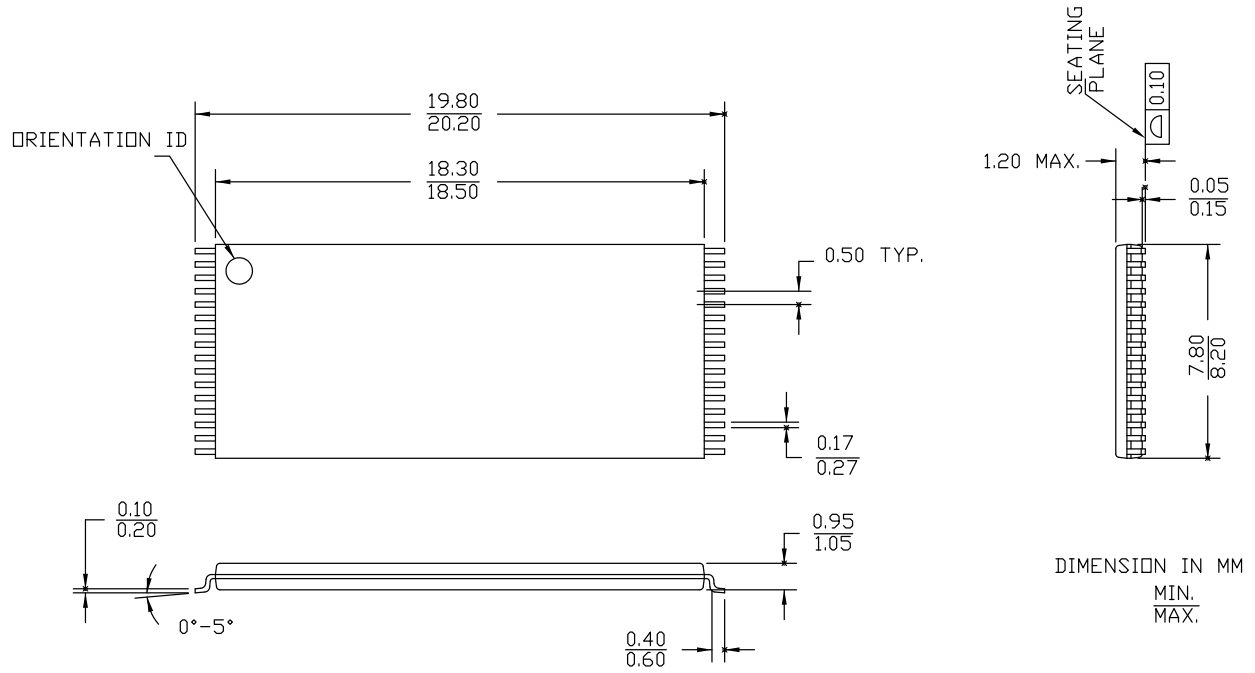

51-85056 *G

Package Diagrams (continued)

Figure 16. 32-pin STSOP (8 × 13.4 × 1.2 mm) ZA32 Package Outline, 51-85094

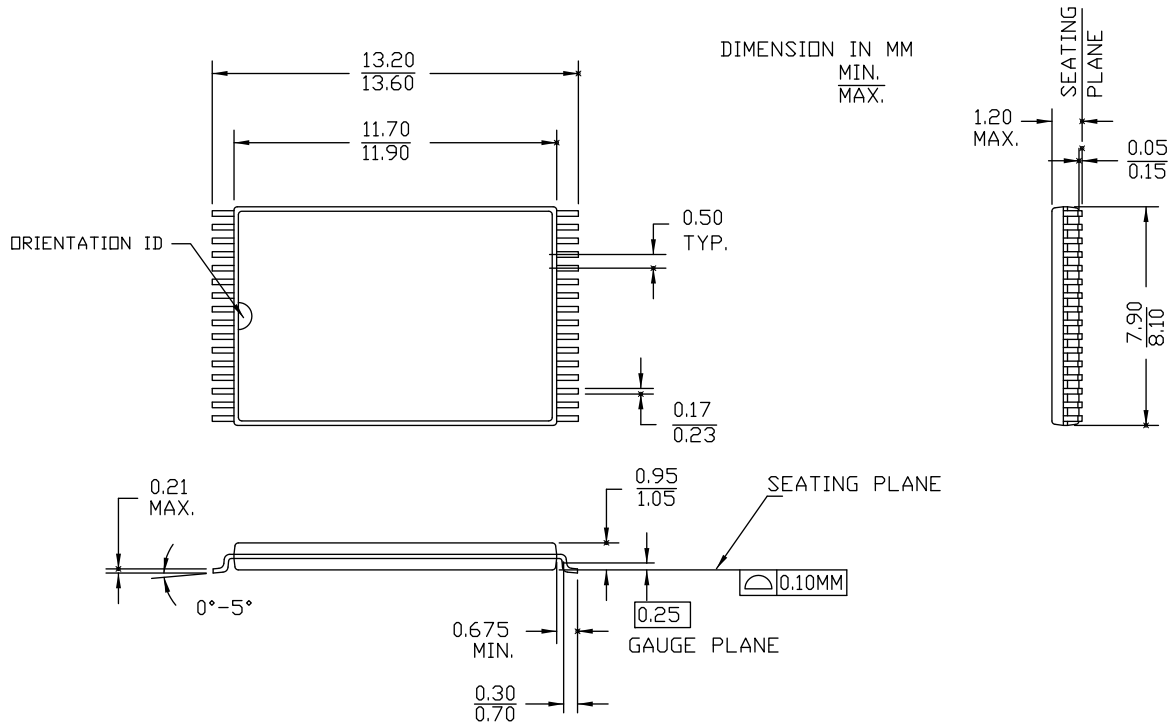

51-85094 *G

Acronyms

Acronym	Description
BGA	Ball Grid Array
CMOS	Complementary Metal Oxide Semiconductor
I/O	Input/Output
OE	Output Enable
SOIC	Small-Outline Integrated Circuit
SRAM	Static Random Access Memory
STSOP	Small Thin Small Outline Package
TSOP	Thin Small Outline Package
VFBGA	Very Fine-Pitch Ball Grid Array
WE	Write Enable

Document Conventions

Units of Measure

Symbol	Unit of Measure
°C	degree Celsius
MHz	megahertz
μA	microampere
μs	microsecond
mA	milliampere
mm	millimeter
ns	nanosecond
Ω	ohm
%	percent
pF	picofarad
V	volt
W	watt

Document History Page

Document Title: CY62138FV30 MoBL [®] , 2-Mbit (256 K × 8) Static RAM Document Number: 001-08029				
Rev.	ECN No.	Submission Date	Orig. of Change	Description of Change
**	463660	See ECN	NXR	New data sheet.
*A	467351	See ECN	NXR	Added 32-pin TSOP II package, 32 pin TSOP I and 32 pin STSOP packages Changed ball A3 from NC to CE ₂ in 36-ball FBGA pin out
*B	566724	See ECN	NXR	Converted from Preliminary to Final Corrected typo in 32 pin TSOP II pin configuration diagram on page #2 (changed pin 24 from CE ₁ to OE and pin 22 from CE to CE ₁) Changed the I _{CC(max)} value from 2.25 mA to 2.5 mA for test condition f=1 MHz Changed the I _{SB2(typ)} value from 0.5 μA to 1 μA Changed the I _{SB2(max)} value from 2.5 μA to 5 μA Changed the I _{CCDR(typ)} value from 0.5 μA to 1 μA and I _{CCDR(max)} value from 2.5 μA to 4 μA
*C	797956	See ECN	VKN	Added 32-pin SOIC package Updated VIL spec for SOIC, TSOP-II, TSOP-I, and STSOP packages on Electrical characteristics table
*D	809101	See ECN	VKN	Corrected typo in the Ordering Information table
*E	940341	See ECN	VKN	Added footnote #7 related to I _{SB2} and I _{CCDR}
*F	2769239	09/25/09	VKN / AESA	Included Automotive-A information
*G	3055119	10/12/2010	RAME	Updated and converted all tablenotes into Footnote Added Ordering Code Definitions . Updated All Package Diagrams . Added Acronyms and Units of Measure table Updated data sheet as per new template.
*H	3061313	10/15/2010	RAME	Minor changes: Corrected "IO" to "I/O"
*I	3078557	11/04/2010	RAME	Corrected 55 C to -55C in Ambient Temperature with Power applied in Maximum Ratings Section
*J	3235744	04/20/2011	RAME	Removed the note "For best practice recommendations, refer to the Cypress application Note "System Design Guidelines" at http://www.cypress.com " in page 1 and its reference in Functional Description . Updated Package Diagrams .
*K	3285093	06/16/2011	RAME	Updated in new template.
*L	3845087	12/18/2012	TAVA	Updated Ordering Information (Updated part numbers). Updated Package Diagrams : spec 51-85149 – Changed revision from *D to *E. spec 51-85081 – Changed revision from *C to *E.
*M	4099045	08/19/2013	VINI	Updated Switching Characteristics : Added Note 14 and referred the same note in "Parameter" column. Updated in new template.

Document History Page (continued)

Document Title: CY62138FV30 MoBL [®] , 2-Mbit (256 K × 8) Static RAM Document Number: 001-08029				
Rev.	ECN No.	Submission Date	Orig. of Change	Description of Change
*N	4377056	05/12/2014	MEMJ	<p>Updated Switching Characteristics: Added Note 19 and referred the same note in "Write Cycle".</p> <p>Updated Switching Waveforms: Added Note 33 and referred the same note in Figure 11.</p> <p>Updated Package Diagrams: spec 51-85056 – Changed revision from *F to *G. spec 51-85094 – Changed revision from *F to *G.</p> <p>Completing Sunset Review.</p>

Sales, Solutions, and Legal Information

Worldwide Sales and Design Support

Cypress maintains a worldwide network of offices, solution centers, manufacturer's representatives, and distributors. To find the office closest to you, visit us at [Cypress Locations](#).

Products

Automotive	cypress.com/go/automotive
Clocks & Buffers	cypress.com/go/clocks
Interface	cypress.com/go/interface
Lighting & Power Control	cypress.com/go/powerpsoc cypress.com/go/plc
Memory	cypress.com/go/memory
PSoC	cypress.com/go/psoc
Touch Sensing	cypress.com/go/touch
USB Controllers	cypress.com/go/USB
Wireless/RF	cypress.com/go/wireless

PSoC[®] Solutions

[psoc.cypress.com/solutions](#)
[PSoC 1](#) | [PSoC 3](#) | [PSoC 4](#) | [PSoC 5LP](#)

Cypress Developer Community

[Community](#) | [Forums](#) | [Blogs](#) | [Video](#) | [Training](#)

Technical Support

[cypress.com/go/support](#)

© Cypress Semiconductor Corporation, 2006-2014. The information contained herein is subject to change without notice. Cypress Semiconductor Corporation assumes no responsibility for the use of any circuitry other than circuitry embodied in a Cypress product. Nor does it convey or imply any license under patent or other rights. Cypress products are not warranted nor intended to be used for medical, life support, life saving, critical control or safety applications, unless pursuant to an express written agreement with Cypress. Furthermore, Cypress does not authorize its products for use as critical components in life-support systems where a malfunction or failure may reasonably be expected to result in significant injury to the user. The inclusion of Cypress products in life-support systems application implies that the manufacturer assumes all risk of such use and in doing so indemnifies Cypress against all charges.



Any Source Code (software and/or firmware) is owned by Cypress Semiconductor Corporation (Cypress) and is protected by and subject to worldwide patent protection (United States and foreign), United States copyright laws and international treaty provisions. Cypress hereby grants to licensee a personal, non-exclusive, non-transferable license to copy, use, modify, create derivative works of, and compile the Cypress Source Code and derivative works for the sole purpose of creating custom software and or firmware in support of licensee product to be used only in conjunction with a Cypress integrated circuit as specified in the applicable agreement. Any reproduction, modification, translation, compilation, or representation of this Source Code except as specified above is prohibited without the express written permission of Cypress.

Disclaimer: CYPRESS MAKES NO WARRANTY OF ANY KIND, EXPRESS OR IMPLIED, WITH REGARD TO THIS MATERIAL, INCLUDING, BUT NOT LIMITED TO, THE IMPLIED WARRANTIES OF MERCHANTABILITY AND FITNESS FOR A PARTICULAR PURPOSE. Cypress reserves the right to make changes without further notice to the materials described herein. Cypress does not assume any liability arising out of the application or use of any product or circuit described herein. Cypress does not authorize its products for use as critical components in life-support systems where a malfunction or failure may reasonably be expected to result in significant injury to the user. The inclusion of Cypress' product in a life-support systems application implies that the manufacturer assumes all risk of such use and in doing so indemnifies Cypress against all charges.

Use may be limited by and subject to the applicable Cypress software license agreement.

Looking for pricing, stock, or lifecycle information?

Click below to explore more details on WIN SOURCE:

-  [View CY62138FV30LL-45BVXIT on WIN SOURCE](#)
-  [Cypress Semiconductor Corp Information](#)

Optimize Your Supply Chain with WIN SOURCE Solutions

-  Global Sourcing Solution
-  Obsolete Management
-  Cost Control Management
-  Shortage Management
-  Alternative Solution
-  Excess Inventory Management