



**THE DATASHEET OF
CY62137FV30LL-55ZSXET**



Features

- Very high speed: 45 ns
- Temperature ranges
 - Automotive-A: -40 °C to +85 °C
 - Automotive-E: -40 °C to +125 °C
- Wide voltage range: 2.20 V–3.60 V
- Pin compatible with CY62137CV/CV25/CV30/CV33, CY62137V, and CY62137EV30
- Ultra low standby power
 - Typical standby current: 1 μA (Automotive-A)
 - Maximum standby current: 5 μA (Automotive-A)
- Ultra low active power
 - Typical active current: 1.6 mA at f = 1 MHz (45 ns speed)
- Easy memory expansion with \overline{CE} and \overline{OE} features
- Automatic power down when deselected
- Complementary metal oxide semiconductor (CMOS) for optimum speed and power
- Byte power down feature
- Available in 44-pin thin small outline package (TSOP) II package

Functional Description

The CY62137FV30 is a high performance CMOS static RAM organized as 128K words by 16 bits. This device features advanced circuit design to provide ultra low active current. This is ideal for providing More Battery Life™ (MoBL®) in portable applications such as cellular telephones. The device also has an automatic power down feature that significantly reduces power consumption when addresses are not toggling. Placing the device into standby mode reduces power consumption by more than 99% when deselected (\overline{CE} HIGH or both \overline{BLE} and \overline{BHE} are HIGH). The input and output pins (I/O₀ through I/O₁₅) are placed in a high impedance state in the following conditions when the device is deselected (\overline{CE} HIGH), the outputs are disabled (\overline{OE} HIGH), both the Byte High Enable and the Byte Low Enable are disabled (\overline{BHE} , \overline{BLE} HIGH), or during an active write operation (\overline{CE} LOW and \overline{WE} LOW).

Write to the device by taking Chip Enable (\overline{CE}) and Write Enable (\overline{WE}) inputs LOW. If Byte Low Enable (\overline{BLE}) is LOW, then data from I/O pins (I/O₀ through I/O₇) is written into the location specified on the address pins (A₀ through A₁₆). If Byte High Enable (\overline{BHE}) is LOW, then data from I/O pins (I/O₈ through I/O₁₅) is written into the location specified on the address pins (A₀ through A₁₆).

Read from the device by taking Chip Enable (\overline{CE}) and Output Enable (\overline{OE}) LOW, while forcing the Write Enable (\overline{WE}) HIGH. If Byte Low Enable (\overline{BLE}) is LOW, then data from the memory location specified by the address pins appear on I/O₀ to I/O₇. If Byte High Enable (\overline{BHE}) is LOW, then data from memory appears on I/O₈ to I/O₁₅. See the Truth Table on page 11 for a complete description of read and write modes.

For a complete list of related resources, [click here](#).

Logic Block Diagram

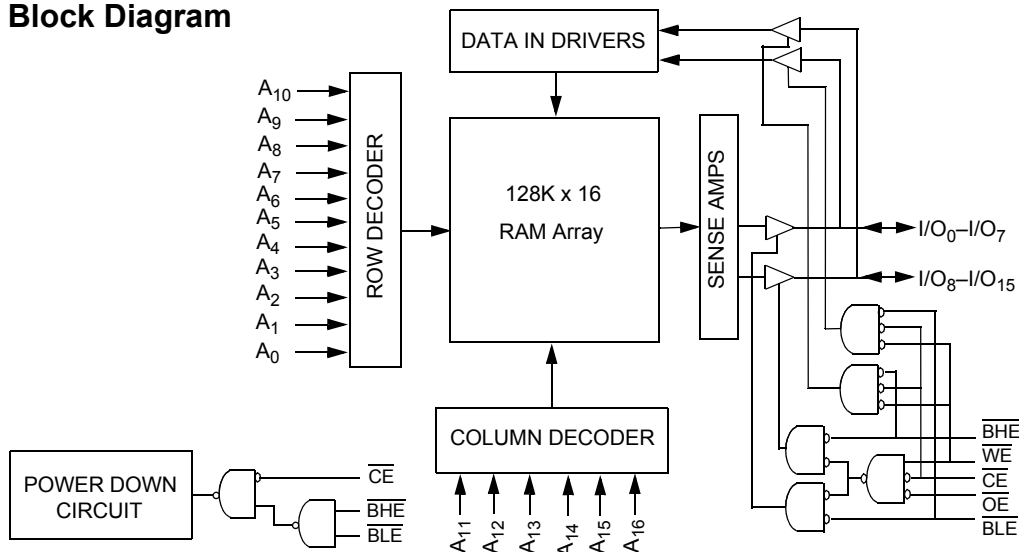

Contents

Product Portfolio	3	Ordering Information	12
Pin Configuration	3	Ordering Code Definitions	12
Maximum Ratings	4	Package Diagrams	13
Operating Range	4	Acronyms	14
Electrical Characteristics	4	Document Conventions	14
Capacitance	5	Units of Measure	14
Thermal Resistance	5	Document History Page	15
AC Test Loads and Waveforms	5	Sales, Solutions, and Legal Information	16
Data Retention Characteristics	6	Worldwide Sales and Design Support	16
Data Retention Waveform	6	Products	16
Switching Characteristics	7	PSoC® Solutions	16
Switching Waveforms	8	Cypress Developer Community	16
Truth Table	11	Technical Support	16

Product Portfolio

Product	Range	V _{CC} Range (V)			Speed (ns)	Power Dissipation					
						Operating I _{CC} (mA)				Standby I _{SB2} (μA)	
		f = 1MHz		f = f _{max}							
		Min	Typ ^[1]	Max		Typ ^[1]	Max	Typ ^[1]	Max	Typ ^[1]	Max
CY62137FV30LL	Automotive-A	2.2 V	3.0 V	3.6 V	45	1.6	2.5	13	18	1	5
	Automotive-E	2.2 V	3.0 V	3.6 V	55	2	3	15	25	1	20

Pin Configuration

Figure 1. 44-pin TSOP II pinout^[2]

A ₄	□ 1	44	□ A ₅
A ₃	□ 2	43	□ A ₆
A ₂	□ 3	42	□ A ₇
A ₁	□ 4	41	□ OE
A ₀	□ 5	40	□ BHE
$\overline{\text{CE}}$	□ 6	39	□ BLE
I/O ₀	□ 7	38	□ I/O ₁₅
I/O ₁	□ 8	37	□ I/O ₁₄
I/O ₂	□ 9	36	□ I/O ₁₃
I/O ₃	□ 10	35	□ I/O ₁₂
V _{CC}	□ 11	34	□ V _{SS}
V _{SS}	□ 12	33	□ V _{CC}
I/O ₄	□ 13	32	□ I/O ₁₁
I/O ₅	□ 14	31	□ I/O ₁₀
I/O ₆	□ 15	30	□ I/O ₉
I/O ₇	□ 16	29	□ I/O ₈
$\overline{\text{WE}}$	□ 17	28	□ NC
A ₁₆	□ 18	27	□ A ₈
A ₁₅	□ 19	26	□ A ₉
A ₁₄	□ 20	25	□ A ₁₀
A ₁₃	□ 21	24	□ A ₁₁
A ₁₂	□ 22	23	□ NC

Notes

1. Typical values are included for reference only and are not guaranteed or tested. Typical values are measured at V_{CC} = V_{CC(typ)}, T_A = 25 °C.
2. NC pins are not connected on the die.

Maximum Ratings

Exceeding the maximum ratings may impair the useful life of the device. These user guidelines are not tested.

Storage temperature	-65 °C to + 150 °C
Ambient temperature with power applied	-55 °C to + 125 °C
Supply voltage to ground potential [3, 4]	-0.3 V to 3.9 V
DC voltage applied to outputs in High Z state [3, 4]	-0.3 V to 3.9 V
DC input voltage [3, 4]	-0.3 V to 3.9 V

Output current into outputs (LOW)	20 mA
Static discharge voltage (MIL-STD-883, method 3015)	> 2001 V
Latch up current	> 200 mA

Operating Range

Device	Range	Ambient Temperature	V _{CC} [5]
CY62137FV30LL	Automotive-A	-40 °C to +85 °C	2.2 V to 3.6 V
	Automotive-E	-40 °C to +125 °C	3.6 V

Electrical Characteristics

Over the Operating Range

Parameter	Description	Test Conditions	45 ns (Automotive-A)			55 ns (Automotive-E)			Unit	
			Min	Typ [6]	Max	Min	Typ [6]	Max		
V _{OH}	Output high voltage	2.2 ≤ V _{CC} ≤ 2.7	I _{OH} = -0.1 mA	2.0	-	-	2.0	-	-	V
		2.7 ≤ V _{CC} ≤ 3.6	I _{OH} = -1.0 mA	2.4	-	-	2.4	-	-	V
V _{OL}	Output low voltage	2.2 ≤ V _{CC} ≤ 2.7	I _{OL} = 0.1 mA	-	-	0.4	-	-	0.4	V
		2.7 ≤ V _{CC} ≤ 3.6	I _{OL} = 2.1 mA	-	-	0.4	-	-	0.4	V
V _{IH}	Input high voltage	2.2 ≤ V _{CC} ≤ 2.7		1.8	-	V _{CC} + 0.3	1.8	-	V _{CC} + 0.3	V
		2.7 ≤ V _{CC} ≤ 3.6		2.2	-	V _{CC} + 0.3	2.2	-	V _{CC} + 0.3	V
V _{IL}	Input low voltage	2.2 ≤ V _{CC} ≤ 2.7		-0.3	-	0.6	-0.3	-	0.6	V
		2.7 ≤ V _{CC} ≤ 3.6		-0.3	-	0.8	-0.3	-	0.8	V
I _{IX}	Input leakage current	GND ≤ V _I ≤ V _{CC}		-1	-	+1	-4	-	+4	μA
I _{OZ}	Output leakage current	GND ≤ V _O ≤ V _{CC} , Output disabled		-1	-	+1	-4	-	+4	μA
I _{CC}	V _{CC} operating supply current	f = f _{max} = 1/t _{RC}	V _{CC} = V _{CC(max)}	-	13	18	-	15	25	mA
		f = 1 MHz	I _{OUT} = 0 mA CMOS levels	-	1.6	2.5	-	2	3	
I _{SB1} [7]	Automatic power down current – CMOS inputs	$\overline{CE} \geq V_{CC} - 0.2 \text{ V}$ or $(\overline{BHE} \text{ and } \overline{BLE}) \geq V_{CC} - 0.2 \text{ V}$, $V_{IN} \geq V_{CC} - 0.2 \text{ V}$, $V_{IN} \leq 0.2 \text{ V}$, $f = f_{max}$ (address and data only), $f = 0$ (\overline{OE} and \overline{WE}), $V_{CC} = V_{CC(max)}$		-	1	5	-	1	20	μA
I _{SB2} [7]	Automatic power down current – CMOS inputs	$\overline{CE} \geq V_{CC} - 0.2 \text{ V}$ or $(\overline{BHE} \text{ and } \overline{BLE}) \geq V_{CC} - 0.2 \text{ V}$, $V_{IN} \geq V_{CC} - 0.2 \text{ V}$ or $V_{IN} \leq 0.2 \text{ V}$, $f = 0$, $V_{CC} = V_{CC(max)}$		-	1	5	-	1	20	μA

Notes

- V_{IL(min)} = -2.0 V for pulse durations less than 20 ns.
- V_{IH(max)} = V_{CC} + 0.75 V for pulse durations less than 20 ns.
- Full device AC operation assumes a minimum of 100 μs ramp time from 0 to V_{CC(min)} and 200 μs wait time after V_{CC} stabilization.
- Typical values are included for reference only and are not guaranteed or tested. Typical values are measured at V_{CC} = V_{CC(typ)}, T_A = 25 °C.
- Chip enable (CE) and byte enables (BHE and BLE) need to be tied to CMOS levels to meet the I_{SB1} / I_{SB2} / I_{CCDR} specification. Other inputs can be left floating.

Capacitance

Parameter ^[8]	Description	Test Conditions	Max	Unit
C _{IN}	Input capacitance	T _A = 25 °C, f = 1 MHz, V _{CC} = V _{CC(typ)}	10	pF
C _{OUT}	Output capacitance		10	pF

Thermal Resistance

Parameter ^[8]	Description	Test Conditions	TSOP II	Unit
Θ _{JA}	Thermal resistance (junction to ambient)	Still air, soldered on a 3 × 4.5 inch, four-layer printed circuit board	57.92	°C/W
Θ _{JC}	Thermal resistance (junction to case)		17.44	°C/W

AC Test Loads and Waveforms

Figure 2. AC Test Loads and Waveforms

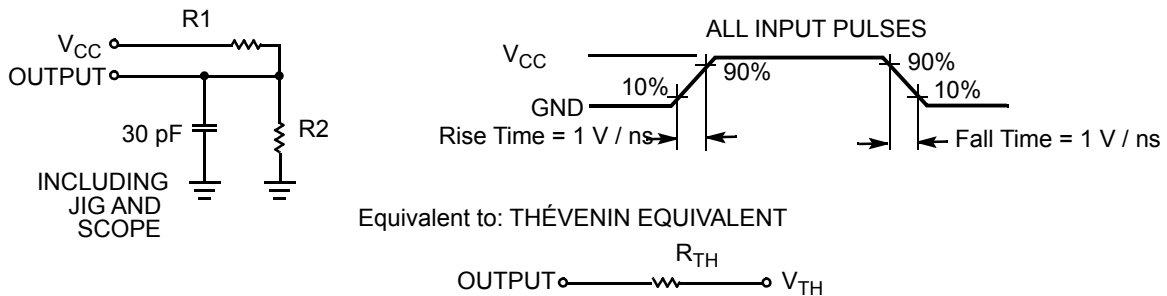

Parameters	2.5 V (2.2 V to 2.7 V)	3.0 V (2.7 V to 3.6 V)	Unit
R1	16667	1103	Ω
R2	15385	1554	Ω
R _{TH}	8000	645	Ω
V _{TH}	1.20	1.75	V

Note

8. Tested initially and after any design or process changes that may affect these parameters.

Data Retention Characteristics

Over the Operating Range

Parameter	Description	Conditions	Min	Typ ^[9]	Max	Unit
V_{DR}	V_{CC} for data retention		1.5	–	–	V
I_{CCDR} ^[10]	Data retention current	$V_{CC} = 1.5\text{ V}$, $\overline{CE} \geq V_{CC} - 0.2\text{ V}$ or $(\overline{BHE}$ and $\overline{BLE}) \geq V_{CC} - 0.2\text{ V}$ $V_{IN} \geq V_{CC} - 0.2\text{ V}$ or $V_{IN} \leq 0.2\text{ V}$	Automotive-A	–	4	μA
			Automotive-E	–	–	12
t_{CDR} ^[11]	Chip deselect to data retention time		0	–	–	ns
t_R ^[12]	Operation recovery time					
		CY62137FV30LL-45	45	–	–	ns
		CY62137FV30LL-55	55	–	–	ns

Data Retention Waveform

Figure 3. Data Retention Waveform^[13]

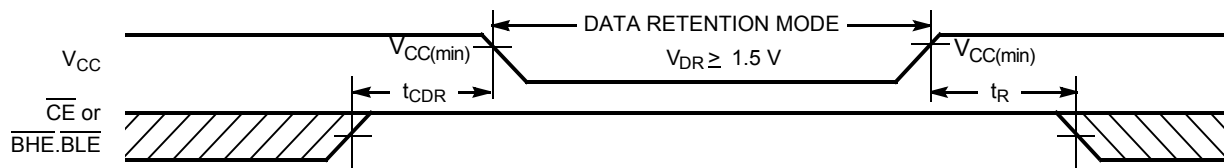

Notes

9. Typical values are included for reference only and are not guaranteed or tested. Typical values are measured at $V_{CC} = V_{CC(typ)}$, $T_A = 25\text{ }^\circ\text{C}$
10. Chip enable (\overline{CE}) and byte enables (\overline{BHE} and \overline{BLE}) need to be tied to CMOS levels to meet the I_{SB1} / I_{SB2} / I_{CCDR} specification. Other inputs can be left floating.
11. Tested initially and after any design or process changes that may affect these parameters.
12. Full device operation requires linear V_{CC} ramp from V_{DR} to $V_{CC(min)} \geq 100\text{ }\mu\text{s}$ or stable at $V_{CC(min)} \geq 100\text{ }\mu\text{s}$.
13. $\overline{BHE.BLE}$ is the AND of both \overline{BHE} and \overline{BLE} . Deselect the chip by either disabling chip enable signals or by disabling both \overline{BHE} and \overline{BLE} .

Switching Characteristics

Parameter ^[14, 15]	Description	45 ns (Automotive-A)		55 ns (Automotive-E)		Unit
		Min	Max	Min	Max	
Read Cycle						
t _{RC}	Read cycle time	45	–	55	–	ns
t _{AA}	Address to data valid	–	45	–	55	ns
t _{OHA}	Data hold from address change	10	–	10	–	ns
t _{ACE}	\overline{CE} LOW to data valid	–	45	–	55	ns
t _{DOE}	\overline{OE} LOW to data valid	–	22	–	25	ns
t _{LZOE}	\overline{OE} LOW to low Z ^[16]	5	–	5	–	ns
t _{HZOE}	\overline{OE} HIGH to high Z ^[16, 17]	–	18	–	20	ns
t _{LZCE}	\overline{CE} LOW to low Z ^[16]	10	–	10	–	ns
t _{HZCE}	\overline{CE} HIGH to high Z ^[16, 17]	–	18	–	20	ns
t _{PU}	\overline{CE} LOW to power-up	0	–	0	–	ns
t _{PD}	\overline{CE} HIGH to power-down	–	45	–	55	ns
t _{DBE}	$\overline{BLE/BHE}$ LOW to data valid	–	45	–	55	ns
t _{LZBE}	$\overline{BLE/BHE}$ LOW to low Z ^[16, 18]	5	–	10	–	ns
t _{HZBE}	$\overline{BLE/BHE}$ HIGH to high Z ^[16, 17]	–	18	–	20	ns
Write Cycle ^[19, 20]						
t _{WC}	Write cycle time	45	–	55	–	ns
t _{SCE}	\overline{CE} LOW to write end	35	–	40	–	ns
t _{AW}	Address setup to write end	35	–	40	–	ns
t _{HA}	Address hold from write end	0	–	0	–	ns
t _{SA}	Address setup to write start	0	–	0	–	ns
t _{PWE}	\overline{WE} pulse width	35	–	40	–	ns
t _{BW}	$\overline{BLE/BHE}$ LOW to write end	35	–	40	–	ns
t _{SD}	Data setup to write end	25	–	25	–	ns
t _{HD}	Data hold from write end	0	–	0	–	ns
t _{HZWE}	\overline{WE} LOW to high Z ^[16, 17]	–	18	–	20	ns
t _{LZWE}	\overline{WE} HIGH to low Z ^[16]	10	–	10	–	ns

Notes

14. Test conditions for all parameters, other than tristate parameters, assume signal transition time of 3 ns (1 V/ns) or less, timing reference levels of $V_{CC(typ)}/2$, input pulse levels of 0 to $V_{CC(typ)}$, and output loading of the specified I_{OL}/I_{OH} as shown in Figure 2 on page 5.
15. AC timing parameters are subject to byte enable signals (BHE or BLE) not switching when chip is disabled. Please see application note AN13842 for further clarification.
16. At any temperature and voltage condition, t_{HZCE} is less than t_{LZCE}, t_{HZBE} is less than t_{LZBE}, t_{HZOE} is less than t_{LZOE}, and t_{HZWE} is less than t_{LZWE} for any device.
17. t_{HZOE}, t_{HZCE}, t_{HZBE}, and t_{HZWE} transitions are measured when the outputs enter a high impedance state.
18. If both byte enables are toggled together, this value is 10 ns.
19. The internal write time of the memory is defined by the overlap of \overline{WE} , $\overline{CE} = V_{IL}$, \overline{BHE} and/or $\overline{BLE} = V_{IL}$. All signals are ACTIVE to initiate a write and any of these signals terminate a write by going INACTIVE. The data input setup and hold timing are referenced to the edge of the signal that terminates the write.
20. The minimum write cycle pulse width required for the Write Cycle No. 3 (WE Controlled, OE LOW) should be equal to sum of t_{SD} and t_{HZWE}.

Switching Waveforms

Figure 4. Read Cycle 1: Address Transition Controlled [21, 22]

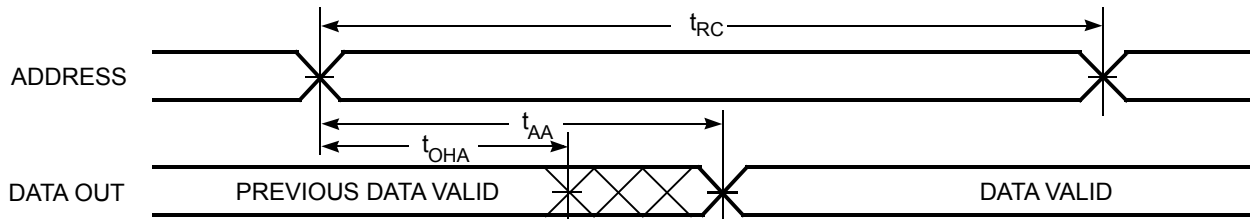
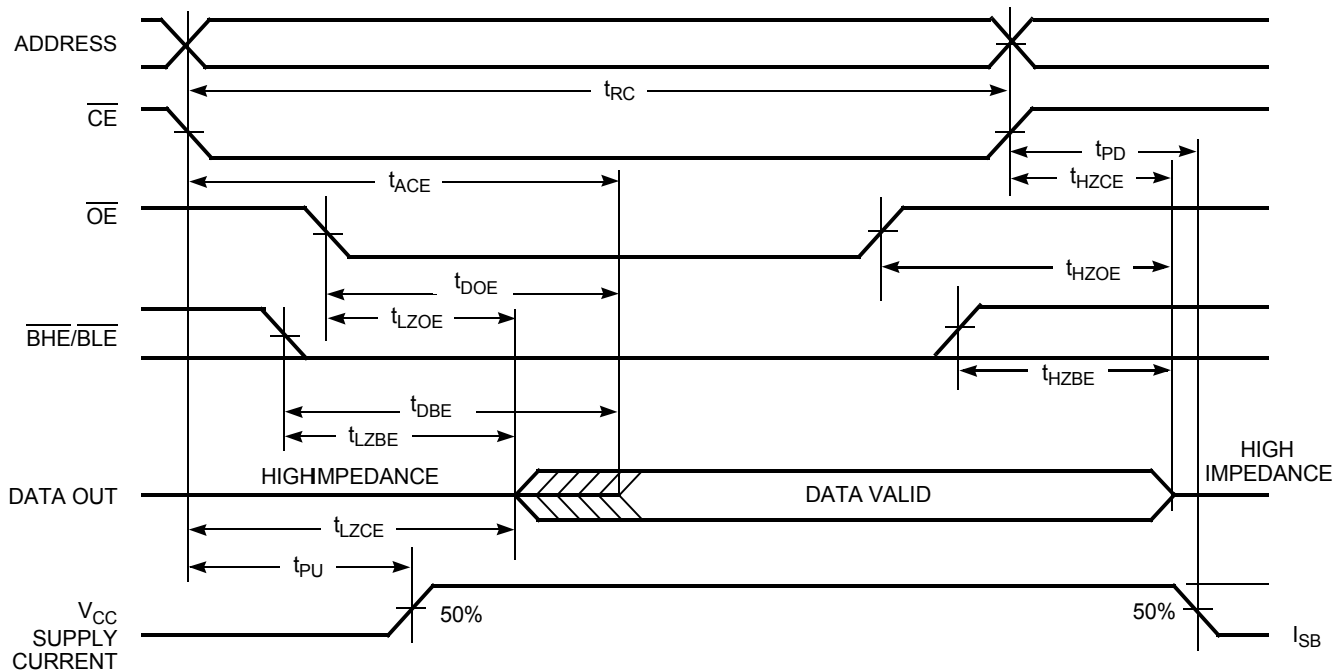

Figure 5. Read Cycle 2: $\overline{\text{OE}}$ Controlled [22, 23]



Notes

21. The device is continuously selected. $\overline{\text{OE}}$, $\overline{\text{CE}} = V_{\text{IL}}$, $\overline{\text{BHE}}$ and/or $\overline{\text{BLE}} = V_{\text{IL}}$.

22. $\overline{\text{WE}}$ is HIGH for read cycle.

23. Address valid before or similar to $\overline{\text{CE}}$ and $\overline{\text{BHE}}$, $\overline{\text{BLE}}$ transition LOW.

Switching Waveforms (continued)

Figure 6. Write Cycle 1: \overline{WE} Controlled [24, 25, 26]

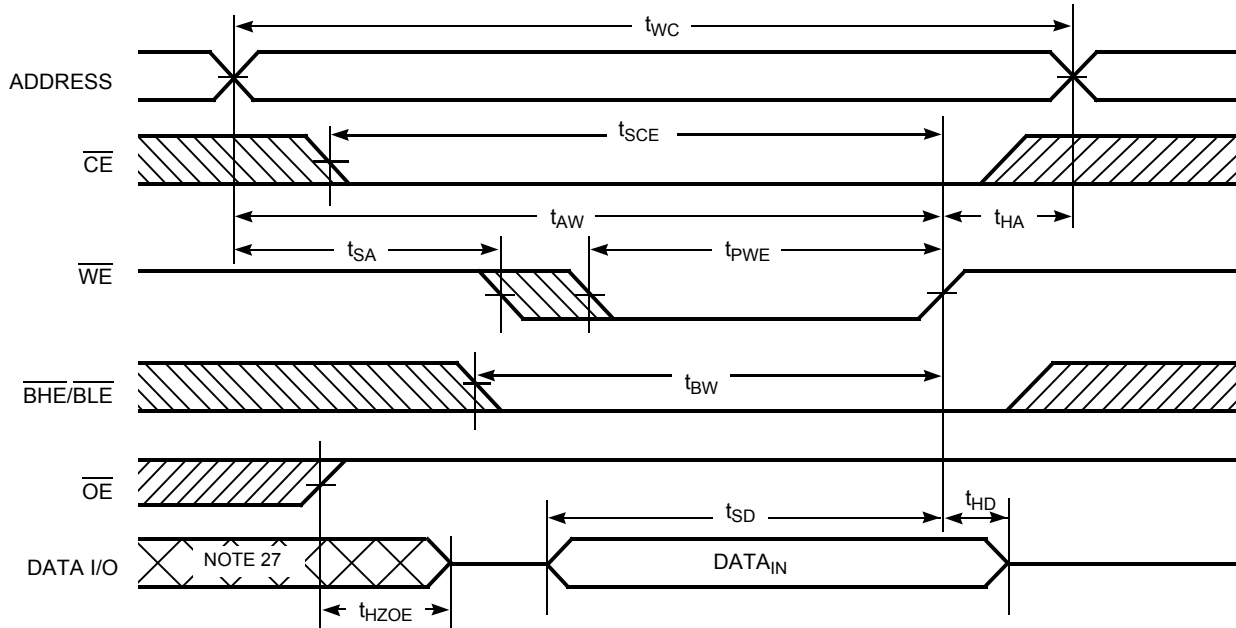
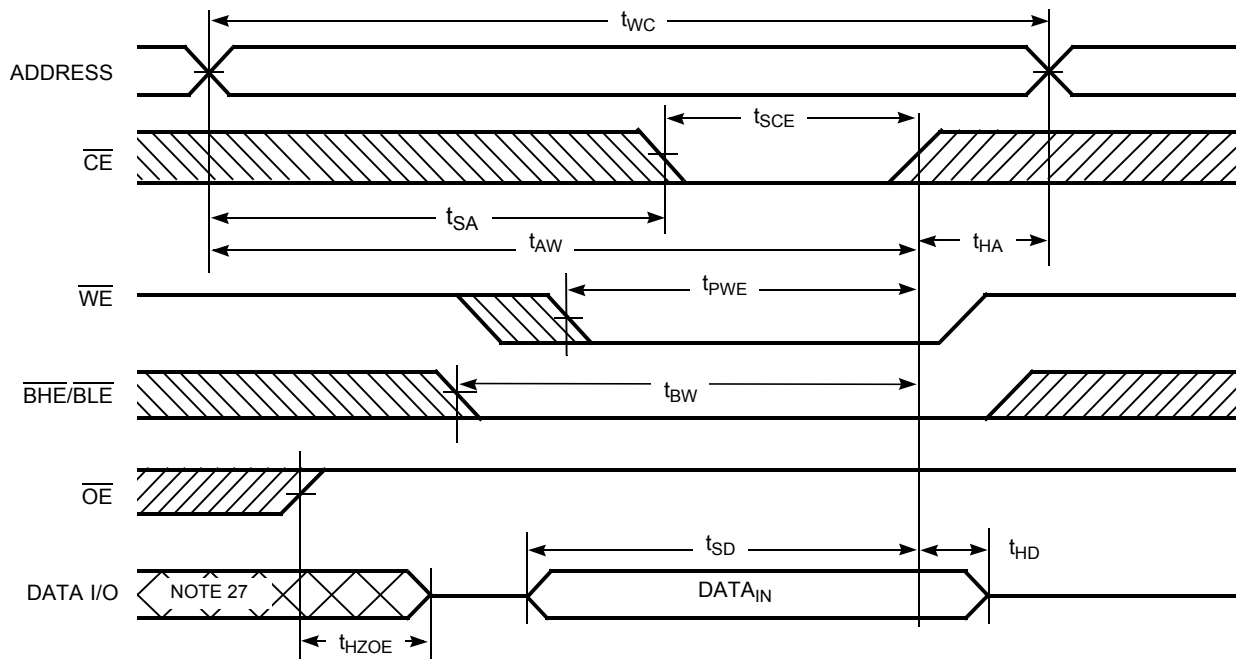

Figure 7. Write Cycle 2: \overline{CE} Controlled [24, 25, 26]



Notes

24. The internal write time of the memory is defined by the overlap of \overline{WE} , $\overline{CE} = V_{IL}$, \overline{BHE} and/or $\overline{BLE} = V_{IL}$. All signals are ACTIVE to initiate a write and any of these signals terminate a write by going INACTIVE. The data input setup and hold timing are referenced to the edge of the signal that terminates the write.

25. Data I/O is high impedance if $OE = V_{IH}$.

26. If \overline{CE} goes HIGH simultaneously with $WE = V_{IH}$, the output remains in a high impedance state.

27. During this period, the I/Os are in output state. Do not apply input signals.

Switching Waveforms (continued)

Figure 8. Write Cycle 3: \overline{WE} Controlled, \overline{OE} LOW [28, 29]

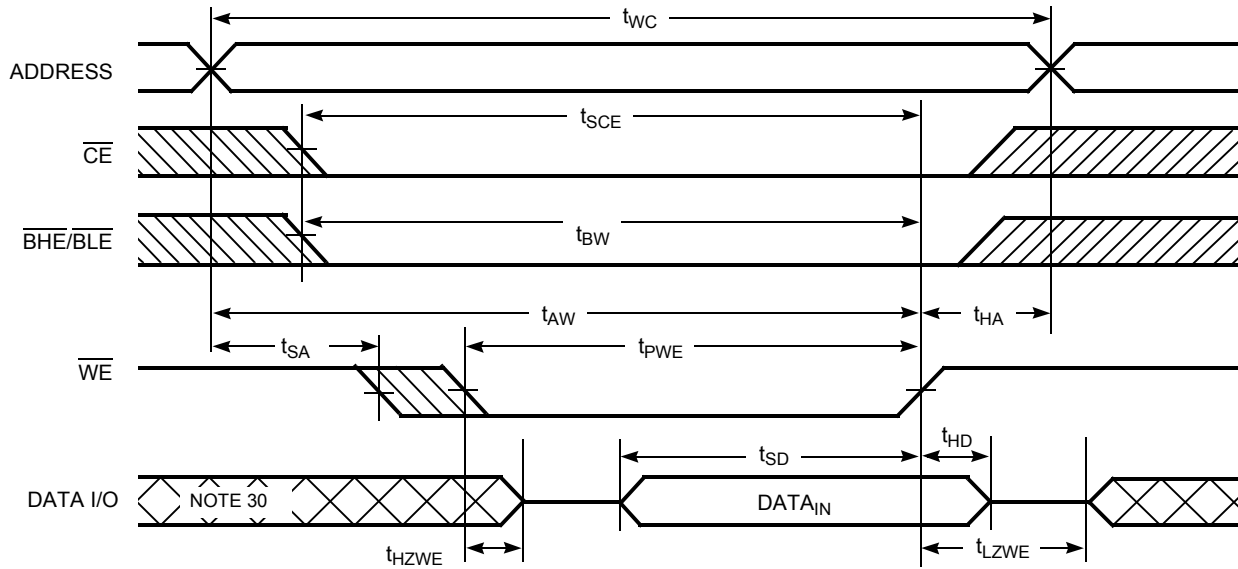
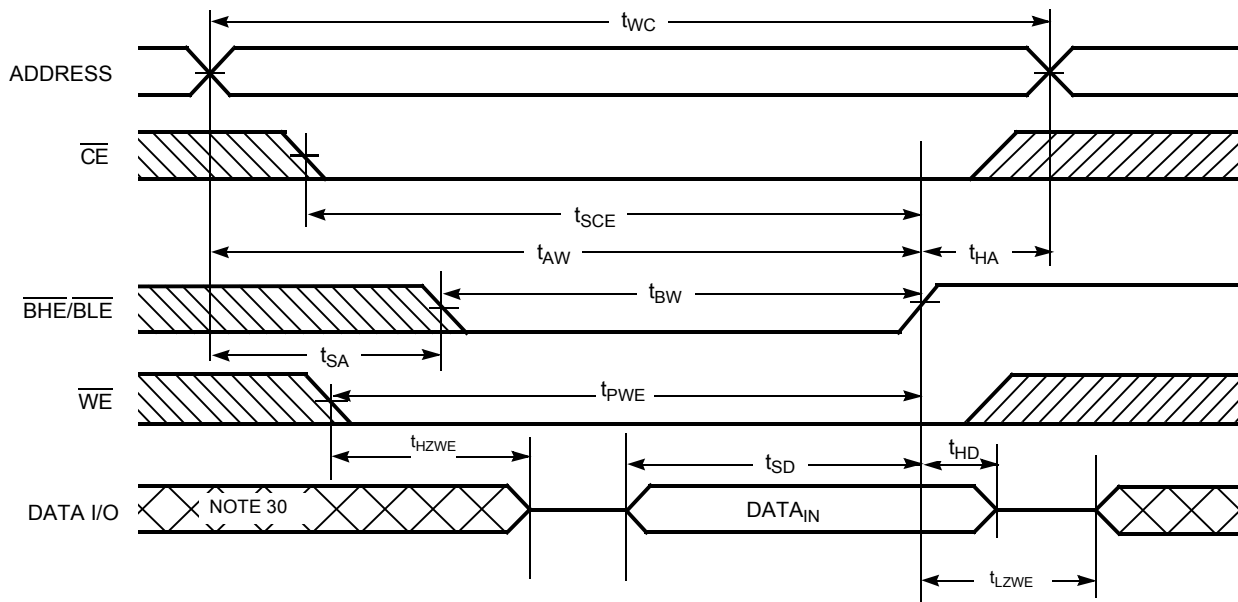

Figure 9. Write Cycle 4: $\overline{BHE}/\overline{BLE}$ Controlled, \overline{OE} LOW [28]



Notes

- 28. If \overline{CE} goes HIGH simultaneously with $\overline{WE} = V_{IH}$, the output remains in a high impedance state.
- 29. The minimum write cycle pulse width should be equal to sum of t_{SD} and t_{HZWE} .
- 30. During this period, the I/Os are in output state. Do not apply input signals.

Truth Table

CE	WE	OE	BHE	BLE	Inputs or Outputs	Mode	Power
H	X	X	X ^[31]	X ^[31]	High Z	Deselect or power-down	Standby (I _{SB})
X ^[31]	X	X	H	H	High Z	Deselect or power-down	Standby (I _{SB})
L	H	L	L	L	Data out (I/O ₀ –I/O ₁₅)	Read	Active (I _{CC})
L	H	L	H	L	Data out (I/O ₀ –I/O ₇); I/O ₈ –I/O ₁₅ in High Z	Read	Active (I _{CC})
L	H	L	L	H	Data out (I/O ₈ –I/O ₁₅); I/O ₀ –I/O ₇ in High Z	Read	Active (I _{CC})
L	H	H	L	L	High Z	Output disabled	Active (I _{CC})
L	H	H	H	L	High Z	Output disabled	Active (I _{CC})
L	H	H	L	H	High Z	Output disabled	Active (I _{CC})
L	L	X	L	L	Data in (I/O ₀ –I/O ₁₅)	Write	Active (I _{CC})
L	L	X	H	L	Data in (I/O ₀ –I/O ₇); I/O ₈ –I/O ₁₅ in High Z	Write	Active (I _{CC})
L	L	X	L	H	Data in (I/O ₈ –I/O ₁₅); I/O ₀ –I/O ₇ in High Z	Write	Active (I _{CC})

Note

31. The 'X' (Don't care) state for the Chip enable ($\overline{\text{CE}}$) and Byte enables ($\overline{\text{BHE}}$ and $\overline{\text{BLE}}$) in the truth table refer to the logic state (either HIGH or LOW). Intermediate voltage levels on these pins is not permitted.

Ordering Information

Speed (ns)	Ordering Code	Package Diagram	Package Type	Operating Range
45	CY62137FV30LL-45ZSXA	51-85087	44-pin TSOP II (Pb-free)	Automotive-A
55	CY62137FV30LL-55ZSXE			Automotive-E

Contact your local Cypress sales representative for availability of these parts.

Ordering Code Definitions

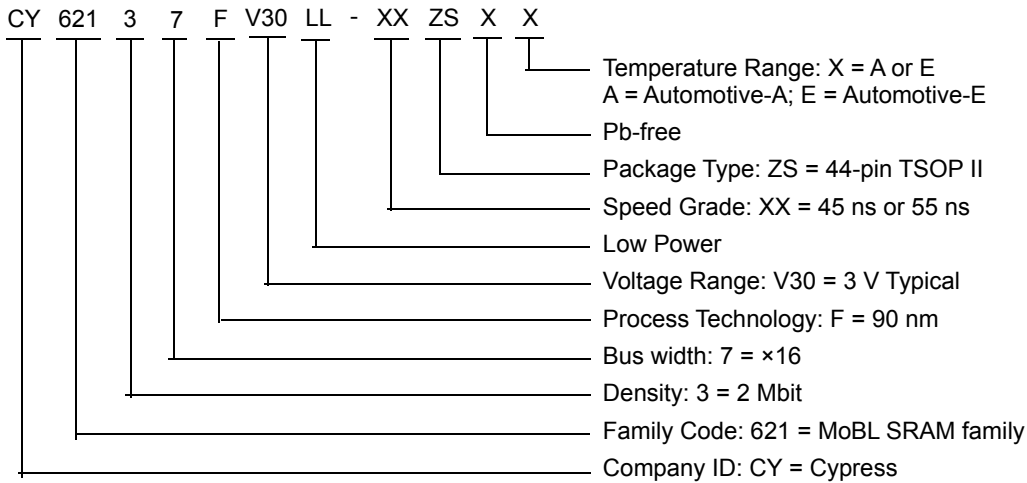

Package Diagrams

Figure 10. 44-pin TSOP Z44-II Package Outline, 51-85087

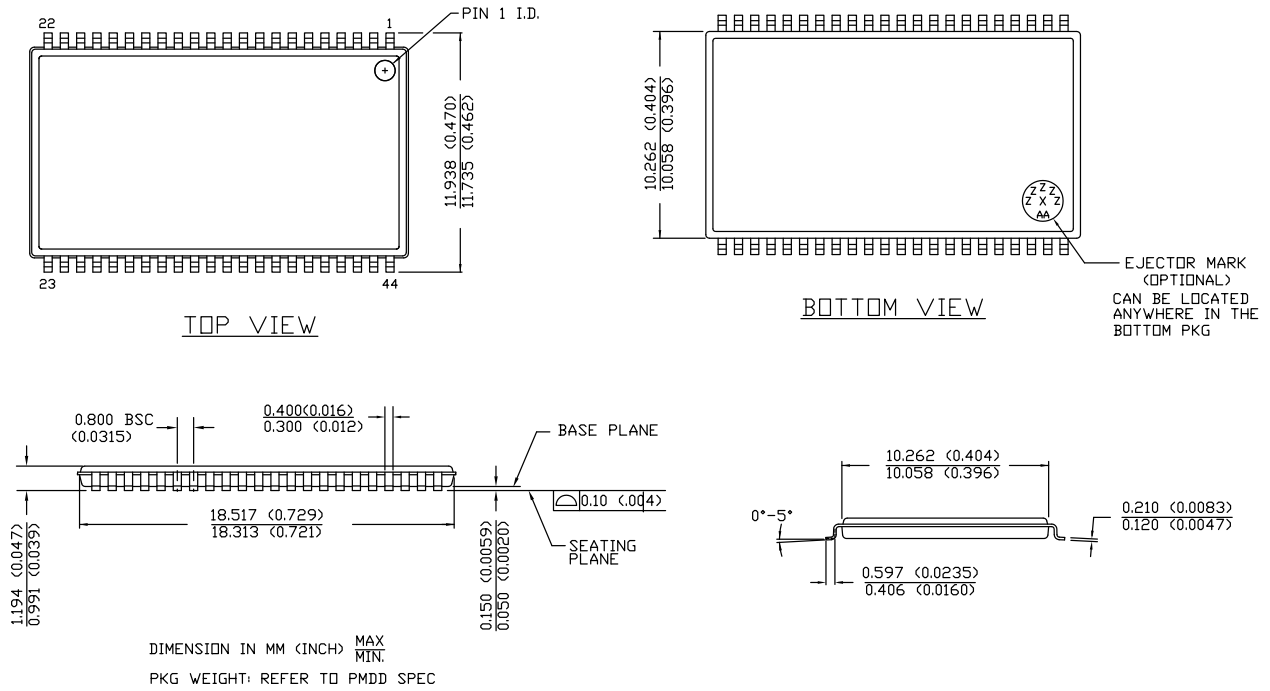

51-85087 *E

Acronyms

Acronym	Description
$\overline{\text{BHE}}$	Byte High Enable
$\overline{\text{BLE}}$	Byte Low Enable
$\overline{\text{CE}}$	Chip Enable
CMOS	Complementary Metal Oxide Semiconductor
I/O	Input/Output
$\overline{\text{OE}}$	Output Enable
SRAM	Static Random Access Memory
TSOP	Thin Small Outline Package
$\overline{\text{WE}}$	Write Enable

Document Conventions

Units of Measure

Symbol	Unit of Measure
°C	degree Celsius
MHz	megahertz
μA	microampere
μs	microsecond
mA	milliampere
ns	nanosecond
Ω	ohm
pF	picofarad
V	volt
W	watt

Document History Page

Document Title: CY62137FV30 MoBL [®] Automotive, 2-Mbit (128 K × 16) Static RAM				
Document Number: 001-66190				
Rev.	ECN No.	Issue Date	Orig. of Change	Description of Change
**	3124003	01/12/2011	RAME	Created new Automotive datasheet from document number 001-07141 Rev. *H
*A	3503362	01/20/2012	TAVA	Updated Functional Description . Updated Package Diagrams . Updated to new template.
*B	4250476	01/17/2014	VINI	Updated Package Diagrams : spec 51-85087 – Changed revision from *D to *E. Updated to new template. Completing Sunset Review.
*C	4658311	02/11/2015	VINI	Updated Maximum Ratings : Referred Notes 3, 4 in “Supply voltage to ground potential”. Referred Note 3 in “DC input voltage”. Updated AC Test Loads and Waveforms : Updated Figure 2 . Updated Switching Characteristics : Added Note 20 and referred the same note in “Write Cycle”. Updated Switching Waveforms : Added Note 29 and referred the same note in Figure 8 . Completing Sunset Review.
*D	4729375	06/05/2015	PSR	Updated Functional Description : Added “For a complete list of related resources, click here .” at the end. Updated Thermal Resistance : Replaced “two layer” with “four-layer” in “Test Conditions” column. Changed value of Θ_{JA} parameter from 77 °C/W to 57.92 °C/W. Changed value of Θ_{JC} parameter from 13 °C/W to 17.44 °C/W. Updated to new template.
*E	6007662	01/03/2018	AESATP12	Updated logo and copyright.

Sales, Solutions, and Legal Information

Worldwide Sales and Design Support

Cypress maintains a worldwide network of offices, solution centers, manufacturer's representatives, and distributors. To find the office closest to you, visit us at [Cypress Locations](#).

Products

Arm® Cortex® Microcontrollers	cypress.com/arm
Automotive	cypress.com/automotive
Clocks & Buffers	cypress.com/clocks
Interface	cypress.com/interface
Internet of Things	cypress.com/iot
Memory	cypress.com/memory
Microcontrollers	cypress.com/mcu
PSoC	cypress.com/psoc
Power Management ICs	cypress.com/pmic
Touch Sensing	cypress.com/touch
USB Controllers	cypress.com/usb
Wireless Connectivity	cypress.com/wireless

PSoC® Solutions

[PSoC 1](#) | [PSoC 3](#) | [PSoC 4](#) | [PSoC 5LP](#) | [PSoC 6 MCU](#)

Cypress Developer Community

[Community](#) | [Projects](#) | [Video](#) | [Blogs](#) | [Training](#) | [Components](#)

Technical Support

cypress.com/support



© Cypress Semiconductor Corporation, 2011-2018. This document is the property of Cypress Semiconductor Corporation and its subsidiaries, including Spansion LLC ("Cypress"). This document, including any software or firmware included or referenced in this document ("Software"), is owned by Cypress under the intellectual property laws and treaties of the United States and other countries worldwide. Cypress reserves all rights under such laws and treaties and does not, except as specifically stated in this paragraph, grant any license under its patents, copyrights, trademarks, or other intellectual property rights. If the Software is not accompanied by a license agreement and you do not otherwise have a written agreement with Cypress governing the use of the Software, then Cypress hereby grants you a personal, non-exclusive, nontransferable license (without the right to sublicense) (1) under its copyright rights in the Software (a) for Software provided in source code form, to modify and reproduce the Software solely for use with Cypress hardware products, only internally within your organization, and (b) to distribute the Software in binary code form externally to end users (either directly or indirectly through resellers and distributors), solely for use on Cypress hardware product units, and (2) under those claims of Cypress's patents that are infringed by the Software (as provided by Cypress, unmodified) to make, use, distribute, and import the Software solely for use with Cypress hardware products. Any other use, reproduction, modification, translation, or compilation of the Software is prohibited.

TO THE EXTENT PERMITTED BY APPLICABLE LAW, CYPRESS MAKES NO WARRANTY OF ANY KIND, EXPRESS OR IMPLIED, WITH REGARD TO THIS DOCUMENT OR ANY SOFTWARE OR ACCOMPANYING HARDWARE, INCLUDING, BUT NOT LIMITED TO, THE IMPLIED WARRANTIES OF MERCHANTABILITY AND FITNESS FOR A PARTICULAR PURPOSE. No computing device can be absolutely secure. Therefore, despite security measures implemented in Cypress hardware or software products, Cypress does not assume any liability arising out of any security breach, such as unauthorized access to or use of a Cypress product. In addition, the products described in these materials may contain design defects or errors known as errata which may cause the product to deviate from published specifications. To the extent permitted by applicable law, Cypress reserves the right to make changes to this document without further notice. Cypress does not assume any liability arising out of the application or use of any product or circuit described in this document. Any information provided in this document, including any sample design information or programming code, is provided only for reference purposes. It is the responsibility of the user of this document to properly design, program, and test the functionality and safety of any application made of this information and any resulting product. Cypress products are not designed, intended, or authorized for use as critical components in systems designed or intended for the operation of weapons, weapons systems, nuclear installations, life-support devices or systems, other medical devices or systems (including resuscitation equipment and surgical implants), pollution control or hazardous substances management, or other uses where the failure of the device or system could cause personal injury, death, or property damage ("Unintended Uses"). A critical component is any component of a device or system whose failure to perform can be reasonably expected to cause the failure of the device or system, or to affect its safety or effectiveness. Cypress is not liable, in whole or in part, and you shall and hereby do release Cypress from any claim, damage, or other liability arising from or related to all Unintended Uses of Cypress products. You shall indemnify and hold Cypress harmless from and against all claims, costs, damages, and other liabilities, including claims for personal injury or death, arising from or related to any Unintended Uses of Cypress products.

Cypress, the Cypress logo, Spansion, the Spansion logo, and combinations thereof, WICED, PSoC, CapSense, EZ-USB, F-RAM, and Traveo are trademarks or registered trademarks of Cypress in the United States and other countries. For a more complete list of Cypress trademarks, visit cypress.com. Other names and brands may be claimed as property of their respective owners.

Looking for pricing, stock, or lifecycle information?

Click below to explore more details on WIN SOURCE:

-  [View CY62137FV30LL-55ZSXET on WIN SOURCE](#)
-  [Cypress Semiconductor Corp Information](#)

Optimize Your Supply Chain with WIN SOURCE Solutions

-  Global Sourcing Solution
-  Obsolete Management
-  Cost Control Management
-  Shortage Management
-  Alternative Solution
-  Excess Inventory Management