



**THE DATASHEET OF
CY14V101Q3-SFXI**



1 Mbit (128 K × 8) Serial SPI nvSRAM

Features

- 1-Mbit nonvolatile static random access memory (nvSRAM)
 - Internally organized as 128 K × 8
 - STORE to QuantumTrap nonvolatile elements initiated automatically on power-down (AutoStore) or by user using HSB pin (Hardware STORE) or SPI instruction (Software STORE)
 - RECALL to SRAM initiated on power-up (Power-Up RECALL) or by SPI instruction (Software RECALL)
 - Automatic STORE on power-down with a small capacitor
- High reliability
 - Infinite read, write, and RECALL cycles
 - 1 million STORE cycles to QuantumTrap
 - Data retention: 20 years
- High speed serial peripheral interface (SPI)
 - 30 MHz clock rate
 - Supports SPI mode 0 (0,0) and mode 3 (1,1)
- Write protection
 - Hardware protection using Write Protect (\overline{WP}) pin
 - Software protection using Write Disable instruction
 - Software block protection for 1/4, 1/2, or entire array

- Low power consumption
 - Core V_{CC} = 3.0 V to 3.6 V; I/O V_{CCQ} = 1.65 V to 1.95 V
 - Average active current of 10 mA at 30 MHz operation
- Industry standard configurations
 - Industrial temperature
 - 16-pin small outline integrated circuit (SOIC) package
 - Restriction of hazardous substances (RoHS) compliant

Functional Overview

The Cypress CY14V101Q3 combines a 1 Mbit nvSRAM with a nonvolatile element in each memory cell with serial SPI interface. The memory is organized as 128 K words of 8 bits each. The embedded nonvolatile elements incorporate the QuantumTrap technology, creating the world's most reliable nonvolatile memory. The SRAM provides infinite read and write cycles, while the QuantumTrap cell provides highly reliable nonvolatile storage of data. Data transfers from SRAM to the nonvolatile elements (STORE operation) takes place automatically at power-down. On power-up, data is restored to the SRAM from the nonvolatile memory (RECALL operation). Both STORE and RECALL operations can also be initiated by the user through SPI instruction.

For a complete list of related documentation, click [here](#).

Logic Block Diagram

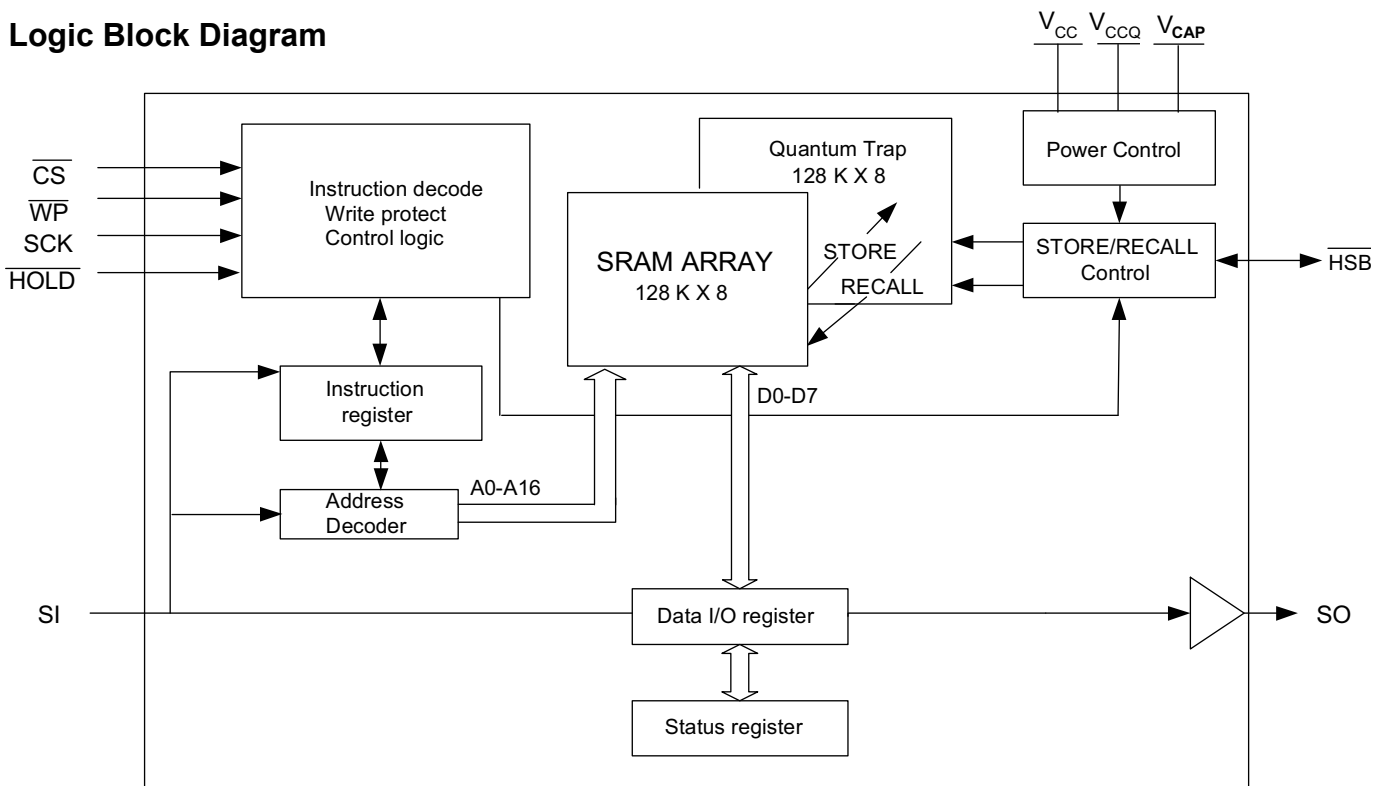

Contents

Pinouts	3	Memory Access	11
Device Operation	4	Read Sequence (READ) instruction	11
SRAM Write	4	Write Sequence (WRITE) instruction	11
SRAM Read	4	Software STORE (STORE) instruction	13
STORE Operation	4	Software RECALL (RECALL) instruction	13
AutoStore Operation	5	AutoStore Enable (ASENB) instruction	13
Software STORE Operation	5	AutoStore Disable (ASDISB) instruction	13
Hardware STORE and HSB Pin Operation	5	HOLD Pin Operation	14
RECALL Operation	5	Best Practices	14
Hardware RECALL (Power-Up)	5	Maximum Ratings	15
Software RECALL	5	DC Electrical Characteristics	15
Disabling and Enabling AutoStore	5	Data Retention and Endurance	16
Noise Considerations	6	Capacitance	16
Serial Peripheral Interface	6	Thermal Resistance	16
SPI Overview	6	AC Test Conditions	16
SPI Modes	7	AC Switching Characteristics	17
SPI Operating Features	8	AutoStore or Power-Up RECALL	18
Power-Up	8	Software Controlled STORE and RECALL Cycles	19
Power On Reset	8	Hardware STORE Cycle	20
Power-Down	8	Ordering Information	21
Active Power and Standby Power Modes	8	Ordering Code Definition	21
SPI Functional Description	8	Package Diagrams	22
Status Register	9	Acronyms	23
Read Status Register (RDSR) Instruction	9	Document Conventions	23
Write Status Register (WRSR) Instruction	9	Units of Measure	23
Write Protection and Block Protection	10	Document History Page	24
Write Enable (WREN) Instruction	10	Sales, Solutions, and Legal Information	24
Write Disable (WRDI) Instruction	10	Worldwide Sales and Design Support	24
Block Protection	10	Products	24
Write Protect (WP) Pin	11	PSoC Solutions	24

Pinouts

Figure 1. Pin Diagram – 16-pin SOIC

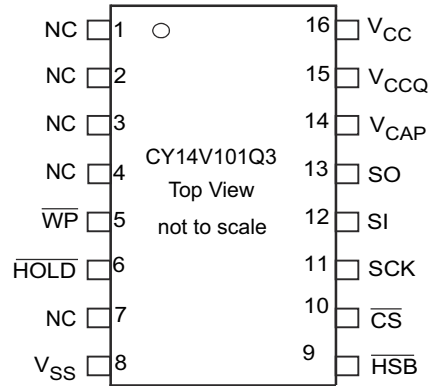

Table 1. Pin Definitions

Pin Name	I/O Type	Description
\overline{CS}	Input	Chip select. Activates the device when pulled LOW. Driving this pin high puts the device in low power standby mode.
SCK	Input	Serial clock. Runs at speeds up to maximum of f_{SCK} . Serial input is latched at the rising edge of this clock. Serial output is driven at the falling edge of the clock.
SI	Input	Serial input. Pin for input of all SPI instructions and data.
SO	Output	Serial output. Pin for output of data through SPI.
\overline{WP}	Input	Write protect. Implements hardware write protection in SPI.
\overline{HOLD}	Input	\overline{HOLD} pin. suspends serial operation.
\overline{HSB}	Input/Output	Output: Indicates busy status of nvSRAM when LOW. After each Hardware and Software STORE operation HSB is driven HIGH for a short time (t_{HHHD}) with standard output high current and then a weak internal pull-up resistor keeps this pin HIGH (External pull-up resistor connection optional). Input: Hardware STORE implemented by pulling this pin LOW externally.
V_{CAP}	Power supply	AutoStore capacitor. Supplies power to the nvSRAM during power loss to STORE data from the SRAM to nonvolatile elements. If AutoStore is not needed, this pin must be left as No connect. It must never be connected to V_{SS} .
NC	No connect	No connect: This pin is not connected to the die.
V_{SS}	Power supply	Ground
V_{CC}	Power supply	Power supply (3.0 V to 3.6 V)
V_{CCQ}	Power Supply	Power supply inputs for the inputs and outputs of the device.

Device Operation

CY14V101Q3 is a 1 Mbit nvSRAM memory with a nonvolatile element in each memory cell. All the reads and writes to nvSRAM happen to the SRAM which gives nvSRAM the unique capability to handle infinite writes to the memory. The data in SRAM is secured by a STORE sequence which transfers the data in parallel to the nonvolatile QuantumTrap cells. A small capacitor (V_{CAP}) is used to AutoStore the SRAM data in nonvolatile cells when power goes down providing power-down data security. The QuantumTrap nonvolatile elements built in the reliable SONOS technology make nvSRAM the ideal choice for secure data storage.

The 1 Mbit memory array is organized as 128 K words x 8 bits. The memory is accessed through a standard SPI interface that enables very high clock speeds up to 30 MHz with zero cycle delay read and write cycles. This device supports SPI modes 0 and 3 (CPOL, CPHA = 0, 0 and 1, 1) and operates as SPI slave. The device is enabled using the Chip Select (\overline{CS}) pin and accessed through Serial Input (SI), Serial Output (SO), and Serial Clock (SCK) pins.

This device provides the feature for hardware and software write protection through the WP pin and WRDI instruction respectively along with mechanisms for block write protection (1/4, 1/2, or full array) using BP0 and BP1 pins in the status register. Further, the HOLD pin can be used to suspend any serial communication without resetting the serial sequence.

CY14V101Q3 uses the standard SPI opcodes for memory access. In addition to the general SPI instructions for read and write, it provides four special instructions which enable access to four nvSRAM specific functions: STORE, RECALL, AutoStore Disable (ASDISB), and AutoStore Enable (ASENB).

The major benefit of serial (SPI) nvSRAM over serial EEPROMs is that all reads and writes to nvSRAM are performed at the speed of SPI bus with zero cycle delay. Therefore, no wait time is required after any of the memory accesses. The STORE and RECALL operations need finite time to complete and all memory accesses are inhibited during this time. While a STORE or RECALL operation is in progress, the busy status of the device is indicated by the Hardware STORE Busy (HSB) pin and also reflected on the RDY bit of the Status Register.

SRAM Write

All writes to nvSRAM are carried out on the SRAM and do not use up any endurance cycles of the nonvolatile memory. This enables the user to perform infinite write operations. A write cycle is performed through the WRITE instruction. The WRITE instruction is issued through the SI pin of the nvSRAM and

consists of the WRITE opcode, three bytes of address, and one byte of data. Write to nvSRAM is done at SPI bus speed with zero cycle delay.

The device allows burst mode writes to be performed through SPI. This enables write operations on consecutive addresses without issuing a new WRITE instruction. When the last address in memory is reached in burst mode, the address rolls over to 0x0000 and the device continues to write.

The SPI write cycle sequence is defined in the memory access section of SPI Protocol Description.

SRAM Read

A read cycle is performed at the SPI bus speed and the data is read out with zero cycle delay after the READ instruction is executed. The READ instruction is issued through the SI pin of the nvSRAM and consists of the READ opcode and 3 bytes of address. The data is read out on the SO pin.

This device allows burst mode reads to be performed through SPI. This enables reads on consecutive addresses without issuing a new READ instruction. When the last address in memory is reached in burst mode read, the address rolls over to 0x0000 and the device continues to read.

The SPI read cycle sequence is defined in the memory access section of SPI Protocol Description.

STORE Operation

STORE operation transfers the data from the SRAM to the nonvolatile QuantumTrap cells. The device stores data to the nonvolatile cells using one of the three STORE operations: AutoStore, activated on device power-down; Software STORE, activated by a STORE instruction; and Hardware STORE, activated by the HSB. During the STORE cycle, an erase of the previous nonvolatile data is first performed, followed by a program of the nonvolatile elements. After a STORE cycle is initiated, read/write to CY14V101Q3 is inhibited until the cycle is completed.

The HSB signal or the RDY bit in the Status register can be monitored by the system to detect if a STORE or Software RECALL cycle is in progress. The busy status of nvSRAM is indicated by HSB being pulled LOW or RDY bit being set to '1'. To avoid unnecessary nonvolatile STOREs, AutoStore and Hardware STORE operations are ignored unless at least one write operation has taken place since the most recent STORE or RECALL cycle. However, software initiated STORE cycles are performed regardless of whether a write operation has taken place.

AutoStore Operation

The AutoStore operation is a unique feature of nvSRAM which automatically stores the SRAM data to QuantumTrap during power-down. This STORE makes use of an external capacitor (V_{CAP}) and enables the device to safely STORE the data in the nonvolatile memory when power goes down.

During normal operation, the device draws current from V_{CC} to charge the capacitor connected to the V_{CAP} pin. When the voltage on the V_{CC} pin drops below V_{SWITCH} during power-down, the device inhibits all memory accesses to nvSRAM and automatically performs a conditional STORE operation using the charge from the V_{CAP} capacitor. The AutoStore operation is not initiated if no write cycle has been performed since the last RECALL.

Note If a capacitor is not connected to V_{CAP} pin, AutoStore must be disabled by issuing the AutoStore Disable instruction specified in [AutoStore Disable \(ASDISB\) instruction](#) on page 13. If AutoStore is enabled without a capacitor on the V_{CAP} pin, the device attempts an AutoStore operation without sufficient charge to complete the STORE. This corrupts the data stored in the nvSRAM and Status register. To resume normal functionality, the WRSR instruction must be issued to update the nonvolatile bits BP0, BP1 and WPEN in the Status Register.

Figure 2 shows the proper connection of the storage capacitor (V_{CAP}) for AutoStore operation. See [DC Electrical Characteristics](#) on page 15 for the size of the V_{CAP} .

Figure 2. AutoStore Mode

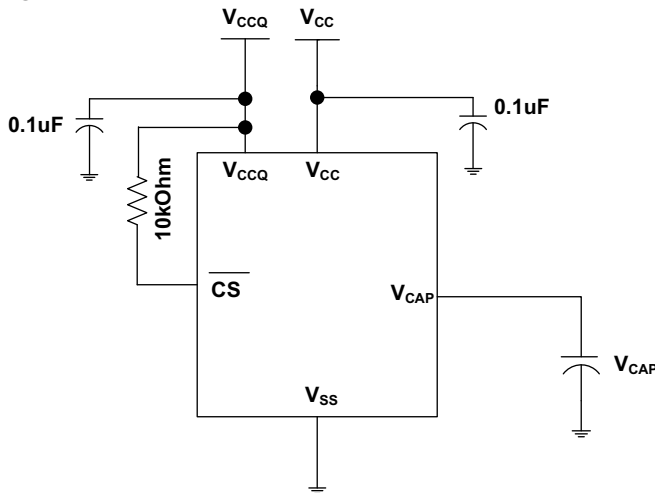

Software STORE Operation

Software STORE enables the user to trigger a STORE operation through a special SPI instruction. STORE operation is initiated by executing STORE instruction irrespective of whether a write has been performed since the last NV operation.

A STORE cycle takes t_{STORE} time to complete, during which all the memory accesses to nvSRAM are inhibited. The RDY bit of the Status register or the HSB pin may be polled to find the Ready or Busy status of the nvSRAM. After the t_{STORE} cycle time is completed, the SRAM is activated again for read and write operations.

Hardware STORE and HSB Pin Operation

The \overline{HSB} pin in CY14V101Q3 is used to control and acknowledge STORE operations. If no STORE or RECALL is in progress, this pin can be used to request a Hardware STORE cycle. When the \overline{HSB} pin is driven LOW, nvSRAM conditionally initiates a STORE operation after t_{DELAY} duration. An actual STORE cycle starts only if a write to the SRAM has been performed since the last STORE or RECALL cycle. Reads and writes to the memory are inhibited for t_{STORE} duration or as long as \overline{HSB} pin is LOW.

The \overline{HSB} pin also acts as an open drain driver (internal 100 kΩ weak pull-up resistor) that is internally driven LOW to indicate a busy condition when the STORE (initiated by any means) is in progress.

Note After each Hardware and Software STORE operation \overline{HSB} is driven HIGH for a short time (t_{HHHD}) with standard output high current and then remains HIGH by an internal 100 kΩ pull-up resistor.

Note For successful last data byte STORE, a hardware store should be initiated at least one clock cycle after the last data bit D0 is received.

Upon completion of the STORE operation, the nvSRAM memory access is inhibited for t_{LZHSB} time after \overline{HSB} pin returns HIGH. The \overline{HSB} pin must be left unconnected if not used.

RECALL Operation

A RECALL operation transfers the data stored in the nonvolatile QuantumTrap elements to the SRAM. A RECALL may be initiated in two ways: Hardware RECALL, initiated on power-up; and Software RECALL, initiated by a SPI RECALL instruction.

Internally, RECALL is a two-step procedure. First, the SRAM data is cleared. Next, the nonvolatile information is transferred into the SRAM cells. All memory accesses are inhibited while a RECALL cycle is in progress. The RECALL operation does not alter the data in the nonvolatile elements.

Hardware RECALL (Power-up)

During power-up, when V_{CC} crosses V_{SWITCH} , an automatic RECALL sequence is initiated which transfers the content of nonvolatile memory on to the SRAM. The data would previously have been stored on the nonvolatile memory through a STORE sequence.

A Power-up RECALL cycle takes t_{FA} time to complete and the memory access is disabled during this time. \overline{HSB} pin is used to detect the Ready status of the device.

Software RECALL

Software RECALL enables the user to initiate a RECALL operation to restore the content of nonvolatile memory on to the SRAM. A Software RECALL is issued by using the SPI instruction for RECALL.

A Software RECALL takes t_{RECALL} time to complete during which all memory accesses to nvSRAM are inhibited. The controller must provide sufficient delay for the RECALL operation to complete before issuing any memory access instructions.

Disabling and Enabling AutoStore

If the application does not require the AutoStore feature, it can be disabled by using the ASDISB instruction. If this is done, the nvSRAM does not perform a STORE operation at power-down.

AutoStore can be re-enabled by using the ASENB instruction. However, these operations are not nonvolatile and if the user need this setting to survive the power cycle, a STORE operation must be performed following AutoStore Disable or Enable operation.

Note CY14V101Q3 has AutoStore Enabled from the factory. If AutoStore is disabled and V_{CAP} is not required, then the V_{CAP} pin must be left open. V_{CAP} pin must never be connected to ground. Power-up RECALL operation cannot be disabled in any case.

Noise Considerations

See CY application note [AN1064](#).

Serial Peripheral Interface

SPI Overview

The SPI is a four-pin interface with Chip Select (\overline{CS}), Serial Input (SI), Serial Output (SO), and Serial Clock (SCK) pins. CY14V101Q3 provides serial access to nvSRAM through SPI interface. The SPI bus on this device can run at speeds up to 30 MHz.

The SPI is a synchronous serial interface which uses clock and data pins for memory access and supports multiple devices on the data bus. A device on SPI bus is activated using a \overline{CS} pin.

The relationship between chip select, clock, and data is dictated by the SPI mode. This device supports SPI modes 0 and 3. In both these modes, data is clocked into the nvSRAM on the rising edge of SCK starting from the first rising edge after \overline{CS} goes active.

The SPI protocol is controlled by opcodes. These opcodes specify the commands from the bus master to the slave device. After \overline{CS} is activated the first byte transferred from the bus master is the opcode. Following the opcode, any addresses and data are then transferred. The \overline{CS} must go inactive after an operation is complete and before a new opcode can be issued. The commonly used terms used in SPI protocol are as follows:

SPI Master

The SPI master device controls the operations on a SPI bus. A SPI bus may have only one master with one or more slave devices. All the slaves share the same SPI bus lines and the master may select any of the slave devices using the \overline{CS} pin. All the operations must be initiated by the master activating a slave device by pulling the \overline{CS} pin of the slave LOW. The master also generates the SCK and all the data transmission on SI and SO lines are synchronized with this clock.

SPI Slave

The SPI slave device is activated by the master through the chip select line. A slave device gets the SCK as an input from the SPI master and all the communication is synchronized with this clock. SPI slave never initiates a communication on the SPI bus and acts on the instruction from the master.

CY14V101Q3 operates as a SPI slave and may share the SPI bus with other SPI slave devices.

Chip Select (\overline{CS})

For selecting any slave device, the master needs to pull-down the corresponding \overline{CS} pin. Any instruction can be issued to a slave device only while the \overline{CS} pin is LOW. When the device is not selected, data through the SI pin is ignored and the serial output pin (SO) remains in a high-impedance state.

Note A new instruction must begin with the falling edge of \overline{CS} . Therefore, only one opcode can be issued for each active chip select cycle.

Serial Clock (SCK)

Serial clock is generated by the SPI master and the communication is synchronized with this clock after \overline{CS} goes LOW.

CY14V101Q3 enables SPI modes 0 and 3 for data communication. In both these modes, the inputs are latched by the slave device on the rising edge of SCK and outputs are issued on the falling edge. Therefore, the first rising edge of SCK signifies the arrival of the first bit (MSB) of SPI instruction on the SI pin. Further, all data inputs and outputs are synchronized with SCK.

Data Transmission - SI and SO

SPI data bus consists of two lines, SI and SO, for serial data communication. The SI is also referred to as Master Out Slave In (MOSI) and SO is referred to as Master In Slave Out (MISO). The master issues instructions to the slave through the SI pin, while the slave responds through the SO pin. Multiple slave devices may share the SI and SO lines as described earlier.

Most Significant Bit (MSB)

The SPI protocol requires that the first bit to be transmitted is the most significant bit (MSB). This is valid for both address and data transmission.

The 1 Mbit serial nvSRAM requires a 3-byte address for any read or write operation. However, since the actual address is only 17 bits, it implies that the first seven bits which are fed in are ignored by the device. Although these seven bits are 'don't care', Cypress recommends that these bits are treated as 0s to enable seamless transition to higher memory densities.

Serial Opcode

After the slave device is selected with \overline{CS} going LOW, the first byte received is treated as the opcode for the intended operation. CY14V101Q3 uses the standard opcodes for memory accesses. In addition to the memory accesses, it provides additional opcodes for the nvSRAM specific functions: STORE, RECALL, AutoStore Enable, and AutoStore Disable. See [Table 2](#) on page 8 for details.

Invalid Opcode

If an invalid opcode is received, the opcode is ignored and the device ignores any additional serial data on the SI pin till the next falling edge of \overline{CS} and the SO pin remains tristated.

Status Register

CY14V101Q3 has an 8-bit status register. The bits in the status register are used to configure the SPI bus. These bits are described in the [Table 4](#) on page 9.

Figure 3. System Configuration Using SPI nvSRAM

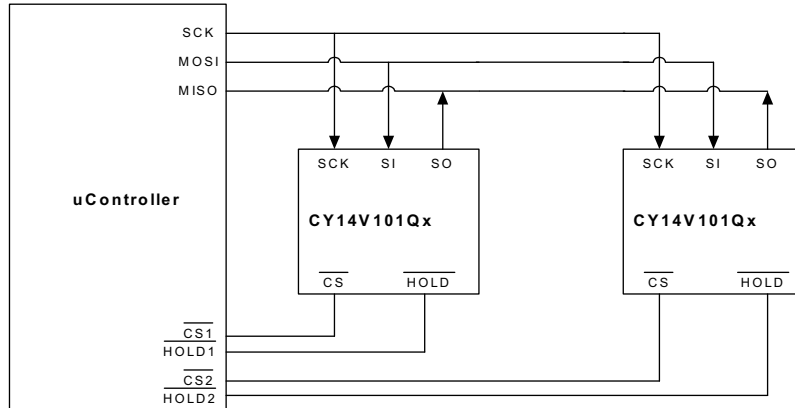

SPI Modes

CY14V101Q3 may be driven by a microcontroller with its SPI peripheral running in either of the following two modes:

- SPI Mode 0 (CPOL=0, CPHA=0)
- SPI Mode 3 (CPOL=1, CPHA=1)

For both these modes, the input data is latched-in on the rising edge of SCK starting from the first rising edge after CS goes active. If the clock starts from a HIGH state (in mode 3), the first rising edge, after the clock toggles, is considered. The output data is available on the falling edge of SCK.

The two SPI modes are shown in [Figure 4](#) and [Figure 5](#). The status of clock when the bus master is in standby mode and not transferring data is:

- SCK remains at 0 for Mode 0
- SCK remains at 1 for Mode 3

CPOL and CPHA bits must be set in the SPI controller for the either Mode 0 or Mode 3. The device detects the SPI mode from the status of SCK pin when the device is selected by bringing the CS pin LOW. If SCK pin is LOW when the device is selected, SPI Mode 0 is assumed and if SCK pin is HIGH, it works in SPI Mode 3.

Figure 4. SPI Mode 0

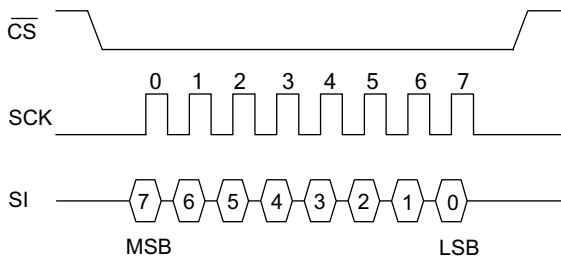
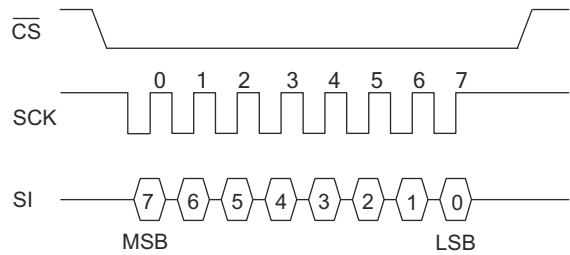

Figure 5. SPI Mode 3



SPI Operating Features

Power-up

Power-up is defined as the condition when the power supply is turned on and V_{CC} crosses V_{switch} voltage. During this time, the \overline{CS} must be allowed to follow the V_{CC} voltage. Therefore, \overline{CS} must be connected to V_{CC} through a suitable pull-up resistor. As a built-in safety feature, \overline{CS} is both edge sensitive and level sensitive. After power-up, the device is not selected until a falling edge is detected on \overline{CS} . This ensures that \overline{CS} is HIGH, before going LOW to start the first operation.

As described earlier, nvSRAM performs a Power-up RECALL operation after power-up and therefore, all memory accesses are disabled for t_{FA} duration after power-up. The HSB pin can be probed to check the ready or busy status of nvSRAM after power-up.

Power-on Reset

A power-on reset (POR) circuit is included to prevent inadvertent writes. At power-up, the device does not respond to any instruction until the V_{CC} reaches the POR threshold voltage (V_{SWITCH}). After V_{CC} transitions the POR threshold, the device is internally reset and performs a Power-Up RECALL operation. During Power-Up RECALL all device accesses are inhibited. The device is in the following state after POR:

- Deselected (after power-up, a falling edge is required on \overline{CS} before any instructions are started).
- Standby power mode
- Not in the HOLD condition
- Status register state:
 - Write Enable (WEN) bit is reset to 0.
 - WPEN, BP1, BP0 unchanged from previous STORE operation
 - Don't care bits 4-6 are reset to 0.

The WPEN, BP1, and BP0 bits of the Status Register are nonvolatile bits and remain unchanged from the previous STORE operation.

Before selecting and issuing instructions to the memory, a valid and stable V_{CC} voltage must be applied. This voltage must remain valid until the end of the instruction transmission.

Power-Down

At power-down (continuous decay of V_{CC}), when V_{CC} drops from the normal operating voltage and below the V_{SWITCH} threshold voltage, the device stops responding to any instruction sent to it. If a write cycle is in progress and the last data bit D0 has been received when the power goes down, it is allowed t_{DELAY} time to complete the write. After which all memory accesses are inhibited and a conditional AutoStore operation is performed (AutoStore is not performed if no writes have happened since last RECALL cycle). When $V_{CCQ} < V_{IODIS}$, I/Os are disabled (no STORE takes place). This protects against inadvertent writes during brown out conditions on V_{CCQ} supply.

However, to completely avoid the possibility of inadvertent writes during power-down, ensure that the device is deselected and is

in standby power mode, and the \overline{CS} follows the voltage applied on V_{CC} .

Active Power and Standby Power Modes

When \overline{CS} is LOW, the device is selected, and is in the active power mode. The device consumes I_{CC} current, as specified in DC Electrical Characteristics on page 15. When \overline{CS} is HIGH, the device is deselected and the device goes into the standby power mode if a STORE or RECALL cycle is not in progress. If a STORE or RECALL cycle is in progress, the device goes into the standby power mode after the STORE or RECALL cycle is completed. In the standby power mode, the current drawn by the device drops to I_{SB} .

SPI Functional Description

The CY14V101Q3 uses an 8-bit instruction register. Instructions and their operation codes are listed in Table 2. All instructions, addresses, and data are transferred with the MSB first and start with a HIGH to LOW \overline{CS} transition. There are, in all, 10 SPI instructions which provide access to most of the functions in nvSRAM. Further, the WP, HOLD, and HSB pins provide additional functionality driven through hardware.

Table 2. Instruction Set

Instruction Category	Instruction Name	Opcode	Operation
Status Register Control Instructions	WREN	0000 0110	Set write enable latch
	WRDI	0000 0100	Reset write enable latch
	RDSR	0000 0101	Read Status Register
	WRSR	0000 0001	Write Status Register
SRAM Read/Write Instructions	READ	0000 0011	Read data from memory array
	WRITE	0000 0010	Write data to memory array
Special NV Instructions	STORE	0011 1100	Software STORE
	RECALL	0110 0000	Software RECALL
	ASENB	0101 1001	AutoStore Enable
	ASDISB	0001 1001	AutoStore Disable
Reserved	- Reserved -	0001 1110	

The SPI instructions are divided based on their functionality in the following types:

- Status Register access: RDSR and WRSR instructions
- Write protection functions: WREN and WRDI instructions along with WP pin and WEN, BP0, and BP1 bits
- SRAM memory access: READ and WRITE instructions
- nvSRAM special instructions: STORE, RECALL, ASENB, and ASDISB

Status Register

The status register bits are listed in Table 4. The status register consists of a Ready bit (\overline{RDY}) and data protection bits BP1, BP0, WEN, and WPEN. The RDY bit can be polled to check the Ready or Busy status while a nvSRAM STORE or Software RECALL cycle is in progress. The status register can be modified by WRSR instruction and read by RDSR instruction. However, only the WPEN, BP1, and BP0 bits of the Status Register can be modified by using WRSR instruction. The WRSR instruction has no effect on WEN and RDY bits. The default value shipped from the factory for WEN, BP0, BP1, bits 4-6 and WPEN bits is '0'.

Table 3. Status Register Format

Bit 7	Bit 6	Bit 5	Bit 4	Bit 3	Bit 2	Bit 1	Bit 0
WPEN (0)	X (0)	X (0)	X (0)	BP1 (0)	BP0 (0)	WEN (0)	\overline{RDY}

Table 4. Status Register Bit Definition

Bit	Definition	Description
Bit 0 (RDY)	Ready	Read only bit indicates the ready status of device to perform a memory access. This bit is set to '1' by the device while a STORE or Software RECALL cycle is in progress.
Bit 1 (WEN)	Write Enable	WEN indicates if the device is Write Enabled. This bit defaults to '0' (disabled) on power-up. WEN = '1' --> Write Enabled WEN = '0' --> Write Disabled
Bit 2 (BP0)	Block protect bit '0'	Used for block protection. For details see Table 5 on page 10.
Bit 3 (BP1)	Block protect bit '1'	Used for block protection. For details see Table 5 on page 10.
Bits 4-6	Don't care	Bits are writable and volatile. On power-up, bits are written with '0'.
Bit 7 (WPEN)	Write protect enable bit	Used for enabling the function of Write Protect Pin (WP). For details see Table 6 on page 11.

Read Status Register (RDSR) Instruction

The Read Status Register instruction provides access to the status register. This instruction is used to probe the Write Enable Status of the device or the Ready status of the device. \overline{RDY} bit is set by the device to '1' whenever a STORE or Software RECALL cycle is in progress. The block protection and WPEN bits indicate the extent of protection employed.

This instruction is issued after the falling edge of \overline{CS} using the opcode for RDSR.

Write Status Register (WRSR) Instruction

The WRSR instruction enables the user to write to the Status register. However, this instruction cannot be used to modify bit 0 and bit 1 (\overline{RDY} and WEN). The BP0 and BP1 bits can be used

to select one of four levels of block protection. Further, WPEN bit must be set to '1' to enable the use of write protect (WP) pin.

WRSR instruction is a write instruction and needs writes to be enabled (WEN bit set to '1') using the WREN instruction before it is issued. The instruction is issued after the falling edge of CS using the opcode for WRSR followed by 8 bits of data to be stored in the Status Register. Since only bits 2, 3, and 7 can be modified by WRSR instruction; therefore, it is recommended to leave the bits 4-6 as '0' while writing to the Status Register

Note In CY14V101Q3, the values written to Status Register are saved to nonvolatile memory only after a STORE operation. If AutoStore is disabled, any modifications to the Status Register must be secured by performing a Software STORE operation.

Figure 6. Read Status Register (RDSR) Instruction Timing

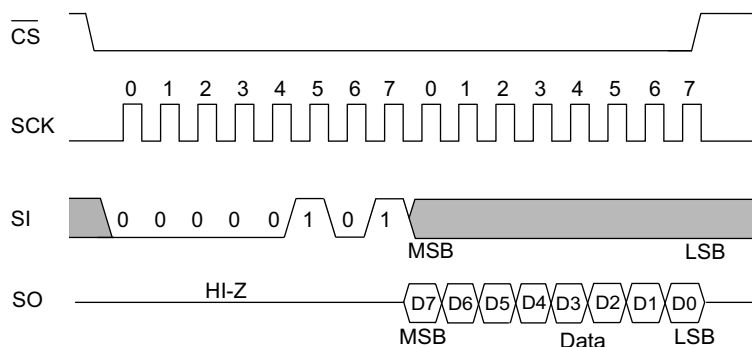
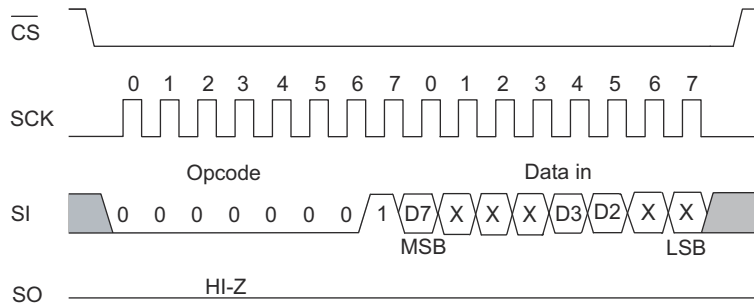

Figure 7. Write Status Register (WRSR) Instruction Timing



Write Protection and Block Protection

CY14V101Q3 provides features for both software and hardware write protection using WRDI instruction and WP. Additionally, this device also provides block protection mechanism through BP0 and BP1 pins of the Status Register.

The write enable and disable status of the device is indicated by WEN bit of the status register. The write instructions (WRSR and WRITE) and nvSRAM special instruction (STORE, RECALL, ASENb, and ASDISb) need the write to be enabled (WEN bit = 1) before they can be issued.

Write Enable (WREN) Instruction

On power-up, the device is always in the write disable state. The following WRITE, WRSR, or nvSRAM special instruction must therefore be preceded by a Write Enable instruction. If the device is not write enabled (WEN = '0'), it ignores the write instructions and returns to the standby state when CS is brought HIGH. A new CS falling edge is required to re-initiate serial communication. The instruction is issued following the falling edge of CS. When this instruction is used, the WEN bit of status register is set to '1'. WEN bit defaults to '0' on power-up.

Note After completion of a write instruction (WRSR or WRITE) or nvSRAM special instruction (STORE, RECALL, ASENb, and ASDISb) instruction, WEN bit is cleared to '0'. This is done to provide protection from any inadvertent writes. Therefore, WREN instruction must be used before a new write instruction is issued.

Figure 8. WREN Instruction

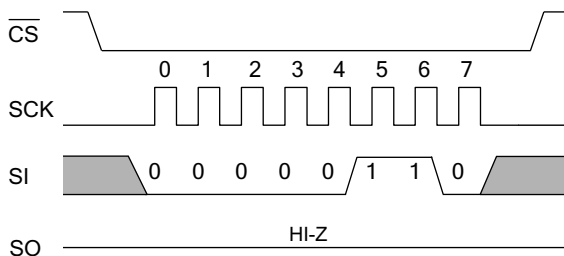

Write Disable (WRDI) Instruction

Write Disable instruction disables the write by clearing the WEN bit to '0' in order to protect the device against inadvertent writes. This instruction is issued following the falling edge of CS followed by opcode for WRDI instruction. The WEN bit is cleared on the rising edge of CS following a WRDI instruction.

Figure 9. WRDI Instruction

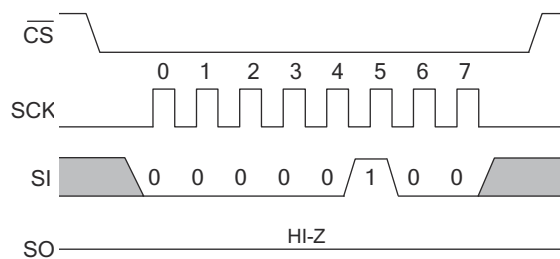

Block Protection

Block protection is provided using the BP0 and BP1 pins of the Status register. These bits can be set using WRSR instruction and probed using the RDSR instruction. The nvSRAM is divided into four array segments. One-quarter, one-half, or all of the memory segments can be protected. Any data within the protected segment is read only. Table 5 shows the function of block protect bits.

Table 5. Block Write Protect Bits

Level	Status Register Bits		Array Addresses Protected
	BP1	BP0	
0	0	0	None
1 (1/4)	0	1	0x18000-0x1FFFF
2 (1/2)	1	0	0x10000-0x1FFFF
3 (All)	1	1	0x00000-0x1FFFF

Write Protect (\overline{WP}) Pin

The write protect pin (\overline{WP}) is used to provide hardware write protection. \overline{WP} pin enables all normal read and write operations when held HIGH. When the \overline{WP} pin is brought LOW and WPEN bit is '1', all write operations to the status register are inhibited. The hardware write protection function is blocked when the WPEN bit is '0'. This enables the user to install the device in a system with the \overline{WP} pin tied to ground, and still write to the status register.

\overline{WP} pin can be used along with WPEN and block protect bits (BP1 and BP0) of the status register to inhibit writes to memory. When \overline{WP} pin is LOW and WPEN is set to '1', any modifications to status register are disabled. Therefore, the memory is protected by setting the BP0 and BP1 bits and the \overline{WP} pin inhibits any modification of the status register bits, providing hardware write protection.

Note \overline{WP} going LOW when \overline{CS} is still LOW has no effect on any of the ongoing write operations to the status register.

Table 6 summarizes all the protection features of this device

Table 6. Write Protection Operation

WPEN	\overline{WP}	WEN	Protected Blocks	Unprotected Blocks	Status Register
X	X	0	Protected	Protected	Protected
0	X	1	Protected	Writable	Writable
1	LOW	1	Protected	Writable	Protected
1	HIGH	1	Protected	Writable	Writable

Memory Access

All memory accesses are done using the READ and WRITE instructions. These instructions cannot be used while a STORE or RECALL cycle is in progress. A STORE cycle in progress is indicated by the RDY bit of the status register and the HSB pin.

Read Sequence (READ) instruction

The read operations on this device are performed by giving the instruction on SI and reading the output on SO pin. The following sequence needs to be followed for a read operation: After the \overline{CS} line is pulled LOW to select a device, the read opcode is transmitted through the SI line followed by three bytes of address. The Most Significant address byte contains A16 in bit 0

and other bits as 'don't cares'. Address bits A15 to A0 are sent in the following two address bytes. After the last address bit is transmitted on the SI pin, the data (D7-D0) at the specific address is shifted out on the SO line on the falling edge of SCK starting with D7. Any other data on SI line after the last address bit is ignored.

CY14V101Q3 allows reads to be performed in bursts through SPI which can be used to read consecutive addresses without issuing a new READ instruction. If only one byte is to be read, the \overline{CS} line must be driven HIGH after one byte of data comes out. However, the read sequence may be continued by holding the \overline{CS} line LOW and the address is automatically incremented and data continues to shift out on SO pin. When the last data memory address (0x1FFFF) is reached, the address rolls over to 0x0000 and the device continues to read.

Write Sequence (WRITE) instruction

The write operations on this device are performed through the SI pin. To perform a write operation, if the device is write disabled, then the device must first be write enabled through the WREN instruction. When the writes are enabled (WEN = '1'), WRITE instruction is issued after the falling edge of \overline{CS} . A WRITE instruction constitutes transmitting the WRITE opcode on SI line followed by 3 bytes of address and the data (D7-D0) which is to be written. The Most Significant address byte contains A16 in bit 0 with other bits being 'don't cares'. Address bits A15 to A0 are sent in the following two address bytes.

CY14V101Q3 enables writes to be performed in bursts through SPI which can be used to write consecutive addresses without issuing a new WRITE instruction. If only one byte is to be written, the \overline{CS} line must be driven HIGH after the D0 (LSB of data) is transmitted. However, if more bytes are to be written, \overline{CS} line must be held LOW and address is incremented automatically. The following bytes on the SI line are treated as data bytes and written in the successive addresses. When the last data memory address (0x1FFFF) is reached, the address rolls over to 0x0000 and the device continues to write. The WEN bit is reset to '0' on completion of a WRITE sequence.

Note When a burst write reaches a protected block address, it continues the address increment into the protected space but does not write any data to the protected memory. If the address roll over takes the burst write to unprotected space, it resumes writes. The same operation is true if a burst write is initiated within a write protected block.

Figure 10. Read Instruction Timing

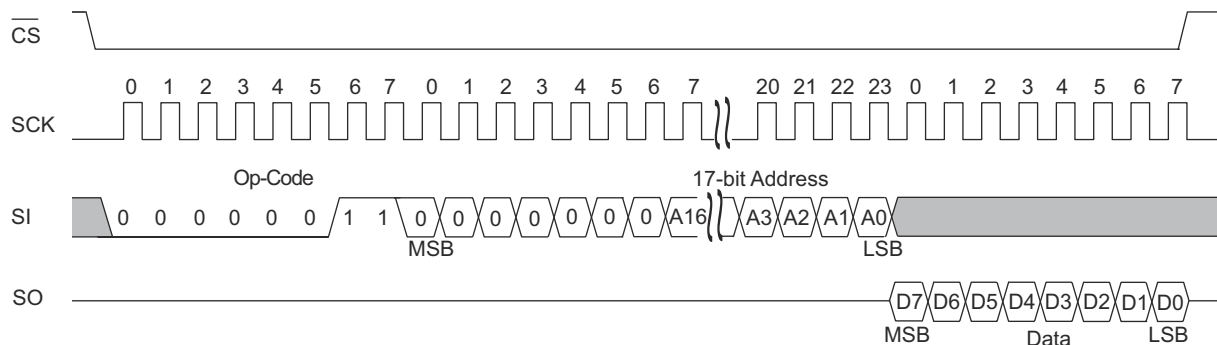

Figure 11. Burst Mode Read Instruction Timing

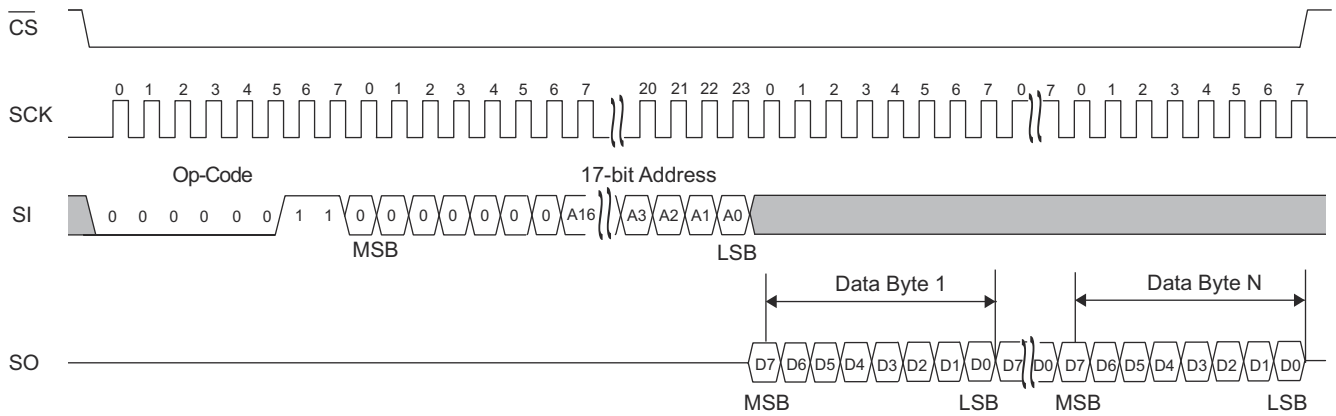

Figure 12. Write Instruction Timing

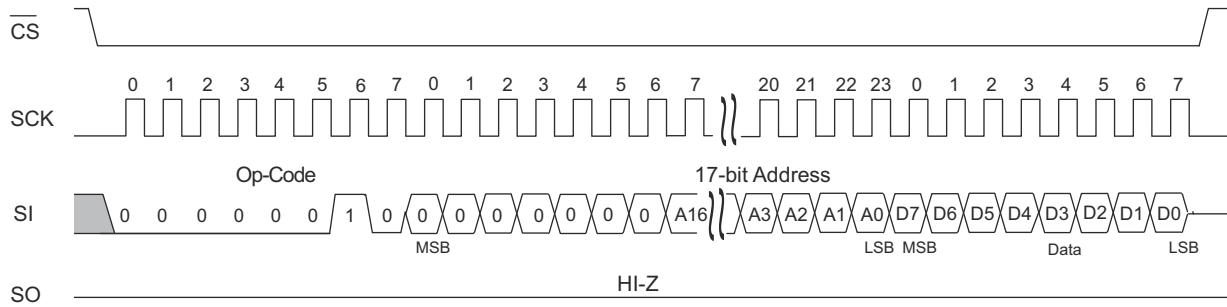
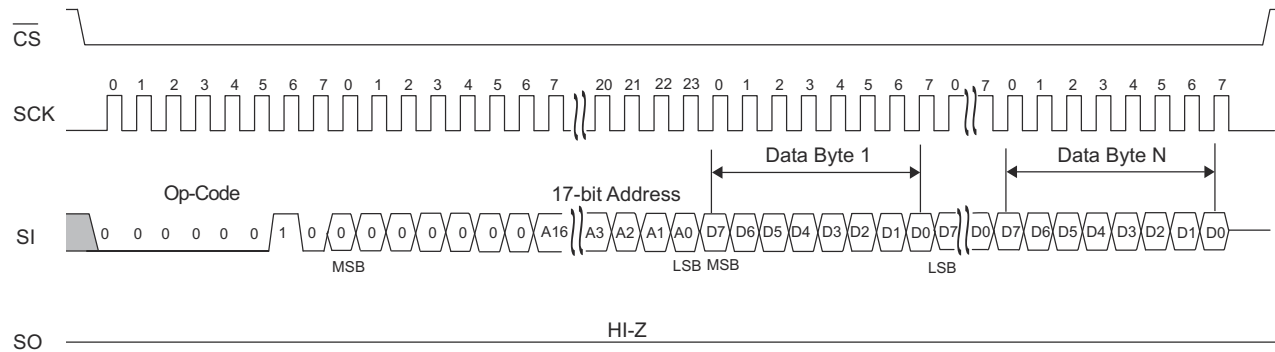

Figure 13. Burst Mode Write Instruction Timing



nvSRAM Special Instructions

CY14V101Q3 provides four special instructions which enables access to the nvSRAM specific functions: STORE, RECALL, ASDISB, and ASENB. Table 7 lists these instructions.

Table 7. nvSRAM Special Instructions

Function Name	Opcode	Operation
STORE	0011 1100	Software STORE
RECALL	0110 0000	Software RECALL
ASENB	0101 1001	AutoStore Enable
ASDISB	0001 1001	AutoStore Disable

Software STORE (STORE) instruction

When a STORE instruction is executed, nvSRAM performs a Software STORE operation. The STORE operation is performed irrespective of whether a write has taken place since the last STORE or RECALL operation.

To issue this instruction, the device must be write enabled (WEN bit = '1'). The instruction is performed by transmitting the STORE opcode on the SI pin following the falling edge of CS. The WEN bit is cleared on the positive edge of CS following the STORE instruction.

Figure 14. Software STORE Operation

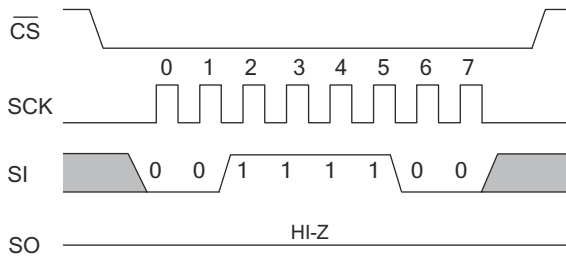

Software RECALL (RECALL) instruction

When a RECALL instruction is executed, nvSRAM performs a Software RECALL operation. To issue this instruction, the device must be write enabled (WEN = '1').

The instruction is performed by transmitting the RECALL opcode on the SI pin following the falling edge of CS. The WEN bit is cleared on the positive edge of CS following the RECALL instruction.

Figure 15. Software RECALL Operation

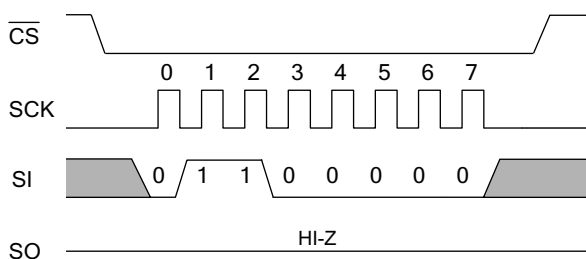

AutoStore Enable (ASENB) instruction

The AutoStore Enable instruction enables the AutoStore on CY14V101Q3. This setting is not nonvolatile and needs to be followed by a STORE sequence if this is desired to survive the power cycle.

To issue this instruction, the device must be write enabled (WEN = '1'). The instruction is performed by transmitting the ASENB opcode on the SI pin following the falling edge of CS. The WEN bit is cleared on the positive edge of CS following the ASENB instruction.

Note If ASDISB and ASENB instructions are executed in CY14V101Q3, the device is busy for the duration of software sequence processing time (t_{SS}).

Figure 16. AutoStore Enable Operation

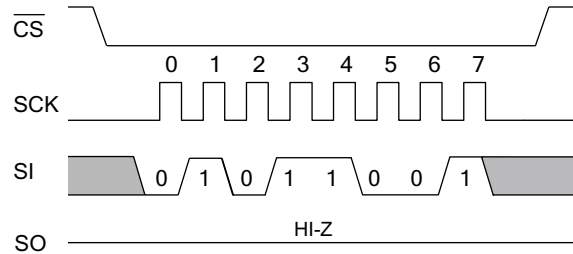

AutoStore Disable (ASDISB) instruction

AutoStore is enabled by default in CY14V101Q3. The ASDISB instruction disables the AutoStore. This setting is not nonvolatile and needs to be followed by a STORE sequence if this is desired to survive the power cycle.

To issue this instruction, the device must be write enabled (WEN = '1'). The instruction is performed by transmitting the ASDISB opcode on the SI pin following the falling edge of CS. The WEN bit is cleared on the positive edge of CS following the ASDISB instruction.

Figure 17. AutoStore Disable Operation

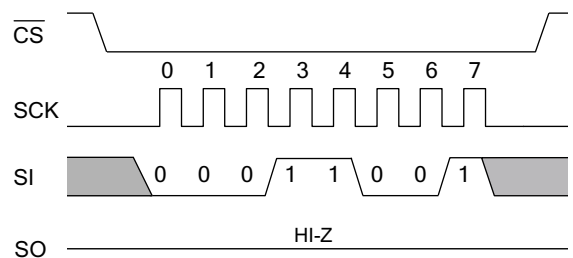

HOLD Pin Operation

The HOLD pin is used to pause the serial communication. When the device is selected and a serial sequence is underway, HOLD is used to pause the serial communication with the master device without resetting the ongoing serial sequence. To pause, the HOLD pin must be brought LOW when the SCK pin is LOW. CS pin must remain LOW along with HOLD pin to pause serial communication. While the device serial communication is paused, inputs to the SI pin are ignored and the SO pin is in the high impedance state. To resume serial communication, the HOLD pin must be brought HIGH when the SCK pin is LOW (SCK may toggle during HOLD).

Figure 18. HOLD Operation

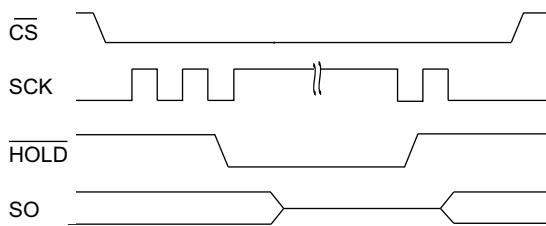

Best Practices

nvSRAM products have been used effectively for over 27 years. While ease-of-use is one of the product’s main system values, experience gained working with hundreds of applications has resulted in the following suggestions as best practices:

- The nonvolatile cells in this nvSRAM product are delivered from Cypress with 0x00 written in all cells. Incoming inspection routines at customer or contract manufacturer’s sites sometimes reprogram these values. Final NV patterns are typically repeating patterns of AA, 55, 00, FF, A5, or 5A. End product’s firmware should not assume an NV array is in a set programmed state. Routines that check memory content values to determine first time system configuration, cold or warm boot status, and so on should always program a unique NV pattern (that is, complex 4-byte pattern of 46 E6 49 53 hex or more random bytes) as part of the final system manufacturing test to ensure these system routines work consistently.
- Power-up boot firmware routines should rewrite the nvSRAM into the desired state (for example, AutoStore Enabled). While the nvSRAM is shipped in a preset state, best practice is to again rewrite the nvSRAM into the desired state as a safeguard against events that might flip the bit inadvertently such as program bugs and incoming inspection routines.
- The V_{CAP} value specified in this data sheet includes a minimum and a maximum value size. Best practice is to meet this requirement and not exceed the maximum V_{CAP} value because the nvSRAM internal algorithm calculates V_{CAP} charge and discharge time based on this maximum V_{CAP} value. Customers that want to use a larger V_{CAP} value to make sure there is extra STORE charge and STORE time should discuss their V_{CAP} size selection with Cypress to understand any impact on the V_{CAP} voltage level at the end of a t_{RECALL} period.

Maximum Ratings

Exceeding maximum ratings may shorten the useful life of the device. These user guidelines are not tested.

Storage temperature -65 °C to +150 °C

Maximum accumulated storage time

At 150 °C ambient temperature..... 1000 h

At 85 °C ambient temperature..... 20 Years

Ambient temperature with

power applied -55 °C to +150 °C

Supply voltage on V_{CC} relative to V_{SS}-0.5 V to +4.1 V

Supply voltage on V_{CCQ} relative to V_{SS} -0.5 V to +2.45 V

DC voltage applied to outputs

in High-Z state-0.5 V to $V_{CCQ} + 0.5$ V

Input voltage-0.5 V to $V_{CCQ} + 0.5$ V

Transient voltage (<20 ns) on

any pin to ground potential-2.0 V to $V_{CCQ} + 2.0$ V

Package power dissipation

capability ($T_A = 25$ °C) 1.0 W

Surface mount lead soldering

temperature (3 Seconds)..... +260 °C

DC output current (1 output at a time, 1s duration)..... 15 mA

Static discharge voltage..... > 2001 V
(per MIL-STD-883, Method 3015)

Latch up current..... > 140 mA

Operating Range

Range	Ambient Temperature	V_{CC}	V_{CCQ}
Industrial	-40 °C to +85 °C	3.0 V to 3.6 V	1.65 V to 1.95 V

DC Electrical Characteristics

Over the [Operating Range](#)

Parameter	Description	Test Conditions	Min	Typ ^[1]	Max	Unit
V_{CC}	Power supply voltage		3.0	3.3	3.6	V
V_{CCQ}			1.65	1.8	1.95	V
I_{CC1}	Average V_{CC} current	At $f_{SCK} = 30$ MHz. Values obtained without output loads ($I_{OUT} = 0$ mA)	-	-	10	mA
I_{CCQ1}	Average V_{CCQ} current		-	-	3	mA
I_{CC2}	Average V_{CC} current during STORE	All inputs don't care, $V_{CC} = \text{Max}$. Average current for duration t_{STORE}	-	-	10	mA
I_{CC4}	Average V_{CAP} current during AutoStore cycle	All inputs don't care. Average current for duration t_{STORE}	-	-	5	mA
I_{SB}	V_{CC} standby current	$CS \geq (V_{CCQ} - 0.2 \text{ V})$. $V_{IN} \leq 0.2 \text{ V}$ or $\geq (V_{CCQ} - 0.2 \text{ V})$. Standby current level after nonvolatile cycle is complete. Inputs are static. $f = 0$ MHz.	-	-	5	mA
I_{IX} ^[2]	Input leakage current (except HSB)	$V_{CCQ} = \text{Max}$, $V_{SS} \leq V_{IN} \leq V_{CCQ}$	-1	-	+1	μA
	Input leakage current (for HSB)	$V_{CCQ} = \text{Max}$, $V_{SS} \leq V_{IN} \leq V_{CCQ}$	-100	-	+1	μA
I_{OZ}	Off state output leakage current	$V_{CCQ} = \text{Max}$, $V_{SS} \leq V_{OUT} \leq V_{CCQ}$	-1	-	+1	μA
V_{IH}	Input HIGH voltage		$0.7V_{CCQ}$	-	$V_{CCQ} + 0.3$	V
V_{IL}	Input LOW voltage		-0.3	-	$0.3 V_{CCQ}$	V
V_{OH}	Output HIGH voltage	$I_{OUT} = -1$ mA	$V_{CCQ} - 0.45$	-	-	V
V_{OL}	Output LOW voltage	$I_{OUT} = 2$ mA	-	-	0.45	V
V_{CAP} ^[3]	Storage capacitor	Between V_{CAP} pin and V_{SS} . 5 V rated	61	68	180	μF

Notes

- Typical values are at 25 °C. $V_{CC} = V_{CC}(\text{Typ})$ and $V_{CCQ} = V_{CCQ}(\text{Typ})$. Not 100% tested.
- The HSB pin has $I_{OUT} = -4$ μA for V_{OH} of 1.07V when both active HIGH and LOW drivers are disabled. When they are enabled standard V_{OH} and V_{OL} are valid. This parameter is characterized but not tested.
- Min V_{CAP} value guarantees that there is a sufficient charge available to complete a successful AutoStore operation. Max V_{CAP} value guarantees that the capacitor on V_{CAP} is charged to a minimum voltage during a Power-Up RECALL cycle so that an immediate power-down cycle can complete a successful AutoStore. Therefore it is always recommended to use a capacitor within the specified min and max limits. See application note [AN43593](#) for more details on V_{CAP} options.

Data Retention and Endurance

Over the [Operating Range](#)

Parameter	Description	Min	Unit
DATA _R	Data retention	20	Years
NV _C	Nonvolatile STORE operations	1,000	K

Capacitance

Parameter ^[4]	Description	Test Conditions	Max	Unit
C _{IN}	Input capacitance	T _A = 25 °C, f = 1 MHz, V _{CC} = V _{CC} (Typ), V _{CCQ} = V _{CCQ} (Typ)	6	pF
C _{OUT}	Output pin capacitance		8	pF

Thermal Resistance

Parameter ^[4]	Description	Test Conditions	16-SOIC	Unit
θ _{JA}	Thermal resistance (junction to ambient)	Test conditions follow standard test methods and procedures for measuring thermal impedance, per EIA / JESD51.	55.17	°C/W
θ _{JC}	Thermal resistance (junction to case)		2.64	°C/W

Figure 19. AC Test Loads and Waveforms

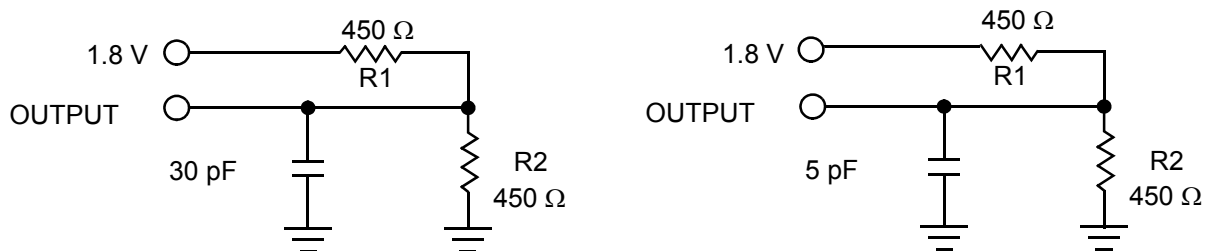

AC Test Conditions

Input pulse levels.....0 V to 1.8 V
 Input rise and fall times (10% - 90%)..... ≤1.8 ns
 Input and output timing reference levels..... 0.9 V

Note

4. These parameters are guaranteed by design and are not tested.

AC Switching Characteristics

 Over the [Operating Range](#)^[5]

Cypress Parameter	Alt. Parameter	Description	30 MHz		Unit
			Min	Max	
f_{SCK}	f_{SCK}	Clock frequency, SCK	–	30	MHz
t_{CL}	t_{WL}	Clock pulse width LOW	15	–	ns
t_{CH}	t_{WH}	Clock pulse width HIGH	15	–	ns
t_{CS}	t_{CE}	CS HIGH time	25	–	ns
t_{CSS}	t_{CES}	CS setup time	13	–	ns
t_{CSH}	t_{CEH}	CS hold time	13	–	ns
t_{SD}	t_{SU}	Data in setup time	7	–	ns
t_{HD}	t_H	Data in hold time	7	–	ns
t_{HH}	t_{HD}	HOLD hold time	7	–	ns
t_{SH}	t_{CD}	HOLD setup time	7	–	ns
t_{CO}	t_V	Output valid	–	12	ns
$t_{HHZ}^{[6]}$	t_{HZ}	HOLD to output High Z	–	15	ns
$t_{HLZ}^{[6]}$	t_{LZ}	HOLD to output Low Z	–	15	ns
t_{OH}	t_{HO}	Output hold time	0	–	ns
t_{HZCS}	t_{DIS}	Output disable time	–	25	ns

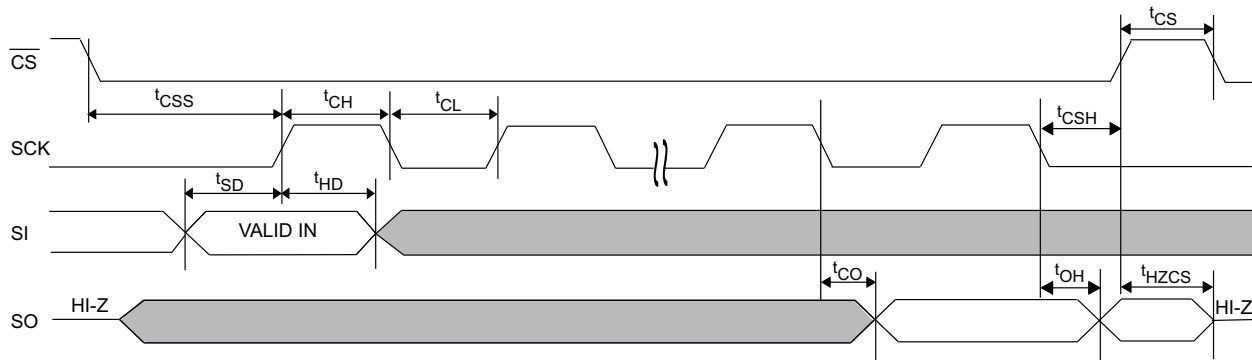
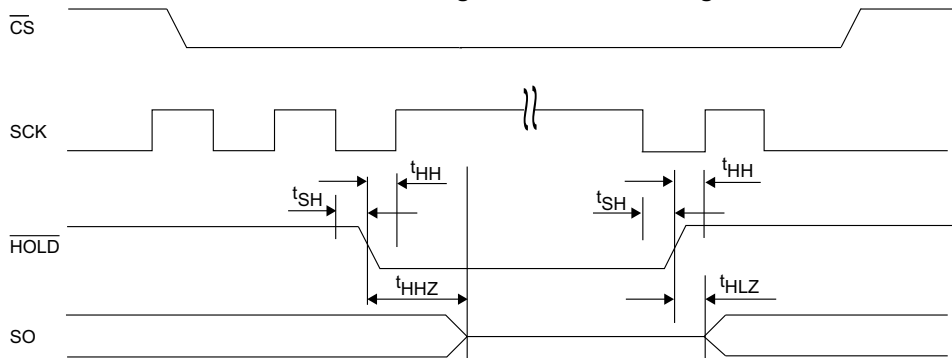
Figure 20. Synchronous Data Timing (Mode 0)

Figure 21. HOLD Timing

Note

5. Test conditions assume signal transition time of 1.8 ns or less, timing reference levels of $V_{CC}/2$, input pulse levels of 0 to V_{CC} (typ), and output loading of the specified I_{OL}/I_{OH} and load capacitance shown in [Figure 19](#).
6. These parameters are guaranteed by design and are not tested.

AutoStore or Power-Up RECALL

Over the [Operating Range](#)

Parameter	Description	CY14V101Q3		Unit
		Min	Max	
$t_{FA}^{[7]}$	Power-up RECALL duration	–	20	ms
$t_{STORE}^{[8]}$	STORE cycle duration	–	8	ms
$t_{DELAY}^{[9]}$	Time allowed to complete SRAM write cycle	–	25	ns
V_{SWITCH}	Low voltage trigger level	–	2.90	V
$V_{IODIS}^{[10]}$	I/O Disable Voltage on V_{CCQ}	–	1.50	V
$t_{VCCRRISE}^{[11]}$	V_{CC} rise time	150	–	μ s
$V_{HDIS}^{[11]}$	HSB output disable voltage	–	1.9	V
$t_{LZHSB}^{[11]}$	HSB high to nvSRAM active time	–	5	μ s
$t_{HHHD}^{[11]}$	HSB high active time	–	500	ns

Switching Waveforms

Figure 22. AutoStore or Power-up RECALL^[12]

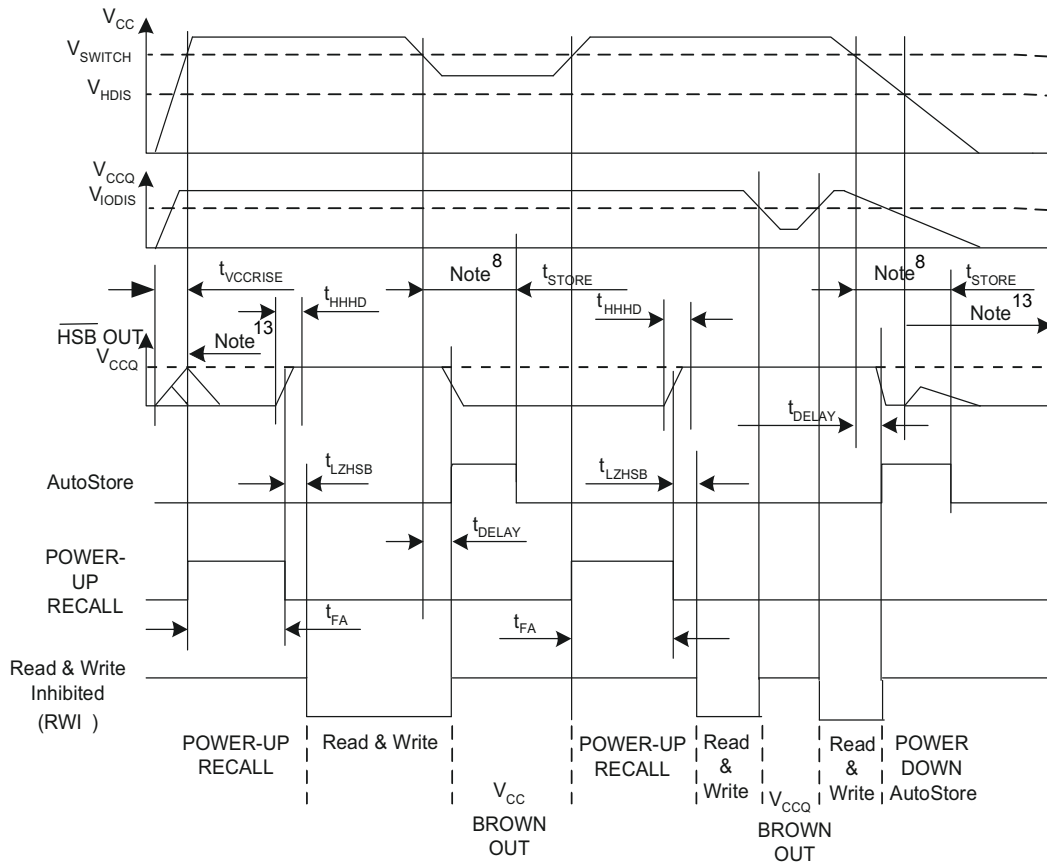

Notes

7. t_{FA} starts from the time V_{CC} rises above V_{SWITCH} .
8. If an SRAM write has not taken place since the last nonvolatile cycle, AutoStore or Hardware STORE is not initiated
9. On a Hardware STORE, Software STORE / RECALL, AutoStore Enable / Disable and AutoStore initiation, SRAM operation continues to be enabled for time t_{DELAY} .
10. HSB is not defined below V_{IODIS} voltage.
11. These parameters are guaranteed by design and are not tested.
12. Read and Write cycles are ignored during STORE, RECALL, and while V_{CC} is below V_{SWITCH} .
13. During power up and power down, HSB glitches when HSB pin is pulled up through an external resistor

Software Controlled STORE and RECALL Cycles

Over the [Operating Range](#)

Parameter	Description	CY14V101Q3		Unit
		Min	Max	
t_{RECALL}	RECALL duration	–	200	μs
t_{SS} [14, 15]	Soft sequence processing time	–	100	μs

Figure 23. Software STORE Cycle^[15]

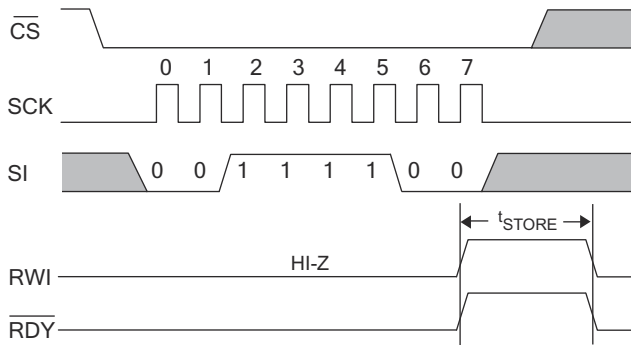

Figure 24. Software RECALL Cycle^[15]

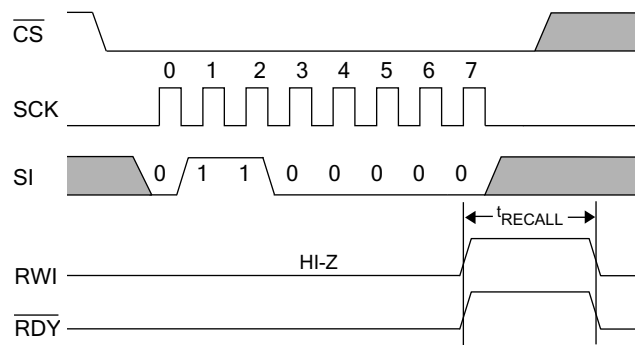

Figure 25. AutoStore Enable Cycle

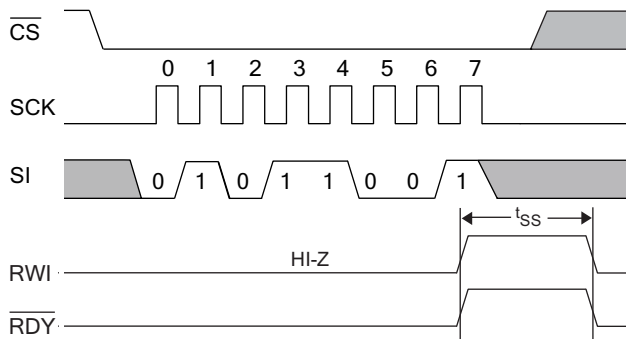
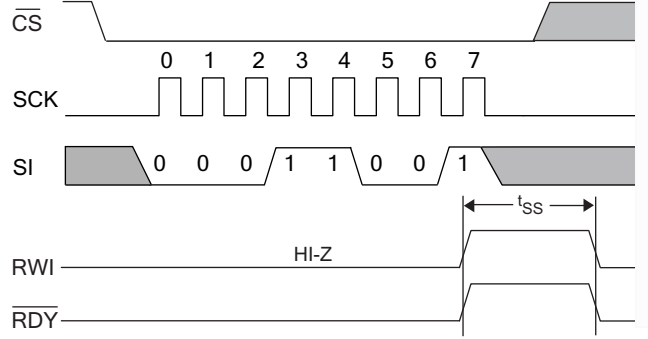

Figure 26. AutoStore Disable Cycle



Notes

- 14. This is the amount of time it takes to take action on a soft sequence command. Vcc power must remain HIGH to effectively register command.
- 15. Commands such as STORE and RECALL lock out I/O until operation is complete which further increases this time. See the specific command.

Hardware STORE Cycle

Over the [Operating Range](#)

Parameter	Description	CY14V101Q3		Unit
		Min	Max	
t_{PHSB}	Hardware STORE pulse width	15	–	ns

Figure 27. Hardware STORE Cycle^[16]

Write Latch set

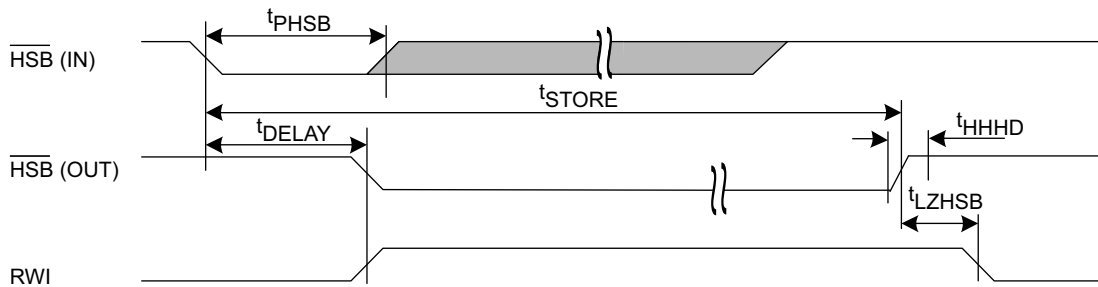

Write Latch not set

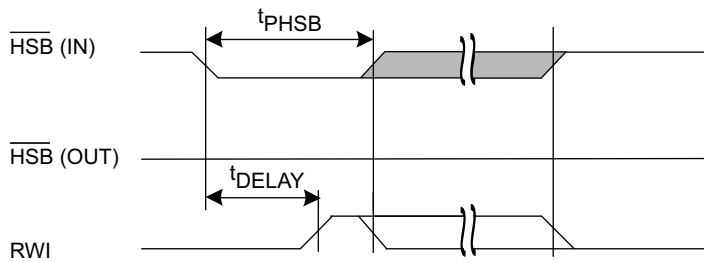

HSB pin is driven HIGH to V_{CC} only by Internal 100 K Ω resistor, HSB driver is disabled
SRAM is disabled as long as HSB (IN) is driven LOW.

Note

16. If an SRAM write has not taken place since the last nonvolatile cycle, no AutoStore or Hardware STORE takes place.

Ordering Information

Ordering Code	Package Diagram	Package Type	Operating Range
CY14V101Q3-SFXI	51-85022	16-pin SOIC	Industrial

All the above parts are Pb-free.

Ordering Code Definition

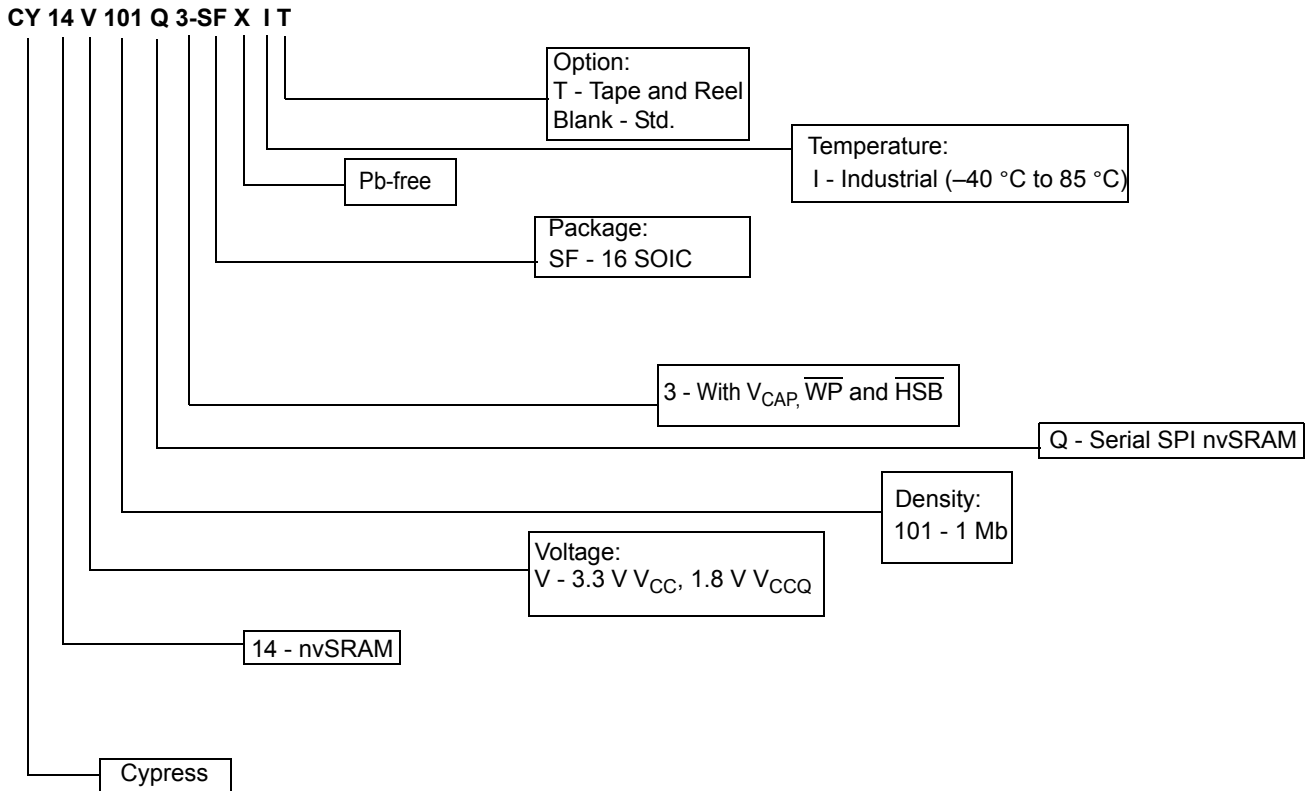

Package Diagrams

Figure 28. 16-pin (300-mil) SOIC (51-85022)

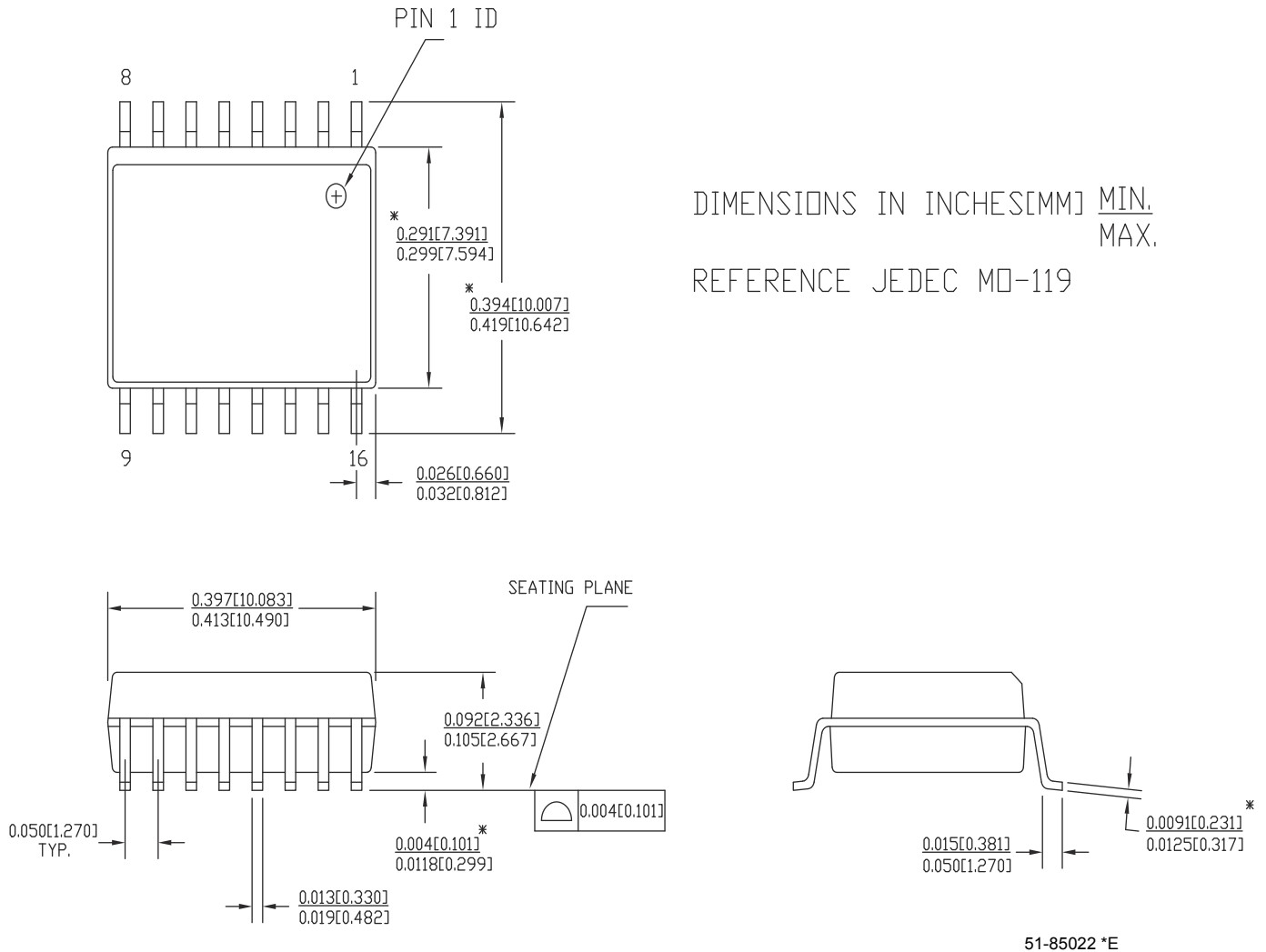

Acronyms

Acronym	Description
CPHA	Clock phase
CPOL	Clock polarity
DFN	Dual flat no-lead
EEPROM	Electrically erasable programmable read-only memory
EIA	Electronic Industries Alliance
I/O	Input/output
nvSRAM	nonvolatile static random access memory
RoHS	Restriction of hazardous substances
SOIC	Small outline integrated circuit
SONOS	Silicon-oxide-nitride-oxide-silicon
SPI	Serial peripheral interface

Document Conventions

Units of Measure

Symbol	Unit of Measure
°C	degrees Celsius
Hz	Hertz
kbit	1024 bits
kHz	kilohertz
KΩ	kilohms
μA	microamperes
mA	milliamperes
μF	microfarads
MHz	megahertz
μs	microseconds
ms	milliseconds
ns	nanoseconds
pF	picofarads
V	volts
Ω	ohms
W	watts

Document History Page

Document Title: CY14V101Q3 1 MBit (128 K × 8) Serial SPI nvSRAM				
Document Number: 001-67191				
Revision	ECN	Orig. of Change	Submission Date	Description of Change
**	3186112	GVCH	03/02/2011	New Datasheet
*A	3320849	GVCH	07/19/2011	Added footnote 3 and 5.
*B	3378700	GVCH	09/21/2011	Changed t _{CO} parameter spec from 9 ns to 12 ns
*C	3437820	GVCH	11/14/2011	Datasheet status changed from “Advance to Final”
*D	4303589	GVCH	03/12/2014	Figure 28: Updated Package diagram from *D to *E revision Sunset review: No technical updates
*E	4568786	GVCH	11/11/2014	Added related documentation hyperlink in page 1.

Sales, Solutions, and Legal Information

Worldwide Sales and Design Support

Cypress maintains a worldwide network of offices, solution centers, manufacturer’s representatives, and distributors. To find the office closest to you, visit us at [Cypress Locations](#).

Products

- Automotive cypress.com/go/automotive
- Clocks & Buffers cypress.com/go/clocks
- Interface cypress.com/go/interface
- Lighting & Power Control cypress.com/go/powerpsoc
cypress.com/go/plc
- Memory cypress.com/go/memory
- Optical & Image Sensing cypress.com/go/image
- PSoC cypress.com/go/psoc
- Touch Sensing cypress.com/go/touch
- USB Controllers cypress.com/go/USB
- Wireless/RF cypress.com/go/wireless

PSoC Solutions

- psoc.cypress.com/solutions
- PSoC 1 | PSoC 3 | PSoC 5

© Cypress Semiconductor Corporation, 2011-2014. The information contained herein is subject to change without notice. Cypress Semiconductor Corporation assumes no responsibility for the use of any circuitry other than circuitry embodied in a Cypress product. Nor does it convey or imply any license under patent or other rights. Cypress products are not warranted nor intended to be used for medical, life support, life saving, critical control or safety applications, unless pursuant to an express written agreement with Cypress. Furthermore, Cypress does not authorize its products for use as critical components in life-support systems where a malfunction or failure may reasonably be expected to result in significant injury to the user. The inclusion of Cypress products in life-support systems application implies that the manufacturer assumes all risk of such use and in doing so indemnifies Cypress against all charges.



Any Source Code (software and/or firmware) is owned by Cypress Semiconductor Corporation (Cypress) and is protected by and subject to worldwide patent protection (United States and foreign), United States copyright laws and international treaty provisions. Cypress hereby grants to licensee a personal, non-exclusive, non-transferable license to copy, use, modify, create derivative works of, and compile the Cypress Source Code and derivative works for the sole purpose of creating custom software and/or firmware in support of licensee product to be used only in conjunction with a Cypress integrated circuit as specified in the applicable agreement. Any reproduction, modification, translation, compilation, or representation of this Source Code except as specified above is prohibited without the express written permission of Cypress.

Disclaimer: CYPRESS MAKES NO WARRANTY OF ANY KIND, EXPRESS OR IMPLIED, WITH REGARD TO THIS MATERIAL, INCLUDING, BUT NOT LIMITED TO, THE IMPLIED WARRANTIES OF MERCHANTABILITY AND FITNESS FOR A PARTICULAR PURPOSE. Cypress reserves the right to make changes without further notice to the materials described herein. Cypress does not assume any liability arising out of the application or use of any product or circuit described herein. Cypress does not authorize its products for use as critical components in life-support systems where a malfunction or failure may reasonably be expected to result in significant injury to the user. The inclusion of Cypress’ product in a life-support systems application implies that the manufacturer assumes all risk of such use and in doing so indemnifies Cypress against all charges.

Use may be limited by and subject to the applicable Cypress software license agreement.

Looking for pricing, stock, or lifecycle information?

Click below to explore more details on WIN SOURCE:

-  [View CY14V101Q3-SFXI on WIN SOURCE](#)
-  [Cypress Semiconductor Corp Information](#)

Optimize Your Supply Chain with WIN SOURCE Solutions

-  Global Sourcing Solution
-  Obsolete Management
-  Cost Control Management
-  Shortage Management
-  Alternative Solution
-  Excess Inventory Management