



PROGRAMMABLE FLEXPC™ CLOCK FOR P4 PROCESSOR

IDTCV115-4

FEATURES:

- One high precision N Programming PLL for CPU
- One high precision N Programming PLL for SRC/PCI
- One high precision PLL for SATA
- One high precision PLL for 48MHz
- Band-gap circuit for differential outputs
- Support multiple spread spectrum modulation, down and center
- Support SMBus block read/write, index read/write
- Selectable output strength for REF, PCI, and 48MHz
- Available in SSOP package

KEY SPECIFICATION:

- CPU/SRC CLK cycle to cycle jitter < 85ps
- SATA CLK cycle to cycle jitter < 85ps
- Static PLL frequency divide error ≤ 114 ppm
- Static PLL frequency divide error for 48MHz ≤ 5 ppm

DESCRIPTION:

IDTCV115-4 is a 56 pin clock device, complying the latest Intel CK410 requirements, for Intel advance P4 processors. The CPU output buffer is designed to support up to 400MHz processor. One dedicated PLL for Serial ATA clock provides high accuracy frequency. This device also implements Band-gap referenced I_{REF} to reduce the impact of V_{DD} variation on differential outputs, which can provide more robust system performance.

Each CPU/SRC/PCI, SATA clock has its own Spread Spectrum selection, which allows for isolated changes instead of affecting other clock groups.

FUNCTIONAL BLOCK DIAGRAM

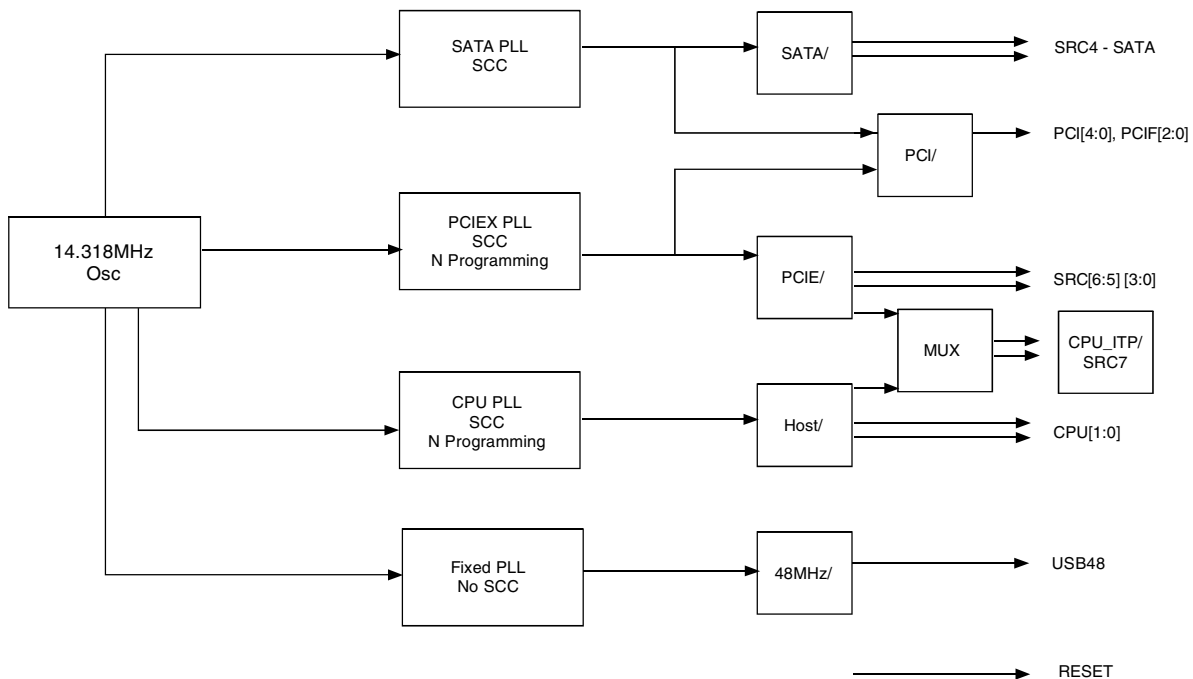

OUTPUT TABLE

CPU	CPU_ITP/SRC	SRC	SATA	PCI/PCIF	REF	REF/PCI	48MHz	RESET	TURBO
2	1	6	1	8	1	1	1	1	2

The IDT logo is a registered trademark of Integrated Device Technology, Inc.

COMMERCIAL TEMPERATURE RANGE

NOVEMBER 2004

PIN CONFIGURATION

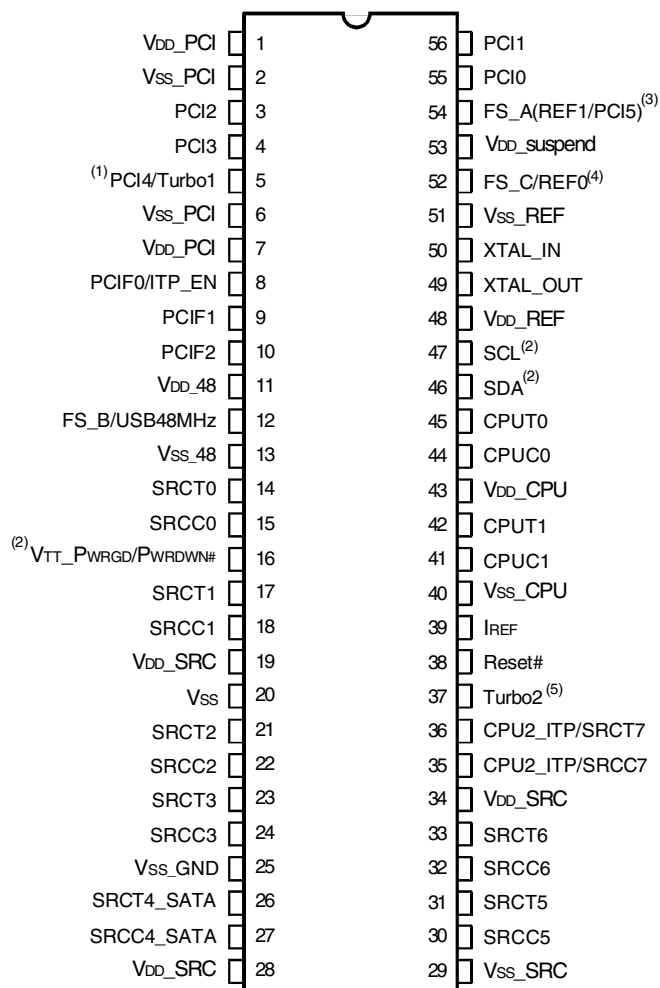

NOTES:

1. After power on, default is disabled Turbo mode (see SMBus Control Register Byte 30), tristate.
2. ~ 130KΩ internal pull-up.
3. After power on, pin 54 default is REF1 (see Byte 1).
4. REF0 is default 2x drive at power on (see Byte 0).
5. Turbo2 is disabled at power on, enabled by Byte 26.

**SSOP
TOP VIEW**

HW FREQUENCY SELECTION TABLE

FSC, B, A	CPU	SRC4_SATA	SRC[3:1], SCR[7:5]	PCI	USB	DOT	REF
101	100	100	100	33.3	48	96	14.318
001	133	100	100	33.3	48	96	14.318
011	166	100	100	33.3	48	96	14.318
010	200	100	100	33.3	48	96	14.318
000	266	100	100	33.3	48	96	14.318
100	333	100	100	33.3	48	96	14.318
110	400	100	100	33.3	48	96	14.318
111	Reserve	100	100	33.3	48	96	14.318

TEST MODE SELECT⁽¹⁾

If TEST_SEL sampled above 2V at V_{TT_PWRGD} active LOW

Pin38 (test_mode)	CPU	SRC	PCI/F	REF	DOT96	USB
1	REF/N	REF/N	REF/N	REF	REF/N	REF/N
0	Hi-Z	Hi-Z	Hi-Z	Hi-Z	Hi-Z	Hi-Z

NOTE:

1. Once test clock operation has been invoked, TEST_MODE pin will select between the Hi-Z and REF/N,

ITP_EN

ITP_EN	pin 35	pin 36
1	CPUC2_ITP	CPUT_ITP
0	SRCC7	SRCT7

PIN DESCRIPTION

Pin Number	Name	Type	Description
1	V _{DD_PCI}	PWR	3.3V
2	V _{SS_PCI}	GND	GND
3	PCI2	OUT	PCI clock
4	PCI3	OUT	PCI clock
5	PCI4/Turbo1	OUT	PCI clock output or Turbo input. Byte 30, bit 3 mode selection. Byte 30, bit 3 = 1, PCI clock. Byte 30, bit 3 = 0 Turbo mode. In Turbo mode, 1 = load TCN and TPN into CPU and SRC PLL.
6	V _{SS_PCI}	GND	GND
7	V _{DD_PCI}	PWR	3.3V
8	PCIF0/ITP_EN	I/O	PCI clock, free running. CPU_2 select (sampled at V _{TT_PWRGD} assertion), HIGH = CPU_2.
9	PCIF1	OUT	PCI clock,
10	PCIF2	OUT	PCI clock,
11	V _{DD_48}	PWR	3.3V
12	FS_B/USB48	I/O	CPU Frequency selection. 48MHz afterward.
13	V _{SS_48}	GND	GND
14	SRCT0	OUT	Differential Serial reference clock
15	SRCC0	OUT	Differential Serial reference clock
16	V _{TT_PWRGD} /PWRDWN#	I/O	3.3V LVTTTL input is a level-sensitive strobe used to latch the FS_A, FS_B, FS_C/TEST_SEL and PCIF_0/ITP_EN inputs. After V _{TT_PWRGD} assertion, active HIGH, becomes a real-time input for asserting power down (active LOW). Internal pull HIGH.
17	SRCT1	OUT	Differential Serial reference clock
18	SRCC1	OUT	Differential Serial reference clock
19	V _{DD_SRC}	PWR	3.3V
20	V _{SS}	GND	GND
21	SRCT2	OUT	Differential Serial reference clock
22	SRCC2	OUT	Differential Serial reference clock
23	SRCT3	OUT	Differential Serial reference clock
24	SRCC3	OUT	Differential Serial reference clock
25	V _{SS}	GND	GND
26	SRCT4_SATA	OUT	SATA clock
27	SRCC4_SATA	OUT	SATA clock
28	V _{DD_SRC}	PWR	3.3V
29	V _{SS_SRC}	GND	GND
30	SRCC5	OUT	Differential Serial reference clock
31	SRCT5	OUT	Differential Serial reference clock
32	SRCC6	OUT	Differential Serial reference clock
33	SRCT6	OUT	Differential Serial reference clock
34	V _{DD_SRC}	PWR	3.3V
35	CPUC2_ITP/ SRCC7	OUT	Selectable CPU or SRC differential clock output. ITP_EN=0 @ V _{TT_PWRGD} assertion = SRC_7
36	CPUT2_ITP/ SRCT7	OUT	Selectable CPU or SRC differential clock output. ITP_EN=0 @ V _{TT_PWRGD} assertion = SRC_7
37	Turbo2	IN	Load TCN2 into CPU PLL. Byte 26, bit 7 enable control. Disabled at power on.
38	Reset#	OUT	Reset output
39	IREF	OUT	Reference current for differential output buffer
40	V _{SS}	GND	GND
41	CPUC1	OUT	Host 0.7V current mode differential clock output
42	CPUT1	OUT	Host 0.7V current mode differential clock output
43	V _{DD_CPU}	PWR	3.3V
44	CPUC0	OUT	Host 0.7V current mode differential clock output
45	CPUT0	OUT	Host 0.7V current mode differential clock output
46	SDA	I/O	SMBus data

PIN DESCRIPTION (CONT.)

Pin Number	Name	Type	Description
47	SCL	IN	SMBus CLK
48	VDD_REF	PWR	3.3V
49	XTAL_OUT	OUT	Xtal output
50	XTAL_IN	IN	Xtal input
51	VSS_REF	GND	GND
52	FS_C/REF0	I/O	CPU frequency selection input at VTT_PWRGD assertion. 14.318 reference clock output afterward.
53	VDD_Suspend	POWER	Keep supply 3.3V in the power down
54	FS_A(REF1/PCI5)	I/O	CPU frequency selection input at VTT_PWRGD assertion. 14.318 or PCI reference clock output afterward, SMBus selectable. At power on, default is REF1.
55	PCI0	OUT	PCI clock
56	PCI1	OUT	PCI clock

SM PROTOCOL

INDEX BLOCK WRITE PROTOCOL

Bit	# of bits	From	Description
1	1	Master	Start
2-9	8	Master	D2h
10	1	Slave	Ack (Acknowledge)
11-18	8	Master	Register offset byte (starting byte)
19	1	Slave	Ack (Acknowledge)
20-27	8	Master	Byte count, N, (0 is not valid)
28	1	Slave	Ack (Acknowledge)
29-36	8	Master	first data byte (Offset data byte)
37	1	Slave	Ack (Acknowledge)
38-45	8	Master	2nd data byte
46	1	Slave	Ack (Acknowledge)
			:
		Master	Nth data byte
		Slave	Acknowledge
		Master	Stop

INDEX BLOCK READ PROTOCOL

Master can stop reading any time by issuing the stop bit without waiting until Nth byte (byte count bit30-37).

Bit	# of bits	From	Description
1	1	Master	Start
2-9	8	Master	D2H
10	1	Slave	Ack (Acknowledge)
11-18	8	Master	Register offset byte (starting byte)
19	1	Slave	Ack (Acknowledge)
20	1	Master	Repeated Start
21-28	8	Master	D3H
29	1	Slave	Ack (Acknowledge)
30-37	8	Slave	Byte count, N (block read back of N bytes), Byte 8
38	1	Master	Ack (Acknowledge)
39-46	8	Slave	first data byte (Offset data byte)
47	1	Master	Ack (Acknowledge)
48-55	8	Slave	2nd data byte
			Ack (Acknowledge)
			:
		Master	Ack (Acknowledge)
		Slave	Nth data byte
			Not acknowledge
		Master	Stop

INDEX BYTE WRITE

Setting bit[11:18] = starting address, bit[20:27] = 01h.

INDEX BYTE READ

Setting bit[11:18] = starting address. After reading back the first data byte, master issues Stop bit.

CB1_[2:0], CB2_[2:0], CPU MODE SELECTION

CB[2:0]	CPU Mode, MHz
101	100
001	133
011	166
010	200
000	266
100	333
110	400
111	RESERVE

RESOLUTION

	N Resolution (MHz)	%	N =
CPU = 100MHz mode	0.666667	0.67%	150
CPU = 133MHz mode	0.888889	0.67%	150
CPU = 166MHz mode	1.333333	0.8%	125
CPU = 200MHz mode	1.333333	0.67%	150
CPU = 266MHz mode	2.666667	1.00%	100
CPU = 333MHz mode	2.666667	0.8%	125
CPU = 400MHz mode	2.666667	0.67%	150
SRC (PCI Express)	0.666667	0.67%	150

SSC MAGNITUDE CONTROL

SMC[2:0]	%
000	OFF
001	-0.25
010	-0.5
011	±0.125
100	±0.25
101	±0.375
110	±0.5
111	±0.75

PCI

When Byte5 bit6 = 0

PCIS[1:0]	PCI
00	33.33
01	36.36
10	40
11	

S_CBS[1:0], H_CBS[1:0] BAND SELECTION

CBS[1:0]	
00	FS[C,B,A]
01	CB1_[2:0]
10	CB2_[2:0]
11	Don'tcare

S_CNS, S_PNS, H_CNS, H_PNS N SELECTION

NS[1:0]	
00	Standard of Each CPU Mode (Band)
01	N Selection 1
10	N Selection 2
11	Don't care

S.E. CLOCK STRENGTH SELECTION (PCI, REF, USB48)

Str[1:0]		Multiple loads	Single loads	USB48
00	2L	Recommend		Recommend
01	1H		Recommend	
10	1L		Recommend	
11	2H	Recommend		Recommend

BYTE 0

Bit	Output(s) Affected	Description/Function	0	1	Type	Power On
7	CPUT2, CPUC2/ SRCT7, SRCC7	Output enable	Tristate	Enable	RW	1
6	SRCT6, SRCC6	Output enable	Tristate	Enable	RW	1
5	SRCT5, SRCC5	Output enable	Tristate	Enable	RW	1
4	SRCT4, SRCC4 (SATA)	Output enable	Tristate	Enable	RW	1
3	SRCT3, SRCC3	Output enable	Tristate	Enable	RW	1
2	SRCT2, SRCC2	Output enable	Tristate	Enable	RW	1
1	SRCT1, SRCC1	Output enable	Tristate	Enable	RW	1
0	REF0 2x drive	2x drive enable	1x	2x	RW	1

BYTE 1

Bit	Output(s) Affected	Description/Function	0	1	Type	Power On	Recommended
7	SRC0	Output enable	Tristate	Enable	RW	1	
6	24_48	Not bonded out	Tristate	Enable	RW	1	0
5	USB48	Output enable	Tristate	Enable	RW	1	
4	REF1/PCI5	Mode Select	PCI5	REF1	RW	1	
3	REF0	Output enable	Tristate	Enable	RW	1	
2	CPUT1, CPUC1	Output enable	Tristate	Enable	RW	1	
1	CPUT0, CPUC0	Output enable	Tristate	Enable	RW	1	
0	REF1/PCI5	Output enable	Tristate	Enable	RW	1	

BYTE 2

Bit	Output(s) Affected	Description/Function	0	1	Type	Power On
7	PCI4	Output enable	Tristate	Enable	RW	1
6	PCI3	Output enable	Tristate	Enable	RW	1
5	PCI2	Output enable	Tristate	Enable	RW	1
4	PCI1	Output enable	Tristate	Enable	RW	1
3	PCI0	Output enable	Tristate	Enable	RW	1
2	PCIF2	Output enable	Tristate	Enable	RW	1
1	PCIF1	Output enable	Tristate	Enable	RW	1
0	PCIF0	Output enable	Tristate	Enable	RW	1

BYTE 3

Bit	Output(s) Affected	Description / Function	0	1	Type	Power On
7		FSC latched value on power up			R	
6		FSB latched value on power up			R	
5		FSA latched value on power up			R	
4	SRCT[7:1]	SRCT Pwrdsn drive mode	Driven in power down	Tristate in power down	RW	0
3	CPUT2	CPUT2 Pwrdsn drive mode	Driven in power down	Tristate in power down	RW	0
2	CPUT1	CPUT1 Pwrdsn drive mode	Driven in power down	Tristate in power down	RW	0
1	CPUT0	CPUT0 Pwrdsn drive mode	Driven in power down	Tristate in power down	RW	0
0	SRC0	SRC0 power down drive mode	Driven in power down	Tristate	RW	0

BYTE 4

Bit	Output(s) Affected	Description / Function	0	1	Type	Power On
7	PCIFStr1	PCIF strength selection				0
6	PCIFStr0					0
5	PCIStrC1	PCI strength selection				0
4	PCIStrC0					1
3	REFStr1	REF strength selection				0
2	REFStr0					0
1	48MHStr1	USB48MHz0 strength selection				1
0	48MHzStr0					1

BYTE 5

Bit	Output(s) Affected	Description / Function	0	1	Type	Power On
7						0
6	PCIPLLS	PCI PLL select	SATA PLL	PCI EX PLL	RW	0
5	PCIS1	See PCIS table, only valid when Byte5 bit 6 = 0 See PCIS Table			RW	0
4	PCIS0				RW	0
3	SM control registers contents	During the Power Down	Reset SM to default	SM contents have no change	RW	1
2	SATA_SMC2	SATA PLL spread spectrum magnitude control select (see SMC table)			RW	0
1	SATA_SMC1				RW	1
0	SATA_SMC0				RW	0

BYTE 6

Bit	Output(s) Affected	Description / Function	0	1	Type	Power On
7	WDHRB	Hard Alarm read back, reset by WD disable			R	
6	WDSRB	Soft Alarm read back, rest by WD disable			R	
5	SRC_SMC2	SRC(PCIExpress) PLL spread spectrum magnitude control select (see SMC table)			RW	0
4	SRC_SMC1				RW	1
3	SRC_SMC0				RW	0
2	CPU_SMC2	CPU PLL spread spectrum control magnitude select (see SMC table)			RW	1
1	CPU_SMC1				RW	0
0	CPU_SMC0				RW	0

BYTE 7

Bit	Output(s) Affected	Description / Function	0	1	Type	Power On
7		Revision ID				0
6		Revision ID				0
5		Revision ID				0
4		Revision ID				0
3		Vendor ID				0
2		Vendor ID				1
1		Vendor ID				0
0		Vendor ID				1

BYTE 8

Bit	Output(s) Affected	Description / Function	0	1	Type	Power On
7					RW	0
6					RW	0
5					RW	0
4					RW	1
3					RW	1
2					RW	1
1					RW	1
0					RW	1

BYTES 9 - 16 ARE DUMMY BITES

BYTE 17

Bit	Output(s) Affected	Description / Function	0	1	Type	Power On
7	CB1_2	CPU PLL Band Selection 1 (see CPU Mode Selection table)			RW	0
6	CB1_1				RW	0
5	CB1_0				RW	0
4					RW	0
3	CB2_2	CPU PLL Band Selection 2 (see CPU Mode Selection table)			RW	0
2	CB2_1				RW	0
1	CB2_0				RW	0
0	CN1_8 (MSB)	CPU PLL N selection 1			RW	0

BYTE 18

Bit	Output(s) Affected	Description / Function	0	1	Type	Power On
7	CN1_7	CPU PLL N selection 1 CPU Frequency = N * Resolution (see Resolution table)			RW	1
6	CN1_6				RW	0
5	CN1_5				RW	0
4	CN1_4				RW	1
3	CN1_3				RW	0
2	CN1_2				RW	1
1	CN1_1				RW	1
0	CN1_0 (LSB)				RW	0

BYTE 19

Bit	Output(s) Affected	Description / Function	0	1	Type	Power On
7	CN2_8 (MSB)	CPU N selection 2 CPU Frequency = N * Resolution (see Resolution table)				0
6	CN2_7					1
5	CN2_6					0
4	CN2_5					0
3	CN2_4					1
2	CN2_3					0
1	CN2_2					1
0	CN2_1					1

BYTE 20

Bit	Output(s) Affected	Description / Function	0	1	Type	Power On
7	CN2_0 (LSB)	CPU N selection 2				0
6						0
5						0
4						0
3						0
2						0
1	PN1_8 (MSB)				RW	0
0	PN1_7				RW	1

BYTE 21

Bit	Output(s) Affected	Description / Function	0	1	Type	Power On
7	PN1_6	SRC PLL (PCI Express) N Selection 1 SRC Frequency = N * Resolution Resolution = 0.666667			RW	0
6	PN1_5				RW	0
5	PN1_4				RW	1
4	PN1_3				RW	0
3	PN1_2				RW	1
2	PN1_1				RW	1
1	PN1_0 (LSB)				RW	0
0	PN2_8 (MSB)				RW	0

BYTE 22

Bit	Output(s) Affected	Description / Function	0	1	Type	Power On
7	PN2_7	SRC PLL (PCI Express) N Selection 1 SRC Frequency = N * Resolution Resolution = 0.666667			RW	1
6	PN2_6				RW	0
5	PN2_5				RW	0
4	PN2_4				RW	1
3	PN2_3				RW	0
2	PN2_2				RW	1
1	PN2_1				RW	1
0	PN2_0 (LSB)				RW	0

BYTE 23

Bit	Output(s) Affected	Description / Function	0	1	Type	Power On
7	S_CBS1	Soft Alarm CPU PLL mode select (see S_CBS Band Selection Table)			RW	0
6	S_CBS0				RW	0
5	S_CNS1	Soft Alarm CPU PLL N select (see S_CNS N Selection Table)			RW	0
4	S_CNS0				RW	0
3	S_PNS1	Soft Alarm SRC PLL (PCI Express) N select (see S_PNS N Selection Table)			RW	0
2	S_PNS0				RW	0
1						0
0						0

BYTE 24

Bit	Output(s) Affected	Description / Function	0	1	Type	Power On
7	H_CBS1	Hard Alarm CPU PLL mode select (see H_CBS Band Selection table)			RW	0
6	H_CBS0				RW	0
5	H_CNS2	Hard Alarm CPU PLL N select (see H_CNS N Selection table)			RW	0
4	H_CNS0				RW	0
3	H_PNS1	Hard Alarm SRC PLL (PCI Express) N select (see H_PNS N selection table)			RW	0
2	H_PNS0				RW	0
1						0
0						0

BYTE 25

Bit	Output(s) Affected	Description / Function	0	1	Type	Power On
7	WD Timer 7 (MSB)	Hard Alarm timer			RW	0
6	WD Timer 6	Default is 11*290ms			RW	0
5	WD Timer 5				RW	0
4	WD Timer 4				RW	0
3	WD Timer 3				RW	1
2	WD Timer 2				RW	0
1	WD Timer 1				RW	1
0	WD Timer 0 (LSB)				RW	1

BYTE 26

Bit	Output(s) Affected	Description / Function	0	1	Type	Power On
7	Turbo2	Turbo Enable	Disable	Enable	RW	0
6					RW	0
5					RW	0
4					RW	0
3	Soft Timer 3 (MSB)	Soft alarm timer			RW	0
2	Soft Timer 2				RW	0
1	Soft Timer 1				RW	0
0	Soft Timer 0 (LSB)				RW	1

BYTE 27

Bit	Output(s) Affected	Description / Function	0	1	Type	Power On
7	Watch Dog Enable	Watch Dog Enable	Disable	Enable	RW	0
6						0
5	Soft Alarm Enable	Soft Alarm Enable	Disable	Enable	RW	0
4	Soft RESET#	Soft Reset Enable	Disable	Soft Reset Enable	RW	0
3	Hard Alarm Enable	Hard Alarm Enable	Disable	Enable	RW	0
2	Hard RESET#	Hard Reset Enable	Disable	Hard Reset Enable	RW	0
1	Hard Alarm FS Relatch Enable	Relatch FS[C, B, A] at Hard Alarm	Disable	Relatch	RW	0
0	TCN8 (MSB)				RW	0

BYTE 28

Bit	Output(s) Affected	Description / Function	0	1	Type	Power On
7	TCN7	Turbo CPU PLL N setting CPU Frequency = N * Resolution (see Resolution table)			RW	1
6	TCN6				RW	0
5	TCN5				RW	0
4	TCN4				RW	1
3	TCN3				RW	0
2	TCN2				RW	1
1	TCN1				RW	1
0	TCN0 (LSB)				RW	0

BYTE 29

Bit	Output(s) Affected	Description / Function	0	1	Type	Power On
7	TPN8 (MSB)	Turbo SRC PLL N setting SRC Frequency = N * Resolution Resolution = 0.666667				0
6	TPN7					1
5	TPN6					0
4	TPN5					0
3	TPN4					1
2	TPN3					0
1	TPN2					1
0	TPN1					1

BYTE 30

Bit	Output(s) Affected	Description / Function	0	1	Type	Power On
7	TPN0 (LSB)					0
6	TCN28					0
5		Test Mode entry control	Normal operation	Test mode, controlled by byte 30 bit 4		0
4		Only valid when Byte6 bit5 is high	Hi-Z	REF/N mode		0
3	PCI4/Turbo1	PCI4/Turbo1 Mode select	Turbo1	PCI4	RW	0
2	Turbo1		Disable	Enable	RW	0
1	Test_scl	On chip test mode enable	normal	SCLK=1, CLK outputs=1 SCLK=0, CLK outputs=0	RW	0
0	Test_hiz	CLK outputs enable	normal	CLK outputs=Tristate	RW	0

BYTE 31

Bit	Output(s) Affected	Description / Function	0	1	Type	Power On
7	TCN27	Turbo2 CPU PLL N setting				1
6	TCN26					0
5	TCN25					0
4	TCN24					1
3	TCN23					0
2	TCN22					1
1	TCN21					1
0	TCN20					0

PLL FREQUENCY PROGRAMMING PROCEDURES

The user changes PLL frequency through Soft Alarm or Hard Alarm. The Watch Dog circuit has to be enabled. Based on their application, the user may enable either one or both of the alarms.

User presets the CPU PLL Mode and N, and SRC PLL N value:

1. Set CPU PLL Mode, CB1 and CB2, byte17
2. Set CPU PLL N, CN1 and CN2, byte18 and byte19
3. Set SRC(PCI Express) PLL N, PN1 and PN2, byte21, 22

User selects the frequency for Soft Alarm and Hard Alarm, if enabled respectively:

4. Select Soft Alarm frequency, byte23
5. Select Hard Alarm frequency, byte24

User sets the Timer and enables the WD circuit for frequency switch:

6. Set Hard Alarm Timer, byte25
7. Set Soft Alarm Timer, byte 26
8. Enable Soft and Hard Alarm and RESET# bit (If user needs RESET# signal to reset the system), byte27
9. Enable Watch Dog (WDE), byte27

- Soft Reset# and Hard Reset# are valid only if Soft Alarm and Hard Alarm are enabled respectively.
- WDE Disable resets WDSRB and WDHRB.
- PCI CLK is selectable from SRC PLL or SATA PLL, byte5 bit6. If from SRC PLL, PCI frequency = 1/3 of SRC frequency. If from SATA, PCI is fixed to 3 selections, 33MHz, 36MHz and 40MHz, byte5 bit[5:4].

WD SOFT AND HARD ALARM/TIME OUT OPERATION

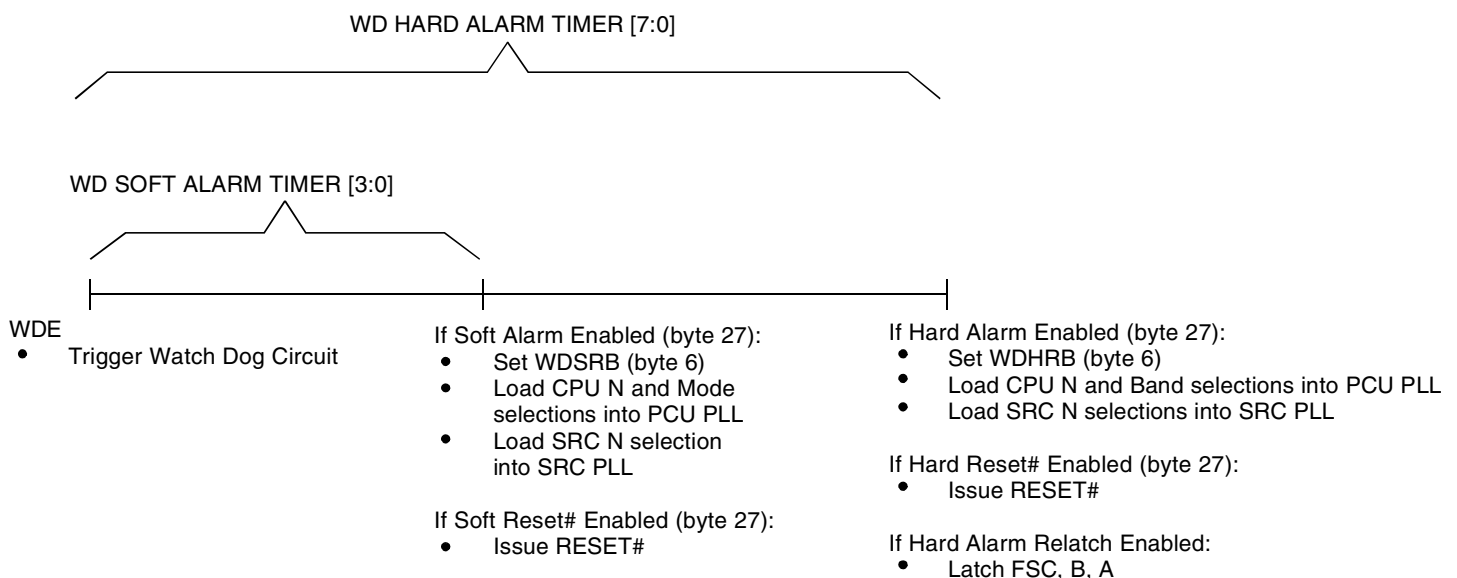

ELECTRICAL CHARACTERISTICS - INPUT / SUPPLY / COMMON OUTPUT PARAMETERS

Following Conditions Apply Unless Otherwise Specified:

Operating Condition: TA = 0°C to +70°C, Supply Voltage: VDD = 3.3V ± 5%

Symbol	Parameter	Test Conditions	Min.	Typ.	Max.	Unit
V _{IH}	Input HIGH Voltage	3.3V ± 5%	2	—	V _{DD} + 0.3	V
V _{IL}	Input LOW Voltage	3.3V ± 5%	V _{SS} - 0.3	—	0.8	V
V _{IH_FS}	FS Input HIGH Voltage	For FSA.B.C and Test_Mode	0.7	—	V _{DD} + 0.3	V
V _{IL_FS}	FS Input LOW Voltage	For FSA.B.C and Test_Mode	V _{SS} - 0.3	—	0.35	V
I _{IL}	Input Leakage Current	0 < V _{IN} < V _{DD} , no internal pull-up or pull-down	-5	—	+5	mA
I _{DD3.3OP}	Operating Supply Current	Full active, C _L = full load	—	—	400	mA
I _{DD3.3PD}	Powerdown Current	All differential pairs driven	—	—	70	mA
		All differential pairs tri-stated	—	—	12	
F _I	Input Frequency ⁽¹⁾	V _{DD} = 3.3V	—	14.31818	—	MHz
L _{PIN}	Pin Inductance ⁽²⁾		—	—	7	nH
C _{IN}	Input Capacitance ⁽²⁾	Logic inputs	—	—	5	pF
C _{OUT}		Output pin capacitance	—	—	6	
C _{INX}		X1 and X2 pins	—	—	5	
T _{STAB}	Clock Stabilization ^(2,3)	From V _{DD} power-up or de-assertion of PD# to first clock	—	—	1.8	ms
	Modulation Frequency ⁽²⁾	Triangular modulation	30	—	33	KHz
	T _{DRIVE_SRC} ⁽²⁾	SRC output enable after PCI_Stop# de-assertion	—	—	15	ns
	T _{DRIVE_PD#} ⁽²⁾	CPU output enable after PD# de-assertion	—	—	300	us
	T _{FALL_PD#} ⁽²⁾	Fall time of PD#	—	—	5	ns
	T _{RISE_PD#} ⁽³⁾	Rise time of PD#	—	—	5	ns
	T _{DRIVE_CPU_Stop#} ⁽²⁾	CPU output enable after CPU_Stop# de-assertion	—	—	10	us
	T _{FALL_CPU_Stop#} ⁽²⁾	Fall time of PD#	—	—	5	ns
	T _{RISE_CPU_Stop#} ⁽³⁾	Rise time of PD#	—	—	5	ns

NOTES:

1. Input frequency should be measured at the REF output pin and tuned to ideal 14.31818MHz to meet ppm frequency accuracy on PLL outputs.
2. This parameter is guaranteed by design, but not 100% production tested.
3. See TIMING DIAGRAMS for timing requirements.

ELECTRICAL CHARACTERISTICS - CPU, SRC, AND DOT96 0.7 CURRENT MODE DIFFERENTIAL PAIR⁽¹⁾

Following Conditions Apply Unless Otherwise Specified:

Operating Condition: TA = 0°C to +70°C, Supply Voltage: VDD = 3.3V ± 5%; CL = 2pF

Symbol	Parameter	Test Conditions	Min.	Typ.	Max.	Unit
ZO	Current Source Output Impedance ⁽²⁾	VO = Vx	3000	—	—	Ω
VOH3	Output HIGH Voltage	I _{OH} = -1mA	2.4	—	—	V
VOL3	Output LOW Voltage	I _{OL} = 1mA	—	—	0.4	V
VHIGH	Voltage HIGH ⁽²⁾	Statistical measurement on single-ended signal using oscilloscope math function	660	—	1150	mV
VLOW	Voltage LOW ⁽²⁾		-300	—	150	
VOVS	Max Voltage ⁽²⁾	Measurement on single-ended signal using absolute value	—	—	1150	mV
VUDS	Min Voltage ⁽²⁾		-300	—	—	
VCROSS(ABS)	Crossing Voltage (abs) ⁽²⁾		250	—	550	mV
d - VCROSS	Crossing Voltage (var) ⁽²⁾	Variation of crossing over all edges	—	—	140	mV
ppm	Long Accuracy ^(2,3)	See TPERIOD Min. - Max. values	-300	—	300	ppm
TPERIOD	Average Period ⁽³⁾	400MHz nominal / -0.5% spread	2.4993	—	2.5133	ns
		333.33MHz nominal / -0.5% spread	2.9991	—	3.016	
		266.66MHz nominal / -0.5% spread	3.7489	—	3.77	
		200MHz nominal / -0.5% spread	4.9985	—	5.0266	
		166.66MHz nominal / -0.5% spread	5.9982	—	6.032	
		133.33MHz nominal / -0.5% spread	7.4978	—	7.54	
		100MHz nominal / -0.5% spread	9.997	—	10.0533	
		96MHz nominal	10.4135	—	10.4198	
TABSMIN	Absolute Min Period ^(2,3)	400MHz nominal / -0.5% spread	2.4143	—	—	ns
		333.33MHz nominal / -0.5% spread	2.9141	—	—	
		266.66MHz nominal / -0.5% spread	3.6639	—	—	
		200MHz nominal / -0.5% spread	4.9135	—	—	
		166.66MHz nominal / -0.5% spread	5.9132	—	—	
		133.33MHz nominal / -0.5% spread	7.4128	—	—	
		100MHz nominal / -0.5% spread	9.912	—	—	
		96MHz nominal	10.1635	—	—	
tr	Rise Time ⁽²⁾	V _{OL} = 0.175V, V _{OH} = 0.525V	175	—	700	ps
tf	Fall Time ⁽²⁾	V _{OL} = 0.175V, V _{OH} = 0.525V	175	—	700	ps
d-tr	Rise Time Variation ⁽²⁾		—	—	125	ps
d-tf	Fall Time Variation ⁽²⁾		—	—	125	ps
dt3	Duty Cycle ⁽²⁾	Measurement from differential waveform	45	—	55	%

NOTES:

- SRC clock outputs run only at 100MHz.
- This parameter is guaranteed by design, but not 100% production tested.
- All long term accuracy and clock period specifications are guaranteed with the assumption that the REF output is at 14.31818MHz.

ELECTRICAL CHARACTERISTICS - CPU, SRC, AND DOT96 0.7 CURRENT MODE DIFFERENTIAL PAIR, CONTINUED⁽¹⁾

Following Conditions Apply Unless Otherwise Specified:

Operating Condition: TA = 0°C to +70°C, Supply Voltage: VDD = 3.3V ± 5%; CL = 2pF

Symbol	Parameter	Test Conditions	Min.	Typ.	Max.	Unit
tsk3	Skew, CPU[1:0] ⁽²⁾	VT = 50%	—	—	100	ps
	Skew, CPU2 ⁽²⁾		—	—	250	
	Skew, SRC ⁽²⁾		—	—	250	
tcyc-cyc	Jitter, Cycle to Cycle, CPU[1:0] ⁽²⁾	Measurement from differential waveform	—	—	85	ps
	Jitter, Cycle to Cycle, CPU2 ⁽²⁾		—	—	100	
	Jitter, Cycle to Cycle, SRC ⁽²⁾		—	—	125	

NOTES:

- SRC clock outputs run only at 100MHz.
- This parameter is guaranteed by design, but not 100% production tested.

ELECTRICAL CHARACTERISTICS - PCICLK / PCICLK_F

Following Conditions Apply Unless Otherwise Specified:

Operating Condition: TA = 0°C to +70°C, Supply Voltage: VDD = 3.3V ± 5%; CL = 10 - 30pF

Symbol	Parameter	Test Conditions	Min.	Typ.	Max.	Unit
ppm	Long Accuracy ^(1,2)	See Tperiod Min. - Max. values	—	—	300	ppm
TPERIOD	Clock Period ⁽²⁾	33.33MHz output nominal	29.991	—	30.009	ns
		33.33MHz output spread	29.991	—	30.1598	
VOH	Output HIGH Voltage	IOH = -1mA	2.4	—	—	V
VOL	Output LOW Voltage	IOL = 1mA	—	—	0.55	V
IOH	Output HIGH Current	VOH at Min. = 1V	-33	—	—	mA
		VOH at Max. = 3.135V	—	—	-33	
IOL	Output LOW Current	VOL at Min. = 1.95V	30	—	—	mA
		VOL at Max. = 0.4V	—	—	38	
	Edge Rate ⁽¹⁾	Rising edge rate	1	—	4	V/ns
	Edge Rate ⁽¹⁾	Falling edge rate	1	—	4	V/ns
tr1	Rise Time ⁽¹⁾	VOL = 0.8V, VOH = 2V	0.3	—	1.2	ns
tf1	Fall Time ⁽¹⁾	VOL = 0.8V, VOH = 2V	0.3	—	1.2	ns
dt1	Duty Cycle ⁽¹⁾	VT = 1.5V	45	—	55	%
tcyc-cyc	Jitter, Cycle to Cycle ⁽¹⁾	VT = 1.5V	—	—	500	ps

NOTES:

- This parameter is guaranteed by design, but not 100% production tested.
- All long term accuracy and clock period specifications are guaranteed with the assumption that the REF output is at 14.31818MHz.

ELECTRICAL CHARACTERISTICS - 48MHZ, USB

Following Conditions Apply Unless Otherwise Specified:

Operating Condition: TA = 0°C to +70°C, Supply Voltage: VDD = 3.3V ± 5%; CL = 10 - 20pF

Symbol	Parameter	Test Conditions	Min.	Typ.	Max.	Unit
ppm	Long Accuracy ^(1,2)	See Tperiod Min. - Max. values	—	—	300	ppm
TPERIOD	Clock Period ⁽²⁾	48MHz output nominal	20.8257	—	20.834	ns
VOH	Output HIGH Voltage	IOH = -1mA	2.4	—	—	V
VOL	Output LOW Voltage	IOL = 1mA	—	—	0.55	V
IOH	Output HIGH Current	VOH at Min. = 1V	-29	—	—	mA
		VOH at Max. = 3.135V	—	—	-23	
IOL	Output LOW Current	VOL at Min. = 1.95V	29	—	—	mA
		VOL at Max. = 0.4V	—	—	27	
	Edge Rate ⁽¹⁾	Rising edge rate	1	—	2	V/ns
	Edge Rate ⁽¹⁾	Falling edge rate	1	—	2	V/ns
tr1	Rise Time ⁽¹⁾	VOL = 0.8V, VOH = 2V	0.5	—	1.2	ns
tF1	Fall Time ⁽¹⁾	VOL = 0.8V, VOH = 2V	0.5	—	1.2	ns
dT1	Duty Cycle ⁽¹⁾	VT = 1.5V	45	—	55	%
tCYC-CYC	Jitter, Cycle to Cycle ⁽¹⁾	VT = 1.5V	—	—	350	ps

NOTES:

1. This parameter is guaranteed by design, but not 100% production tested.
2. All long term accuracy and clock period specifications are guaranteed with the assumption that the REF output is at 14.31818MHz.

ELECTRICAL CHARACTERISTICS - REF-14.318MHZ

Following Conditions Apply Unless Otherwise Specified:

Operating Condition: TA = 0°C to +70°C, Supply Voltage: VDD = 3.3V ± 5%; CL = 10 - 20pF

Symbol	Parameter	Test Conditions	Min.	Typ.	Max.	Unit
ppm	Long Accuracy ⁽¹⁾	See Tperiod Min. - Max. values	—	—	0	ppm
TPERIOD	Clock Period	14.318MHz output nominal	69.827	—	69.855	ns
VOH	Output HIGH Voltage ⁽¹⁾	IOH = -1mA	2.4	—	—	V
VOL	Output LOW Voltage ⁽¹⁾	IOL = 1mA	—	—	0.4	V
IOH	Output HIGH Current	VOH at Min. = 1V	-33	—	—	mA
		VOH at Max. = 3.135V	—	—	-33	
IOL	Output LOW Current	VOL at Min. = 1.95V	30	—	—	mA
		VOL at Max. = 0.4V	—	—	38	
	Edge Rate ⁽¹⁾	Rising edge rate	1	—	4	V/ns
	Edge Rate ⁽¹⁾	Falling edge rate	1	—	4	V/ns
tr1	Rise Time ⁽¹⁾	VOL = 0.8V, VOH = 2V	0.3	—	1.2	ns
tF1	Fall Time ⁽¹⁾	VOL = 0.8V, VOH = 2V	0.3	—	1.2	ns
dT1	Duty Cycle ⁽¹⁾	VT = 1.5V	45	—	55	%
tCYC-CYC	Jitter, Cycle to Cycle ⁽¹⁾	VT = 1.5V	—	—	1000	ps

NOTE:

1. This parameter is guaranteed by design, but not 100% production tested.

PD#, POWER DOWN

PD# is an asynchronous active low input used to shut off all clocks cleanly prior to clock power. When PD# is asserted low all clocks will be driven low before turning off the VCO. In PD# de-assertion all clocks will start without glitches.

PWRDWN#	CPU	CPU#	SRC	SRC#	PCIF/PCI	USB	DOT96	DOT96#	REF
1	Normal	Normal	Normal	Normal	33MHz	48MHz	Normal	Normal	14.318MHz
0	I _{REF} * 2 or float	Float	I _{REF} * 2 or float	Float	Low	Low	I _{REF} * 2 or float	Float	Low

PD# ASSERTION

PD# should be sampled low by two consecutive CPU# rising edges before stopping clocks. All single-ended clocks will be held low on their next high to low transition. All differential clocks will be held high on the next high to low transition of the complimentary clock. If the control register determining to drive mode is set to 'tri-state', the differential pair will be stopped in tri-state mode, undriven. When the drive mode but corresponding to the CPU or SRC clock of interest is set to '0' the true clock will be driven high at 2 x I_{REF} and the complementary clock will be tristated. If the control register is programmed to '1' both clocks will be tristated.

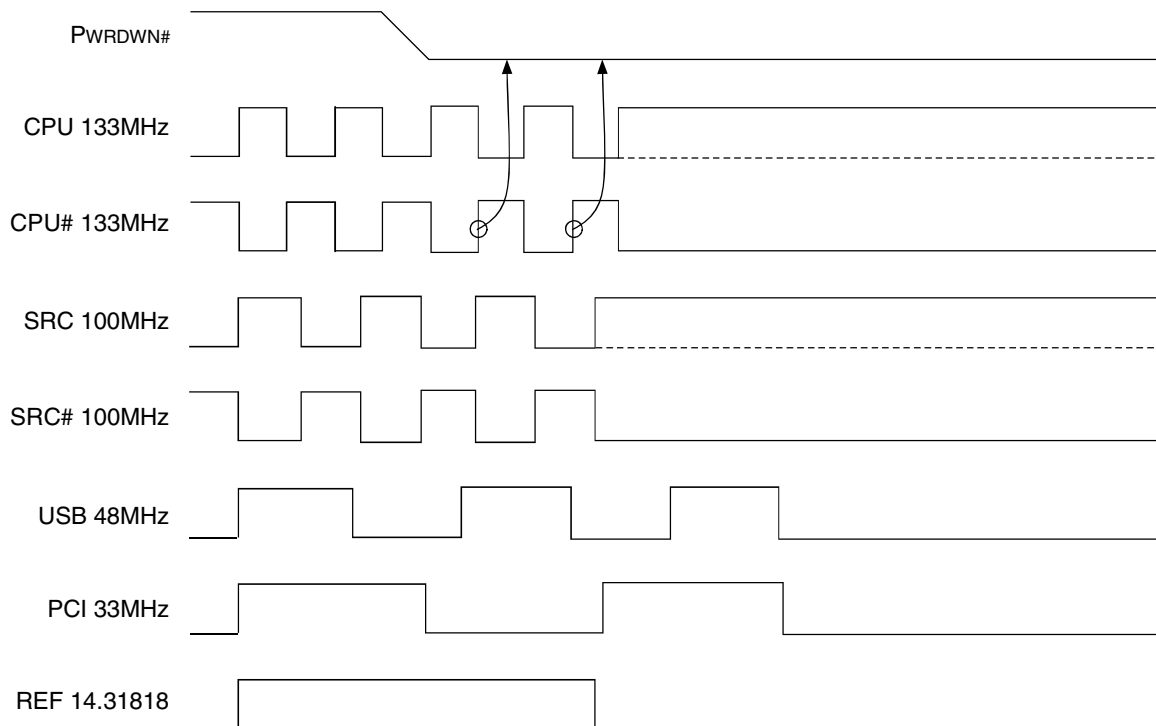

PD# DE-ASSERTION

The time from the de-assertion of PD# or until power supply ramps to get stable clocks will be less than 1.8ms. If the drive mode control bit for PD# tristate is programmed to '1' the stopped differential pair must first be driven high to a minimum of 200mV in less than 300µs of PD# deassertion.

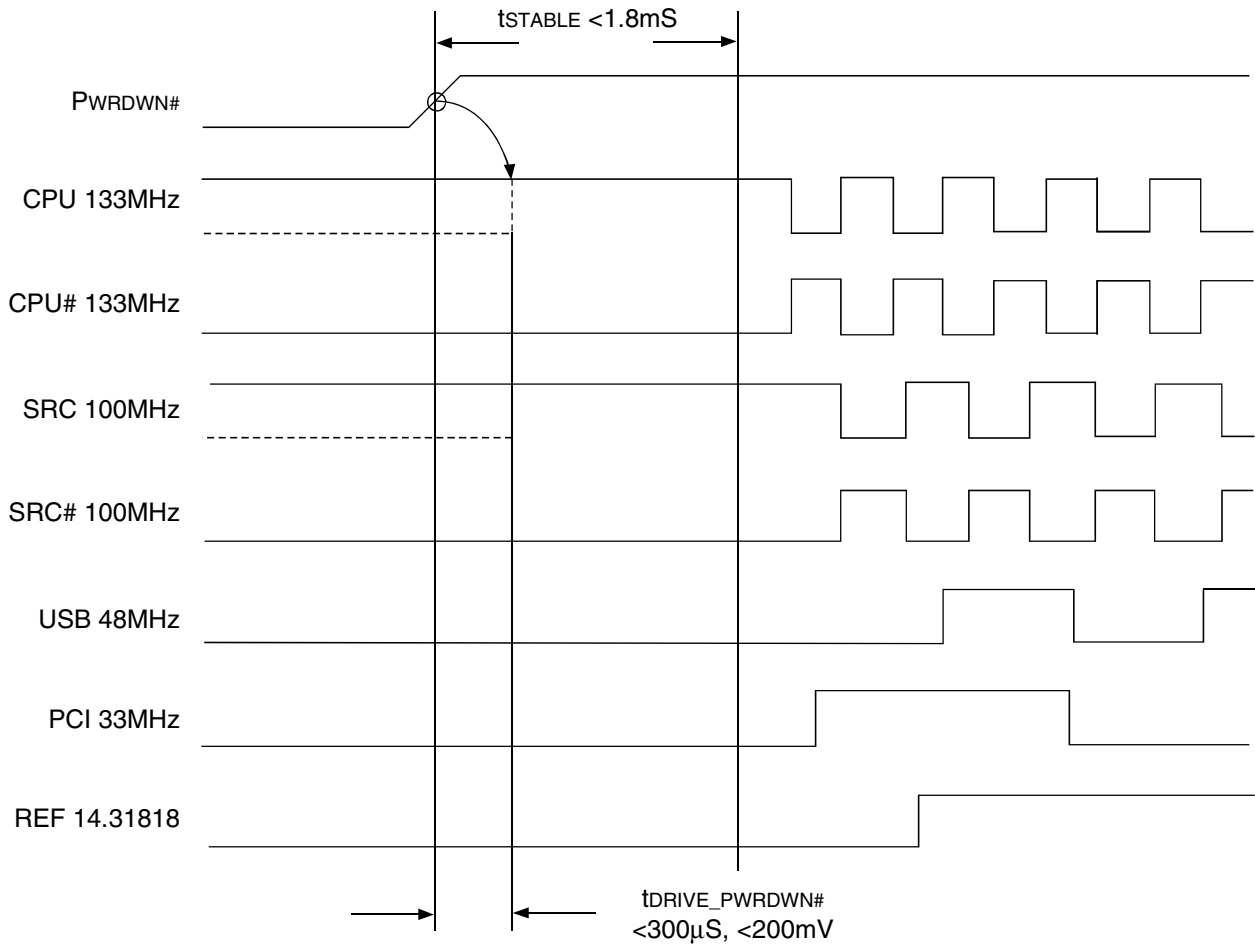

ORDERING INFORMATION

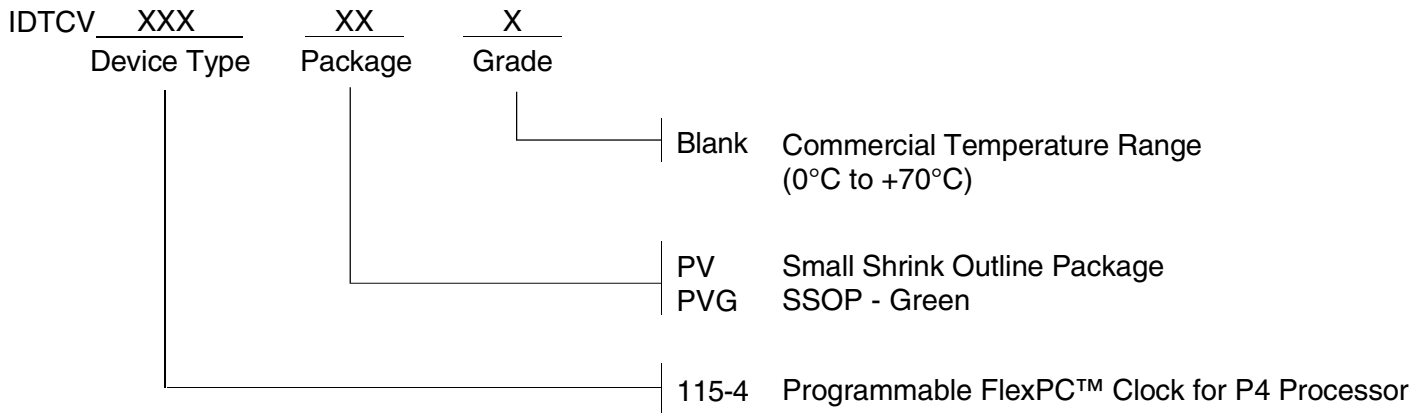

CORPORATE HEADQUARTERS
6024 Silver Creek Valley Road
San Jose, CA 95138

for SALES:
800-345-7015 or 408-284-8200
fax: 408-284-2775
www.idt.com

for Tech Support:
logichelp@idt.com

Looking for pricing, stock, or lifecycle information?

Click below to explore more details on WIN SOURCE:

- ⊖ [View IDTCV115-4PVG on WIN SOURCE](#)
- ⊖ [IDT, Integrated Device Technology Inc Information](#)

Optimize Your Supply Chain with WIN SOURCE Solutions

- ✓ Global Sourcing Solution
- ✓ Obsolete Management
- ✓ Cost Control Management
- ✓ Shortage Management
- ✓ Alternative Solution
- ✓ Excess Inventory Management