



**THE DATASHEET OF  
CSD95379Q3MT**



## CSD95379Q3M Synchronous Buck NexFET™ Power Stage

### 1 Features

- 92.5% System Efficiency at 12 A
- Ultra-Low Power Loss of 1.8 W at 12 A
- Max Rated Continuous Current of 20 A and Peak Current of 45 A
- High-Frequency Operation (up to 2 MHz)
- High-Density SON 3.3-mm x 3.3-mm Footprint
- Ultra-Low Inductance Package
- System Optimized PCB Footprint
- Low Quiescent (LQ) and Ultra-Low Quiescent (ULQ) Current Mode
- 3.3-V and 5-V PWM Signal Compatible
- Diode Emulation Mode with FCCM
- Tri-State PWM Input
- Integrated Bootstrap Diode
- Shoot-Through Protection
- RoHS Compliant – Lead-Free Terminal Plating
- Halogen Free

### 2 Applications

- NVDC Notebook and Ultrabook PCs
- Tablets
- Point of Load Synchronous Buck in Networking, Telecom, and Computing Systems

### 3 Description

The CSD95379Q3M NexFET™ power stage is a highly optimized design for use in high-power, high-density synchronous buck converters. This product integrates the driver IC and NexFET technology to complete the power stage switching function. The driver IC has a built-in selectable diode emulation function that enables DCM operation to improve light load efficiency. In addition, the driver IC supports ULQ mode that enables Connected Standby for Windows® 8. With the PWM input in tri-state, quiescent current is reduced to 130  $\mu$ A, with immediate response. When SKIP# is held at tri-state, the current is reduced to 8  $\mu$ A (typically 20  $\mu$ s is required to resume switching). This combination produces high-current, high-efficiency, and high-speed switching capability in a small 3.3-mm x 3.3-mm outline package. In addition, the PCB footprint has been optimized to help reduce design time and simplify the completion of the overall system design.

#### Device Information<sup>(1)</sup>

DEVICE	MEDIA	QTY	PACKAGE	SHIP
CSD95379Q3M	13-Inch Reel	2500	SON	Tape
CSD95379Q3MT	7-Inch Reel	250	3.3-mm x 3.3-mm Plastic Package	and Reel

(1) For all available packages, see the orderable addendum at the end of the data sheet.

Application Diagram

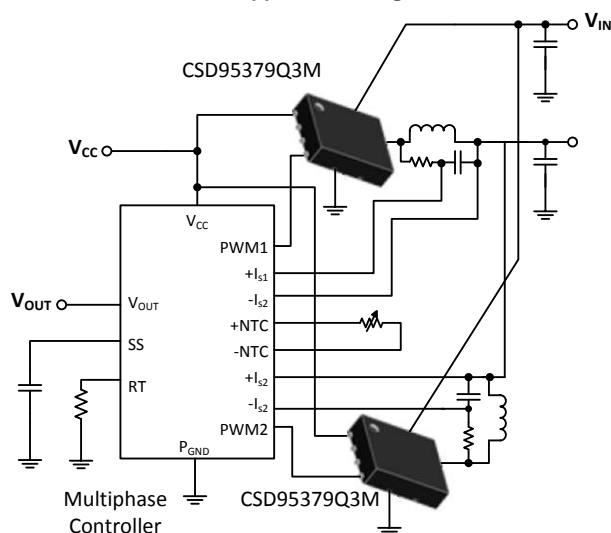

Typical Power Stage Efficiency and Power Loss

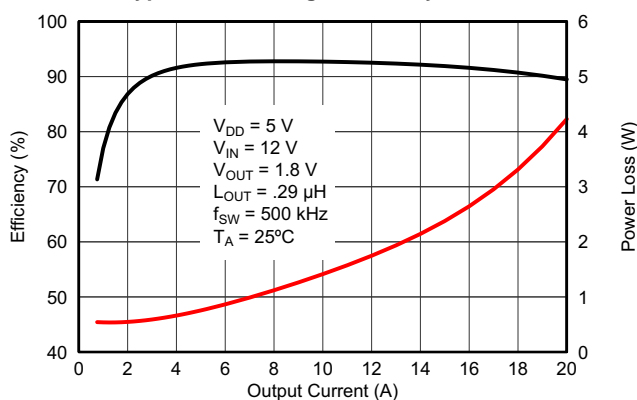

G001



## Table of Contents

<b>1 Features</b> .....	<b>1</b>	<b>8 Application and Implementation</b> .....	<b>11</b>
<b>2 Applications</b> .....	<b>1</b>	8.1 Application Information.....	11
<b>3 Description</b> .....	<b>1</b>	<b>9 Layout</b> .....	<b>14</b>
<b>4 Revision History</b> .....	<b>2</b>	9.1 Layout Guidelines .....	14
<b>5 Pin Configuration and Functions</b> .....	<b>3</b>	9.2 Layout Example .....	14
<b>6 Specifications</b> .....	<b>4</b>	<b>10 Device and Documentation Support</b> .....	<b>15</b>
6.1 Absolute Maximum Ratings .....	4	10.1 Receiving Notification of Documentation Updates .....	15
6.2 ESD Ratings.....	4	10.2 Community Resources.....	15
6.3 Recommended Operating Conditions.....	4	10.3 Trademarks .....	15
6.4 Thermal Information .....	4	10.4 Electrostatic Discharge Caution.....	15
6.5 Electrical Characteristics.....	5	10.5 Glossary .....	15
6.6 Typical Characteristics .....	6	<b>11 Mechanical, Packaging, and Orderable Information</b> .....	<b>16</b>
<b>7 Detailed Description</b> .....	<b>8</b>	11.1 Mechanical Drawing.....	16
7.1 Functional Block Diagram .....	8	11.2 Recommended PCB Land Pattern.....	17
7.2 Feature Description.....	8	11.3 Recommended Stencil Opening .....	17

## 4 Revision History

NOTE: Page numbers for previous revisions may differ from page numbers in the current version.

<b>Changes from Revision C (November 2014) to Revision D</b>	<b>Page</b>
• Added minimum value for $f_{SW}$ in the <i>Recommended Operating Conditions</i> table.....	4
• Added <i>Receiving Notification of Documentation Updates</i> and <i>Community Resources</i> to <i>Device and Documentation Support</i> section.....	15

---

<b>Changes from Revision B (November 2014) to Revision C</b>	<b>Page</b>
• Added footnote 1 under <i>Recommended Operating Conditions</i> .....	4

---

<b>Changes from Revision A (August 2014) to Revision B</b>	<b>Page</b>
• Changed device status to production data.....	1

---

<b>Changes from Original (April 2014) to Revision A</b>	<b>Page</b>
• Increased $V_{IN}$ from 14.5 V to 16 V.....	4

## 5 Pin Configuration and Functions

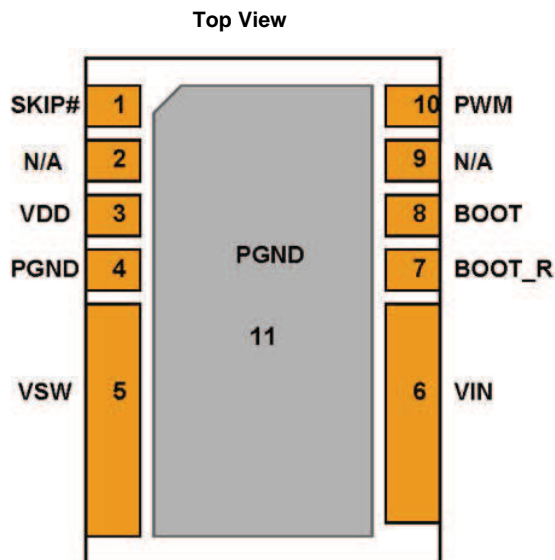

### Pin Functions

PIN		DESCRIPTION
NAME	NUMBER	
SKIP#	1	This pin enables the Diode Emulation function. When this pin is held low, Diode Emulation Mode is enabled for the sync FET. When SKIP# is high, the CSD95379Q3M operates in Forced Continuous Conduction Mode. A tri-state voltage on SKIP# puts the driver into a very-low power state.
V <sub>DD</sub>	3	Supply voltage to gate drivers and internal circuitry.
P <sub>GND</sub>	4	Power ground. Needs to be connected to pin 11 on the PCB.
V <sub>SW</sub>	5	Voltage switching node – pin connection to output inductor.
V <sub>IN</sub>	6	Input voltage pin. Connect input capacitors to close this pin.
BOOT_R	7	Bootstrap capacitor connection. Connect a minimum 0.1- $\mu$ F, 16-V X5R, ceramic capacitor from BOOT to BOOT_R pins. The bootstrap capacitor provides the charge to turn on the control FET. The bootstrap diode is integrated.
BOOT	8	
PWM	10	Pulse-width-modulated tri-state input from external controller. Logic low sets control FET gate low and sync FET gate high. Logic high sets control FET gate high and sync FET gate low. Open or High Z sets both MOSFET gates low if greater than the tri-state shutdown hold-off time ( $T_{3HT}$ ).
P <sub>GND</sub>	11	Power ground. Needs to be connected to pin 4 on the PCB.

## 6 Specifications

### 6.1 Absolute Maximum Ratings<sup>(1)</sup>

 $T_A = 25^\circ\text{C}$  (unless otherwise noted)

	MIN	MAX	UNIT
$V_{IN}$ to $P_{GND}$	-0.3	20	V
$V_{SW}$ to $P_{GND}$ , $V_{IN}$ to $V_{SW}$	-0.3	20	V
$V_{SW}$ to $P_{GND}$ , $V_{IN}$ to $V_{SW}$ (<10 ns)	-7	23	V
$V_{DD}$ to $P_{GND}$	-0.3	6	V
PWM, SKIP# to $P_{GND}$	-0.3	6	V
BOOT to $P_{GND}$	-0.3	25	V
BOOT to $P_{GND}$ (<10 ns)	-2	28	V
BOOT to BOOT_R	-0.3	6	V
$P_D$ Power dissipation		6	W
$T_J$ Operating temperature	-40	150	$^\circ\text{C}$
$T_{stg}$ Storage temperature	-55	150	$^\circ\text{C}$

- (1) Stresses above those listed in *Absolute Maximum Ratings* may cause permanent damage to the device. These are stress ratings only and functional operation of the device at these or any other conditions beyond those indicated under *Recommended Operating Conditions* is not implied. Exposure to absolute-maximum-rated conditions for extended periods may affect device reliability.

### 6.2 ESD Ratings

	VALUE	UNIT
$V_{(ESD)}$ Electrostatic discharge	Human-body model (HBM), per ANSI/ESDA/JEDEC JS-001, all pins <sup>(1)</sup>	$\pm 2000$
	Charged-device model (CDM), per JEDEC specification JESD22-C101, all pins <sup>(2)</sup>	$\pm 500$

- (1) JEDEC document JEP155 states that 500 V HBM allows safe manufacturing with a standard ESD control process.  
 (2) JEDEC document JEP157 states that 250 V CDM allows safe manufacturing with a standard ESD control process.

### 6.3 Recommended Operating Conditions

 $T_A = 25^\circ$  (unless otherwise noted)

	MIN	MAX	UNIT
$V_{DD}$ Gate drive voltage	4.5	5.5	V
$V_{IN}$ Input supply voltage <sup>(1)</sup>		16	V
$I_{OUT}$ Continuous output current		20	A
$I_{OUT-PK}$ Peak output current <sup>(3)</sup>		45	A
$f_{SW}$ Switching frequency	25	2000	kHz
On time duty cycle		85%	
Minimum PWM on time	40		ns
Operating temperature	-40	125	$^\circ\text{C}$

- (1) Operating at high  $V_{IN}$  can create excessive AC voltage overshoots on the switch node ( $V_{SW}$ ) during MOSFET switching transients. For reliable operation, the switch node ( $V_{SW}$ ) to ground voltage must remain at or below the *Absolute Maximum Ratings*.  
 (2) Measurement made with six 10  $\mu\text{F}$  (TDK C3216X5R1C106KT or equivalent) ceramic capacitors placed across  $V_{IN}$  to  $P_{GND}$  pins.  
 (3) System conditions as defined in Note 1. Peak output current is applied for  $t_p = 10$  ms, duty cycle  $\leq 1\%$ .

### 6.4 Thermal Information

 $T_A = 25^\circ\text{C}$  (unless otherwise noted)

THERMAL METRIC	MIN	TYP	MAX	UNIT
$R_{\theta JC(top)}$ Junction-to-case thermal resistance (top of package) <sup>(1)</sup>			22.8	$^\circ\text{C/W}$
$R_{\theta JB}$ Junction-to-board thermal resistance <sup>(2)</sup>			2.5	

- (1)  $R_{\theta JC(top)}$  is determined with the device mounted on a 1-in<sup>2</sup> (6.45-cm<sup>2</sup>), 2-oz (.071-mm) thick Cu pad on a 1.5-in x 1.5-in, 0.06-in (1.52-mm) thick FR4 board.  
 (2)  $R_{\theta JB}$  value based on hottest board temperature within 1 mm of the package.

## 6.5 Electrical Characteristics

 $T_A = 25^\circ\text{C}$ ,  $V_{DD} = \text{POR to } 5.5\text{ V}$  (unless otherwise noted)

PARAMETER		TEST CONDITIONS	MIN	TYP	MAX	UNIT
<b>P<sub>Loss</sub></b>						
Power loss <sup>(1)</sup>		$V_{IN} = 12\text{ V}$ , $V_{DD} = 5\text{ V}$ , $V_{OUT} = 1.8\text{ V}$ , $I_{OUT} = 12\text{ A}$ , $f_{SW} = 500\text{ kHz}$ , $L_{OUT} = 0.29\text{ }\mu\text{H}$ , $T_J = 25^\circ\text{C}$		1.8		W
Power loss <sup>(2)</sup>		$V_{IN} = 12\text{ V}$ , $V_{DD} = 5\text{ V}$ , $V_{OUT} = 1.8\text{ V}$ , $I_{OUT} = 12\text{ A}$ , $f_{SW} = 500\text{ kHz}$ , $L_{OUT} = 0.29\text{ }\mu\text{H}$ , $T_J = 125^\circ\text{C}$		2.3		W
<b>V<sub>IN</sub></b>						
$I_Q$	$V_{IN}$ quiescent current	PWM = float, $V_{IN} = 14.5\text{ V}$ , $V_{DD} = 5\text{ V}$			1	$\mu\text{A}$
<b>V<sub>DD</sub></b>						
$I_{DD}$	Standby supply current	PWM = float, VSKIP# = $V_{DD}$ or 0 V		130		$\mu\text{A}$
		VSKIP# = float		8		
$I_{DD}$	Operating supply current	PWM = 50% duty cycle, $f_{SW} = 500\text{ kHz}$		5.5		mA
<b>POWER-ON RESET AND UNDERVOLTAGE LOCKOUT</b>						
$V_{DD}$ rising	Power-on reset				4.15	V
$V_{DD}$ falling	UVLO		3.7			V
	Hysteresis			0.2		mV
<b>PWM AND SKIP# I/O SPECIFICATIONS</b>						
$R_I$	Input impedance	Pullup to $V_{DD}$		1700		k $\Omega$
		Pulldown to GND		800		
$V_{IH}$	Logic level high		2.65			V
$V_{IL}$	Logic level low			0.6		V
$V_{IH}$	Hysteresis			0.2		V
$V_{TS}$	Tri-state voltage		1.3		2	V
$t_{\text{HOLD(off1)}}$	Tri-state activation time (falling) PWM <sup>(2)</sup>			60		ns
$t_{\text{HOLD(off2)}}$	Tri-state activation time (rising) PWM <sup>(2)</sup>			60		ns
$t_{\text{TSKF}}$	Tri-state activation time (falling) SKIP# <sup>(2)</sup>			1		ns
$t_{\text{TSKR}}$	Tri-state activation time (rising) SKIP# <sup>(2)</sup>			1		ns
$t_{3\text{RD(PWM)}}$	Tri-state exit time PWM <sup>(2)</sup>				100	ns
$t_{3\text{RD(SKIP\#)}}$	Tri-state exit time SKIP# <sup>(2)</sup>				50	$\mu\text{s}$
<b>BOOTSTRAP SWITCH</b>						
$V_{\text{FBOOT}}$	Forward voltage	Measured from $V_{DD}$ to $V_{\text{BOOT}}$ , $I_F = 20\text{ mA}$		120	240	mV
$I_{\text{RBOOT}}$	Reverse leakage <sup>(1)</sup>	$V_{\text{BOOT}} - V_{DD} = 25\text{ V}$			2	$\mu\text{A}$

(1) Measurement made with six 10- $\mu\text{F}$  (TDK C3216X5R1C106KT or equivalent) ceramic capacitors placed across  $V_{IN}$  to  $P_{\text{GND}}$  pins.

(2) Specified by design.

## 6.6 Typical Characteristics

$T_J = 125^\circ\text{C}$ , unless stated otherwise. The Typical CSD95379Q3M system characteristic curves are based on measurements made on a PCB design with dimensions of 4 in (W) x 3.5 in (L) x 0.062 in (T) and 6 copper layers of 1-oz copper thickness. See the [Application and Implementation](#) section for detailed explanation.

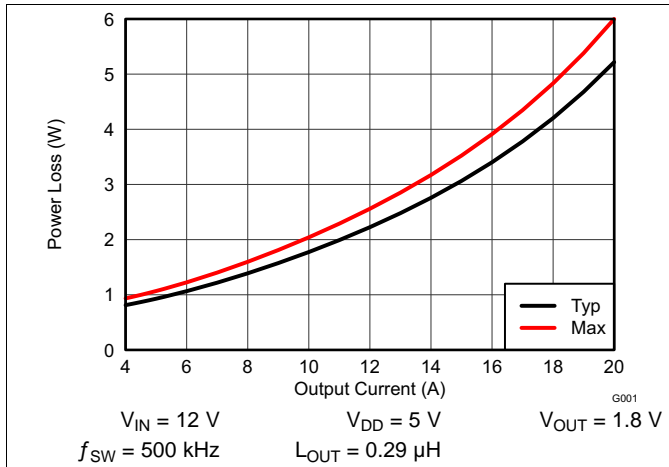

Figure 1. Power Loss vs Output Current

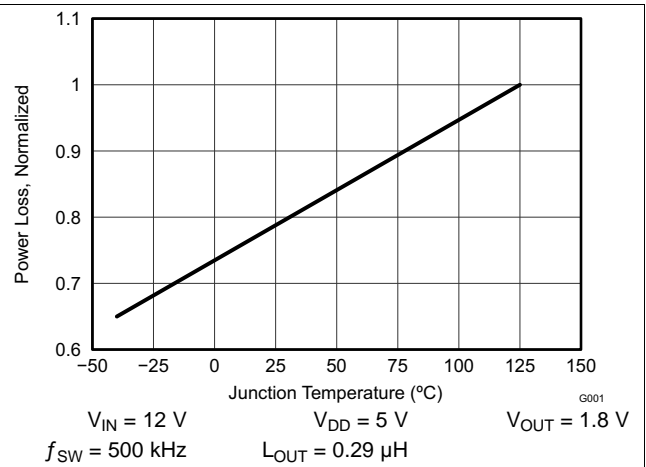

Figure 2. Power Loss vs Temperature

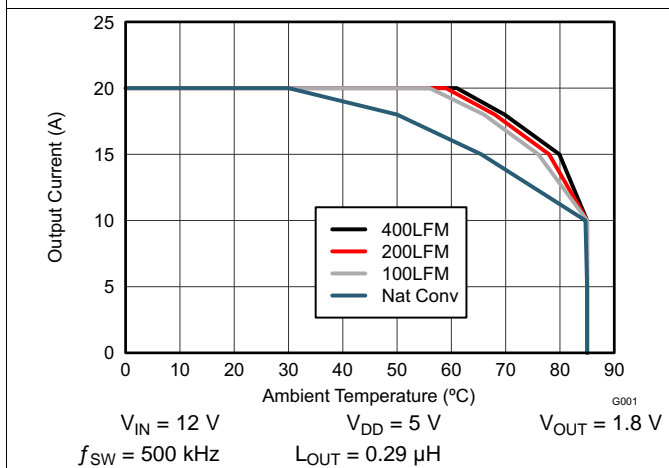

Figure 3. Safe Operating Area (SOA) – PCB Horizontal Mount

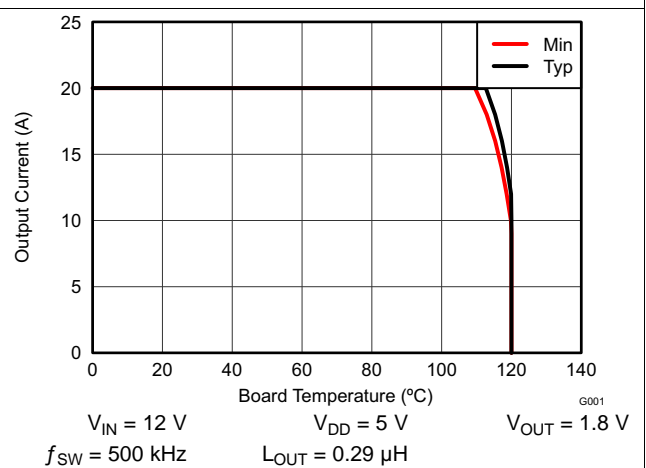

Figure 4. Typical SOA

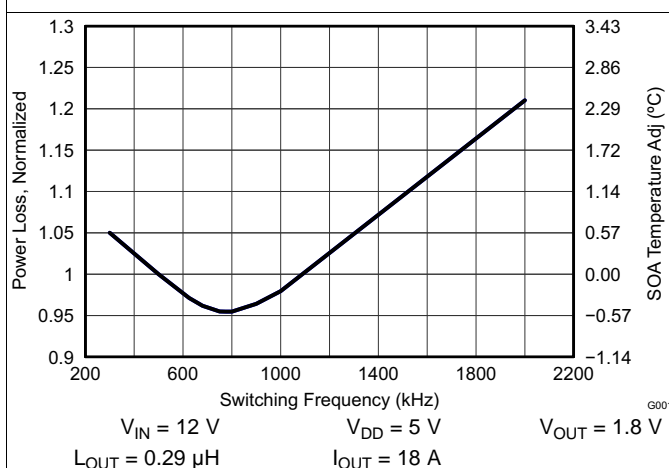

Figure 5. Normalized Power Loss vs Frequency

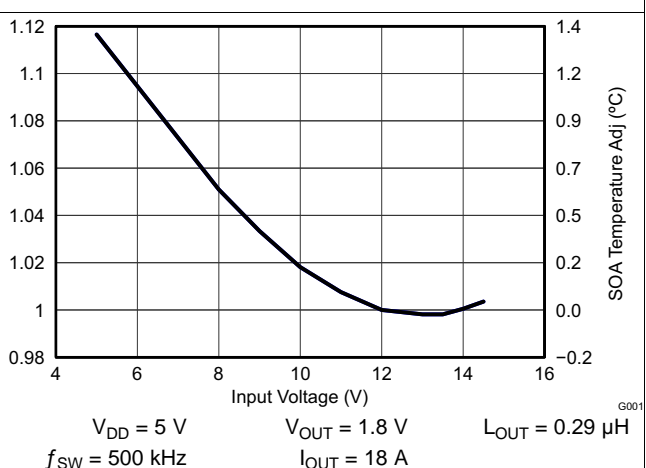
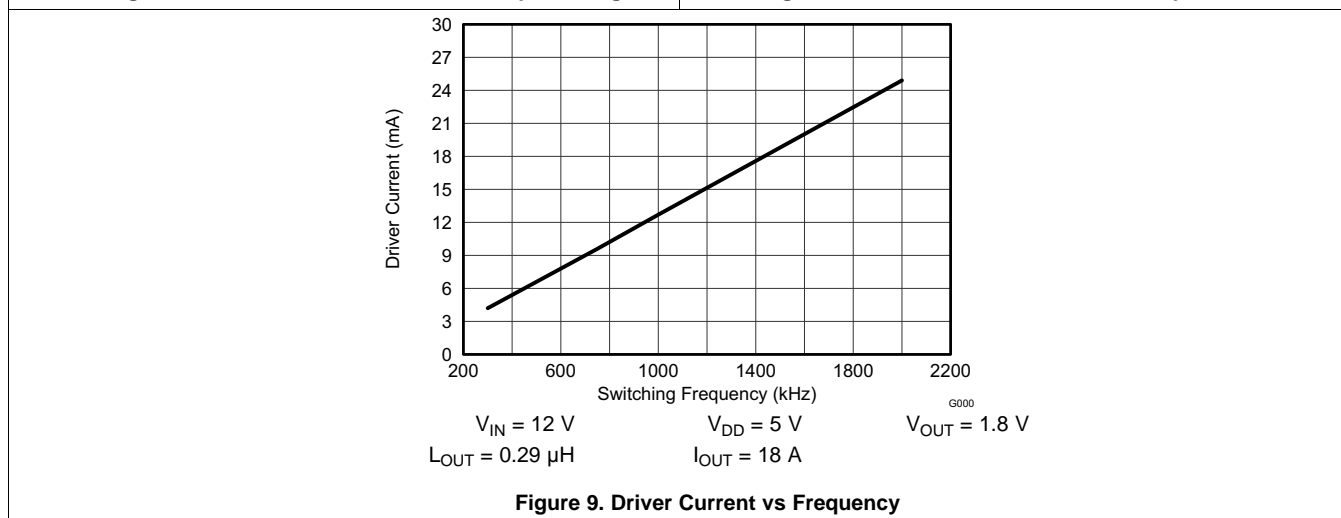
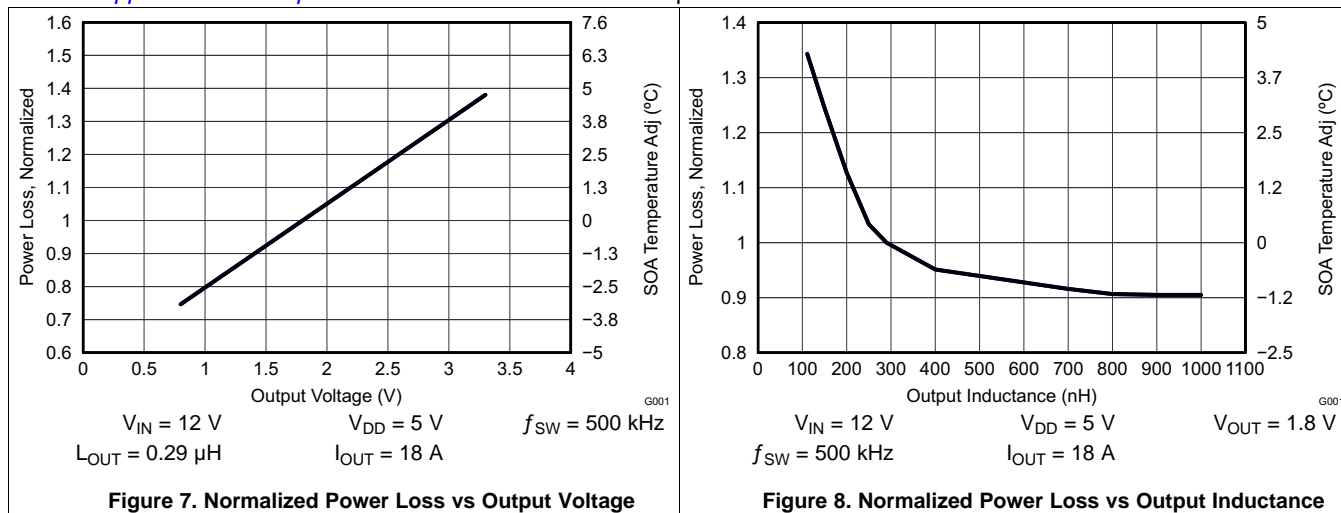

Figure 6. Normalized Power Loss vs Input Voltage

### Typical Characteristics (continued)

$T_J = 125^\circ\text{C}$ , unless stated otherwise. The Typical CSD95379Q3M system characteristic curves are based on measurements made on a PCB design with dimensions of 4 in (W)  $\times$  3.5 in (L)  $\times$  0.062 in (T) and 6 copper layers of 1-oz copper thickness. See the [Application and Implementation](#) section for detailed explanation.



## 7 Detailed Description

### 7.1 Functional Block Diagram

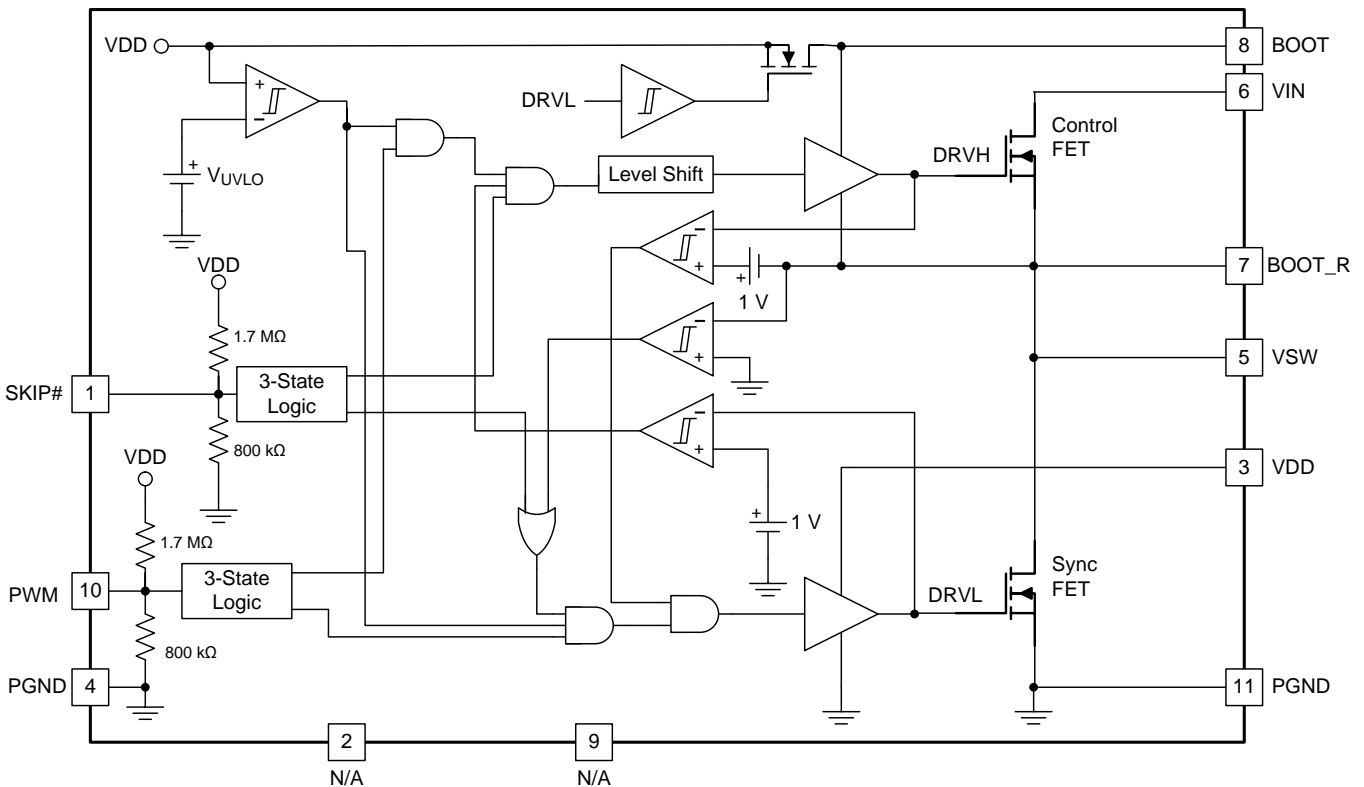

### 7.2 Feature Description

#### 7.2.1 Functional Description

##### 7.2.1.1 Powering CSD95379Q3M and Gate Drivers

An external  $V_{DD}$  voltage is required to supply the integrated gate driver IC and provide the necessary gate drive power for the MOSFETS. TI recommends a 1- $\mu$ F, 10-V X5R or higher ceramic capacitor to bypass  $V_{DD}$  pin to  $P_{GND}$ . A bootstrap circuit to provide gate drive power for the control FET is also included. The bootstrap supply to drive the control FET is generated by connecting a 100-nF, 16-V X5R ceramic capacitor between BOOT and BOOT\_R pins. An optional  $R_{BOOT}$  resistor can be used to slow down the turnon speed of the control FET and reduce voltage spikes on the  $V_{SW}$  node. A typical 1- $\Omega$  to 4.7- $\Omega$  value is a compromise between switching loss and  $V_{SW}$  spike amplitude.

## Feature Description (continued)

### 7.2.2 Undervoltage Lockout (UVLO) Protection

The UVLO comparator evaluates the VDD voltage level. As  $V_{VDD}$  rises, both the control FET and sync FET gates hold actively low at all times until  $V_{VDD}$  reaches the higher UVLO threshold ( $V_{UVLO\_H}$ ). Then, the driver becomes operational and responds to PWM and SKIP# commands. If VDD falls below the lower UVLO threshold ( $V_{UVLO\_L} = V_{UVLO\_H} - \text{hysteresis}$ ), the device disables the driver and drives the outputs of the control FET and sync FET gates actively low. Figure 10 shows this function.

**CAUTION**  
Do not start the driver in the very low power mode (SKIP# = Tri-state).

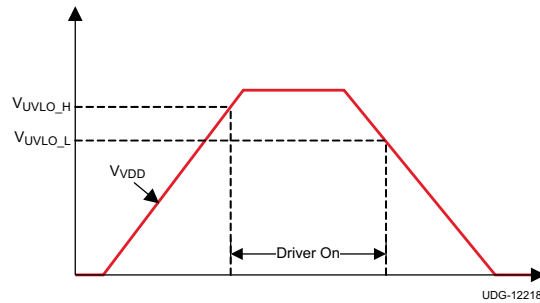

Figure 10. UVLO Operation

### 7.2.3 PWM Pin

The PWM pin incorporates an input tri-state function. The device forces the gate driver outputs to low when PWM is driven into the tri-state window and the driver enters a low-power state with zero exit latency. The pin incorporates a weak pullup to maintain the voltage within the tri-state window during low-power modes. Operation into and out of tri-state mode follows the timing diagram outlined in Figure 11.

When VDD reaches the UVLO\_H level, a tri-state voltage range (window) is set for the PWM input voltage. The window is defined as the PWM voltage range between PWM logic high ( $V_{IH}$ ) and logic low ( $V_{IL}$ ) thresholds. The device sets high-level input voltage and low-level input voltage threshold levels to accommodate both 3.3-V (typical) and 5-V (typical) PWM drive signals.

When the PWM exits tri-state, the driver enters CCM for a period of 4  $\mu\text{s}$ , regardless of the state of the SKIP# pin. Normal operation requires this time period in order for the auto-zero comparator to resume.

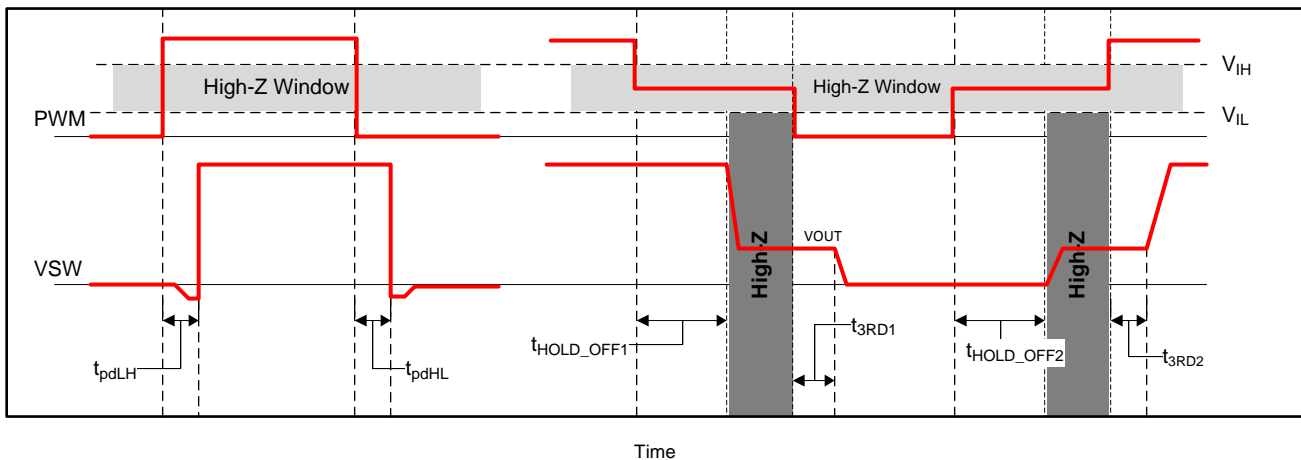

Figure 11. PWM Tri-State Timing Diagram

## Feature Description (continued)

### 7.2.4 SKIP# Pin

The SKIP# pin incorporates the input tri-state buffer as PWM. The function is somewhat different. When SKIP# is low, the zero crossing (ZX) detection comparator is enabled, and DCM mode operation occurs if the load current is less than the critical current. When SKIP# is high, the ZX comparator disables, and the converter enters FCCM mode. When both SKIP# and PWM are tri-stated, normal operation forces the gate driver outputs low and the driver enters a low-power state. In the low-power state, the UVLO comparator remains off to reduce quiescent current. When SKIP# is pulled low, the driver wakes up and is able to accept PWM pulses in less than 50  $\mu$ s.

Table 1 shows the logic functions of UVLO, PWM, SKIP#, the control FET gate, and the sync FET gate.

**Table 1. Logic Functions of the Driver IC**

UVLO	PWM	SKIP#	Sync FET Gate	Control FET Gate	MODE
Active	—	—	Low	Low	Disabled
Inactive	Low	Low	High <sup>(1)</sup>	Low	DCM <sup>(1)</sup>
Inactive	Low	High	High	Low	FCCM
Inactive	High	H or L	Low	High	—
Inactive	Tri-state	H or L	Low	Low	LQ
Inactive	—	Tri-state	Low	Low	ULQ

(1) Until zero crossing protection occurs.

### 7.2.5 Zero Crossing (ZX) Operation

The zero crossing comparator is adaptive for improved accuracy. As the output current decreases from a heavy load condition, the inductor current also reduces and eventually arrives at a valley, where it touches zero current, which is the boundary between continuous conduction and discontinuous conduction modes. The SW pin detects the zero-current condition. When this zero inductor current condition occurs, the ZX comparator turns off the rectifying MOSFET.

## 8 Application and Implementation

### NOTE

Information in the following applications sections is not part of the TI component specification, and TI does not warrant its accuracy or completeness. TI's customers are responsible for determining suitability of components for their purposes. Customers should validate and test their design implementation to confirm system functionality.

### 8.1 Application Information

The power stage CSD95379Q3M is a highly optimized design for synchronous buck applications using NexFET devices with a 5-V gate drive. The control FET and sync FET silicon are parametrically tuned to yield the lowest power loss and highest system efficiency. As a result, a rating method is used that is tailored towards a more systems-centric environment. The high-performance gate driver IC integrated in the package helps minimize the parasitics and results in extremely fast switching of the power MOSFETs. System-level performance curves such as power loss, Safe Operating Area (SOA), and normalized graphs allow engineers to predict the product performance in the actual application.

#### 8.1.1 Power Loss Curves

MOSFET-centric parameters such as  $R_{DS(ON)}$  and  $Q_{gd}$  are primarily needed by engineers to estimate the loss generated by the devices. In an effort to simplify the design process for engineers, TI has provided measured power loss performance curves. Figure 1 plots the power loss of the CSD95379Q3M as a function of load current. This curve is measured by configuring and running the CSD95379Q3M as it would be in the final application (see Figure 12). The measured power loss is the CSD95379Q3M device power loss which consists of both input conversion loss and gate drive loss. Equation 1 is used to generate the power loss curve.

$$\text{Power loss} = (V_{IN} \times I_{IN}) + (V_{DD} \times I_{DD}) - (V_{SW\_AVG} \times I_{OUT}) \quad (1)$$

The power loss curve in Figure 1 is measured at the maximum recommended junction temperature of  $T_J = 125^\circ\text{C}$  under isothermal test conditions.

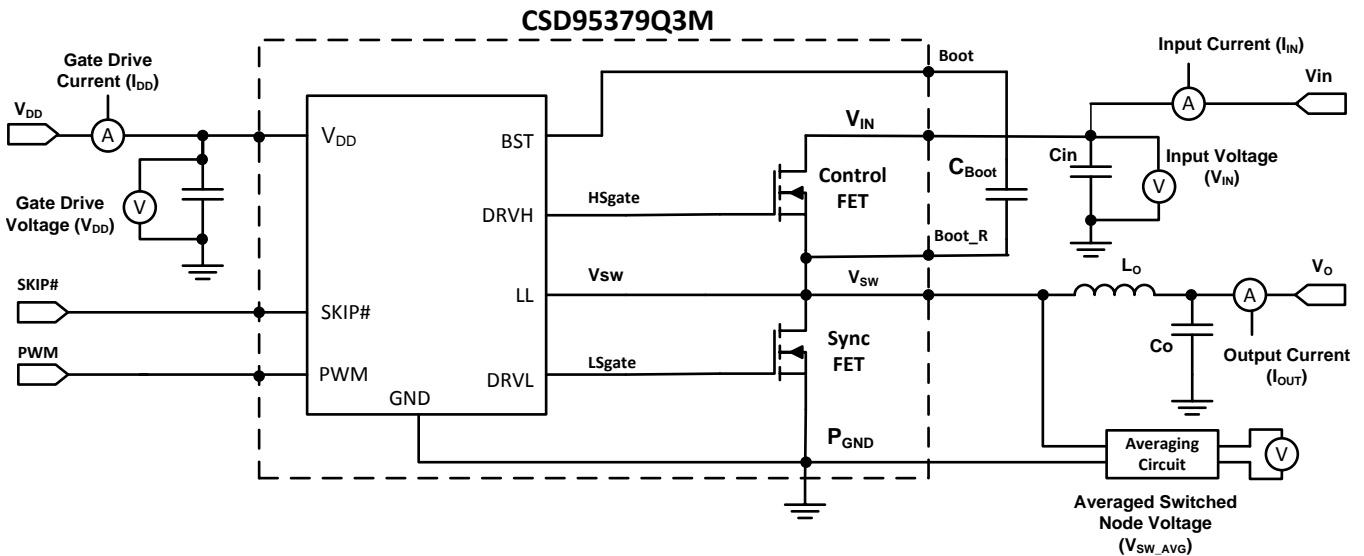

Figure 12. Power Loss Test Circuit

#### 8.1.2 Safe Operating Area (SOA) Curves

The SOA curves in the CSD95379Q3M data sheet give engineers guidance on the temperature boundaries within an operating system by incorporating the thermal resistance and system power loss. Figure 3 and Figure 4 outline the temperature and airflow conditions required for a given load current. The area under the curve dictates the safe operating area. All the curves are based on measurements made on a PCB design with dimensions of 4 in (W) × 3.5 in (L) × 0.062 in (T) and 6 copper layers of 1-oz copper thickness.

## Application Information (continued)

### 8.1.3 Normalized Curves

The normalized curves in the CSD95379Q3M data sheet give engineers guidance on the power loss and SOA adjustments based on their application specific needs. These curves show how the power loss and SOA boundaries adjust for a given set of systems conditions. The primary y-axis is the normalized change in power loss and the secondary y-axis is the change in system temperature required in order to comply with the SOA curve. The change in power loss is a multiplier for the power loss curve and the change in temperature is subtracted from the SOA curve.

### 8.1.4 Calculating Power Loss and SOA

The user can estimate product loss and SOA boundaries by arithmetic means (see the [Design Example](#)). Though the power loss and SOA curves in this data sheet are taken for a specific set of test conditions, the following procedure outlines the steps engineers should take to predict product performance for any set of system conditions.

#### 8.1.4.1 Design Example

Operating conditions: output current ( $I_{OUT}$ ) = 10 A, input voltage ( $V_{IN}$ ) = 8 V, output voltage ( $V_{OUT}$ ) = 1.5 V, switching frequency ( $f_{SW}$ ) = 1500 kHz, output inductor ( $L_{OUT}$ ) = 0.2  $\mu$ H

#### 8.1.4.2 Calculating Power Loss

- Typical power loss at 10 A = 1.8 W ([Figure 1](#))
- Normalized power loss for switching frequency  $\approx$  1.09 ([Figure 5](#))
- Normalized power loss for input voltage  $\approx$  1.05 ([Figure 6](#))
- Normalized power loss for output voltage  $\approx$  0.92 ([Figure 7](#))
- Normalized power loss for output inductor  $\approx$  1.1 ([Figure 8](#))
- **Final calculated power loss = 1.8 W  $\times$  1.09  $\times$  1.05  $\times$  0.92  $\times$  1.1  $\approx$  2.1 W**

#### 8.1.4.3 Calculating SOA Adjustments

- SOA adjustment for switching frequency  $\approx$  1.1°C ([Figure 5](#))
- SOA adjustment for input voltage  $\approx$  0.6°C ([Figure 6](#))
- SOA adjustment for output voltage  $\approx$  -0.9°C ([Figure 7](#))
- SOA adjustment for output inductor  $\approx$  1.3°C ([Figure 8](#))
- **Final calculated SOA adjustment = 1.1 + 0.6 + (-0.9) + 1.3  $\approx$  2.1°C**

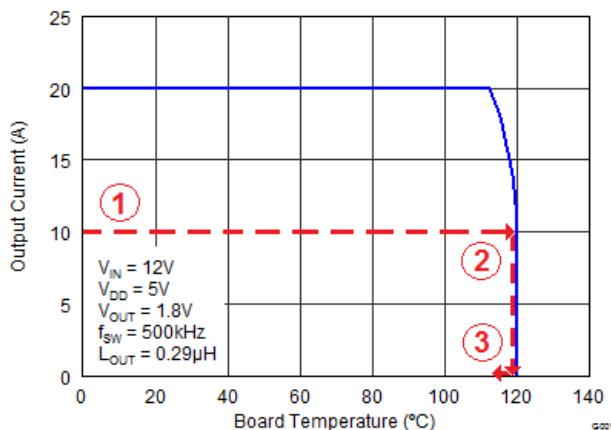

**Figure 13. Power Stage CSD95379Q3M SOA**

In the [Design Example](#), the estimated power loss of the CSD95379Q3M would increase to 2.1 W. In addition, the maximum allowable board or ambient temperature, or both, would have to decrease by 2.1°C. [Figure 13](#) graphically shows how the SOA curve would be adjusted accordingly.

**Application Information (continued)**

1. Start by drawing a horizontal line from the application current to the SOA curve.
2. Draw a vertical line from the SOA curve intercept down to the board or ambient temperature.
3. Adjust the SOA board/ambient temperature by subtracting the temperature adjustment value.

In the design example, the SOA temperature adjustment yields a reduction in allowable board or ambient temperature of 2.1°C. In the event the adjustment value is a negative number, subtracting the negative number would yield an increase in allowable board or ambient temperature.

## 9 Layout

### 9.1 Layout Guidelines

There are two key system-level parameters that can be addressed with a proper PCB design: electrical and thermal performance. Properly optimizing the PCB layout yields maximum performance in both areas. A brief description on how to address each parameter follows.

#### 9.1.1 Electrical Performance

The CSD95379Q3M has the ability to switch at voltage rates greater than 10 kV/μs. Take special care with the PCB layout design and placement of the input capacitors, inductor, and output capacitors.

- The placement of the input capacitors relative to  $V_{IN}$  and  $P_{GND}$  pins of CSD95379Q3M device should have the highest priority during the component placement routine. It is critical to minimize these node lengths. As such, ceramic input capacitors need to be placed as close as possible to the  $V_{IN}$  and  $P_{GND}$  pins (see [Figure 14](#)). The example in [Figure 14](#) uses 1 × 1-nF 0402 25-V and 3 × 10-μF 1206 25-V ceramic capacitors (TDK part number C3216X5R1C106KT or equivalent). Notice there are ceramic capacitors on both sides of the board with an appropriate amount of vias interconnecting both layers. In terms of priority of placement next to the power stage C8, C9, C10 and C11 should follow in order.
- The bootstrap capacitor C7 0.1-μF 0603 16-V ceramic capacitor should be closely connected between BOOT and BOOT\_R pins.
- The switching node of the output inductor should be placed relatively close to the power stage CSD95379Q3M  $V_{SW}$  pins. Minimizing the  $V_{SW}$  node length between these two components will reduce the PCB conduction losses and actually reduce the switching noise level. <sup>(1)</sup>

#### 9.1.2 Thermal Performance

The CSD95379Q3M has the ability to use the GND planes as the primary thermal path. As such, the use of thermal vias is an effective way to pull away heat from the device and into the system board. Concerns of solder voids and manufacturability problems can be addressed by the use of three basic tactics to minimize the amount of solder attach that wicks down the via barrel:

- Intentionally space out the vias from each other to avoid a cluster of holes in a given area.
- Use the smallest drill size allowed in your design. The example in [Figure 14](#) uses vias with a 10-mil drill hole and a 16-mil capture pad.
- Tent the opposite side of the via with solder-mask.

The number and drill size of the thermal vias should align with the end user's PCB design rules and manufacturing capabilities.

### 9.2 Layout Example

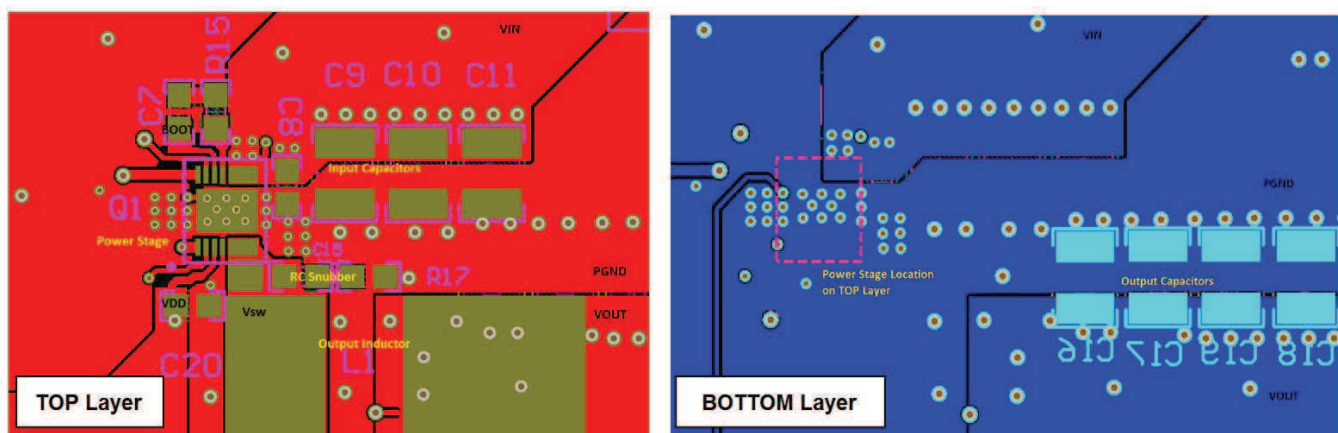

**Figure 14. Recommended PCB Layout (Top Down View)**

(1) Keong W. Kam, David Pommerenke, "EMI Analysis Methods for Synchronous Buck Converter EMI Root Cause Analysis", University of Missouri – Rolla

## 10 Device and Documentation Support

### 10.1 Receiving Notification of Documentation Updates

To receive notification of documentation updates, navigate to the device product folder on ti.com. In the upper right corner, click on *Alert me* to register and receive a weekly digest of any product information that has changed. For change details, review the revision history included in any revised document.

### 10.2 Community Resources

The following links connect to TI community resources. Linked contents are provided "AS IS" by the respective contributors. They do not constitute TI specifications and do not necessarily reflect TI's views; see TI's [Terms of Use](#).

**TI E2E™ Online Community** *TI's Engineer-to-Engineer (E2E) Community*. Created to foster collaboration among engineers. At e2e.ti.com, you can ask questions, share knowledge, explore ideas and help solve problems with fellow engineers.

**Design Support** *TI's Design Support* Quickly find helpful E2E forums along with design support tools and contact information for technical support.

### 10.3 Trademarks

NexFET, E2E are trademarks of Texas Instruments.  
Windows is a registered trademark of Microsoft Corporation.  
All other trademarks are the property of their respective owners.

### 10.4 Electrostatic Discharge Caution



These devices have limited built-in ESD protection. The leads should be shorted together or the device placed in conductive foam during storage or handling to prevent electrostatic damage to the MOS gates.

### 10.5 Glossary

**SLYZ022** — *TI Glossary*.

This glossary lists and explains terms, acronyms, and definitions.

## 11 Mechanical, Packaging, and Orderable Information

The following pages include mechanical, packaging, and orderable information. This information is the most current data available for the designated devices. This data is subject to change without notice and revision of this document. For browser-based versions of this data sheet, refer to the left-hand navigation.

### 11.1 Mechanical Drawing

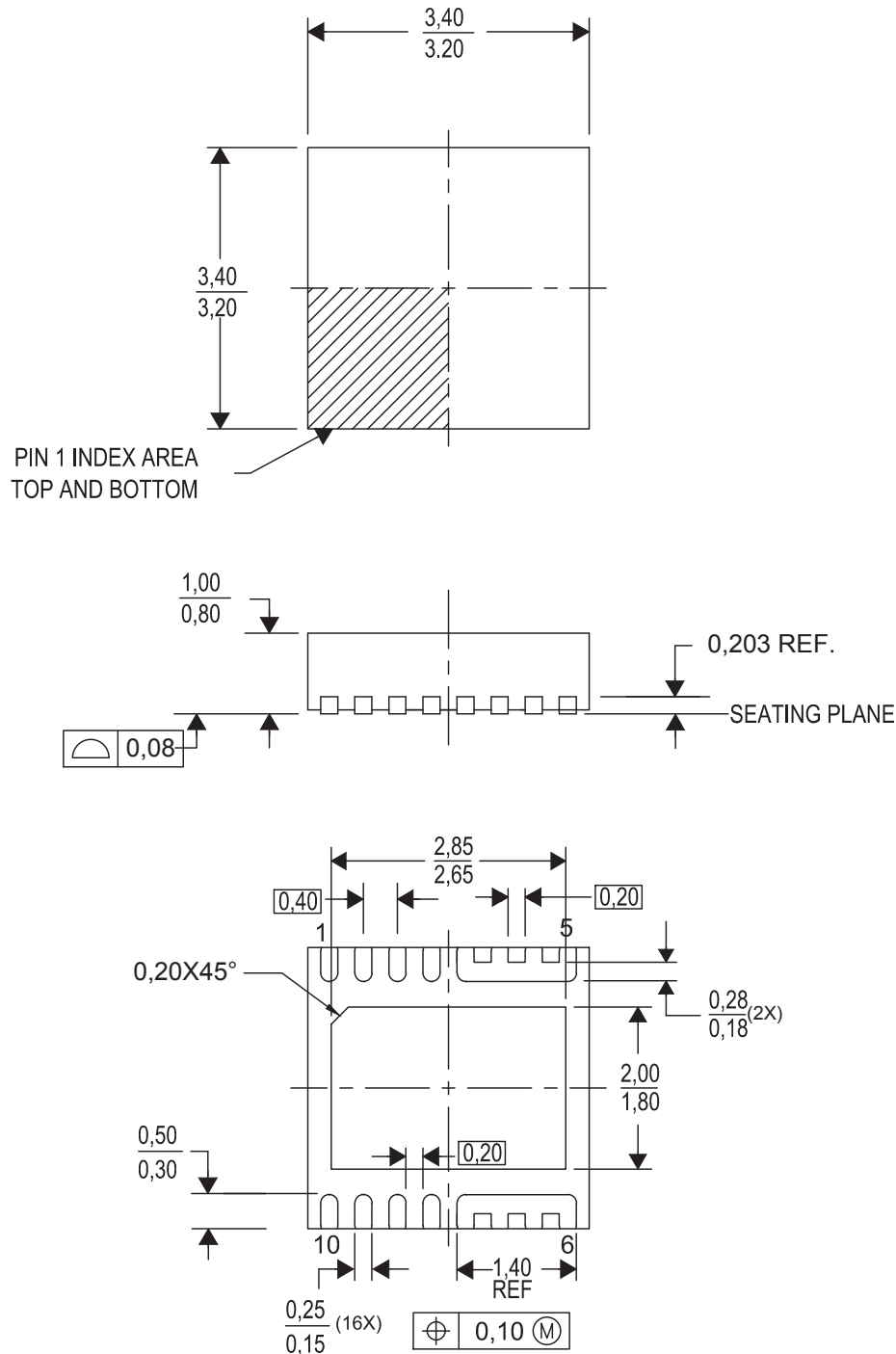

### 11.2 Recommended PCB Land Pattern

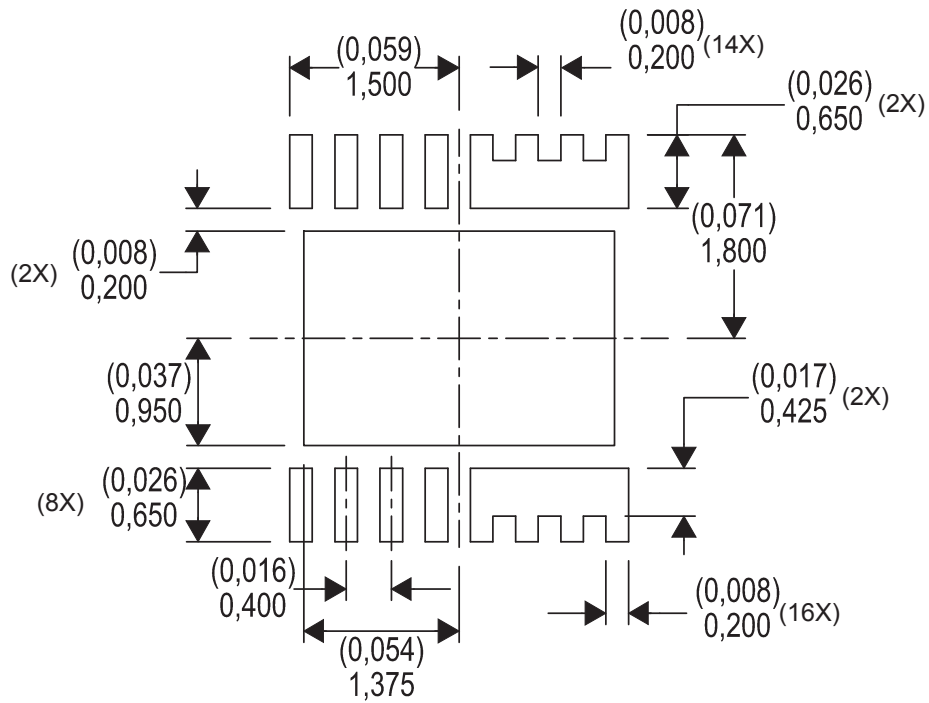

1. Dimensions are in mm (in).

### 11.3 Recommended Stencil Opening

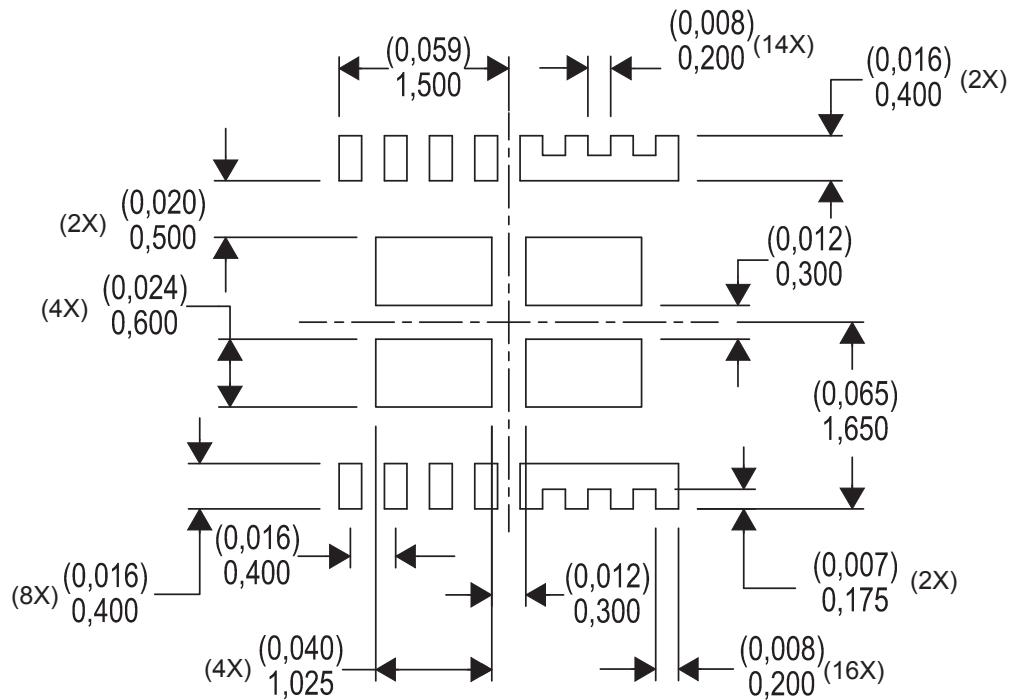

1. Dimensions are in mm (in).

**PACKAGING INFORMATION**

Orderable Device	Status (1)	Package Type	Package Drawing	Pins	Package Qty	Eco Plan (2)	Lead/Ball Finish (6)	MSL Peak Temp (3)	Op Temp (°C)	Device Marking (4/5)	Samples
CSD95379Q3M	ACTIVE	VSON-CLIP	DNS	10	2500	Pb-Free (RoHS Exempt)	CU NIPDAU	Level-2-260C-1 YEAR	-40 to 150	95379M	<a href="#">Samples</a>
CSD95379Q3MT	ACTIVE	VSON-CLIP	DNS	10	250	Pb-Free (RoHS Exempt)	CU NIPDAU	Level-2-260C-1 YEAR	-40 to 150	95379M	<a href="#">Samples</a>

(1) The marketing status values are defined as follows:

**ACTIVE:** Product device recommended for new designs.

**LIFEBUY:** TI has announced that the device will be discontinued, and a lifetime-buy period is in effect.

**NRND:** Not recommended for new designs. Device is in production to support existing customers, but TI does not recommend using this part in a new design.

**PREVIEW:** Device has been announced but is not in production. Samples may or may not be available.

**OBSOLETE:** TI has discontinued the production of the device.

(2) Eco Plan - The planned eco-friendly classification: Pb-Free (RoHS), Pb-Free (RoHS Exempt), or Green (RoHS & no Sb/Br) - please check <http://www.ti.com/productcontent> for the latest availability information and additional product content details.

**TBD:** The Pb-Free/Green conversion plan has not been defined.

**Pb-Free (RoHS):** TI's terms "Lead-Free" or "Pb-Free" mean semiconductor products that are compatible with the current RoHS requirements for all 6 substances, including the requirement that lead not exceed 0.1% by weight in homogeneous materials. Where designed to be soldered at high temperatures, TI Pb-Free products are suitable for use in specified lead-free processes.

**Pb-Free (RoHS Exempt):** This component has a RoHS exemption for either 1) lead-based flip-chip solder bumps used between the die and package, or 2) lead-based die adhesive used between the die and leadframe. The component is otherwise considered Pb-Free (RoHS compatible) as defined above.

**Green (RoHS & no Sb/Br):** TI defines "Green" to mean Pb-Free (RoHS compatible), and free of Bromine (Br) and Antimony (Sb) based flame retardants (Br or Sb do not exceed 0.1% by weight in homogeneous material)

(3) MSL, Peak Temp. - The Moisture Sensitivity Level rating according to the JEDEC industry standard classifications, and peak solder temperature.

(4) There may be additional marking, which relates to the logo, the lot trace code information, or the environmental category on the device.

(5) Multiple Device Markings will be inside parentheses. Only one Device Marking contained in parentheses and separated by a "~" will appear on a device. If a line is indented then it is a continuation of the previous line and the two combined represent the entire Device Marking for that device.

(6) Lead/Ball Finish - Orderable Devices may have multiple material finish options. Finish options are separated by a vertical ruled line. Lead/Ball Finish values may wrap to two lines if the finish value exceeds the maximum column width.

**Important Information and Disclaimer:** The information provided on this page represents TI's knowledge and belief as of the date that it is provided. TI bases its knowledge and belief on information provided by third parties, and makes no representation or warranty as to the accuracy of such information. Efforts are underway to better integrate information from third parties. TI has taken and continues to take reasonable steps to provide representative and accurate information but may not have conducted destructive testing or chemical analysis on incoming materials and chemicals. TI and TI suppliers consider certain information to be proprietary, and thus CAS numbers and other limited information may not be available for release.

In no event shall TI's liability arising out of such information exceed the total purchase price of the TI part(s) at issue in this document sold by TI to Customer on an annual basis.

**TAPE AND REEL INFORMATION**

**QUADRANT ASSIGNMENTS FOR PIN 1 ORIENTATION IN TAPE**

\*All dimensions are nominal

Device	Package Type	Package Drawing	Pins	SPQ	Reel Diameter (mm)	Reel Width W1 (mm)	A0 (mm)	B0 (mm)	K0 (mm)	P1 (mm)	W (mm)	Pin1 Quadrant
CSD95379Q3M	VSON-CLIP	DNS	10	2500	330.0	12.4	3.6	3.6	1.2	8.0	12.0	Q2
CSD95379Q3MT	VSON-CLIP	DNS	10	250	180.0	12.4	3.6	3.6	1.2	8.0	12.0	Q2

**TAPE AND REEL BOX DIMENSIONS**

\*All dimensions are nominal

Device	Package Type	Package Drawing	Pins	SPQ	Length (mm)	Width (mm)	Height (mm)
CSD95379Q3M	VSON-CLIP	DNS	10	2500	367.0	367.0	35.0
CSD95379Q3MT	VSON-CLIP	DNS	10	250	210.0	185.0	35.0

## IMPORTANT NOTICE AND DISCLAIMER

TI PROVIDES TECHNICAL AND RELIABILITY DATA (INCLUDING DATASHEETS), DESIGN RESOURCES (INCLUDING REFERENCE DESIGNS), APPLICATION OR OTHER DESIGN ADVICE, WEB TOOLS, SAFETY INFORMATION, AND OTHER RESOURCES "AS IS" AND WITH ALL FAULTS, AND DISCLAIMS ALL WARRANTIES, EXPRESS AND IMPLIED, INCLUDING WITHOUT LIMITATION ANY IMPLIED WARRANTIES OF MERCHANTABILITY, FITNESS FOR A PARTICULAR PURPOSE OR NON-INFRINGEMENT OF THIRD PARTY INTELLECTUAL PROPERTY RIGHTS.

These resources are intended for skilled developers designing with TI products. You are solely responsible for (1) selecting the appropriate TI products for your application, (2) designing, validating and testing your application, and (3) ensuring your application meets applicable standards, and any other safety, security, or other requirements. These resources are subject to change without notice. TI grants you permission to use these resources only for development of an application that uses the TI products described in the resource. Other reproduction and display of these resources is prohibited. No license is granted to any other TI intellectual property right or to any third party intellectual property right. TI disclaims responsibility for, and you will fully indemnify TI and its representatives against, any claims, damages, costs, losses, and liabilities arising out of your use of these resources.

TI's products are provided subject to TI's Terms of Sale ([www.ti.com/legal/termsofsale.html](http://www.ti.com/legal/termsofsale.html)) or other applicable terms available either on [ti.com](http://ti.com) or provided in conjunction with such TI products. TI's provision of these resources does not expand or otherwise alter TI's applicable warranties or warranty disclaimers for TI products.

Mailing Address: Texas Instruments, Post Office Box 655303, Dallas, Texas 75265  
Copyright © 2018, Texas Instruments Incorporated

## Looking for pricing, stock, or lifecycle information?

Click below to explore more details on WIN SOURCE:

 [View CSD95379Q3MT](#) on WIN SOURCE

 [Texas Instruments](#) Information

## Optimize Your Supply Chain with WIN SOURCE Solutions

-  Global Sourcing Solution
-  Obsolete Management
-  Cost Control Management
-  Shortage Management
-  Alternative Solution
-  Excess Inventory Management